

ASSEMBLY NUMBER	PT NUMBER	DIMENSIONS															
		C	D	E	K	L	M	N	R	S	T	V		Z	KK	SS	U
		+0.010 -0.025	+0.010 -0.025	+0.010 -0.020	+0.020 -0.010	+0.040 -0.030	+0.010 -0.000	+0.001 -0.005	(TP)	DIA	±.005	THREAD	SIZE CLASS 2A	PITCH DIA	+0.040 -0.050	DIA +.000 -.031	DIA +.000 -.016
71-146006-	00A-6-	.337	.025	.085	.493	1.513	.431	.348	.469	.688	.120	.3750-32 NEF	.3547-.3503	.394	.453	.439	.153
71-146008-	-8-							.473	.594	.812		.5000-28 UNEF	.4768-.4720		.578	.563	
71-146010-	-10-							.590	.719	.938		.6250-24 NEF	.5979-.5927		.703	.680	
71-146012-	-12-							.750	.812	1.031		.7500-20 UNEF	.7175-.7118		.828	.859	
71-146014-	-14-							.875	.906	1.125		.8750-20 UNEF	.8425-.8368		.968	.984	
71-146016-	-16-							1.000	.969	1.219		1.0000-20 UNEF	.9675-.9616		1.078	1.108	
71-146018-	-18-							1.125	1.062	1.312		1.1875-18 NEF	1.1514-1.1450		1.203	1.233	
71-146020-	-20-	.399	.087	.147	.650	1.635	.556	1.250	1.156	1.438		1.1875-18 NEF	1.1514-1.1450	.455	1.328	1.358	.215
71-146022-	-22-	.399	.087	.147	.650	1.635	.556	1.375	1.250	1.562		1.4375-18 NEF	1.4014-1.3949	.455	1.453	1.483	
71-146024-	-24-	.399	.087	.147	.683	1.697	.589	1.500	1.375	1.688	.147	1.4375-18 NEF	1.4014-1.3949	.422	1.578	1.614	
71-146025/50		NOT AVAILABLE															

REL	32508-155	WAS	DATE	D'MAN	AP
1	34105-15	N +.000 - .005 DIA	5-28-58	MOORE	XMP
2	33524-602	ADD & REL SIZE 24 & DATA	7-28-58	D.WAY	RP
3	35525-224	REV KK DIA, COL, SSDIA COL; STANDARDIZED, T DIA +.004 - .002	10-29-58	Markowski	Hand
4	36162-8	TEST 9-3353-2 (PRO SPEC)	1-28-60	Markowski	Hand
A1	45525-946	(MFG); ADD. TC DATA BLOCK, ADD. NOTE 13; DISCARDED DRAWING 71-146008-82, -010-80, 014-81, 016-80	6-27-66	MATTICE	Hand
A2	51430-1	REM NOTE 11	4-20-70	Camel	Hand
B	72028-49	(CL II) ADAPTER WAS 10-117911-XX3, REV. "L" COL.	2-4-81	LEWIS	Hand
C	A0738	(CL II) ADDED 10-252806/824-( )	12-20-06	VJ	

ACCESSORIES (NOT PART OF STANDARD ASSEMBLY)	
SEE DRAWING 10-150000	
CONTACT DATA (WHERE APPLICABLE)	
THERMOCOUPLE	
MATERIAL	IDENTIFICATION
CHROMEL	WHITE
ALUMEL	GREEN
IRON	BLACK
CONSTANTAN	YELLOW
INSERT ARRANGEMENTS CONTAINING THERMOCOUPLE CONTACTS MUST HAVE SUCH CONTACTS ASSEMBLED INTO THE INSERT IN PROPER LOCATIONS AS SPECIFIED BY APPLICABLE DRAWINGS L-15206-( ) THRU L-15250-( )	

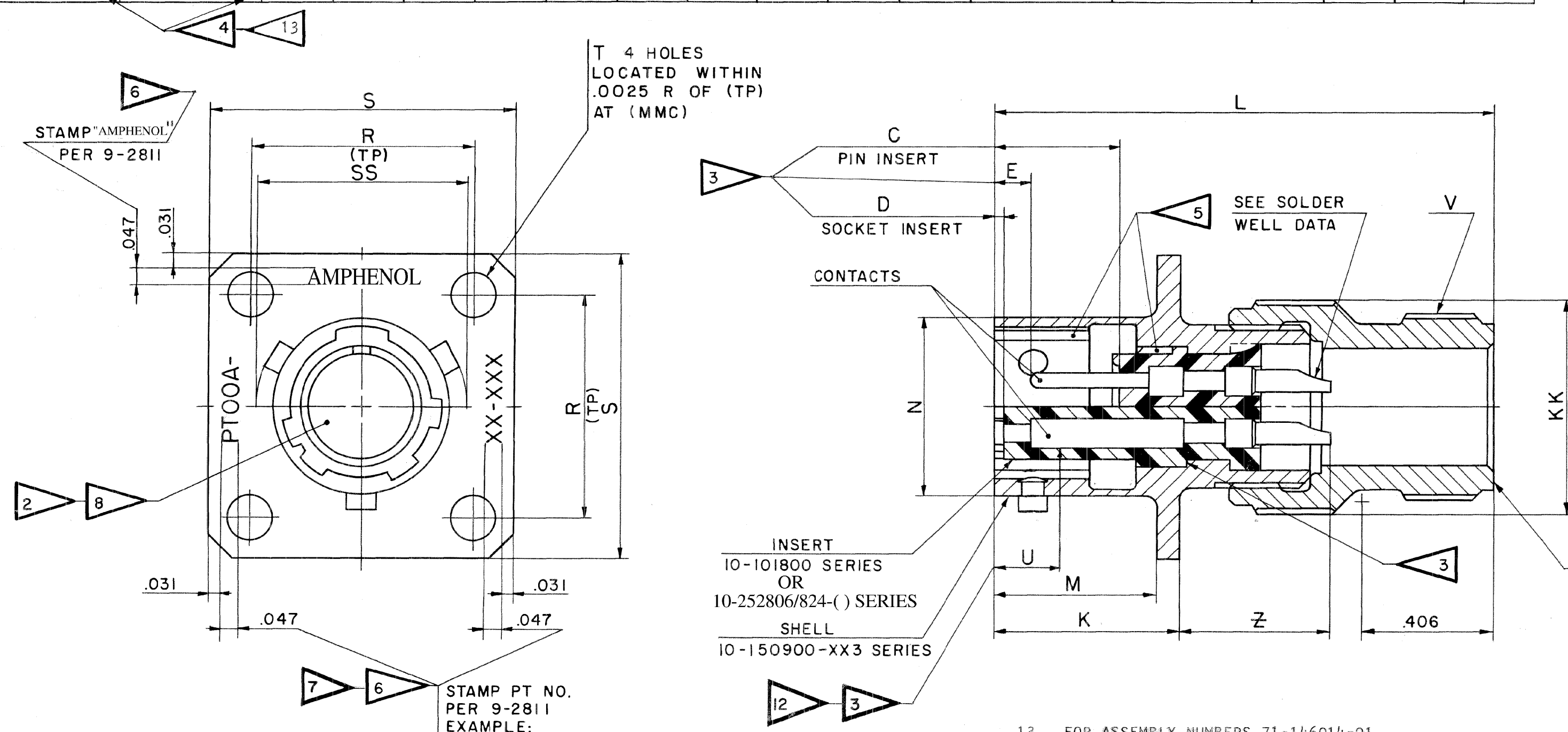

6. STAMPING MAY BE ON EITHER SIDE OF FLANGE (ONE SIDE ONLY).
5. VERTICAL CENTERLINES OF INSERT ARRANGEMENT & THE MAIN SHELL POLARIZING KEYWAY TO BE WITHIN .005 OF INDICATED ROTATION PER 9-2437-1.
4. TO COMPLETE ASSY NO. & PT NO., ADD APPLICABLE INSERT ARRANGEMENT SUFFIX TO BASE NUMBERS LISTED ABOVE PER 9-2437-1.
3. DIMENSIONS MUST BE MAINTAINED WHEN INSERTS ARE PRESSED FIRMLY AGAINST INDICATED SHOULDER.
2. FOR CONTACT ARRANGEMENTS, SEE DRAWINGS L-15206-( ) THRU L-15250-( ).
1. TOLERANCES ON TRUE POSITION (TP) DIMENSIONS APPLY AT MAXIMUM MATERIAL CONDITION (MMC).
- NOTES:
12. DISTANCE BETWEEN END OF SHELL AND THE POINT AT WHICH A GAGE PIN, HAVING THE SAME BASIC DIAMETER AS THE MATING CONTACT AND A SQUARE FACE, ENGAGES SOCKET CONTACT SPRING.
11. FOR COMPONENT PART NUMBERS OF DESIRED ARRANGEMENT, SEE APPLICABLE PARTS LIST.
9. SEE DRAWING 71-145606/50 AND OTHERS FOR REQUIRED MATING PLUG ASSEMBLY.
8. INSERTS AND CONTACTS MUST NOT BE REMOVED.
7. SEE WORK ORDER FOR PERMISSIBLE ADDITIONAL OR ALTERNATE STAMPING.

13. FOR ASSEMBLY NUMBERS 71-146014-91, 71-146018-80 SEE INDIVIDUAL DRAWINGS.

USE OF THIS DOCUMENT IS UNLIMITED DOCUMENTS REFERENCED HEREON CONTAIN LIMITED RIGHTS DATA.

SOLDER WELL DATA			
CONTACT SIZE	20	16	
WELL DIA	.046 +.004 -.000	.078 +.004 -.002	
WELL DEPTH	.125 +.031 -.000	.188	

MATERIAL SPEC.	PROCESS SPEC. TEST 9-3980-2 ASSY 9-3443-1 9-2437-1 9-2811	SCINTILLA MAGNETO DIVISION BENDIX AVIATION CORPORATION SIDNEY, N. Y., U.S.A.		TOLERANCES UNLESS OTHERWISE SPECIFIED FRACTIONS ± 1/32 DECIMALS ± .010 ANGLES ± 2° CONCENTRICITY .018 PER INCH OF LENGTH SQUARENESS .010 PER INCH OF LENGTH MACHINED SURFACES MUST BE FLAT AND PARALLEL WITHIN THE TOLERANCE OF THE APPLICABLE DIMENSION AND SMOOTH WITHIN 200 MICRO-INCHES RMS.	
HEAT TREAT SPEC.	FINISH SPEC.	NAME CONNECTOR, ELECTRICAL RECEPTACLE, TYPE PTA ( ) FW, OLIVE DRAB		NEXT ASSEMBLY	
TOOL ACC.		D'MAN	CHECKER	MAT. P.	STOS
		RINES	KOVARICK		CH. D'MAN
					APPROVED
					SCALE
					NONE
		SUPERSEDES		AND IS NOT INTERCHANGEABLE	
		SUPERSEDED BY		71-146006 THRU 71-146050	
		REF.			

## X-ON Electronics

Largest Supplier of Electrical and Electronic Components

*Click to view similar products for [Circular MIL Spec Connector](#) category:*

*Click to view products by [Amphenol](#) manufacturer:*

Other Similar products are found below :

[0025-262-542](#) [0025-264-3014](#) [58-570121-04S](#) [0134-202-1200](#) [0134-207-1206](#) [0134-207-1800](#) [0134-207-2207](#) [0134-213-0806](#) [0134-213-1007](#) [0134-213-1009](#) [0134-213-1208](#) [0134-213-1800](#) [0134-213-2209](#) [0025-258-000](#) [015-9516-002](#) [60-042722-19P](#) [0114-201-1278](#) [602GB06EG24-61SN](#) [0134-201-1207](#) [0134-201-1806](#) [0134-201-2006](#) [0134-201-2007](#) [0134-201-2010](#) [0134-202-1400](#) [0134-207-0809](#) [0134-207-1208](#) [0134-207-2009](#) [0134-213-1006](#) [6104-207-2302](#) [6104-208-1902](#) [6131-202-19149P](#) [6131-204-21149P](#) [6131-207-13149P](#) [6131-208-13149P](#) [6131-209-17149P](#) [6131-210-11149P](#) [6131-211-19149P](#) [6131-216-19149P](#) [6131-220-25149P](#) [6131-259-11149P](#) [6131-259-21149P](#) [6131-259-23149P](#) [6131-263-19149P](#) [6131-265-17149P](#) [6131-265-19149P](#) [CS3102A-20-15P](#) [CS3102A-20-15S](#) [CS3102C18-4P-472](#) [CS3106A-20-29P](#) [CS3106A-20-74P](#)