

ASSEMBLY NUMBER	PT NUMBER	DIMENSIONS													
		C	D	E	L	N DIA	P	V		Z	KK	SS	K	S	U
		+0.10 -0.025	+0.010 -0.025	+0.010 -0.020	+0.040 -0.030	+0.001 -0.005		THREAD (PLATED)		±.030	DIA +0.000 -0.031	DIA +0.000 -0.016		±.016	MAX
						SIZE CLASS 2A	PITCH DIA								
71-146106-	01A-6-					.348	.188	.3750-32 NEF	.3547 - .3503	.887	.453	.439	.094	.688	.153
71-146108-	-8-					.473		.5000-28 UNEF	.4768 - .4720		.578	.563		.812	
71-146110-	-10-					.590		.6250-24 NEF	.5979 - .5927		.703	.680		.938	
71-146112-	-12-					.750		.7500-20 UNEF	.7175 - .7118		.828	.859		1.031	
71-146114-	-14-					.875		.8750-20 UNEF	.8425 - .8368		.968	.984		1.125	
71-146116-	-16-					1.000		1.0000-20 UNEF	.9675 - .9616		1.078	1.108		1.219	
71-146118-	-18-					1.125		1.1875-18 NEF	1.1514 - 1.1450		1.203	1.233		1.312	
71-146120-	-20-	.399	.087	.147	1.635	1.250	.344	1.1875-18 NEF	1.1514 - 1.1450	1.105	1.328	1.358	.115	1.438	.215
71-146122-	-22-	.399	.087	.147	1.635	1.375	.344	1.4375-18 NEF	1.4014 - 1.3949	1.105	1.453	1.483	.115	1.562	
71-146124-	-24-	.399	.087	.147	1.697	1.500	.344	1.4375-18 NEF	1.4014 - 1.3949	1.105	1.567	1.610	.115	1.688	
71-146125/50						NOT AVAILABLE									

REL	32508-147	WAS	DATE	D'MAN	APPD.
1	CNR	ADD: COL K & S; REV COL P; CHG PICT.	4-17-57	I.NILES	
2	34105-15	N +.000 -0.005 DIA	5-28-58	MOORE	
3	33624-602	ADD & REL SIZE 24 & DATA	7-28-58	D. WAY	
4	35525-238	L +.030 -0.020; REV KK DIA COL, SS DIA COL, S COL; STANDARDIZED	10-29-58	VIMISLIK	
5	36162-8	TEST 9-3353-2 (PRO SPEC)	1-28-60	MARKOSKI	
A1	45525-809	WAS .983 (COL SS, SIZE 14), 1.614 (COL SS, SIZE 24); (MFG)	5-5-66	BRADLEY	
A2	51430-1	REM NOTE 9	4-20-70	BRADLEY	
B	72028-49	(CL II) ADAPTER WAS 10-117911-XX3, REV. "L" COL.	2-4-81	LEWIS	
C	A0785	(CL II) ADDED 10-252806/824(-)	12-20-06	JONES	

ACCESSORIES  
(NOT PART OF STANDARD ASSY)  
SEE DRAWING  
10-150000

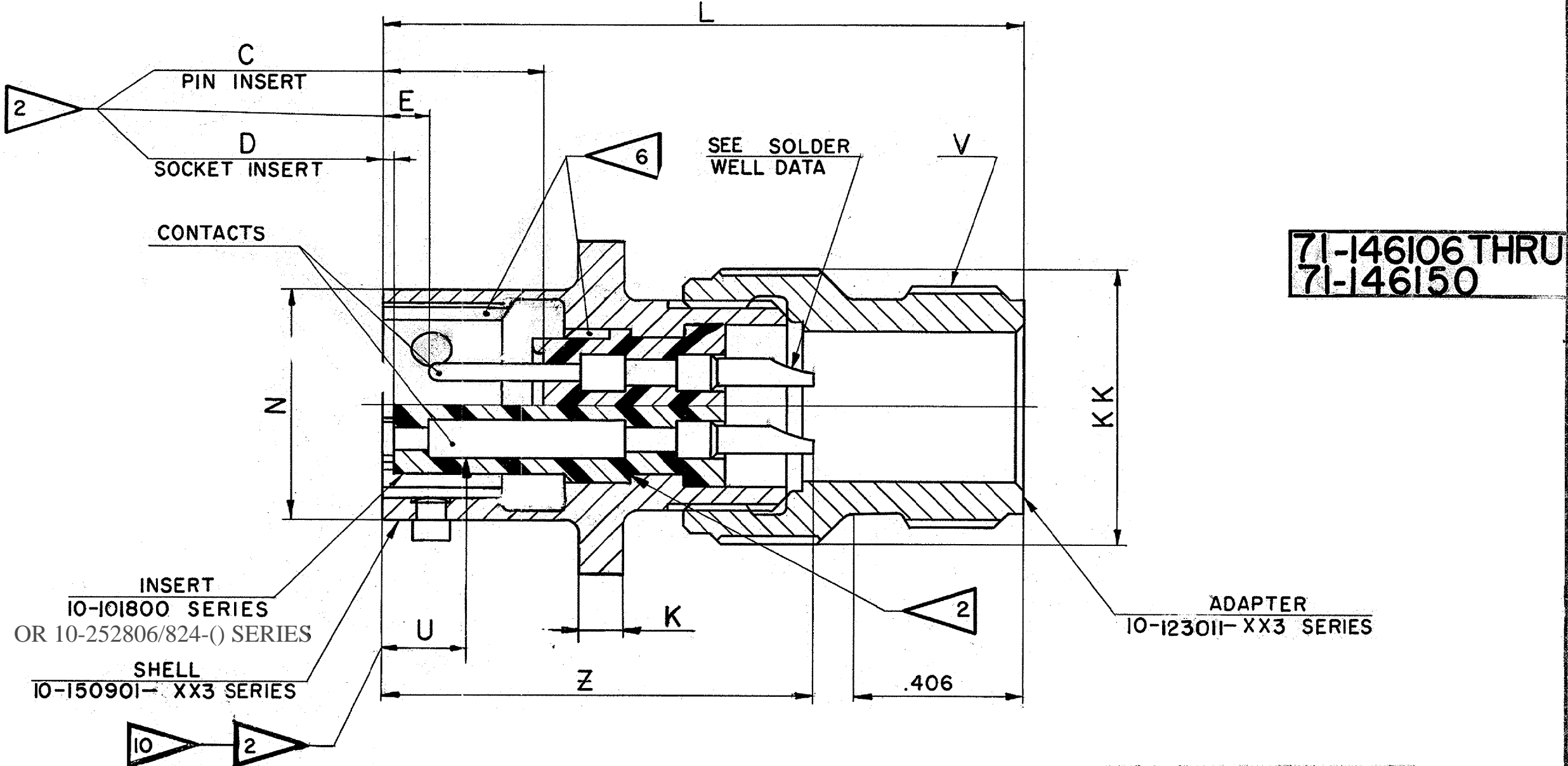
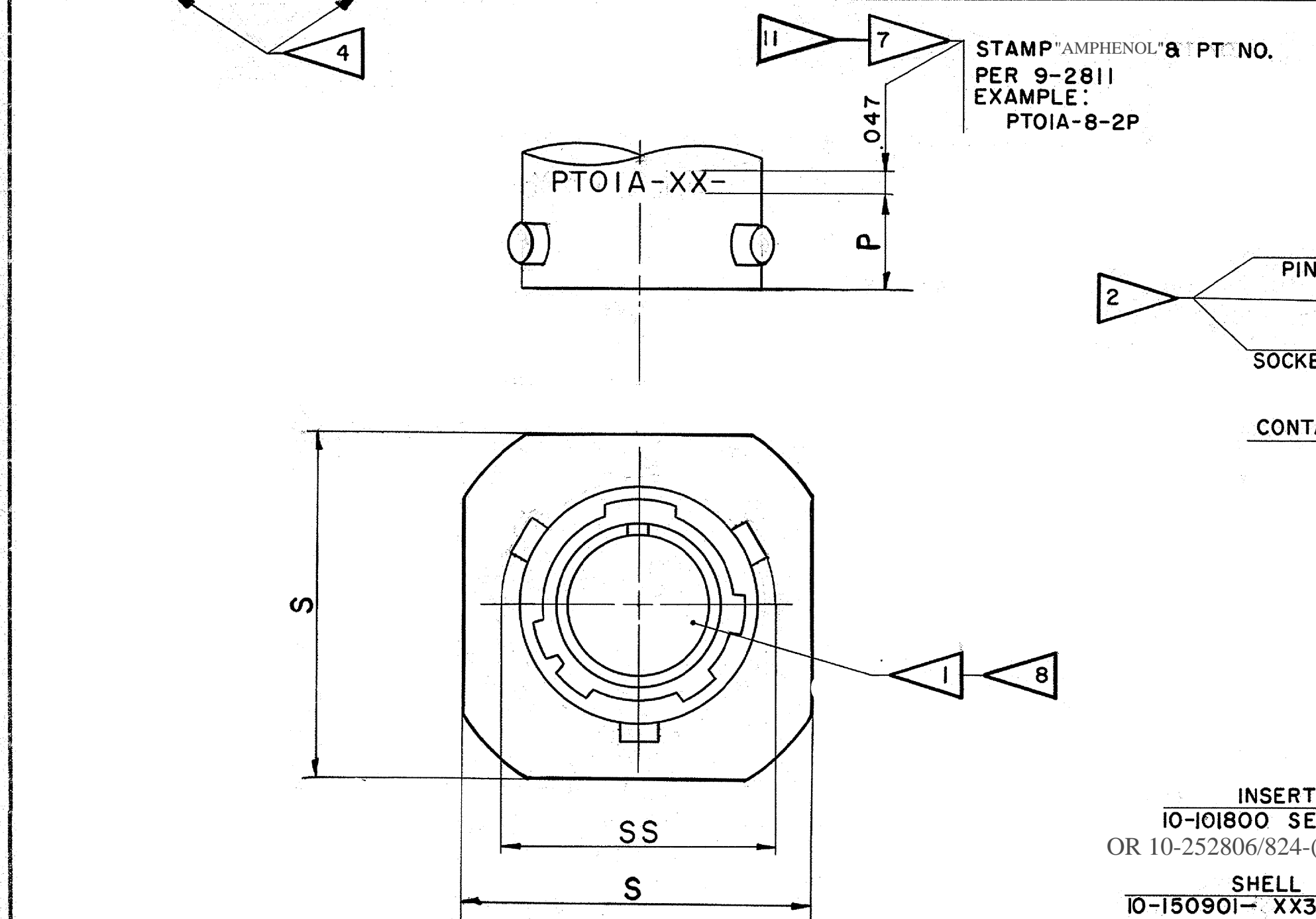

- FOR CONTACT ARRANGEMENTS, SEE DRAWINGS L-15206(-) THRU L-15250(-).
- MATES WITH PLUG 71-146606/50 AND OTHERS.
- FOR COMPONENT PART NUMBERS OF DESIRED ARRANGEMENT, SEE APPLICABLE PARTS LIST.
- TO COMPLETE ASSY NO. & PT NO., ADD APPLICABLE INSERT ARRANGEMENT SUFFIX TO BASE NUMBERS LISTED ABOVE PER 9-2437-1.
- VERTICAL CENTERLINES OF INSERT ARRANGEMENT & THE MAIN SHELL POLARIZING KEYWAY TO BE WITHIN .005 OF INDICATED ROTATION PER 9-2437-1.
- SEE WORK ORDER FOR PERMISSIBLE ADDITIONAL OR ALTERNATE STAMPING.
- INSERTS AND CONTACTS MUST NOT BE REMOVED.
- STAMPING MAY BE ON EITHER SIDE OF FLANGE (ONE SIDE ONLY) OR ON N DIA AS SHOWN.
- DISTANCE BETWEEN END OF SHELL & THE POINT AT WHICH A GAGE PIN, HAVING THE SAME BASIC DIAMETER AS THE MATING CONTACT & A SQUARE FACE, ENGAGES SOCKET CONTACT SPRING.

SOLDER WELL DATA		CONTACT SIZE	
CONTACT SIZE	20	16	
WELL DIA	.046 <sup>+0.004</sup> <sub>-0.000</sub>	.078 <sup>+0.004</sup> <sub>-0.002</sub>	
WELL DEPTH	.125	.188	
MATERIAL SPEC.	PROCESS SPEC. TEST 9-3980-2 ASSY 9-3443-192437-1 9-2811	SCINTILLA MAGNETO DIVISION BENDIX AVIATION CORPORATION SIDNEY, N. Y., U.S.A.	
HEAT TREAT SPEC.	FINISH SPEC.	CONNECTOR, ELECTRICAL PLUG, TYPE PTA ( ) FL. OLIVE DRAB	
TOLERANCES UNLESS OTHERWISE SPECIFIED		FRACTIONS: 1/32 DECIMALS: ±.010 ANGLES: ±2° CONCENTRICITY: .015 FIR: BREAK SHARP EDGES: .010-.030 SQUARENESS: .010 PER INCH OF LENGTH MACHINED SURFACES: MUST BE FLAT AND PARALLEL WITHIN THE TOLERANCE OF THE APPLICABLE DIMENSION AND SMOOTH WITHIN 200 MICRO INCHES RMS.	
D'MAN CHECKER MAT. P STDS CH. D'MAN APPROVED SCALE		NEXT ASSEMBLY WEIGHT LBS SEE PARTSLIST	
IWARD KOVARICK 2-25-57		SUPERSEDES SUPERSEDED BY 71-146106 THRU 71-146150	
TOOL ACC. COM. REC 22532-33 1-11-57		REF. DWG SIZE C TAB. CODE 77820	

## X-ON Electronics

Largest Supplier of Electrical and Electronic Components

*Click to view similar products for [Circular MIL Spec Connector](#) category:*

*Click to view products by [Amphenol](#) manufacturer:*

Other Similar products are found below :

[0025-262-542](#) [0025-264-3014](#) [58-570121-04S](#) [0134-202-1200](#) [0134-207-1206](#) [0134-207-1800](#) [0134-207-2207](#) [0134-213-0806](#) [0134-213-1007](#) [0134-213-1009](#) [0134-213-1208](#) [0134-213-1800](#) [0134-213-2209](#) [0025-258-000](#) [015-9516-002](#) [60-042722-19P](#) [0114-201-1278](#) [602GB06EG24-61SN](#) [0134-201-1207](#) [0134-201-1806](#) [0134-201-2006](#) [0134-201-2007](#) [0134-201-2010](#) [0134-202-1400](#) [0134-207-0809](#) [0134-207-1208](#) [0134-207-2009](#) [0134-213-1006](#) [6104-207-2302](#) [6104-208-1902](#) [6131-202-19149P](#) [6131-204-21149P](#) [6131-207-13149P](#) [6131-208-13149P](#) [6131-209-17149P](#) [6131-210-11149P](#) [6131-211-19149P](#) [6131-216-19149P](#) [6131-220-25149P](#) [6131-259-11149P](#) [6131-259-21149P](#) [6131-259-23149P](#) [6131-263-19149P](#) [6131-265-17149P](#) [6131-265-19149P](#) [CS3102A-20-15P](#) [CS3102A-20-15S](#) [CS3102C18-4P-472](#) [CS3106A-20-29P](#) [CS3106A-20-74P](#)