

VIEW A
ALTERNATE DESIGN OF ACCESSORY
AND COUPLING

REL NO. 33608-96		REVISIONS		
CHG NO.	SYM	DESCRIPTION	DATE	APPROVED
43525-799	A2	REDRAWN SAME SIZE; PROVIDED ENVELOPE DRAWING	11-11-64 W. GAY	<i>Homan</i>
45525-1134	A3	STANDARDIZED	8-11-66 D. BROWN	<i>Homan</i>
26181	B	(CL II) REV COL. L	5/29/92 M. FELL	<i>CM</i>
27790	C	(CL II) ADDED VIEW A	5-21-93 JED	<i>JED</i>
99039	D	(CL II) ADDED 10-252806/824-() ECN: 99039	12-8-06 JONES	

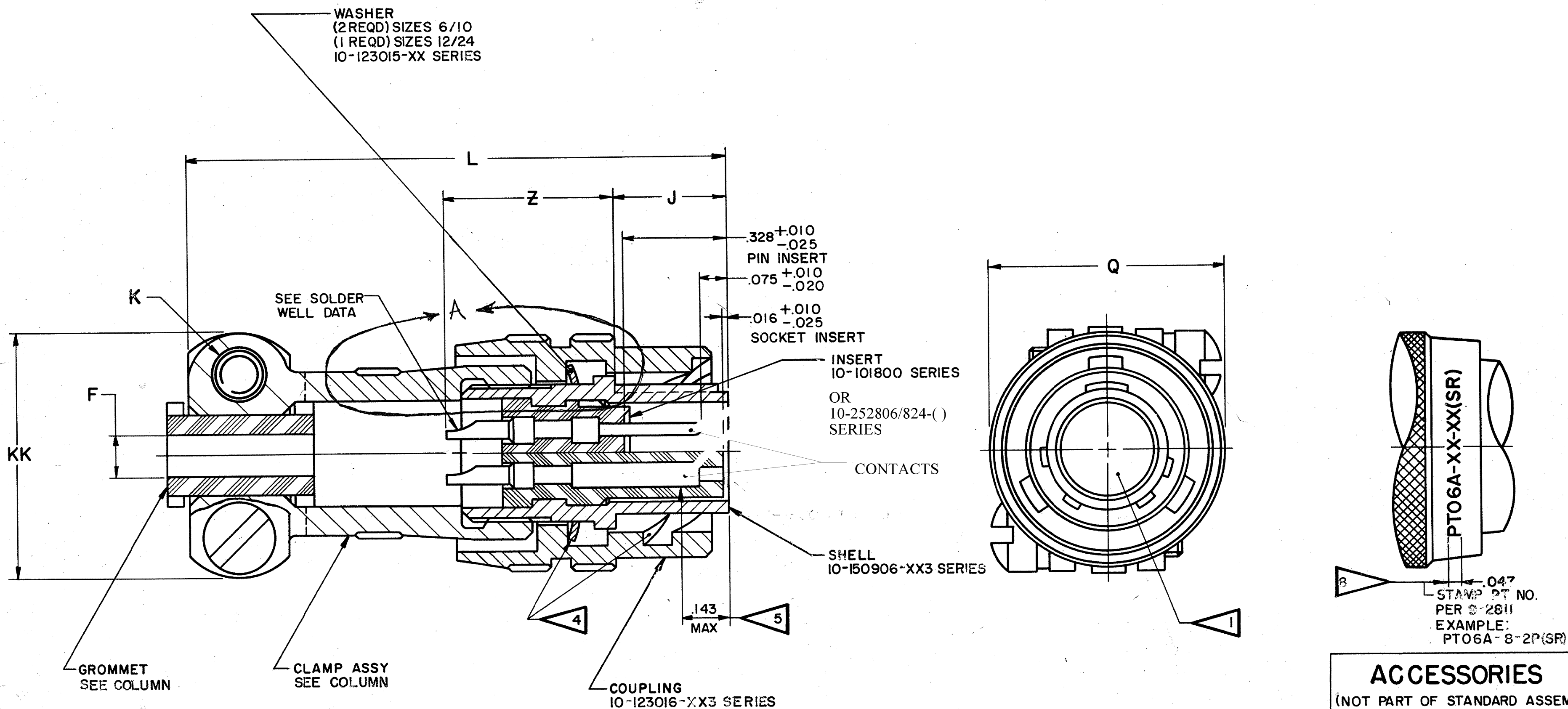

USE OF THIS DOCUMENT IS UNLIMITED. DOCUMENTS REFERENCED HEREON CONTAIN LIMITED RIGHTS DATA.

ACCESSORIES
(NOT PART OF STANDARD ASSEMBLY)

SEE DRAWING
10-150000

ITEM NO.	QTY REQD	DESCRIPTION	PART NUMBER	CODE IDENT	ZONE	NEXT ASSEMBLY
PARTS LIST						
UNLESS OTHERWISE SPECIFIED			DRAWN: F. GEORGE	DATE: 11-10-57	THE Bendix CORPORATION SCINTILLA DIVISION SIDNEY, NEW YORK, U.S.A.	
LINEAR DIMENSIONS ARE IN INCHES. TOLERANCES: 3 PLACES ±.010; 2 PLACES ±.03; 1 PLACE ±.1; ANGLES ±2°. OTHER STANDARDS PER SCINTILLA SPEC 9-3800 AND MIL-STD 8.			CHECKED: <i>S. Lawson</i>	DATE: 7-14-65		
MATERIAL SPEC			STANDARDS: <i>P. Balantieri 4-14-65</i>	ENGINEERING: <i>H. M. Hannon 4-14-65</i>		
PROCESS SPEC SEE SHEET 2			DRAFTING: <i>R. Carr</i>	DEVELOPMENT: <i>R. Carr</i>		
		TITLE: CONNECTOR, ELECTRICAL PLUG, TYPE PT-A()MC(SR), OLIVE DRAB		CODE IDENT NO. 77820	SIZE C	71-150750 THRU 71-150774
		SCALE NONE	WT	REF 71-146606/50	SHEET 1 OF 2	

SEE SHEET 2
NOTES: REF SYMBOL

REL NO. 33508-95		REVISIONS	
CHG NO.	SYM	DESCRIPTION	DATE
		SEE SHEET I FOR ALL CHANGES	
		APPROVED	

ASSEMBLY NUMBER	PT NO.	F DIA	J	L MAX	Q DIA +.000 -0.047	K THD CLASS 2 REF	Z ±.035	KK +.000 -0.047	GROMMET	CLAMP ASSY
71-150750 -	06A-6- (SR)									
71-150751 -	-8-	.125	.353	1.828	.734	6-32UNC	.525	.781	10-36565 -101	10-101987-83
71-150752 -	-10-	.188			.844			.844	-122	-103
71-150753 -	-12-	.312			1.016			.969	-143	-123
71-150754 -	-14-	.375		↓	1.141			1.094	-163	-143
71-150755 -	-16-	.500		1.969	1.266	↓		1.156	-183	-163
71-150756 -	-18-	.625	↓	1.969	1.375	8-32UNC	↓	1.406	-203	-183
71-150757 -	-20-	.625	.415	2.141	1.516		.619	1.406	-203	-203
71-150758 -	-22-	.750		2.141	1.641			1.594	-244	-223
71-150759 -	↓-24-	.800	↓	2.219	1.761	↓	↓	1.688	↓-232	↓-243
71-150760/74				NOT AVAILABLE						

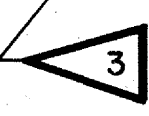

10. FOR ASSEMBLY NUMBERS 71-150754-91, 71-150756-80, 71-150756-90, 71-150756-91, 71-150758-4, 71-150758-7 SEE INDIVIDUAL DRAWING.
9. FOR COMPONENT PART NUMBERS OF DESIRED ARRANGEMENT, SEE APPLICABLE PARTS LISTS.
8. SEE WORK ORDER FOR PERMISSIBLE ADDITIONAL OR ALTERNATE STAMPING.
7. FOR CONTACT ARRANGEMENTS, SEE DRAWINGS L-15206-() THRU L-15250-().
6. UNITS ILLUSTRATED MEET THE MATERIAL & FINISH REQUIREMENTS OF MIL-C-26482.
5. DISTANCE BETWEEN END OF SHELL & THE POINT AT WHICH A GAGE PIN, HAVING THE SAME BASIC DIAMETER AS THE MATING CONTACT & A SQUARE FACE, ENGAGES SOCKET CONTACT SPRING.
4. COUPLING RAMPS & WASHER ARE LUBRICATED

3. FOR COMPLETE ASSEMBLY NUMBER & PT NO., ADD APPLICABLE INSERT ARRANGEMENT SUFFIX TO BASE NUMBERS LISTED ABOVE PER 9-2437-1.
2. FOR MATING RECEPTACLE ASSEMBLY, SEE DRAWING 71-150700/24 & OTHERS.
1. INSERTS & CONTACTS MUST NOT BE REMOVED

NOTES: REF SYMBOL

CONTACT DATA (WHERE APPLICABLE)	
THERMOCOUPLE	
MATERIAL	IDENTIFICATION
CHROMEL	WHITE
ALUMEL	GREEN
IRON	BLACK
CONSTANTAN	YELLOW
INSERT ARRANGEMENTS CONTAINING THERMOCOUPLE CONTACTS MUST HAVE SUCH CONTACTS ASSEMBLED INTO THE INSERT IN PROPER LOCATIONS AS SPECIFIED BY APPLICABLE DRAWINGS L-15206-() THRU L-15250-().	

SOLDER WELL DATA		
CONTACT SIZE	20	16
WELL DIA	046 +.004 -0.000	078 +.004 -0.002
WELL DEPTH	.125 +.031 -0.000	.188 +.031 -0.000

ITEM NO.	QTY REQD	DESCRIPTION	PART NUMBER	CODE IDENT	ZONE	NEXT ASSEMBLY
PARTS LIST						
UNLESS OTHERWISE SPECIFIED		DRAWN: F. GEORGE	DATE: 11-19-57	THE Bendix CORPORATION SCINTILLA DIVISION SIDNEY, NEW YORK, U.S.A. CONNECTOR, ELECTRICAL PLUG, TYPE PT-A()MC(SR), OLIVE DRAB		
LINEAR DIMENSIONS ARE IN INCHES. TOLERANCES: 3 PLACES ±.010; 2 PLACES ±.03; 1 PLACE ±.1; ANGLES ±2°. OTHER STANDARDS PER SCINTILLA SPEC 9-3800 AND MIL-STD 8.		CHECKED: <i>S. Lawson</i>	DATE: 4-14-65			
MATERIAL SPEC		STANDARDS: <i>J. Salantini 4-14-65</i>	DRAFTING: <i>Edmund 4-14-65</i>			
PROCESS SPEC TEST 9-3980-2 ASSY 9-3443-1 9-2437-1 9-2811		ENGINEERING: <i>9/21/65 4-14-65</i>	DEVELOPMENT: <i>R. Carr</i>			
		CODE IDENT NO. 77820		SIZE C	71-150750 THRU 71-150774	
		SCALE NONE		WT	REF 71-146606/50	SHEET 2

X-ON Electronics

Largest Supplier of Electrical and Electronic Components

Click to view similar products for [Circular MIL Spec Connector](#) category:

Click to view products by [Amphenol](#) manufacturer:

Other Similar products are found below :

[89075GULPR](#) [0025-264-3014](#) [58-570121-04S](#) [58-584653-12P](#) [0134-213-1007](#) [0134-213-1208](#) [0134-213-2209](#) [0025-258-000](#) [60-042022-02P](#) [60-042022-19P](#) [60-042022-23P](#) [60-042217-10P](#) [60-042217-11P](#) [012-0467-000](#) [602GB06EG24-61SN](#) [0134-201-1207](#) [0134-207-2009](#) [0134-213-1006](#) [6104-207-2302](#) [6104-208-1902](#) [6131-202-19149P](#) [6131-204-21149P](#) [6131-207-13149P](#) [6131-208-13149P](#) [6131-209-17149P](#) [6131-210-11149P](#) [6131-211-19149P](#) [6131-216-19149P](#) [6131-220-25149P](#) [6131-259-11149P](#) [6131-259-21149P](#) [6131-259-23149P](#) [6131-263-19149P](#) [6131-265-17149P](#) [6131-265-19149P](#) [6134-203-21149](#) [CS3100A18-1P-472](#) [CS3100A-36-77S](#) [CS3101A36-79S-SR](#) [CS3102A-10SL-53P](#) [CS3102A10SL-64S](#) [CS3102A-18-1P116](#) [CS3102A-20-15S](#) [CS3102A-22-70S](#) [CS3102A-24-79S](#) [CS3102A24-AJS](#) [CS3102A-32-17P](#) [CS3102A32-25S](#) [CS3102A-36-78S](#) [CS3106A10SL3S004](#)