

REL NO. 32508-730		REVISIONS		M	
CHG NO.	SYM	DESCRIPTION	DATE	APPROVED	
43525 -846	A2	(MFG); REDRAWN SAME SIZE, PROVIDE ENVELOPE DWG	3-25-65	RAMP	
45525 -959	A3	WAS 10-144606/50 (DWG NO. SHEET 2)	7-5-66	MATTICE	
	B	(CLI) SEE ECN 90826	7/19/62	JED	
95183	C	(OLD) CHANGED STAMPING HEIGHT DIMENSION	7/8/69	JED	
97334	D	(CLI) SEE ECN 97334	11-17-65	JED	

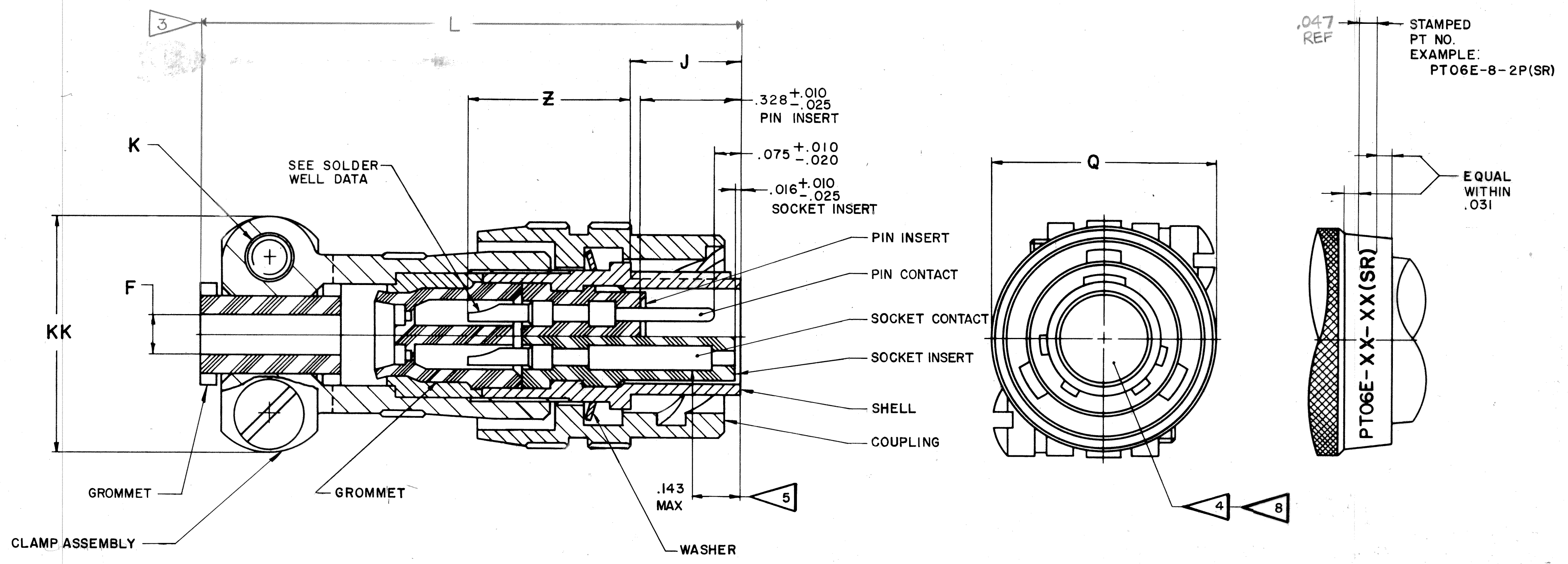

USE OF THIS DOCUMENT IS UNLIMITED. DOCUMENTS REFERENCED HEREON CONTAIN LIMITED RIGHTS DATA.

ITEM NO.	QTY REQD	DESCRIPTION	PART NUMBER	CODE IDENT	ZONE	NEXT ASSEMBLY
PARTS LIST						
UNLESS OTHERWISE SPECIFIED		DRAWN: MOORE	DATE: 5-3-57	<b>THE Bendix CORPORATION</b> <b>SCINTILLA DIVISION</b> SIDNEY, NEW YORK, U.S.A. TITLE: CONNECTOR, ELECTRICAL PLUG, TYPE PT-E()MC, OLIVE DRAB, ENVELOPE DRAWING CODE IDENT NO. 77820 SIZE C 71-144606 THRU 71-144650 SCALE NONE WT REF SHEET 1 OF 2		
LINEAR DIMENSIONS ARE IN INCHES. TOLERANCES: 3 PLACES ±.010; 2 PLACES ±.03; 1 PLACE ±.1; ANGLES ±2°. OTHER STANDARDS PER SCINTILLA SPEC 9-3800 AND MIL-STD 8.		CHECKED: Keller	DATE: 5-10-65			
MATERIAL SPEC	PROCESS SPEC	STANDARDS: J. Balante 5-10-65	DRAFTING: Al Smith 5-10-65			
	SEE SHEET 2	ENGINEERING: J.M. Harmon 5-10-65	DEVELOPMENT: [Signature] 4-21-65			

SEE SHEET 2  
NOTES: REF SYMBOL ◁

REL NO. 32508-230		REVISIONS	M
CHG NO.	SYM	DESCRIPTION	DATE APPROVED
	A2	SEE SHEET I FOR ALL CHANGES	
	A3		
	B		
	C		
	D		

ASSEMBLY NUMBER	PT NO.	F DIA	J	K THRD CLASS 2	L MAX	Q MAX	Z ±.030	KK MAX
71-144606 -	06E-6- (SR)							
NOT AVAILABLE								
71-144608 -	-8-	.125	.353	6-32UNC	1.906	.721	.525	.775
71-144610 -	-10-	.188				.831		.837
71-144612 -	-12-	.312				.997		.963
71-144614 -	-14-	.375				1.125		1.087
71-144616 -	-16-	.500			2.047	1.254		1.150
71-144618 -	-18-	.625		8-32UNC	2.078	1.364		1.400
71-144620 -	-20-	.625	.415		2.250	1.493	.619	1.400
71-144622 -	-22-	.750			2.250	1.621		1.587
71-144624 -	-24-	.800			2.312	1.761		1.681
71-144626/50								
NOT AVAILABLE								

2

1. MATES WITH RECEPTACLES 71-144006/50.
2. TO COMPLETE ASSY NO. & PT NO., ADD APPLICABLE INSERT ARRANGEMENT SUFFIX TO BASE NUMBERS LISTED ABOVE PER 9-2437-1.
3. DIMENSION INDICATES FINAL INSTALLATION.
4. INSERTS & CONTACTS MUST NOT BE REMOVED.
5. DISTANCE BETWEEN END OF SHELL & THE POINT AT WHICH A GAGE PIN, HAVING THE SAME BASIC DIAMETER AS THE MATING CONTACT & A SQUARE FACE, ENGAGES SOCKET CONTACT SPRING.
6. ALL UNUSED GROMMET HOLES TO BE FILLED WITH GROMMET SEALING ROD OR GROMMET SEALING PLUGS. SEE DRAWING 10-150000 (# 27 & # 28).
7. UNITS ILLUSTRATED MEET THE MATERIAL & FINISH REQUIREMENTS OF MIL-C-26482.
8. FOR CONTACT ARRANGEMENTS, SEE DRAWINGS L-15206-() THRU L-15250-().

NOTES: REF SYMBOL

SOLDER WELL DATA		
CONTACT SIZE	20	16
WELL DIA	.046 <sup>+0.004</sup> <sub>-0.000</sub>	.078 <sup>+0.004</sup> <sub>-0.002</sub>
WELL DEPTH	<sup>+0.031</sup> <sub>-0.000</sub>	.125 .188

**ACCESSORIES**  
(NOT PART OF STANDARD ASSEMBLY)

SEE DRAWING  
10-150000

ITEM NO.	QTY REQD	DESCRIPTION	PART NUMBER	CODE IDENT	ZONE	NEXT ASSEMBLY
PARTS LIST						
UNLESS OTHERWISE SPECIFIED		DRAWN: MOORE	DATE: 5-3-57	THE <b>Bendix</b> CORPORATION		
LINEAR DIMENSIONS ARE IN INCHES. TOLERANCES: 3 PLACES ±.010; 2 PLACES ±.03; 1 PLACE ±.1; ANGLES ±2°. OTHER STANDARDS PER SCINTILLA SPEC 9-3800 AND MIL-STD 8.		CHECKED: <i>Kellu</i>	DATE: 5/19/65	SCINTILLA DIVISION SIDNEY, NEW YORK, U.S.A.		
MATERIAL SPEC		MATERIAL:	STANDARDS: <i>J. Balante</i> 5-10-65	TITLE: CONNECTOR, ELECTRICAL PLUG, TYPE PT-E( ) MC, OLIVE DRAB, ENVELOPE DRAWING		
PROCESS SPEC TEST 9-3980-2		DRAFTING: <i>W. Bennett</i> 5-10-65	ENGINEERING: <i>W. Harrison</i> 5-10-65	CODE IDENT NO. 77820	SIZE C	71-144606 THRU 71-144650
9-2437-1		DEVELOPMENT: <i>W. Harrison</i> 4-21-65		SCALE NONE	WT	REF SHEET 2

## X-ON Electronics

Largest Supplier of Electrical and Electronic Components

*Click to view similar products for [Circular MIL Spec Connector](#) category:*

*Click to view products by [Amphenol](#) manufacturer:*

Other Similar products are found below :

[89075GULPR](#) [0025-262-542](#) [0025-264-3014](#) [58-570121-04S](#) [0134-213-1208](#) [0134-213-2209](#) [0025-258-000](#) [60-042022-07P](#) [60-042022-19P](#)  
[60-042022-23P](#) [60-042217-10P](#) [60-042217-11P](#) [0114-201-1278](#) [012-0467-000](#) [602GB06EG24-61SN](#) [0134-201-1207](#) [0134-213-1006](#) [6104-](#)  
[207-2302](#) [6104-208-1902](#) [61-168211-04P](#) [61-168617-10P](#) [6131-202-19149P](#) [6131-204-21149P](#) [6131-208-13149P](#) [6131-209-17149P](#) [6131-](#)  
[210-11149P](#) [6131-211-19149P](#) [6131-216-19149P](#) [6131-259-21149P](#) [6131-259-23149P](#) [6131-265-17149P](#) [6131-265-19149P](#) [CS3100A18-1P-](#)  
[472](#) [CS3100A-36-77P](#) [CS3101A-16-55P](#) [CS3102A-10SL-55P](#) [CS3102A-14S-58P](#) [CS3102A-18-1P116](#) [CS3102A-32-17P](#) [CS3102A32-25S](#)  
[CS3102C18-4P-472](#) [CS3106A10SL3S004](#) [CS3106A-18-73S](#) [CS3108A-14S-52S](#) [CS3108A-28-51S](#) [6162-233-1277](#) [6162-324-1231](#)  
[M243082296Z](#) [M2884010AC1S1](#) [CT0-24-10SC](#)