

ASSEMBLY NUMBER	PT NUMBER	DETAILS SHELL	DIMENSIONS							
			C +020 -000	D +020 -000	J	L MAX	Q DIA +000 -047	Z ±.045	Z <sub>1</sub> ±.045	KK DIA +000 -031
71-331606-	06SE-6-		NOT AVAILABLE							
71-331608-	-8-	10-330906-83	.030	.337	.353	.953	.734	.640	.579	.540
71-331610-	-10-	-103					.844			.685
71-331612-	-12-	-123					1.016			.813
71-331614-	-14-	-143					1.141			.930
71-331616-	-16-	-163					1.266			1.057
71-331618-	-18-	-183					1.375			1.175
71-331620-	-20-	-203	.092	.399	.415	.859	1.516	.578	.517	1.301
71-331622-	-22-	-223				.859	1.641			1.428
71-331624-	-24-	-243				.922	1.761			1.533
71-331625 /50			NOT AVAILABLE							

**ACCESSORIES**  
(NOT PART OF STANDARD ASSEMBLY)

SEE DRAWING  
10-150000

REV NO		36536-115		REVISIONS		DATE	APPROVAL
CHG NO.	SYM	DESCRIPTION		DATE	APPROVAL		
37753-1	1	REDRAWN BY E. MICHEL, WAS SAME SIZE, TEST 9-3897-1, ASSY 9-3836-1 (PRO SPEC), ADD -24 & DATA, NOTES 12, 13 14, REV NOTE 11.		7-21-60	<i>S. Land</i>		
38311-2	2	REV NOTE II.		8-18-61	<i>S. Land</i>		
39070-2	3	RELOC AND REV C & D DIM		1-4-62	<i>S. Land</i>		
36525-374	4	ADD ENLARGED VIEW OF COAXIAL CONTACT TERMINATION & DATA		1-23-62	<i>S. Land</i>		
39606-19	A1	WAS NUT 10-330911-XX3 SERIES, REV L MAX COL, RELOC L DIM.		4-18-62	<i>S. Land</i>		
42525-330	A2	WAS .184, .234, .077 (WIRE WELL DATA)		1-7-64	<i>S. Land</i>		
45525-425	A3	REM COAX. TERMINATION VIEW, REV COAXIAL WELL DATA BLOCK; NOTE ONE, NOTE 11; ADD SIZE 12 & SIZE 12 FOR 10 TO WIRE WELL DATA BLOCK.		2-2-66	<i>S. Land</i>		
55524-218	A4	ADD & REL -8 & DATA		5-7-74	<i>S. Land</i>		
55525-288	A5	REV NOTE 11		7-22-74	<i>S. Land</i>		
56525-56	A6	REV C COL		12-2-74	<i>S. Land</i>		

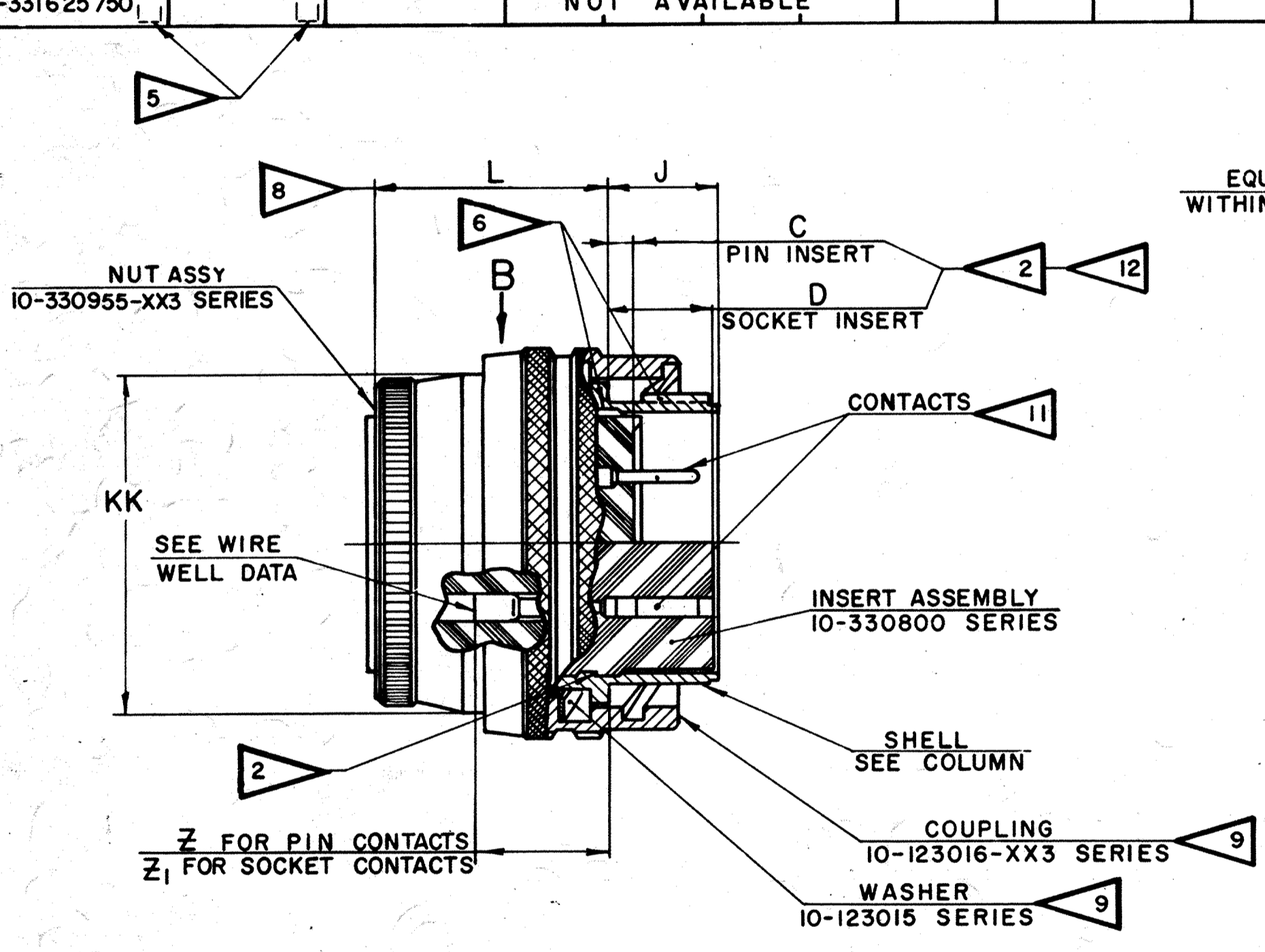

STAMP  
PT NUMBER  
PER 9-2811  
EXAMPLE:  
PT 06SE-10-6P

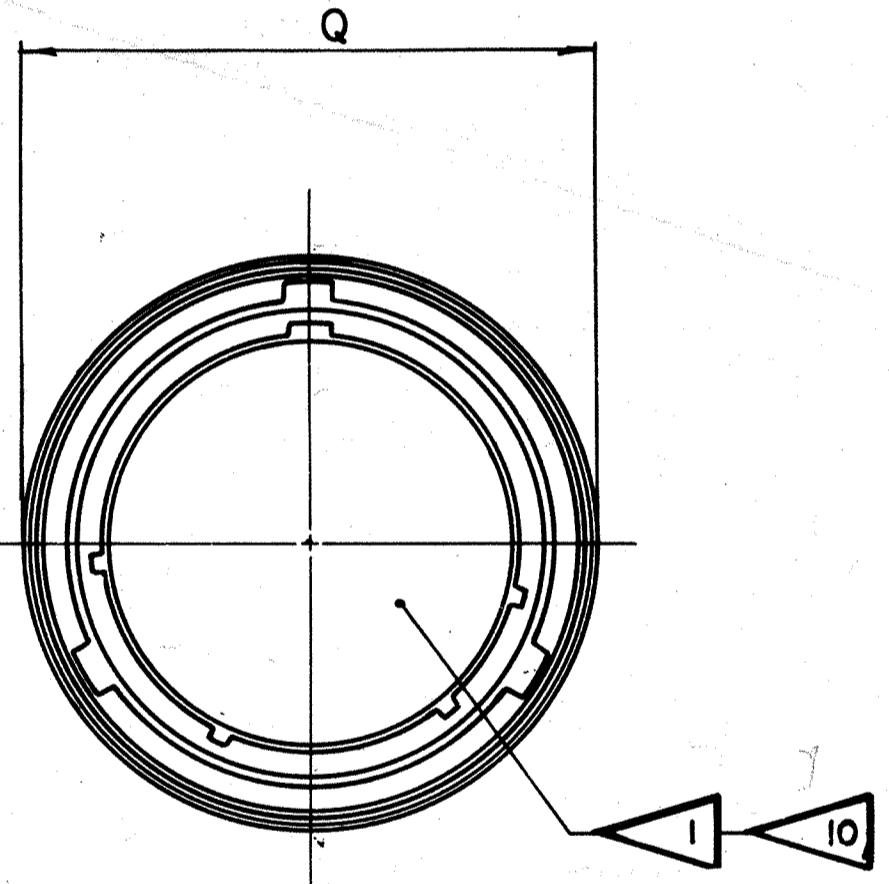
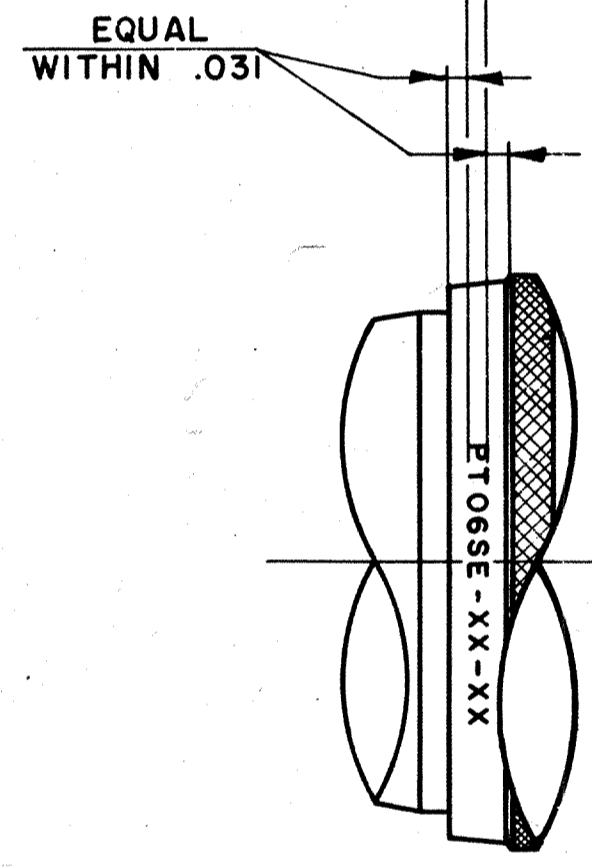

USE OF THIS DOCUMENT IS UNLIMITED. DOCUMENTS REFERENCED HEREON CONTAIN LIMITED RIGHTS DATA.

COAXIAL DATA  
SEE NOTE 1

WIRE WELL DATA				
CONTACT SIZE	20	16	12	12 FOR 10
CONDUCTOR WELL DIA	.048 +.002 -.000	.066 +.002 -.000	.100 ±.002	.136 ±.002
CONDUCTOR WELL DEPTH	.189 +.037 -.000	.250 +.031 -.000	.250 +.031 -.000	.234 +.031 -.000
INSULATION WELL DIA	.091 +.002 -.000	NOT AVAILABLE	NOT AVAILABLE	NOT AVAILABLE
INSULATION WELL DEPTH	.072 +.006 -.000	NOT AVAILABLE	NOT AVAILABLE	NOT AVAILABLE

7. SEE WORK ORDER FOR PERMISSIBLE ADDITIONAL OR ALTERNATE STAMPING.
  6. VERTICAL CENTERLINES OF INSERT ARRANGEMENT AND SHELL POLARIZING KEY MUST BE WITHIN .005 OF INDICATED ROTATION PER 9-2437-1.
  5. TO COMPLETE ASSY NO. & PT NO., ADD APPLICABLE INSERT ARRANGEMENT SUFFIX TO BASE NUMBERS LISTED ABOVE PER 9-2437-1.
  4. FOR COMPONENT PART NUMBERS OF DESIRED ARRANGEMENT, SEE APPLICABLE PARTS LIST (PL).
  3. MATES WITH RECEPTACLE 71-331006/50 & OTHERS.
  2. DIMENSIONS MUST BE MAINTAINED WHEN INSERTS ARE PRESSED FIRMLY AGAINST INDICATED SHOULDER.
  1. FOR CONTACT ARRANGEMENTS & COAXIAL CONTACT DATA, SEE DRAWINGS L-15206-() THRU L-15250-().
  14. UNITS ILLUSTRATED MEET THE MATERIAL AND FINISH REQUIREMENTS OF MIL-C-26482.
  13. FOR FINAL INSTALLATION, CONTACTS MUST BE ASSEMBLED INTO ALL INSERT HOLES. ALL UNUSED GROMMET HOLES MUST BE FILLED WITH APPROPRIATE SEALING PLUG 10-101033.
  12. INSERT LOCATING DIMENSIONS APPLY BEFORE ASSEMBLY OF CONTACTS.
  11. SEE INDIVIDUAL DRAWINGS FOR 71-331614-22, 71-331614-91, 71-331618-91 AND 71-331622-96.
  10. INSERT ASSEMBLIES ARE NOT REMOVABLE.
  9. COUPLING SLOTS & WASHER TO BE LUBRICATED PER 9-3502.
  8. DIMENSION INDICATES FINAL INSTALLATION, FOR STORAGE & SHIPPING, SHELL AND NUT MUST BE LOOSELY COUPLED.
- NOTES: REF SYMBOL ◁

TEST 9-4039-1 ASSY 9-3836-2, 9-2437-1 9-3502, 9-2811	
UNLESS OTHERWISE SPECIFIED	ABBREVIATIONS & SYMBOLS (MNC)-MAXIMUM MATERIAL CONDITION (TP)-TRUE POSITION
1. TOLERANCES: LINEAR .000 ± .010, .00 ± .02, .0 ± .1	ORIG ENG JOB NO. 99G
2. ALL LOCATION TOLERANCES APPLY AT MAXIMUM MATERIAL CONDITION (MNC).	DRAWN: E FLEMING
3. RADIUS FILLETS & BREAK EDGES .005-.020.	DATE: 4-4-60
4. CONCENTRICITY: .015 TIR REGARDLESS OF SIZE.	CHECKED: Mero
FOR DRAWING INTERPRETATION SEE SPEC 9-3800	DATE: 12-14-60
MATERIAL SPEC	HEAT TREAT SPEC
FINISH SPEC	

ITEM	REQD	PART NO.	DESCRIPTION	UNIT WT	NEXT ASSY	USED ON
LIST OF MATERIAL						
APPLICATION						
CONNECTOR, ELECTRICAL PLUG, TYPE PT-SE()MC, OLIVE DRAB						
SCINTILLA DIVISION BENDIX AVIATION CORPORATION SIDNEY, N.Y., U.S.A.						
71-331606 THRU 71-331650						
SCALE: NONE	WT CALC (SEE ACT. PL)	LBS	REF 71-196606/50	DRAWING SIZE: C	TAB	

71-331606 THRU 71-331650

## X-ON Electronics

Largest Supplier of Electrical and Electronic Components

*Click to view similar products for [Circular MIL Spec Connector](#) category:*

*Click to view products by [Amphenol](#) manufacturer:*

Other Similar products are found below :

[89075GULPR](#) [0025-262-542](#) [0025-264-3014](#) [58-570121-04S](#) [0134-213-1208](#) [0134-213-2209](#) [0025-258-000](#) [60-042022-07P](#) [60-042022-19P](#)  
[60-042022-23P](#) [60-042217-10P](#) [0114-201-1278](#) [012-0467-000](#) [602GB06EG24-61SN](#) [0134-201-1207](#) [0134-213-1006](#) [6104-207-2302](#) [6104-](#)  
[208-1902](#) [61-168211-04P](#) [61-168617-10P](#) [6131-202-19149P](#) [6131-204-21149P](#) [6131-208-13149P](#) [6131-209-17149P](#) [6131-210-11149P](#) [6131-](#)  
[211-19149P](#) [6131-216-19149P](#) [6131-259-21149P](#) [6131-259-23149P](#) [6131-265-17149P](#) [6131-265-19149P](#) [CS3100A18-1P-472](#) [CS3100A-36-](#)  
[77P](#) [CS3101A-16-55P](#) [CS3102A-10SL-55P](#) [CS3102A-14S-58P](#) [CS3102A-32-17P](#) [CS3102A32-25S](#) [CS3102C18-4P-472](#)  
[CS3106A10SL3S004](#) [CS3106A-18-73S](#) [CS3108A-14S-52S](#) [CS3108A-28-51S](#) [6162-233-1277](#) [6162-324-1231](#) [M243082296Z](#)  
[M2884010AC1S1](#) [CT0-24-10SC](#) [CT0M20-7PCAU](#) [M28840/17AC1G3](#)