

ReferenceMate portable reference source
REF2500 operation manual





Caution: This guide should be read carefully before operating the unit.

Safety section

ReferenceMate handheld shakers can be used safely when the instructions in this manual are carefully followed. This section summarizes the safety considerations. Reminders in the form shown below will appear in the detailed instructions to assure operator awareness of these safety considerations. Qualified personnel should use the REF2500 only after becoming thoroughly familiar with this manual.



WARNING: This symbol is used in the instruction manual when the safety of the operator must be considered. The instruction manual should be consulted and read carefully.



CAUTION: This symbol is used when caution is needed to prevent damage to equipment. It is used where careful attention to certain procedures described in the instruction manual is needed. This symbol is also used to emphasize procedures other than normal operating procedures.

Safety summary

1. The products covered in this installation guide do not require any special precautions, protective devices, or equipment.
2. Because these products are designed to be used in an industrial environment, personnel involved with the operation of this instrument should be familiar with all plant safety requirements before beginning use.
3. The ReferenceMate is NOT certified for use in explosive or hazardous environments.
4. There are no user-serviceable parts within this product.
5. Use common sense and avoid haste during operation.



Contents

1.0	Introduction	4
2.0	Description.....	4
3.0	Applicable models.....	4
4.0	Set-up.....	5
5.0	Operation	6
5.1	Operating steps.....	6
5.2	Operational details	7
5.2.1	<i>Mounting.....</i>	<i>9</i>
5.2.2	<i>Power ON/OFF.....</i>	<i>9</i>
5.2.3	<i>Frequency selection.....</i>	<i>10</i>
5.2.4	<i>RMS/PEAK.....</i>	<i>10</i>
5.2.5	<i>BAT (low power) LED.....</i>	<i>10</i>
5.2.6	<i>OOR LED.....</i>	<i>11</i>
5.2.7	<i>Orientation during operation.....</i>	<i>11</i>
6.0	Testing triaxial transducers.....	12
6.1	Universal AC adaptor.....	12
7.0	Reference test points	13
7.1	Background information	13
7.2	Recommended instrumentation set-up	14
7.3	Protection from the environment	15
8.0	Storage.....	15
9.0	Technical assistance and customer service	15



1.0 Introduction

This guide is designed to assist the user in the proper operation of the ReferenceMate portable reference source (handheld shaker). Further information is provided on the use of accessory items.

2.0 Description

The ReferenceMate portable vibration reference source enables users in the field to easily verify sensor performance and the integrity of the cabling between the sensor and read-out equipment, either online or portable units.

A built-in reference accelerometer assures that a 1 g test level is maintained for a unit under test (sensor and mounting hardware) weighing up to 250 grams.

Frequency of operation and measurement types (peak/RMS) are selected with front panel push buttons.

- 61.4 Hz for imperial measurements, where 1 g is equal to 1 inch per second (ips), ideal for use with velocity sensors
- 100 Hz to confirm accelerometer performance at the same reference frequency used by most manufacturers
- 159.2 for metric measurements, where 1 g is equal to 9.81 m/sec² and 9.81 mm/sec.



A bottom-mounted D-ring belt clip is included for hands-free transport between locations when in the field. The belt clip can be removed and replaced with a 70 lbf pull force magnet (optional) for attachment to metal structures for hands-free operation.

LEDs notify the user when the battery condition falls below operational levels or if the unit is overloaded. Reference test points are provided to test and check calibration of the shaker's internal accelerometer.

3.0 Applicable models

The manual covers the model REF2500 handheld shaker included in the REF2510 and REF2510R kits, and the use of applicable accessories, both standard and optional.



4.0 Set-up

The unit is powered by four AA alkaline batteries (provided with the unit). Rechargeable and lithium batteries may also be used.



NOTE: Never mix battery types. For proper operation, use all alkaline, NiCad, etc. types. When replacing batteries, always replace all four cells.

Access the battery compartment by unscrewing and removing the bottom cap (see figure 1A). Remove the battery holder and insert four AA batteries into the holder, being careful to observe correct polarity (see figure 1B). After the batteries are installed, insert the holder into the battery cup and gently snap the holder onto the contacts. Re-attach the bottom cap. The ReferenceMate is now ready to operate.

The shaker does not contain a battery charging system. If rechargeable batteries are used, they must be charged external to the shaker.



Figure 1A: ReferenceMate with bottom cap removed showing battery holder



Figure 1B: ReferenceMate with battery holder removed from battery compartment



5.0 Operation

Below are numbered steps to follow for operating the REF2500. Each step is described in detail in section 5.2.



WARNING: The REF2500 is **NOT** certified for use in hazardous environments.

5.1 Operating steps

Please refer to Figure 2 for details.

1. The ReferenceMate is provided with a mounting head that accepts a 1/4-28 mounting stud. Attach the unit to be tested (UUT- accelerometer, piezovelocity sensor, etc.) to the ReferenceMate mounting platform, making certain to only hand-tighten the accelerometer to no more than 10 in-lb (112 N-cm). If the accelerometer has something other than a 1/4-28 mounting thread, use the appropriate adaptor outlined in Table 2. The appropriate mounting torques for adaptors used with the REF2500 are also shown in Table 2. An open end wrench is provided to stabilize the shaker head and make certain the mounting platform (shaker head) is not excessively torqued. Over torquing the shaker head can result in permanent damage to the shaker suspension system. To stabilize the shaker head during accelerometer attachment, slip the open end of the wrench over the flats provided on the shaker head.
2. Once the UUT (and any mounting accessory) is mounted to the ReferenceMate head, connect all cables from the UUT to the readout equipment. You are now ready to test your device.
3. Press the **ON/OFF** button to initiate the 1 g test cycle. The **OOR** indicator (out of range indicator) will come on momentarily as the control circuit stabilizes to a 1 g test level. The shaker will shut off after approximately 90 seconds.
 - a. Allow at least three seconds for the REF2500 to achieve the controlled vibration level. Observe the **BAT** and **OOR** LEDs and make sure they are not illuminated. If the **BAT** indicator remains on, or if the unit will not stay on after releasing the **ON/OFF** switch, replace the batteries and try again. If the **OOR** LED illuminates, the maximum load has been exceeded. The excessive weight must be removed, otherwise a 1 g test level will not be achieved.
 - b. To defeat the auto shutoff feature and enable continuous operation, press and hold the **FREQ** button while turning the unit on. After the unit turns on, all three frequency LEDs will briefly illuminate to indicate the shaker is in CONTINUOUS operating mode. The ReferenceMate will now continue to operate until the **ON/OFF** button is depressed again. This feature may be useful when the ReferenceMate is connected to an AC supply, such as in a laboratory environment. See Section 6.1.

When the unit is turned off, it will revert to the AUTO-OFF mode.



- Once the REF2500 has been turned on and stabilized, a frequency LED and measurement type LED will illuminate. They will indicate the choices made when the shaker was last turned off. To change the frequency (61.4, 100.0 or 159.2 Hz), press and release the **FREQ** button. The frequency LED will toggle through the above three choices each time the **FREQ** button is pressed. To change the measurement type, press and hold the **FREQ** button for approximately 5 seconds. The measurement type will toggle between RMS and Peak each time the **FREQ** button is pressed and held this way.
- To turn the ReferenceMate off before the end of its autosutdown cycle, press the **ON/OFF** button.

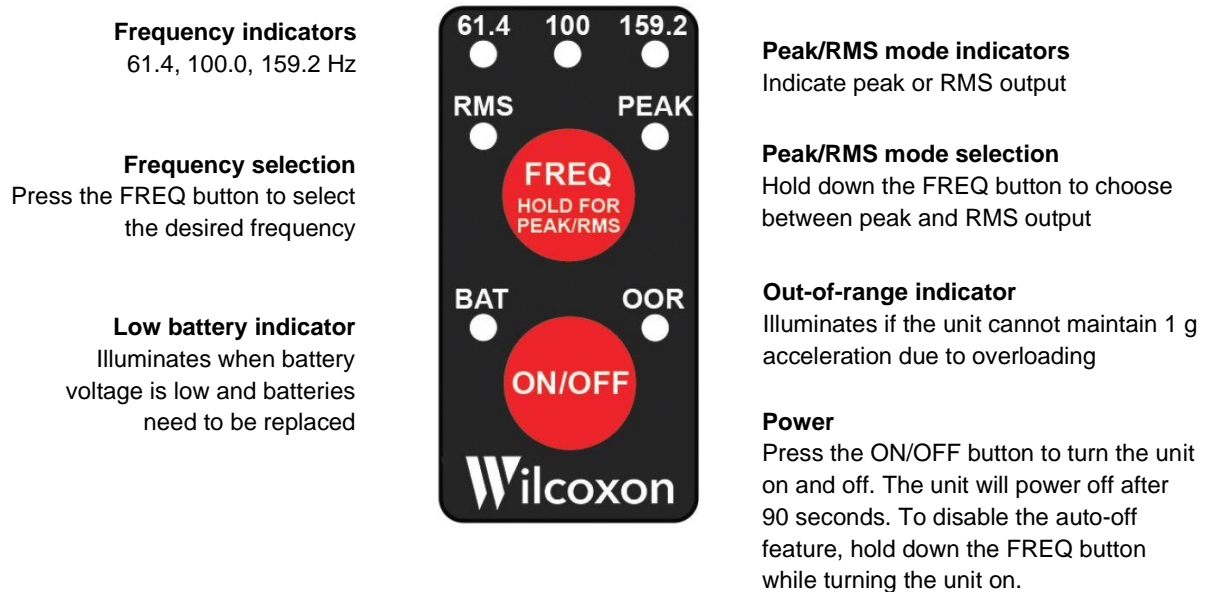

Figure 2: Control panel of the ReferenceMate

5.2 Operational details

Once the UUT has been mounted on the ReferenceMate and a 1 g test level has been achieved, you can check the output of your sensor.

Table 1 shows the relationship between acceleration, velocity and displacement at the three test frequencies. If taking imperial measurements (US) use Table 1a and select 61.4 Hz as your frequency. 1 g (acceleration) at 61.4 Hz is equivalent to 1 in/sec (velocity). If Peak measurement type is selected, both acceleration and velocity will be peak levels. Conversely, if RMS is the measurement type, then both values will be in RMS.



The equivalent peak to peak displacement values in mils are shown in Table 1a for reference. For those using the metric system, Table 1b shows the equivalent values. All the values below are represented in Graph 1.

Table 1a: English (1 g)

Frequency		Velocity	Displacement	
Hz	CPM	in/sec	mils, peak-peak	
			Peak mode	RMS mode
61.4	3684	1.00	5.18	7.34
100.0	6000	0.61	1.96	2.76
159.2	9552	0.39	0.77	1.09

Table 1b: Metric (1 g = 9.81 m/s²)

Frequency		Velocity	Displacement	
Hz	CPM	mm/sec	μm, rms	
			Peak mode	RMS mode
61.4	3684	25.41	5.18	7.34
100.0	6000	15.61	1.96	2.76
159.2	9552	9.81	0.77	1.09

Graph 1: The relationships between 61.4 Hz, 100 Hz, and 159.2 Hz

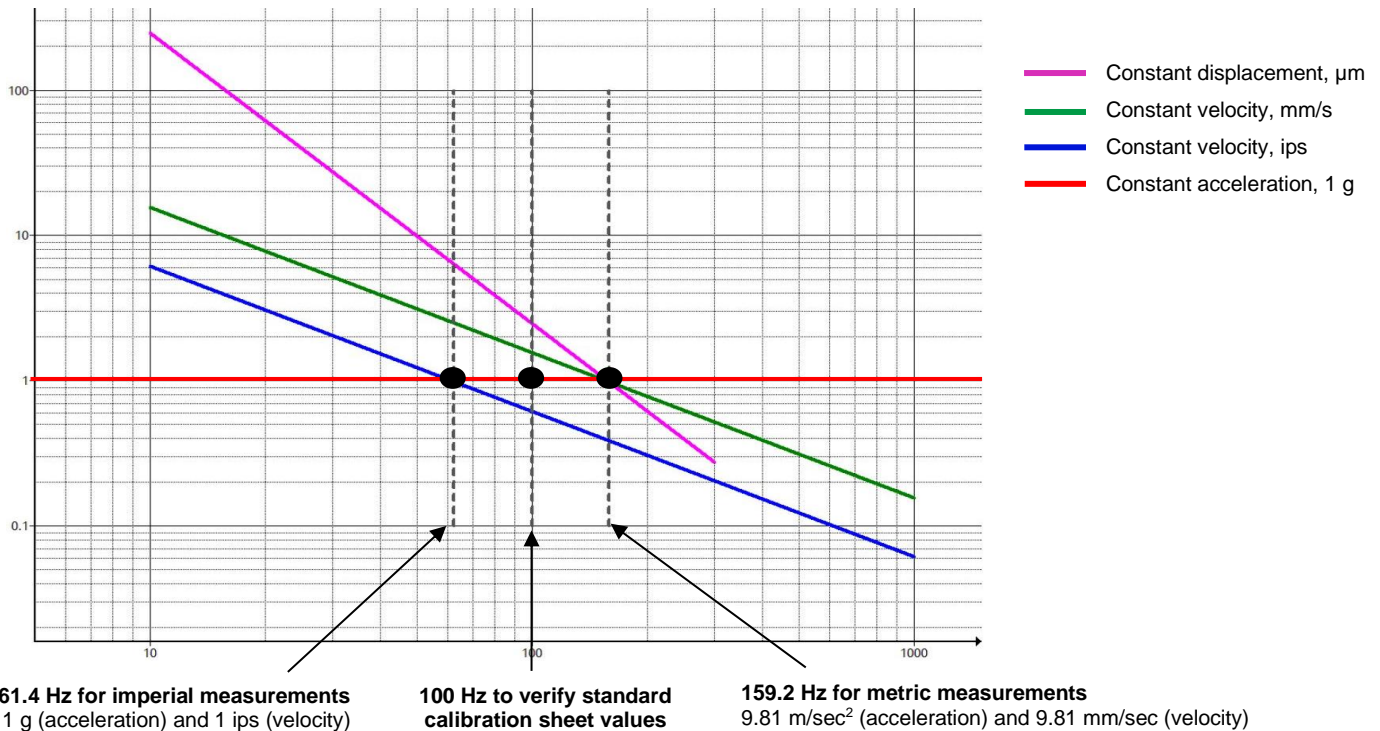



5.2.1 Mounting

The UUT can be attached directly to the shaker head using a 1/4-28 stud. Adaptor studs and plates are available for mounting sensors with different size mounting threads. See Table 2 below.



NOTE: The stud or adaptor plate should be mounted finger tight only, not exceeding 10 in-lb (112 N-cm) into the shaker head. Exceeding the maximum torque may damage the shaker. It is recommended to use the open end wrench when mounting sensors to stabilize the shaker armature.



Table 2: Recommended torque values for standard and optional accessories

Standard mounting accessory for REF2510 and REF2510R kits					
Part number	Description	Rec. torque		REF2510	REF2510R
		in-lb	N-m		
SF6	1/4-28 to 1/4-28 mounting stud	24	2.7	✓	✓

Optional mounting accessories					
Part number	Description	Rec. torque		REF001	REF002
		in-lb	N-m		
SF3	1/4-28 to 10-32 adaptor stud	24 (18)	2.7 (2.0)	✓	
13249-01	1/4-28 to 8-32 adaptor plate (997 and 712 sensors)	24 (20)	2.7 (2.3)	✓	
13249-02	1/4-28 to 10-32 adaptor plate	24 (18)	2.7 (2.0)	✓	
13267-01	90° adaptor plate (993 series sensors)	24 (24)	2.7 (2.7)	✓	
SF6M-1	1/4-28 to M6 adaptor stud	24 (30)	2.7 (3.4)		✓
SF6M	1/4-28 to M8 adaptor stud	24 (40)	2.7 (4.5)		✓
13249-03	1/4-28 to M4 adaptor plate (997 and 712 sensors)	24 (20)	2.7 (2.3)		✓
13249-04	1/4-28 to M6 adaptor plate (captive screw sensors)	24 (30)	2.7 (3.4)		✓
13249-05	1/4-28 to M8 adaptor plate (captive screw sensors)	24 (40)	2.7 (4.5)		✓

A specially designed angular plate is available for calibrating the 993B-7-M12 triaxial accelerometer. This plate will excite all three axes simultaneously, resulting in 0.57 g per axis. See section 6.0.

5.2.2 Power ON/OFF

Turns on the shaker for approximately 90 seconds. The unit will default to the previously selected options. To defeat the auto shutoff feature and enable continuous operation, hold down the **FREQ** button while turning the unit on. All three frequency LEDs will briefly illuminate to indicate the shaker is in CONTINUOUS operating mode. The unit will now operate until the **ON/OFF** button is pressed again. When the unit is turned off, it will revert to the AUTO-OFF mode.



5.2.3 Frequency selection

The user has a choice of three frequencies. Momentarily press the **FREQ** button to select the desired frequency as indicated on the respective LED. During frequency changes, the output of the shaker is turned off momentarily. It is normal for the **OOR** indicator to illuminate briefly after a new frequency is selected. See table 1 for additional information.

The ReferenceMate 2500 will always produce an amplitude of 1 g at the selected frequency.

- 61.4 Hz is the most common frequency selected for machinery vibration and analysis when working with imperial units (US). One g at 61.4 Hz is equal to 1 in/sec (ips) velocity.
- 100 Hz is the preferred frequency for checking accelerometer performance against calibration data. 100 Hz is the most common reference frequency used by accelerometer manufacturers, thus allowing for a comparison with the original calibration certificate.
- 159.2 Hz is the most common frequency used when working in metric units where 1 g is equal to 9.81 m/sec² acceleration, 9.81 mm/sec velocity and 9.8 μm displacement.

5.2.4 RMS/PEAK

Select between **RMS** and **PEAK** by holding down the **FREQ** button. Figure 3 below illustrates the relationship between **PEAK** and **RMS**.

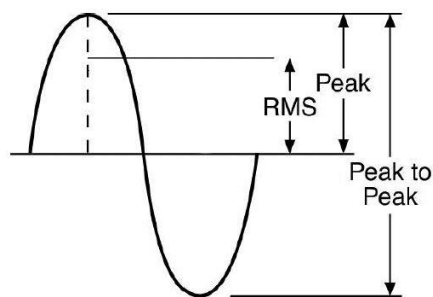

$$\begin{aligned} \text{RMS value} &= 0.707 \times \text{peak value} \\ \text{Peak value} &= 1.414 \times \text{RMS value} \\ \text{Peak to peak value} &= 2 \times \text{peak value} \\ \text{Peak to peak value} &= 2.828 \times \text{RMS value} \end{aligned}$$

Figure 3: the relationship between peak, RMS, and peak-to-peak

5.2.5 BAT (low power) LED

The red **BAT** LED indicates remaining battery life is short and the batteries should be replaced soon. (See section 4 for battery installation instructions). If the battery voltage becomes too low, the unit will shut off and will not operate. The internal power supply is well regulated and 1g acceleration will be maintained even though the battery voltage fluctuates.

Battery life is dependent on the type of batteries used, weight of the load and if the shaker is being operated in the Peak or RMS mode. Table 3 shows approximate battery life expectancy



under various payloads and is based on operating the shaker in RMS mode. Operation in Peak mode will result in longer run times.

Table 3: Battery life expectancy in continuous mode

	Payload (grams)	Alkaline Energizer EN91 1500-1800 mAh		NiMH rechargeable Energizer NH15-2300 2300 mAh		Lithium Energizer L91 3000 mAh	
		Hours	90 sec cycles	Hours	90 sec cycles	Hours	90 sec cycles
61.4 Hz	16	12	480	13	501	18	720
	90	20	800	49	767	36	1440
	254	32	1280	29	1160	42	1680
100.0 Hz	16	32	1280	29	1175	45	1800
	90	31	1250	24	968	45	1800
	254	8	320	10	400	15	600
159.2 Hz	16	32	1280	29	1143	43	1720
	90	24	960	21	836	40	1600
	254	6	240	8	305	12	480

5.2.6 OOR LED

The control time is the required for the unit to achieve the controlled vibration level. The red **OOR** LED will be illuminated during the control time cycle. Once the LED goes out, the unit is ready for operation. This is normally less than 3 seconds.

5.2.7 Orientation during operation

The ReferenceMate may be held in any position during operation without worry of causing an error in the reading. If the control circuitry is unable to maintain 1g test level, the red **OOR** LED will illuminate. Low battery power or a total load exceeding 250 grams can also cause this condition. When considering the total payload on the shaker, attention must also be given to weights of the sensor, mounting method (stud or adaptor) and the cable and connector.



6.0 Testing triaxial transducers

An optional triaxial accelerometer angled adaptor can be purchased separately (part number TAA01). The fixture has a mounting surface that has been designed to excite all of the sensor's axes simultaneously. The resulting vibration level will be approximately 57.8% of the applied acceleration. It is important that the sensor be mounted using its positioning pin to achieve the desired result.

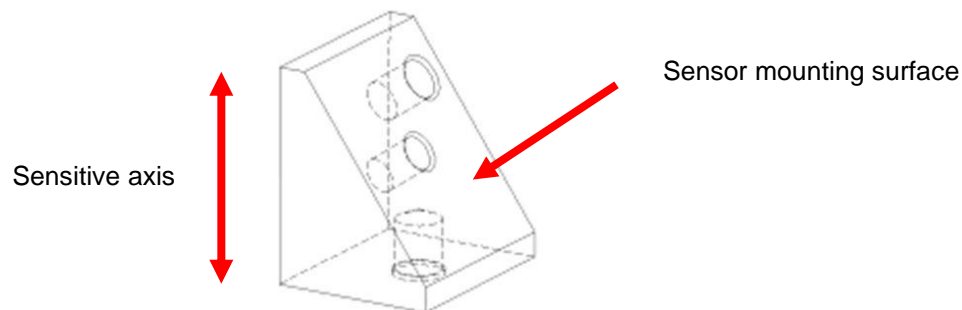

Figure 4: Triaxial mounting adaptor that allows for simultaneous excitation of all three axes

Note that there are two holes on the mounting surface. The 10-32 threaded hole is for mounting the sensor, the unthreaded hole is to accommodate the alignment pin provided on the 993B-7-M12 accelerometer. The weight of the fixture is 93 grams.

6.1 Universal AC adaptor

If AC operation of the ReferenceMate2500 is required, part number REF003 is available. This AC adaptor comes with several universal plug adaptors and will operate from 50/60 Hz 110/220 VAC.

To power the shaker with the AC adaptor, unscrew and remove the DC jack cover on the rear of the unit. Store the jack cover in a safe location. Connect the coaxial power plug of the power supply to the DC jack on the ReferenceMate. When the power plug is inserted into the DC jack, the batteries are automatically disconnected. After connecting the adaptor to the shaker, plug the adaptor into an AC supply.



CAUTION: The external supply is rated for indoor use only. The shaker should not be powered with an external supply when used outdoors or in wet locations. The shaker does not meet the IP54 rating when the DC jack cover is not securely installed. The DC jack cover should always be installed whenever an external supply is not being used.

Voltage: 6 VDC
Current: 800 mA
Plug: 2.1 mm, center conductor positive

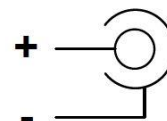



7.0 Reference test points

Test points located in the battery compartment allow access to the control voltage used as part of the motor feedback loop. Using an accurate AC DMM and/or an oscilloscope can help make a determination as to the condition of the unit.

To access the reference test points, remove the battery cover (see section 4) and find the two turret style connectors and connect the desired test leads. The “+” terminal is the AC output voltage. The “-” terminal is system ground.



CAUTION: When accessing the test points, proper precautions should be taken against ESD (electrostatic discharge). Checking the test point voltage should be done only in an ESD-safe environment.

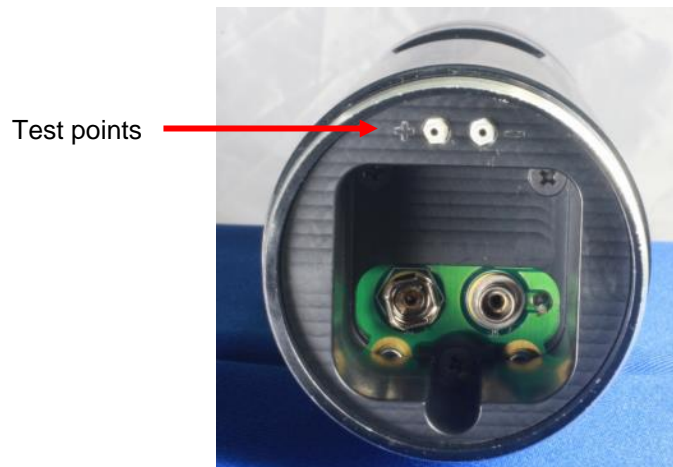

Figure 5: Test points

7.1 Background information

The REF2500 contains an internal sine wave generator with a reference accelerometer in the control loop to maintain a continuous output level of 1 g in either peak or RMS. The reference accelerometer’s signal is fed through a charge amplifier to the control electronics.

Proper operation of the feedback control loop and accuracy of the internal voltage reference can be verified by monitoring the voltage at the test point output. Since we are observing the accelerometer signal, the test points will also provide information as to any mechanical or significant electrical anomalies. In the event the REF2500 is dropped or otherwise abused, measuring the output from the test points will confirm if the unit is still operational.



7.2 Recommended instrumentation set-up

A digital multimeter (DMM) can be used to measure the signal amplitude. The DMM should be a high quality unit that has a current calibration certificate to ensure measurement accuracy. Figure 6 shows the attachment of a probe and clip lead going to a DMM.



Figure 6: Probe connected to the test point pins

An oscilloscope will provide information as to the shaker's wave shape. The test point output should be a sine wave with low distortion (less than 7%), as shown in Figure 7a. Excessive distortion or high levels of noise (Figure 7b) indicates possible mechanical damage to the shaker mechanism. If high levels of distortion, an incorrect output level, or out-of-tolerance frequency is observed, the REF2500 should be returned to the factory for service. There are no user-serviceable parts in the unit.

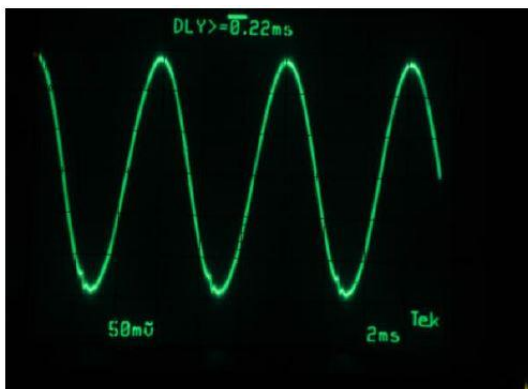

Figure 7a: Acceptable sine wave from ReferenceMate

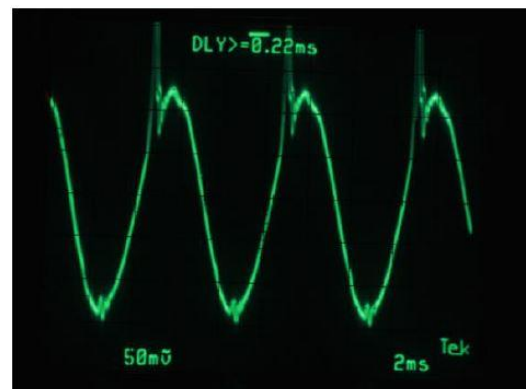

Figure 7b: Example of unacceptable noise

The table below shows the expected test point output voltage amplitudes. The amplitude depends on the peak/RMS setting, as shown. Measured values should be within $\pm 3.0\%$ of those specified.

Table 4: Test output voltages

Setting	RMS value	Peak value	Peak to Peak value
RMS	100 mV	141 mV	282 mV
Peak	70.7 mV	100 mV	200 mV

A frequency counter may also be used to confirm the frequency of the excitation signal. The frequency should be within $\pm 1.5\%$ of the selected frequency.



7.3 Protection from the environment

The ReferenceMate meets Ingress Protection Rating IP54 for dust and water resistance. The unit is O-ring sealed to be resistant to dirt, dust and moisture encountered during normal operation. Although moisture resistant, the unit is NOT submersible.



CAUTION: To meet the IP54 rating, both the battery cap and DC power jack cover must be securely installed on the unit. Do not expose the unit to dust or moisture without both of these protective mechanisms in place.

8.0 Storage

If the unit is going to be out of service for an extended period of time, store in a dry controlled environment. Remove the batteries to prevent possible damage caused by the leakage of battery fluids. Storage temperature range is -40°C (-40°F) to 85°C (185°F).

9.0 Technical assistance and customer service

For technical assistance and all customer service inquiries, please contact info@wilcoxon.com or by phone at +1 (301) 330-8811.

X-ON Electronics

Largest Supplier of Electrical and Electronic Components

Click to view similar products for [Calibration Equipment](#) category:

Click to view products by [Amphenol](#) manufacturer:

Other Similar products are found below :

[700P27](#) [AX-C830](#) [AKT7113100](#) [AKT8R112100](#) [AKT4R1121001](#) [AKT4R1122001](#) [AR604/P](#) [461750](#) [AX-C850](#) [RT-820](#) [FLUKE 709](#)
[FLUKE-805](#) [AKT4R111100](#) [AKT4R111200](#) [AKT4R112100](#) [AKT7111100J](#) [AKT7211100J](#) [AKT7212100J](#) [AKT8R111100](#) [REF2510R](#)
[K39-LCRR](#) [412355A](#) [461831](#) [461895](#) [461920](#) [480400](#) [480403](#) [PRC15](#) [PRC30](#) [700P02](#) [700P27EX](#) [700P29](#) [FLUKE-705](#) [FLUKE 707](#)
[FLUKE-714B/EN](#) [FLUKE-715](#) [FLUKE BP7235](#) [K3MA-J-A2](#) [24VAC/DC](#) [U086](#) [U087](#) [03K30R-MSOTS3](#) [19CK010-150](#) [P5514-70M](#)
[P5515-140M](#) [12890](#) [TACH-10](#) [461950](#) [461825](#) [461830](#) [461891](#)