

Amphenol SOCAPEX

MIL-DTL-38999 Series & Derivatives



www.amphenol-socapex.com

TABLE OF CONTENT



About Amphenol Socapex	4
Markets and applications	8
Quick selection guide	10
Quick reference	12
TECHNICAL CHARACTERISTICS	16
Contacts arrangements	18
Keyway position - Connectors Polarization	28
Panel hole dimensions	29
PCB Contacts patterns - PCB Drillings	32
MIL-DTL-38999 SERIES III & EN3645, TV / CTV	51
STANDARD RANGE - TV / CTV Series	52
General characteristics	52
Mechanical characteristics	53
Environmental characteristics	54
Electrical characteristics	55
Metal shells - TV Series (MIL-DTL-38999/20/24/26 - EN3645)	56
Composite shells - CTV Series (MIL-DTL-38999/20/24/26 - EN3645)	67
Metal & Composite shells weights (MIL-DTL-38999/20/24/26 - EN3645)	64
Hermetic receptacles (MIL-DTL-38999/21/23/25) 	68
Lanyard release plugs (MIL-DTL-38999/29/30/31) 	71
EXTENDED RANGE	77
Connectors with integrated backshells - F472	78
Square flange receptacles equipped with clinch nuts - F506	83
Stand-off Double flange receptacles - F459	85
Reduced flange receptacles - F312 & F059	87
Enhanced sealing receptacles - ETC ETCI ETLI	91
Thru-bulkhead receptacles - TVB	93
DERIVED RANGE	97
387TV - Size 7 shell	98
PowerSafe - VG96944 - Power with User safety	112
RNJ LP - Rack and panel	126
SC39 - Quick disconnection	134
TVμCOM - 10GB+	142
TVOP	148
StartOP	148

TABLE OF CONTENT

MIL-DTL-38999 SERIES II, JT	151
STANDARD RANGE - JT SERIES	152
General characteristics	152
Technical characteristics	153
Electrical characteristics	154
JT Series (MS27***)	157
EXTENDED RANGE	161
Stand-Off receptacle - F459	161
Integrated backshell - F472	163
DERIVED RANGE	164
SC39 LP - Breakaway Low Profile connector	164
MIL-DTL-38999 Series I, LJT	169
STANDARD RANGE - LJT SERIES	170
General characteristics	170
Technical characteristics	171
Electrical characteristics	172
LJT Series (MS27***, HE308)	175
EXTENDED RANGE	179
Stand-Off receptacle - F459	179
Integrated backshell - F472	180
Enhanced sealing receptacle - ETC ETCI ETLI	181
Thru-bulkhead receptacle (JMS/HE308)	183
DERIVED RANGE	185
RNJ - Rack and panel (HE308)	185
OPTICAL FIBER	198
LJT OP	198
RNJ OP - Rack and panel	201
ACCESSORIES & TOOLS	205
BACKSHELLS QUICK SELECTION GUIDE	206
PROTECTIVE CAPS	207
Standard metal cap	207
Rubber cap	211
Self-closing cap	213
Plastic dust cap	215
Stopper for panels	216
OTHERS ACCESSORIES	217
Dummy receptacles	217
Holding support	218
Panel gasket for Square flange receptacles	217
CONTACT ASSEMBLY INSTRUCTIONS	219
Wire stripping, contact crimping, contact insertion & removal	219
Part numbering - Contacts, tooling & accessories	221

OUR COMPANY



Proven excellence in interconnect solutions

- Since **1947**, Amphenol Socapex has prescribed, designed and manufactured reliable and innovative interconnection solutions for harsh environments, specializing in standard and customized electrical and fiber optic connectors, contacts, accessories and cabling solutions.
- Located in the **Mont Blanc region** of France and Pune in India, Amphenol Socapex serve customers in over 100 countries around the world.
- Amphenol Socapex is part of the leading supplier of interconnect systems **Amphenol**.



1400+
employees



142 M€
Net Sales 2023
70% Export - 30% France



Thyez, **France**
Pune, **India**



Our expertise has no boundaries

Integrated Production in France & India

- 24 000 m² manufacturing capacity on 2 sites
- Design and manufacturing centers in France and India
- State-of-the-art manufacturing technology

Our markets



Defense



**Commercial
Aerospace**



Space



Industry

TECHNOLOGIES & INNOVATION

Engineering Laboratory



Product testing and qualification expertise in many fields:

- Environmental, mechanical, electrical, chemical, climatic skills
- RF and fiber optics expertise

High-Speed Expertise



Strong expertise in high-speed signals

- 3D EM simulation software & EM models
- Time Domain and frequency domain

Materials Expertise



Focus on materials expertise and manufacturing techniques to produce faster, smaller and stronger products

- Advanced technology research and development: polymers, metals, platings, resins ...
- Cutting edge characterizations of interconnects: Radio Frequency, partial discharges ...
- 3D CAD mechanical software, simulation & analysis

Eco-responsibility



Sustainable environment approach, with pro-active management of regulations (REACH / RoHS / Conflict minerals...)

- New materials development, plating, and suitable processes
- Recycling and rational resources consumption

Our workshops



Our workshops located in France & India provide consistent quality adapted to your volume requirements.

Automation & Tooling : Tools for our different activities : molding, machining, assembly

Molding : Solid expertise in thermoplastic elastomer and thermoset molding

Machining : Manufacturing of cylindrical shells and rectangular shells

Screw Machining : Manufacturing of electrical contacts

Plating : Plating with cadmium, nickel, electroless nickel, silver, black zinc nickel, gold

Assembly : Connector and harness assembly (electrical & optical)

Our certifications

Product certifications : MIL-DTL38999, EN3645, EN3155, VG (VG95328, VG95319, VG96944, VG95218, VG96949)



Certified Management System



Certified Management System



Certified Management System



Certified Management System

Our memberships

Member of CMG (Connecting Manufacturing Group) Consortium



CUSTOMER EXPERIENCE



► We have a strong reputation for helping customers solve their toughest challenges. This approach of serving your needs is ingrained in our company - from our sales team to our product development engineers.

A partner you can trust

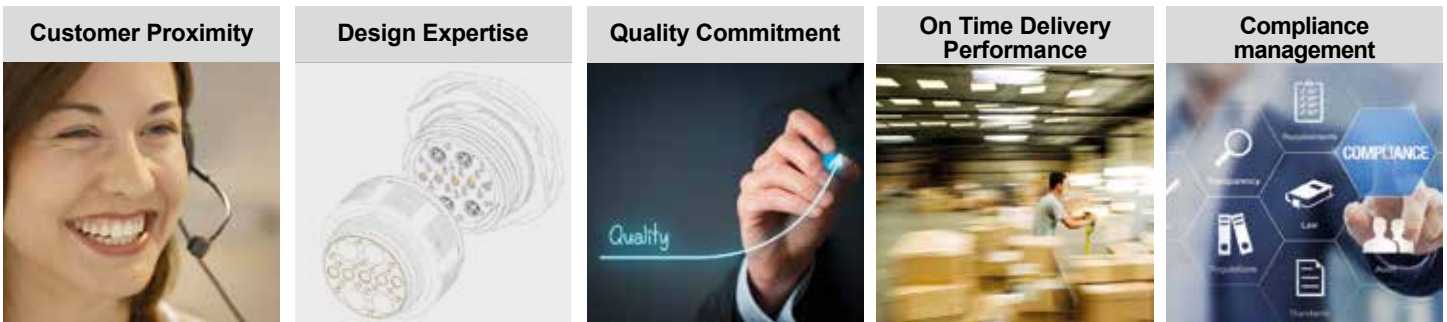

Buy our solutions

You can access our solutions through our global network of sales offices or through our distributors.

Field Sales Team :

- 10 in France
- 15 in Europe
- 100+ in North America and rest of the world.
- 5 Business Development Managers supporting local sales force Europe, North America and the rest of the world

- Technical Advisement & Multilingual Customer Service :**
20 people



Worldwide Distribution Network :

Our range of circular connectors, contacts, fiber optic connectors, PCB connectors and accessories are available thru our extensive distribution network.

It includes qualified distributors (QPL approved) for assembling MIL-DTL-38999 & derivatives and PT/451 (VG95328) connectors.

[Check our product inventory](#)



[Product Selectors & 3D Files](#)



NEW



OUR HISTORY

1947



- Socapex creation in Suresnes, France
- 1st radio connector

1956-57



- Manufacturing unit in Cluses (74), France
- Thomson-CSF becomes primary shareholder

Early 1960's



- 1st board level connectors: HE8
- 1st "licence Bendix" manufactured connectors
- SL Series

1973



- New factory in Thyez (74) France with 250 people, 13 000m²

1975



- Production of 38999 connectors

1986

Amphenol
Socapex

- Amphenol becomes primary shareholder

1995-96



- Expanded Beam connector
- CTOS launch
- Headquarters transferred to Thyez

2004



- RJ Field launch, "Award Electronica"

2005



- New factory in Pune, India

2010's



- LuxBeam™ and HDAS launch

2014-2017



- New workshops : Cable Assembly & Contact Manufacturing workshop

2019



- Increased manufacturing capacity with 2nd building in Pune, India

2022



- Harness in the box solution launch

Today & tomorrow



- New technologies : Investment in automation & technical expertise



- Amphenol SOCAPEX joins the "Convention des Entreprises pour le Climat".
- Our goal: to accelerate our transition to a more sustainable operation.

MARKETS AND APPLICATIONS



Military vehicles

Ground radios shelters
Ground vehicles
Battlefield
Communication systems



C5ISR

Threat detection system
Soldier wearable equipment
Rugged computer & digital radio
Satellite reception unit



Military Avionics & Airframe

Power unit
Aircraft
Radar
Display unit
Flight control system



Commercial Avionics & Airframe

Landing gear
Cockpit
Ground power supply
Engine Flowmeter



Missiles & UAVS

Air missiles and UAVS
Ground control station & launchers



Navy

Navigation guidance



Space

Launchers
Spacecraft
Ground Station
Rockets



Industrial

Automation
Transportation
Nuclear power station
Robotics



QUICK SELECTION GUIDE

Thanks to a high level of expertise on MIL-DTL-38999 SERIES I, II & III & EN3645 connectors, Amphenol Socapex is able to offer qualified connectors along with proprietary ones, and derivatives ranges to fit any customers needs.

STANDARD RANGE MIL-DTL-38999

	LJT 38999 Series I / HE308 <i>page 170</i> 	JT 38999 Series II <i>page 152</i> 	TV 38999 Series III / EN3645 <i>page 52</i> 	CTV 38999 Series III / EN3645 <i>page 52</i> 
STANDARD	38999 SERIES I / HE308	38999 SERIES II	D38999 / EN3645	D38999 / EN3645
DESCRIPTION	Metal cylindrical connector, Bayonet style	Metal cylindrical connector, Low Profile Bayonet Style	Metal cylindrical connector, Tri-start thread	Composite cylindrical connector, tri-start thread
MATERIALS	Aluminum	Aluminum	Aluminum Stainless steel Marine bronze	Composite
PLATINGS	- Olive drab cadmium - Black zinc nickel ✓ (REACH version available) - Nickel ✓	- Olive drab cadmium - Black Zinc Nickel ✓ - Nickel ✓	- Olive drab cadmium (Aluminum) ✓ - Black zinc nickel (Aluminum) ✓ - Tin Zinc (Aluminum) ✓ - Durmalon (Aluminum) ✓ - Nickel (Aluminum & S.Steel) ✓ - Passivated (S. Steel only) ✓	- Olive drab cadmium - Nickel
RECEPTACLE SHELL	Jam nut Square flange - Wall mount (Back & front panel mounting) In-line	Jam nut Square flange - Wall mount & Box mount (back & front panel mounting) In-line	Jam nut Square flange - Wall mount Square flange - Box mount In-line	Jam nut Square flange - Wall mount
GROUND PLANE OPTION AVAILABLE	Upon request	Upon request	G	G
FEED THROUGH PANEL	Thru bulkhead receptacle		Thru bulkhead receptacle	
EXTRA SEALING	- Enhanced sealing receptacle (<1.10 ⁻⁶ cm ³ /s) upon request - Hermetic receptacle (<1.10 ⁻⁷ cm ³ /s)	- Hermetic receptacle (<1.10 ⁻⁷ cm ³ /s)	- Enhanced sealing receptacle (<1.10 ⁻⁶ cm ³ /s) upon request - Hermetic receptacle (<1.10 ⁻⁷ cm ³ /s)	
LANYARD			Plug (D38999/29/30/31)	
INTEGRATED BACKSHELL OPTION (F472)	Plug & receptacle	Plug & receptacle	Plug & receptacle	
STAND-OFF OPTION DOUBLE FLANGE (F459)	Receptacle	Receptacle	Receptacle	
REDUCED FLANGE OPTION (F312)	Jam nut receptacle		Jam nut receptacle	
OPTICAL CONTACTS COMPATIBILITY	LJTOP, Luxbeam		STARTOP, TVOP, Luxbeam	Luxbeam
SIZES	09 to 25	08 to 24	09 to 25 / A to J	09 to 25 / A to J
CONTACTS ARRANGEMENTS	MIL-DTL-38999 series I, HE308	MIL-DTL-38999 series II	MIL-DTL-38999 series III, EN3645 & Proprietary layouts	MIL-DTL-38999 series III, EN3645 & Proprietary layouts

SHELL STYLES

PLUG



STRAIGHT

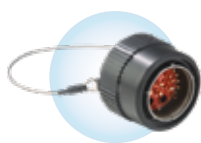

LANYARD RELEASE



JAM NUT



IN-LINE

RECEPTACLE



SQUARE FLANGE WALL MOUNT

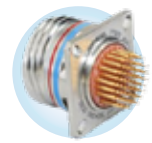

SQUARE FLANGE BOX MOUNT

G Ground plane proprietary option available (metal insert for use with Coaxial, Twinax, Quadrax or Octomax contacts)

QUICK SELECTION GUIDE

DERIVED RANGE - 38999 STYLE

387TV Size 7 shell page 98	POWERSAFE Power & User safety page 112	RNJ Rack & Panel page 185	RNJ LP Rack & Panel page 126	SC39 & SC39LP Quick Disconnect page 134
				
	VG96944	HE308		
Miniaturized circular connector (Size 7 shell)	High-power, 500V voltage with user safety	Blind mate connector with realignment and floatability	Blind mate connector with shorter distance between panels	Quick release / Breakaway connector
Aluminum	Aluminum Stainless steel Marine bronze	Aluminum Stainless steel	Aluminum Stainless steel	Aluminum Stainless steel
- Olive drab cadmium ✓ - Nickel ✓ - Black zinc nickel ✓	- Olive drab cadmium ✓ - Black zinc nickel ✓ - Tin Zinc ✓ - Nickel ✓ - Passivated (S. Steel) ✓	- Olive drab cadmium ✓ - Nickel ✓ - Black zinc nickel ✓ - Passivated (S. Steel) ✓	- Olive drab cadmium ✓ - Nickel (Aluminum & S. Steel) ✓ - Black zinc nickel ✓ - Passivated (S. Steel) ✓	- Olive drab cadmium ✓ - Nickel ✓ - Passivated (S. Steel) ✓
Jam nut Oval flange	Jam nut Square flange Wall mount	Jam nut Square flange Wall mount	Jam nut Square flange Wall mount	Jam nut Square flange Wall mount In-line
6 - 07-05 only		Consult us	Consult us	Consult us
Enhanced sealing (<math><1.10^{-6}</math>cm ³ /s) Upon request		Enhanced sealing (<math><1.10^{-6}</math>cm ³ /s) Upon request	Enhanced sealing (<math><1.10^{-6}</math>cm ³ /s) Upon request	Enhanced sealing (<math><1.10^{-6}</math>cm ³ /s) Upon request
				Lanyard plug Lanyard In-line receptacle
Always included except for PC tails		Upon request	Upon request	Plug & receptacle
Only available in Reduced flange		Receptacle	Receptacle	Receptacle
Jam nut receptacle	Jam nut receptacle	Jam nut receptacle & plug		
Butt joint / Expanded Beam		RNJ OP	Upon request	
07	13, 15, 17, 21, 23, 25	11 to 25	11 to 25	[Depending on shell style] 09 to 17 / 08 to 14
07-05 07-09 07-12	07-35 07-98	13-E4, 15-E4, 17-E6, 21-E4, 23-E4, 25-E6 VG insert available	Series I (HE308) Series III	Series III (SC39) Series II (SC39 LP)

EXTENDED RANGE



STAND-OFF DOUBLE-FLANGE



REDUCED FLANGE



REDUCED FLANGE STAND-OFF



CLINCH NUTS



INTEGRATED BACKSHELL



OVAL FLANGE ▲
▲ 387TV Only

MATERIALS & PLATINGS

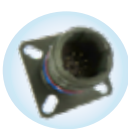

ALUMINUM

- Olive drab cadmium
- Electroless Nickel ✓
- Black zinc nickel ✓
- Reach version available
- Tin Zinc ✓
- Durmalon (Nickel PTFE) ✓



COMPOSITE

- Olive drab cadmium
- Electroless Nickel ✓



STAINLESS STEEL

- Passivated ✓
- Nickel ✓

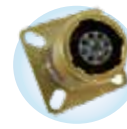

MARINE BRONZE

- Without plating ✓

✓ : RoHS compliant

QUICK REFERENCE GUIDE



MIL-DTL-38999 Series III, EN3645, TV & CTV - STANDARD RANGE

Metal shells - TV Series (MIL-DTL-38999/20/24/26 - EN3645)

- Large choice of materials and platings.
- Complete range of contact arrangements.
- Suitable for C5ISR, Navy, Armored vehicles, Military aircraft and Missiles.



Composite shells - CTV Series (MIL-DTL-38999/20/24/26 - EN3645)

- Up to 70% weight saving compare to a Stainless Steel version.
- Complete range of composite connectors and backshells.
- Suitable for Commercial and Military aircrafts.



Hermetic receptacles (MIL-DTL-38999/21/23/25)

- Air leakage limited to 1.10^{-7} cm³/s.
- Glass sealed insert technology.
- TVSY & TVSYN, D38999/21/23/25.



Lanyard release plug (MIL-DTL-38999/29/30/31)

- Instant disengagement.
- Quick disconnect with an axial pull of lanyard or normal rotation of the coupling ring.
- D38999/29/30/31.

MIL-DTL-38999 Series III, EN3645, TV & CTV - EXTENDED RANGE

Plugs and receptacles with integrated backshells

- Suitable for MIL-DTL-38999 Series III plugs and receptacles.
- All-in-one connector.
- 50% length and weight saving on average compare to a TV connector with TV35 backshell.



Square flange receptacles equipped with clinch nuts

- Derived from MIL-DTL-38999 Series III Square flange receptacles.
- Self locking system.
- Time saving during installation.

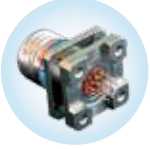

Stand-Off - Double flange receptacles

- Derived from MIL-DTL-38999 Series III receptacles with PC Tail contacts.
- Double flange to avoid stress on contact terminations.
- Grounding continuity between the PCB and the appliance.



Reduced flange receptacles

- Derived from MIL-DTL-38999 Series III Jam nut receptacles.
- 41% footprint reduction & 20% weight saving on average.
- Mates with standard MIL-DTL-38999 Series III plugs.
- Available in standard & Stand-off versions



Enhanced sealing receptacles

- Air leakage limited to 1.10^{-6} cm³/s.
- Intermateable with MIL-DTL-38999 Series III plugs.
- Dedicated to applications requiring low air leakage.



Thru-bulkhead receptacles

- Intermateable with MIL-DTL-38999 Series III plugs.
- Use to link two plugs through a panel.
- 6 polarization possibilities.

QUICK REFERENCE GUIDE



MIL-DTL-38999 Series III, EN3645, TV & CTV - DERIVED RANGE

387TV - Size 7 shell

- Derived from MIL-DTL-38999 Series III connectors - The smallest connector size around 38999 series III type contacts
- Available with Signals (from 9 to 1 contacts) & Grounded versions for Coax, Twinax, Quadrx, Octomax
- Fiber optics version available soon
- Integrated backshell included, except for PC Tails.



Powersafe - Power with user safety

- Qualified VG96944-04 (for Aluminum & Marine bronze versions).
- Derived from MIL-DTL-38999 Series III connectors.
- Connector dedicated to high power (up to 500V), focusing on user safety

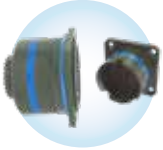

RNJ LP - Rack and Panel Low Profile

- Rack and Panel connectors derived from MIL-DTL-38999 Series III.
- Dedicated to blind mate connections.
- Realignment on 3 axis: axial, angular and longitudinal.



SC39 - Quick disconnection

- Quick release/Breakaway connectors.
- Derived from MIL-DTL-38999 Series III.
- Full range available: lanyard, stand-off receptacles, integrated backshells ...



TVμCOM - 10Gb+

- Based on MIL-DTL-38999 Series III – Shell size 11.
- 10Gb+: exceeds 10Gb/s Ethernet following IEEE 802.3an-2006: 10GBase-T.
- Cat.6A connector according to TIA568C.2 and ISO/IEC11801 standard.



TVOP & STARTOP - Optical fiber

- Multichannel butt joint optical connector.
- Available in multimode and singlemode.
- High performance and reliability for outdoor and indoor solutions.



MIL-DTL-38999 Series II, JT - STANDARD RANGE

Metal shells - JT series (MIL-DTL-38999 II)

- Bayonet coupling connectors.
- Low profile and light weight connectors.
- Large variety of contact arrangements and shell styles.



MIL-DTL-38999 Series II, JT - DERIVED RANGE

SC39LP - Quick Disconnection Low Profile

- Quick release/Breakaway connectors.
- Derived from MIL-DTL-38999 Series II.
- Low profile: lighter & shorter connectors.

QUICK REFERENCE GUIDE



MIL-DTL-38999 Series I, HE308 & LJT - STANDARD RANGE

Metal shells - LJT Series (MIL-DTL-38999 Series I - HE308)

- Bayonet coupling connectors.
- 100% scoop-proof.
- Large choice of materials, platings & contact arrangements.



MIL-DTL-38999 Series I, HE308 & LJT - EXTENDED RANGE

Stand-off receptacles

- Derived from MIL-DTL-38999 Series I receptacles with PC-tail contacts.
- Double flange to avoid stress on contact termination.
- Grounding continuity between the PCB and the appliance.



Thru-bulkhead receptacles (HE308)

- Intermateable with MIL-DTL-38999 Series I plugs.
- Certified HE308.
- Used to link two plugs through a panel.
- HE3080BT / LJTB



MIL-DTL-38999 Series I, HE308 & LJT - DERIVED RANGE

RNJ - Rack and Panel (HE308)

- Rack and panel connector derived from MIL-DTL-38999 Series I.
- Dedicated to blind mate connections.
- Realignment on 3 axis: axial, angular and longitudinal.



LJTOP & RNJOP - Optical fiber

- MIL-DTL-38999 Series I with optical termini. (LJTOP)
- Rack and panel version available. (RNJOP)
- Available in multimode and singlemode.
- High performance and reliability for outdoor and indoor solutions.



ACCESSORIES & TOOLS

Backshells / AS85049 & proprietary

- Complete range of backshells for any needs and applications.
- Available versions: shielding, sealing, mechanical retention...
- Functions: EMI/RFI, environmental backshells...



Protective caps / Mil-spec & proprietary

- Standard metal caps (EMI, complete range of platings and lanyards) for plugs and receptacles.
- Metal self-closing caps (EMI, complete range of platings) for receptacles.
- Silicone caps with nylon cord for any receptacles and plugs.
- Plastic dust caps.



Other accessories

- Dummy receptacle, holding support, Stopper for Jam nut receptacle panel's hole.

Application tools

- Crimping tool, Contacts insertion & removal tools.

TECHNICAL CHARACTERISTICS - ALL RANGES



Table of contents

TECHNICAL CHARACTERISTICS	
Contacts arrangements table	18
Contacts arrangements	20
Keyway position - Connectors Polarization	28
Panel Hole dimensions	29
PCB contacts - Lengths & hole dimensions	31
PCB contacts patterns - PCB Drillings	34

THE STANDARD RANGES SERVES VARIOUS MARKETS, INCLUDING:



Commercial Avionics & Airframe



Military Avionics & Airframe



Military vehicles



C4ISR



Missiles



Navy



Industrial

CONTACTS ARRANGEMENTS

As stated in MIL-DTL-38999 standard, insert arrangements using multi-axial contacts (Coax, Twinax, Quadrax...) should not be used in firewall applications.

MIL-DTL-38999 ^{HD} arrangements and EN3645 Quadrax and/or grounded arrangements are given for information only. Not qualified. Amphenol designation only.

^{HD} Quadrax & differential Twinax arrangements are not rated over 175°C.

Series				Contacts size											Ground plane option	Quadrax Option	Firewall available	Hermetic available	
Amphenol	Military	ASD-STAN	Service rating	Nb of contacts	23 ^{HD}	22D	20	16	12	12 Coax	8 Power	8 Coax	8 Twinax	4 Power					
TV CTV	JT	LJT	D38999	EN3645 (wo Quadrax)															
9-05 Grounded only					G	1								1 Δ		G	Q	F	Y
9-09 ^{HD}			A23		N	9	9									G			
9-12					M	1				1						G			
9-35	8-35	9-35	A35	AN35	M	6	6											F	Y
9-94					M	2													
9-98	8-98	9-98	A98	AN98	I	3												F	Y
11-01					I	1								1 □		G	Q		
11-02		11-02	B2		I	2										G		F	
11-04		11-04		BN04	I	4												F	
11-05	10-05	11-05	B5	BN05	I	5												F	TV
11-12		11-12			II	1								1		G			
11-19 ^{HD}			B23		N	19	19												
11-35	10-35	11-35	B35	BN35	M	13	13											F	Y
11-98	10-98	11-98	B98	BN98	I	6												F	Y
11-99	10-99	11-99	B99	BN99	I	7												F	TV
13-04	12-04	13-04	C4		I	4										G		F	Y
13-08	12-08	13-08	C8	CN08	I	8												F	Y
13-26		13-26			M	8								2					
13-32 ^{HD}			C23		N	32	32												
13-35	12-35	13-35	C35	CN35	M	22												F	Y
13-98	12-98	13-98	C98	CN98	I	10												F	Y
15-04	14-04	15-04			I	4								4		G			
15-05	14-05	15-05	D5		II	5								5		G		F	Y
15-15	14-15	15-15	D15		I	15								14	1			F	Y
15-18	14-18	15-18	D18	DN18	I	18								18				F	Y
15-19	14-19	15-19	D19	DN19	I	19								19				F	Y
15-BA					M	25								22	3				
15-35	14-35	15-35	D35	DN35	M	37								37				F	Y
15-55 ^{HD}			D23		N	55	55												
15-97	14-97	15-97	D97		I	12								8	4			F	Y
17-EL					M	19								16				Q	
17-02 / 17-03		17-02	E2 / E3		M	39								38				Q	
17-06	16-06	17-06	E6		I	6								6				F	Y
17-08	16-08	17-08	E8	EN08	II	8								8				F	Y
17-20					M	20								16					
17-22					M	4												Q	
17-25		17-25			M	24								22					
17-26	16-26	17-26	E26	EN26	I	26								26				F	Y
17-35	16-35	17-35	E35	EN35	M	55								55				F	Y
17-73 ^{HD}			E23		N	73	73												
17-75		17-75		EN75	M	2												Q	
17-99	16-99	17-99	E99		I	23								21	2			F	Y
19-A4					M	4												Q	
19-11	18-11	19-11	F11		II	11								11				F	Y
19-17				FN17 (Alu & Comp)	M	17								10	1	4		Q	
19-18 / 19-19		19-18	F18 / F19		M	18								14				Q	
19-28	18-28	19-28	F28		I	28								26	2			F	
19-30	18-30				I	30								29	1				
19-31					M	15								12				Q	
19-32	18-32	19-32	F32	FN32	I	32								32				F	Y
19-35	18-35	19-35	F35	FN35	M	66								66				F	Y
19-88 ^{HD}					N	88	88												
21-11		21-11	G11	GN11	I	11												F	Y
21-16	20-16	21-16	G16	GN16	II	16												F	Y
21-AJ / 21-20				GN20	M	20												Q	
21-29			G29		I	27								18				F	
21-35	20-35	21-35	G35	GN35	M	79								79				F	Y
21-39	20-39	21-39	G39		I	39								37	2			F	Y
21-41	20-41	21-41	G41	GN41	I	41								41				F	Y

CONTACTS ARRANGEMENTS

As stated in MIL-DTL-38999 standard, insert arrangements using multi-axial contacts (Coax. Twinax. Quadrax...) should not be used in firewall applications.

MIL-DTL-38999 **HD** arrangements and EN3645 Quadrax and/or grounded arrangements are given for information only. Not qualified. **Amphenol designation only.**

HD, Quadrax & differential Twinax arrangements are **not rated over 175°C**.

●	○	⊖	⊕	⊗	⊙	⊘	⊚	⊛	⊜	⊝	⊞	⊟	⊠	⊡	⊢	⊣	⊤	⊥	⊦	⊧	⊨	⊩	⊪	⊫	⊬	⊭	⊮	⊯	⊰	⊱	⊲	⊳	⊴	⊵	⊶	⊷	⊸	⊹	⊺	⊻	⊼	⊽	⊾	⊿
23	22D	20	16	12	8	4	00	0000	High density	Ground plane version available	Quadrax available	Hermetic available	Lanyard release plug available	Coax or Twinax	Differential Twinax or Quadrax	Power contacts																												

Front face of pin insert shown, master keyway illustrated.



Grounded version only

Series III/TV-CTV
Series II/JT
Series I/LJT (HE308)
MIL-DTL-38999 Series III
EN3645
Total contacts
Contact size

07-05 / 09-05
AG01/AQ01
1
8 TwinaxΔ



07-09 / 09-09
A23
9
23



07-12 / 09-12
/
1
12



07-35 / 09-35
08-35
09-35 (09-35)
A35
AN35
6
22D



Series III/TV-CTV
Series II/JT
Series I/LJT (HE308)
MIL-DTL-38999 Series III
EN3645
Total contacts
Contact size

07-94 / 09-94
/
2
20



07-98 / 09-98
08-98
09-98 (09-98)
A98
AN98
3
20



Series III/TV-CTV
Series II/JT
Series I/LJT (HE308)
MIL-DTL-38999 Series III
EN3645
Total contacts
Contact size

11-01
/
1
8 Twinax□



11-02
11-02
B2
2
16



11-04
11-04
BN04
4
20

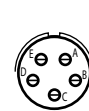

11-05
10-05
11-05
B5
BN05
5
20

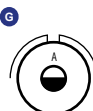

Series III/TV-CTV
Series II/JT
Series I/LJT (HE308)
MIL-DTL-38999 Series III
EN3645
Total contacts
Contact size

11-12
11-12 (11-01)
1
12



11-19
/
19
23



11-35
10-35
11-35 (11-35)
B35
BN35
13
22D



11-98
10-98
11-98 (11-98)
B98
BN98
6
20

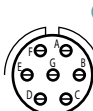

Series III/TV-CTV
Series II/JT
Series I/LJT (HE308)
MIL-DTL-38999 Series III
EN3645
Total contacts
Contact size

11-99
10-99
11-99
B99
BN99
7
20

- Δ Delivered with Twinax contacts for simple braid cable (M17/1760002. AECMA Pr EN3375-003. Raychem 10612. EPD44690. EPD44691)
- Delivered with Twinax contacts for double braid cable (PAN 6421. AECMA Pr EN 3375 - 004. Raychem 10613. EPD44692. EPD44693)
- / Not applicable

CONTACTS ARRANGEMENTS

As stated in MIL-DTL-38999 standard, insert arrangements using multi-axial contacts (Coax, Twinax, Quadrax...) should not be used in firewall applications.

MIL-DTL-38999 **HD** arrangements and EN3645 Quadrax and/or grounded arrangements are given for information only. Not qualified. Amphenol designation only.

HD, Quadrax & differential Twinax arrangements are **not rated over 175°C**.

●	○	⊖	⊕	⊗	⊙	⊘	⊚	⊛	⊜	⊝	⊞	⊟	⊠	⊡	⊢	⊣	⊤	⊥	⊦	⊧	⊨	⊩	⊪	⊫	⊬	⊭	⊮	⊯	⊰	⊱	⊲	⊳	⊴	⊵	⊶	⊷	⊸	⊹	⊺	⊻	⊼	⊽	⊾	⊿
23	22D	20	16	12	8	4	00	0000	High density	Ground plane version available	Quadrax available	Hermetic available	Lanyard release plug available	Coax or Twinax	Differential Twinax or Quadrax	Power contacts																												

Front face of pin insert shown, master keyway illustrated.

Series III/TV-CTV	13-04	13-08	13-26	13-32	
Series II/JT	12-04	12-08	/	/	
Series III/JT (HE308)	13-04	13-08	13-26	/	
MIL-DTL-38999 Series III	C4	C8	/	C23	
EN3645	/	CN08	/	/	
Total contacts	4	8	6 / 2	32	
Contact size	16	20	22D / 12	23	
Series III/TV-CTV	13-35	13-98			
Series II/JT	12-35	12-98			
Series III/JT (HE308)	13-35 (13-35)	13-98 (13-98)			
MIL-DTL-38999 Series III	C35	C98			
EN3645	CN35	CN98			
Total contacts	22	10			
Contact size	22D	20			
Series III/TV-CTV	15-04	15-05	15-15	15-18	15-19
Series II/JT	14-04	14-05	14-15	14-18	14-19
Series III/JT (HE308)	15-04	15-05 (15-05)	15-15	15-18	15-19 (15-19)
MIL-DTL-38999 Series III	D5	D15	D18	D19	D19
EN3645	/	/	DN18	/	DN19
Total contacts	4	5	14 / 1	18	19
Contact size	12	16	20 / 16	20	20
Series III/TV-CTV	15-BA (15-25)	15-35	15-55	15-97	
Series II/JT	/	14-35	/	14-97	
Series III/JT (HE308)	/	15-35 (15-35)	/	15-97 (15-97)	
MIL-DTL-38999 Series III	/	D35	D23	D97	
EN3645	/	DN35	/	/	
Total contacts	22 / 3	37	55	8 / 4	
Contact size	22D / 16	22D	23	20 / 16	

/ Not applicable

CONTACTS ARRANGEMENTS

As stated in MIL-DTL-38999 standard, insert arrangements using multi-axial contacts (Coax, Twinax, Quadrax...) should not be used in firewall applications.

MIL-DTL-38999 **HD** arrangements and EN3645 Quadrax and/or grounded arrangements are given for information only. Not qualified. Amphenol designation only.

HD Quadrax & differential Twinax arrangements are **not rated over 175°C**.

	23	22D	20	16	12	8	4	00	0000	HD	G	Q	Y	L	Coax or Twinax	Differential Twinax or Quadrax	Power contacts
										High density	Ground plane version available	Quadrax available	Hermetic available	Lanyard release plug available	16, 12, 8		

Front face of pin insert shown, master keyway illustrated.

Series III/TV-CTV	17-EL	17-02 / 17-03 SB	17-06	17-08
Series III/JT			16-06	16-08
Series III/LJT (HE308)		17-02	17-06 (17-06)	17-08 (17-08)
MIL-DTL-38999 Series III		E2 / E3	E6	E8
EN3645				EN08
Total contacts	16	38	6	8
Contact size	22D 12 8 TwinaxΔ	22D 8 TwinaxΔ	12	16

16
17

Series III/TV-CTV	17-20	17-22	17-25	17-26
Series III/JT				16-26
Series III/LJT (HE308)	17-20		17-25	17-26 (17-26)
MIL-DTL-38999 Series III				E26
EN3645				EN26
Total contacts	16	2	22	26
Contact size	22D 12	12 Coax 8 Twinax□	22D 8 Coax	20

Series III/TV-CTV	17-35	17-73	17-75	17-99
Series III/JT	16-35			16-99
Series III/LJT (HE308)	17-35 (17-35)		17-75 (17-75)	17-99 (17-99)
MIL-DTL-38999 Series III	E35	E23	EN75	E99
EN3645	EN35			
Total contacts	55	73	2	21
Contact size	22D	23	8 TwinaxΔ	20 16

18
19

Series III/TV-CTV	19-A4	19-11	19-17	19-18 / 19-19 SB
Series III/JT		18-11		
Series III/LJT (HE308)		19-11 (19-11)		19-18
MIL-DTL-38999 Series III		F11	FN17 (alu & composite only)	F18 / F19
EN3645				
Total contacts	4	11	10 1 4 2	14 4
Contact size	8 TwinaxΔ	16	22D 20 16 8 Twinax□	22D 8 TwinaxΔ

- SB** 17-03 & 19-19 contacts arrangements are intended to be used with D38999/62 sealing boots to seal the size 8 contacts
- △ Delivered with Twinax contacts for simple braid cable (M17/1760002, AECMA Pr EN3375-003, Raychem 10612, EPD44690, EPD44691)
- Delivered with Twinax contacts for double braid cable (PAN 6421, AECMA Pr EN 3375 - 004, Raychem 10613, EPD44692, EPD44693)
- / Not applicable

CONTACTS ARRANGEMENTS

As stated in MIL-DTL-38999 standard, insert arrangements using multi-axial contacts (Coax, Twinax, Quadrax...) should not be used in firewall applications.

MIL-DTL-38999 **HD** arrangements and EN3645 Quadrax and/or grounded arrangements are given for information only. Not qualified. Amphenol designation only.

HD Quadrax & differential Twinax arrangements are **not rated over 175°C**.

●	○	⊖	⊕	⊗	⊙	⊘	⊚	⊛	⊜	⊝	⊞	⊟	⊠	⊡	⊢	⊣	⊤	⊥	⊦	⊧	⊨	⊩	⊪	⊫	⊬	⊭	⊮	⊯	⊰	⊱	⊲	⊳	⊴	⊵	⊶	⊷	⊸	⊹	⊺	⊻	⊼	⊽	⊾	⊿
23	22D	20	16	12	8	4	00	0000	High density	Ground plane version available	Quadrax available	Hermetic available	Lanyard release plug available	Coax or Twinax	Differential Twinax or Quadrax	Power contacts																												

Front face of pin insert shown, master keyway illustrated.

20
21

Series III/TV-CTV Series II/JT Series I/LJT (HE308) MIL-DTL-38999 Series III EN3645 Total contacts Contact size	21-42 / / / 2 4	21-72 / / / 6 2 16 4	21-75 / 21-76 ^{SB} / 21-75 (21-75) G75 / G76 ^o GN75 4 8 Coax ● or 8 Twinax△ 21-121 / G23 121 23

Series III/TV-CTV Series II/JT Series I/LJT (HE308) MIL-DTL-38999 Series III EN3645 Total contacts Contact size	23-P1 / 23-P1 (23-01) / 1 00 (2/0) Power	23-06 / / HN06 (alu & composite only) 6 8 Twinax△	23-14 / 22-14 / 14 12 23-21 / 22-21 / 23-21 (23-21) H21 21 16

Series III/TV-CTV Series II/JT Series I/LJT (HE308) MIL-DTL-38999 Series III EN3645 Total contacts Contact size	23-35 22-35 23-35 (23-35) H35 HN35 100 22D	23-53 / 23-53 (23-53) H53 HN53 53 20	23-54 / / 40 22D 9 16 4 12 23-55 22-55 23-55 H55 HN55 55 20

22
23

- ^{SB} 21-76 contacts arrangement is intended to be used with D38999/62 sealing boots to seal the size 8 contacts
- △ Delivered with Twinax contacts for simple braid cable (M17/1760002. AECMA Pr EN3375-003. Raychem 10612. EPD44690. EPD44691)
- Delivered with 4 Coaxial contacts for RG180 and RG195 wire under Amphenol designation
- ^o 21-75 / 21-76 is MIL-qualified with Twinax contacts only
- / Not applicable

CONTACTS ARRANGEMENTS

As stated in MIL-DTL-38999 standard, insert arrangements using multi-axial contacts (Coax. Twinax. Quadrax...) should not be used in firewall applications.

MIL-DTL-38999 **HD** arrangements and EN3645 Quadrax and/or grounded arrangements are given for information only. Not qualified. Amphenol designation only.

HD Quadrax & differential Twinax arrangements are **not rated over 175°C**.

●	◐	⊖	⊕	◑	●	○	⊗	⊙	HD	G	Q	Y	L	Coax or Twinax	Differential Twinax or Quadrax	Power contacts
23	22D	20	16	12	8	4	00	0000	High density	Ground plane version available	Quadrax available	Hermetic available	Lanyard release plug available	16, 12, 8	●	● ◐ ⊖ ⊕ ⊗ ⊙

Front face of pin insert shown, master keyway illustrated.

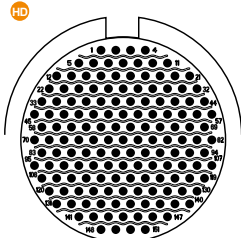

Series III/TV-CTV	23-151
Series II/JT	/
Series II/LJT (HE308)	/
MIL-DTL-38999 Series III	H23
EN3645	/
Total contacts	151
Contact size	23

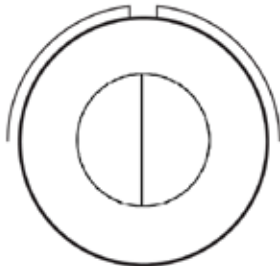

Series III/TV-CTV	25-P1
Series II/JT	/
Series II/LJT (HE308)	25-P1 (25-01)
MIL-DTL-38999 Series III	/
EN3645	/
Total contacts	1
Contact size	0000 (4/0) Power

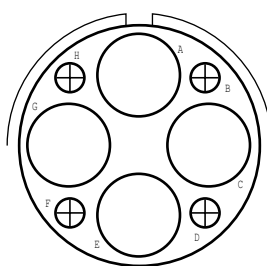

Series III/TV-CTV	25-1A
Series II/JT	/
Series II/LJT (HE308)	25-1A (25-44)
MIL-DTL-38999 Series III	/
EN3645	/
Total contacts	4
Contact size	16
	4 Power

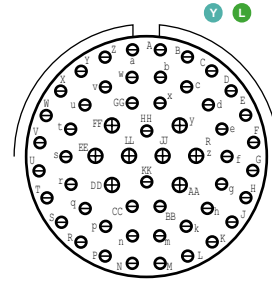

Series III/TV-CTV	25-04
Series II/JT	/
Series II/LJT (HE308)	24-04
MIL-DTL-38999 Series III	25-04
EN3645	/
Total contacts	48
Contact size	20
	8
	16
	J4
	JN04

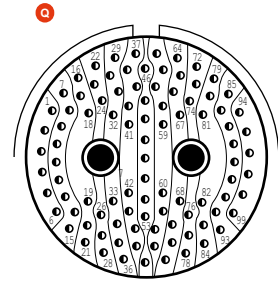

Series III/TV-CTV	25-07 / 25-09
Series II/JT	/
Series II/LJT (HE308)	25-07
MIL-DTL-38999 Series III	J7 / J9
EN3645	JN07
Total contacts	97
Contact size	22D
	2
	8 TwinaxΔ

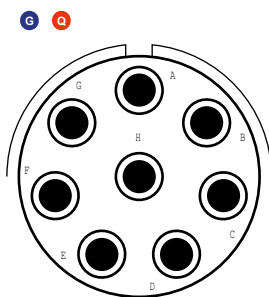

Series III/TV-CTV	25-08 / 25-10
Series II/JT	/
Series II/LJT (HE308)	/
MIL-DTL-38999 Series III	J8 / J10
EN3645	JN08
Total contacts	8
Contact size	8 Twinax□

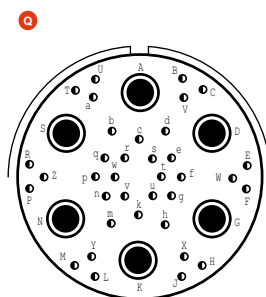

Series III/TV-CTV	25-17
Series II/JT	/
Series II/LJT (HE308)	/
MIL-DTL-38999 Series III	JN17
EN3645	/
Total contacts	36
Contact size	22D
	6
	8 TwinaxΔ

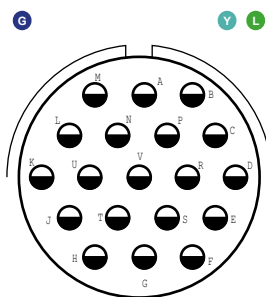

Series III/TV-CTV	25-19
Series II/JT	/
Series II/LJT (HE308)	24-19
MIL-DTL-38999 Series III	25-19
EN3645	/
Total contacts	19
Contact size	12

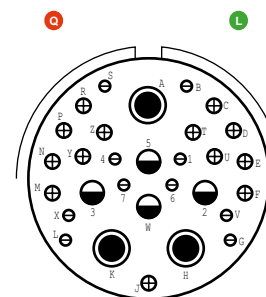

Series III/TV-CTV	25-20 / 25-21
Series II/JT	/
Series II/LJT (HE308)	/
MIL-DTL-38999 Series III	J20 / J21
EN3645	/
Total contacts	10
Contact size	13
	4
	3
	12 Coax
	8 TwinaxΔ

- SB 25-09, 25-10, 25-21 contacts arrangements are intended to be used with D38999/62 sealing boots to seal the size 8 contacts
- Δ Delivered with Twinax contacts for simple braid cable (M17/1760002. AECMA Pr EN3375-003. Raychem 10612. EPD44690. EPD44691)
- Delivered with Twinax contacts for double braid cable (PAN 6421. AECMA Pr EN 3375 - 004. Raychem 10613. EPD44692. EPD44693)
- ▲ Size 12 Coax : 2 contacts M39029/28-211 or M39029/75-416 for cavities 2 & 3 and 2 contacts M39029/102-558 or M39029/103-559 for cavities 5 & W
- / Not applicable

CONTACTS ARRANGEMENTS

As stated in MIL-DTL-38999 standard, insert arrangements using multi-axial contacts (Coax, Twinax, Quadrax...) should not be used in firewall applications.

MIL-DTL-38999 **HD** arrangements and EN3645 Quadrax and/or grounded arrangements are given for information only. Not qualified. Amphenol designation only.

HD Quadrax & differential Twinax arrangements are **not rated over 175°C**.

23	22D	20	16	12	8	4	00	0000	High density	Ground plane version available	Quadrax available	Hermetic available	Lanyard release plug available	Coax or Twinax	Differential Twinax or Quadrax	Power contacts			

Front face of pin insert shown, master keyway illustrated.

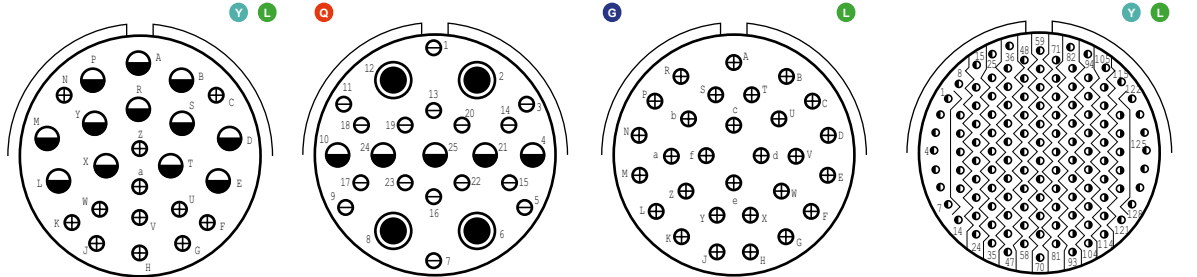

Series III/TV-CTV
Series II/JT
Series II/LJT (HE308)
MIL-DTL-38999 Series III
EN3645
Total contacts
Contact size

25-24
24-24
25-24
J24
12
16

25-26
/
16
20

25-29
24-29
25-29
J29
29
16

25-35
24-35
25-35
J35
JN35
128
22D

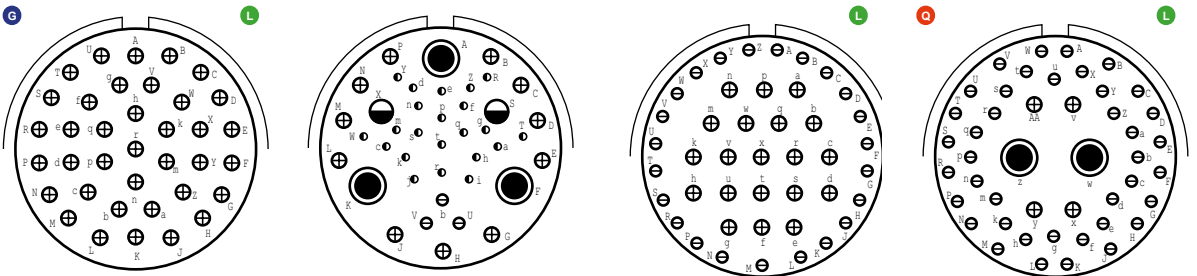

Series III/TV-CTV
Series II/JT
Series II/LJT (HE308)
MIL-DTL-38999 Series III
EN3645
Total contacts
Contact size

25-37
/
25-37
J37
37
16

25-41
/
22
22D

25-43
/
25-43
J43
23
20

25-46 / 25-47 ^{SB}
/
25-46
J46 / J47
40
20

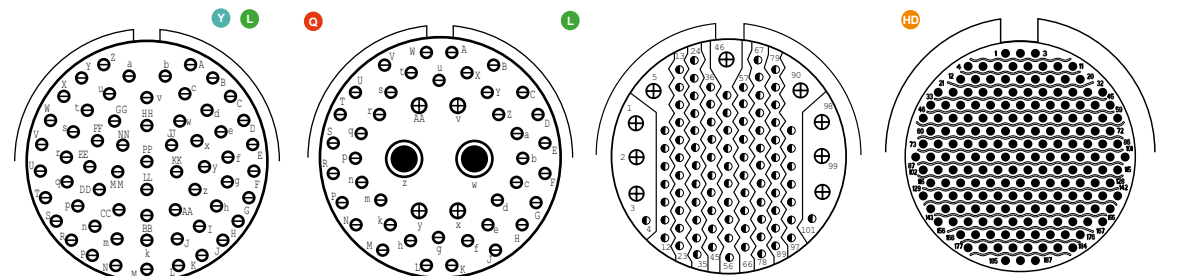

Series III/TV-CTV
Series II/JT
Series II/LJT (HE308)
MIL-DTL-38999 Series III
EN3645
Total contacts
Contact size

25-61
24-61
25-61 (25-61)
J61
JN61
61
20

25-90 / 25-91 ^{SB}
/
J90 / J91
40
20

25-92
/
92
22D

25-187
/
J23
187
23

^{SB} 25-47 and 25-91 contacts arrangement are intended to be used with D38999/62 sealing boots to seal the size 8 contacts
 Δ Delivered with Twinax contacts for simple braid cable (M17/1760002. AECMA Pr EN3375-003. Raychem 10612. EPD44690. EPD44691)
 / Not applicable

CONTACTS ARRANGEMENTS

As stated in MIL-DTL-38999 standard, insert arrangements using multi-axial contacts (Coax. Twinax. Quadrax...) should not be used in **firewall applications**.

MIL-DTL-38999 **HD** arrangements and EN3645 Quadrax and/or grounded arrangements are given for information only. Not qualified. **Amphenol designation only.**

HD, Quadrax & differential Twinax arrangements are **not rated over 175°C**.

●	◐	⊖	⊕	◑	●	○	⊗	⊙	HD	G	Q	Y	L	Coax or Twinax	Differential Twinax or Quadrax	Power contacts
23	22D	20	16	12	8	4	00	0000	High density	Ground plane version available	Quadrax available	Hermetic available	Lanyard release plug available	16, 12, 8	●	● ◐ ⊖ ⊕ ◑ ⊗ ⊙

Front face of pin insert shown, master keyway illustrated.

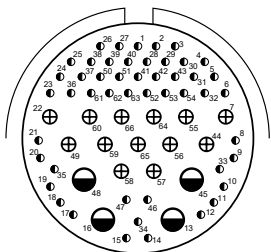

Series III/TV/CTV	25-F4		
Series III/JT	/		
Series III/JT (HE308)	/		
MIL-DTL-38999 Series III	/		
EN3645	/		
Total contacts	49	13	4
Contact size	22D	16	12

/ Not applicable

24
25

KEYWAY POSITION - CONNECTORS POLARIZATION

A plug with a given rotation letter will mate with a receptacle with the same rotation letter. This helps avoid mismatching and mating errors.

TV & CTV - MIL-DTL-38999 Series III

The angles for a given connector are the same whether it contains pins or sockets. Master key stays fixed, minor keys rotate. Inserts are not rotated in conjunction with the master key/keyway.

Size	Keyway arrangement identification letter	AR° or AP° BSC	BR° or BP° BSC	CR° or CP° BSC	DR° or DP° BSC
9	N*	105	140	215	265
	A	102	132	248	320
	B	80	118	230	312
	C	35	140	205	275
	D	64	155	234	304
11 to 15	E	91	131	197	240
	N*	95	141	208	236
	A	113	156	182	292
	B	90	145	195	252
	C	53	156	220	255
17 to 25	D	119	146	176	298
	E	51	141	184	242
	N*	80	142	196	293
	A	135	170	200	310
	B	49	169	200	244
	C	66	140	200	257
	D	62	145	180	280
	E	79	153	197	272

* N = D38999 part number ; (blank) = TV/CTV part number

Keyway identification letter is N, A, B, C, D or E.

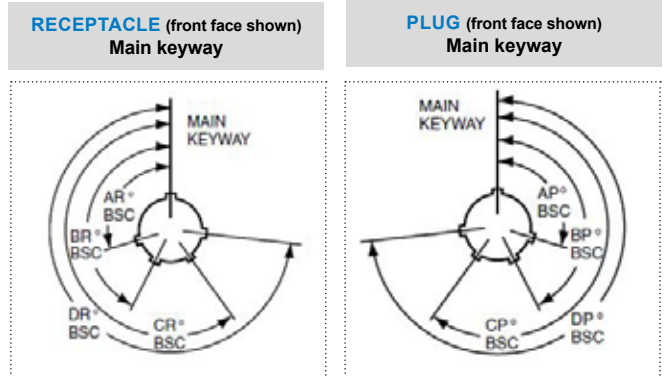

JT - MIL-DTL-38999 Series II

The angles for a given connector are the same whether it contains pins or sockets. Master key rotates, minors keys stay fixed. Inserts are not rotated in conjunction with the master key/keyway.

Shell size	Normal (blank)	Position of the major keyway			
		A	B	C	D
8	100°	82°	-	-	118°
10	100°	86°	72°	128°	114°
12	100°	80°	68°	132°	120°
14	100°	79°	66°	134°	121°
16	100°	82°	70°	130°	118°
18	100°	82°	70°	130°	118°
20	100°	82°	70°	130°	118°
22	100°	85°	74°	126°	115°
24	100°	85°	74°	126°	115°

Keyway identification letter is N, A, B, C, or D.

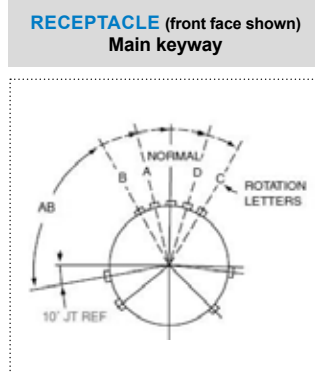

LJT - MIL-DTL-38999 Series I

The angles for a given connector are the same whether it contains pins or sockets. Master key rotates, minors keys stay fixed. Inserts are not rotated in conjunction with the master key/keyway.

Shell size	Normal (blank)	Position of the major keyway			
		A	B	C	D
9	95°	77°	-	-	113°
11	95°	81°	67°	123°	109°
13	95°	75°	63°	127°	115°
15	95°	74°	61°	129°	116°
17	95°	77°	65°	125°	113°
19	95°	77°	65°	125°	113°
21	95°	77°	65°	125°	113°
23	95°	80°	69°	121°	110°
25	95°	80°	69°	121°	110°

Keyway identification letter is N, A, B, C or D.

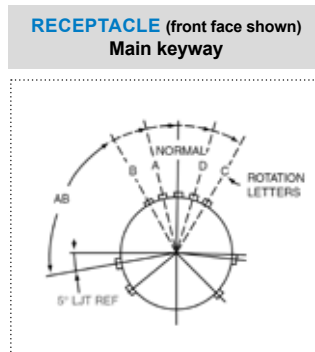

All dimensions are given for information only and are in mm, except as otherwise specified | *in mm: 1mm=0.03937 inch

PANEL HOLE DIMENSIONS

TV & CTV receptacles - MIL-DTL-38999 Series III

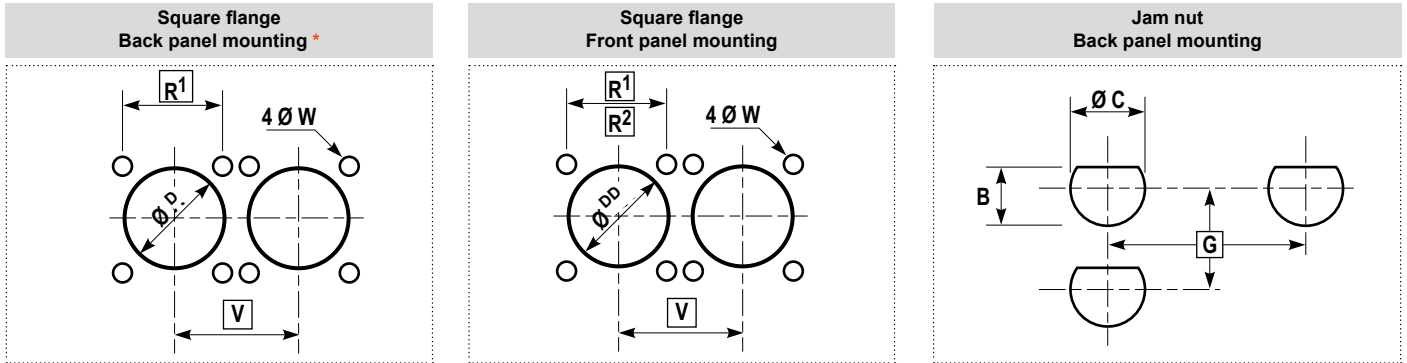

* Maximum panel thickness for back panel mounting: 5,8mm for size 9 to 19 & 5mm for size 21 to 25.

Size		R1	R2	ØW ±0.13	V	ØD _{MIN}	ØDD _{MIN}	G	ØC ^{+0 -0.25}	B ^{+0 -0.25}
APH	MIL									
9	A	18.26	15.09	3.25	24.6	16.66*	13.11*	27.8*	17.60*	16.70*
11	B	20.62	18.26	3.25	27.0	20.22	15.88	32.6	20.96	19.59
13	C	23.01	20.62	3.25	30.2	23.42	19.05	36.0	25.65	24.26
15	D	24.61	23.01	3.25	33.3	26.59	23.01	39.6	28.83	27.56
17	E	26.97	24.61	3.25	36.5	30.96	25.81	43.3	32.01	30.73
19	F	29.36	26.97	3.25	39.3	32.94	28.98	47.0	35.18	33.91
21	G	31.75	29.36	3.25	42.5	36.12	32.16	50.6	38.35	37.08
23	H	34.93	31.75	3.25	45.7	39.29	34.93	54.2	41.53	40.26
25	J	38.10	34.93	3.95	48.8	42.47	37.69	59.7	44.70	43.43

* Tolerance is ^{+0.10}
^{-0.06} for size A/9.

JT receptacles - MIL-DTL-38999 Series II

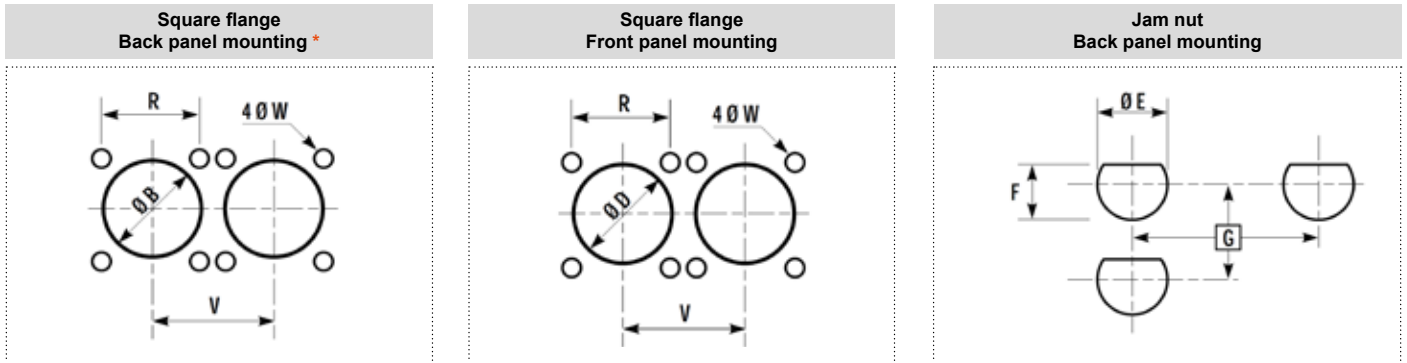

* Maximum panel thickness for back panel mounting: 3,73mm for size 8; 3,86mm for size 10 to 18; 4,55mm for size 20 and 22; & 4,29mm for size 24.

Size	R	ØB _{MIN}	V _{MIN}	ØW ±0.13	ØD _{MIN}	ØE _{MIN}	F ^{+0 -0.25}	G _{MIN}
8	15.09	14.30	21.45	3.25	11.63	22.46	21.08*	32.90
10	18.26	17.27	24.65	3.25	14.81	25.58	24.26	36.00
12	20.63	21.82	27.00	3.25	17.98	28.80	27.53	39.60
14	23.01	24.99	29.80	3.25	21.16	31.98	30.68	43.30
16	24.61	28.14	32.95	3.25	24.61	35.15	33.86	47.00
18	26.97	31.32	36.15	3.25	27.51	38.28	37.06	50.60
20	29.36	34.49	38.90	3.25	30.68	41.50	40.03	54.20
22	31.75	37.67	42.10	3.25	33.86	44.68	43.21	59.70
24	34.93	40.89	45.25	3.95	37.06	47.85	46.38	63.30

* Tolerance is ^{+0.10}
^{-0.06} for size A/8.

All dimensions are given for information only and are in mm, except as otherwise specified | *in mm: 1mm=0.03937 inch

Due to technical modifications, all information provided is subject to change without prior notice
Designed by Amphenol Socapex

PANEL HOLE DIMENSIONS

LJT receptacles - MIL-DTL-38999 Series I

**Square flange
Back panel mounting ***

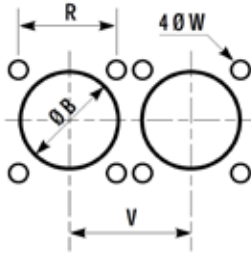

**Square flange
Front panel mounting**

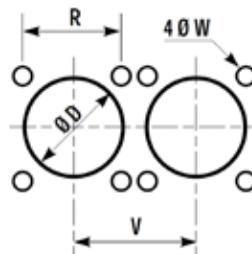

**Jam nut
Back panel mounting**

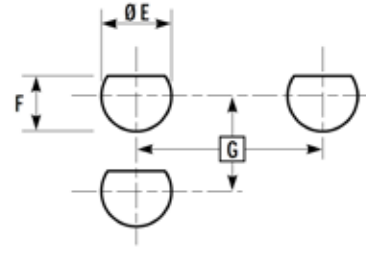

* Maximum panel thickness for back panel mounting: 5,94mm for size 9 to 19; 5,18mm for size 21 and 23; & 4,90mm for size 25

Shell Size	R	V ^{+0 -0.25}	ØW ^{+0 -0.25}	G _{MIN}	ØE _{MIN}	F ^{+0 -0.25}	ØB ^{+0 -0.41} _{MIN}	ØD ^{+0 -0.25} _{MIN}
9	18.26	24.60	3.25	27.80	17.70	16.99 *	16.81	13.11
11	20.62	27.00	3.25	32.60	20.88	19.53	20.57	15.88
13	23.01	30.20	3.25	36.00	25.58	24.26	24.38	19.05
15	24.61	33.30	3.25	39.60	28.80	27.53	27.56	23.01
17	26.97	36.50	3.25	43.30	31.98	30.68	30.73	25.81
19	29.36	39.30	3.25	47.00	35.16	33.86	33.45	28.98
21	31.75	42.50	3.25	50.60	38.28	37.06	36.53	32.16
23	34.93	45.70	3.73	54.20	41.50	40.01	39.30	34.93
25	38.10	48.80	3.73	59.70	44.68	43.41	42.98	37.69

* Tolerance is ^{+0.10}_{-0.06} for size A/9.

All dimensions are given for information only and are in mm, except as otherwise specified | *in mm: 1mm=0.03937 inch

Due to technical modifications, all information provided is subject to change without prior notice
Designed by Amphenol Socapex

Amphenol SOCAPEX



NOTES

A series of horizontal dotted lines for taking notes, spanning the width of the page.

PCB CONTACTS PATTERNS - PCB DRILLINGS

* Tin, tin lead, silver tin or silver tin copper drilling holes are identical.

PCB version are not QPL certified. Amphenol designation only.

Front face of pin insert shown.

ØA & ØB : recommended hole diameters, given for CI contacts.

09-09

HD III



9 contacts size 23

Cavity	X axis	Y axis
1	0	+2.67
2	+1.89	+1.89
3	+2.67	0
4	+1.89	-1.89
5	0	-2.67
6	-1.89	-1.89
7	-2.67	0
8	-1.89	+1.89
9	0	0
	Gold contacts	Tinned contacts*
ØA _{MIN}	0.8	0.9

09-35

I III

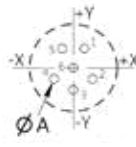

6 contacts size 22D

Cavity	X axis	Y axis
1	+ 1.14	+1.98
2	+ 1.98	-1.14
3	0	-2.29
4	-1.98	-1.14
5	-1.14	+1.98
6	0	0
	Gold contacts	Tinned contacts*
ØA _{MIN}	0.8	0.9

08-35

I

09-98

I III



3 contacts size 20

Cavity	X axis	Y axis
A	+1.65	+0.97
B	0	-1.91
C	-1.65	+0.97
	Gold contacts	Tinned contacts*
ØA _{MIN}	1.0	1.1

08-98

I

11-02

I III



2 contacts size 16

Cavity	X axis	Y axis
A	+2.41	0
B	-2.41	0
	Gold contacts	Tinned contacts*
ØA _{MIN}	1.45	1.55

11-04

I III



4 contacts size 20

Cavity	X axis	Y axis
A	+1.65	+1.65
B	+1.65	-1.65
C	-1.65	-1.65
D	-1.65	+1.65
	Gold contacts	Tinned contacts*
ØA _{MIN}	1.0	1.1

11-05

I III

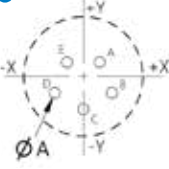

5 contacts size 20

Cavity	X axis	Y axis
A	+1.65	+1.42
B	+2.87	-1.65
C	0	-3.30
D	-2.87	-1.65
E	-1.65	+1.42
	Gold contacts	Tinned contacts*
ØA _{MIN}	1.0	1.1

10-05

I

11-12

I III



1 contact size 12

Cavity	X axis	Y axis
A	0	0
	Gold contacts	Tinned contacts*
ØA _{MIN}	2.0	2.1

11-19

HD III

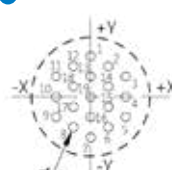

19 contacts size 23

Cavity	X axis	Y axis
1	0	+4.08
2	+1.77	+3.06
3	+3.53	+2.04
4	+3.53	0
5	+3.53	-2.04
6	+1.77	-3.06
7	0	-4.08
8	-1.77	-3.06
9	-3.53	-2.04
10	-3.53	0
11	-3.53	+2.04
12	-1.77	+3.06
13	0	+2.04
14	+1.77	+1.02
15	+1.77	-1.02
16	0	-2.04
17	-1.77	-1.02
18	-1.77	+1.02
19	0	0
	Gold contacts	Tinned contacts*
ØA _{MIN}	0.8	0.9

11-35

I III



13 contacts size 22D

Cavity	X axis	Y axis
1	0	+3.71
2	+2.16	+3.00
3	+3.51	+1.14
4	+3.51	-1.14
5	+2.16	-3.00
6	0	-3.71
7	-2.16	-3.00
8	-3.51	-1.14
9	-3.51	+1.14
10	-2.16	+3.00
11	0	+1.42
12	+1.24	-0.89
13	-1.24	-0.89
	Gold contacts	Tinned contacts*
ØA _{MIN}	0.8	0.9

10-35

I

11-98

I III



6 contacts size 20

Cavity	X axis	Y axis
A	0	+3.30
B	+3.30	0
C	+1.65	-2.87
D	-1.65	-2.87
E	-3.30	0
F	0	0
	Gold contacts	Tinned contacts*
ØA _{MIN}	1.0	1.1

10-98

I

11-99

I III



7 contacts size 20

Cavity	X axis	Y axis
A	+1.65	+2.87
B	+3.30	0
C	+1.65	-2.87
D	-1.65	-2.87
E	-3.30	0
F	-1.65	+2.87
G	0	0
	Gold contacts	Tinned contacts*
ØA _{MIN}	1.0	1.1

Note: shown in this catalog are the most common insert patterns for PCB applications. For availability of other arrangements, please consult Amphenol Socapex.

HD High density III Series III/TV-CTV I Series I/LJT

All dimensions are given for information only and are in mm, except as otherwise specified | *in mm: 1mm=0.03937 inch

PCB CONTACTS PATTERNS - PCB DRILLINGS

* Tin, tin lead, silver tin or silver tin copper drilling holes are identical.

PCB version are not QPL certified. Amphenol designation only.

Front face of pin insert shown.
 $\varnothing A$ & $\varnothing B$: recommended hole diameters, given for CI contacts.

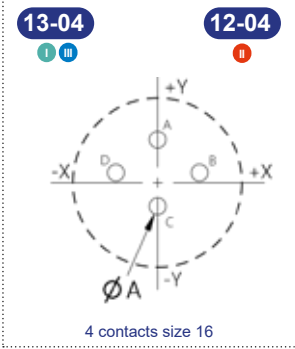

Cavity	X axis	Y axis
A	0	+3.81
B	+3.71	+0.89
C	0	-2.11
D	-3.71	+0.89
Gold contacts		Tinned contacts*
$\varnothing A_{MIN}$	1.45	1.55

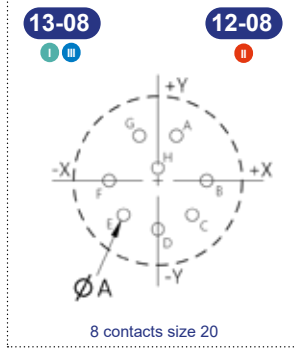

Cavity	X axis	Y axis
A	+1.65	+3.99
B	+4.32	0
C	+3.05	-3.05
D	0	-4.32
E	-3.05	-3.05
F	-4.32	0
G	-1.65	+3.99
H	0	+1.12
Gold contacts		Tinned contacts*
$\varnothing A_{MIN}$	1.0	1.1

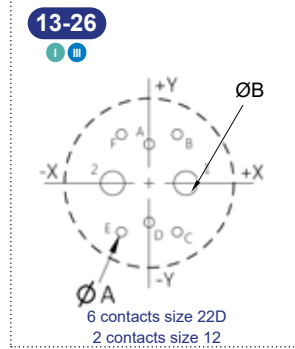

Cavity	X axis	Y axis
A	0	+3.47
B	+2.47	+4.34
C	+2.47	-4.34
D	0	-3.47
E	-2.47	-4.34
F	-2.47	+4.34
1	+3.25	0
2	-3.25	0
Gold contacts		Tinned contacts*
$\varnothing A_{MIN}$	0.8	0.9
$\varnothing B_{MIN}$	2.0	2.1

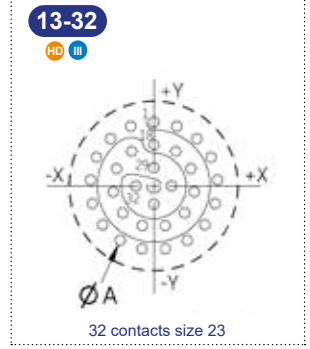

Cavity	X axis	Y axis
1	0	+5.68
2	+2.05	+5.30
3	+3.83	+4.20
4	+5.09	+2.53
5	+5.66	+0.52
6	+5.46	-1.55
7	+4.53	-3.42
8	+2.99	-4.83
9	+1.04	-5.58
10	-1.04	-5.58
11	-2.99	-4.83
12	-4.53	-3.42
13	-5.46	-1.55
14	-5.66	+0.52
15	-5.09	+2.53
16	-3.83	+4.20
17	-2.05	+5.30
18	0	+5.68
19	+1.97	+3.06
20	+3.31	+1.51
21	+3.60	-0.52
22	+2.75	-2.38
23	+1.03	-3.49
24	-1.03	-3.49
25	-2.75	-2.38
26	-3.60	-0.52
27	-3.31	+1.51
28	-1.97	+3.06
29	0	+1.60
30	+1.60	0
31	0	-1.60
32	-1.60	0
Gold contacts		Tinned contacts*
$\varnothing A_{MIN}$	0.8	0.9

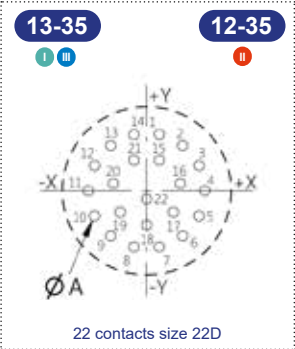

Cavity	X axis	Y axis
1	+1.14	+5.00
2	+3.20	+4.01
3	+4.62	+2.24
4	+5.16	0
5	+4.62	-2.24
6	+3.20	-4.01
7	+1.14	-5.00
8	-1.14	-5.00
9	-3.20	-4.01
10	-4.62	-2.24
11	-5.16	0
12	-4.62	+2.24
13	-3.20	+4.01
14	-1.14	+5.00
15	+1.14	+2.72
16	+2.97	+0.66
17	+2.36	-1.91
18	0	-3.05
19	-2.36	-1.91
20	-2.97	+0.66
21	-1.14	+2.72
22	0	-0.76
Gold contacts		Tinned contacts*
$\varnothing A_{MIN}$	0.8	0.9

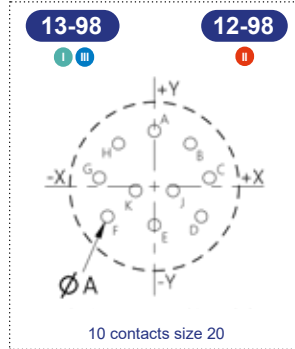

Cavity	X axis	Y axis
A	0	+4.95
B	+3.18	+3.81
C	+4.90	+0.76
D	+4.17	-2.67
E	0	-3.43
F	-4.17	-2.67
G	-4.90	+0.76
H	-3.18	+3.81
J	+1.65	-0.38
K	-1.65	-0.38
Gold contacts		Tinned contacts*
$\varnothing A_{MIN}$	1.0	1.1

HD High density III Series III/TV-CTV II Series II/JT I Series I/LJT

Note: shown in this catalog are the most common insert patterns for PCB applications. For availability of other arrangements, please consult Amphenol Socapex.

PCB CONTACTS PATTERNS - PCB DRILLINGS

* Tin, tin lead, silver tin or silver tin copper drilling holes are identical.

PCB version are not QPL certified. Amphenol designation only.

Front face of pin insert shown.
 $\varnothing A$ & $\varnothing B$: recommended hole diameters, given for CI contacts.

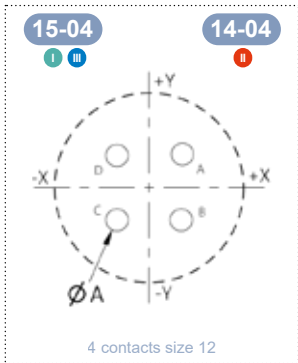

Cavity	X axis	Y axis
A	+3.18	+3.18
B	+3.18	-3.18
C	-3.18	-3.18
D	-3.18	+3.18
	Gold contacts	Tinned contacts*
$\varnothing A_{MIN}$	2.0	2.1

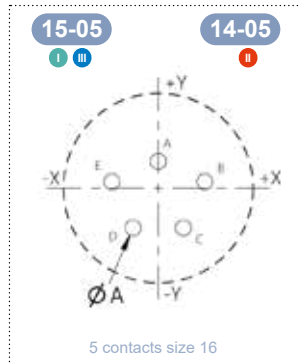

Cavity	X axis	Y axis
A	0	+2.54
B	+4.42	+0.61
C	+2.39	-3.76
D	-2.39	-3.76
E	-4.42	+0.61
	Gold contacts	Tinned contacts*
$\varnothing A_{MIN}$	1.45	1.55

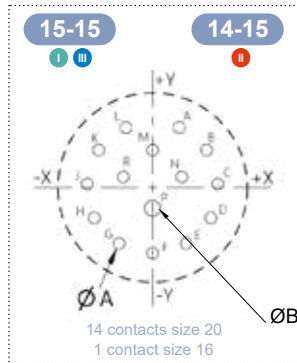

Cavity	X axis	Y axis
A	+2.54	+5.72
B	+5.13	+3.56
C	+6.20	+0.36
D	+5.54	-2.87
E	+3.20	-5.31
F	0	-6.22
G	-3.20	-5.31
H	-5.54	-2.87
J	-6.20	+0.36
K	-5.13	+3.56
L	-2.54	+5.72
M	0	+3.56
N	+2.79	+1.02
P	0	-1.96
R	-2.79	+1.02
	Gold contacts	Tinned contacts*
$\varnothing A_{MIN}$	1.0	1.1
$\varnothing B_{MIN}$	1.45	1.55

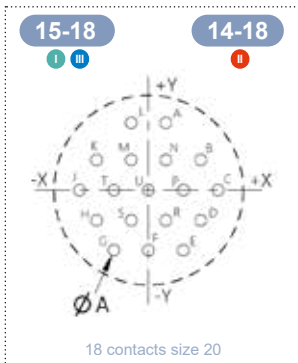

Cavity	X axis	Y axis
A	+1.65	+6.40
B	+4.95	+2.87
C	+6.60	0
D	+4.95	-2.87
E	+3.30	-5.72
F	0	-5.72
G	-3.30	-5.72
H	-4.95	-2.87
J	-6.60	0
K	-4.95	+2.87
L	-1.65	+6.40
M	-1.65	+2.87
N	+1.65	+2.87
P	+3.30	0
R	+1.65	-2.87
S	-1.65	-2.87
T	-3.30	0
U	0	0
	Gold contacts	Tinned contacts*
$\varnothing A_{MIN}$	1.0	1.1

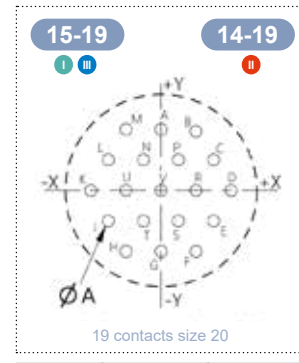

Cavity	X axis	Y axis
A	0	+5.72
B	+3.30	+5.72
C	+4.95	+2.87
D	+6.60	0
E	+4.95	-2.87
F	+3.30	-5.72
G	0	-5.72
H	-3.30	-5.72
J	-4.95	-2.87
K	-6.60	0
L	-4.95	+2.87
M	-3.30	+5.72
N	-1.65	+2.87
P	+1.65	+2.87
R	+3.30	0
S	+1.65	-2.87
T	-1.65	-2.87
U	-3.30	0
V	0	0
	Gold contacts	Tinned contacts*
$\varnothing A_{MIN}$	1.0	1.1

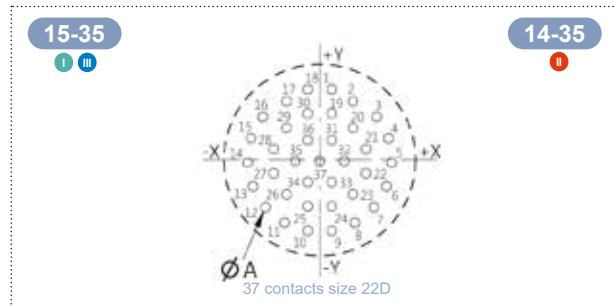

Cavity	X axis	Y axis	Cavity	X axis	Y axis
1	+1.14	+6.65	21	+4.32	+1.02
2	+3.12	+5.51	22	+4.32	-1.27
3	+5.36	+4.06	23	+3.12	-3.23
4	+6.45	+2.03	24	+1.14	-4.37
5	+6.76	-0.25	25	-1.14	-4.37
6	+6.27	-2.49	26	-3.12	-3.23
7	+5.08	-4.45	27	-4.32	-1.27
8	+3.30	-5.89	28	-4.32	+1.02
9	+1.14	-6.65	29	-3.12	+3.02
10	-1.14	-6.65	30	-1.14	+4.37
11	-3.30	-5.89	31	+1.14	+1.88
12	-5.08	-4.45	32	+2.29	-0.10
13	-6.27	-2.49	33	+1.14	-2.08
14	-6.76	-0.25	34	-1.14	-2.08
15	-6.45	+2.03	35	-2.29	-0.10
16	-5.36	+4.06	36	-1.14	+1.88
17	-3.12	+5.51	37	0	-0.10
18	-1.14	+6.65		Gold contacts	Tinned contacts*
19	+1.14	+4.37	$\varnothing A_{MIN}$	0.8	0.9
20	+3.12	+3.02			

Note: shown in this catalog are the most common insert patterns for PCB applications. For availability of other arrangements, please consult Amphenol Socapex.

HD High density III Series III/TV-CTV II Series II/JT I Series I/LJT

PCB CONTACTS PATTERNS - PCB DRILLINGS

* Tin, tin lead, silver tin or silver tin copper drilling holes are identical.

PCB version are not QPL certified. Amphenol designation only.

Front face of pin insert shown.
 $\varnothing A$ & $\varnothing B$: recommended hole diameters, given for CI contacts.

15-55

HD III

55 contacts size 23

15-97

I III

8 contacts size 20
4 contacts size 16

14-97

II

8 contacts size 20
4 contacts size 16

Cavity	X axis	Y axis	Cavity	X axis	Y axis	Cavity	X axis	Y axis
1	-2.04	+7.07	19	-3.06	+1.77	37	+3.06	-1.77
2	0	+7.07	20	-1.02	+1.77	38	+5.10	-1.77
3	+2.04	+7.07	21	+1.02	+1.77	39	+7.14	-1.77
4	-5.10	+5.30	22	+3.06	+1.77	40	-6.12	-3.53
5	-3.06	+5.30	23	+5.10	+1.77	41	-4.08	-3.53
6	-1.02	+5.30	24	+7.14	+1.77	42	-2.04	-3.53
7	+1.02	+5.30	25	-6.12	0	43	0	-3.53
8	+3.06	+5.30	26	-4.08	0	44	+2.04	-3.53
9	+5.10	+5.30	27	-2.04	0	45	+4.08	-3.53
10	-6.12	+3.53	28	0	0	46	+6.12	-3.53
11	-4.08	+3.53	29	+2.04	0	47	-5.10	-5.30
12	-2.04	+3.53	30	+4.08	0	48	-3.06	-5.30
13	0	+3.53	31	+6.12	0	49	-1.02	-5.30
14	+2.04	+3.53	32	-7.14	-1.77	50	+1.02	-5.30
15	+4.08	+3.53	33	-5.10	-1.77	51	+3.06	-5.30
16	+6.12	+3.53	34	-3.06	-1.77	52	+5.10	-5.30
17	-7.14	+1.77	35	-1.02	-1.77	53	-2.04	-7.07
18	-5.10	+1.77	36	+1.02	-1.77	54	0	-7.07
						55	+2.04	-7.07
			Gold contacts		Tinned contacts*			
$\varnothing A_{MIN}$	0.8		$\varnothing A_{MIN}$	0.8		$\varnothing A_{MIN}$	0.8	0.9

14
15

17-06

I III

6 contacts size 12

16-06

II

6 contacts size 12

Cavity	X axis	Y axis	Cavity	X axis	Y axis	
A	+3.07	+5.31	A	0	+5.99	
B	+6.12	0	B	+3.25	+2.18	
C	0	-6.12	C	+5.84	-1.98	
D	-6.12	0	D	+2.39	-5.49	
E	-3.07	+5.31	E	-2.39	-5.49	
F	0	0	F	-5.84	-1.98	
			Gold contacts		Tinned contacts*	
$\varnothing A_{MIN}$	2.0	2.1	$\varnothing A_{MIN}$	1.45	1.55	

17-08

I III

8 contacts size 16

16-08

II

8 contacts size 16

Cavity	X axis	Y axis	Cavity	X axis	Y axis	
A	0	+5.99	P	-6.07	+5.44	
B	+3.25	+2.18	R	-3.33	+7.44	
C	+5.84	-1.98	S	-1.78	+4.50	
D	+2.39	-5.49	T	+1.78	+4.50	
E	-2.39	-5.49	U	+4.45	+2.39	
F	-5.84	-1.98	V	+4.52	-0.91	
G	-3.25	+2.18	W	+3.02	-3.84	
H	0	-1.32	X	0	-5.16	
			Gold contacts		Tinned contacts*	
$\varnothing A_{MIN}$	1.45	1.55	$\varnothing A_{MIN}$	1.0	1.1	

17-26

I III

26 contacts size 20

16-26

II

26 contacts size 20

Cavity	X axis	Y axis	Cavity	X axis	Y axis	
A	0	+8.15	P	-6.07	+5.44	
B	+3.33	+7.44	R	-3.33	+7.44	
C	+6.07	+5.44	S	-1.78	+4.50	
D	+7.75	+2.51	T	+1.78	+4.50	
E	+8.10	-0.86	U	+4.45	+2.39	
F	+7.06	-4.09	V	+4.52	-0.91	
G	+4.80	-6.60	W	+3.02	-3.84	
H	+1.70	-7.98	X	0	-5.16	
J	-1.70	-7.98	Y	-3.02	-3.84	
K	-4.80	-6.60	Z	-4.52	-0.91	
L	-7.06	-4.09	a	-4.45	+2.39	
M	-8.10	-0.86	b	0	+1.65	
N	-7.75	+2.51	c	0	-1.65	
			Gold contacts		Tinned contacts*	
$\varnothing A_{MIN}$	1.0	1.1	$\varnothing A_{MIN}$	1.0	1.1	

16
17

Note: shown in this catalog are the most common insert patterns for PCB applications. For availability of other arrangements, please consult Amphenol Socapex.

HD High density III Series III/TV-CTV II Series II/JT I Series I/LJT

PCB CONTACTS PATTERNS - PCB DRILLINGS

* Tin, tin lead, silver tin or silver tin copper drilling holes are identical.

Front face of pin insert shown.

ØA & ØB : recommended hole diameters, given for CI contacts.

PCB version are not QPL certified. Amphenol designation only.

17-35

I III

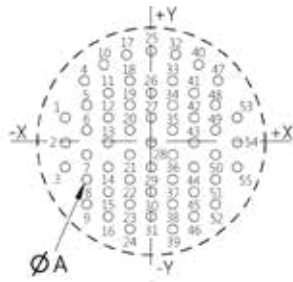

55 contacts size 22D

16-35

II

17-20

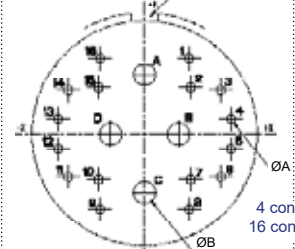

4 contacts size 12
16 contacts size 22D

Cavity	X axis	Y axis
1	-7.92	+2.18
2	-7.92	-0.10
3	-7.92	-2.39
4	-6.15	+5.61
5	-5.94	+3.33
6	-5.94	+1.04
7	-5.94	-1.24
8	-5.94	-3.53
9	-5.94	-5.82
10	-4.37	+7.09
11	-3.96	+4.47
12	-3.96	+2.18
13	-3.96	-0.10
14	-3.96	-2.39
15	-3.96	-4.67
16	-3.96	-6.96
17	-2.26	+8.03
18	-1.98	+5.61
19	-1.98	+3.33

Cavity	X axis	Y axis
20	-1.98	+1.04
21	-1.98	-1.24
22	-1.98	-3.53
23	-1.98	-5.82
24	-1.98	-8.10
25	0	+8.36
26	0	+4.47
27	0	+2.18
28	0	-0.10
29	0	-2.39
30	0	-4.67
31	0	-6.96
32	+2.26	+8.03
33	+1.98	+5.61
34	+1.98	+3.33
35	+1.98	+1.04
36	+1.98	-1.24
37	+1.98	-3.53
38	+1.98	-5.82

Cavity	X axis	Y axis
39	+1.98	-8.10
40	+4.37	+7.09
41	+3.96	+4.47
42	+3.96	+2.18
43	+3.96	-0.10
44	+3.96	-2.39
45	+3.96	-4.67
46	+3.96	-6.96
47	+6.15	+5.61
48	+5.94	+3.33
49	+5.94	+1.04
50	+5.94	-1.24
51	+5.94	-3.53
52	+5.94	-5.82
53	+7.92	+2.18
54	+7.92	-0.10
55	+7.92	-2.39
	Gold contacts	Tinned contacts*
ØA _{MIN}	0.8	0.9

Cavity	X axis	Y axis
1	+4.17	+7.06
2	+4.29	+4.29
3	+7.11	+4.04
4	+8.05	+1.40
5	+8.05	-4.04
6	+7.11	-4.29
7	+4.29	-7.06
8	+4.17	-7.06
9	-4.17	-4.29
10	-4.29	-4.04
11	-7.11	-1.40
12	-8.05	-1.40
13	-8.05	+1.40
14	-7.11	+4.04
15	-4.29	4.29
16	-4.17	7.06
A	0	+5.51
B	+3.18	0
C	0	-5.51
D	-3.18	0
	Gold contacts	Tinned contacts*
ØA _{MIN}	0.8	0.9
ØB _{MIN}	2.0	2.1

17-73

HD III

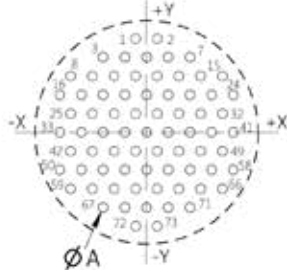

73 contacts size 23

17-99

I II

16-99

II ØB

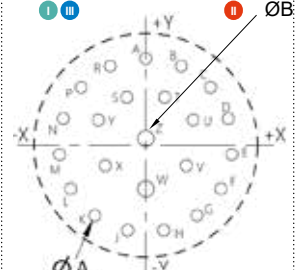

21 contacts size 20
2 contacts size 16

Cavity	X axis	Y axis
1	-1.02	+8.83
2	+1.02	+8.83
3	-4.08	+7.07
4	-2.04	+7.07
5	0	+7.07
6	+2.04	+7.07
7	+4.08	+7.07
8	-7.14	+5.30
9	-5.10	+5.30
10	-3.06	+5.30
11	-1.02	+5.30
12	+1.02	+5.30
13	+3.06	+5.30
14	+5.10	+5.30
15	+7.14	+5.30
16	-8.16	+3.53
17	-6.12	+3.53
18	-4.08	+3.53
19	-2.04	+3.53
20	0	+3.53
21	+2.04	+3.53
22	+4.08	+3.53
23	+6.12	+3.53
24	+8.16	+3.53
25	-7.14	+1.77

Cavity	X axis	Y axis
26	-5.10	+1.77
27	-3.06	+1.77
28	-1.02	+1.77
29	+1.02	+1.77
30	+3.06	+1.77
31	+5.10	+1.77
32	+7.14	+1.77
33	-8.16	0
34	-6.12	0
35	-4.08	0
36	-2.04	0
37	0	0
38	+2.04	0
39	+4.08	0
40	+6.12	0
41	+8.16	0
42	-7.14	-1.77
43	-5.10	-1.77
44	-3.06	-1.77
45	-1.02	-1.77
46	+1.02	-1.77
47	+3.06	-1.77
48	+5.10	-1.77
49	+7.14	-1.77
50	-8.16	-3.53

Cavity	X axis	Y axis
51	-6.12	-3.53
52	-4.08	-3.53
53	-2.04	-3.53
54	0	-3.53
55	+2.04	-3.53
56	+4.08	-3.53
57	+6.12	-3.53
58	+8.16	-3.53
59	-7.14	-5.30
60	-5.10	-5.30
61	-3.06	-5.30
62	-1.02	-5.30
63	+1.02	-5.30
64	+3.06	-5.30
65	+5.10	-5.30
66	+7.14	-5.30
67	-4.08	-7.07
68	-2.04	-7.07
69	0	-7.07
70	+2.04	-7.07
71	+4.08	-7.07
72	-1.02	-8.83
73	+1.02	-8.83
	Gold contacts	Tinned contacts*
ØA _{MIN}	0.8	0.9

Cavity	X axis	Y axis
A	0	+8.15
B	+3.33	+7.44
C	+6.07	+5.44
D	+7.75	+2.51
E	+8.10	-0.86
F	+7.06	-4.09
G	+4.80	-6.60
H	+1.70	-7.98
J	-1.70	-7.98
K	-4.80	-6.60
L	-7.06	-4.09
M	-8.10	-0.86
N	-7.75	+2.51
P	-6.07	+5.44
R	-3.33	+7.44
S	-1.78	+4.50
T	+1.78	+4.50
U	+4.45	+2.39
V	+3.81	-1.91
W	0	-4.09
X	-3.81	-1.91
Y	-4.45	+2.39
Z	0	+0.64
	Gold contacts	Tinned contacts*
ØA _{MIN}	1.0	1.1
ØB _{MIN}	1.45	1.55

Note: shown in this catalog are the most common insert patterns for PCB applications. For availability of other arrangements, please consult Amphenol Socapex.

HD High density

III Series III/TV-CTV

II Series II/JT

I Series I/LJT

PCB CONTACTS PATTERNS - PCB DRILLINGS

* Tin, tin lead, silver tin or silver tin copper drilling holes are identical.

Front face of pin insert shown.

ØA & ØB : recommended hole diameters, given for CI contacts.

PCB version are not QPL certified. Amphenol designation only.

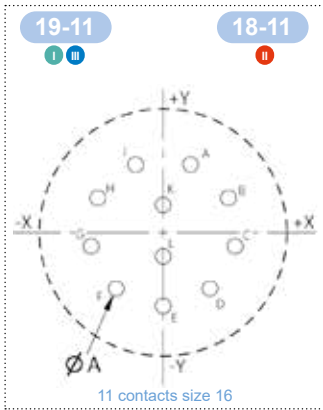

Cavity	X axis	Y axis
A	+2.67	+6.60
B	+6.35	+3.65
C	+6.99	-1.35
D	+4.55	-5.46
E	0	-7.14
F	-4.55	-5.46
G	-6.99	-1.35
H	-6.35	+3.35
J	-2.67	+6.60
K	0	+2.67
L	0	-2.34
	Gold contacts	Tinned contacts*
ØA _{MIN}	1.45	1.55

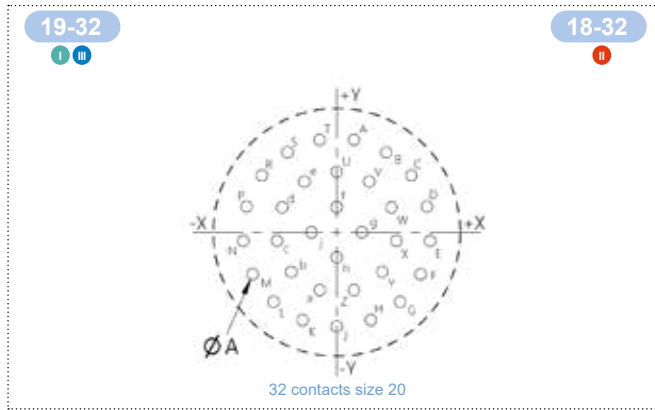

Cavity	X axis	Y axis	Cavity	X axis	Y axis
A	+1.68	+8.97	T	-1.68	+8.97
B	+4.80	+7.75	U	0	+5.84
C	+7.26	+5.51	V	+3.15	+4.90
D	+8.76	+2.49	W	+5.31	+2.41
E	+9.07	-0.84	X	+5.79	-0.84
F	+8.15	-4.06	Y	+4.42	-3.84
G	+6.15	-6.73	Z	+1.65	-5.61
H	+3.30	-8.51	a	-1.65	-5.61
J	0	-9.12	b	-4.42	-3.84
K	-3.30	-8.51	c	-5.79	-0.84
L	-6.15	-6.73	d	-5.31	+2.41
M	-8.15	-4.06	e	-3.15	+4.90
N	-9.07	-0.84	f	0	+2.44
P	-8.76	+2.49	g	+2.44	0
R	-7.26	+5.51	h	0	-2.44
S	-4.80	+7.75	j	-2.44	0
	Gold contacts	Tinned contacts*			
ØA _{MIN}	1.0	1.1			

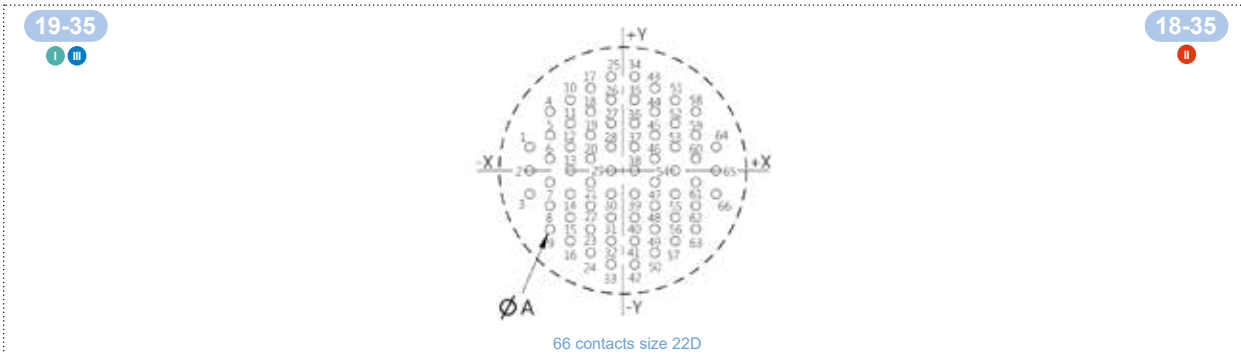

Cavity	X axis	Y axis	Cavity	X axis	Y axis	Cavity	X axis	Y axis	Cavity	X axis	Y axis
1	-9.07	+2.29	19	-3.12	+3.43	37	+1.14	+2.29	55	+5.11	-2.29
2	-9.07	0	20	-3.12	+1.14	38	+1.14	0	56	+5.11	-4.57
3	-9.07	-2.29	21	-3.12	-1.14	39	+1.14	-2.29	57	+5.11	-6.86
4	-7.09	+5.72	22	-3.12	-3.43	40	+1.14	-4.57	58	+7.09	+5.72
5	-7.09	+3.43	23	-3.12	-5.72	41	+1.14	-6.86	59	+7.09	+3.43
6	-7.09	+1.14	24	-3.12	-8.00	42	+1.14	-9.14	60	+7.09	+1.14
7	-7.09	-1.14	25	-1.14	+9.14	43	+3.12	+8.00	61	+7.09	-1.14
8	-7.09	-3.43	26	-1.14	+6.86	44	+3.12	+5.72	62	+7.09	-3.43
9	-7.09	-5.72	27	-1.14	+4.57	45	+3.12	+3.43	63	+7.09	-5.72
10	-5.11	+6.86	28	-1.14	+2.29	46	+3.12	+1.14	64	+9.07	+2.29
11	-5.11	+4.57	29	-1.14	0	47	+3.12	-1.14	65	+9.07	0
12	-5.11	+2.29	30	-1.14	-2.29	48	+3.12	-3.43	66	+9.07	-2.29
13	-5.11	0	31	-1.14	-4.57	49	+3.12	-5.72		Gold contacts	Tinned contacts*
14	-5.11	-2.29	32	-1.14	-6.86	50	+3.12	-8.00	ØA _{MIN}	0.8	0.9
15	-5.11	-4.57	33	-1.14	-9.14	51	+5.11	+6.86			
16	-5.11	-6.86	34	+1.14	+9.14	52	+5.11	+4.57			
17	-3.12	+8.00	35	+1.14	+6.86	53	+5.11	+2.29			
18	-3.12	+5.72	36	+1.14	+4.57	54	+5.11	0			

Note: shown in this catalog are the most common insert patterns for PCB applications. For availability of other arrangements, please consult Amphenol Socapex.

HD High density III Series III/TV-CTV II Series II/JT I Series I/LJT

Due to technical modifications, all information provided is subject to change without prior notice. Designed by Amphenol Socapex

PCB CONTACTS PATTERNS - PCB DRILLINGS

* Tin, tin lead, silver tin or silver tin copper drilling holes are identical.

PCB version are not QPL certified. Amphenol designation only.

Front face of pin insert shown.

ØA & ØB : recommended hole diameters, given for CI contacts.

19-88

HD III

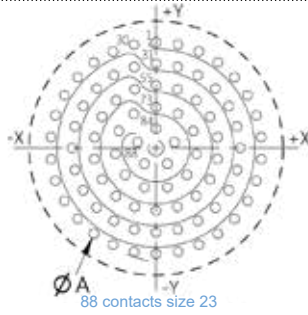

Cavity	X axis	Y axis	Cavity	X axis	Y axis	Cavity	X axis	Y axis	Cavity	X axis	Y axis
1	0	+9.99	24	-9.93	+1.04	47	-6.88	-3.97	70	-5.11	+2.95
2	+2.08	+9.77	25	-9.50	+3.09	48	-7.67	-2.06	71	-3.80	+4.52
3	+4.06	+9.12	26	-8.65	+4.99	49	-7.95	0	72	-2.02	+5.55
4	+5.87	+8.08	27	-7.42	+6.68	50	-7.67	+2.06	73	0	+3.87
5	+7.42	+6.68	28	-5.87	+8.08	51	-6.88	+3.97	74	+2.09	+3.25
6	+8.65	+4.99	29	-4.06	+9.12	52	-5.62	+5.62	75	+3.52	+1.61
7	+9.50	+3.09	30	-2.08	+9.77	53	-3.97	+6.88	76	+3.83	-0.55
8	+9.93	+1.04	31	0	+7.95	54	-2.06	+7.67	77	+2.92	-2.53
9	+9.93	-1.04	32	+2.06	+7.67	55	0	+5.91	78	+1.09	-3.71
10	+9.50	-3.09	33	+3.97	+6.88	56	+2.02	+5.55	79	-1.09	-3.71
11	+8.65	-4.99	34	+5.62	+5.62	57	+3.80	+4.52	80	-2.92	-2.53
12	+7.42	-6.68	35	+6.88	+3.97	58	+5.11	+2.95	81	-3.83	-0.55
13	+5.87	-8.08	36	+7.67	+2.06	59	+5.82	+1.03	82	-3.52	+1.61
14	+4.06	-9.12	37	+7.95	0	60	+5.82	-1.03	83	-2.09	+3.25
15	+2.08	-9.77	38	+7.67	-2.06	61	+5.11	-2.95	84	0	+1.83
16	0	-9.99	39	+6.88	-3.97	62	+3.80	-4.52	85	+1.74	+0.56
17	-2.08	-9.77	40	+5.62	-5.62	63	+2.02	-5.55	86	+1.09	-1.48
18	-4.06	-9.12	41	+3.97	-6.88	64	0	-5.91	87	-1.09	-1.48
19	-5.87	-8.08	42	+2.06	-7.67	65	-2.02	-5.55	88	-1.74	+0.56
20	-7.42	-6.68	43	0	-7.95	66	-3.80	-4.52		Gold contacts	Tinned contacts*
21	-8.65	-4.99	44	-2.06	-7.67	67	-5.11	-2.95	ØA _{MIN}	0.8	0.9
22	-9.50	-3.09	45	-3.97	-6.88	68	-5.82	-1.03			
23	-9.93	-1.04	46	-5.62	-5.62	69	-5.82	+1.03			

18
19

21-11

I III

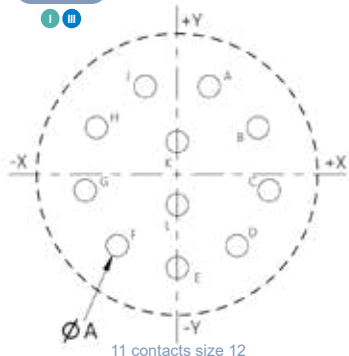

Cavity	X axis	Y axis
A	+3.07	+8.43
B	+7.77	+4.50
C	+8.84	-1.55
D	+5.77	-6.86
E	0	-8.97
F	-5.77	-6.86
G	-8.84	-1.55
H	-7.77	+4.50
J	-3.07	+8.43
K	0	+3.12
L	0	-2.92
	Gold contacts	Tinned contacts*
ØA _{MIN}	2.0	2.1

21-16

I III

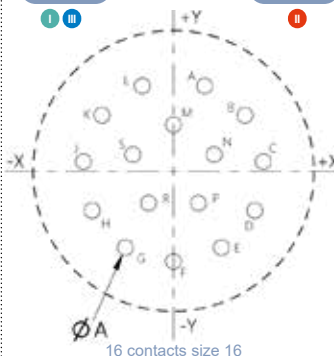

Cavity	X axis	Y axis
A	+3.00	+8.18
B	+6.88	+5.36
C	+8.66	+0.91
D	+7.82	-3.81
E	+4.62	-7.37
F	0	-8.71
G	-4.62	-7.37
H	-7.82	-3.81
J	-8.66	+0.91
K	-6.88	+5.36
L	-3.00	+8.18
M	0	+4.45
N	+3.91	+1.57
P	+2.39	-3.10
R	-2.39	-3.10
S	-3.91	+1.57
	Gold contacts	Tinned contacts*
ØA _{MIN}	1.45	1.55

20-16

I

21-29

III

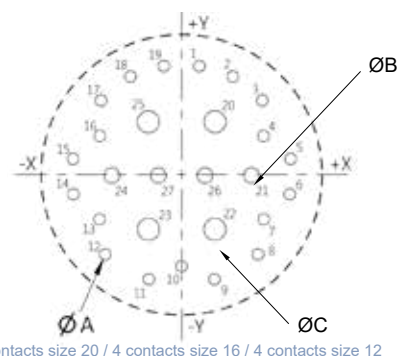

Cavity	X axis	Y axis	Cavity	X axis	Y axis
1	+1.70	+10.46	16	-7.87	+3.71
2	+4.93	+9.45	17	-7.45	+7.14
3	+7.45	+7.14	18	-4.93	+9.45
4	+7.87	+3.71	19	-1.70	+10.46
5	+10.46	+1.52	20	+3.20	+5.08
6	+10.39	-1.88	21	+6.71	-0.08
7	+7.90	-4.29	22	+3.18	-5.26
8	+7.34	-7.67	23	-3.18	-5.26
9	+3.15	-10.08	24	-6.71	-0.08
10	0	-8.81	25	-3.20	+5.08
11	-3.15	-10.08	26	+2.24	-0.08
12	-7.34	-7.67	27	-2.24	-0.08
13	-7.90	-4.29		Gold contacts	Tinned contacts*
14	-10.39	-1.88	ØA _{MIN}	1.0	1.1
15	-10.46	+1.52	ØB _{MIN}	1.45	1.55
			ØC _{MIN}	2.0	2.1

20
21

Note: shown in this catalog are the most common insert patterns for PCB applications. For availability of other arrangements, please consult Amphenol Socapex.

HD High density III Series III/TV-CTV I Series II/JT I Series I/LJT

PCB CONTACTS PATTERNS - PCB DRILLINGS

* Tin, tin lead, silver tin or silver tin copper drilling holes are identical.

PCB version are not QPL certified. Amphenol designation only.

Front face of pin insert shown.
ØA & ØB : recommended hole diameters, given for CI contacts.

21-35

I III

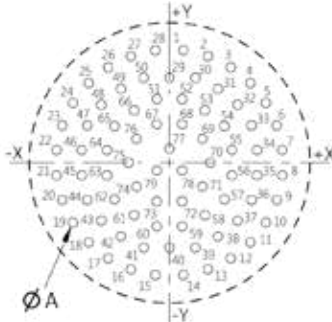

79 contacts size 22D

20-35

II

Cavity	X axis	Y axis	Cavity	X axis	Y axis	Cavity	X axis	Y axis	Cavity	X axis	Y axis
1	+1.35	+10.82	23	-10.31	+3.58	45	-8.43	-1.22	67	-1.22	+3.71
2	+3.71	+10.26	24	-9.27	+5.77	46	-8.43	+1.22	68	+1.22	+3.71
3	+5.89	+9.19	25	-7.77	+7.67	47	-7.90	+3.58	69	+3.18	+2.29
4	+7.77	+7.67	26	-5.89	+9.19	48	-6.55	+5.59	70	+3.94	0
5	+9.27	+5.77	27	-3.71	+10.26	49	-4.67	+7.11	71	+3.18	-2.29
6	+10.31	+3.58	28	-1.35	+10.82	50	-2.49	+8.18	72	+1.22	-3.71
7	+10.85	+1.22	29	0	+8.20	51	-1.22	+6.12	73	-1.22	-3.71
8	+10.85	-1.22	30	+2.49	+8.18	52	+1.22	+6.12	74	-3.18	-2.29
9	+10.31	-3.58	31	+4.67	+7.11	53	+3.40	+5.05	75	-3.94	0
10	+9.27	-5.77	32	+6.55	+5.59	54	+5.28	+3.53	76	-3.18	+2.29
11	+7.77	-7.67	33	+7.90	+3.58	55	+6.02	+1.22	77	0	+1.35
12	+5.89	-9.19	34	+8.43	+1.22	56	+6.02	-1.22	78	+1.22	-0.74
13	+3.71	-10.26	35	+8.43	-1.22	57	+5.28	-3.53	79	-1.22	-0.74
14	+1.35	-10.82	36	+7.90	-3.58	58	+3.40	-5.05	Gold contacts		Tinned contacts*
15	-1.35	-10.82	37	+6.55	-5.59	59	+1.22	-6.12	ØA _{MIN}	0.8	0.9
16	-3.71	-10.26	38	+4.67	-7.11	60	-1.22	-6.12			
17	-5.89	-9.19	39	+2.49	-8.18	61	-3.40	-5.05			
18	-7.77	-7.67	40	0	-8.81	62	-5.28	-3.53			
19	-9.27	-5.77	41	-2.49	-8.18	63	-6.02	-1.22			
20	-10.31	-3.58	42	-4.67	-7.11	64	-6.02	+1.22			
21	-10.85	-1.22	43	-6.55	-5.59	65	-5.28	+3.53			
22	-10.85	+1.22	44	-7.90	-3.58	66	-3.40	+5.05			

21-39

I III

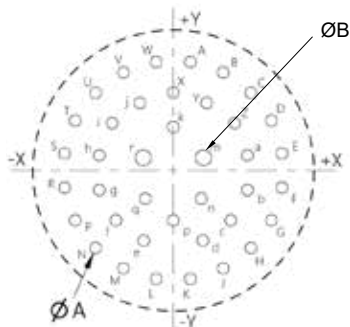

37 contacts size 20
2 contacts size 16

20-39

II

Cavity	X axis	Y axis	Cavity	X axis	Y axis	Cavity	X axis	Y axis
A	+1.65	+10.44	R	-10.44	-1.65	f	-5.51	-4.80
B	+4.80	+9.42	S	-10.44	+1.65	g	-7.11	-1.88
C	+7.47	+7.47	T	-9.42	+4.80	h	-7.11	+1.45
D	+9.42	+4.80	U	-7.47	+7.47	i	-5.89	+4.55
E	+10.44	+1.65	V	-4.80	+9.42	j	-3.20	+6.50
F	+10.44	-1.65	W	-1.65	+10.44	k	0	+4.17
G	+9.42	-4.80	X	0	+7.49	m	+2.90	+1.22
H	+7.47	-7.47	Y	+3.20	+6.50	n	+2.69	-2.72
J	+4.80	-9.42	Z	+5.89	+4.55	p	0	-4.80
K	+1.65	-10.44	a	+7.11	+1.45	q	-2.69	-2.72
L	-1.65	-10.44	b	+7.11	-1.88	r	-2.90	+1.09
M	-4.80	-9.42	c	+5.51	-4.80	Gold contacts		Tinned contacts*
N	-7.47	-7.47	d	+2.84	-6.73	ØA _{MIN}	0.8	0.9
P	-9.42	-4.80	e	-2.84	-6.73	ØB _{MIN}	1.45	1.55

Note: shown in this catalog are the most common insert patterns for PCB applications. For availability of other arrangements, please consult Amphenol Socapex.

HD High density III Series III/TV-CTV II Series II/JT I Series I/LJT

PCB CONTACTS PATTERNS - PCB DRILLINGS

* Tin, tin lead, silver tin or silver tin copper drilling holes are identical.

Front face of pin insert shown.
 $\varnothing A$ & $\varnothing B$: recommended hole diameters, given for CI contacts.

PCB version are not QPL certified.
 Amphenol designation only.

21-41

20-41

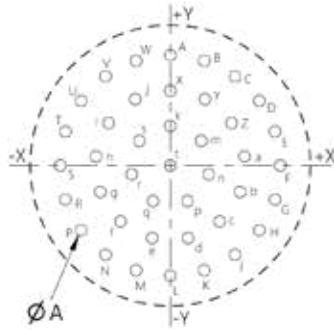

41 contacts size 20

Cavity	X axis	Y axis	Cavity	X axis	Y axis	Cavity	X axis	Y axis	Cavity	X axis	Y axis
A	0	+10.60	M	-3.28	-10.09	Z	+5.92	+4.09	j	-3.35	+6.38
B	+3.28	+10.09	N	-6.23	-8.58	a	+7.15	+0.87	k	0	+3.81
C	+6.23	+8.58	P	-8.58	-6.23	b	+6.73	-2.55	m	+2.98	+2.38
D	+8.58	+6.23	R	-10.09	-3.28	b	+6.73	-2.55	n	+3.71	-0.85
E	+10.09	+3.28	S	-10.60	0	c	+4.78	-5.39	p	+1.66	-3.43
F	+10.60	0	T	-10.09	+3.28	d	+1.73	-6.99	q	-1.66	-3.43
G	+10.09	-3.28	U	-8.58	+6.23	e	-1.73	-6.99	r	-3.71	-0.85
H	+8.58	-6.23	V	-6.23	+8.58	f	-4.78	-5.39	s	-2.98	+2.38
J	+6.23	-8.58	W	-3.28	+10.09	g	-6.73	-2.55	t	0	0
K	+3.28	-10.09	X	0	+7.20	h	-7.15	+0.87		Gold contacts	Tinned contacts*
L	0	-10.60	Y	+3.35	+6.38	i	-5.92	+4.09	$\varnothing A_{MIN}$	1.0	1.1

21-121

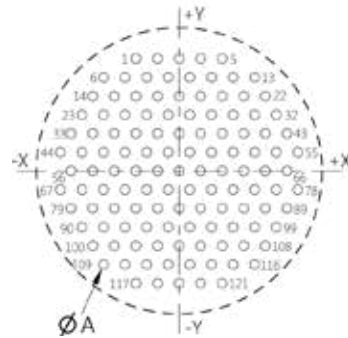

121 contacts size 23

Cavity	X axis	Y axis	Cavity	X axis	Y axis	Cavity	X axis	Y axis	Cavity	X axis	Y axis	Cavity	X axis	Y axis
1	-4.08	+10.60	27	-1.02	+5.30	53	+7.14	+1.77	79	-10.20	-3.53	105	+2.04	-7.07
2	-2.04	+10.60	28	+1.02	+5.30	54	+9.18	+1.77	80	-8.16	-3.53	106	+4.08	-7.07
3	0	+10.60	29	+3.06	+5.30	55	+11.22	+1.77	81	-6.12	-3.53	107	+6.12	-7.07
4	+2.04	+10.60	30	+5.10	+5.30	56	-10.20	0	82	-4.08	-3.53	108	+8.16	-7.07
5	+4.08	+10.60	31	+7.14	+5.30	57	-8.16	0	83	-2.04	-3.53	109	-7.14	-8.83
6	-7.14	+8.83	32	+9.18	+5.30	58	-6.12	0	84	0	-3.53	110	-5.10	-8.83
7	-5.10	+8.83	33	-10.20	+3.53	59	-4.08	0	85	+2.04	-3.53	111	-3.06	-8.83
8	-3.06	+8.83	34	-8.16	+3.53	60	-2.04	0	86	+4.08	-3.53	112	-1.02	-8.83
9	-1.02	+8.83	35	-6.12	+3.53	61	0	0	87	+6.12	-3.53	113	+1.02	-8.83
10	+1.02	+8.83	36	-4.08	+3.53	62	+2.04	0	88	+8.16	-3.53	114	+3.06	-8.83
11	+3.06	+8.83	37	-2.04	+3.53	63	+4.08	0	89	+10.20	-3.53	115	+5.10	-8.83
12	+5.10	+8.83	38	0	+3.53	64	+6.12	0	90	-9.18	-5.30	116	+7.14	-8.83
13	+7.14	+8.83	39	+2.04	+3.53	65	+8.16	0	91	-7.14	-5.30	117	-4.08	-10.60
14	-8.16	+7.07	40	+4.08	+3.53	66	+10.20	0	92	-5.10	-5.30	118	-2.04	-10.60
15	-6.12	+7.07	41	+6.12	+3.53	67	-11.22	-1.77	93	-3.06	-5.30	119	0	-10.60
16	-4.08	+7.07	42	+8.16	+3.53	68	-9.18	-1.77	94	-1.02	-5.30	120	+2.04	-10.60
17	-2.04	+7.07	43	+10.20	+3.53	69	-7.14	-1.77	95	+1.02	-5.30	121	+4.08	-10.60
18	0	+7.07	44	-11.22	+1.77	70	-5.10	-1.77	96	+3.06	-5.30		Gold contacts	Tinned contacts*
19	+2.04	+7.07	45	-9.18	+1.77	71	-3.06	-1.77	97	+5.10	-5.30	$\varnothing A_{MIN}$	0.8	0.9
20	+4.08	+7.07	46	-7.14	+1.77	72	-1.02	-1.77	98	+7.14	-5.30			
21	+6.12	+7.07	47	-5.10	+1.77	73	+1.02	-1.77	99	+9.18	-5.30			
22	+8.16	+7.07	48	-3.06	+1.77	74	+3.06	-1.77	100	-8.16	-7.07			
23	-9.18	+5.30	49	-1.02	+1.77	75	+5.10	-1.77	101	-6.12	-7.07			
24	-7.14	+5.30	50	+1.02	+1.77	76	+7.14	-1.77	102	-4.08	-7.07			
25	-5.10	+5.30	51	+3.06	+1.77	77	+9.18	-1.77	103	-2.04	-7.07			
26	-3.06	+5.30	52	+5.10	+1.77	78	+11.22	-1.77	104	0	-7.07			

Note: shown in this catalog are the most common insert patterns for PCB applications.
 For availability of other arrangements, please consult Amphenol Socapex.

HD High density III Series III/TV-CTV I Series II/JT I Series I/LJT

Due to technical modifications, all information provided is subject to change without prior notice
 Designed by Amphenol Socapex

PCB CONTACTS PATTERNS - PCB DRILLINGS

* Tin, tin lead, silver tin or silver tin copper drilling holes are identical.

Front face of pin insert shown.

ØA & ØB : recommended hole diameters, given for CI contacts.

PCB version are not QPL certified. Amphenol designation only.

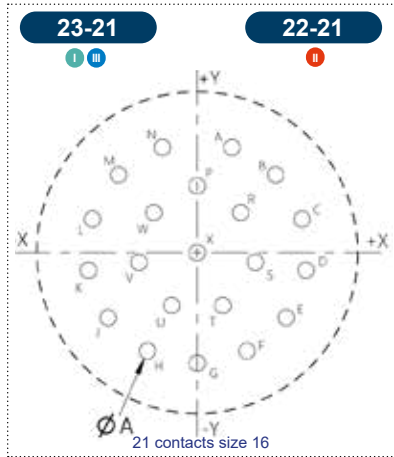

Cavity	X axis	Y axis
A	+3.25	+9.78
B	+7.34	+7.24
C	+9.80	+3.12
D	+10.16	-1.65
E	+8.33	-6.07
F	+4.65	-9.19
G	0	-10.31
H	-4.65	-9.19
J	-8.33	-6.07
K	-10.16	-1.65
L	-9.80	+3.12
M	-7.34	+7.24
N	-3.25	+9.78
P	0	+6.22
R	+4.06	+3.71
S	+5.44	-0.89
T	+2.39	-4.93
U	-2.39	-4.93
V	-5.44	-0.89
W	-4.06	+3.71
X	0	0
	Gold contacts	Tinned contacts*
ØA _{MIN}	1.45	1.55

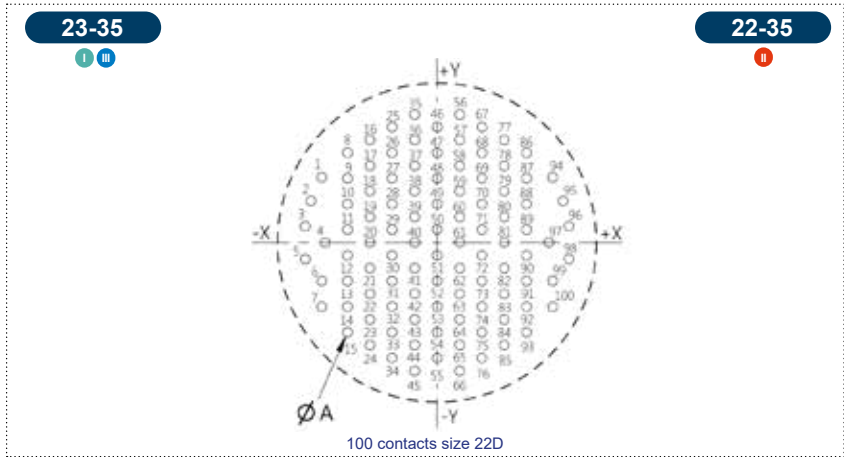

Cavity	X axis	Y axis	Cavity	X axis	Y axis	Cavity	X axis	Y axis
1	-10.87	+6.12	35	-2.11	+12.07	69	+4.22	+6.05
2	-11.86	+3.91	36	-2.11	+9.65	70	+4.22	+3.63
3	-12.40	+1.55	37	-2.11	+7.24	71	+4.22	+1.22
4	-10.54	0	38	-2.11	+4.83	72	+4.22	-1.19
5	-12.40	-1.55	39	-2.11	+2.41	73	+4.22	-3.61
6	-10.87	-3.61	40	-2.11	0	74	+4.22	-6.02
7	-10.87	-6.02	41	-2.11	-2.41	75	+4.22	-8.43
8	-8.43	+8.46	42	-2.11	-4.83	76	+4.22	-10.85
9	-8.43	+6.05	43	-2.11	-7.24	77	+6.32	+9.65
10	-8.43	+3.63	44	-2.11	-9.65	78	+6.32	+7.24
11	-8.43	+1.22	45	-2.11	-12.07	79	+6.32	+4.83
12	-8.43	-1.19	46	0	+10.87	80	+6.32	+2.41
13	-8.43	-3.61	47	0	+8.46	81	+6.32	0
14	-8.43	-6.02	48	0	+6.05	82	+6.32	-2.41
15	-8.43	-8.43	49	0	+3.63	83	+6.32	-4.83
16	-6.32	+9.65	50	0	+1.22	84	+6.32	-7.24
17	-6.32	+7.24	51	0	-1.19	85	+6.32	-9.65
18	-6.32	+4.83	52	0	-3.61	86	+8.43	+8.46
19	-6.32	+2.41	53	0	-6.02	87	+8.43	+6.05
20	-6.32	0	54	0	-8.43	88	+8.43	+3.63
21	-6.32	-2.41	55	0	-10.85	89	+8.43	+1.22
22	-6.32	-4.83	56	+2.11	+12.07	90	+8.43	-1.19
23	-6.32	-7.24	57	+2.11	+9.65	91	+8.43	-3.61
24	-6.32	-9.65	58	+2.11	+7.24	92	+8.43	-6.02
25	-4.22	+10.87	59	+2.11	+4.83	93	+8.43	-8.43
26	-4.22	+8.46	60	+2.11	+2.41	94	+10.87	+6.12
27	-4.22	+6.05	61	+2.11	0	95	+11.86	+3.91
28	-4.22	+3.63	62	+2.11	-2.41	96	+12.40	+1.55
29	-4.22	+1.22	63	+2.11	-4.83	97	+10.54	0
30	-4.22	-1.19	64	+2.11	-7.24	98	+12.40	-1.55
31	-4.22	-3.61	65	+2.11	-9.65	99	+10.87	-3.61
32	-4.22	-6.02	66	+2.11	-12.07	100	+10.87	-6.02
33	-4.22	-8.43	67	+4.22	+10.87		Gold contacts	Tinned contacts*
34	-4.22	-10.85	68	+4.22	+8.46	ØA _{MIN}	0.8	0.9

22
23

Note: shown in this catalog are the most common insert patterns for PCB applications. For availability of other arrangements, please consult Amphenol Socapex.

HD High density III Series III/TV-CTV II Series II/JT I Series I/LJT

Due to technical modifications, all information provided is subject to change without prior notice. Designed by Amphenol Socapex

PCB CONTACTS PATTERNS - PCB DRILLINGS

* Tin, tin lead, silver tin or silver tin copper drilling holes are identical.

PCB version are not QPL certified. Amphenol designation only.

Front face of pin insert shown.
 $\varnothing A$ & $\varnothing B$: recommended hole diameters, given for CI contacts.

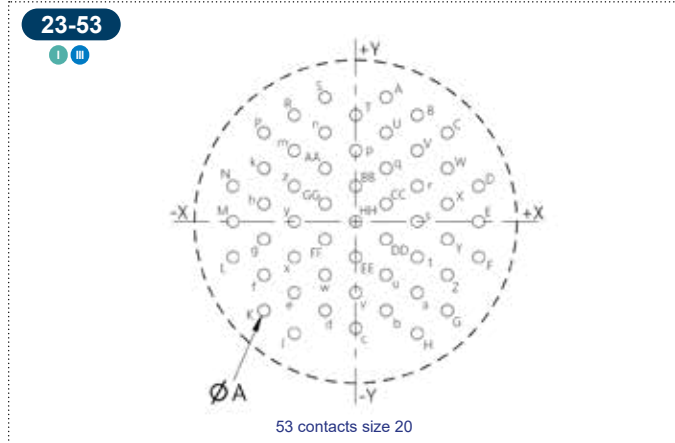

Cavity	X axis	Y axis	Cavity	X axis	Y axis
A	+2.84	+11.56	f	-8.53	-4.95
B	+5.72	+9.91	g	-8.53	-1.65
C	+8.53	+8.26	h	-8.53	+1.65
D	+11.43	+3.30	k	-8.53	+4.95
E	+11.43	0	m	-5.72	+6.60
F	+11.43	-3.30	n	-2.84	+8.26
G	+8.53	-8.26	p	0	+6.60
H	+5.72	-10.41	q	+2.84	+4.95
J	-5.72	-10.41	r	+5.72	+3.30
K	-8.53	-8.26	s	+5.72	0
L	-11.43	-3.30	t	+5.72	-3.30
M	-11.43	0	u	+2.84	-4.95
N	-11.43	+3.30	v	0	-6.60
P	-8.53	+8.26	w	-2.84	-4.95
R	-5.72	+9.91	x	-5.72	-3.30
S	-2.84	+11.56	y	-5.72	0
T	0	+9.91	z	-5.72	+3.30
U	+2.84	+8.26	AA	-2.84	+4.95
V	+5.72	+6.60	BB	0	+3.30
W	+8.53	+4.95	CC	+2.84	+1.65
X	+8.53	+1.65	DD	+2.84	-1.65
Y	+8.53	-1.65	EE	0	-3.30
Z	+8.53	-4.95	FF	-2.84	-1.65
a	+5.72	-6.60	GG	-2.84	+1.65
b	+2.84	-8.26	HH	0	0
c	0	-9.91			
d	-2.84	-8.26			
e	-5.72	-6.60			
				Gold contacts	Tinned contacts*
			$\varnothing A_{MIN}$	1.0	1.1

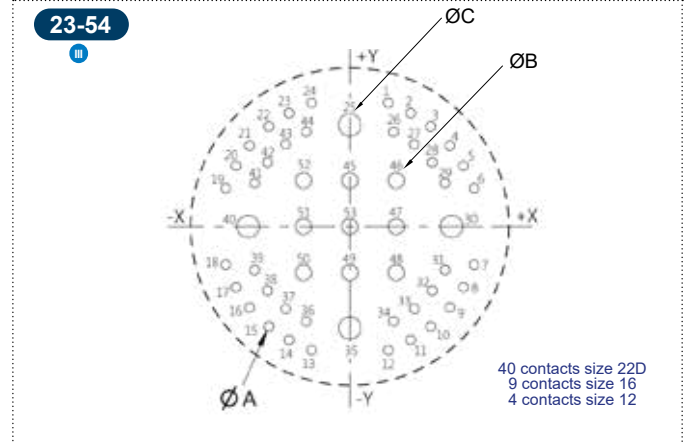

Cavity	X axis	Y axis	Cavity	X axis	Y axis
1	+3.61	+11.71	30	+9.60	0
2	+5.74	+10.72	31	+8.97	-4.11
3	+7.65	+9.45	32	+7.77	-6.07
4	+9.45	+7.65	33	+6.07	-7.77
5	+10.72	+5.74	34	+4.11	-8.97
6	+11.71	+3.61	35	0	-9.60
7	+11.71	-3.61	36	-4.11	-8.97
8	+10.72	-5.74	37	-6.07	-7.77
9	+9.45	-7.65	38	-7.77	-6.07
10	+7.65	-9.45	39	-8.97	-4.11
11	+5.74	-10.72	40	-9.60	0
12	+3.61	-11.71	41	-8.97	+4.11
13	-3.61	-11.71	42	-7.77	+6.07
14	-5.74	-10.72	43	-6.07	+7.77
15	-7.65	-9.45	44	-4.11	+8.97
16	-9.45	-7.65	45	0	+4.37
17	-10.72	-5.74	46	+4.37	+4.37
18	-11.71	-3.61	47	+4.37	0
19	-11.71	+3.61	48	+4.37	-4.37
20	-10.72	+5.74	49	0	-4.37
21	-9.45	+7.65	50	-4.37	-4.37
22	-7.65	+9.45	51	-4.37	0
23	-5.74	+10.72	52	-4.37	+4.37
24	-3.61	+11.71	53	0	0
25	0	+9.60		Gold contacts	Tinned contacts*
26	+4.11	+8.97	$\varnothing A_{MIN}$	0.8	0.9
27	+6.07	+7.77	$\varnothing B_{MIN}$	1.45	1.55
28	+7.77	+6.07	$\varnothing C_{MIN}$	2.0	2.1
29	+8.97	+4.11			

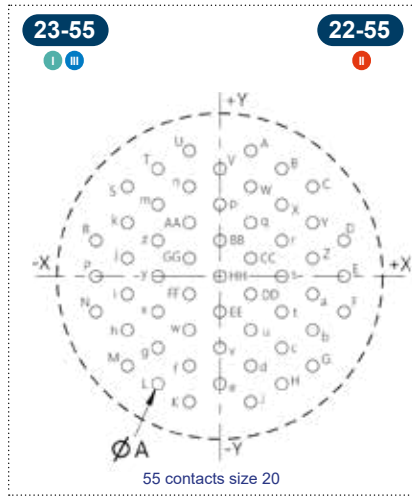

Cavity	X axis	Y axis
A	+2.84	+11.56
B	+5.72	+9.91
C	+8.53	+8.26
D	+11.43	+3.30
E	+11.43	0
F	+11.43	-3.30
G	+8.53	-8.26
H	+5.72	-9.91
J	+2.84	-11.56
K	-2.84	-11.56
L	-5.72	-9.91
M	-8.53	-8.26
N	-11.43	-3.30
P	-11.43	0
R	-11.43	+3.30
S	-8.53	+8.26
T	-5.72	+9.91
U	-2.84	+11.56
V	0	+9.91
W	+2.84	+8.26
X	+5.72	+6.60

Cavity	X axis	Y axis
Y	+8.53	+4.95
Z	+8.53	+1.65
a	+8.53	-1.65
b	+8.53	-4.95
c	+5.72	-6.60
d	+2.84	-8.26
e	0	-9.91
f	-2.84	-8.26
g	-5.72	-6.60
h	-8.53	-4.95
i	-8.53	-1.65
j	-8.53	+1.65
k	-8.53	+4.95
m	-5.72	+6.60
n	-2.84	+8.26
p	0	+6.60
q	+2.84	+4.95
r	+5.72	+3.30
s	+5.72	0
t	+5.72	-3.30
u	+2.84	-4.95

Cavity	X axis	Y axis
v	0	-6.60
w	-2.84	-4.95
x	-5.72	-3.30
y	-5.72	0
z	-5.72	+3.30
AA	-2.84	+4.95
BB	0	+3.30
CC	+2.84	+1.65
DD	+2.84	-1.65
EE	0	-3.30
FF	-2.84	-1.65
GG	-2.84	+1.65
HH	0	0
	Gold contacts	Tinned contacts*
$\varnothing A_{MIN}$	1.0	1.1

Note: shown in this catalog are the most common insert patterns for PCB applications. For availability of other arrangements, please consult Amphenol Socapex.

HD High density III Series III/TV-CTV II Series II/JT I Series I/LJT

PCB CONTACTS PATTERNS - PCB DRILLINGS

* Tin, tin lead, silver tin or silver tin copper drilling holes are identical.

Front face of pin insert shown.

ØA, ØB & ØC : recommended hole diameters, given for CI contacts.

PCB version are not QPL certified. Amphenol designation only.

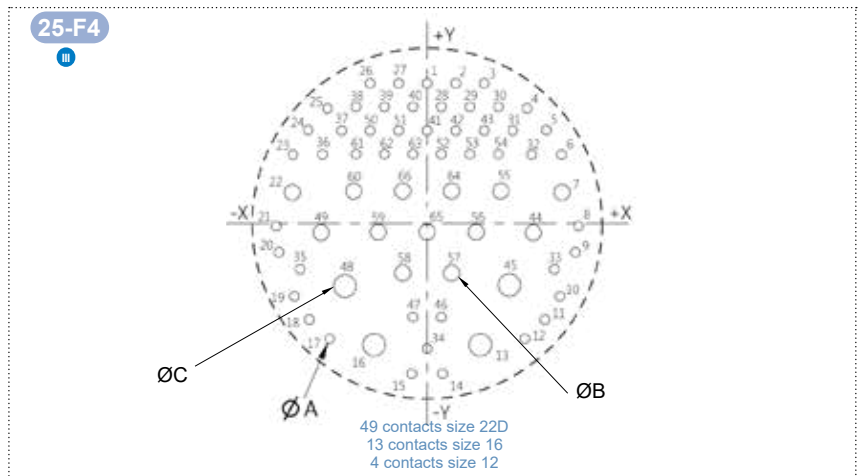
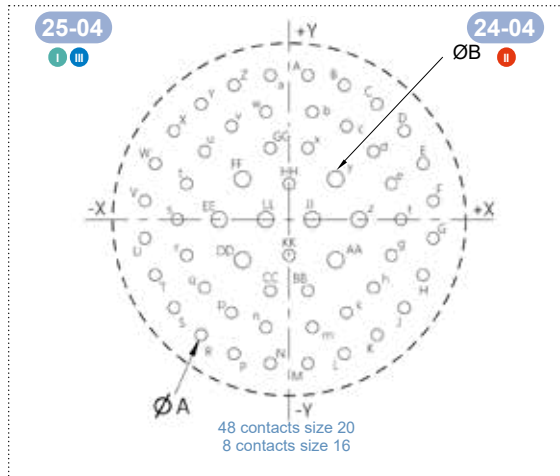

Cavity	X axis	Y axis	Cavity	X axis	Y axis
A	+1.75	+13.49	f	+10.46	0
B	+5.16	+12.57	g	+9.58	-3.35
C	+8.23	+10.80	h	+7.90	-6.38
D	+10.77	+8.28	k	+5.38	-8.74
E	+12.52	+5.21	m	+2.18	-10.08
F	+13.49	+1.75	n	-2.18	-10.08
G	+13.49	-1.75	p	-5.38	-8.74
H	+12.52	-5.21	q	-7.90	-6.38
J	+10.77	-8.28	r	-9.58	-3.35
K	+8.23	-10.80	s	-10.46	0
L	+5.16	-12.57	t	-9.58	+3.35
M	+1.75	-13.49	u	-7.90	+6.38
N	-1.75	-13.49	v	-5.38	+8.74
P	-5.16	-12.57	w	-2.18	+10.08
R	-8.23	-10.80	x	+1.75	+6.68
S	-10.77	-8.28	y	+4.37	+3.78
T	-12.52	-5.21	z	+6.55	0
U	-13.49	-1.75	AA	+4.37	-3.78
V	-13.49	+1.75	BB	+1.75	-6.68
W	-12.52	+5.21	CC	-1.75	-6.68
X	-10.77	+8.28	DD	-4.37	-3.78
Y	-8.23	+10.80	EE	-6.55	0
Z	-5.16	+12.57	FF	-4.37	+3.78
a	-1.75	+13.49	GG	-1.75	+6.68
b	+2.18	+10.08	HH	0	+3.35
c	+5.38	+8.74	JJ	+2.18	0
d	+7.90	+6.38	KK	0	-3.35
e	+9.58	+3.35	LL	-2.18	0
		Gold contacts		Tinned contacts*	
ØA _{MIN}		1.0		1.1	
ØB _{MIN}		1.45		1.55	

Cavity	X axis	Y axis	Cavity	X axis	Y axis	Cavity	X axis	Y axis
1	0	+13.18	24	-11.23	+8.79	47	-1.35	-8.81
2	+2.69	+13.18	25	-9.42	+10.82	48	-7.75	-5.89
3	+5.38	+13.18	26	-5.38	+13.18	49	-10.01	-0.86
4	+9.42	+10.82	27	-2.69	+13.18	50	-5.38	+8.74
5	+11.23	+8.79	28	+1.35	+10.97	51	-2.69	+8.74
6	+12.67	+6.48	29	+4.04	+10.97	52	+1.35	+6.53
7	+12.73	+2.92	30	+6.73	+10.97	53	+4.04	+6.53
8	+14.27	-0.25	31	+8.08	+8.74	54	+6.73	+6.53
9	+13.97	-2.72	32	+9.86	+6.48	55	+6.93	+3.05
10	+12.52	-6.86	33	+11.99	-4.32	56	+4.62	-0.81
11	+11.10	-9.07	34	0	-11.79	57	+2.31	-4.67
12	+9.19	-10.87	35	-11.99	-4.32	58	-2.31	-4.67
13	+5.00	-11.43	36	-9.86	+6.48	59	-4.62	-0.81
14	+1.45	-14.15	37	-8.08	+8.74	60	-6.93	+3.05
15	-1.45	-14.15	38	-6.73	+10.97	61	-6.73	+6.53
16	-5.00	-11.43	39	-4.04	+10.97	62	-4.04	+6.53
17	-9.19	-10.87	40	-1.35	+10.97	63	-1.35	+6.53
18	-11.10	-9.07	41	0	+8.74	64	+2.31	+3.05
19	-12.52	-6.86	42	+2.69	+8.74	65	0	-0.81
20	-13.97	-2.72	43	+5.38	+8.74	66	-2.31	+3.05
21	-14.27	-0.25	44	+10.01	-0.86	Gold contacts		Tinned contacts*
22	-12.73	+2.92	45	+7.75	-5.89	ØA _{MIN}	0.8	0.9
23	-12.67	+6.48	46	+1.35	-8.81	ØB _{MIN}	1.45	1.55
						ØC _{MIN}	2.0	2.1

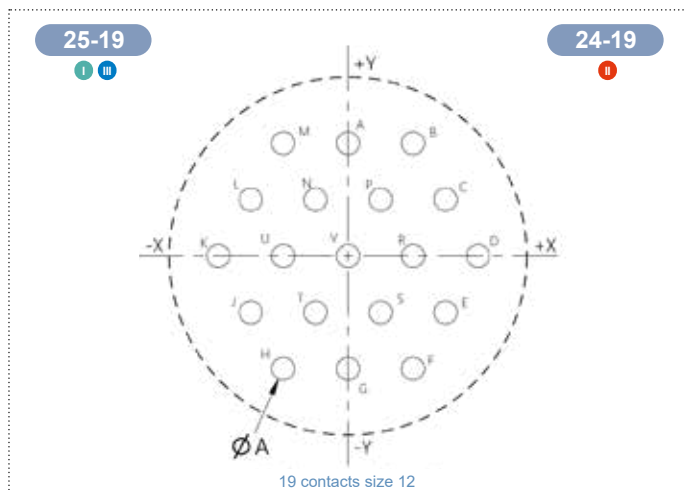

Cavity	X axis	Y axis	Gold contacts		Tinned contacts*	
A	0	+10.39	ØA _{MIN}	2.0	2.1	
B	+5.99	+10.39				
C	+8.99	+5.21				
D	+11.99	0				
E	+8.99	-5.21				
F	+5.99	-10.39				
G	0	-10.39				
H	-5.99	-10.39				
J	-8.99	-5.21				
K	-11.99	0				
L	-8.99	+5.21				
M	-5.99	+10.39				
N	-3.00	+5.21				
P	+3.00	+5.21				
R	+5.99	0				
S	+3.00	-5.21				
T	-3.00	-5.21				
U	-5.99	0				
V	0	0				

Note: shown in this catalog are the most common insert patterns for PCB applications. For availability of other arrangements, please consult Amphenol Socapex.

HD High density III Series III/TV-CTV II Series II/JT I Series I/LJT

PCB CONTACTS PATTERNS - PCB DRILLINGS

* Tin, tin lead, silver tin or silver tin copper drilling holes are identical.

PCB version are not QPL certified. Amphenol designation only.

Front face of pin insert shown.

ØA & ØB : recommended hole diameters, given for CI contacts.

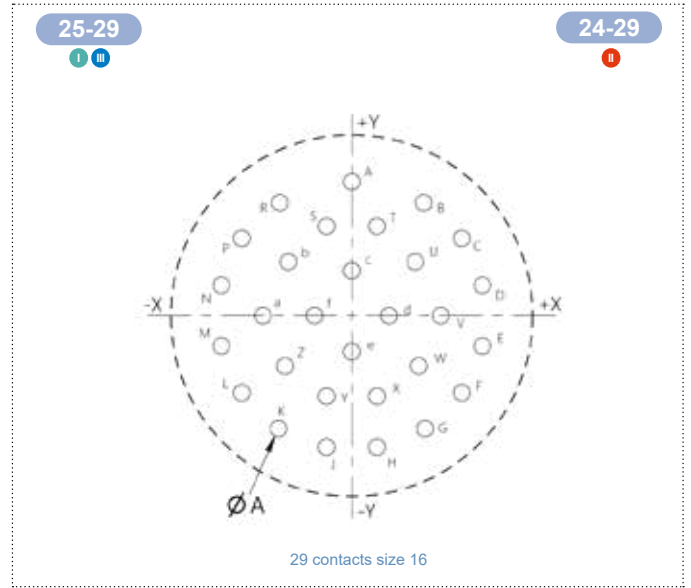
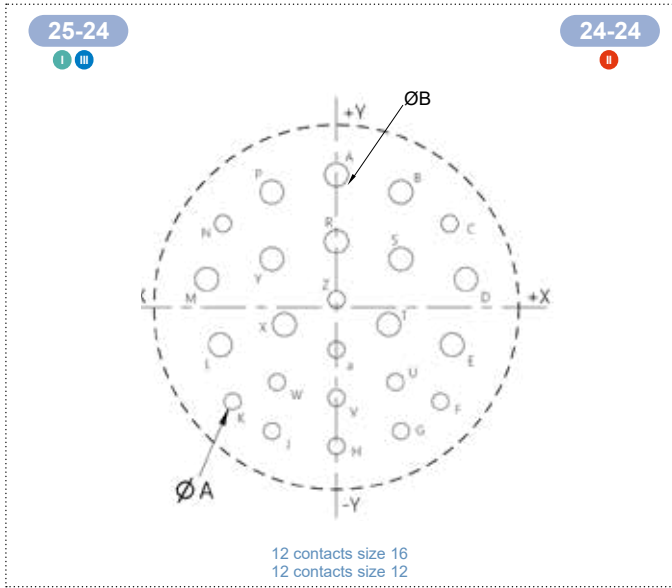

Cavity	X axis	Y axis
A	0	+11.99
B	+5.84	+10.41
C	+10.24	+7.57
D	+11.71	+2.54
E	+10.49	-3.40
F	+9.40	-8.53
G	+5.84	-11.20
H	0	-12.57
J	-5.84	-11.20
K	-9.40	-8.53
L	-10.49	-3.40
M	-11.71	+2.54
N	-10.24	+7.57
P	-5.84	+10.41
R	0	+5.94
S	+5.84	+4.37
T	+4.72	-1.57
U	+5.36	-6.78
V	0	-8.20
W	-5.36	-6.78
X	-4.72	-1.57
Y	-5.84	+4.37
Z	0	+0.71
a	0	-3.84
	Gold contacts	Tinned contacts*
ØA _{MIN}	1.45	1.55
ØB _{MIN}	2.0	2.1

Cavity	X axis	Y axis
A	0	+12.22
B	+6.55	+10.31
C	+10.03	+7.04
D	+11.91	+2.77
E	+11.91	-2.77
F	+10.03	-7.04
G	+6.68	-10.31
H	+2.31	-11.99
J	-2.31	-11.99
K	-6.68	-10.31
L	-10.03	-7.04
M	-11.91	-2.77
N	-11.91	+2.77
P	-10.03	+7.04
R	-6.55	+10.31
S	-2.31	+8.15
T	+2.31	+8.15
U	+5.79	+4.93
V	+8.10	0
W	+6.10	-4.60
X	+2.31	-7.37
Y	-2.31	-7.37
Z	-6.10	-4.60
a	-8.10	0
b	-5.79	+4.93
c	0	+4.09
d	+3.40	0
e	0	-3.30
f	-3.40	0
	Gold contacts	Tinned contacts*
ØA _{MIN}	1.45	1.55

24
25

Note: shown in this catalog are the most common insert patterns for PCB applications. For availability of other arrangements, please consult Amphenol Socapex.

HD High density III Series III/TV-CTV II Series II/JT I Series I/LJT

Due to technical modifications, all information provided is subject to change without prior notice. Designed by Amphenol Socapex

PCB CONTACTS PATTERNS - PCB DRILLINGS

* Tin, tin lead, silver tin or silver tin copper drilling holes are identical.

PCB version are not QPL certified. Amphenol designation only.

Front face of pin insert shown.

ØA & ØB : recommended hole diameters, given for CI contacts.

25-35

I III

24-35

I

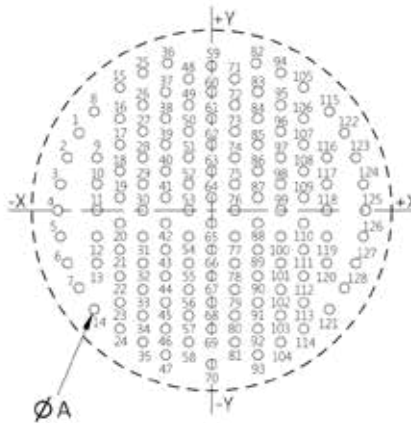

128 contacts size 22D

Cavity	X axis	Y axis	Cavity	X axis	Y axis	Cavity	X axis	Y axis	Cavity	X axis	Y axis	Cavity	X axis	Y axis
1	-12.17	+7.09	27	-6.32	+7.24	53	-2.11	0	79	+2.11	-7.24	105	+8.43	+11.28
2	-13.21	+4.83	28	-6.32	+4.83	54	-2.11	-2.41	80	+2.11	-9.65	106	+8.43	+8.43
3	-13.87	+2.41	29	-6.32	+2.41	55	-2.11	-4.83	81	+2.11	-12.07	107	+8.43	+6.02
4	-14.10	0	30	-6.32	0	56	-2.11	-7.24	82	+4.06	+13.49	108	+8.43	+3.61
5	-13.87	-2.41	31	-6.32	-2.41	57	-2.11	-9.65	83	+4.22	+10.85	109	+8.43	+1.19
6	-13.21	-4.83	32	-6.32	-4.83	58	-2.11	-12.07	84	+4.22	+8.43	110	+8.43	-1.19
7	-12.17	-7.09	33	-6.32	-7.24	59	0	+13.26	85	+4.22	+6.02	111	+8.43	-3.61
8	-10.77	+9.07	34	-6.32	-9.65	60	0	+10.85	86	+4.22	+3.61	112	+8.43	-6.02
9	-10.54	+4.83	35	-6.32	-12.07	61	0	+8.43	87	+4.22	+1.19	113	+8.43	-8.43
10	-10.54	+2.41	36	-4.06	+13.49	62	0	+6.02	88	+4.22	-1.19	114	+8.43	-10.85
11	-10.54	0	37	-4.22	+10.85	63	0	+3.61	89	+4.22	-3.61	115	+10.77	+9.07
12	-10.54	-2.41	38	-4.22	+8.43	64	0	+1.19	90	+4.22	-6.02	116	+10.54	+4.83
13	-10.54	-4.83	39	-4.22	+6.02	65	0	-1.19	91	+4.22	-8.43	117	+10.54	+2.41
14	-10.77	-9.07	40	-4.22	+3.61	66	0	-3.61	92	+4.22	-10.85	118	+10.54	0
15	-8.43	+11.28	41	-4.22	+1.19	67	0	-6.02	93	+4.22	-13.26	119	+10.54	-2.41
16	-8.43	+8.43	42	-4.22	-1.19	68	0	-8.43	94	+6.32	+12.60	120	+10.54	-4.83
17	-8.43	+6.02	43	-4.22	-3.61	69	0	-10.85	95	+6.32	+9.65	121	+10.77	-9.07
18	-8.43	+3.61	44	-4.22	-6.02	70	0	-14.10	96	+6.32	+7.24	122	+12.17	+7.09
19	-8.43	+1.19	45	-4.22	-8.43	71	+2.11	+12.07	97	+6.32	+4.83	123	+13.21	+4.83
20	-8.43	-1.19	46	-4.22	-10.85	72	+2.11	+9.65	98	+6.32	+2.41	124	+13.87	+2.41
21	-8.43	-3.61	47	-4.22	-13.26	73	+2.11	+7.24	99	+6.32	0	125	+14.10	0
22	-8.43	-6.02	48	-2.11	+12.07	74	+2.11	+4.83	100	+6.32	-2.41	126	+13.87	-2.41
23	-8.43	-8.43	49	-2.11	+9.65	75	+2.11	+2.41	101	+6.32	-4.83	127	+13.21	-4.83
24	-8.43	-10.85	50	-2.11	+7.24	76	+2.11	0	102	+6.32	-7.24	128	+12.17	-7.09
25	-6.32	+12.60	51	-2.11	+4.83	77	+2.11	-2.41	103	+6.32	-9.65		Gold contacts	Tinned contacts*
26	-6.32	+9.65	52	-2.11	+2.41	78	+2.11	-4.83	104	+6.32	-12.07	ØA _{MIN}	0.8	0.9

24
25

Note: shown in this catalog are the most common insert patterns for PCB applications. For availability of other arrangements, please consult Amphenol Socapex.

HD High density III Series III/TV-CTV I Series II/JT I Series I/LJT

PCB CONTACTS PATTERNS - PCB DRILLINGS

* Tin, tin lead, silver tin or silver tin copper drilling holes are identical.

PCB version are not QPL certified. Amphenol designation only.

Front face of pin insert shown.

ØA & ØB : recommended hole diameters, given for CI contacts.

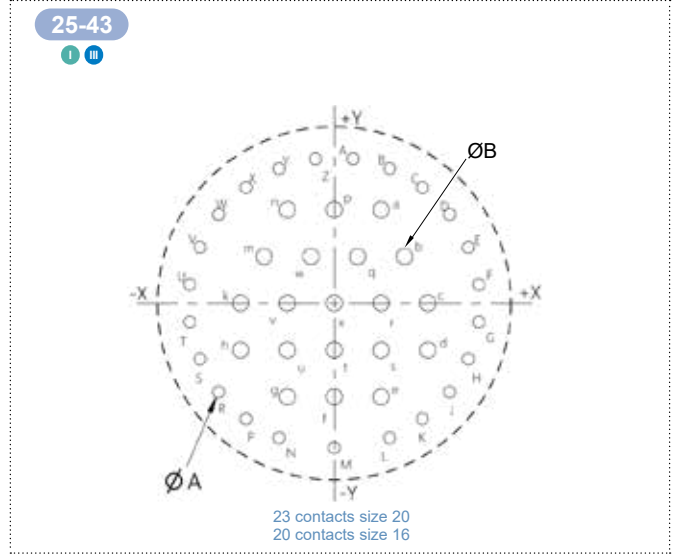
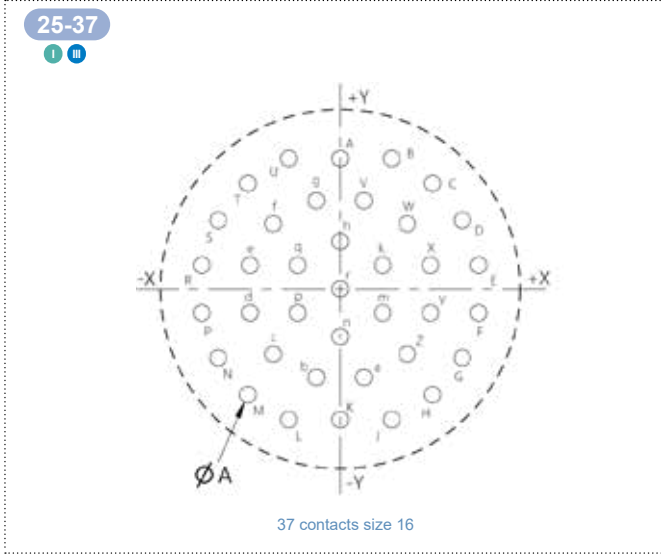

Cavity	X axis	Y axis
A	0	+11.99
B	+4.70	+11.99
C	+8.46	+9.70
D	+11.20	+6.32
E	+12.70	+2.18
F	+12.70	-2.18
G	+11.20	-6.32
H	+8.46	+9.70
J	+4.72	-11.99
K	0	-11.99
L	-4.72	-11.99
M	-8.46	-9.70
N	-11.20	-6.32
P	-12.70	-2.18
R	-12.70	+2.18
S	-11.20	+6.32
T	-8.46	+9.70
U	-4.72	+11.99
V	+2.18	+8.13
W	+6.15	+5.99
X	+8.28	+2.18
Y	+8.28	-2.18
Z	+6.15	-5.99
a	+2.18	-8.13
b	-2.18	-8.13
c	-6.15	-5.99
d	-8.28	-2.18
e	-8.28	+2.18
f	-6.15	+5.99
g	-2.18	+8.13
h	0	+4.37
k	+3.91	+2.18
m	+3.91	-2.18
n	0	-4.37
p	-3.91	-2.18
q	-3.91	+2.18
r	0	0
	Gold contacts	Tinned contacts*
ØA _{MIN}	1.45	1.55

Cavity	X axis	Y axis
A	+1.75	+13.49
B	+5.16	+12.57
C	+8.23	+10.80
D	+10.77	+8.28
E	+12.52	+5.21
F	+13.49	+1.75
G	+13.49	-1.75
H	+12.52	-5.21
J	+10.77	-8.28
K	+8.23	-10.80
L	+5.16	-12.57
M	0	-13.49
N	-5.16	-12.57
P	-8.23	-10.80
R	-10.77	-8.28
S	-12.52	-5.21
T	-13.49	-1.75
U	-13.49	+1.75
V	-12.52	+5.21
W	-10.77	+8.28
X	-8.23	+10.80
Y	-5.16	+12.57
Z	-1.75	+13.49
a	+4.37	+8.74
b	+6.55	+4.37
c	+8.74	0
d	+8.74	-4.37
e	+4.37	-8.74
f	0	-8.74
g	-4.37	-8.74
h	-8.74	-4.37
k	-8.74	0
m	-6.55	+4.37
n	-4.37	+8.74
p	0	+8.74
q	+2.18	+4.37
r	+4.37	0
s	+4.37	-4.37
t	0	-4.37
u	-4.37	-4.37
v	-4.37	0
w	-2.18	+4.37
x	0	0
	Gold contacts	Tinned contacts*
ØA _{MIN}	1.0	1.1
ØB _{MIN}	1.45	1.55

Note: shown in this catalog are the most common insert patterns for PCB applications. For availability of other arrangements, please consult Amphenol Socapex.

HD High density III Series III/TV-CTV II Series II/JT I Series I/LJT

Due to technical modifications, all information provided is subject to change without prior notice. Designed by Amphenol Socapex

PCB CONTACTS PATTERNS - PCB DRILLINGS

* Tin, tin lead, silver tin or silver tin copper drilling holes are identical.

PCB version are not QPL certified. Amphenol designation only.

Front face of pin insert shown.
 $\varnothing A$ & $\varnothing B$: recommended hole diameters, given for CI contacts.

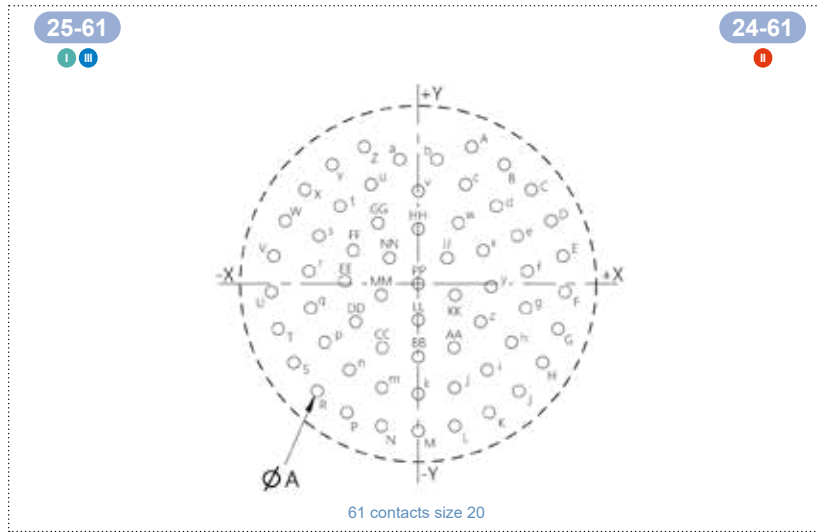

61 contacts size 20

Cavity	X axis	Y axis	Cavity	X axis	Y axis
A	+4.98	+12.70	h	+8.66	-5.41
B	+7.98	+11.05	i	+6.38	-7.98
C	+10.49	+8.71	j	+3.38	-9.63
D	+12.32	+5.84	k	0	-10.21
E	+13.39	+2.57	m	-3.38	-9.63
F	+13.61	-0.76	n	-6.38	-7.98
G	+12.98	-4.17	p	-8.66	-5.41
H	+11.53	-7.29	q	-9.96	-2.24
J	+9.35	-9.93	r	-10.13	+1.17
K	+6.58	-11.94	s	-9.19	+4.45
L	+3.40	-13.18	t	-7.24	+7.19
M	0	-13.64	u	-4.39	+9.22
N	-3.40	-13.18	v	0	+8.59
P	-6.58	-11.94	w	+3.73	+5.66
R	-9.35	-9.93	x	+6.02	+3.10
S	-11.53	-7.29	y	+6.78	-0.25
T	-12.98	-4.17	z	+5.79	-3.53
U	-13.61	-0.76	AA	+3.33	-5.92
V	-13.39	+2.57	BB	0	-6.78
W	-12.32	+5.84	CC	-3.33	-5.92
X	-10.49	+8.71	DD	-5.79	-3.53
Y	-7.98	+11.05	EE	-6.78	-0.25
Z	-4.98	+12.70	FF	-6.02	+3.10
a	-1.73	+11.53	GG	-3.73	+5.66
b	+1.73	+11.53	HH	0	+5.08
c	+4.39	+9.22	JJ	+2.67	+2.39
d	+7.24	+7.19	KK	+3.43	-1.04
e	+9.19	+4.45	LL	0	-3.35
f	+10.13	+1.17	MM	-3.43	-1.04
g	+9.96	-2.24	NN	-2.67	+2.39
			PP	0	0
			Gold contacts	Tinned contacts*	
			$\varnothing A_{MIN}$	1.0	1.1

24
25

Note: shown in this catalog are the most common insert patterns for PCB applications. For availability of other arrangements, please consult Amphenol Socapex.

HD High density III Series III/TV-CTV II Series II/JT I Series I/LJT

PCB CONTACTS PATTERNS - PCB DRILLINGS

* Tin, tin lead, silver tin or silver tin copper drilling holes are identical.

PCB version are not QPL certified. Amphenol designation only.

Front face of pin insert shown.
 $\varnothing A$ & $\varnothing B$: recommended hole diameters, given for CI contacts.

25-187

HD III

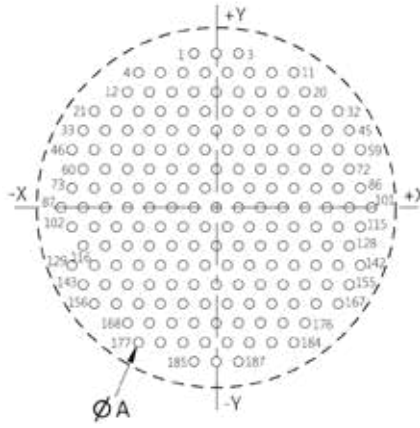

187 contacts size 23

Cavity	X axis	Y axis	Cavity	X axis	Y axis	Cavity	X axis	Y axis	Cavity	X axis	Y axis	Cavity	X axis	Y axis
1	-2.04	+14.13	38	-2.04	+7.07	75	-9.18	+1.77	112	+7.14	-1.77	151	+4.08	-7.07
2	0	+14.13	39	0	+7.07	76	-7.14	+1.77	113	+9.18	-1.77	152	+6.12	-7.07
3	+2.04	+14.13	40	+2.04	+7.07	77	-5.10	+1.77	114	+11.22	-1.77	153	+8.16	-7.07
4	-7.14	+12.37	41	+4.08	+7.07	78	-3.06	+1.77	115	+13.26	-1.77	154	+10.20	-7.07
5	-5.10	+12.37	42	+6.12	+7.07	79	-1.02	+1.77	116	-12.24	-3.53	155	+12.24	-7.07
6	-3.06	+12.37	43	+8.16	+7.07	80	+1.02	+1.77	117	-10.20	-3.53	156	-11.22	-8.83
7	-1.02	+12.37	44	+10.20	+7.07	81	+3.06	+1.77	118	-8.16	-3.53	157	-9.18	-8.83
8	+1.02	+12.37	45	+12.24	+7.07	82	+5.10	+1.77	119	-6.12	-3.53	158	-7.14	-8.83
9	+3.06	+12.37	46	-13.26	+5.30	83	+7.14	+1.77	120	-4.08	-3.53	159	-5.10	-8.83
10	+5.10	+12.37	47	-11.22	+5.30	84	+9.18	+1.77	121	-2.04	-3.53	160	-3.06	-8.83
11	+7.14	+12.37	48	-9.18	+5.30	85	+11.22	+1.77	122	0	-3.53	161	-1.02	-8.83
12	-8.16	+10.60	49	-7.14	+5.30	86	+13.26	+1.77	123	+2.04	-3.53	162	+1.02	-8.83
13	-6.12	+10.60	50	-5.10	+5.30	87	-14.28	0	124	+4.08	-3.53	163	+3.06	-8.83
14	-4.08	+10.60	51	-3.06	+5.30	88	-12.24	0	125	+6.12	-3.53	164	+5.10	-8.83
15	-2.04	+10.60	52	-1.02	+5.30	89	-10.20	0	126	+8.16	-3.53	165	+7.14	-8.83
16	0	+10.60	53	+1.02	+5.30	90	-8.16	0	127	+10.20	-3.53	166	+9.18	-8.83
17	+2.04	+10.60	54	+3.06	+5.30	91	-6.12	0	128	+12.24	-3.53	167	+11.22	-8.83
18	+4.08	+10.60	55	+5.10	+5.30	92	-4.08	0	129	-13.26	-5.30	168	-8.16	-10.60
19	+6.12	+10.60	56	+7.14	+5.30	93	-2.04	0	130	-11.22	-5.30	169	-6.12	-10.60
20	+8.16	+10.60	57	+9.18	+5.30	94	0	0	131	-9.18	-5.30	170	-4.08	-10.60
21	-11.22	+8.83	58	+11.22	+5.30	95	+2.04	0	132	-7.14	-5.30	171	-2.04	-10.60
22	-9.18	+8.83	59	+13.26	+5.30	96	+4.08	0	133	-5.10	-5.30	172	0	-10.60
23	-7.14	+8.83	60	-12.24	+3.53	97	+6.12	0	134	-3.06	-5.30	173	+2.04	-10.60
24	-5.10	+8.83	61	-10.20	+3.53	98	+8.16	0	135	-1.02	-5.30	174	+4.08	-10.60
25	-3.06	+8.83	62	-8.16	+3.53	99	+10.20	0	136	+1.02	-5.30	175	+6.12	-10.60
26	-1.02	+8.83	63	-6.12	+3.53	100	+12.24	0	137	+3.06	-5.30	176	+8.16	-10.60
27	+1.02	+8.83	64	-4.08	+3.53	101	+14.28	0	138	+5.10	-5.30	177	-7.14	-12.37
28	+3.06	+8.83	65	-2.04	+3.53	102	-13.26	-1.77	139	+7.14	-5.30	178	-5.10	-12.37
29	+5.10	+8.83	66	0	+3.53	103	-11.22	-1.77	140	+9.18	-5.30	179	-3.06	-12.37
30	+7.14	+8.83	67	+2.04	+3.53	104	-9.18	-1.77	141	+11.22	-5.30	180	-1.02	-12.37
31	+9.18	+8.83	68	+4.08	+3.53	105	-7.14	-1.77	142	+13.26	-5.30	181	+1.02	-12.37
32	+11.22	+8.83	69	+6.12	+3.53	106	-5.10	-1.77	143	-12.24	-7.07	182	+3.06	-12.37
33	-12.24	+7.07	70	+8.16	+3.53	107	-3.06	-1.77	144	-10.20	-7.07	183	+5.10	-12.37
34	-10.20	+7.07	71	+10.20	+3.53	108	-1.02	-1.77	145	-8.16	-7.07	184	+7.14	-12.37
35	-8.16	+7.07	72	+12.24	+3.53	109	+1.02	-1.77	146	-6.12	-7.07	185	-2.04	-14.13
36	-6.12	+7.07	73	-13.26	+1.77	110	+3.06	-1.77	147	-4.08	-7.07	186	0	-14.13
37	-4.08	+7.07	74	-11.22	+1.77	111	+5.10	-1.77	148	-2.04	-7.07	187	+2.04	-14.13
									149	0	-7.07			
									150	+2.04	-7.07			
												Gold contacts	Tinned contacts*	
												$\varnothing A_{MIN}$	0.8	0.9

24
25

Note: shown in this catalog are the most common insert patterns for PCB applications. For availability of other arrangements, please consult Amphenol Socapex.

HD High density III Series III/TV-CTV II Series II/JT I Series I/LJT

Due to technical modifications, all information provided is subject to change without prior notice. Designed by Amphenol Socapex



MIL-DTL-38999 SERIES III & EN3645, TV / CTV - STANDARD RANGE



Table of contents

MIL-DTL-38999 Series III & EN3645, TV / CTV - STANDARD RANGE		51
General characteristics		52
Mechanical characteristics		53
Environmental characteristics		54
Electrical characteristics		55
Metal shells - TV Series (MIL-DTL-38999/20/24/26 - EN3645)		56
Composite shells - CTV Series (MIL-DTL-38999/20/24/26 - EN3645)		67
Metal & Composite shells weights (MIL-DTL-38999/20/24/26 - EN3645)		64
Hermetic receptacles (MIL-DTL-38999/21/23/25) TV		68
Lanyard release plugs (MIL-DTL-38999/29/30/31) L		71

THE STANDARD RANGE SERVES VARIOUS MARKETS, INCLUDING:

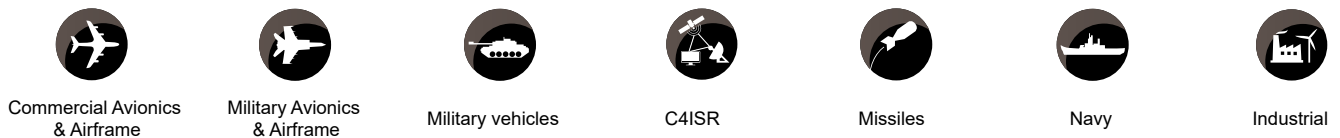

MIL-DTL-38999 SERIES III & EN3645, TV/CTV - GENERAL CHARACTERISTICS

Description

- MIL-DTL-38999 Series III (American - DLA) and EN3645* (European - ASD-STAN) certified.
- Harsh environment applications.
- 9 shell sizes from size 9 to 25.
- More than 80 contacts arrangements.
- Contacts sizes from 23 TO 4/0 : Amphenol designation, AS39029 QPL or EN3155 designations.



For more information about contacts, please refer to dedicated "Contacts" catalog DOC-000081-ANG

Main features

QUICK COUPLING

- Completely mates and self-locks in a 360° turn of the coupling nut.
- Anti-decoupling device allowing high vibration performances.

CONTACT PROTECTION

- 100% scoop proof connector.
- Interfacial seal ensures sealing around each contact and prevents from electrolytic erosion.

EMI/RFI SHIELDING*

- Shell to shell bottoming.
- Grounding fingers on the plug shell.
- Conductive grounding ring.

Receptacles intermountable with MIL-DTL-38999 Series I Standard (same panel cut out)

*Depending on shell plating.



Options

- High density insert (HD38999), Contacts size #23 **HD**.
- Firewall capability **F** (Stainless steel, K & S classes).
- Hermetic - Glass-sealed receptacles (Y & N classes): air leakage limited to $1 \times 10^{-7} \text{ cm}^3$ per second **Y**.
- Enhanced sealing versions for Receptacles (ETC / ETCI).
- Quadrax compatible insert **Q**.
- Ground plane insert **G**.
- Filter using tubular or planar technology: Protection for sensitive circuitry.
- Electrostatic Discharge Protection (ESD).
- Use of the faraday cage principle which shunts high voltage and high current discharge events.

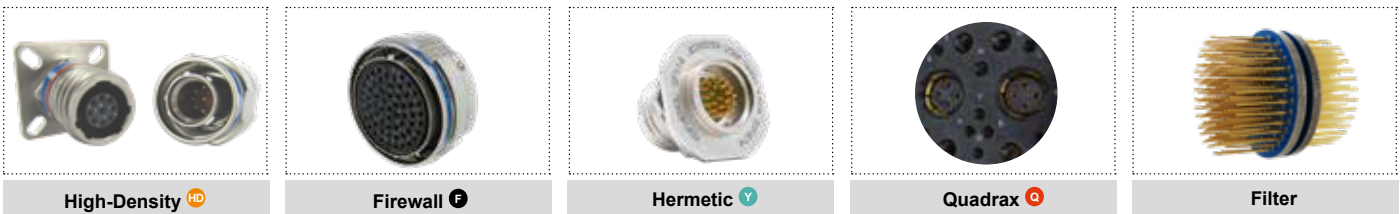

* For more information on EN3645 standard, please consult "EN3645" brochure DOC-001007-ANG

HD High density 38999 - Contacts size 23

F Firewall insert available

Y Available in Hermetic version

Q Compatible with Quadrax contacts (see how to order)

G Ground plane proprietary version available

MIL-DTL-38999 SERIES III & EN3645, TV/CTV - MECHANICAL CHARACTERISTICS

Concept



- ① Coupling nut
- ② Quick coupling thread
- ③ Ratchet
- ④ Anti decoupling device
- ⑤ Plug shell
- ⑥ Grounding spring

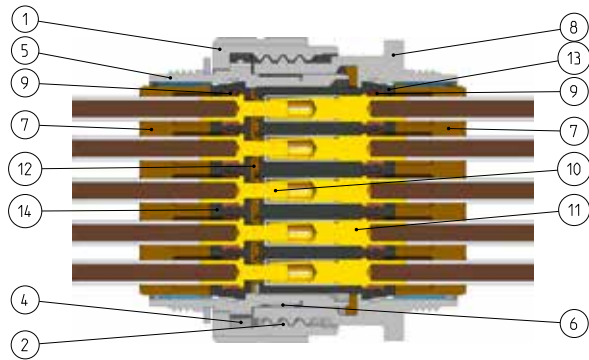

- ⑦ Grommet
- ⑧ Receptacle shell
- ⑨ Contact retention clips
- ⑩ Crimping pin contact
- ⑪ Crimping socket contact
- ⑫ Interfacial seal
- ⑬ Socket insert
- ⑭ Pin insert

Materials and platings

	Material	Plating	Benefit
Shell	Aluminum	Olive drab cadmium, Nickel, Black zinc nickel, Tin Zinc	Robust standard material
	Composite	Olive drab cadmium Nickel	Lightweight: up to 70% weight saving Corrosion resistance: up to 2000 hours salt spray exposure
	Stainless steel	Passivated Nickel	Firewall capability for K & S classes
	Bronze		Corrosion resistance: up to 500 hours salt spray exposure. Robustness for Marine applications
Insert	Thermoplastic or thermoset		
Grommet and interfacial seal	Fluorosilicone		
Contact	Copper alloy	Gold, Tin lead, Silver tin, Silver tin copper	

Mechanical characteristics

Characteristics	MIL-DTL-38999 & EN3645							
Durability	500 mating cycles 1500 mating cycles for composite connector fitted with H and J contacts							
Shock	Half sine wave of 300 G magnitude during 3ms per EIA-364-27							
Vibration	Sine vibrations: - 60g from -55°C to +175°C (Olive drab cadmium and Black zinc nickel) - 60g from -55°C to +200°C (Nickel and Stainless steel) Random vibrations: per EIA-364-28: - 43.92 grms at 175°C (Aluminum with Olive drab cadmium and Black zinc nickel), 50 to 2000 Hz - 43.92 grms at 200°C (Aluminum with Nickel and Stainless steel), 50 to 2000 Hz - 50.09 grms at ambient air Consult us for Durmalon (Nickel PTFE) and Green Zinc cobalt							
Contact retention	Size	23 ^{HD}	22D	20	16	12	8	4
	Max load (N)	44	44	67	111	111	111	150

^{HD} High density 38999. Quadrax and differential Twinax arrangements are not rated over 175°C
 All dimensions are given for information only and are in mm, except as otherwise specified | *in mm: 1mm=0.03937 inch

MIL-DTL-38999 SERIES III & EN3645, TV/CTV - ENVIRONMENTAL CHARACTERISTICS

Corrosion resistance & temperature



	Shell material	Shell finish	Salt spray exposure per EIA 364.26 (hours)	D38999 Service class	Amphenol designation	Operating temperature (°C)		Initial shell to shell conductivity under 1A (mV)
						Min	Max	
Waterproof (IP X7)	Composite	Olive drab cadmium	2000	J	CTV** W**	- 65	+ 175	3
		Nickel	2000	M	CTV** F**	- 65	+ 200 ^{HD}	3
	Aluminum	Olive drab cadmium	500	W	TV** W**	- 65	+ 175	2.5
		Nickel	48	F	TV** F**	- 65	+ 200 ^{HD}	1
		Black zinc nickel	500	Z	TV** ZN**	- 65	+ 175	2.5
		Black Zinc Nickel CrVI free (REACH)	500	Z	TV** ZR**	- 65	+ 175	2.5
		Durmalon (Ni-PTFE)	500	T	TV** DT**	- 65	+ 175	2.5
		Tin Zinc	500	-	TV** TZ**	- 65	+ 175	2.5
	Stainless steel	Nickel	500	S	TV** S**	- 65	+ 200 ^{HD}	1
		Passivated	500	K	TV** K**	- 65	+ 200 ^{HD}	10
Marine bronze	-	500	-	TV** B**	- 65	+ 200 ^{HD}	5	
Hermetic	Stainless steel	Nickel	500	N	TV** YN**	- 65	+ 200 ^{HD}	1
		Passivated	500	Y	TV** Y**	- 65	+ 200 ^{HD}	10

Environmental characteristics

Characteristics	MIL-DTL-38999. M version. Amendment 2
Humidity	§3.30
Altitude immersion	§3.13. except hermetic
Air leakage	§3.10. hermetic only
Fluid immersion	<p>Per EIA 364.10 :</p> <ul style="list-style-type: none"> - Hydraulic fluid, per MIL-H-5606 - Turbine fluid, grade JP-8. per MIL-DTL-83133 (NATO TYPE 34) - Lubricating oil, per MIL-L-7808 - Lubricating oil, per MIL-PRF-23699 - Defrosting fluid, per MIL-A-8243 - Cleaning compound, diluted for cleaning, per MIL-PRF-87937 type I alkaline base - Gasoline, per ASTM-D-4814 - Gasohol, per A-A-52530 - One part isopropyl alcohol, per TT-I-735, grade A or B ; and 3 parts mineral spirits, per A-A-2904, type II, grade A or P-D-680, type I, by volume - Coolant, dielectric fluid, synthetic silicate ester base MIL-PRF-47220 (Coolanol 25) or equivalent

Consult us for EN3645 test details (fluids & lightning strike)

^{HD} High density 38999, Quadrax and differential Twinax arrangements not rated over 175°C

All dimensions are given for information only and are in mm, except as otherwise specified | *in mm: 1mm=0.03937 inch

Series III TV-CTV
Series II JT
Series I LJT
Accessories & tools
Assembly instructions

MIL-DTL-38999 SERIES III & EN3645, TV/CTV - ELECTRICAL CHARACTERISTICS

Service rating

Service rating	Dielectric withstanding voltage (Vrms)								Working voltage	
	At sea level		15 000 meters		21 000 meters		34 000 meters		Vrms	Vdc
	Mated	Unmated	Mated	Unmated	Mated	Unmated	Mated	Unmated		
N ^{HD}	1000	1000	600	400	600	260	600	200	300	450
M	1300	1300	800	550	800	350	800	200	400	550
I	1800	1800	1000	600	1000	400	1000	200	600	850
II	2300	2300	1000	800	1000	500	1000	200	900	1250

Contacts and cables

For more information about contacts, please refer to dedicated Contacts catalog DOC-000081-ANG

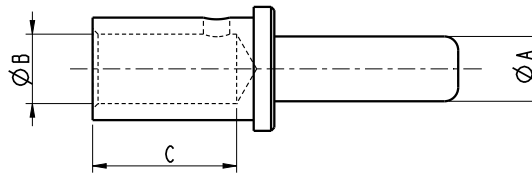

Contact characteristics		Contact size								
	Contact termination	23 ^{HD}	22D	20	16	12	8 ^{**}	4 ^{**}	00 ^{**}	
Contact rating (nominal current per contact, A) at ambient temperature	Crimp barrel	5	5	7.5	13	23	60	100	250 [*]	
	PC tail	3	3	4.5	10	17	40			
	Hermetic	3	3	5	10	17				
Contact resistance (without wire, mΩ)		15	8	4.7	2	1.1	0.6	0.26	0.102	
Insulation resistance (MΩ)		> 5.10 ³ at ambient temperature > 1.10 ³ at maximum temperature								
ØA Pin contact diameter (mm) (mating area)		0.68	0.76	1	1.57	2.36	3.60	5.70	12.0	
Crimp barrel	ØB Diameter (mm)	0.88 ± 0.03	0.88 ± 0.03	1.19 ± 0.03	1.70 ± 0.03	2.54 ± 0.06	4.6 ± 0.05	7.4 ± 0.05	12.1	
	C Depth (mm)	3.81	3.58	5.30	5.30	10	10	12	21	
Acceptable cables	American wire gauge AWG									
	28	0.095								
	26	0.15								
	24	0.22								
	22	0.38								
	20	0.60								
	18	0.93								
	16	1.34								
	14	1.94								
	12	3.30								
	8 ^{**}	8.98-10 _{MAX}								
	4 ^{**}	21.10 [▲]								
	00 ^{**}	75								
0000 ^{**}										
Outside diameter (mm)	MIN	0.76	0.76	1.02	1.68	2.46	4.50	7.73		
	Average		1.20	1.83	2.41	3.20				
	MAX	1.27	1.37	2.11	2.77	3.61	5.20	8.40		

^{*} 185A according to AS39029 standard. 230A only for 23-P1 arrangement with Radsok technology
^{**} Consult us for other cable dimensions
[▲] Concentric wire only (contacts 900007 & 900047). For others cables types consult us.
^{HD} High density 38999, Quadrax and differential Twinax arrangements not rated over 175°C

All dimensions are given for information only and are in mm, except as otherwise specified | *in mm: 1mm=0.03937 inch

MIL-DTL-38999 SERIES III & EN3645, TV/CTV - TV - METAL SHELLS

Metal connectors dedicated to harsh environments.

Amphenol TV Tri-start MIL-DTL-38999 Series III Connectors offer the highest performance capabilities. These connectors are MIL-DTL-38999 Series III & EN3645 qualified. Available in different materials & platings, TV Connectors are dedicated to severe environments applications where a high reliability is critical.



Main features

STANDARDIZED MILITARY CONNECTORS (DLA - MIL-DTL-38999 & ASD-STAN EN3645)

MATERIALS & PLATINGS

- Aluminum, Stainless steel or Marine bronze.
- Platings: Olive drab cadmium, Nickel, Black zinc nickel, Tin Zinc or Durmalon (Nickel PTFE).



SHELL STYLES OPTIONS

- Receptacle:
 - Square flange (Wall mount) or Jam nut.
 - Box mount or in-line versions upon request.
 - Straight plug
- G Ground plane proprietary option available (metal insert for use with Coaxial, Twinax or Quadrax contacts).
F Firewall versions available for Stainless steel shells

Technical characteristics

	ALUMINUM					STAINLESS STEEL		MARINE BRONZE
	Many platings & options available					High temperature harsh vibrations & firewall		Conform to CECC 75.201.002
Plating	Olive Drab Cadmium	Black zinc nickel	Nickel	Tin Zinc	Durmalon	Passivated	Nickel	-
Amphenol	W	ZN / ZR	F	TZ	DT	K	S	B
Military	W	Z	F	-	T	K	S	-
RoHS compliant	No	Yes ✓			Yes ✓		Yes ✓	
Salt spray (hours)	500		48		500	500		500
Temperature max (°C)	175		200 ^{HD}		175	200 ^{HD}		200 ^{HD}
Shell to shell conductivity (mΩ) ^G	2.5	2.5	1	2.5	2.5	10	1	5
EMI shielding (@ 1GHz)	-85dB	-85dB	-85dB		-85dB	-65dB	-85dB	-65dB
EMI shielding (@ 10GHz)	-65dB	-50dB	-65dB		-50dB	-45dB	-65dB	-65dB
Firewall ^F	No					Yes		No

✓ : RoHS compliant

^G 10mΩ for grounded version

^{HD} High density 38999, Quadrax and differential Twinax arrangements not rated over 175°C

All dimensions are given for information only and are in mm, except as otherwise specified | *in mm: 1mm=0.03937 inch

Series III TV-CTV
Series II JT
Series I LJT
Accessories & tools
Assembly instructions

MIL-DTL-38999 SERIES III & EN3645, TV/CTV - HOW TO ORDER CRIMP VERSIONS

Military Designations - DLA MIL-DTL-38999 SERIES III Connectors

Military designation connectors ordered with contacts are delivered with the full quantity of required contacts plus spare contacts for each size used in the insert arrangements (1 for the contacts arrangements with 26 contacts or less, 2 spares the others - except for Coax & Twinax), sealing plugs (10% of the number of contacts) and one installation/removal tool per contact size.

Series	1. Shell type	2. Material and platings	3. Shell size	4. Contact arrangement	5. Contact gender	6. Keying
D38999/	26	W	B	35	P	N

1. Shell type

Shell type	Receptacle	Plug
20	Square flange receptacle (Wall mount)	
24	Jam nut receptacle	
26		Straight plug

2. Material and platings

Material	Shell material	Shell finish
W	Aluminum	Olive Drab Cadmium
F		Electroless Nickel ✓
Z		Black Zinc Nickel ✓
K	Stainless steel	Passivated ✓
S		Electrodeposited Nickel ✓
J	Composite	Olive Drab Cadmium
M		Nickel ✓

3. Shell size

A	B	C	D	E	F	G	H	J
09	11	13	15	17	19	21	23	25

4. Contact arrangement

Refer to page 18 for contact arrangements

5. Contact gender

P	Pin contacts (500 cycles)
S	Socket contacts (500 cycles)
A	Less pin contacts
B	Less socket contacts
H	Pin contacts, composite only (1500 cycles)
J	Socket contacts, composite only (1500 cycles)

6. Keying

N	A	B	C	D	E
(for normal)					

Refer to page 28 for keying information

ASD STAN Designations - EN3645 Connectors

EN3645 designation connectors ordered with contacts are delivered with the full quantity of required contacts plus spare contacts for each size used in the insert arrangements (1 for the contacts arrangements with 26 contacts or less, 2 spares the others - except for High-Speed & size #8 power), sealing plugs (15% of the number of contacts) and one installation/removal tool per contact size.

Series	1. Material and platings	2. Shell type	3. Shell size	4. Insert type	5. Contact arrangement	6. Contact gender	7. Keying
EN3645	F	0	B	N	35	M	N

1. Material and platings

Material	Shell material	Shell finish
W	Aluminum	Olive Drab Cadmium
F		Electroless Nickel ✓
J	Composite	Olive drab cadmium
M		Nickel ✓

2. Shell type

0	Square flange receptacle (Wall mount)
7	Jam nut receptacle
6	Straight plug

3. Shell size

A	B	C	D	E	F	G	H	J
09	11	13	15	17	19	21	23	25

4. Insert type

N	Standard insert
G	Conductive insert (Grounded cavities) Ⓞ
L	Insert with Quadrax cavities (Not grounded) Ⓞ
Q	Conductive Insert with Quadrax cavities (Grounded) ⓄⓄ
R	Power insert (for 21-48 arrangement only)

Inserts type G, Q, L and R are for informations only, Amphenol is not qualified yet. 09-05 contact arrangement with insert type G and Q, along with inserts type L are available under our proprietary designation, please consult us.

5. Contact arrangement

Refer to page 18 for contact arrangements - EN3645 only.

6. Contact gender

M	Pin (500 cycles)
F	Socket (500 cycles)
A	Without pin contacts
B	Without socket contacts

Connectors intended for equipping with coaxial, triaxial, quadrax, size #8 power, thermocouple or special contacts shall be ordered without contacts.

7. Keying

N	A	B	C	D	E
(for normal)					

All dimensions are given for information only and are in mm, except as otherwise specified | *in mm: 1mm=0.03937 inch

MIL-DTL-38999 SERIES III & EN3645, TV/CTV - HOW TO ORDER CRIMP VERSIONS

Amphenol Designations - TV & CTV Crimp Connectors

1.	2.	3.	4.	5.	6.	7.	8.	9.	10.
Series	Shell type	Crimp contacts	Ground plane and Quadrax	Material and platings	Contact arrangement	Contact gender	Keying	With or without contacts	Deviation
TV	P00	R	Q	W	17-02	P	A	-	

1. Series

TV	Metal shells (Aluminum, Stainless Steel, Marine Bronze)
CTV	Composite shells

2. Shell type

	Shell type	Associated materials and platings	Temperature
P00	Square flange - Wall mount receptacle	W, ZN, ZR, TZ	+175°C
PS00 *		F, K, S, B	+200° C *
P02	Square flange - Box mount receptacle (no rear thread)	W, ZN,ZR, ZR, TZ	+175°C
PS02 *	(non-standard shells, please consult us)	F, K, S, B	+200° C *
07	Jam nut receptacle	W, ZN, ZR, TZ	+175°C
S07 *		F, K, S, B	+200° C *
01	In-line receptacle	W, ZN, ZR, TZ	+175°C
S01 *	(non-standard shells, please consult us)	F, K, S, B	+200° C *
06	Straight plug	W, ZN, ZR, TZ	+175°C
S06 *		F, K, S, B	+200° C *

* «S» Stand for 200°C compatibility. Omit for High-density inserts ☺, inserts with Quadrax contacts and differential Twinax contacts ☹ are +175°C maxi compatible.

3. Crimp contacts

R	For W, F, Z, K, S and B materials & platings (ex: TV06RW1535P)
Blank	For ZN and TZ platings (ex: TV06ZN1535P)

4. Conductive inserts & inserts for Quadrax and differential Twinax contacts (optional)

Conductive inserts are available for Aluminum versions with Olive Drab Cadmium, Tin Zinc and Electroless Nickel. For any others materials and platings please consult us.

Blank	For standard inserts without ground plane and indexation key.
G	☺ Ground Plane version - Conductive insert. Mandatory for 09-05*.
Q	☹ Inserts designed with an indexation key to avoid contacts rotation in the cavities when using a keyed contact - Size 8 contacts only.
GQ	☺☹ Ground plane version with insert designed with an indexation key.

* Please note that 09-05 insert is automatically conductive. Add the 'G' letter in all your references for this arrangement.

5. Material and platings

W		Olive Drab Cadmium
F		Electroless Nickel ✓
ZN	Aluminum	Black Zinc Nickel ✓
ZR		Black Zinc Nickel CrVI free ✓
TZ		Tin Zinc ✓
K	Stainless steel	Passivated ✓
S		Electrodeposited Nickel ✓
B	Marine Bronze* ✓	-
W	Composite	Olive Drab Cadmium
F		Nickel ✓

* Copper aluminum alloy
For other platings, please consult us (ex: Duralon Nickel PTFE)

6. Contact arrangement

Refer to page 18 for contact arrangements. First number represents the shell size and second number is the contact arrangement.

7. Contact gender

P	Pin (500 cycles)
S	Socket (500 cycles)
H	Pin (1500 cycles. CTV only)
J	Socket (1500 cycles. CTV only)

8. Keying

Blank (for normal)	A	B	C	D	E	U (Universal) Consult us
--------------------	---	---	---	---	---	--------------------------

Refer to page 28 for more information.

9. With or without contacts

Blank	Connector delivered with contacts
LC	Connector delivered without contacts

10. Deviation

Deviation	Description	Shell type compatibility
F485	Marine Bronze plugs only – Coupling nut conforms to CECC75-201-002A (Artic gloves)	TV*06RB

For other deviations, please consult us or next section - MIL-DTL-38999 Extended Range

Series III TV-CTV
Series II JT
Series I LJT
Accessories & tools
Assembly instructions

MIL-DTL-38999 SERIES III & EN3645, TV/CTV - HOW TO ORDER PC-TAIL VERSIONS

Amphenol Designations - TV & CTV PCB Receptacles



1.	2.	3.	4.	5.	6.	7.	8.	9.
Series	Shell type	Ground plane and Quadrax	Material and plating	PC Tail contacts	Contact arrangement	Contact gender	Keying	Deviation
TV	S07	-	F	CI	15-35	P	A	

1. Series

TV	Metal shells
CTV	Composite shells



2. Shell type

	Shell type	Associated materials and platings	Temperature
P00	Square flange - Wall mount receptacle	W, ZN, ZR, TZ	+175°C
PS00 *	Square flange - Wall mount receptacle	F, K, S, B	+200° C *
P02	Square flange - Box mount receptacle (no rear thread)	W, ZN, ZR, TZ	+175°C
PS02 *	Square flange - Box mount receptacle (no rear thread) (non-standard shells, please consult us)	F, K, S, B	+200° C *
07	Jam nut receptacle	W, ZN, ZR, TZ	+175°C
S07 *	Jam nut receptacle	F, K, S, B	+200° C *

* «S» Stand for 200°C compatibility. Omit for High-density inserts , inserts with Quadrax contacts and differential Twinax contacts  are +175°C maxi compatible.

3. Conductive inserts & inserts for Quadrax and differential Twinax contacts (optional)

Conductive inserts are available for Aluminum versions with Olive Drab Cadmium, Tin Zinc and Electroless Nickel. For any others materials and platings please consult us.

Blank	For standard inserts without ground plane and indexation key.
G	 Ground Plane version - Conductive insert. Mandatory for 09-05*.
Q	 Inserts designed with an indexation key to avoid contacts rotation in the cavities when using a keyed contact - Size 8 contacts only.
GQ	 Ground plane version with insert designed with an indexation key.

* Please note that 09-05 insert is automatically conductive. Add the 'G' letter in all your references for this arrangement.

4. Material and platings

W		Olive Drab Cadmium
F		Electroless Nickel ✓
ZN	Aluminum	Black Zinc Nickel ✓
ZR		Black Zinc Nickel CrVI free ✓
TZ		Tin Zinc ✓
K		Passivated ✓
S	Stainless steel	Electrodeposited Nickel ✓
B	Marine Bronze* ✓	-
W		Olive Drab Cadmium
F	Composite	Nickel ✓

* Copper aluminum alloy
For other platings, please consult us (ex: Duralon Nickel PTFE)

5. PC Tail contacts

CI	Standard length (5 mm)
LI	Long length (8.5 mm)
SI	Short length (size 22D contacts only) (4 mm)

For shorter contacts on box mount receptacles (P02 and PS02), please consult us.

6. Contact arrangement

Refer to page 18 for contact arrangements
First number represents the shell size and second number is the contact arrangement

7. Contact gender

P	Pin (500 cycles)
S	Socket (500 cycles)

Connectors with PC Tail contacts are always delivered with contacts.

8. Keying

Blank (for normal)	A	B	C	D	E	U (Universal) Consult us
--------------------	---	---	---	---	---	--------------------------

Refer to page 28 for more information.

9. Deviation

	Tin lead	Silver tin ✓	Silver tin copper ✓	Gold ✓
PC Tail finish / Tinning	F404	F404LF	F404LFC	Blank

All dimensions are given for information only and are in mm, except as otherwise specified | *in mm: 1mm=0.03937 inch

MIL-DTL-38999 SERIES III & EN3645, TV/CTV - TV - METAL RECEPTACLES

Overall dimensions Square flange - Wall mount receptacle

AMPHENOL	MILITARY	ASD-STAN
TVP00RW*	D38999/20W*	EN3645W0*
TVPS00RF*	D38999/20F*	EN3645F0*
TVP00ZN*	D38999/20Z*	-
TVP00ZR*	-	-
TVP00TZ*	-	-
TVPS00RB*	-	-
TVP00DT*	D38999/20T*	-
TVPS00RK*	D38999/20K*	EN3645K0*
TVPS00RS*	D38999/20S*	-

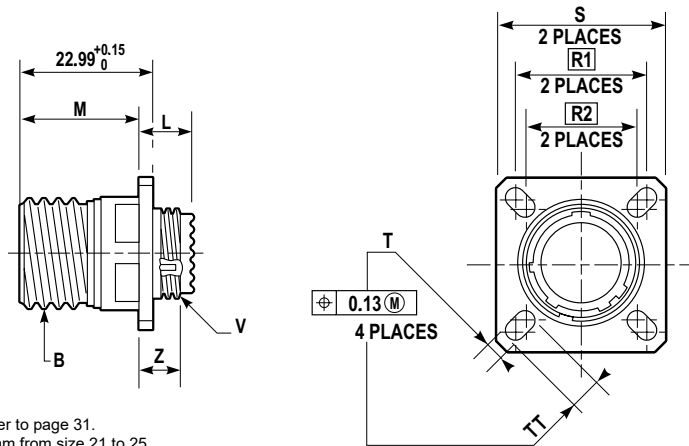

For panel hole dimensions, please refer to page 29. For PCB contacts, please refer to page 31.
Maximum panel thickness for back panel mounting: 5.8 mm from size 9 to 19; 5 mm from size 21 to 25.

Size		B thread class 2A .1P-.3L-TS (inch)	V thread-metric	M ^{+0 -0.13}	L _{MAX}	Z _{MAX}	S ^{±0.3}	R1	R2	T ^{±0.2}	TT ^{±0.2}
Amphenol	Military										
9	A	.6250	M12x1-6g	20.83	11.91	3.89	23.8	18.26	15.09	3.25	5.49
11	B	.7500	M15x1-6g	20.83	11.91	3.89	26.2	20.62	18.26	3.25	4.93
13	C	.8750	M18x1-6g	20.83	11.91	3.89	28.6	23.01	20.62	3.25	4.93
15	D	1.0000	M22x1-6g	20.83	11.91	3.89	31.0	24.61	23.01	3.25	4.39
17	E	1.1875	M25x1-6g	20.83	11.91	3.89	33.3	26.97	24.61	3.25	4.93
19	F	1.2500	M28x1-6g	20.83	11.91	3.89	36.5	29.36	26.97	3.25	4.93
21	G	1.3750	M31x1-6g	20.07	12.70	4.65	39.7	31.75	29.36	3.25	4.93
23	H	1.5000	M34x1-6g	20.07	12.70	4.65	42.9	34.93	31.75	3.91	6.15
25	J	1.6250	M37x1-6g	20.07	12.70	4.65	46.0	38.10	34.93	3.91	6.15

Square flange - Box mount receptacle

AMPHENOL

- TVP02RW*
- TVPS02RF*
- TVP02ZN*
- TVPS02ZR*
- TVP02TZ*
- TVPS02RK*
- TVPS02RS*

Consult us for availability

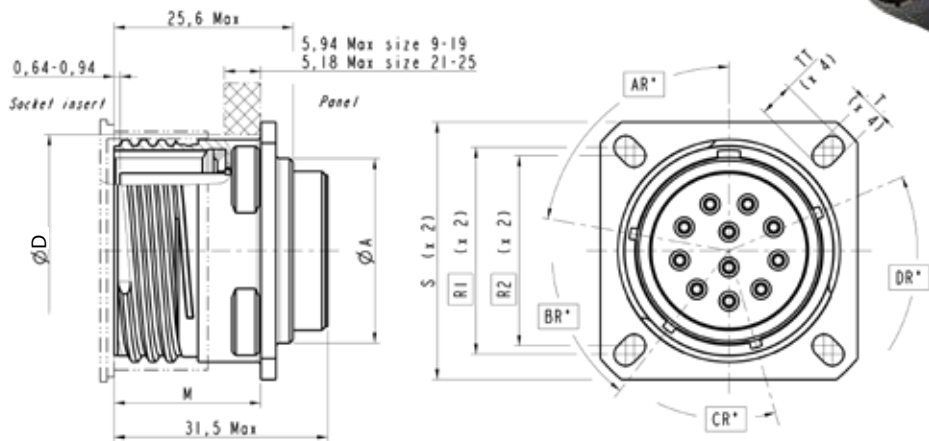

For panel hole dimensions, please refer to page 29.

Size	ØD _{MIN}	M ^{+0 -0.13}	ØA ^{±0.13}	S ^{±0.3}	R1	R2	T ^{±0.2}	TT ^{±0.2}
9	16.66	20.83	11	23.83	18.26	15.09	3.25	5.49
11	20.22	20.83	14.15	26.19	20.62	18.26	3.25	4.93
13	23.42	20.83	17.17	28.58	23.01	20.62	3.25	4.93
15	26.59	20.83	20.35	30.96	24.61	23.01	3.25	4.39
17	30.96	20.83	23.52	33.32	26.97	24.61	3.25	4.93
19	32.94	20.83	26.21	36.53	29.36	26.97	3.25	4.93
21	36.12	20.07	29.39	39.67	31.75	29.36	3.25	4.93
23	39.29	20.07	32.56	42.88	34.93	31.75	3.91	6.15
25	42.47	20.07	35.74	46.02	38.10	34.93	3.91	6.15

All dimensions are given for information only and are in mm, except as otherwise specified | *in mm: 1mm=0.03937 inch

Due to technical modifications, all information provided is subject to change without prior notice
Designed by Amphenol Socapex

Series III TV-CTV
Series II JT
Series I LJT
Accessories & tools
Assembly instructions

MIL-DTL-38999 SERIES III & EN3645, TV/CTV - TV - METAL RECEPTACLES

Jam nut receptacle



AMPHENOL	MILITARY	ASD-STAN
TV07RW*	D38999/24W*	EN3645W7*
TVS07RF*	D38999/24F*	EN3645F7*
TV07ZN*	D38999/24Z*	-
TV07TZ*	-	-
TVS07RB*	-	-
TV07DT*	D38999/24T*	-
TVS07RK*	D38999/24K*	EN3645K7*
TVS07RS*	D38999/24S*	-

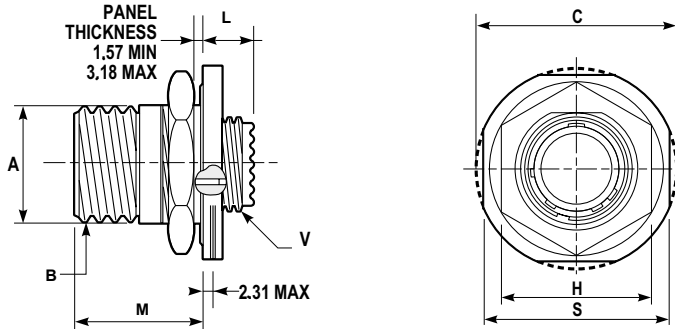

For panel hole dimensions, please refer to page 29. For PCB contacts. Please refer to page 31.

Size		B thread class 2A .1P-.3L-TS (inch)	V thread-metric	M	L _{MAX}	ØA ^{+0.10 -0.15}	ØC _{MAX}	S ± 0.4	H ± 0.4	Hex nut torque N.m _{MINMAX}
Amphenol	Military									
9	A	.6250	M12x1-6g	22.12	9.11	16.53	30.5	27.0	22.2	3.4/4.1
11	B	.7500	M15x1-6g	22.12	9.11	19.07	35.2	31.8	25.4	4.5/5.2
13	C	.8750	M18x1-6g	22.30	9.04	23.82	38.4	34.9	30.2	6.2/6.8
15	D	1.0000	M22x1-6g	22.30	9.04	26.97	41.6	38.1	33.3	7.9/8.5
17	E	1.1875	M25x1-6g	22.30	9.04	30.15	44.8	41.3	36.5	9/9.6
19	F	1.2500	M28x1-6g	22.30	9.04	33.32	49.5	46.0	39.7	10.2/10.7
21	G	1.3750	M31x1-6g	22.30	9.04	36.50	52.7	49.2	42.9	11.3/12.4
23	H	1.5000	M34x1-6g	22.30	9.04	39.67	55.9	52.4	46.0	12.4/13.6
25	J	1.6250	M37x1-6g	22.30	9.04	42.85	59.0	55.6	50.8	13.6/14.7

In-line receptacle



AMPHENOL

- TV01RW*
- TVS01RF*
- TV01ZN*
- TV01ZR*
- TV07ZR*
- TV01TZ*
- TVS01RK*
- TVS01RS*

Consult us for availability

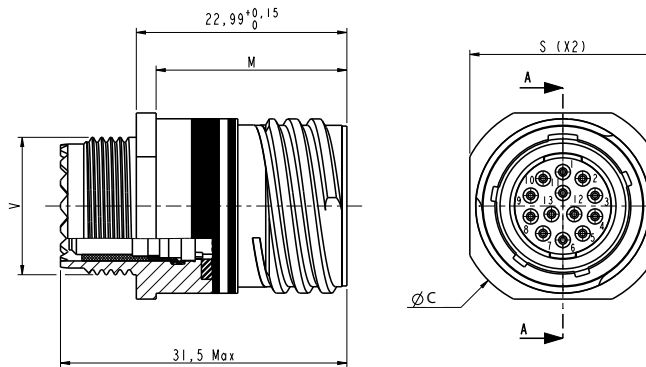

Size	V thread-metric	M ^{+0 -1.25}	ØC ± 0.25	S ± 0.25
9	M12x1-6g	20.83	20.62	17.15
11	M15x1-6g	20.83	22.99	20.32
13	M18x1-6g	20.83	27.76	23.50
15	M22x1-6g	20.83	30.96	26.67
17	M25x1-6g	20.83	34.93	31.45
19	M28x1-6g	20.83	37.31	33.02
21	M31x1-6g	20.07	41.28	36.20
23	M34x1-6g	20.07	44.45	39.37
25	M37x1-6g	20.07	47.63	42.55

All dimensions are given for information only and are in mm, except as otherwise specified | *in mm: 1mm=0.03937 inch

Due to technical modifications, all information provided is subject to change without prior notice
Designed by Amphenol Socapex

MIL-DTL-38999 SERIES III & EN3645, TV/CTV - TV - METAL PLUGS

Straight plug



AMPHENOL	MILITARY	ASD-STAN
TV06RW*	D38999/26W*	EN3645W6*
TVS06RF*	D38999/26F*	EN3645F6*
TV06ZN*	D38999/26Z*	-
TV06ZR*	-	-
TV06TZ*	-	-
TVS06RB*	-	-
TV06DT*	D38999/26T*	-
TVS06RK*	D38999/26K*	EN3645K6*
TVS06RS*	D38999/26S*	-

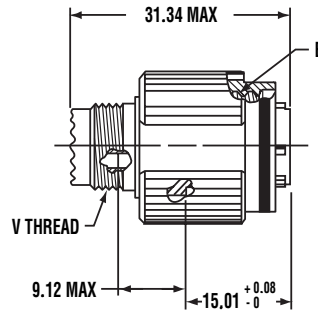
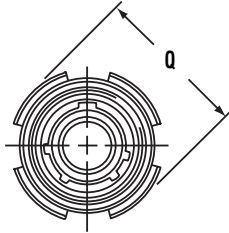

Size		ØQ _{MAX}	B thread class 2B .1P-.3L-TS (inch)	V thread metric
Amphenol	Military			
9	A	21.8	.6250	M12x1-6g
11	B	25.0	.7500	M15x1-6g
13	C	29.4	.8750	M18x1-6g
15	D	32.5	1.0000	M22x1-6g
17	E	35.7	1.1875	M25x1-6g
19	F	38.5	1.2500	M28x1-6g
21	G	41.7	1.3750	M31x1-6g
23	H	44.9	1.5000	M34x1-6g
25	J	48.0	1.6250	M37x1-6g

Coupling nut for arctic gloves - Marine Bronze plugs only



AMPHENOL
TVS06RB**F485
TVS06RB**F485A

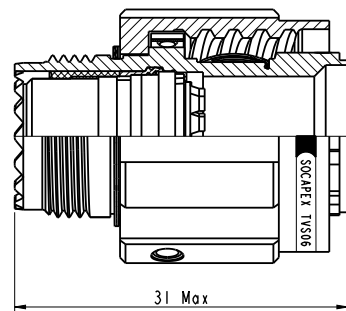
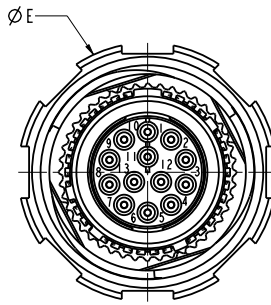
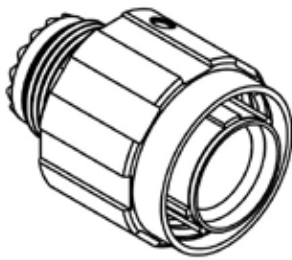

Note : F485A is compliant with CECC 75201-002

Size	ØE _{MAX}
9	21.1
11	23.8
13	28.2
15	31.4
17	36.5
19	39.3
21	42.5
23	45.3
25	48.4

All others dimensions & threads remains the same than 38999 series III / TV plugs.

All dimensions are given for information only and are in mm, except as otherwise specified | *in mm: 1mm=0.03937 inch

Due to technical modifications, all information provided is subject to change without prior notice
Designed by Amphenol Socapex

Series III TV-CTV
Series II JT
Series I LJT
Accessories & tools
Assembly instructions

MIL-DTL-38999 SERIES III & EN3645, TV/CTV - CTV - COMPOSITE SHELLS

Composite for weight saving & high corrosion resistance

Description

Qualified to MIL-DTL-38999 Series III & EN3645 standards, the Amphenol Composite Tri-Start connectors offers a lightweight corrosion resistant connector with the same high performances features as the metal versions.



Main features

- Composite lightweight material:
 - 20 to 40% weight saving vs Aluminum.
 - 60 to 70% weight saving vs Stainless steel.
- Platings: Olive drab cadmium or Nickel.

SHELL STYLES OPTIONS

- Receptacle: Square Flange - Wall mount or Jam nut.
- Straight plug

G Ground plane proprietary option available (metal insert for use with high speed contacts, Coaxial, Twinax or Quadrax)

Technical characteristics

Plating	Composite	
	Olive drab cadmium W	Nickel F
RoHS compliant	No	Yes ✓
Salt spray (hours)	2000	
Temperature (°C)	175	200 HD
Shell to shell continuity (mΩ) G	3	
EMI shielding (@ 10GHz)	-50dB	-65dB
Firewall F	No	

G 10mΩ for grounded version

HD High density 38999, Quadrax, differential Twinax arrangements not rated over 175°C

Overall dimensions

Square flange - Wall mount receptacle

AMPHENOL	MILITARY	ASD-STAN
CTVP00RW*	D38999/20J*	EN3645J0*
CTVPS00RF*	D38999/20M*	EN3645M0*

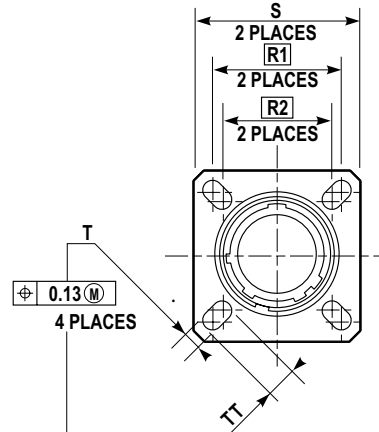
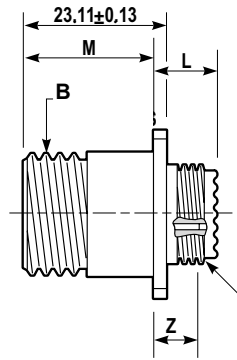

For panel hole dimensions, please refer page 29.
For PCB contacts please refer to page 31.
Maximum panel thickness for back panel mounting: 5.8 mm from size 9 to 19; 5 mm from size 21 to 25.

Size		B thread class 2A .1P-.3L-TS (inch)	V thread-metric	M ^{+0 -0.13}	L _{Max}	Z _{MAX}	S ^{±0.3}	R1	R2	T ^{±0.2}	TT ^{±0.2}	V thread-metric
9	A	.6250	M12x1-6g	19.63	13.06	5.03	23.8	18.26	15.09	3.25	5.49	M12x1-6g
11	B	.7500	M15x1-6g	19.63	13.06	5.03	26.2	20.62	18.26	3.25	4.93	M15x1-6g
13	C	.8750	M18x1-6g	19.63	13.06	5.03	28.6	23.01	20.62	3.25	4.93	M18x1-6g
15	D	1.0000	M22x1-6g	19.63	13.06	5.03	31.0	24.61	23.01	3.25	4.39	M22x1-6g
17	E	1.1875	M25x1-6g	19.63	13.06	5.03	33.3	26.97	24.61	3.25	4.93	M25x1-6g
19	F	1.2500	M28x1-6g	19.63	13.06	5.03	36.5	29.36	26.97	3.25	4.93	M28x1-6g
21	G	1.3750	M31x1-6g	18.82	13.84	5.79	39.7	31.75	29.36	3.25	4.93	M31x1-6g
23	H	1.5000	M34x1-6g	18.82	13.84	5.79	42.9	34.93	31.75	3.91	6.15	M34x1-6g
25	J	1.6250	M37x1-6g	18.82	13.84	5.79	46.0	38.10	34.93	3.91	6.15	M37x1-6g

All dimensions are given for information only and are in mm, except as otherwise specified | *in mm: 1mm=0.03937 inch

Due to technical modifications, all information provided is subject to change without prior notice
Designed by Amphenol Socapex

MIL-DTL-38999 SERIES III & EN3645, TV/CTV - CTV - COMPOSITE SHELLS

Jam nut receptacle



AMPHENOL	MILITARY	ASD-STAN
CTV07RW*	D38999/24J*	EN3645J7*
CTVS07RF*	D38999/24M*	EN3645M7*

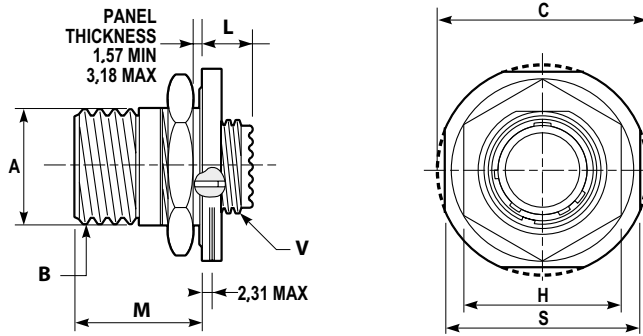

For panel hole dimensions, please refer page 29.
For PCB contacts please refer to page 31.

Size		B thread class 2A .1P-.3L-TS (inch)	V thread-metric	M	L _{MAX}	ØA ^{+0.10 -0.15}	ØC _{MAX}	S ±0.4	H ±0.4	Hex nut MIN/MAX torque N.m
Amphenol	Military									
9	A	.6250	M12x1-6g	22.12	9.11	16.53	30.5	27.0	22.2	3.4/4.1
11	B	.7500	M15x1-6g	22.12	9.11	19.07	35.2	31.8	25.4	4.5/5.2
13	C	.8750	M18x1-6g	22.30	9.04	23.82	38.4	34.9	30.2	6.2/6.8
15	D	1.0000	M22x1-6g	22.30	9.04	26.97	41.6	38.1	33.3	7.9/8.5
17	E	1.1875	M25x1-6g	22.30	9.04	30.15	44.8	41.3	36.5	9/9.6
19	F	1.2500	M28x1-6g	22.30	9.04	33.32	49.5	46.0	39.7	10.2/10.7
21	G	1.3750	M31x1-6g	22.30	9.04	36.50	52.7	49.0	42.9	11.3/12.4
23	H	1.5000	M34x1-6g	22.30	9.04	39.67	55.9	52.4	46.0	12.4/13.6
25	J	1.6250	M37x1-6g	22.30	9.04	42.85	59.0	55.6	50.8	13.6/14.7

Straight plug



AMPHENOL	MILITARY	ASD-STAN
CTV06RW*	D38999/26J*	EN3645J6*
CTVS06RF*	D38999/26M*	EN3645M6*

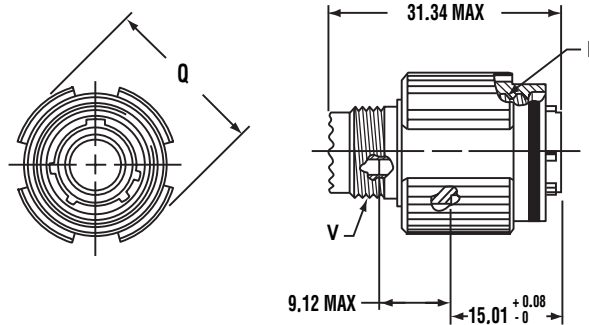

Size		B thread class 2B .1P-.3L-TS (inch)	ØQ _{MAX}	V thread-metric
Amphenol	Military			
9	A	.6250	21.8	M12x1-6g
11	B	.7500	25.0	M15x1-6g
13	C	.8750	29.4	M18x1-6g
15	D	1.0000	32.5	M22x1-6g
17	E	1.1875	35.7	M25x1-6g
19	F	1.2500	38.5	M28x1-6g
21	G	1.3750	41.7	M31x1-6g
23	H	1.5000	44.9	M34x1-6g
25	J	1.6250	48.0	M37x1-6g

All dimensions are given for information only and are in mm, except as otherwise specified | *in mm: 1mm=0.03937 inch

Due to technical modifications, all information provided is subject to change without prior notice
Designed by Amphenol Socapex

Series III TV-CTV
Series II JT
Series I LJT
Accessories & tools
Assembly instructions

MIL-DTL-38999 SERIES III & EN3645, TV/CTV - PC-TAILS RECEPTACLE

PCB drilling - PC-Tail Contacts hole diameters

Contact size	Minimum hole diameter (PCB Drilling)					
	CI (5mm contact length)		LI (8.5 mm contact length)		SI (4 mm contact length)	
	Gold plated contacts	Tin, tin lead, silver tin or silver tin copper plated contacts	Gold plated contacts	Tin, tin lead, silver tin or silver tin copper plated contacts	Gold plated contacts	Tin, tin lead, silver tin or silver tin copper plated contacts
23 ^{HD}	0.8	0.9	0.8	0.9	Not applicable, size 22 only	
22	0.8	0.9	1.0	1.1	1	1.1
20	1.0	1.1	1.0	1.1	Not applicable, size 22 only	
16	1.45	1.55	1.45	1.55	Not applicable, size 22 only	
12	2.0	2.1	2.0	2.1	Not applicable, size 22 only	

PC-Tail lengths - TV & CTV Receptacles (MIL-DTL-38999 Series III)

Note: the most common contact stickouts are listed in this catalog. For the others tail lengths availability, please consult Amphenol Socapex. Back panel mounting illustrated.

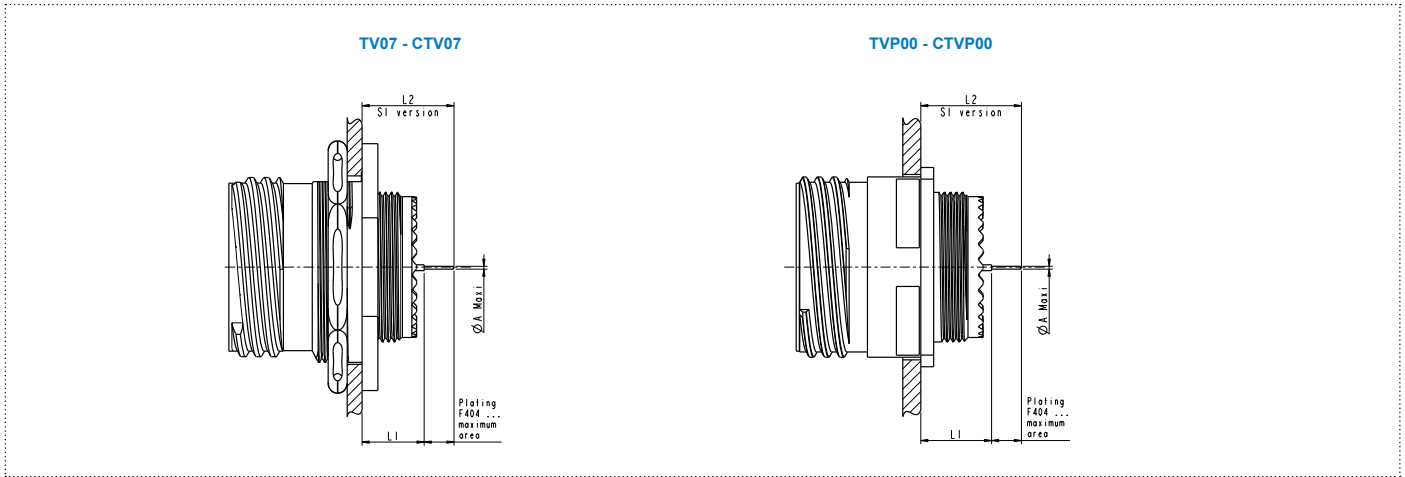

For HD38999 inserts (size 23 contacts), contact lengths are listed for pins only. Consult us for socket versions.

		CI (5 mm contact length)				LI (8.5 mm contact length)				SI (4 mm contact length)										
		TV 07 - CTV 07		TVP 00		CTVP 00		TV 07 - CTV 07		TVP 00		CTVP 00								
		9 & 11	13 to 25	9 to 19	21 to 25	9 to 19	21 to 25	9 & 11	13 to 25	9 to 19	21 to 25	9 to 19	21 to 25							
Pin	L1	MIN	10.13	9.95	11.55	12.31	12.71	13.47	10.13	9.95	11.55	12.31	12.71	13.47	10.13	9.95	11.55	12.31	12.71	13.47
		MAX	11.07	10.89	12.39	13.15	13.52	14.28	11.07	10.89	12.39	13.15	13.52	14.28	11.07	10.89	12.39	13.15	13.52	14.28
	L2	MIN	15.03	14.85	16.45	17.21	17.61	18.37	18.53	18.35	19.95	20.71	21.11	21.87	14.03	13.85	15.45	16.21	16.61	17.37
		MAX	16.17	15.99	17.49	18.25	18.62	19.38	19.67	19.49	20.99	21.75	22.12	22.88	15.17	14.99	16.49	17.25	17.62	18.38
Socket	L1	MIN	9.93	9.75	11.35	12.11	12.51	13.27	9.93	9.75	11.35	12.11	12.51	13.27	9.93	9.75	11.35	12.11	12.51	13.27
		MAX	10.87	10.69	12.19	12.95	13.32	14.08	10.87	10.69	12.19	12.95	13.32	14.08	10.87	10.69	12.19	12.95	13.32	14.08
	L2	MIN	14.83	14.65	16.25	17.01	17.41	18.17	18.33	18.15	19.75	20.51	20.91	21.67	13.83	13.65	15.25	16.01	16.41	17.17
		MAX	15.97	15.79	17.29	18.05	18.42	19.18	19.47	19.29	20.79	21.55	21.92	22.68	14.97	14.79	16.29	17.05	17.42	18.18

Contact size	Ø A Max					
	CI (5mm contact length)		LI (8.5 mm contact length)		SI (4 mm contact length)	
	Gold plated contacts	Tin lead, Silver tin or Silver tin copper plated contacts	Gold plated contacts	Tin lead, Silver tin or Silver tin copper plated contacts	Gold plated contacts	Tin, tin lead, silver tin or silver tin copper plated contacts
23 ^{HD}	0.5	0.6	0.5	0.6	Not applicable, size 22 only	
22	0.5	0.6	0.7	0.8	0.7	0.8
20	0.7	0.8	0.7	0.8	Not applicable, size 22 only	
16	1.15	1.25	1.15	1.25	Not applicable, size 22 only	
12	1.7	1.8	1.7	1.8	Not applicable, size 22 only	

^{HD} High density

All dimensions are given for information only and are in mm, except as otherwise specified | *in mm: 1mm=0.03937 inch

Due to technical modifications, all information provided is subject to change without prior notice
Designed by Amphenol Socapex

MIL-DTL-38999 SERIES III & EN3645, TV/CTV - TV METAL SHELLS WEIGHTS

Weight, contacts included

In grams (ounces)

All weight measurements are for reference only, ± 15% average.

Arrangement	Wall mount Receptacle (00) / Military (D38999/20)				Jam nut Receptacle (07) / Military (D38999/24)				Plug (06) / Military (D38999/26)			
	Stainless steel		Aluminum		Stainless steel		Aluminum		Stainless steel		Aluminum	
	Pin	Socket	Pin	Socket	Pin	Socket	Pin	Socket	Pin	Socket	Pin	Socket
9-35 / A35	20.45 (.72)	22.22 (.78)	9.20 (.32)	10.70 (.37)	32.51 (1.15)	34.28 (1.21)	12.51 (.44)	14.28 (.50)	30.43 (1.07)	32.19 (1.14)	12.00 (.42)	13.11 (.46)
9-98 / A98	20.46 (.72)	22.04 (.78)	7.08 (.25)	8.66 (.31)	32.52 (1.15)	34.11 (1.20)	12.52 (.44)	14.11 (.50)	30.44 (1.07)	32.02 (1.13)	11.25 (.40)	13.11 (.46)
11-35 / B35	26.90 (.95)	30.62 (1.08)	10.30 (.36)	14.06 (.50)	40.55 (1.43)	44.32 (1.56)	16.83 (.59)	20.59 (.73)	35.38 (1.25)	39.14 (1.38)	15.06 (.53)	18.11 (.64)
11-98 / B98	26.90 (.95)	30.11 (1.06)	10.30 (.36)	13.52 (.48)	40.55 (1.43)	43.77 (1.54)	16.83 (.59)	20.05 (.70)	35.38 (1.25)	38.60 (1.36)	15.11 (.53)	17.81 (.63)
13-08 / C8	34.29 (1.21)	39.37 (1.39)	13.61 (.48)	18.69 (.66)	54.16 (1.91)	59.24 (2.09)	21.73 (.77)	26.81 (.95)	51.17 (1.80)	56.25 (1.98)	22.50 (.79)	27.58 (.97)
13-35 / C35	34.47 (1.22)	40.60 (1.43)	13.79 (.49)	19.91 (.70)	54.34 (1.92)	60.46 (2.13)	21.91 (.77)	28.03 (.99)	51.35 (1.81)	57.47 (2.03)	22.68 (.80)	24.02 (.85)
13-98 / C98	34.47 (1.22)	39.73 (1.40)	13.79 (.49)	19.05 (.67)	54.34 (1.92)	59.60 (2.10)	21.91 (.77)	27.17 (.96)	51.35 (1.81)	56.61 (2.00)	22.62 (.80)	27.94 (.99)
15-05 / D5	43.41 (1.53)	50.76 (1.79)	18.01 (.63)	25.36 (.90)	67.45 (2.38)	74.80 (2.64)	27.58 (.97)	34.93 (1.23)	64.36 (2.27)	72.17 (2.55)	27.31 (.96)	33.22 (1.17)
15-18 / D18	43.82 (1.55)	52.21 (1.84)	22.00 (.78)	26.81 (.95)	67.86 (2.39)	76.25 (2.69)	27.99 (.99)	36.38 (1.28)	64.77 (2.28)	73.16 (2.58)	27.71 (.98)	36.11 (1.27)
15-35 / D35	43.73 (1.54)	53.21 (1.88)	18.33 (.65)	27.81 (.98)	67.77 (2.39)	77.52 (2.73)	27.90 (.98)	37.65 (1.33)	64.68 (2.28)	74.43 (2.63)	34.53 (1.22)	37.38 (1.32)
17-06 / E6	60.92 (2.15)	73.44 (2.59)	26.54 (.94)	39.05 (1.38)	82.64 (2.91)	95.16 (3.36)	34.97 (1.23)	47.49 (1.67)	70.90 (2.50)	87.95 (3.10)	32.34 (1.14)	49.40 (1.74)
17-26 / E26	60.51 (2.13)	72.57 (2.56)	26.13 (.92)	38.19 (1.38)	82.24 (2.90)	94.30 (3.36)	34.56 (1.22)	46.63 (1.64)	70.49 (2.49)	82.55 (2.91)	31.93 (1.13)	37.83 (1.33)
17-35 / E35	60.55 (2.14)	75.52 (2.66)	26.17 (.92)	41.14 (1.45)	82.28 (2.90)	97.25 (3.43)	34.61 (1.23)	49.58 (1.75)	70.53 (2.49)	85.50 (3.02)	31.98 (1.13)	43.93 (1.55)
19-11 / F11	64.05 (2.26)	75.57 (2.67)	27.49 (.97)	41.19 (1.45)	97.39 (3.43)	111.08 (3.92)	41.73 (1.47)	55.43 (1.95)	84.50 (2.98)	98.20 (3.46)	38.19 (1.35)	51.89 (1.83)
19-32 / F32	62.05 (2.19)	77.29 (2.73)	27.67 (.98)	42.91 (1.51)	97.57 (3.44)	112.81 (3.98)	41.91 (1.48)	57.15 (2.02)	84.69 (2.99)	99.93 (3.52)	38.37 (1.35)	53.61 (1.89)
19-35 / F35	62.14 (2.19)	80.60 (2.84)	27.76 (.98)	46.22 (1.63)	97.66 (3.44)	116.12 (4.10)	42.00 (1.48)	60.46 (2.13)	84.78 (2.99)	103.24 (3.64)	38.46 (1.36)	56.93 (2.01)
21-11 / G11	77.84 (2.75)	98.20 (3.46)	37.10 (1.31)	57.47 (2.03)	112.58 (3.97)	132.95 (4.69)	51.39 (1.81)	71.76 (2.53)	97.66 (3.44)	118.02 (4.16)	49.17 (1.73)	71.76 (2.53)
21-16 / G16	75.93 (2.68)	94.03 (3.32)	35.20 (1.24)	53.30 (1.88)	110.68 (3.90)	128.77 (4.54)	49.49 (1.75)	67.59 (2.38)	95.75 (3.38)	113.85 (4.02)	47.26 (1.67)	65.68 (2.32)
21-35 / G35	75.61 (2.67)	99.20 (3.50)	34.88 (1.23)	58.47 (2.06)	110.36 (3.89)	133.95 (4.72)	49.17 (1.73)	72.76 (2.57)	95.44 (3.37)	119.02 (4.20)	46.95 (1.66)	63.24 (2.23)
21-41 / G41	75.89 (2.68)	95.25 (3.36)	35.15 (1.24)	54.52 (1.92)	110.63 (3.90)	130.00 (4.59)	49.44 (1.74)	68.81 (2.43)	95.71 (3.38)	101.47 (3.58)	47.22 (1.67)	52.98 (1.87)
23-21 / H21	86.05 (3.03)	109.50 (3.86)	41.10 (1.45)	64.55 (2.28)	120.11 (4.24)	143.56 (5.06)	55.11 (1.94)	78.56 (2.77)	107.50 (3.79)	130.95 (4.62)	54.48 (1.92)	77.93 (2.75)
23-35 / H35	85.73 (3.02)	114.67 (4.04)	40.78 (1.44)	69.72 (2.46)	119.79 (4.23)	148.73 (5.25)	54.79 (1.93)	83.73 (2.95)	107.18 (3.78)	136.12 (4.80)	54.16 (1.91)	73.96 (2.61)
23-53 / H53	82.19 (2.90)	110.77 (3.91)	41.28 (1.46)	70.35 (2.48)	120.29 (4.24)	144.83 (5.11)	55.29 (1.95)	79.83 (2.82)	107.68 (3.80)	132.22 (4.66)	54.66 (1.93)	79.20 (2.79)
25-04 / J4	97.84 (3.45)	127.01 (4.48)	49.08 (1.73)	81.69 (2.88)	136.21 (4.80)	165.20 (5.83)	62.41 (2.20)	92.08 (3.25)	119.70 (4.22)	148.82 (5.25)	62.73 (2.21)	92.31 (3.26)
25-19 / J19	100.11 (3.53)	133.99 (4.73)	51.35 (1.81)	85.23 (3.01)	138.48 (4.88)	172.41 (6.08)	64.68 (2.28)	98.61 (3.48)	121.97 (4.30)	155.90 (5.50)	65.00 (2.29)	98.93 (3.49)
25-20 / J20	108.27 (3.82)	133.67 (4.71)	57.19 (2.02)	88.24 (3.12)	145.80 (5.14)	171.17 (6.04)	70.53 (2.49)	100.42 (3.54)	125.73 (4.43)	151.10 (5.33)	64.01 (2.26)	85.56 (3.02)
25-35 / J35	97.57 (3.44)	132.27 (4.67)	48.81 (1.72)	83.51 (2.95)	135.94 (4.79)	170.64 (6.02)	62.14 (2.19)	96.84 (3.42)	119.43 (4.21)	154.13 (5.44)	62.46 (2.20)	97.16 (3.43)
25-61 / J61	97.25 (3.43)	127.14 (4.49)	48.99 (1.73)	78.38 (2.76)	135.62 (4.78)	165.52 (5.84)	61.82 (2.18)	91.72 (3.23)	119.11 (4.20)	149.00 (5.26)	62.14 (2.19)	92.03 (3.25)

MIL-DTL-38999 SERIES III & EN3645, TV/CTV - CTV COMPOSITE SHELLS WEIGHTS

Weight, contacts included

In grams (ounces)

All weight measurements are for reference only, ± 15% average.

Arrangement	Wall mount Receptacle (00) / Military D38999/20		Jam nut Receptacle (07) / Military D38999/24		Plug (06) / Military D38999/26	
	Pin	Socket	Pin	Socket	Pin	Socket
9-35 / A35	7.3 (.26)	8.8 (.31)	9.89 (.35)	12.51 (.44)	7.39 (.26)	8.49 (.30)
9-98 / A98	4.7 (.16)	6.3 (.22)	10.61 (.37)	13.15 (.46)	8.48 (.30)	6.63 (.23)
11-35 / B35	7.8 (.27)	11.6 (.41)	13.26 (.47)	17.03 (.60)	9.78 (.34)	12.99 (.46)
11-98 / B98	7.8 (.27)	11.0 (.39)	13.26 (.47)	16.49 (.58)	9.83 (.35)	12.64 (.45)
13-08 / C8	10.5 (.37)	15.6 (.55)	18.60 (.67)	23.68 (.83)	14.85 (.52)	16.87 (.60)
13-35 / C35	10.7 (.38)	16.8 (.59)	17.40 (.61)	23.52 (.83)	15.03 (.53)	18.52 (.65)
13-98 / C98	10.7 (.38)	15.9 (.56)	17.40 (.61)	22.66 (.80)	14.87 (.52)	20.29 (.71)
15-05 / D5	14.2 (.50)	21.6 (.76)	21.97 (.77)	29.32 (1.03)	18.29 (.64)	24.00 (.85)
15-18 / D18	18.2 (.64)	23.0 (.81)	24.22 (.85)	32.61 (1.15)	18.69 (.66)	23.27 (.82)
15-35 / D35	14.6 (.51)	24.0 (.85)	22.29 (.79)	32.04 (1.13)	25.40 (.90)	28.36 (1.00)
17-06 / E6	22.2 (.78)	34.7 (1.22)	28.18 (.99)	40.70 (1.44)	23.13 (.82)	40.19 (1.42)
17-26 / E26	21.7 (.77)	33.8 (1.19)	27.77 (.98)	39.84 (1.40)	22.73 (.80)	22.86 (.81)
17-35 / E35	21.8 (.77)	36.7 (1.3)	27.82 (.98)	42.79 (1.51)	22.77 (.80)	34.43 (1.21)
19-11 / F11	22.5 (.79)	36.2 (1.28)	34.11 (1.20)	47.81 (1.69)	27.31 (.96)	41.00 (1.45)
19-32 / F32	22.7 (.80)	37.9 (1.34)	34.29 (1.21)	49.54 (1.75)	27.49 (.97)	42.73 (1.51)
19-35 / F35	22.7 (.80)	41.2 (1.45)	34.39 (1.21)	52.85 (1.86)	27.58 (.97)	46.04 (1.62)
21-11 / G11	31.4 (1.11)	51.8 (1.83)	45.72 (1.61)	66.09 (2.33)	36.96 (1.30)	53.04 (1.87)
21-16 / G16	29.6 (1.04)	47.6 (1.68)	41.12 (1.45)	59.22 (2.09)	35.02 (1.23)	53.12 (1.87)
21-35 / G35	29.2 (1.03)	52.8 (1.86)	40.80 (1.44)	64.39 (2.27)	34.74 (1.22)	51.04 (1.80)
21-41 / G41	29.5 (1.04)	48.9 (1.72)	41.08 (1.45)	60.44 (2.13)	34.97 (1.23)	40.73 (1.434)
23-21 / H21	34.8 (1.23)	58.3 (2.05)	46.40 (1.64)	69.85 (2.46)	41.50 (1.47)	64.91 (2.29)
23-35 / H35	34.5 (1.22)	63.4 (2.24)	46.08 (1.63)	75.02 (2.65)	41.18 (1.45)	60.97 (2.15)
23-53 / H53	35.0 (1.23)	64.1 (2.26)	46.58 (1.64)	71.12 (2.51)	41.59 (1.47)	63.46 (2.24)
25-04 / J4	42.1 (1.49)	62.1 (2.19)	55.47 (1.96)	81.42 (2.87)	48.57 (1.71)	68.50 (2.41)
25-19 / J19	44.4 (1.57)	78.3 (2.76)	57.74 (2.04)	91.67 (3.23)	50.84 (1.79)	76.71 (2.71)
25-20 / J20	50.3 (1.77)	80.8 (2.85)	62.01 (2.19)	91.90 (3.24)	51.85 (1.83)	82.01 (2.90)
25-35 / J35	41.9 (1.48)	76.6 (2.70)	53.62 (1.90)	88.32 (3.11)	48.30 (1.70)	83.00 (2.93)
25-61 / J61	42.1 (1.48)	71.5 (2.52)	53.31 (1.88)	83.20 (2.93)	47.94 (1.69)	77.84 (2.75)

All dimensions are given for information only and are in mm, except as otherwise specified

Due to technical modifications, all information provided is subject to change without prior notice
Designed by Amphenol Socapex

MIL-DTL-38999 SERIES III & EN3645, TV/CTV - HERMETIC RECEPTACLES TV Y

Air leakage limited to $1 \cdot 10^{-7} \text{cm}^3/\text{s}$ under 1 bar of differential pressure.



Description

TV*S*Y and TV*S*YN hermetic receptacle dedicated to applications requiring low air leakage or high protection to contamination. Amphenol also offers MIL-DTL-38999 series III qualified hermetic receptacles.

Main features

OPTIONS

- 9 shell sizes and many contact arrangements.
- Pin contacts, solder cup termination.

MATERIAL

- Shell: Stainless steel only.
- Plating: Passivated or Nickel plated
- Contact plating: gold on active area.
- Insert: Glass sealed technology.

STANDARD

- D38999/21/23/25 QPL versions available

Amphenol Designations - TV Hermetic Receptacles

1.	2.	3.	4.	5.	
Series	Shell type	Material and platings	Contact arrangement	Contact gender	Keying
TV	PS02	Y	11-35	P	-

1. Shell type

PS02	Square flange receptacle (Box mount)
S07	Jam nut receptacle
SI	Solder mount receptacle

2. Material and platings

Shell material	Shell finish
Y	Passivated ✓
YN	Electrodeposited Nickel ✓

3. Contact arrangement

Refer to page 18 for contact arrangements - Arrangements available according to insert arrangement section pages 23 to 29 - TV & Y Identification letter

4. Contact gender

P	Solder cup pin (500 cycles)
---	-----------------------------

Hermetic receptacles are always delivered with pin contacts

5. Keying

Blank (for normal)	A	B	C	D	E
--------------------	---	---	---	---	---

Refer to page 28 for keying information

All dimensions are given for information only and are in mm, except as otherwise specified | *in mm: 1mm=0.03937 inch

Series III TV-CTV
Series II JT
Series I LJT
Accessories & tools
Assembly instructions

MIL-DTL-38999 SERIES III & EN3645, TV/CTV - HOW TO ORDER HERMETIC ^{TV} ^Y

Military Designations - DLA MIL-DTL-38999 SERIES III Hermetic Receptacles

	1.	2.	3.	4.	5.	6.
Series	Shell type	Material and platings	Shell size	Contact arrangement	Contact gender	Keying
D38999/	25	N	B	35	P	N

1. Shell type

21	Square flange receptacle (Box mount)
23	Jam nut receptacle
25	Solder mount receptacle

2. Material and platings

	Shell material	Shell finish
Y	Stainless steel	Passivated ✓
N		Electrodeposited Nickel ✓

3. Shell size

A	B	C	D	E	F	G	H	J
09	11	13	15	17	19	21	23	25

4. Contact arrangement

Refer to page 18 for contact arrangements - Arrangements available according to insert arrangement section pages 23 to 29 - ^Y Identification letter

5. Contact gender

P Solder cup pin contacts (500 cycles)
Hermetic receptacles are always delivered with pin contacts

6. Keying

N	A	B	C	D	E
(for normal)					

Refer to page 28 for keying information

Overall dimensions

Square flange - Box mount receptacle



AMPHENOL	MILITARY
TVPS02Y*	D38999/21Y*
TVPS02YN*	D38999/21N*

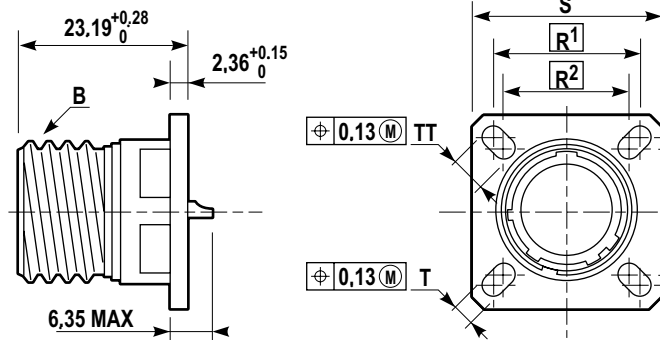

For panel hole dimensions, please refer to page 29.

Size		B thread class 2A 0.1P-0.3L-TS (inch)	S ±0.3	R ¹	R ²	T ±0.2	TT ±0.2
Amphenol	Military						
9	A	.6250	23.8	18.26	15.09	3.25	5.49
11	B	.7500	26.2	20.62	18.26	3.25	4.93
13	C	.8750	28.6	23.01	20.62	3.25	4.93
15	D	1.0000	31.0	24.61	23.01	3.25	4.39
17	E	1.1875	33.3	26.97	24.61	3.25	4.93
19	F	1.2500	36.5	29.36	26.97	3.25	4.93
21	G	1.3750	39.7	31.75	29.36	3.25	4.93
23	H	1.5000	42.9	34.93	31.75	3.91	6.15
25	J	1.6250	46.0	38.10	34.93	3.91	6.15

All dimensions are given for information only and are in mm, except as otherwise specified | *in mm: 1mm=0.03937 inch

Due to technical modifications, all information provided is subject to change without prior notice
Designed by Amphenol Socapex

MIL-DTL-38999 SERIES III & EN3645, TV/CTV - HERMETIC RECEPTACLES TV Y

Jam nut receptacle



AMPHENOL	MILITARY
TVS07Y*	D38999/23Y*
TVS07YN*	D38999/23N*

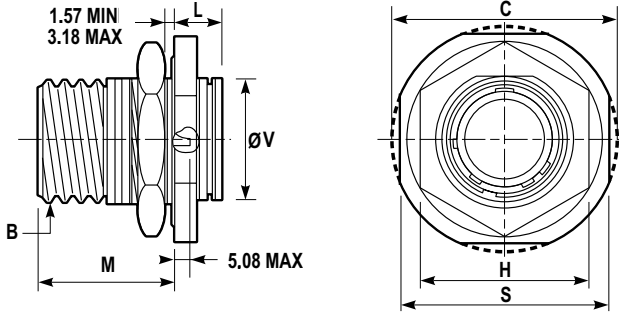

For panel drilling, please refer to page 31.

Size		B thread class 2A 0.1P-0.3L-TS (inch)	ØV ^{+0.28} -0	M	L _{Max}	C _{MAX}	S ±0.4	H ±0.4	Hex nut torque value N.m _{MIN/MAX}
Amphenol	Military								
9	A	.6250	16.31	22.12	9.07	30.5	27.0	22.2	4.1
11	B	.7500	19.46	22.12	9.07	35.2	31.7	25.4	5.3
13	C	.8750	22.66	22.30	9.07	38.4	34.9	30.2	6.9
15	D	1.0000	25.86	22.30	9.07	41.6	38.1	33.3	8.6
17	E	1.1875	29.01	22.30	9.07	44.7	41.3	36.5	9.8
19	F	1.2500	32.21	22.30	9.68	49.5	46.0	39.7	10.9
21	G	1.3750	35.36	22.30	9.68	52.7	49.2	42.9	12.7
23	H	1.5000	38.56	22.30	9.68	55.9	52.4	46.0	13.8
25	J	1.6250	41.71	22.30	9.68	59.0	55.6	50.8	15

Solder mount receptacle



AMPHENOL	MILITARY
TVSIY	D38999/25Y
TVSIYN	D38999/25N

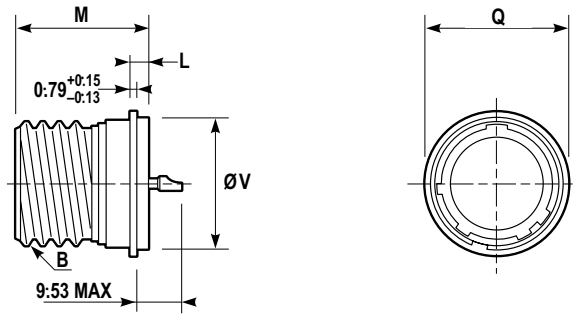

For panel drilling, please refer to page 31.

Size		B thread class 2A 0.1P-0.3L-TS (inch)	ØV ^{+0.03} -0.13	M ^{+0.28} -0	L ^{+0.15} -0.13	ØQ ^{+0.28} -0.25
Amphenol	Military					
9	A	.6250	17.07	20.47	3.18	19.05
11	B	.7500	19.84	20.47	3.18	21.44
13	C	.8750	23.01	20.47	3.18	24.61
15	D	1.0000	26.19	20.47	3.18	27.79
17	E	1.1875	29.36	20.47	3.18	30.94
19	F	1.2500	31.75	20.47	3.18	33.32
21	G	1.3750	34.93	20.47	3.18	36.53
23	H	1.5000	38.10	21.29	3.96	39.70
25	J	1.6250	41.28	21.29	3.96	42.88

All dimensions are given for information only and are in mm, except as otherwise specified | *in mm: 1mm=0.03937 inch

Series III TV-CTV
Series II JT
Series I LJT
Accessories & tools
Assembly instructions

MIL-DTL-38999 SERIES III & EN3645, TV/CTV - LANYARD RELEASE PLUGS ^L

TV breakaway fail-safe lanyard release plug.

Description

The TV Breakaway fail-safe connectors allows a quick disconnection with an axial pull of lanyard. This range offers unequaled performances in environments requiring instant disengagement. Amphenol is qualified to provide D38999/29, /30, and /31 Types 1, 2, and 6 breakaway connectors.



Main features

INSTANT DISENGAGEMENT & TRI-START THREAD COUPLING

INSTANT DECOUPLING AND DAMAGE FREE SEPARATION

2 UNMATING POSSIBILITIES

- Applying a pull force to the lanyard.
- Rotation of the coupling ring.

AXIAL PULL OF THE LANYARD: 15° MISALIGNMENT

MATERIAL

- Shell: Aluminum.
- Plating: Olive drab cadmium, Black Zinc Nickel or Nickel.

COMPLETELY INTERMATEABLE WITH STANDARD RECEPTACLES (D38999/20 & /24)

D38999/29 & D38999/30 WITH CONTACTS ARRANGEMENTS AVAILABLE FROM SIZE 11 TO 25 ^L (see page 18 to 29)

D38999/31 WITH TWO DEDICATED CONTACTS ARRANGEMENTS (MIL-STD-1760 - Stores management applications)

- Pin only.
- 25-11 or 25-20 contact arrangements.
- Type 1, 2 or 6 upon request.
- Olive drab cadmium only.

Options

Pin lanyard release plug
D38999/29



Socket lanyard release plug
D38999/30



Pin lanyard release plug for MIL-STD-1760
D38999/31



Arrangements

MIL-DTL-38999/29 or 30

Please refer to insert arrangement table pages 20 & 21 and to insert arrangement section pages 22 to 29 identified with a ^L.

Consult us for Amphenol version, sizes 11 to 15. (not QPL)

MIL-DTL-38999/31 (dedicated to MIL-STD-1760 applications)

TV-CTV	25-11		25-20			
MIL-DTL-38999 Series III	J11		J20			
Total contacts	2	9	10	13	4	3
Contact size	20	10 power	20	16	12 Coax	8 Twinax

All dimensions are given for information only and are in mm, except as otherwise specified | *in mm: 1mm=0.03937 inch

Due to technical modifications, all information provided is subject to change without prior notice
 Designed by Amphenol Socapex

MIL-DTL-38999 SERIES III & EN3645, TV/CTV - HOW TO ORDER LANYARD RELEASE ^L

Military Designations - DLA MIL-DTL-38999 SERIES III Lanyard Release Plugs

1.	2.	3.	4.	5.	6.	
Series	Shell type	Material and platings	Shell size	Contact arrangement	Lanyard length	Keying
D38999/	29	F	E	26	M	N

1. Shell type

29	Lanyard release plug with pin contacts
30	Lanyard release plug with socket contacts

Lanyard release plugs are always delivered with contacts

2. Material and platings

Shell material		Shell finish
W	Aluminum	Olive drab cadmium
Z		Black Zinc Nickel ✓
F		Electroless Nickel ✓

3. Shell size

B	C	D	E	F	G	H	J
11	13	15	17	19	21	23	25

4. Contact arrangement

Refer to page 18 for contact arrangements - Arrangements available according to insert arrangement section pages 23 to 29 - ^L Identification letter

5. Lanyard length

Please refer to the table besides

6. Keying

^N (for normal) N coding only

Code	Lanyard length mm ±6.0 (in. ±0.24)
A	102 (4.0)
B	115 (4.5)
C	127 (5.0)
D	140 (5.5)
E	153 (6.0)
F	166 (6.5)
G	178 (7.0)
H	191 (7.5)
I	203 (8.0)
J	216 (8.5)
K	229 (9.0)
L	242 (9.5)
M	254 (10.0)
N	267 (10.5)
P	280 (11.0)
R	293 (11.5)
S	305 (12.0)
T	318 (12.5)
U	331 (13.0)
V	356 (13.5)
W	381 (14.0)
X	407 (14.5)
Y	432 (15.0)
Z	458 (15.5)

Military Designations - DLA MIL-DTL-38999 SERIES III Lanyard Release Plugs for MIL-STD-1760 Applications

1.	2.	3.	4.	5.	6.	7.	
Series	Shell type	Material and platings	Lanyard length code	Contact arrangement	Contact type	Keying	Shell design
D38999/	31	F	E	20	P	N	1

1. Shell type

31	Lanyard release plug for MIL-STD-1760 with pin contacts
----	---

2. Material and platings

Shell material		Shell finish
W	Aluminum	Olive Drab Cadmium
F		Electroless Nickel ✓

3. Lanyard length code

Code	Lanyard length - mm ±6.0 (in. ±.24)
E	153 (6.0)
F	166 (6.5)
G	178 (7.0)
H	191 (7.5)
I	203 (8.0)
J	216 (8.5)
K	229 (9.0)
L	242 (9.5)

4. Contact arrangement

11	25-11 contact arrangement
20	25-20 contact arrangement

5. Contact type

P	Pin (500 cycles)
A	Delivered without pin contacts

Pin contacts only

6. Keying

^N (for normal) N coding only

7. Shell design

Shell length	
1	Long length 63.5mm max (in.2.5max)
6	Medium length 51.56mm max (in.2.0max)

✓: RoHS compliant

All dimensions are given for information only and are in mm, except as otherwise specified | *in mm: 1mm=0.03937 inch

Series III TV-CTV
Series II JT
Series I LJT
Accessories & tools
Assembly instructions

MIL-DTL-38999 SERIES III & EN3645, TV/CTV - HOW TO ORDER LANYARD RELEASE

Amphenol Designations - Lanyard Release Plugs for MIL-STD-1760 Applications

1.	2.	3.	4.	5.	
Series	Material and platings	Contact arrangement	Contact gender	Keying	Lanyard length
TVFBR	W	25-20	P	N	B

1. Material and platings

	Shell material	Shell finish
W	Aluminum	Olive drab cadmium
F		Electroless Nickel ✓

2. Contact arrangement

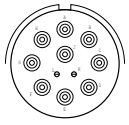
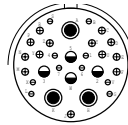
Insert	25-11		25-20			
Layout						
Total contacts	2	9	10	13	4	3
Contact size	20	10 power	20	16	12 Coax	8 Twinax

3. Contact type

P	Pin contacts only (500 cycles)
---	--------------------------------

4. Keying

N	N coding only
(for normal)	

5. Lanyard length

Code	Lanyard length ± 6.0mm (inch ±24)
A	102.0 (4.0)
B	115.0 (4.5)
C	127.0 (5.0)
D	140.0 (5.5)
E	153.0 (6.0)
F	166.0 (6.5)
G	178.0 (7.0)
H	191.0 (7.5)
I	203.0 (8.0)
J	216.0 (8.5)
K	229.0 (9.0)
L	242.0 (9.5)

For other lengths, please consult us

✓ : RoHS compliant

All dimensions are given for information only and are in mm, except as otherwise specified | *in mm: 1mm=0.03937 inch

MIL-DTL-38999 SERIES III & EN3645, TV/CTV - LANYARD RELEASE PLUGS L

Overall dimensions

Lanyard release plug /29 /30

D38999/29: plug with pin contacts.
 D38999/30: plug with socket contacts.

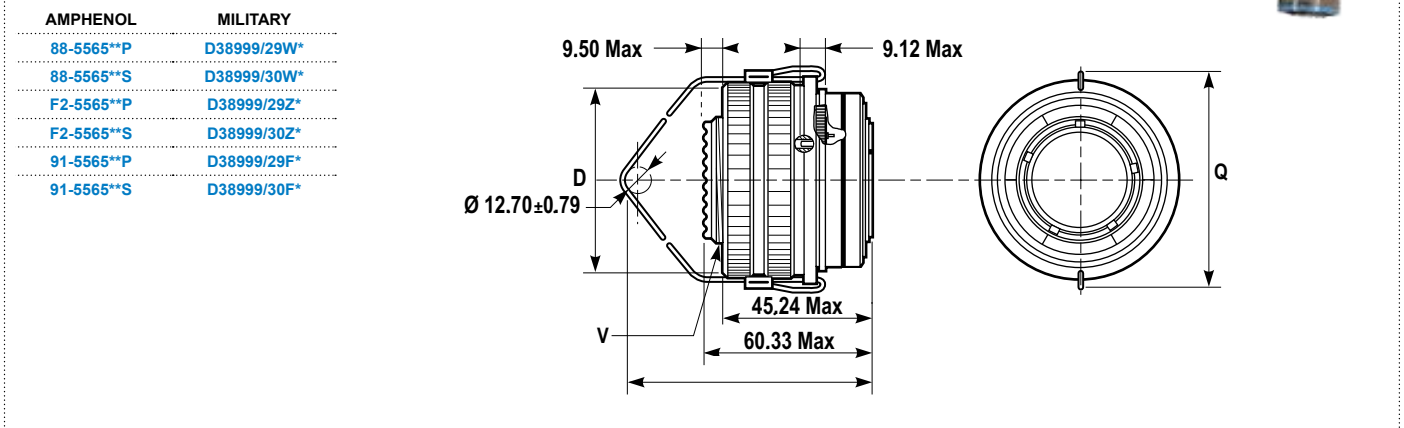

Size		V thread-metric	D _{MAX}	Q _{MAX}
Military	Amphenol			
E	17	M25X1.0-6g	38.10	56.01
F	19	M28X1.0-6g	41.28	58.45
G	21	M31X1.0-6g	44.45	62.79
H	23	M34X1.0-6g	47.63	65.89
J	25	M37X1.0-6g	50.08	68.71

Lanyard length code for part number	A	B	C	D	E	F	G	H	I	J	K	L	M	N	P	R	S	T	U	V	W	X	Y	Z
X ±6	102	115	127	140	153	166	178	191	203	216	229	242	254	267	280	293	305	318	331	356	381	407	432	458

Lanyard release plug /31, for MIL-STD-1760 applications

D38999/31: plug with pin contacts.

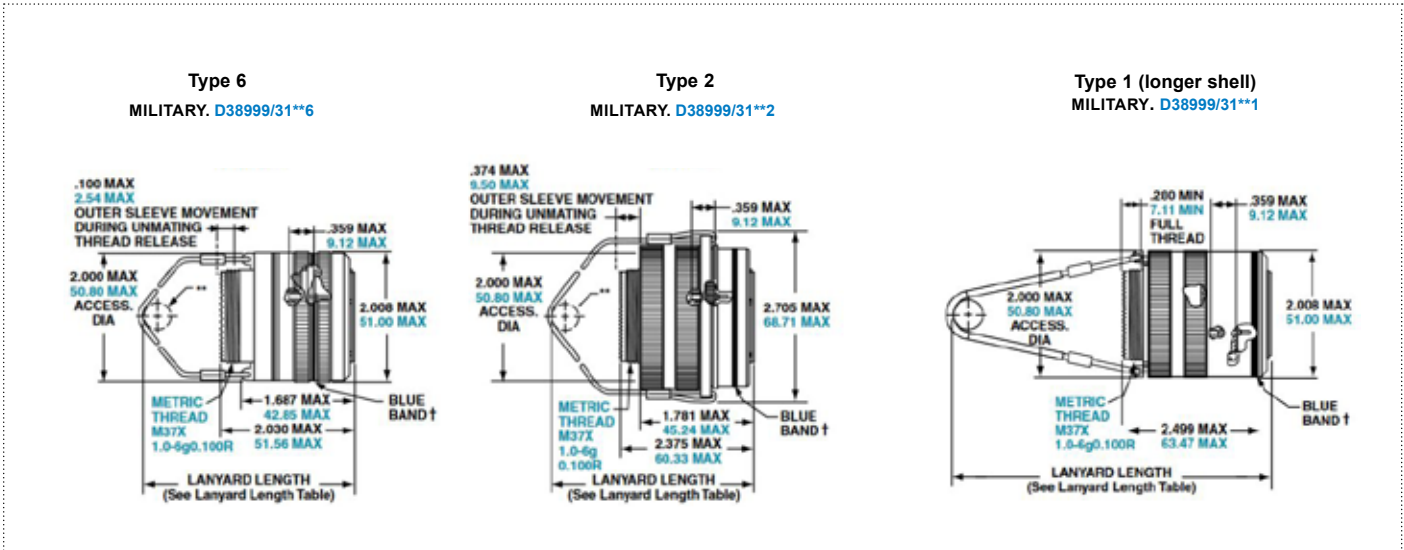

Lanyard length code for part number	E	F	G	H	I	J	K	L
X ±6	153	166	178	191	203	216	229	242

All dimensions are given for information only and are in mm, except as otherwise specified | *in mm: 1mm=0.03937 inch

Series III TV-CTV
Series II JT
Series I LJT
Accessories & tools
Assembly instructions

NOTES

Area with horizontal dotted lines for notes.

All dimensions are given for information only and are in mm, except as otherwise specified | *in mm: 1mm=0.03937 inch

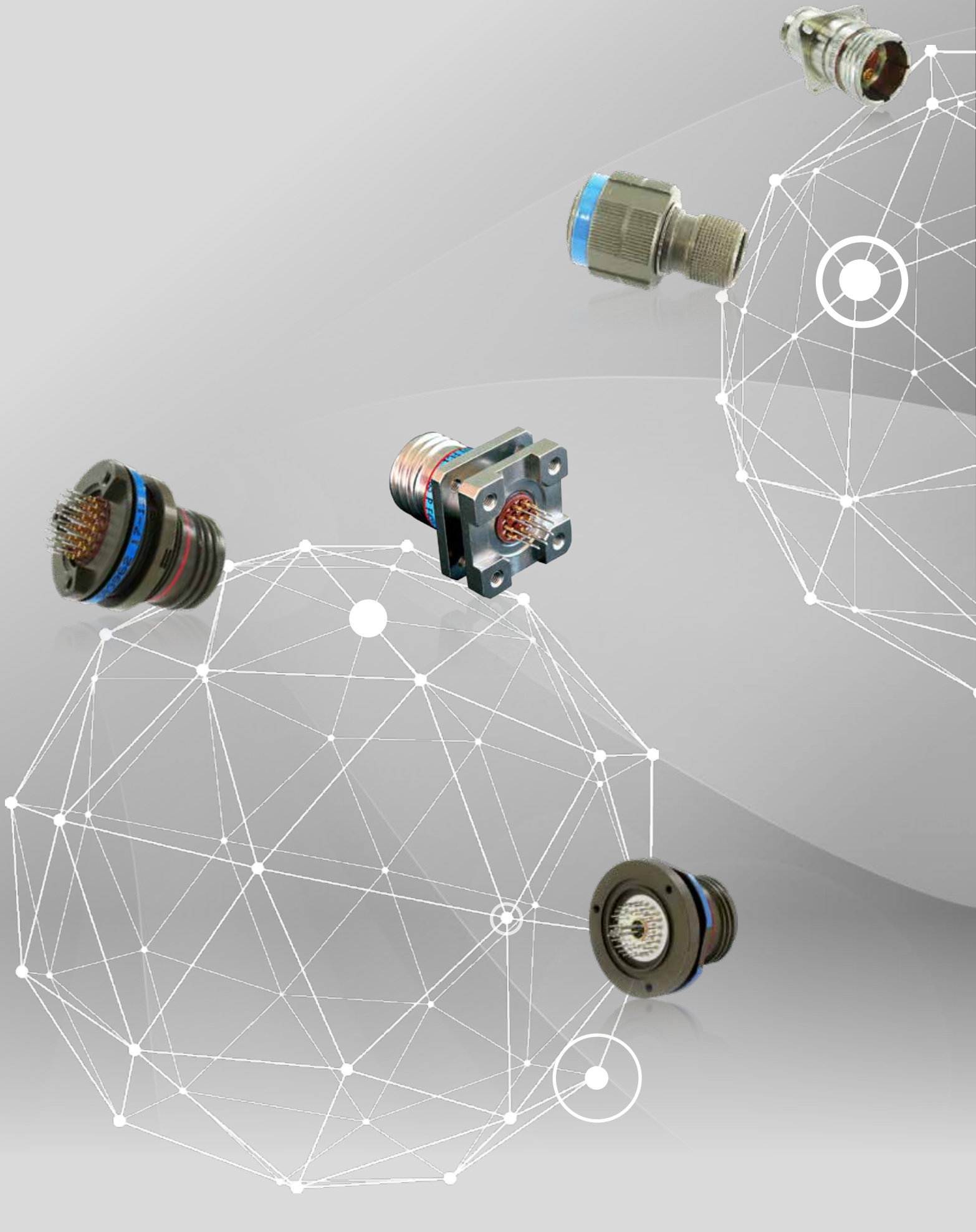







MIL-DTL-38999 SERIES III EXTENDED RANGE



Table of contents

EXTENDED RANGE	77
Connectors with integrated backshells - F472	78
Square flange receptacles equipped with clinch nuts - F506	83
Stand-off Double flange receptacles - F459	85
Reduced flange receptacles - F312 & F059	87
Enhanced sealing receptacles - ETC ETCI ETLI	91
Thru-bulkhead receptacles - TVB	93

THE EXTENDED RANGE SERVES VARIOUS MARKETS, INCLUDING:

- 
 Commercial Avionics & Airframe
- 
 Military Avionics & Airframe
- 
 Military vehicles
- 
 C4ISR
- 
 Missiles
- 
 Navy
- 
 Industrial

All dimensions are given for information only and are in mm, except as otherwise specified | *in mm: 1mm=0.03937 inch

Due to technical modifications, all information provided is subject to change without prior notice
 Designed by Amphenol Socapex

MIL-DTL-38999 SERIES III EXTENDED RANGE - INTEGRATED BACKSHELL

All-in-one connectors : D38999 style connector with integrated backshells

Description

TV series with integrated backshell are available in plugs and receptacles versions. These lightweight and low profile solutions offer EMI performance and save time during the installation.

Main features

- Derived from MIL-DTL-38999 Series III connectors.
- Available on plugs and receptacles.
- Available with power and high-speed contacts.
- All-in-one product: time saving during order and installation.
- Total length saving: Average -47% vs standard plug with TV35 backshell.
- Average 50% lighter vs standard plug with TV35 backshell.
- High EMI Protective.
- Braid clamping (metal Band-it).
- Available materials/plating:
 - Aluminum (Olive drab cadmium, Nickel, Black zinc nickel, Tin Zinc)
 - Marine bronze
 - Stainless steel (Passivated)



Integrated backshell :

Standard combo standard plug + backshell (TV35)



Integrated backshell plug (F472)



Amphenol Designations - Integrated Backshell Connectors

1.	2.	3.	4.	5.	6.	7.	8.	9.	10.
Series	Shell type	Crimp contacts	Ground plane and Quadrax	Material and platings	Contact arrangement	Contact gender	Keying	With or without contacts	Deviation
TV	06	R	Q	W	17-02	P	A	LC	F472

1. Series

TV Metal shells (Aluminum, Stainless Steel, Marine Bronze)

2. Shell type

	Shell type	Associated materials and platings	Temperature
P00	Square flange - Wall mount receptacle	W, ZN, ZR, TZ	+175°C
PS00 *		F, K, S, B	+200° C *
07	Jam nut receptacle	W, ZN, ZR, TZ	+175°C
S07 *		F, K, S, B	+200° C *
06	Straight plug	W, ZN, ZR, TZ	+175°C
S06 *		F, K, S, B	+200° C *

* «S» Stand for 200°C compatibility. Omit for High-density inserts , inserts with Quadrax contacts and differential Twinax contacts are +175°C maxi compatible.

3. Crimp contacts

R	For W, F, Z, K, S and B materials & platings (ex: TV06RW1535P)
Blank	For ZN, ZR and TZ platings (ex: TV06ZN1535P)

4. Conductive inserts & inserts for Quadrax and differential Twinax contacts (optional)

Conductive inserts are available for Aluminum versions with Olive Drab Cadmium, Tin Zinc and Electroless Nickel. For any others materials and platings please consult us.

Blank	For standard inserts without ground plane and indexation key.
G	Ground Plane version - Conductive insert. Mandatory for 09-05*.
Q	Inserts designed with an indexation key to avoid contacts rotation in the cavities when using a keyed contact - Size 8 contacts only.
GQ	Ground plane version with insert designed with an indexation key.

* Please note that 09-05 insert is automatically conductive. Add the 'G' letter in all your references for this arrangement.

5. Material and platings

W		Olive Drab Cadmium
F		Electroless Nickel
ZN	Aluminum	Black Zinc Nickel
ZR		Black Zinc Nickel CrVI free
TZ		Tin Zinc
K	Stainless steel	Passivated
S		Electrodeposited Nickel (consult us for availability)
B	Marine Bronze*	-

* Copper aluminum alloy

6. Contact arrangement

Refer to page 18 for contact arrangements. First number represents the shell size and second number is the contact arrangement.

7. Contact gender

P	Pin (500 cycles)
S	Socket (500 cycles)

8. Keying

Blank (for normal)	A	B	C	D	E	U (Universal) Consult us
------------------------------	----------	----------	----------	----------	----------	---------------------------------------

Refer to page 28 for more information.

9. With or without contacts

Blank	Connector delivered with contacts
LC	Connector delivered without contacts

10. Deviation

Deviation	Description	Shell type compatibility
F472	Integrated backshell Band-it width 6mm ±0.2	TV*06
F472K	Integrated backshell (mandatory for stainless steel) Band-it width 6mm ±0.2	TV*07 TVP*00
F472A	Integrated backshell Band-it width 3mm ±0.5	TV*01

All dimensions are given for information only and are in mm, except as otherwise specified | *in mm: 1mm=0.03937 inch

MIL-DTL-38999 SERIES III EXTENDED RANGE - HOW TO ORDER - INTEGRATED BACKSHELL

Overall dimensions Square flange - Wall mount receptacle



TVP*00*F472
TVP*00**F472K

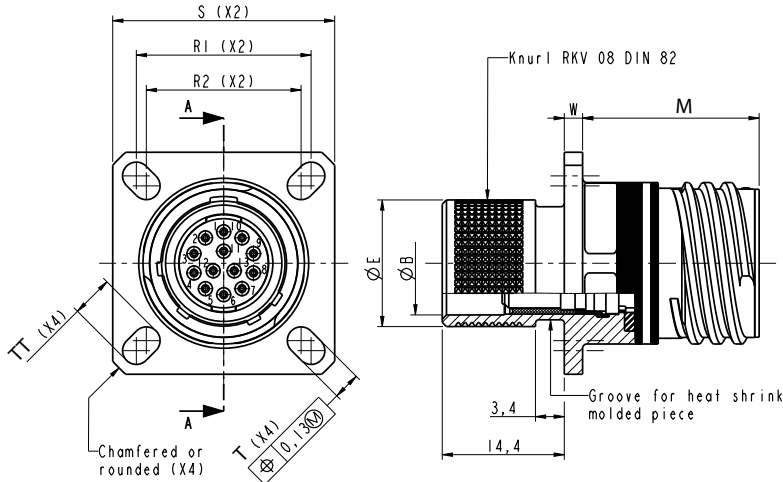

For band-it width 6mm

Size	S ±0.3	R1	R2	TT ±0.2	T ±0.2	ØE _{MAX}	ØB	W	M ^{0 -0.13}
9	23.8	18.26	15.09	5.49	3.25	12	9.0	2.5	20.83
11	26.2	20.62	18.26	4.93	3.25	15	12.2	2.5	20.83
13	28.6	23.01	20.62	4.93	3.25	18	15.1	2.5	20.83
15	31.0	24.61	23.01	4.39	3.25	22	18.3	2.5	20.83
17	33.3	26.97	24.61	4.93	3.25	25	21.5	2.5	20.83
19	36.5	29.36	26.97	4.93	3.25	28	24.2	2.5	20.83
21	39.7	31.75	29.36	4.93	3.25	31	27.3	3.2	20.07
23	42.9	34.93	31.75	6.15	3.91	34	30.5	3.2	20.07
25	46.0	38.10	34.93	6.15	3.91	37	33.7	3.2	20.07

All dimensions are given for information only and are in mm, except as otherwise specified | *in mm=0.03937 inch

Due to technical modifications, all information provided is subject to change without prior notice
Designed by Amphenol Socapex

MIL-DTL-38999 SERIES III EXTENDED RANGE - INTEGRATED BACKSHELL

Jam nut receptacle

TVP*00*F472
TV*07**F472K

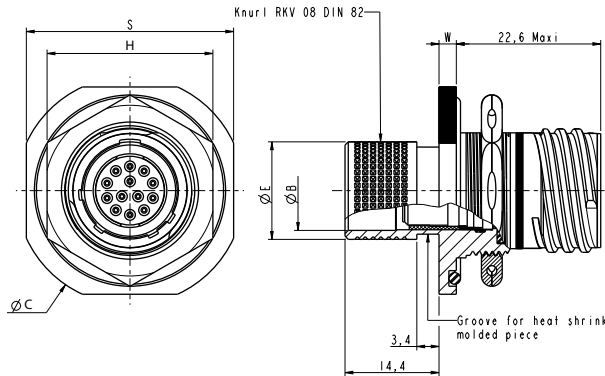

For band-it width 6mm

Size	ØC ±0.3	S ±0.4	H ±0.4	ØE MAX	ØB	W +0.3 -0.1
9	30.5	27.0	22.2	12	9.0	2.2
11	35.2	31.8	25.4	15	12.2	2.2
13	38.4	34.9	30.2	18	15.1	2.2
15	41.6	38.1	33.3	22	18.3	2.2
17	44.8	41.3	36.5	25	21.5	2.2
19	49.5	46.0	39.7	28	24.2	3.0
21	52.7	49.2	42.9	31	27.3	3.0
23	55.9	52.4	46.0	34	30.5	3.0
25	59.0	55.6	50.8	37	33.7	3.0

Straight plug

TV*06*F472
TV*06**F472K

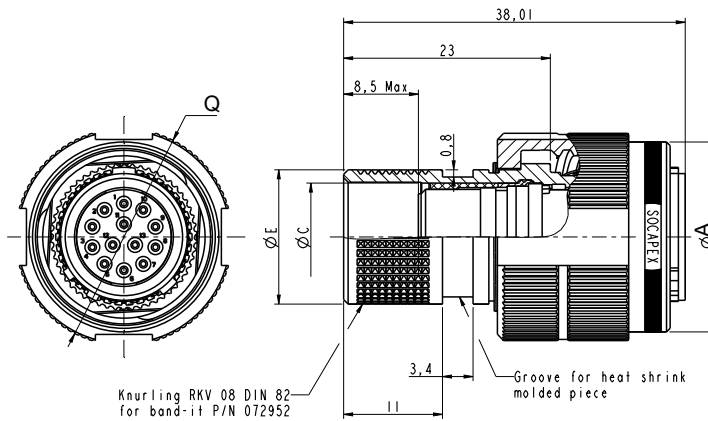

For band-it width 6mm

Size	ØQ MAX	ØE MAX	ØA +0.2 0	ØC
9	21.8	12	18.4	8.74
11	25.0	15	21.1	11.99
13	29.4	18	25.4	14.88
15	32.5	22	28.7	18.06
17	35.7	25	32.2	21.23
19	38.5	28	34.9	23.93
21	41.7	31	38.1	27.1
23	44.9	34	41.1	30.28
25	48.0	37	44.3	33.45

All dimensions are given for information only and are in mm, except as otherwise specified | *in mm: 1mm=0.03937 inch

Due to technical modifications, all information provided is subject to change without prior notice
Designed by Amphenol Socapex

MIL-DTL-38999 SERIES III EXTENDED RANGE - INTEGRATED BACKSHELL

Version for μ Band-it - width 3mm Square flange - Wall mount receptacle



TVP*00**F472A

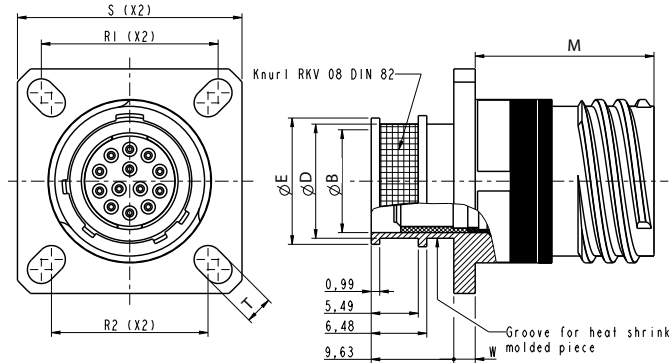

For band-it width 3mm
F472A deviation include insertion removal tool and 10% more contact.

Size	S ± 0.3	R1	R2	T ± 0.2	$\varnothing E$ $\begin{smallmatrix} +0.08 \\ -0.05 \end{smallmatrix}$	$\varnothing D$ $\begin{smallmatrix} +0.13 \\ 0 \end{smallmatrix}$	$\varnothing B$	W MAX	M $\begin{smallmatrix} +0 \\ -0.13 \end{smallmatrix}$
9	23.8	18.26	15.09	3.25	12	10.57	8.74	2.5	20.83
11	26.2	20.62	18.26	3.25	15	13.31	11.99	2.5	20.83
13	28.6	23.01	20.62	3.25	18	16.56	14.88	2.5	20.83
15	31.0	24.61	23.01	3.25	22	20.57	18.06	2.5	20.83
17	33.3	26.97	24.61	3.25	25	23.57	21.23	2.5	20.83
19	36.5	29.36	26.97	3.25	28	26.57	23.93	2.5	20.83
21	39.7	31.75	29.36	3.25	31	29.57	27.1	3.2	20.07
23	42.9	34.93	31.75	3.91	34	32.56	30.28	3.2	20.07
25	46.0	38.1	34.93	3.91	37	35.56	33.45	3.2	20.07

Jam nut receptacle



TV*07**F472A

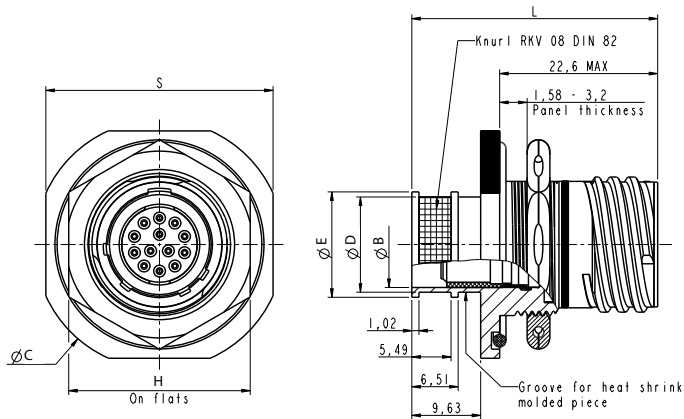

For band-it width 3mm
F472A deviation include insertion removal tool and 10% more contact.

Size	$\varnothing C$	S ± 0.4	H ± 0.4	$\varnothing E$ MAX	$\varnothing D$ $\begin{smallmatrix} +0.13 \\ 0 \end{smallmatrix}$	$\varnothing B$	L MAX
9	30.5	27.0	22.2	12	10.57	8.74	34.64
11	35.2	31.8	25.4	15	13.31	11.99	34.64
13	38.4	34.9	30.2	18	16.56	14.88	34.81
15	41.6	38.1	33.3	22	20.57	18.06	34.81
17	44.8	41.3	36.5	25	23.57	21.23	34.81
19	49.5	46.0	39.7	28	26.57	23.93	35.63
21	52.7	49.2	42.9	31	29.57	27.1	35.63
23	55.9	52.4	46.0	34	32.56	30.28	35.63
25	59.0	55.6	50.8	37	35.56	33.45	35.63

All dimensions are given for information only and are in mm, except as otherwise specified | *in mm: 1mm=0.03937 inch

Due to technical modifications, all information provided is subject to change without prior notice
Designed by Amphenol Socapex

MIL-DTL-38999 SERIES III EXTENDED RANGE - INTEGRATED BACKSHELL

Straight plug



TV*06**F472A

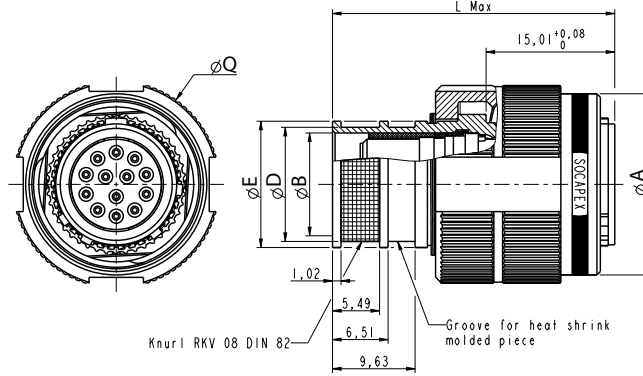

For band-it width 3mm
F472A deviation include insertion/removal tool and 10% more contact.

Size	ØQ _{MAX}	ØE _{MAX}	ØD ^{+0.13} ₀	ØB	L _{MAX}	ØA ^{+0.2} ₀
9	21.8	12	10.57	8.74	32.95	18.4
11	25.0	15	13.26	11.99	32.95	21.1
13	29.4	18	16.56	14.88	32.95	25.4
15	32.5	22	20.57	18.06	33.1	28.7
17	35.7	25	23.57	21.23	33.25	32.2
19	38.5	28	26.57	23.93	33.25	34.9
21	41.7	31	29.57	27.1	33.41	38.1
23	44.9	34	32.56	30.28	33.41	41.1
25	48.0	37	35.56	33.45	33.41	44.3

Recommended Heatshrink boot

Size	Rear size Ø	Minimum Cable Ø	Straight Raychem reference	Right Angled Raychem reference
9	12	5.6	202K121	222K121
		5.6	202K121	222K121
11	15	5.9	202K132	222K132
		5.6	202K121	222K121
13	18	5.9	202K132	222K132
		7.1	202K142	222K142
		5.9	202K132	222K132
15	22	7.1	202K142	222K142
		8.4	202K132	222K132
		7.1	202K142	222K142
17	25	8.4	202K153	222K153
		7.1	202K142	222K142
19	28	8.4	202K153	222K153
		8.4	202K153	222K153
21	31	8.4	202K153	222K153
		9.9	202K163	222K163
23	34	8.4	202K153	222K153
		9.9	202K163	222K163
25	37	8.4	202K153	222K153

All dimensions are given for information only and are in mm, except as otherwise specified | *in mm: 1mm=0.03937 inch

Due to technical modifications, all information provided is subject to change without prior notice
Designed by Amphenol Socapex

Series III TV-CTV
Series II JT
Series I LJT
Accessories & tools
Assembly instructions

MIL-DTL-38999 SERIES III EXTENDED RANGE - SHELL WITH CLINCH NUTS

Clinch nut self-locking system for time savings

Description

Square flange receptacles equipped with clinch nuts to ease and save time during the connector integration on panel. The self-locking system enables to block and hold the screw.

Main features

- Easy to install, time saving.
- No more nut and washer.
- Anti-decoupling.
- Back panel mounting.

Clinch nut



OPTIONS

- Shell style: Square flange - Wall mount or Box mount receptacle.
- Material: Aluminum with Olive drab cadmium, Nickel & Tin Zinc plating.
- PCB contacts CI or LI. Crimp contacts upon request.
- PCB termination plating : Gold, Tin lead, Silver tin or Silver tin copper.
- Please consult us for other configuration.

Amphenol Designations - Clinch nuts connectors

1.	2.	3.	4.	5.	6.	7.	8.	9.
Series	Shell type	Ground plane and Quadrax	Material and platings	PC Tail contacts	Contact arrangement	Contact gender	Keying	Deviation
TV	P00	Q	W	CI	17-02	P	A	F506

1. Series

TV Aluminum shells

2. Shell type

	Shell type	Associated materials and platings	Temperature
P00	Square flange - Wall mount receptacle	W, ZN, ZR, TZ	+175°C
PS00*	Square flange - Wall mount receptacle	F, K, S, B	+200°C*
P02	Square flange - Box mount receptacle (no rear thread)	W, ZN, ZR, TZ	+175°C
PS02*	Square flange - Box mount receptacle (no rear thread) (non-standard shells, please consult us)	F, K, S, B	+200°C*
07	Jam nut receptacle	W, ZN, ZR, TZ	+175°C
S07*	Jam nut receptacle	F, K, S, B	+200°C*
01	In-line receptacle	W, ZN, ZR, TZ	+175°C
S01*	In-line receptacle (non-standard shells, please consult us)	F, K, S, B	+200°C*
06	Straight plug	W, ZN, ZR, TZ	+175°C
S06*	Straight plug	F, K, S, B	+200°C*

* «S» Stand for 200°C compatibility. Omit for High-density inserts ☺, inserts with Quadrax contacts and differential Twinax contacts ☹ are +175°C maxi compatible.

3. Conductive inserts & inserts for Quadrax and differential Twinax contacts (optional)

Conductive inserts are available for Aluminum versions with Olive Drab Cadmium, Tin Zinc and Electroless Nickel. For any others materials and platings please consult us.

Blank	For standard inserts without ground plane and indexation key.
G	☺ Ground Plane version - Conductive insert. Mandatory for 09-05*.
Q	☹ Inserts designed with an indexation key to avoid contacts rotation in the cavities when using a keyed contact - Size 8 contacts only.
GQ	☺☹ Ground plane version with insert designed with an indexation key.

* Please note that 09-05 insert is automatically conductive. Add the 'G' letter in all your references for this arrangement.

4. Material and platings

W	Olive Drab Cadmium
F	Aluminum Electroless Nickel ✓
TZ	Tin Zinc ✓
ZN	Black Zinc Nickel ✓
ZR	Black Zinc Nickel CrVI free ✓

5. PC Tail contacts

CI	Standard length (5 mm)
LI	Long length (8.5 mm)
SI	Short length (size 22D contacts only) (4 mm) For shorter contacts on box mount receptacles (P02 and PS02), please consult us.

For shorter contacts on box mount receptacles (P02 and PS02), please consult us.

6. Contact arrangement

Refer to page 18 for contact arrangements. First number represents the shell size and second number is the contact arrangement.

7. Contact gender

P	Pin (500 cycles)
S	Socket (500 cycles)
H	Pin (1500 cycles. CTV only)
J	Socket (1500 cycles. CTV only)

8. Keying

Blank (for normal)	A	B	C	D	E	U (Universal) Consult us
--------------------	---	---	---	---	---	--------------------------

Refer to page 28 for more information.

9. Deviation

Shell style	PC Tail finish / Tinning				Shell type compatibility
	Tin lead	Silver tin ✓	Silver tin copper ✓	Gold ✓	
Equipped with clinch nuts	F506G	F506LF	F506LFC	F506	TVP*00 TVP*02 Aluminum shell

All dimensions are given for information only and are in mm, except as otherwise specified | *in mm: 1mm=0.03937 inch

MIL-DTL-38999 SERIES III EXTENDED RANGE - HOW TO ORDER - CLINCH NUTS

Overall dimensions

Square flange - Wall mount receptacle



Square flange - Box mount receptacle

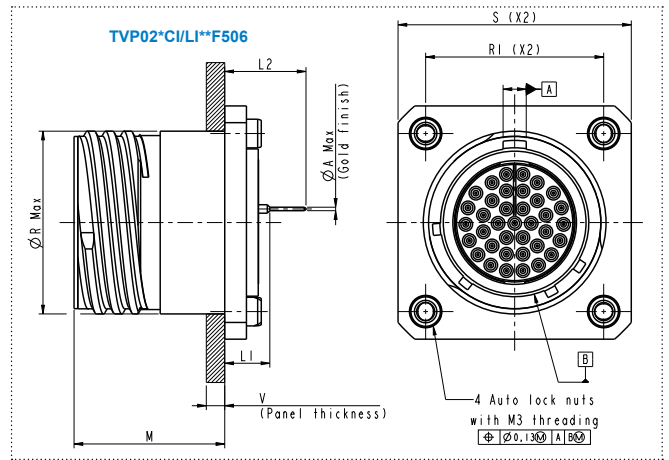
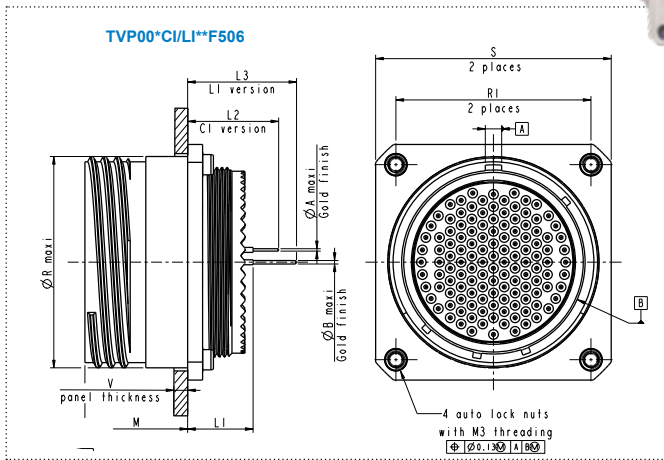

Contact type	Size		
	9 to 19	21 to 25	
P	L1 Min	11.55	12.31
	L1 Max	12.39	13.15
	L2 Min	16.45	17.21
	L2 Max	17.49	18.25
S	L1 Min	19.95	20.71
	L1 Max	20.99	21.75
	L2 Min	11.35	12.11
	L2 Max	12.19	12.95
S	L1 Min	16.25	17.01
	L1 Max	17.29	18.05
	L2 Min	19.75	20.51
	L2 Max	20.79	21.55

Size	M ⁰ _{-0.13}	ØR _{MAX}	S ±0.3	V _{MAX}	R1
9	20.83	15.88	26	5.8	18.26
11	20.83	19.05	28.4	5.8	20.62
13	20.83	22.23	30.8	5.8	23.01
15	20.83	25.4	32.3	5.8	24.61
17	20.83	30.16	34.6	5.8	26.97
19	20.83	31.75	37	5.8	29.36
21	20.07	34.73	39.7	5	31.75
23	20.07	38.1	42.9	5	34.93
25	20.07	41.28	46	5	38.1

Contact type	Size		
	9 to 19	21 to 25	
P	L1 Min	11.55	12.31
	L1 Max	12.39	13.15
	L2 Min	16.45	17.21
	L2 Max	17.49	18.25
S	L1 Min	19.95	20.71
	L1 Max	20.99	21.75
	L2 Min	11.35	12.11
	L2 Max	12.19	12.95
S	L1 Min	16.25	17.01
	L1 Max	17.29	18.05
	L2 Min	19.75	20.51
	L2 Max	20.79	21.55

All dimensions are given for information only and are in mm, except as otherwise specified | *in mm: 1mm=0.03937 inch

Due to technical modifications, all information provided is subject to change without prior notice
Designed by Amphenol Socapex

Series III TV-CTV
Series II JT
Series I LJT
Accessories & tools
Assembly instructions

MIL-DTL-38999 SERIES III EXTENDED RANGE - STAND-OFF RECEPTACLE



Double flange receptacles for PC tail applications

Description

Double flange receptacle for PC tail applications, avoiding stress on contact terminations while providing grounding continuity.

Main features

- Receptacle with Stand-off flange shell, for attachment to printed circuit boards.
- Prevent mechanical stress on the contact terminations.
- Provide grounding continuity between PCB and box.
- Increase reliability and resistance to shocks and vibrations.

OPTIONS

- Available in Aluminum (Olive drab Cadmium, Nickel, Black zinc nickel or Tin Zinc plating), Stainless Steel & Marine Bronze
- Tin plated or lead free terminations available.
- Square Flange - Wall mount (TVP*00) and Jam nut (TV*07) shells.

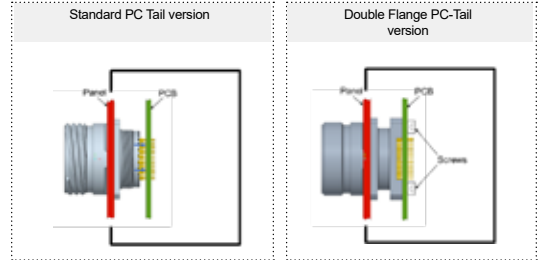

Amphenol Designations - TV Stand-off PC tails receptacles

1. Series	2. Shell type	3. Ground plane & Quadrax	4. Material and plating	5. PC Tail contacts	6. Contact arrangement	7. Contact gender	8. Keying	9. Deviation
TV	S07	-	F	CI	15-35	P	A	F459LFC

1. Series

TV Metal shells

2. Shell type

	Shell type	Associated materials and platings	Temperature
P00	Square flange - Wall mount receptacle	W, ZN, ZR, TZ	+175°C
PS00 *		F, K, S, B	+200°C *
07	Jam nut receptacle	W, ZN, ZR, TZ	+175°C
S07 *		F, K, S, B	+200°C *

* «S» Stand for 200°C compatibility. Omit for High-density inserts (SI), inserts with Quadrax contacts and differential Twinax contacts (SI) are +175°C maxi compatible.

3. Conductive inserts & inserts for Quadrax and differential Twinax contacts (optional)

Conductive inserts are available for Aluminum versions with Olive Drab Cadmium, Tin Zinc and Electroless Nickel. For any others materials and platings please consult us.

Blank	For standard inserts without ground plane and indexation key.
G	Ⓞ Ground Plane version - Conductive insert. Mandatory for 09-05*.
Q	Ⓞ Inserts designed with an indexation key to avoid contacts rotation in the cavities when using a keyed contact - Size 8 contacts only.
GQ	ⓄⓄ Ground plane version with insert designed with an indexation key.

* Please note that 09-05 insert is automatically conductive. Add the 'G' letter in all your references for this arrangement.

4. Material and platings

W		Olive Drab Cadmium
F		Electroless Nickel ✓
ZN	Aluminum	Black Zinc Nickel ✓
ZR		Black Zinc Nickel CrVI free (REACH) ✓
TZ		Tin Zinc ✓
K	Stainless steel	Passivated ✓
S		Electrodeposited Nickel ✓ (consult us for availability)
B	Marine Bronze* ✓	-

* Copper aluminum alloy

5. PC Tail contacts

CI	Standard length (5 mm)
LI	Long length (8.5 mm)
SI	Short length (size 22D contacts only) (4 mm)

6. Contact arrangement

Refer to page 18 for contact arrangements. First number represents the shell size and second number is the contact arrangement.

7. Contact gender

P	Pin (500 cycles)
S	Socket (500 cycles)

Connectors with PC Tail contacts are always delivered with contacts.

8. Keying

Blank (for normal)	A	B	C	D	E	U (Universal) Consult us
------------------------------	----------	----------	----------	----------	----------	---------------------------------------

9. Deviation

Shell style	PC Tail finish / Tinning				Shell type compatibility
	Tin lead	Silver tin ✓	Silver tin copper ✓	Gold ✓	
Stand-off	F459	F459LF	F459LFC	F459H	TVP*00 TV*07 Metal shell

For other deviations, please consult us.

All dimensions are given for information only and are in mm, except as otherwise specified | *in mm: 1mm=0.03937 inch

MIL-DTL-38999 SERIES III EXTENDED RANGE - STAND-OFF RECEPTACLE

Overall dimension Jam nut receptacle

TV*07*CI**F459**
TV*07*LI**F459**

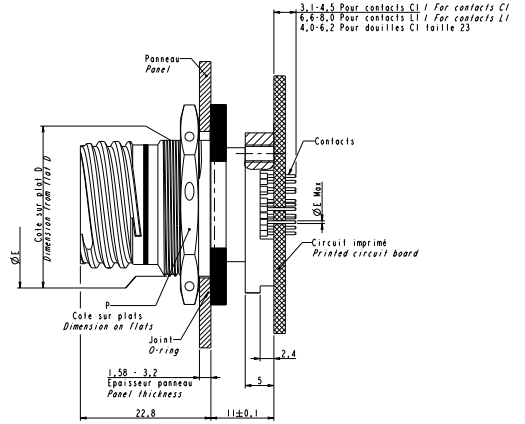
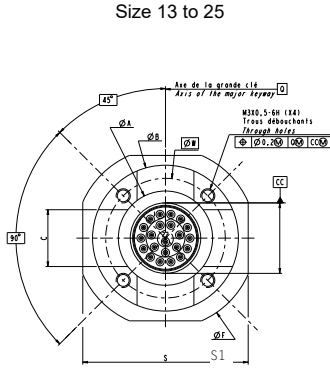
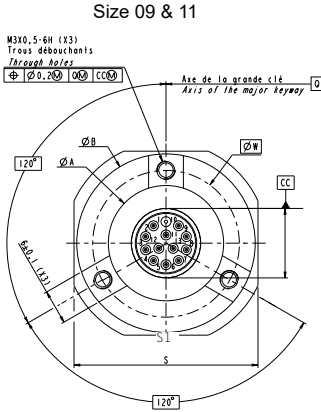

Square flange - Wall mount receptacle

TVP*00*CI**F459**
TVP*00*LI**F459**

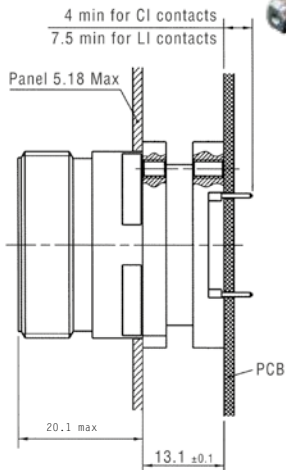
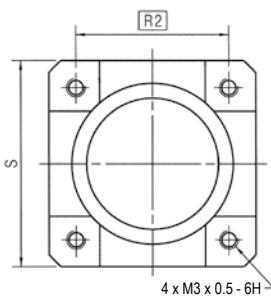

Size	S ±0.3	R2	S1 ±0.4	ØW
9	23.8	16.00	27.0	20.50
11	26.2	18.26	31.8	25.20
13	28.6	20.62	34.9	25.25
15	31.0	23.01	38.1	28.42
17	33.3	26.10	41.3	31.42
19	36.5	27.24	46.0	35.03
21	39.7	29.36	49.2	37.82
23	42.9	31.75	52.4	41.12
25	46.0	34.93	55.6	44.30

All dimensions are given for information only and are in mm, except as otherwise specified | *in mm: 1mm=0.03937 inch

Due to technical modifications, all information provided is subject to change without prior notice
Designed by Amphenol Socapex

Series III TV-CTV
Series II JT
Series I LJT
Accessories & tools
Assembly instructions

MIL-DTL-38999 SERIES III EXTENDED RANGE - REDUCED FLANGE RECEPTACLE

When small dimensions & lower weight are required

Description

Reduced flange receptacle derived from 38999 series III are dedicated to applications where size and weight are critical, offering a smaller footprint and higher contact density.

Main features

- Derived from MIL-DTL-38999 Series III connectors.
- For Jam nut receptacle (TV*07).
- Higher density on panel: 41% average footprint surface reduction.
- Lighter: 20% average lighter than standard 38999 stand off receptacle.
- Mates with standard MIL-DTL-38999 Series III plugs.
- Matches MIL-DTL-38999 Series III performances.
- Improved design of the o'ring groove allowing the o'ring to stay in place.

OPTIONS

- Crimp or PC tail contacts (standard or tinned)
- Stand-off (double flange) version for PC tail contacts
- Safety Castle nut versions for wire locking



Footprint savings

Average 41% footprint reduction:

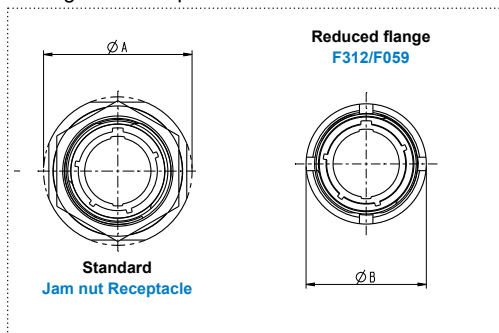

Size	38999 standard ØA _{MAX}	38999 Reduced flange (F312 & F059) ØB _{MAX}	% Ø reduction Standard vs Reduced Flange
9	30.5	22.1	47%
11	35.2	25.1	49%
13	38.4	28.1	46%
15	41.6	32.1	40%
17	44.8	36.1	35%
19	49.5	38.1	41%
21	52.7	41.1	39%
23	55.9	44.1	38%
25	59	48.1	34%

Panel hole dimensions

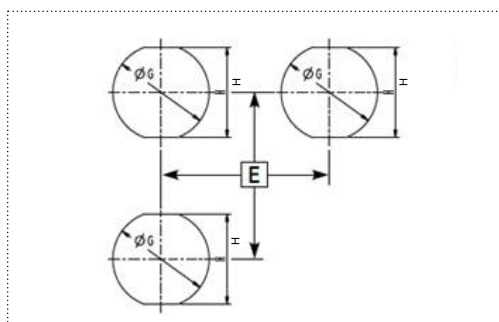

Size	E recommended	ØG ^{+0.1/0}	H ^{+0.1/0}
9	23.8	17	16
11	27.0	20	19.1
13	31.4	23	22.3
15	34.5	27	25.5
17	37.7	31	30.3
19	40.5	33	31.9
21	43.7	36	35.1
23	46.9	39	38.3
25	51.0	43	41.5

Tooling

Specific tool for castle nut tightening

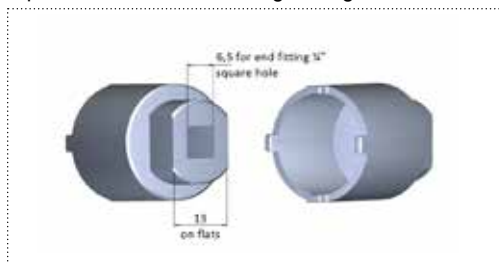

Size	Amphenol
9	809681
11	809682
13	809683
15	809684
17	809685
19	809686
21	809687
23	809688
25	809689

Apply same tightening torque and procedure as for standard jam nut receptacles.

All dimensions are given for information only and are in mm, except as otherwise specified | *in mm: 1mm=0.03937 inch

MIL-DTL-38999 SERIES III EXTENDED RANGE - HOW TO ORDER - REDUCED FLANGE

Amphenol Designations - Reduced flange receptacles - Crimp version

1.	2.	3.	4.	5.	6.	7.	8.	9.	10.
Series	Shell type	Crimp contacts	Ground plane and Quadrax	Material and platings	Contact arrangement	Contact gender	Keying	With or without contacts	Deviation
TV	07	R	Q	W	17-02	P	A	LC	F312

1. Series

TV	Metal shells (Aluminum, Stainless Steel, Marine Bronze)
-----------	---

2. Shell type

Shell type	Associated materials and platings	Temperature
07	W, ZN, ZR, TZ	+175°C
S07*	F, K, S, B	+200° C*

* «S» Stand for 200°C compatibility. Omit for High-density inserts ☺, inserts with Quadrax contacts and differential Twinax contacts ☹ are +175°C maxi compatible.

3. Crimp contacts

R	For W, F, Z, K, S and B materials & platings
Blank	For ZN and TZ platings

4. Conductive inserts & inserts for Quadrax and differential Twinax contacts (optional)

Conductive inserts are available for Aluminum versions with Olive Drab Cadmium, Tin Zinc and Electroless Nickel. For any others materials and platings please consult us.

Blank	For standard inserts without ground plane and indexation key.
G	☹ Ground Plane version - Conductive insert. Mandatory for 09-05*.
Q	☹ Inserts designed with an indexation key to avoid contacts rotation in the cavities when using a keyed contact - Size 8 contacts only.
GQ	☹☹ Ground plane version with insert designed with an indexation key.

* Please note that 09-05 insert is automatically conductive. Add the 'G' letter in all your references for this arrangement.

5. Material and platings

W		Olive Drab Cadmium
F		Electroless Nickel ✓
ZN	Aluminum	Black Zinc Nickel ✓
ZR		Black Zinc Nickel CrVI free ✓
TZ		Tin Zinc ✓
K	Stainless steel	Passivated ✓
S		Electrodeposited Nickel ✓ (consult us for availability)
B	Marine Bronze* ✓	-

* Copper aluminum alloy

6. Contact arrangement

Refer to page 18 for contact arrangements. First number represents the shell size and second number is the contact arrangement.

7. Contact gender

P	Pin (500 cycles)
S	Socket (500 cycles)

8. Keying

Blank (for normal)	A	B	C	D	E	U (Universal) Consult us
------------------------------	----------	----------	----------	----------	----------	---------------------------------------

Refer to page 28 for more information.

9. With or without contacts

Blank	Connector delivered with contacts
LC	Connector delivered without contacts

10. Deviation

Deviation	Description	Shell type compatibility
F312	Reduced flange receptacle with standard castle nut	TV*07
F311	Reduced flange receptacle with safety castle nut	

All dimensions are given for information only and are in mm, except as otherwise specified | *in mm: 1mm=0.03937 inch

Due to technical modifications, all information provided is subject to change without prior notice
Designed by Amphenol Socapex

Series III TV-CTV
Series II JT
Series I LJT
Accessories & tools
Assembly instructions

MIL-DTL-38999 SERIES III EXTENDED RANGE - HOW TO ORDER - REDUCED FLANGE

Amphenol Designations - TV Stand-off PC tails receptacles - PCB Receptacles



1.	2.	3.	4.	5.	6.	7.	8.	9.
Series	Shell type	Ground plane and Quadrax	Material and plating	PC Tail contacts	Contact arrangement	Contact gender	Keying	Deviation
TV	S07	-	F	CI	15-35	P	A	F059LF

1. Series

TV	Metal shells
----	--------------



2. Shell type

Shell type	Associated materials and platings	Temperature
07	W, ZN, TZ	+175°C
S07*	F, K, S, B	+200°C*

* «S» Stand for 200°C compatibility. Omit for High-density inserts , inserts with Quadrax contacts and differential Twinax contacts  are +175°C maxi compatible.

3. Conductive inserts & inserts for Quadrax and differential Twinax contacts (optional)

Conductive inserts are available for Aluminum versions with Olive Drab Cadmium, Tin Zinc and Electroless Nickel. For any others materials and platings please consult us.

Blank	For standard inserts without ground plane and indexation key.
G	 Ground Plane version - Conductive insert. Mandatory for 09-05*.
Q	 Inserts designed with an indexation key to avoid contacts rotation in the cavities when using a keyed contact - Size 8 contacts only.
GQ	 Ground plane version with insert designed with an indexation key.

* Please note that 09-05 insert is automatically conductive. Add the 'G' letter in all your references for this arrangement.

4. Material and platings

Material	Plating
W	Olive Drab Cadmium
F	Electroless Nickel ✓
ZN	Aluminum
ZR	Black Zinc Nickel ✓
TZ	Black Zinc Nickel CrVI free ✓
K	Tin Zinc ✓
S	Stainless steel
B	Passivated ✓
	Electrodeposited Nickel ✓
	Marine Bronze* ✓

* Copper aluminum alloy

5. PC Tail contacts

CI	Standard length (5 mm)
LI	Long length (8.5 mm)
SI	Short length (size 22D contacts only) (4 mm)

6. Contact arrangement

Refer to page 18 for contact arrangements
First number represents the shell size and second number is the contact arrangement

7. Contact gender

P	Pin (500 cycles)
S	Socket (500 cycles)

Connectors with PC Tail contacts are always delivered with contacts.

8. Keying

Blank (for normal)	A	B	C	D	E	U (Universal) Consult us
-----------------------	---	---	---	---	---	--------------------------------

Refer to page 28 for more information.

9. Deviation

Shell style	PC Tail finish / Tinning				Shell type compatibility
	Tin lead	Silver tin	Silver tin copper	Gold	
Reduced flange	F312	F312LF ✓	F312LFC ✓	F312H	TV*07 Metal shell
Reduced flange with safety castle nut	F311	F311LF ✓	F311LFC ✓	F311H	
Stand-off Reduced flange	F059	F059LF ✓	F059LFC ✓	F059H	
Stand-off Reduced flange with safety castle nut	F058	F058LF ✓	F058LFC ✓	F058H	

For other deviations, please consult us.

All dimensions are given for information only and are in mm, except as otherwise specified | *in mm: 1mm=0.03937 inch

MIL-DTL-38999 SERIES III EXTENDED RANGE - REDUCED FLANGE RECEPTACLE

Overall dimensions

Reduced flange Jam nut receptacle



With Standard
Castle nut
TV*07**F312

With Safety
Castle nut
TV*07**F311

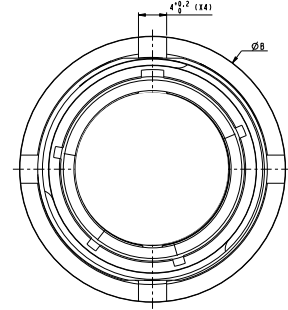
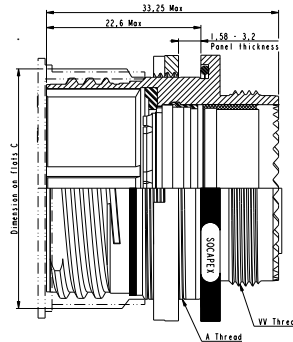
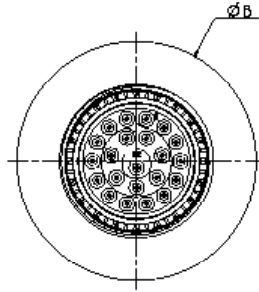

Size	ØB ±0.1	C ⁺⁰ / _{-0.13}	A thread	VV thread
9	22	15.93	M17x1-6g	M12x1-6g
11	25	19.03	M20x1-6g	M15x1-6g
13	28	22.23	M23x1-6g	M18x1-6g
15	32	25.43	M27x1-6g	M22x1-6g
17	36	30.23	M31x1-6g	M25x1-6g
19	28	31.83	M33x1-6g	M28x1-6g
21	41	35.03	M36x1-6g	M31x1-6g
23	44	38.23	M39x1-6g	M34x1-6g
25	48	41.43	M43x1-6g	M37x1-6g

Reduced flange Stand-off Jam nut receptacle



With Standard
Castle nut
TV*07**F059

With Safety
Castle nut
TV*07**F058

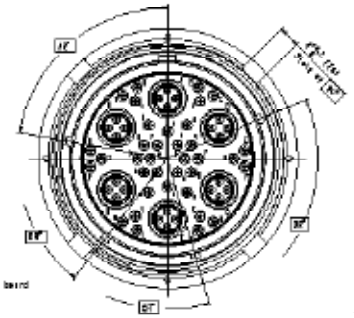
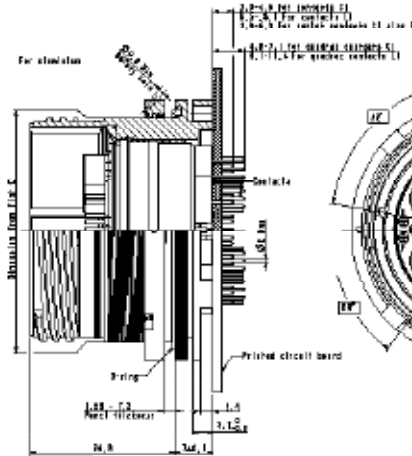
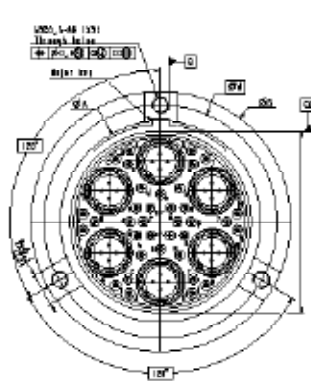

Size	ØA ±0.15	ØB ±0.1	ØW	C ⁺⁰ / _{-0.13}
9	12	22	17	15.93
11	15	25	20	19.03
13	18	28	23	22.23
15	21	32	26.5	25.43
17	26	36	31	30.23
19	27	38	33	31.83
21	30	41	36	35.03
23	33	44	39	38.23
25	37	48	43	41.43

All dimensions are given for information only and are in mm, except as otherwise specified | *in mm: 1mm=0.03937 inch

Series III TV-CTV
Series II JT
Series I LJT
Accessories & tools
Assembly instructions

MIL-DTL-38999 SERIES III EXTENDED RANGE - ENHANCED SEALING

Helium leakage limited to 1.10⁻⁶ cm³ per second

Description

TV**ETC, TV**ETCI, TV**ETLI receptacles with enhanced sealing are derived from the standard MIL-DTL-38999 Series III receptacles. These receptacles help avoiding leakage and offer a protection against external contamination.

Main features

- Receptacles with enhanced sealing – intermeatable with MIL-DTL-38999 Series III plugs
- Available on standard signals arrangements with Solder Cup or PC-Tails pin contacts
- Operating Temperature range: -55 / +125°C.
- Initial sealing performance: Helium leakage < 1.10⁻⁶ cm³/s under 1 bar of differential pressure.
- Designed for unpressurized area.
- Avoid any stress on contacts before, during and after wave or iron soldering process.
- With Stand-off shells, shells must be threaded onto the PC Board before any soldering.
- We advise to use HFE cleaning product and strongly not recommend any Vigon based one.

CONTACTS TERMINATIONS	How to order
Solder Cup contacts	ETC
PC Tail - Standard Length	ETCI
PC Tail - Long Length	ETLI



Amphenol Designations - TV & CTV Enhanced Sealing Receptacles

Series	Shell type	Material and platings	Enhanced sealing	Contact type	Contact arrangement	Contact gender	Keying	Deviation
TV	07	W	ET	C	15-35	P	A	F312

1. Shell type (receptacles only)

Shell type	Associated materials and platings	Temperature max
07	W, ZN, ZR, TZ	+125°C
S07	Jam nut receptacle F, K, S, B	
P00	Square flange receptacle F, K, S, B	
PS00	F, K, S, B	

For ETCI connectors, all service classes are rated -55°C to +125°C max, regardless of the material or finish ordered

6. Contact gender

P	Pin contacts (500 cycles)
S	Socket contacts (500 cycles)

Enhanced sealing receptacles are always delivered with contacts

7. Keying

Blank (for normal)	A	B	C	D	E
--------------------	---	---	---	---	---

Refer to page 28 for more information

2. Material and platings

Shell material	Shell finish
W	Olive Drab Cadmium
F	Electroless Nickel ✓
ZN	Aluminum Black Zinc Nickel ✓
ZR	Black Zinc Nickel CrVI free ✓
TZ	Tin Zinc ✓
K	Stainless steel Passivated ✓
B	Marine bronze* ✓

*Copper aluminum alloy

8. Deviation

Shell style	PC Tail finish / Tinning <i>(for Solder cup version, please use tin lead code)</i>				Shell type compatibility
	Tin lead	Silver tin ✓	Silver tin copper ✓	Gold ✓	
Standard (Tinned PC-Tails)	F404	F404LF	F404LFC	Blank	PC-Tail only (TV and CTV Series)
Equipped with clinch nuts	F506G	F506LF	F506LFC	F506	TVP*00 TVP*02 Aluminum shell
Stand-off	F459	F459LF	F459LFC	F459H	TVP*00 TV*07 Metal shell
Reduced flange	F312	F312LF	F312LFC	F312H	
Reduced flange with safety castle nut	F311	F311LF	F311LFC	F311H	TV*07 Metal shell
Stand-off Reduced flange	F059	F059LF	F059LFC	F059H	
Stand-off Reduced flange with safety castle nut	F058	F058LF	F058LFC	F058H	

For other deviations, please consult us.

3. Enhanced sealing

ET	Mandatory
----	-----------

4. Contact type - Non-removable contacts only

CI	PC Tail contacts - Standard length
LI	PC Tail contacts - Long length
C	Solder cup contacts

5. Contact arrangement

Refer to page 18 for contact arrangements
First number represents the shell size and second number is the contact arrangement

All dimensions are given for information only and are in mm, except as otherwise specified | *in mm: 1mm=0.03937 inch

Due to technical modifications, all information provided is subject to change without prior notice
Designed by Amphenol Socapex

Series III TV-CTV
Series II JT
Series I LJT
Accessories & tools
Assembly instructions

MIL-DTL-38999 SERIES III EXTENDED RANGE - ENHANCED SEALING RECEPTACLES

Overall dimensions Square flange - Wall mount receptacle

- TVP*00*ETC* Solder Cup contacts
- TVP*00*ETCI* PC Tail contacts
- TVP*00*ETLI* PC Tail contacts

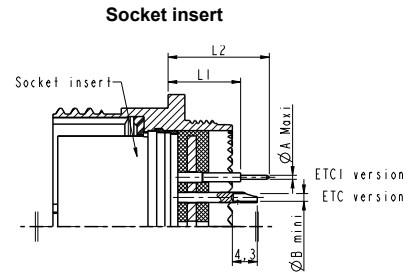
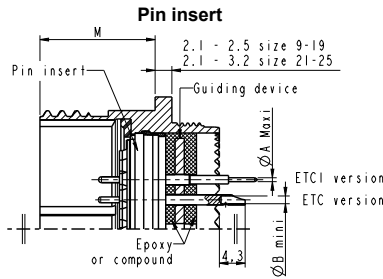

		Connector size		Contact			
		9-19	21-25	size 22D	size 20	size 16	size 12
Socket contact	L1	11.35-12.19	12.11-12.95	0.5	0.7	1.15	1.7
	L2	16.25-17.29	17.01-18.08	0.6	0.8	1.25	1.8
Pin contact	L1	11.55-12.39	12.31-13.15	0.87	1.34	1.94	2.91
	L2	16.45-17.49	17.21-18.25				
				PCB	ØA gold plating		
				Solder cup	ØA lead tin plating		
					ØB		

Jam nut receptacle

- TV*07*ETC* Solder Cup contacts
- TV*07*ETCI* PC Tail contacts
- TV*07*ETLI* PC Tail contacts

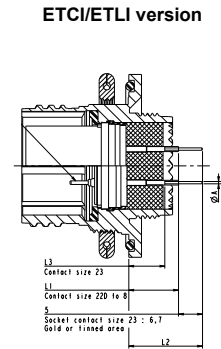
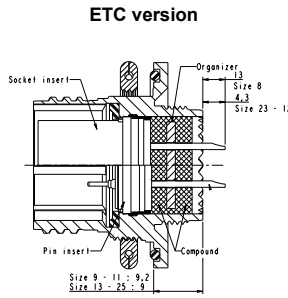

		Solder cup						PCB contact						Contact		Connector size			
		Size	23	22D	20	16	12	8	Size	23	22D	20	16	12	8	Socket 22D-8	Socket 23	9-11	13-25
Wire AWG MAX		22	22	20	16	12	8		Without F404-F376	0.5	0.5	0.7	1.15	1.7	-	L1	9.9-10.9	9.7-10.7	
Section mm ²		0.38	0.38	0.6	1.34	1.94	10			0.6	0.6	0.8	1.25	1.8	3.8	L2	14.8-16	14.6-15.8	
																L3	6.6-8.5	6.4-8.3	
																L1	13.2-15.3	13-15.1	
																L2	10.1-11.1	9.9-10.9	
																L2	15-16.2	14.8-16	
																L3	10.1-11.4	10-11.3	
																L2	15-16.5	14.9-16.4	

All dimensions are given for information only and are in mm, except as otherwise specified | *in mm: 1mm=0.03937 inch

Due to technical modifications, all information provided is subject to change without prior notice
Designed by Amphenol Socapex

MIL-DTL-38999 SERIES III EXTENDED RANGE - THRU-BULKHEAD

Receptacles using 38999 III inserts dedicated to thru-bulkhead applications

Description

TVB series offers thru-bulkhead receptacles to be used for the feed through of circuits on bulkheads or panels. These feedthrough receptacles are fully compatible with standard plugs.



Main features

- Intermateable with MIL-DTL-38999 Series III plugs.
- 8 shell sizes (from size 11 to 25).
- Interfacial seal on male side.
- Materials: Aluminum or Marine Bronze.
- Platings (Aluminum only): Olive drab cadmium, Nickel, Black zinc nickel
- Polarization possibility.

Amphenol Designations - Thru Bulkhead Receptacles

Series	1. Shell type	2. Material and platings	3. Contact arrangement	4. Contact gender	5. Keying	6. Deviation
TVB	-	W	15-35	PS	N	F467

1. Shell type (Receptacles only)

Blank	Square flange receptacle
07	Jam nut receptacle
LP07	Low profile Jam nut receptacle

2. Material and platings

Shell material	Shell finish
W	Olive Drab Cadmium
F	Electroless Nickel ✓
ZN	Aluminum Black Zinc Nickel ✓
ZR	Black Zinc Nickel CrVI free ✓
TZ	Tin Zinc ✓
B	Marine Bronze* ✓

*Copper aluminum alloy

✓ : RoHS compliant

3. Contact arrangement

Refer to page 18 for contact arrangements.
First number represents the shell size and second number is the contact arrangement.

4. Contact gender

PS	Pin & Socket
----	--------------

5. Keying

N (for normal)	A	B	C	D	E
----------------	---	---	---	---	---

6. Deviation

F467	Drilled and tapped mounting holes Mandatory for square flange receptacles
------	--

For other deviations, please consult us.

All dimensions are given for information only and are in mm, except as otherwise specified | *in mm: 1mm=0.03937 inch

Due to technical modifications, all information provided is subject to change without prior notice
Designed by Amphenol Socapex

MIL-DTL-38999 SERIES III EXTENDED RANGE - THRU-BULKHEAD

Overall dimensions Square flange receptacle



TVBW**F467
TVBF**F467
TVBZN**F467
TVBTZ**F467
TVBB**F467
TVBZR**F467

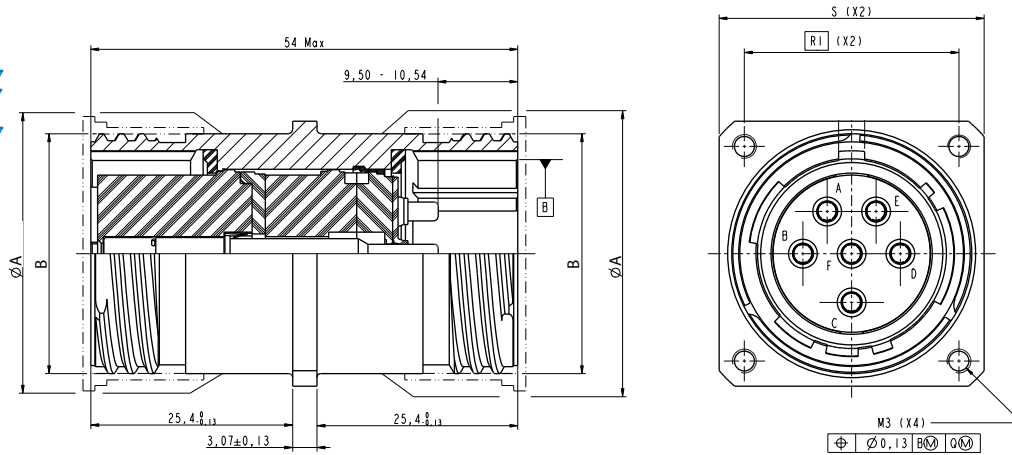

Size	B thread class 2A 0.1P-0.3L-TS (inch)	ØA _{MAX}	RI	S ± 0.3
11	.7500	19.05	20.62	26.2
13	.8750	22.23	23.01	28.6
15	1.0000	25.40	24.61	31.0
17	1.1875	30.16	26.97	33.3
19	1.2500	31.75	29.36	36.5
21	1.3750	34.73	31.75	39.7
23	1.5000	38.10	34.93	42.9
25	1.6250	41.28	38.10	46.0

Jam nut receptacle



TVB07W**
TVB07F**
TVB07ZN**
TVB07TZ**
TVB07B**
TVB07ZR**

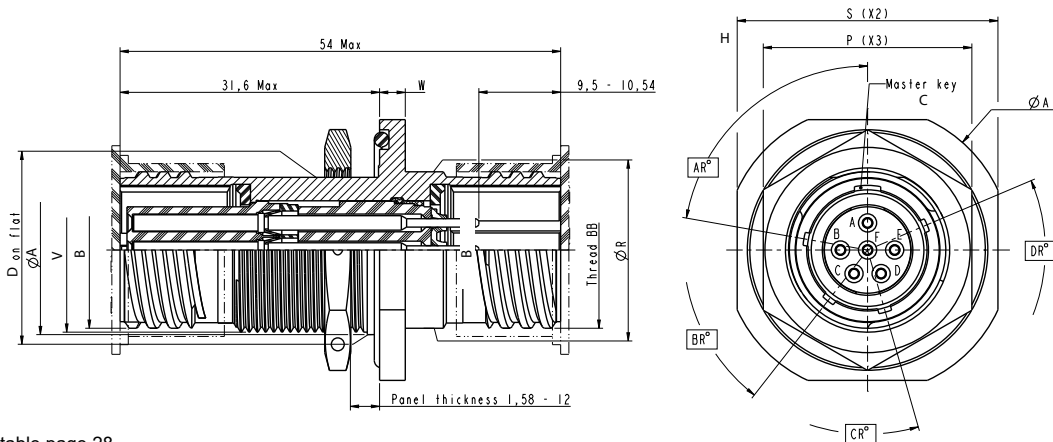

Keyway position according to table page 28.

Size	B thread class 2A 0.1P-0.3L-TS (inch)	V thread-metric	ØD ^{+0.1 -0.15}	ØA ^{+0.1 -0.2}	W _{MAX}	ØR _{MAX}	ØC _{MAX}	S ± 0.4	H ± 0.4
11	.7500	M20x1-6g	19.07	20.6	3.5	19.05	35.2	31.8	25.4
13	.8750	M25x1-6g	23.82	25.4	3.5	22.23	38.4	34.9	30.2
15	1.0000	M28x1-6g	26.97	28.5	3.5	25.40	41.6	38.1	33.3
17	1.1875	M32x1-6g	30.15	32.0	3.5	30.16	44.8	41.3	36.5
19	1.2500	M35x1-6g	33.32	35.0	3.5	31.75	49.5	46.0	39.7
21	1.3750	M38x1-6g	36.5	38.0	3.3	34.73	52.7	49.2	42.9
23	1.5000	M41x1-6g	39.67	41.2	3.3	38.10	55.9	52.4	46.0
25	1.6250	M44x1-6g	42.85	44.4	3.3	41.28	59	55.6	50.8

All dimensions are given for information only and are in mm, except as otherwise specified | *in mm: 1mm=0.03937 inch

Due to technical modifications, all information provided is subject to change without prior notice
Designed by Amphenol Socapex

Series III TV-CTV
Series II JT
Series I LJT
Accessories & tools
Assembly instructions

MIL-DTL-38999 SERIES III EXTENDED RANGE - THRU-BULKHEAD

Jam nut receptacle - Low profile version



- TVBLP07W**
- TVBLP07F**
- TVBLP07ZN**
- TVBLP07TZ**
- TVBLP07B**
- TVBLP07ZR**

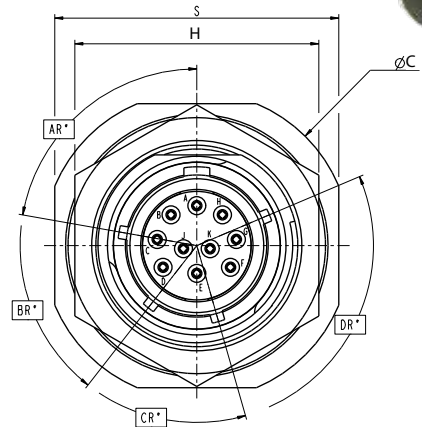
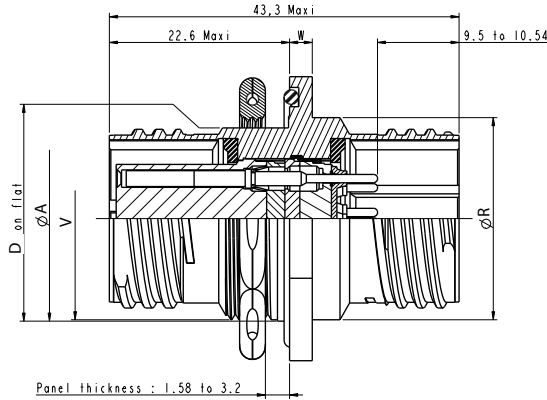

Keyway position according to table page 28.

Size	V thread-metric	ØD	ØA	W _{MAX}	ØR _{MAX}	ØC _{MAX}	S ± 0.4	H ± 0.4
9	M17x1-6g	16.53	17.4	2.7	17.2	30.5	27.0	22.26
11	M20x1-6g	19.07	20.6	2.7	20.2	32.2	31.8	25.4
13	M25x1-6g	23.82	25.4	2.7	25.2	38.4	34.9	30.2
15	M28x1-6g	26.97	28.5	2.7	28.2	41.6	38.1	33.3
17	M32x1-6g	30.15	32.0	2.7	32.2	44.8	41.3	36.5
19	M35x1-6g	33.32	35.0	3.6	35.2	49.5	46.0	39.7
21	M38x1-6g	36.5	38.0	3.6	38.2	52.7	49.2	42.9
23	M41x1-6g	39.67	41.2	3.6	41.2	55.9	52.4	46.0
25	M44x1-6g	42.85	44.4	3.6	44.2	59	55.6	50.8

All dimensions are given for information only and are in mm, except as otherwise specified | *in mm: 1mm=0.03937 inch

Due to technical modifications, all information provided is subject to change without prior notice
Designed by Amphenol Socapex









MIL-DTL-38999 SERIES III DERIVED RANGE



Table of contents

DERIVED RANGE	97
387TV - Size 7 shell	98
PowerSafe - VG96944 - Power with User safety	112
RNJ LP - Rack and panel	126
SC39 - Quick disconnection	134
TVμCOM - 10GB+	142
TVOP	148
StartOP	148

THE DERIVED RANGE SERVES VARIOUS MARKETS, INCLUDING:

- 
 Commercial Avionics & Airframe
- 
 Military Avionics & Airframe
- 
 Military vehicles
- 
 C4ISR
- 
 Missiles
- 
 Navy
- 
 Industrial

All dimensions are given for information only and are in mm, except as otherwise specified | *in mm: 1mm=0.03937 inch

Due to technical modifications, all information provided is subject to change without prior notice
 Designed by Amphenol Socapex

MIL-DTL-38999 SERIES III DERIVED RANGE - 387TV - SIZE 7 SHELL



The smallest connector derived from MIL-DTL-38999 series III

Description

Size 7 connectors derived from MIL-DTL-38999 Series III dedicated to application where miniature size and low weight are critical. This range can accommodate a size 8 High-Speed contacts (Coax, Twinax, Quadrax, 1Gb & 10 Gb Octomax), any 38999 size 9 contacts arrangement and Fiber Optics.

Main features

DERIVED FROM MIL-DTL-38999 SERIES III CONNECTORS.

MATERIALS AND PLATINGS:

- Aluminum: Olive drab cadmium, Nickel, Black zinc nickel

AVAILABLE SHELLS:

- Plugs with integrated backshells.
- Receptacles :
 - Jam-nut receptacles : Standard, Reduced flange or Stand-off
 - Reduced flange
 - Oval flange receptacles

CRIMP VERSIONS SHELLS ARE ALWAYS DESIGNED WITH AN INTEGRATED BACKSHELL.

MANY POSSIBILITIES :

- 07-05 Ⓞ : Grounded Size 8 Cavity (Coax, Twinax, Quadrax and Octomax)
- All size 9 38999 inserts including High density HD (Contacts size 23 to 12)
- Fiber optics (387TV with MT ferrule, 387TV OP with double Luxbeam Q8D also available)

CONTACTS - COPPER VERSIONS:

- Crimp or PC tail contacts - several tinning available.
- For Grounded High-Speed version (07-05 Ⓞ), plugs are always delivered with sockets contacts and receptacles with pin contacts.

IP68: 48 hours under 2 meters of water for Jam nut receptacle and mated plug when using a heatshrink boot and adhesive between the plug and the cable.

How to order : Amphenol Designations - 387TV Crimp Connectors

Series	Shell type	Crimp contacts	Contact type	Material and platings	Contact arrangement	Contact gender	Keying	With or without contact	Deviation
387TV	07	R	GQ	W	07-05	P	-	-	F312

1. Shell type

Shell type	Associated materials and plating	Temperature
06 S06*	Plugs with integrated backshell W, ZN, ZR, TZ F, K, S, B	+175°C +200°C *
07 S07*	Jam nut receptacle with integrated backshell W, ZN, ZR, TZ F, K, S, B	+175°C +200°C *
03 S03*	Oval flange receptacle with integrated backshell W, ZN, ZR, TZ F, K, S, B	+175°C +200°C *

* «S» Stand for 200°C compatibility. Omit for High-density inserts Ⓞ, inserts with Quadrax contacts and differential Twinax contacts Ⓞ are +175°C maxi compatible.

2. Crimp contacts

- R** For W, F, K, S and B platings
- Blank** For ZN & TZ platings

3. Contact type

- GC** Coax 50Ω - 07-05 Ⓞ only
- GM** Coax 75Ω for RG179 cable type - 07-05 Ⓞ only
- GV** Coax 75Ω for PIC V75268 cable type - 07-05 Ⓞ only
- GT** Twinax - 07-05 Ⓞ only
- GQ** Quadrax 100Ω - 07-05 Ⓞ only
- GO** Octomax - 07-05 Ⓞ only
- G** Ground Plane without contact - Mandatory for 07-05 Ⓞ
- M** Coax 75Ω #12 - 07-12 contact arrangement only
- Blank** Standard signal Contact (07-09, 07-12, 07-35, 07-98)

4. Material and platings

Shell material	Shell finish
W	Olive drab cadmium
F	Nickel ✓
ZN	Black zinc nickel ✓
ZR	Black Zinc Nickel CRVI Free ✓

* Copper aluminum alloy
For other materials, please consult us

5. Contact arrangement

Layout	Contact size	Total contacts
07-05 Ⓞ	8	1
07-09 HD	23	9
07-12	12	1
07-35	22D	6
07-98	20	3

6. Contact gender

- P** Pin (500 cycles) - 07-05 Ⓞ Mandatory for receptacles
- S** Socket (500 cycles) - 07-05 Ⓞ Mandatory for plugs

7. Keying

Blank (for normal)	A	B	C	D
--------------------	---	---	---	---

8. With or without contact

- Blank** Delivered with contacts
- LC** Delivered without contacts

9. Deviation

Deviation	Description	Shell type compatibility
F312	Reduced flange receptacle	07 / S07
F506	Oval flange equipped with clinch nuts	03 / S03*

For other deviations, please consult us
*Oval flange receptacle equipped with clinch nuts are not available in Black Zinc Nickel, Bronze, or Stainless Steel.

All dimensions are given for information only and are in mm, except as otherwise specified | *in mm: 1mm=0.03937 inch

Due to technical modifications, all information provided is subject to change without prior notice
Designed by Amphenol Socapex

Series III TV-CTV
Series II JT
Series I LJT
Accessories & tools
Assembly instructions

MIL-DTL-38999 SERIES III DERIVED RANGE - HOW TO ORDER 387TV PC-TAIL

Amphenol Designations - 387TV PCB Receptacles

	1.	2.	3.	4.	5.	6.	7.	8.
Series	Shell type	Contact type	Material and platings	PC Tail contacts	Contact arrangement	Contact gender	Keying	Deviation
387TV	07	M	W	CI	07-12	P	-	F059

1. Shell type (receptacles only)

Shell type	Associated materials and plating	Temperature
07 S07* Jam nut receptacles	W, ZN, ZR, TZ F, K, S, B	+175°C +200°C*
03 S03* Oval flange receptacles	W, ZN, ZR, TZ F, K, S, B	+175°C +200°C*

* For connectors with Quadrax and differential Twinax contacts please omit the 'S' corresponding to 200°C compatibility. Quadrax contacts and differential Twinax contacts are +175°C maxi compatible.

2. Contact type

GC	Coax 50Ω - 07-05 G only
GM	Coax 75Ω - 07-05 G only
GT	Twinax - 07-05 G only
GQ	Quadrax 100Ω - 07-05 G only
GO	Octomax - 07-05 G only
M	Coax 75Ω #12 - 07-12 contact arrangement only
Blank	Standard signal Contact (07-09, 07-12, 07-35, 07-98)

3. Material and platings

Shell material	Shell finish
W	Olive drab cadmium
F	Nickel ✓
ZN	Aluminum
ZR	Black zinc nickel ✓
	Black Zinc Nickel CRVI Free ✓





* Copper aluminum alloy
For other materials, please consult us

4. PC Tail contacts

CI	Standard length
-----------	-----------------

For other length, please consult us

5. Contact arrangement

Layout	Contact size	Total contacts
 07-05 G	8	1
 07-09 HD	23	9
 07-12	12	1
 07-35	22D	6
 07-98	20	3

6. Contact gender

P	Pin (500 cycles) - 07-05 G Mandatory for receptacles
S	Socket (500 cycles)

7. Keying

Blank (for normal)	A	B	C	D
------------------------------	----------	----------	----------	----------

8. Deviation

Shell style	PC Tail finish / Tinning				Shell type compatibility
	Tin lead	Silver tin ✓	Silver tin copper ✓	Gold ✓	
Standard	F404	F404LF	F404LFC	Blank	All
Stand-off Reduced flange	F059	F059LF	F059LFC	F059H	07 / S07
Oval flange with clinch nuts	F506G	F506LF	F506LFC	F506	03 / S03*

For other deviations, please consult us

*Oval flange receptacle equipped with clinch nuts are not available in Black Zinc Nickel, Bronze, or Stainless Steel.

All dimensions are given for information only and are in mm, except as otherwise specified | *in mm: 1mm=0.03937 inch

Due to technical modifications, all information provided is subject to change without prior notice
Designed by Amphenol Socapex

MIL-DTL-38999 SERIES III DERIVED RANGE - 387TV - SIZE 7 SHELL

Contacts arrangements

Arrangement (TV-CTV)	07-05 ^G	07-09 ^{HD}	07-12	07-35	07-98
Total contact	1	9	1	6	3
Contact size	8	23	12	22D	20

For more information on contact arrangements, service ratings and contacts, see table page 18.

Material and platings

Same performances as MIL-DTL-38999 Series III connector in terms of Temperature, Salt Spray resistance.

	Shell material	Shell finish	Operating Temperature (C°)		Salt spray exposure per EIA 364.26 (hours)
			min	max	
W	Aluminium	Olive drab cadmium	-65	+175	500
F		Nickel ✓	-65	+200 ^{HD}	48
ZN, ZR		Black zinc nickel ✓	-65	+175	500

For other Materials and platings, please consult us.

Differences with standard TV - MIL-DTL-38999 series III

Thread coupling	Double start instead of triple start
Shell style for crimp versions (plug and receptacle)	Always with integrated backshell
Lightning strike	Composite 38999 level (MIL-DTL-38999 class M)
EMI performances	82dB min at 100MHz (vs 90dB min for 38999 standard) 65dB min at 1000MHz (vs 85dB for 38999 standard)
Shocks & vibrations	<p>Shock Half sine wave of 300 G magnitude during 3ms per EIA-364-27</p> <p>Vibration</p> <p>Sine vibrations:</p> <ul style="list-style-type: none"> - 60G between 140Hz and 1500Hz - Temperatures (x3 axes) : @ Room temperature for 4H @ -55°C for 4H @ 175°C for 4H <p>Random vibrations: per EIA-364-28:</p> <ul style="list-style-type: none"> - 37.83 grms at 175°C (Aluminum with Olive drab cadmium and Black zinc nickel), 50 to 1500 Hz - 50.09 grms at ambient air, 10 to 1500 Hz

- ^G 387TV is only available in Grounded version with the 07-05 layout
- ^{HD} High density 38999, Quadrax and differential Twinax arrangements not rated over 175°C
- ✓ RoHS compliant

All dimensions are given for information only and are in mm, except as otherwise specified | *in mm: 1mm=0.03937 inch

Due to technical modifications, all information provided is subject to change without prior notice
Designed by Amphenol Socapex

Series III TV-CTV
Series II JT
Series I LJT
Accessories & tools
Assembly instructions

MIL-DTL-38999 SERIES III DERIVED RANGE - 387TV - SIZE 7 SHELL

Jam nut receptacle



Crimp version

387TV*07**07**

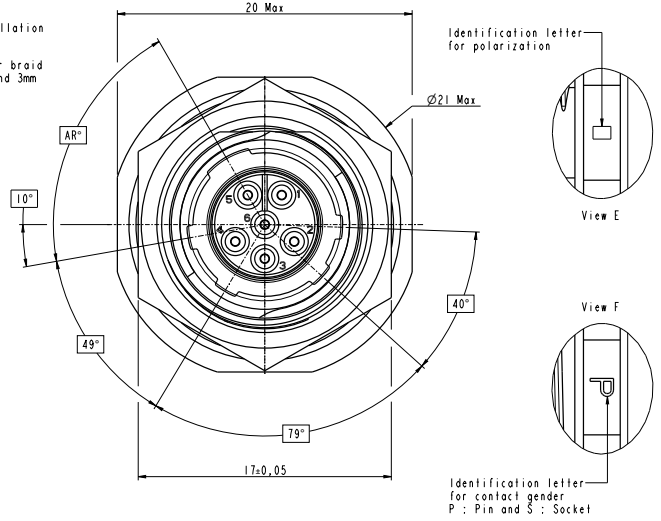
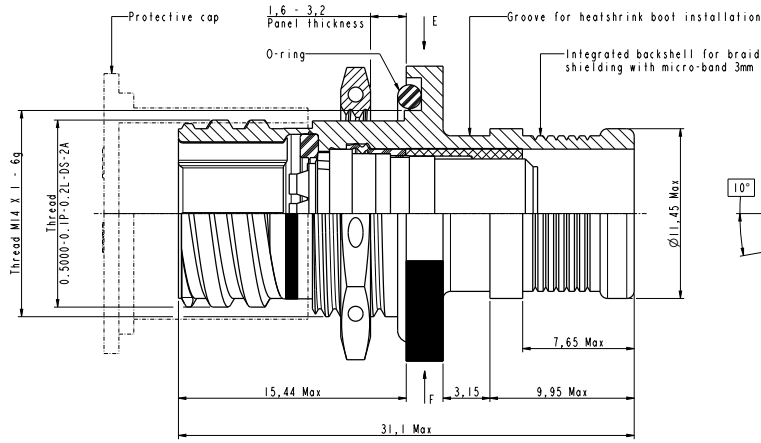

PC-Tail version

387TV*07*CI*07**

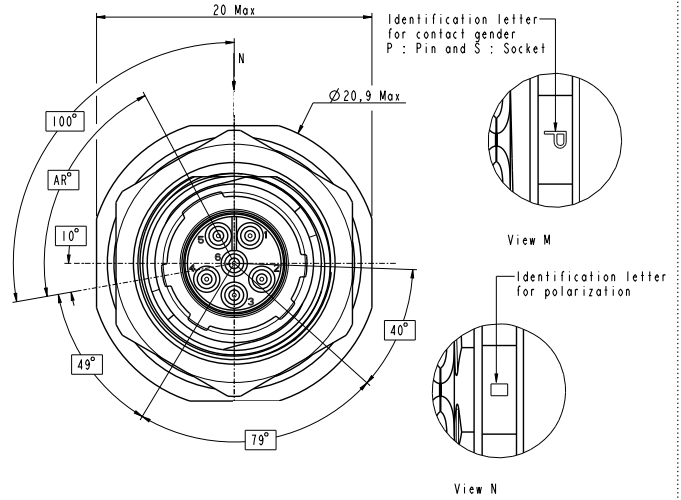
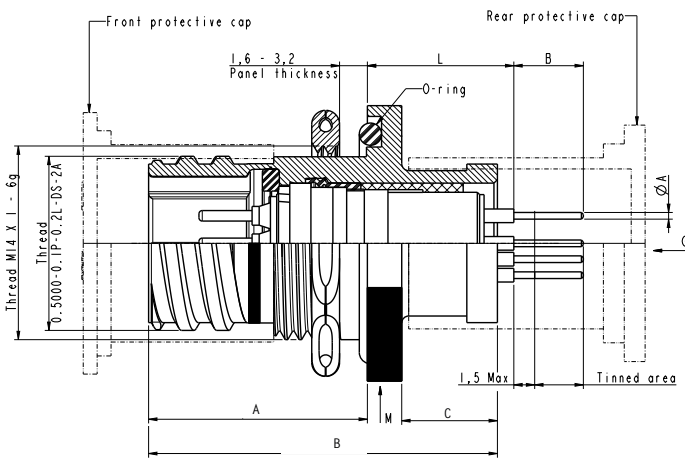

Arrangement	L Max	L Min	B Max	B Min	Ø A	
7-09	11,85	10,14	5,1	4,9	0,6	
7-12	Standard	11,68	10,10	5,1	4,9	1,8
	Coax 75Ω	11,18	9,60	5,9	5,1	View G
7-35	11,18	10,14	5,1	4,9	0,6	
7-98	11,18	10,14	5,1	4,9	0,8	

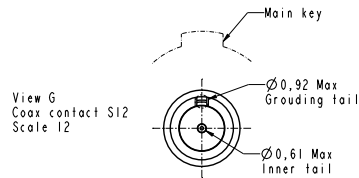

Keyway position according to table page 108.

Gender	A MAX	B MAX	C MAX
Pin - 387TV*07**CI**P	15.86	25.31	6.98
Socket - 387TV*07**CI**S	21.25	30.84	7.12

All dimensions are given for information only and are in mm, except as otherwise specified | *in mm: 1mm=0.03937 inch

Due to technical modifications, all information provided is subject to change without prior notice
Designed by Amphenol Socapex

Series III TV-CTV
Series II JT
Series I LJT
Accessories & tools
Assembly instructions

MIL-DTL-38999 SERIES III DERIVED RANGE - 387TV - SIZE 7 SHELL

Jam nut Reduced flange receptacle



Crimp version - Reduced Flange

387TV*07**07**F312

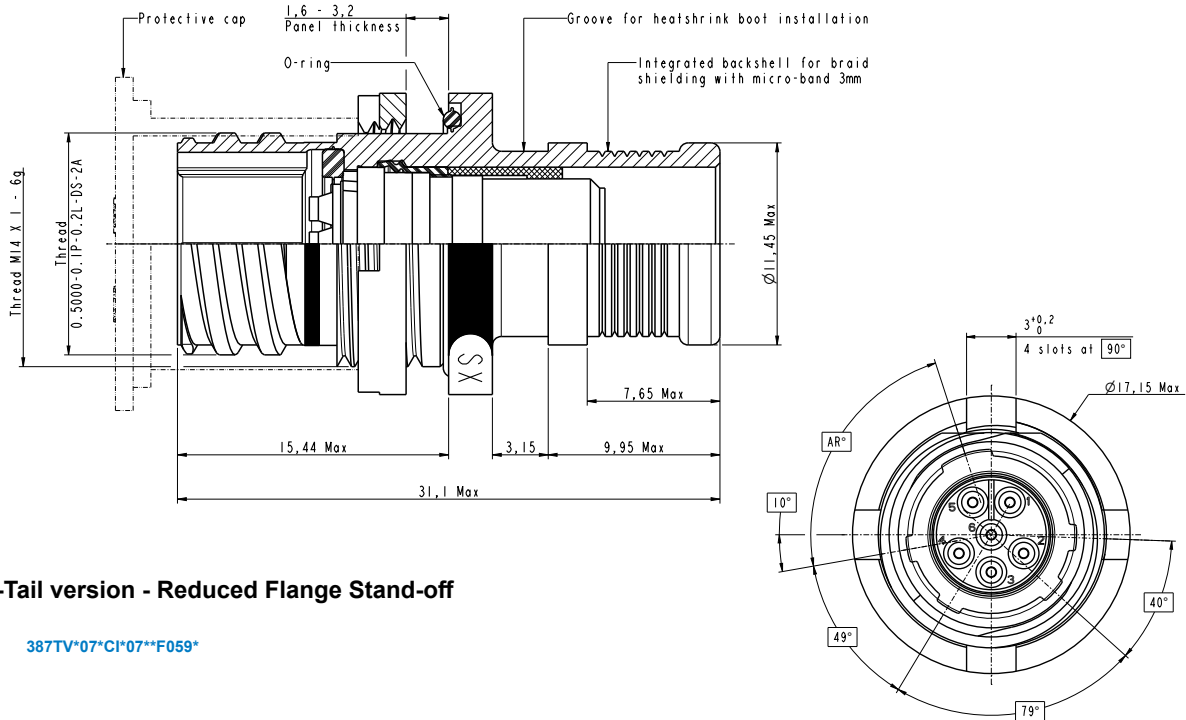

PC-Tail version - Reduced Flange Stand-off

387TV*07*CI*07**F059*

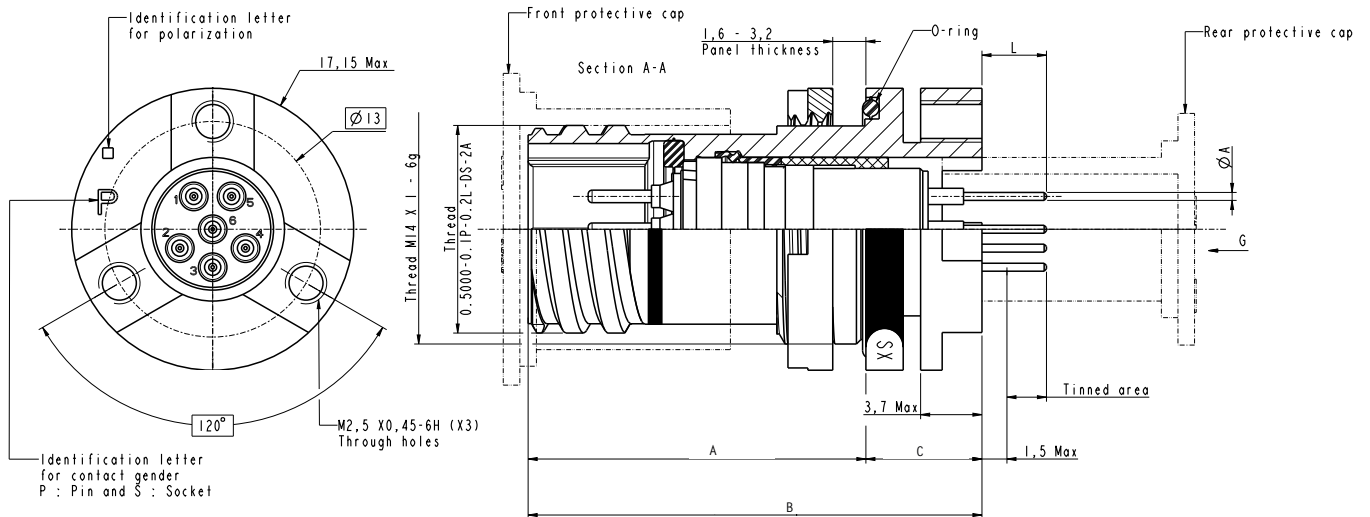

Arrangement	LI Max	LI Min	Ø A
7-09	5,38	3,25	0,6
7-12	Standard	5,21	3,21
	Coax 75Ω	5,31	3,11
7-35	4,71	3,25	0,6
7-98	4,71	3,25	0,8

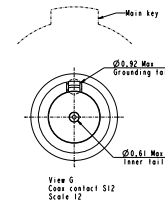

Keyway position according to table page 108.

Gender	A MAX	B MAX	C MAX
Pin - 387TV*07**CI**PF059*	20.50	27.37	7.1
Socket - 387TV*07**CI**SF059*	26.13	33.00	

All dimensions are given for information only and are in mm, except as otherwise specified | *in mm: 1mm=0.03937 inch

Due to technical modifications, all information provided is subject to change without prior notice
Designed by Amphenol Socapex

MIL-DTL-38999 SERIES III DERIVED RANGE - 387TV - SIZE 7 SHELL

Plug with Integrated Backshell



387TV*06**07**

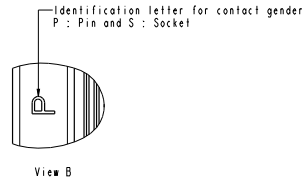
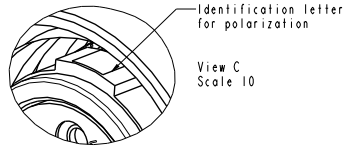
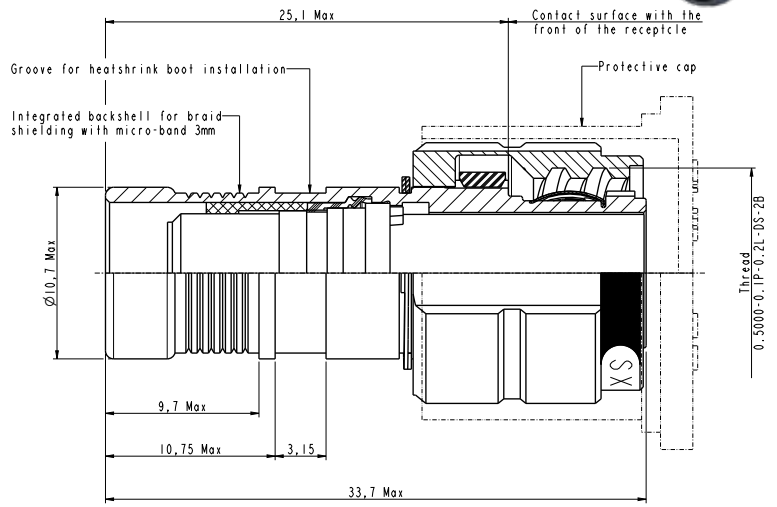
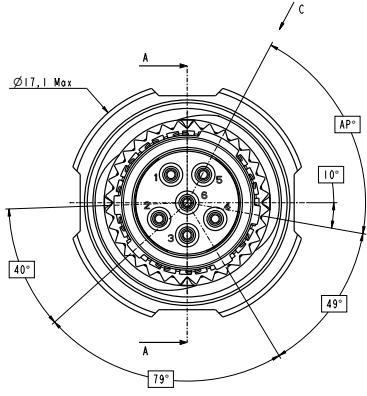

Keyway position according to table page 108.

All dimensions are given for information only and are in mm, except as otherwise specified | *in mm: 1mm=0.03937 inch

Series III TV-CTV
Series II JT
Series I LJT
Accessories & tools
Assembly instructions

MIL-DTL-38999 SERIES III DERIVED RANGE - 387TV - SIZE 7 SHELL

387TV 07-05 - The smallest shell around a Size 8 contact

Contacts possibilities

As a reminder, in 07-05 layout version, receptacles are only compatible with pin contact and plugs with socket contact.

	Pin contacts		Socket contacts	Piggy back grommet for crimp contacts
	Crimp	PC-Tail	Crimp only	
Coax 50Ω	900130	612570	900140	
Coax 75Ω (PIC V75268 cable type)*	603578	-	603748	
Coax 75Ω (RG 179 cable type)	603838	-	603828	900472
Coax 75Ω (PC Tail)	-	612008	-	
Twinax	077517	600797	077516	
Quadrax 100Ω**	603330	900210	603338	
Octomax	603072	603471	603069	900471

* Also compatible with PIC V76261, PIC73263 and EMTQ TFLX 125-075-01 cable types.
 ** Also compatible with Raychem 10612, EPD44690 and EPD44691 cable types.

Overall dimensions - 387TV 07-05 layout Oval flange receptacle (Pin contact only)



Crimp version

387TV*03**07-05P**

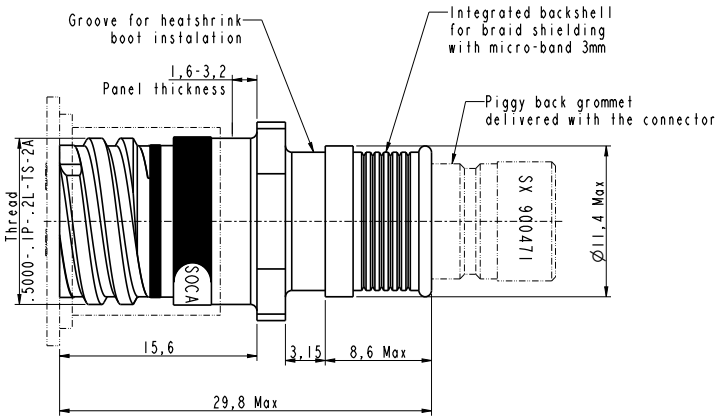

PC-Tail version

387TV*03**CI07-05P

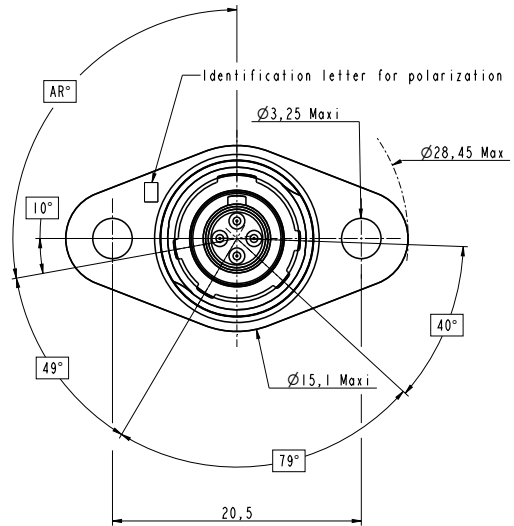
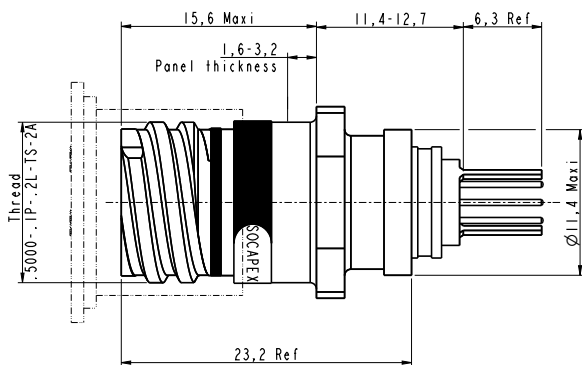

Keyway position according to table page 108

All dimensions are given for information only and are in mm, except as otherwise specified | *in mm: 1mm=0.03937 inch

Due to technical modifications, all information provided is subject to change without prior notice
 Designed by Amphenol Socapex

MIL-DTL-38999 SERIES III DERIVED RANGE - 387TV - SIZE 7 SHELL

Oval flange receptacle equipped with clinch nuts (Pin contact only)



PC tail version

387TV*03**CI07-05P*F506

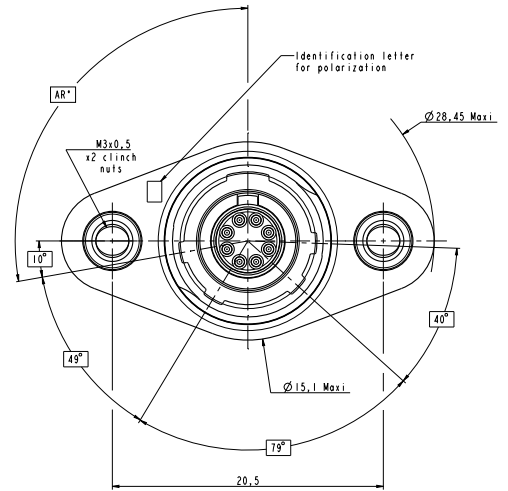
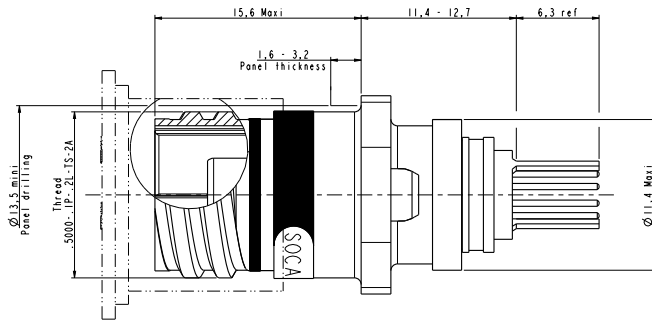

Jam nut receptacle (Pin contact only)



Crimp version

387TV*07**07-05P**

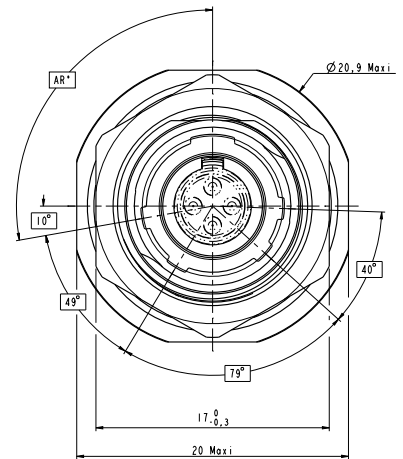
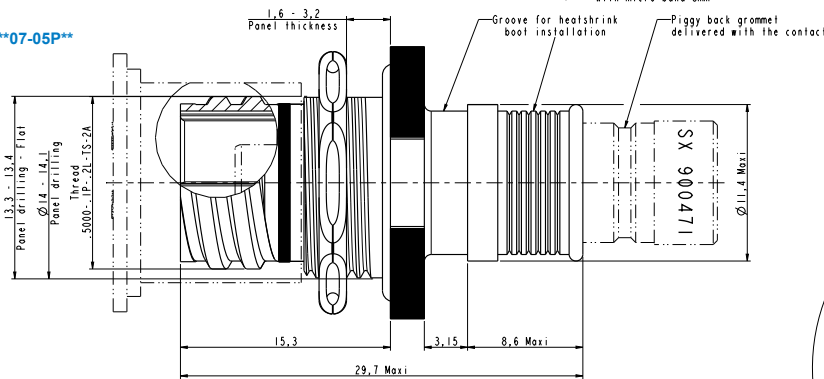

PC tail version

387TV*07**CI07-05P

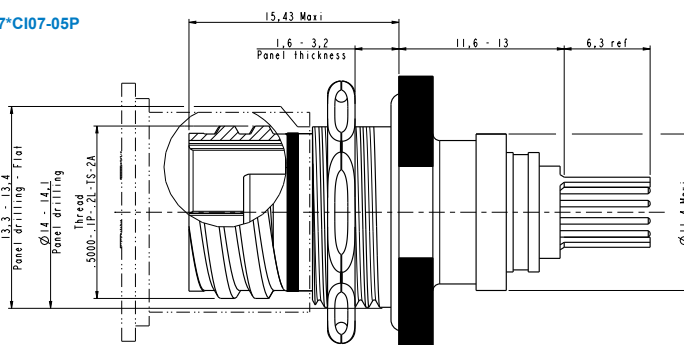

Keyway position according to table page 108.

All dimensions are given for information only and are in mm, except as otherwise specified | *in mm: 1mm=0.03937 inch

Due to technical modifications, all information provided is subject to change without prior notice
Designed by Amphenol Socapex

Series III TV-CTV
Series II JT
Series I LJT
Accessories & tools
Assembly instructions

MIL-DTL-38999 SERIES III DERIVED RANGE - 387TV - SIZE 7 SHELL

Reduced flange Jam nut receptacle (Pin contact only)



Crimp version - Reduced Flange

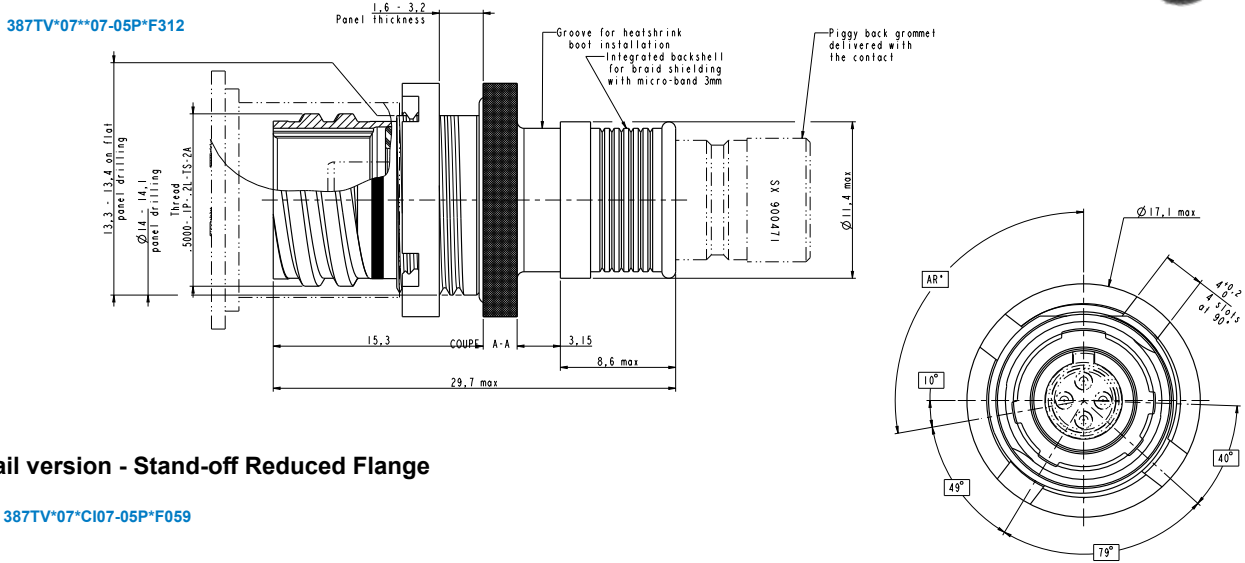

PC-Tail version - Stand-off Reduced Flange

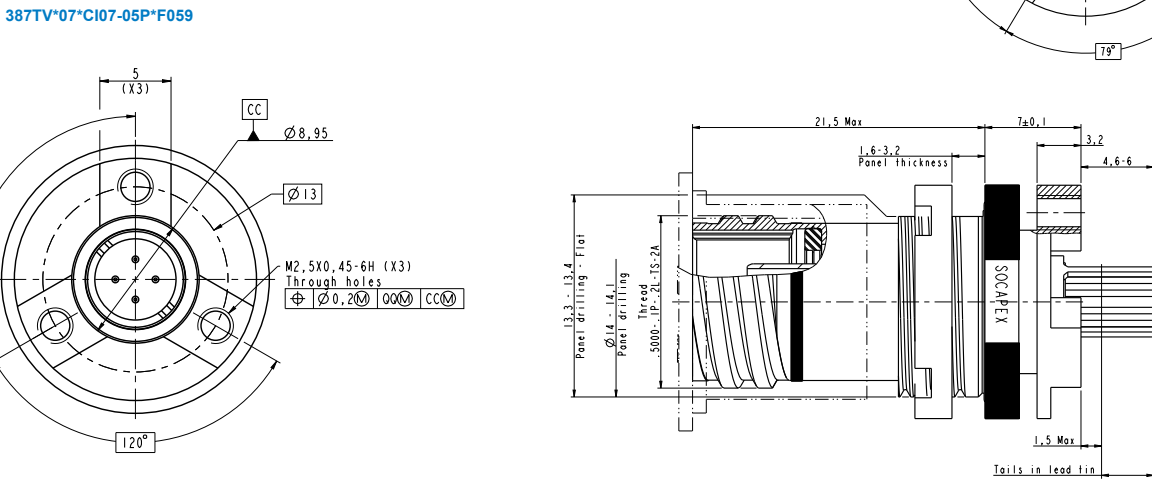

Keyway position according to table page 102

Plug (Socket contact only)

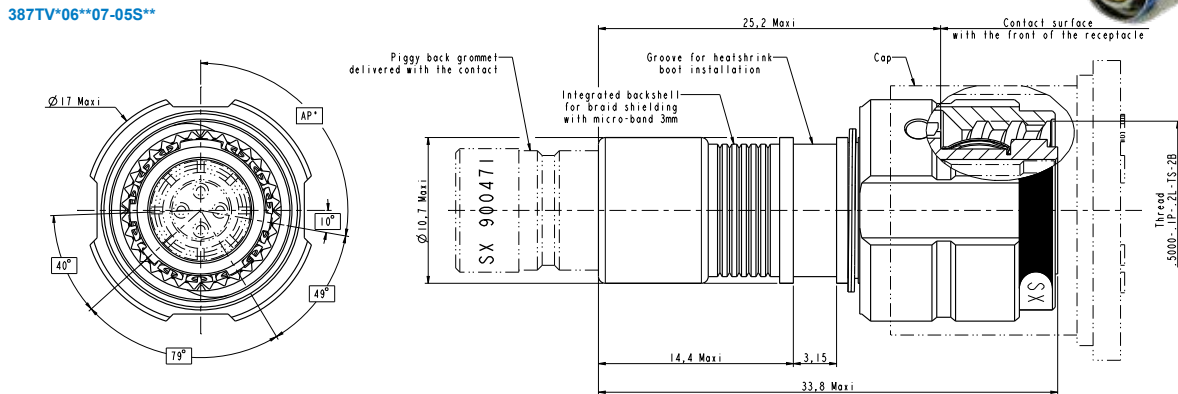

Keyway position according to table page 108.

All dimensions are given for information only and are in mm, except as otherwise specified | *in mm: 1mm=0.03937 inch

Due to technical modifications, all information provided is subject to change without prior notice
Designed by Amphenol Socapex

MIL-DTL-38999 SERIES III DERIVED RANGE - 387TV - SIZE 7 SHELL

Keyway positions - Connectors polarization

The angles for a given connector are the same whether it contains pins or sockets. Master key rotates, minors keys stay fixed. Inserts are not rotated in conjunction with the master key/keyway.

Polarization	AR°
N (Blank)	100°
A	82°
B	72°
C	128°
D	118°

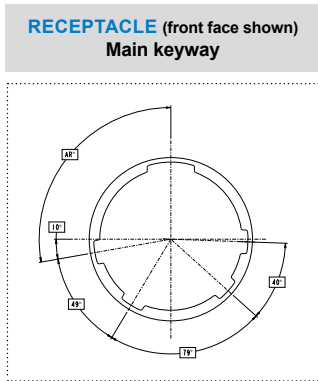

Panel hole dimensions

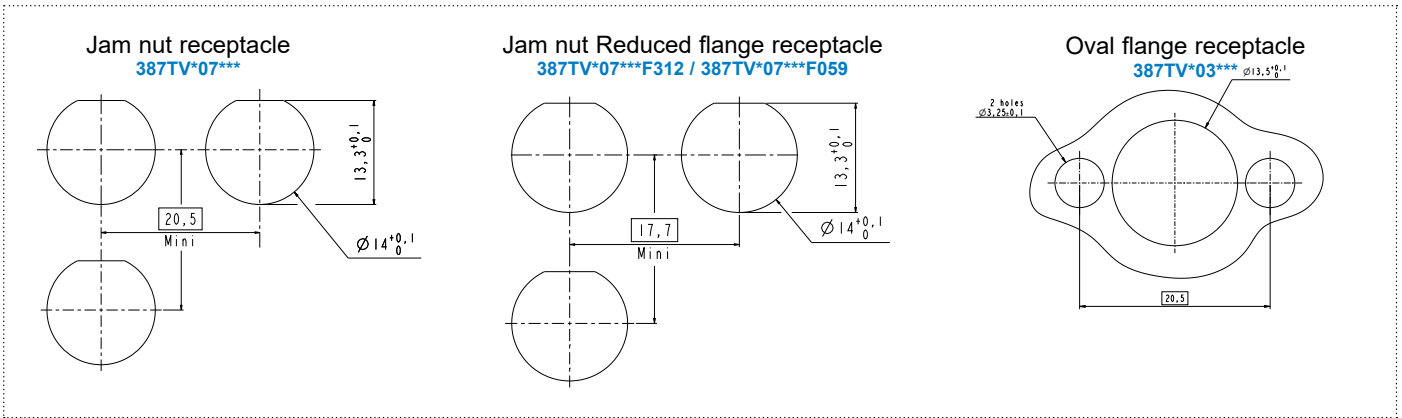

Tool for 387TV Jam nut Reduced flange Castle nut

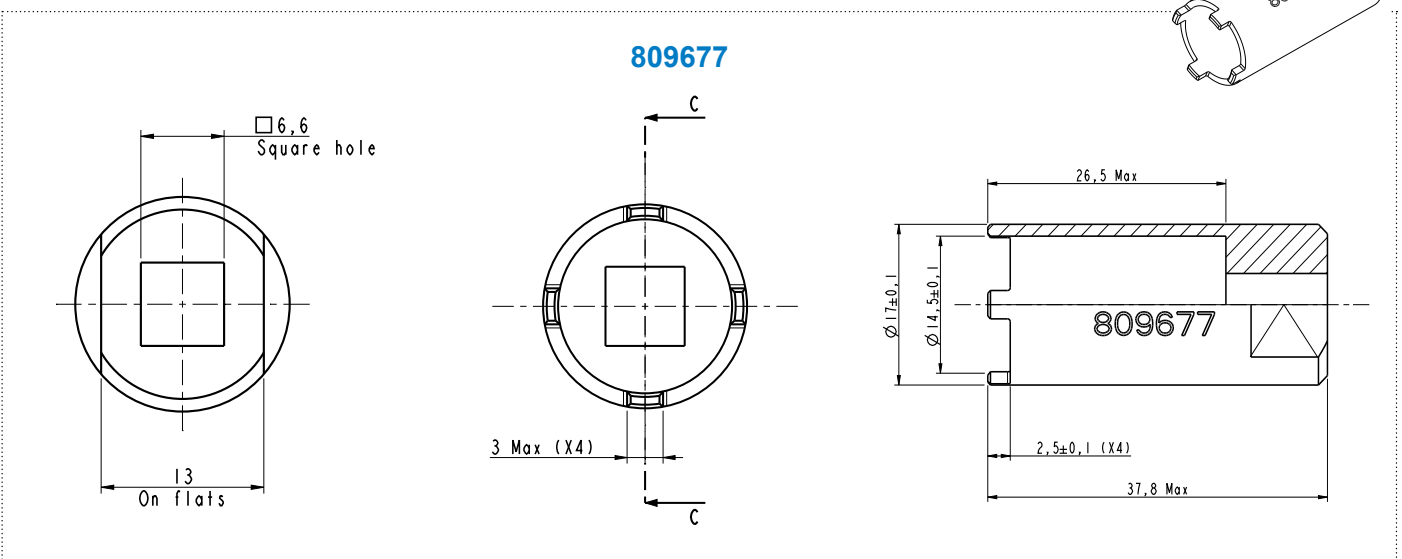

All dimensions are given for information only and are in mm, except as otherwise specified | *in mm: 1mm=0.03937 inch

Due to technical modifications, all information provided is subject to change without prior notice
Designed by Amphenol Socapex

MIL-DTL-38999 SERIES III DERIVED RANGE - 387TV - SIZE 7 SHELL



Metal Caps Size 7 for 387TV Series

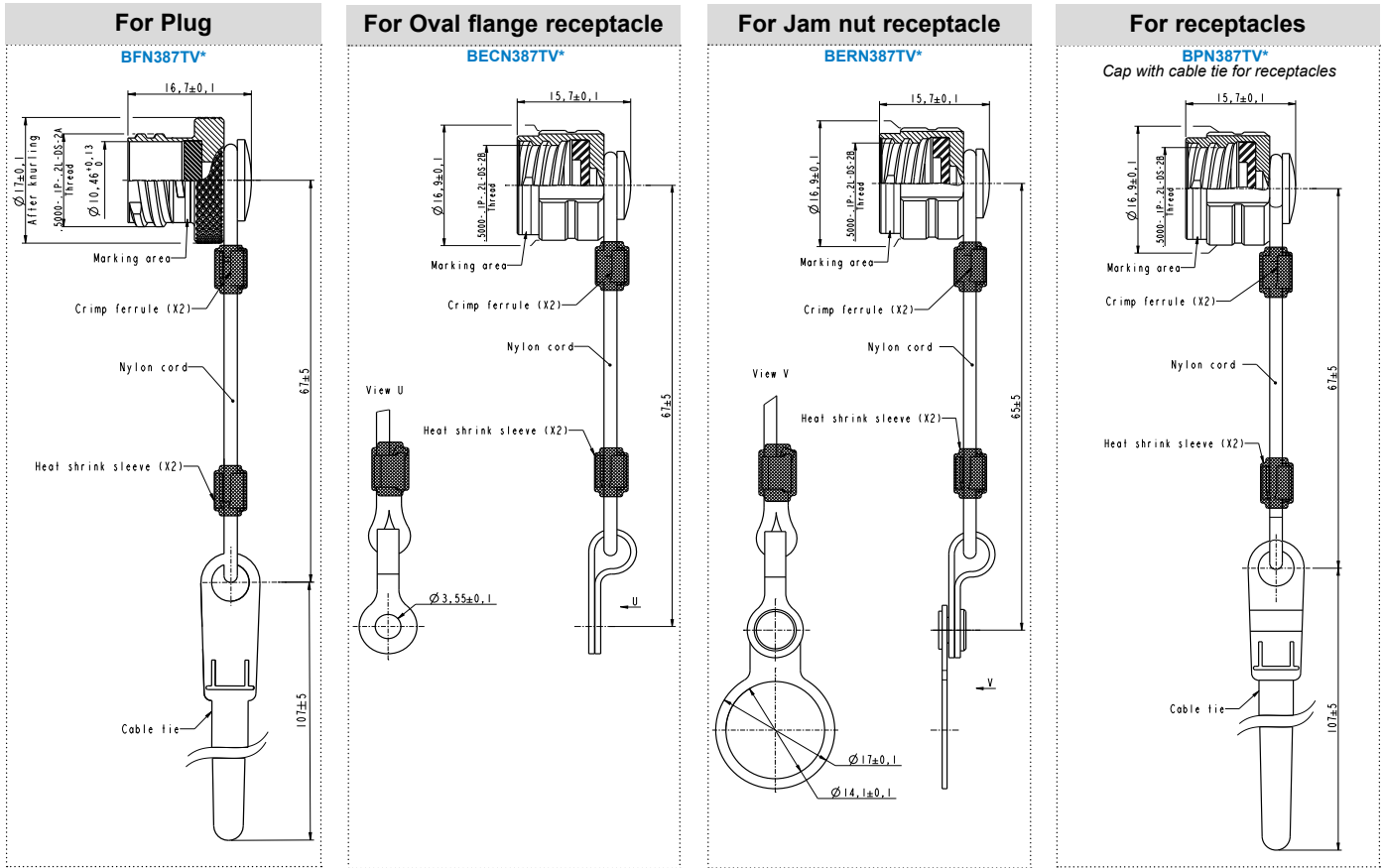

Silicon Caps Size 7 for 387TV Series

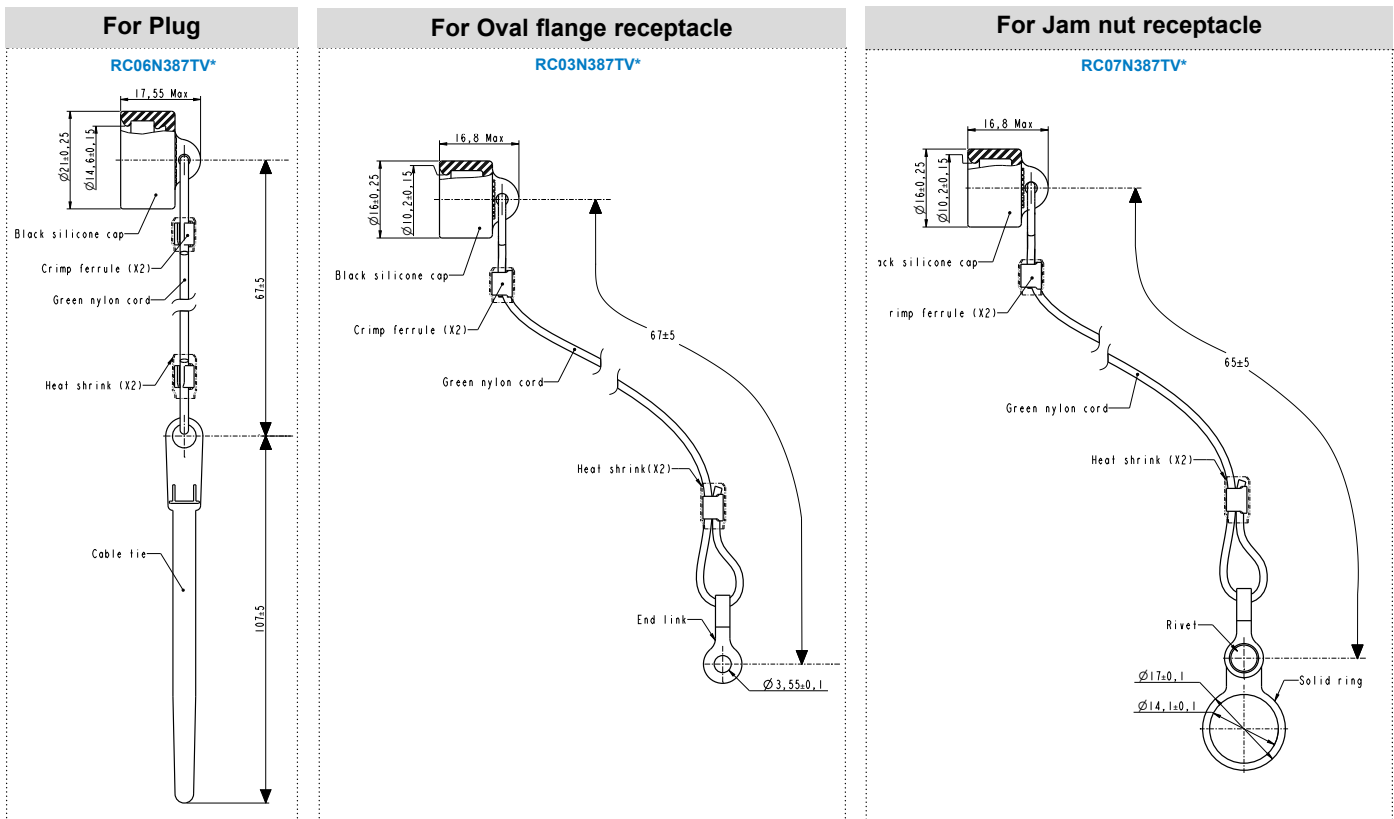

All dimensions are given for information only and are in mm, except as otherwise specified | *in mm: 1mm=0.03937 inch

Due to technical modifications, all information provided is subject to change without prior notice
Designed by Amphenol Socapex

MIL-DTL-38999 SERIES III DERIVED RANGE - 387TV - SIZE 7 SHELL

Panel stopper (Jam nut receptacle) for 387TV Series

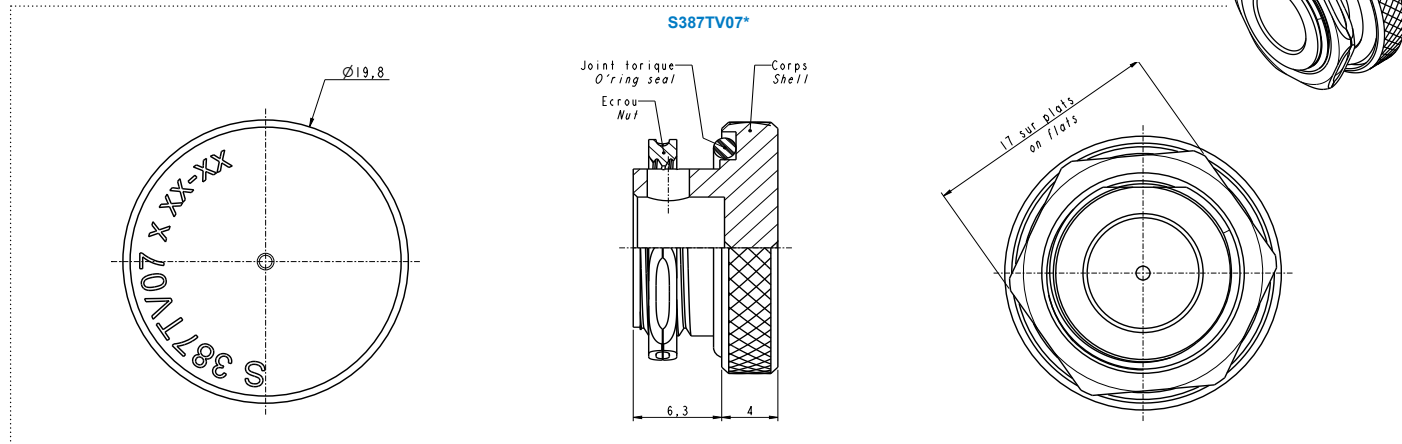
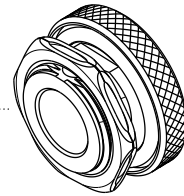

Others accessories

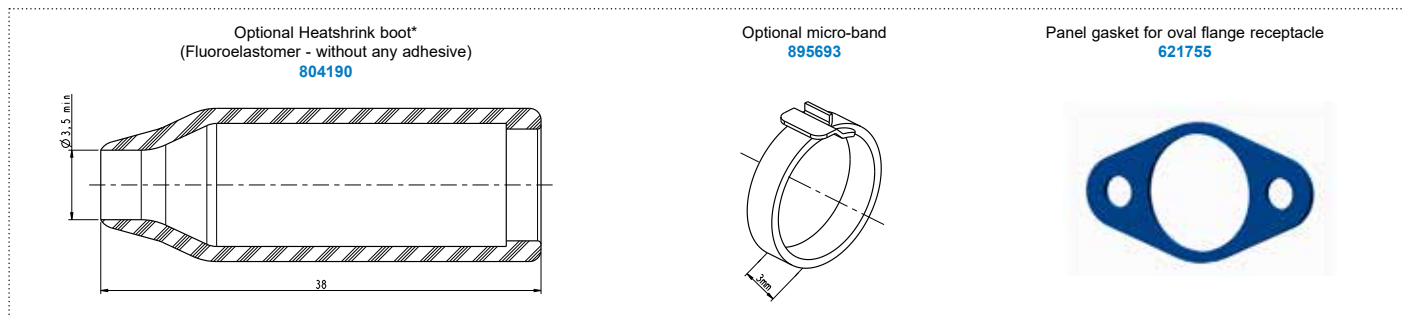

* Shorter piggy back grommet and realignment ring available for the use of heatshrink boot

All dimensions are given for information only and are in mm, except as otherwise specified | *in mm: 1mm=0.03937 inch

Due to technical modifications, all information provided is subject to change without prior notice
Designed by Amphenol Socapex

Series III TV-CTV
Series II JT
Series I LJT
Accessories & tools
Assembly instructions

MIL-DTL-38999 SERIES III DERIVED RANGE - HOW TO ORDER 387TV ACCESSORIES

Amphenol Designations - 387TV Metal Caps

1.	2.	3.	4.	5.	
Cap type - Metal	Cap Style	Wire type	Series	Material and plating	Deviation
B	EC	N	387TV	W	-

1. Cap style

EC	For Oval flange receptacle - Cord with eyelet
ER	For Jam nut receptacle - Cord with ring
P	For receptacle - Cord with cable tie
F	For plug - Cord with cable tie

2. Wire type

N	Nylon Cord
---	------------

3. Series

387TV	Size 7 connector
-------	------------------

4. Material and platings

Shell material	Shell finish
W	Olive drab cadmium
F	Nickel ✓
ZN	Black zinc nickel ✓

5. Deviation

Deviation	Description	Shell type compatibility
F057	For Reduced flange receptacle	F312 / F059
F419	Cap without cord	All

For other deviations, please consult us

Amphenol Designations - 387TV Rubber Cap

1.	2.	3.	4.	
Cap type - Rubber Cap	Cap Style	Wire type	Series	Deviation
RC	EC	N	387TV	-

1. Cap style

03	For Oval flange receptacle - Cord with eyelet
07	For Jam nut receptacle - Cord with ring
06	For plug - Cord with cable tie

2. Wire type

N	Nylon Cord
---	------------

3. Series

387TV	Size 7 connector
-------	------------------

4. Deviation

Deviation	Description	Shell type compatibility
F057	For Reduced flange receptacle	F312 / F059
F419	Cap without cord	All

For other deviations, please consult us

Amphenol Designations - Panel Stopper for 387TV Jam nut receptacle

1.	2.	3.	
Panel Stopper	Series	Style	Material and Plating
S	387TV	N	-

1. Series

387TV	Size 7 connector
-------	------------------

2. Style

07	For Jam nut receptacle
----	------------------------

3. Material and platings

Shell material	Shell finish
W	Olive drab cadmium
F	Nickel ✓
ZN	Black zinc nickel ✓

All dimensions are given for information only and are in mm, except as otherwise specified | *in mm: 1mm=0.03937 inch

Due to technical modifications, all information provided is subject to change without prior notice
Designed by Amphenol Socapex

MIL-DTL-38999 SERIES III DERIVED RANGE - POWERSAFE - VG96944

Power connector qualified VG96944 and designed for user safety



Description

PowerSafe connectors are derived from MIL-DTL-38999 Series III connectors and dedicated to high power supply in harsh environments. These connectors provide the user with the highest user safety, shielding effectiveness & environmental performances. PowerSafe connectors follow the European standard for power equipment DIN EN 61984 (former VDE 0627).



Main features

TWO INSERTS TYPES WITH DIFFERENT CHARACTERISTICS

- "E" inserts – up to 200°C & CTI* <100
Available in Amphenol Proprietary designations only
- "V" inserts – VG96944 compliant – up to 150°C
& CTI* between 175 & 400 (Material Group IIIa)
Available in VG designations & Amphenol Proprietary ones

* (Comparative Tracking Index)

FIRST MATE/LAST BREAK: one earth contact directly linked to the shell, stays in place even in case of overheats.

LAST MATE/FIRST BREAK: one pilot contact with a breaking capacity (brings the information to a relay to turn on/off the power).

These features protect the user even if the connectors are mated or unmated. Amphenol recommends to connect /disconnect connector when unloaded.

IP28 WHEN UNMATED, IP68 WHEN MATED

HIGH ROBUSTNESS AND EXCELLENT ENVIRONMENTAL PERFORMANCES.

SEVERAL MATERIALS & PLATING

- Aluminum (Olive drab Cadmium, Nickel, Black Zinc Nickel, Tin Zinc platings)
- Marine Bronze
- Stainless steel (Passivated, Nickel plated upon request)

EMI/RFI PROTECTION : Shell to shell bottoming and grounding fingers on the plug shell.

ACCESSORIES:

- Caps: compatible with MIL-DTL-38999 Series III caps.
- Backshells: compatible with AS85049 backshells for MIL-DTL-38999 Series III connectors, VG95319-1011G, as well as TV35 & TVNSA backshells.

Same panel drilling as standard MIL-DTL-38999 Series III connectors.

Added benefits

- PowerSafe is compliant with **IP2X Electrical Safety standard**, which guarantees touch-proof protection of live parts.
- Qualified according the most stringent standard **VG96944** (applicable to Aluminum with Olive Drab Cadmium or Tin Zinc finish and Marine Bronze versions only).
- Safety use design following **DIN EN-61984 (former VDE 0627)**.

Concept

- | | |
|------------------------------------|---------------------------------|
| ① Coupling nut | ⑩ Pilot socket contact |
| ② Quick coupling thread | ⑪ Protective socket contact |
| ③ Anti-decoupling device | ⑫ Phase and neutral pin contact |
| ④ Plug shell | ⑬ Pilot pin contact |
| ⑤ Grounding spring | ⑭ Protective pin contact |
| ⑥ Grommet | ⑮ Interfacial seal |
| ⑦ Receptacle shell | ⑯ Socket insert |
| ⑧ Contact retention clips | ⑰ Pin insert |
| ⑨ Phase and neutral socket contact | |

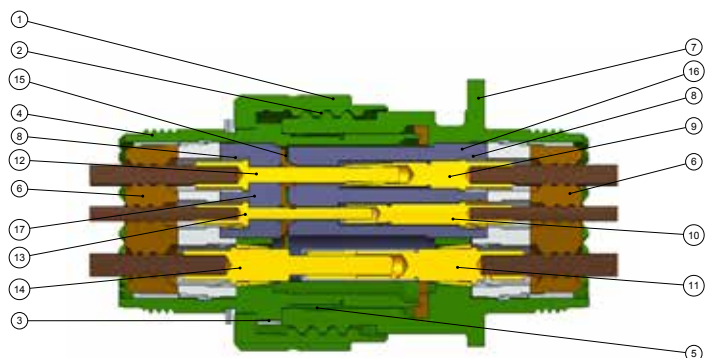

All dimensions are given for information only and are in mm, except as otherwise specified | *in mm: 1mm=0.03937 inch

MIL-DTL-38999 SERIES III DERIVED RANGE - POWERSAFE - VG96944

Amphenol **PowerSafe** range offers 6 contact arrangements to fit all your power needs, with single-phase & three-phase layouts, and a choice of 2 insert materials for each layout depending on the need :

→ **V** inserts : developed according to VG96944 standard with a material less impacted by the disconnection under load. Able to withstand a maximum temperature of 150°C & have a CTI between 175 & 400 (Material Group IIIa)

→ **E** inserts : using the same material than our 38999 series connectors and able to withstand a temperature up to 200°C

Single-Phase Layouts

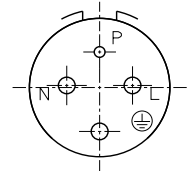
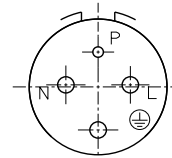
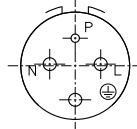
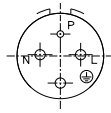

V insert	13-V4	15-V4	21-V4	23-V4
E insert	13-E4	15-E4	21-E4	23-E4
Pilot contact (P)	1 Size 20	1 Size 16	1 Size 16	1 Size 16
Phase & neutral (N & L)	2 Size 16	2 Size 12	2 Size 6	2 Size 4
Protective contact (ground symbol)	1 Size 16	1 Size 12	1 Size 6	1 Size 4

Contact Arrangements	Pilot contact - P		Phase, Neutral and Protective contact - N, L & (ground symbol)		Test voltage AC *
	Contact rating	Operating Voltage AC or DC	Contact rating	Operating Voltage AC or DC	
13-V4 / 13-E4	0,5 A	60 V	16 A	250 V	1500 V
15-V4 / 15-E4	0,5 A	60 V	25 A	250 V	1500 V
21-V4 / 21-E4	0,5 A	60 V	63 A	500 V	2500 V
23-V4 / 23-E4	0,5 A	60 V	100 A	500 V	2500 V

Three-Phase Layouts

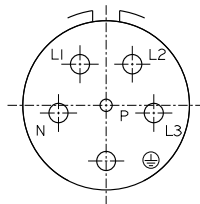
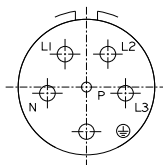

V insert	17-V6	25-V6
E insert	17-E6	25-E6
Pilot contact	1 Size 16	1 Size 16
Phase & neutral	4 Size 12	4 Size 6
Protective contact	1 Size 12	1 Size 6

Contact Arrangements	Pilot contact - P		Phase, Neutral and Protective contact - N, L1, L2, L3 & (ground symbol)		Test voltage AC *
	Contact rating	Operating Voltage AC or DC	Contact rating	Operating Voltage AC or DC	
17-V6 / 17-E6	0,5 A	60 V	25 A	500 V	2500 V
25-V6 / 25-E6	0,5 A	60 V	63 A	500 V	2500 V

*Note : Test voltage in mated condition for Phase, Protective and Neutral pin & socket contacts, and Pilot pin contacts.

Test voltage in unmated condition for Pilot socket contact only

All dimensions are given for information only and are in mm, except as otherwise specified | *in mm: 1mm=0.03937 inch

MIL-DTL-38999 SERIES III DERIVED RANGE - POWERSAFE - VG96944

Environmental characteristics

	Connectors with Proprietary inserts E	Connectors with VG96944 compliant inserts V
Temperature	-65 to +175°C (Olive drab cadmium, Tin Zinc, Black zinc nickel plating) -65 to + 200°C (Nickel plating, Marine Bronze, Stainless steel)	-65 to +150°C (all materials and platings)
Salt spray exposure	48h for Nickel plated Aluminum 500h for Olive drab cadmium, Black zinc nickel, Tin Zinc and Stainless steel 1000h for Marine Bronze	Test level 2 : 5% NaCl. 2h salt spray exposure and 22h storage in humid air repeated during 5 cycles
Sealing	IP28: - Finger test for socket contacts and socket inserts - Pressure water tight (48h, under 2m water)	IP28: - Finger test for socket contacts and socket inserts - Pressure water tight (48h, under 2m water)

Mechanical characteristics

	Connectors with Proprietary inserts E	Connectors with VG96944 compliant inserts V
Durability	500 mating cycles	500 mating cycles
Shocks	-	Half-sine, 500 m/s ² , 11 ms
Sine vibrations	60g from -55 +175°C (Olive drab cadmium) / + 200°C (Nickel)	-
Random vibrations	Per EIA-364-28	Per VG95319-2 (Spectrum 5 Hz to 500 Hz)
Insert material	Thermoplastic insert Silicone rubber grommet and interfacial seal	Thermoplastic insert Silicone rubber grommet and interfacial seal
Insulator material Comparative Tracking Index	<100V	<400V
Contacts	Crimp, removable contacts Gold plating for pilot contact and silver plating for protective, phase and neutral contacts	Crimp, removable contacts Gold plating for pilot contact and silver plating for protective, phase and neutral contacts
Protective contact Resistance	≤100 mΩ	≤100 mΩ

Contact retention force

Contact Size	20	16	12	6	4
Maximum load (N)	67	111	111	111	150

All dimensions are given for information only and are in mm, except as otherwise specified | *in mm: 1mm=0.03937 inch

MIL-DTL-38999 SERIES III DERIVED RANGE - HOW TO ORDER POWERSAFE

Amphenol Designations - PowerSafe connectors

Series	Shell type	Crimp contacts	Class	Contact arrangement	Contact gender	Keying	Deviation
TV	P00	R	W	13-E4	P	A	-

1. Shell type

	Shell type	Temperature	Associated materials and platings for E inserts	Associated materials and platings for V inserts
06	Straight plug	+175°C*	W, ZN, ZR, TZ	W, ZN, ZR, TZ, F, K, S, B
S06		+200° C	F, K, S, B	-
P00	Square flange receptacle	+175°C*	W, ZN, ZR, TZ	W, ZN, ZR, TZ, F, K, S, B
PS00		+200° C	F, K, S, B	-
07	Jam nut receptacle	+175°C*	W, ZN, ZR, TZ	W, ZN, ZR, TZ, F, K, S, B
S07		+200° C	F, K, S, B	-

2. Crimp contacts

R For Class W, F, K and B platings

Blank For Class ZN, ZR and TZ platings

3. Class: Material & Finish

	Shell material	Shell finish
W	Aluminum	Olive drab cadmium
F		Nickel ✓
ZN		Black zinc nickel ✓
ZR		Black zinc nickel without Chromium 6+ ✓
TZ		Tin Zinc ✓
B	Marine bronze ✓	-
K	Stainless steel	Passivated ✓
S		Nickel ✓

4. Contact arrangement

13-E4	Size 13 – 4 contacts
15-E4	Size 15 – 4 contacts
17-E6	Size 17 – 6 contacts
21-E4	Size 21 – 4 contacts
23-E4	Size 23 – 4 contacts
25-E6	Size 25 – 6 contacts

Please note that standard inserts have a Comparative Tracking Index (CTI) <100V and can withstand a temperature up to 200°C depending on shell material and platings.

13-V4	Size 13 – 4 contacts
15-V4	Size 15 – 4 contacts
17-V6	Size 17 – 6 contacts
21-V4	Size 21 – 4 contacts
23-V4	Size 23 – 4 contacts
25-V6	Size 25 – 6 contacts

Please note that VG inserts have a Comparative Tracking Index (CTI) between 175 & 400V (Material Group IIIa) and can withstand a temperature up to 150°C.

5. Contact gender

P	Pin (500 cycles)
S	Socket (500 cycles)

6. Keying

(Blank) (for normal)	A	B	C	D
-------------------------	---	---	---	---

7. Deviation

Deviation	Description	Shell type compatibility
F312	Reduced flange receptacle with a standard nut	07/S07

For other deviations availability, please consult us

POWERSAFE / VG96944 - HOW TO ORDER - TV35 BACKSHELLS

Series	Backshell style	Backshell size	Cabling chamber length	Rear side diameter	Material and platings	Deviation
TV	35	11	10	11	014	-

1. Backshell style

35	Aluminum straight band backshell accepting heatshrink moulded piece
B35	Marine bronze straight band backshell accepting heatshrink moulded piece

2. Backshell size (same as connector size)

13	15	17	21	23	25
----	----	----	----	----	----

3. Cabling chamber length

Please refer to Page 106
10

4. Rear side diameter

Please refer to Page 15

06	08	10	12	14	16	20	24	28	32	36
----	----	----	----	----	----	----	----	----	----	----

5. Material and platings

	Shell material	Shell finish
014	Aluminum	Olive drab cadmium
023		Nickel ✓
076		Tin Zinc ✓
033K		Black zinc nickel ✓
Blank	Marine Bronze ✓	-

6. Deviation

F479	Mandatory fo Tin Zinc plated backshells in addition to TZ
------	---

✓ RoHS compliant

All dimensions are given for information only and are in mm, except as otherwise specified | *in mm: 1mm=0.03937 inch

MIL-DTL-38999 SERIES III DERIVED RANGE - HOW TO ORDER POWERSAFE

VG96944 Designations - PowerSafe connectors

1.	2.	3.	4.	5.	
Series	Shell type	Contact arrangement	Contact gender	Keying	Material and platings
VG96944-04	A	13-V4	P	N	A

1. Shell type

A	Receptacle	Square flange receptacle
B		Jam nut receptacle
C	Straight plug	

2. Contact arrangement

13-V4	Size 13 - 4 contacts
15-V4	Size 15 - 4 contacts (qualification to come)
17-V6	Size 17 - 6 contacts
21-V4	Size 21 - 4 contacts (qualification to come)
23-V4	Size 23 - 4 contacts (qualification to come)
25-V6	Size 25 - 6 contacts

Please note that VG inserts have a Comparative Tracking Index (CTI) between 175 & 400V (Material Group IIIa) and can withstand a temperature up to 150°C.

3. Contact gender

P	Pin (500 cycles)
S	Socket (500 cycles)

4. Keying

N (for normal)	A	B	C	D
-------------------	---	---	---	---

5. Material and platings

	Shell material	Shell finish
A	Aluminum	Olive drab cadmium (13-V4/17-V6/25-V6 only)
J		Tin Zinc ✓ (Qualification in progress)
B	Marine bronze ✓	-

Amphenol Designations - Powersafe Dummy receptacles

1.	2.	3.	4.	
Dummy receptacle	Style	Series	Material and platings	Shell size
SE	00	TVE	W	13

1. Style

00	Square flange
----	---------------

2. Series

TVE	For PowerSafe
-----	---------------

3. Material and platings

	Shell material	Shell finish
W	Aluminum	Olive drab cadmium
F		Nickel ✓
ZN		Black zinc nickel ✓
ZR		Black Zinc Nickel without CR6+ ✓
TZ		Tin Zinc ✓
B	Marine bronze ✓	-

4. Shell size

13	15	17	21	23	25
----	----	----	----	----	----

✓ RoHS compliant

All dimensions are given for information only and are in mm, except as otherwise specified | *in mm: 1mm=0.03937 inch

Series III TV-CTV
Series II JT
Series I LJT
Accessories & tools
Assembly instructions

MIL-DTL-38999 SERIES III DERIVED RANGE - POWERSAFE - VG96944

Overall dimensions Square flange receptacle

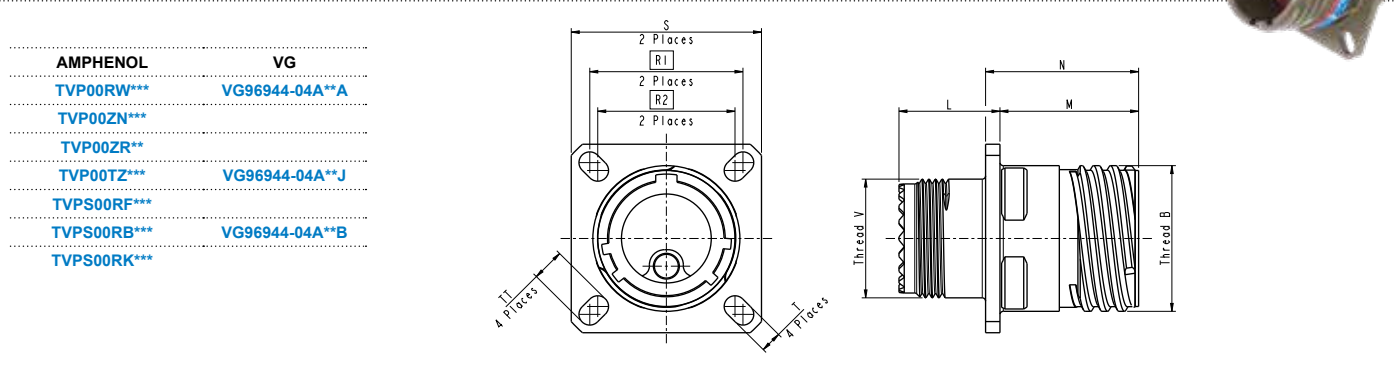

AMPHENOL	VG
TVP00RW***	VG96944-04A**A
TVP00ZN***	
TVP00ZR**	
TVP00TZ***	VG96944-04A**J
TVPS00RF***	
TVPS00RB***	VG96944-04A**B
TVPS00RK***	

Shell size	B thread Class 2A (inches)	L Max (mm)	M Max (mm)	N +0.13 0 (mm)	R1 (mm)	R2 (mm)	S ±0.3 (mm)	T ±0.2 (mm)	TT ±0.2 (mm)	V thread (metric)
13	.875	15.5	20.9	22.99	23.01	20.62	28.6	3.25	4.93	M18x1-6g
15	1.0000	15.5	23.3	25.49	24.61	23.01	31.0	3.25	4.39	M22x1-6g
17	1.1875	15.6	23.4	25.49	26.97	24.61	33.3	3.25	4.93	M25x1-6g
21	1.3750	17.5	24.6	27.49	31.75	29.36	39.7	3.25	4.93	M31x1-6g
23	1.5000	20.7	24.6	27.49	34.93	31.75	42.9	3.91	4.93	M34x1-6g
25	1.625	20.7	24.6	27.49	38.10	34.93	46.0	3.91	6.15	M37x1-6g

Jam nut receptacle

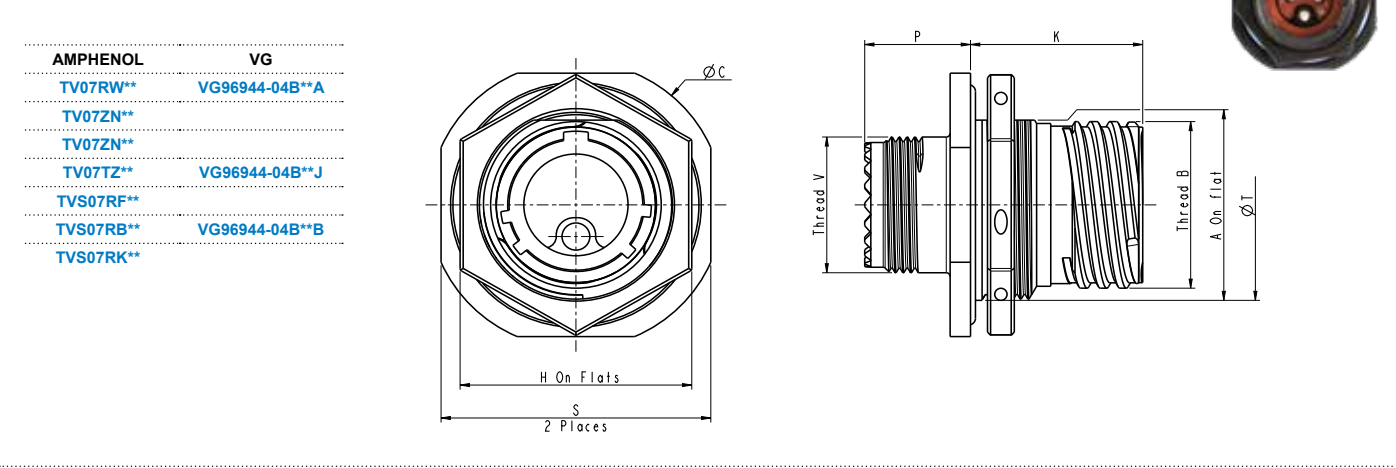

AMPHENOL	VG
TV07RW**	VG96944-04B**A
TV07ZN**	
TV07ZT**	VG96944-04B**J
TVS07RF**	
TVS07RB**	VG96944-04B**B
TVS07RK**	

Shell size	B thread Class 2A (inches)	A +0.1 -0.15 (mm)	C Max (mm)	K Max (mm)	P Max (mm)	H Hex 0 -0.1 (mm)	S +/-0.4 (mm)	T (mm)	V thread (metric)	Hex nut max torque (N.m)
13	.875	23.82	38.4	22.5	13.7	30	34.9	25.20 - 25.50	M18x1-6g	20
15	1.0000	26.97	41.6	25.0	14.1	34	38.1	28.30 - 28.60	M22x1-6g	
17	1.1875	30.15	44.8	25.0	14.1	36	41.3	31.80 - 31.95	M25x1-6g	30
21	1.3750	36.50	25.7	27.0	18.5	46	49.2	37.97 - 37.80	M31x1-6g	
23	1.5000	39.67	55.9	27.0	18.5	46	52.4	41.00 - 41.30	M34x1-6g	
25	1.625	42.85	59.0	27.0	18.5	50	55.6	44.20 - 44.5	M37x1-6g	40

All dimensions are given for information only and are in mm, except as otherwise specified | *in mm: 1mm=0.03937 inch

Due to technical modifications, all information provided is subject to change without prior notice
Designed by Amphenol Socapex

MIL-DTL-38999 SERIES III DERIVED RANGE - POWERSAFE - VG96944

Straight plug



AMPHENOL	VG
TV06RW**	VG96944-04C**A
TV06ZN**	
TV06ZR**	
TV06TZ**	VG96944-04C**J
TVS06RF**	
TVS06RB**	VG96944-04C**B
TVS06RK**	

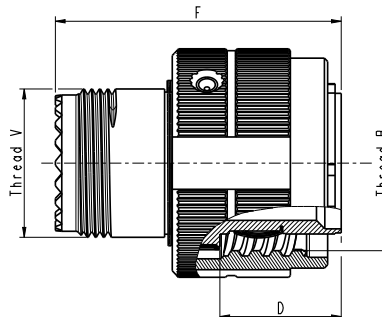
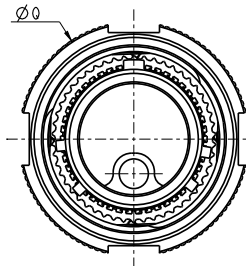

Conforms to CECC 75.201.002 (coupling nut for arctic gloves)

Shell size	B thread Class 2B (inches)	Q Max (mm)	F Max (mm)	D (mm)	V thread (metric)
13	.875	29.4	35.5	15.01	M18x1-6g
15	1.0000	32.5	38.0	17.51	M22x1-6g
17	1.1875	35.7	38.0	17.51	M25x1-6g
21	1.3750	38.5	44.4	19.51	M31x1-6g
23	1.5000	44.9	46.0	19.51	M34x1-6g
25	1.625	48.0	46.0	19.51	M37x1-6g

All dimensions are given for information only and are in mm, except as otherwise specified | *in mm: 1mm=0.03937 inch

Series III TV-CTV
Series II JT
Series I LJT
Accessories & tools
Assembly instructions

MIL-DTL-38999 SERIES III DERIVED RANGE - POWERSAFE - VG96944

Keyway polarization

A plug with a given rotation letter will mate with a receptacle with the same rotation letter. The angles for a given connector are the same whether it contains pins or sockets. Minor keys stay fixed, master key rotates.

Keyway identification letter is (Blank) for Normal, A, B, C or D.

Size	Position of the major key					RECEPTACLE (front face shown)	PLUG (front face shown)
	NORMAL BLANK	A	B	C	D		
13	100	80	68	132	120		
15	100	79	66	134	121		
17	100	82	70	130	118		
21	100	82	70	130	118		
23	100	85	74	126	115		
25	100	85	74	126	115		

Panel hole dimensions

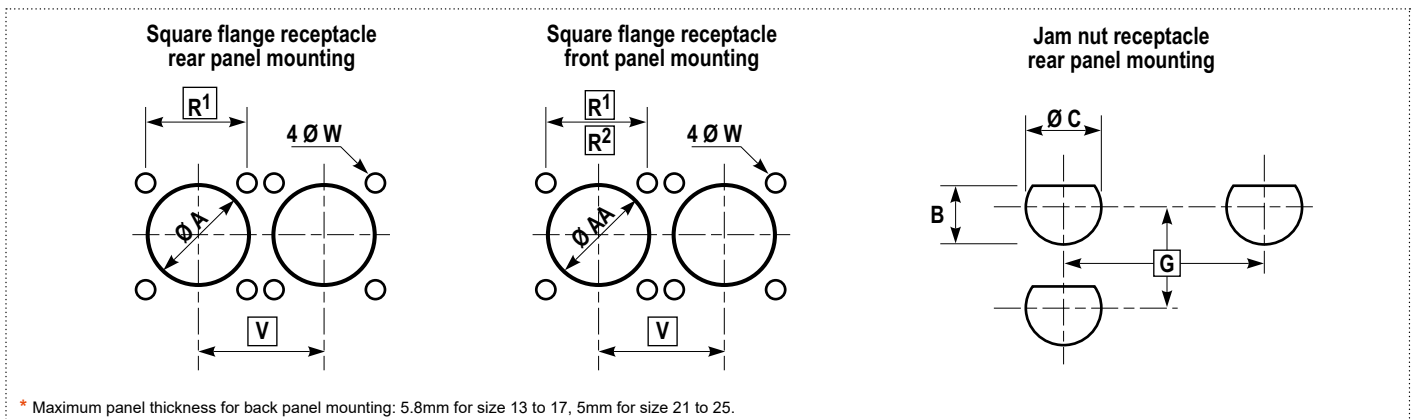

Shell size	R ¹ (mm)	R ² (mm)	V Mini (mm)	ØA Min (mm)	ØAA Min (mm)	ØW ±0.13 (mm)	G Mini (mm)	ØC +0.25 0 (mm)	B 0 -0.25 (mm)
13	23.01	20.62	30.20	23.42	19.05	3.25	36.00	25.65	24.26
15	24.61	23.01	33.30	26.59	23.01	3.25	39.60	28.83	27.56
17	26.97	24.61	36.50	30.96	25.81	3.25	43.30	32.01	30.73
21	31.75	29.36	42.50	36.12	32.16	3.25	50.60	38.35	37.08
23	34.93	31.75	45.70	39.29	34.93	3.81	54.20	41.53	40.26
25	38.10	34.93	48.80	42.47	37.69	3.81	59.70	44.70	43.43

All dimensions are given for information only and are in mm, except as otherwise specified | *in mm: 1mm=0.03937 inch

MIL-DTL-38999 SERIES III DERIVED RANGE - POWERSAFE - VG96944

Reduced flange receptacle are derived from 38999 series III Jam nut receptacles and dedicated for applications where size & weight are criticals, offering un smaller footprint and lower weight.

Main features

- For Jam nut receptacle (TV07/TVS07).
- Higher density on panel: **41% average footprint surface reduction.**
- Lighter: **20% average lighter than standard 38999**
- Mates with standard **PowerSafe** plug and caps.
- Matches the **PowerSafe** performances.
- Improved design of the o'ring groove allowing the o'ring to stay in place.



MATED PAIR

RECEPTACLE FRONT FACE

Standard
TV*07***

Jam nut
Reduced flange
TV*07***F312



Footprint savings

Average 41% footprint reduction:

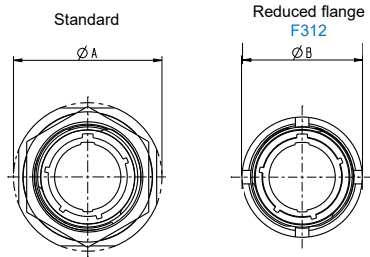

Size	Standard PowerSafe ØA _{MAX} (mm)	PowerSafe Reduced flange (F312) ØB _{MAX} (mm)	Ø Reduction
13	38.4	28.1	46%
15	41.6	32.1	40%
17	44.8	36.1	35%
21	52.7	41.1	39%
23	55.9	44.1	38%
25	59	48.1	34%

All others dimensions remains the same in standard or reduced flange (lengths, threads, etc.).

Panel hole dimensions

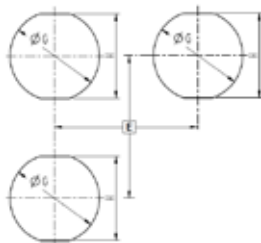

Size	E recommended	ØG +0.1 0	H +0.1 0
13	31.4	23	22.3
15	34.5	27	25.5
17	37.7	31	30.3
21	43.7	36	35.1
23	46.9	39	38.3
25	51.0	43	41.5

Tooling

Specific tool for castle nut

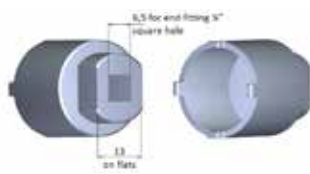

Size	Tool reference
13	809683
15	809684
17	809685
21	809687
23	809688
25	809689

All dimensions are given for information only and are in mm, except as otherwise specified | *in mm: 1mm=0.03937 inch

Series III TV-CTV
Series II JT
Series I LJT
Accessories & tools
Assembly instructions

MIL-DTL-38999 SERIES III DERIVED RANGE - POWERSAFE - VG96944

- Dedicated to **PowerSafe**
- Universal coding : Compatible with all Keyway polarizations
- Can be used as a backshell tightening tool
- Same dimensions and Panel holes than a standard Square Flange Receptacle (see page 109).

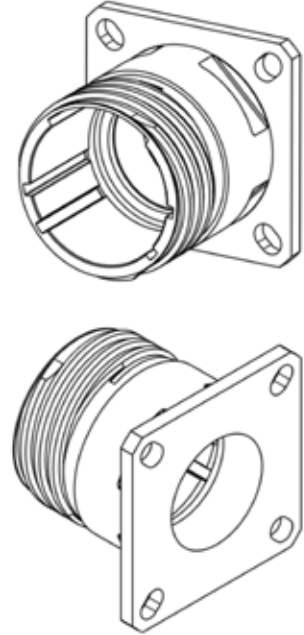
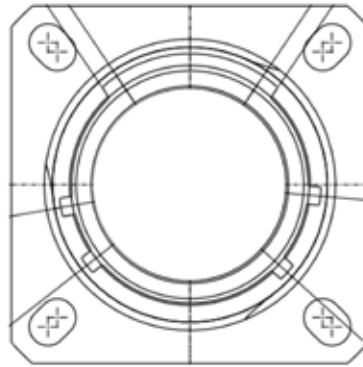
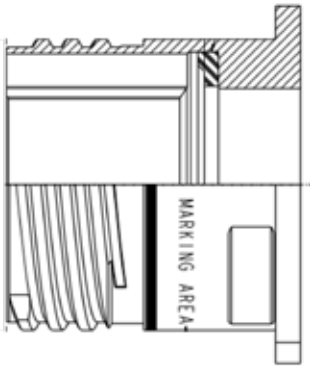

All dimensions are given for information only and are in mm, except as otherwise specified | *in mm: 1mm=0.03937 inch

Due to technical modifications, all information provided is subject to change without prior notice
Designed by Amphenol Socapex

MIL-DTL-38999 SERIES III DERIVED RANGE - POWERSAFE - VG96944

Series III TV-CTV
Series II JT
Series I LJT
Accessories & tools
Assembly instructions

Contact type	Size	Contacts		AWG	Section mm ²	dia over insulator		Crimping tools			Insertion tools			Removal tools					
		Proprietary Part Number				Min	Max	Tools	Positioner	Selector position	Plastic (Color)	Metallic		Plastic (Color)	Metallic				
		Pin	Socket									Straight type	Angle type		Straight type	Angle type			
13-V4 13-E4	Pilot Phase Neutral Protective	20 16	600665 600666 600667	600892 600676 600677	22 14 18	0,61 1,23 0,96	0,38 0,61	1,02 1,65	2,11 2,77	M22520/1-01 M22520/1-01	M22520/1-04 M22520/1-04	3 2 1 6 6 5 4	M81969/14-10 (red / orange) M81969/14-03 (blue / white) /	809817 809816	M81969/8-05 M81969/8-07	M81969/14-10 (red / orange) M81969/14-03 (blue / white) /	809847 809846	M81969/8-06 M81969/8-08	
15-V4 15-E4	Pilot Phase Neutral Protective	16 12	600660 600661 600662	600894 600671 600672	16 12 14	1,23 2,98 1,94	0,96 0,61	1,65 2,46	2,77 3,61	M22520/1-01 M22520/1-01	M22520/1-04 M22520/1-04	6 5 4 8 7	M81969/14-03 (blue / white) M81969/14-04 (yellow / white) /	809816 /	M81969/8-07 M81969/8-09	M81969/14-03 (blue / white) M81969/14-04 (yellow / white) /	809846 /	M81969/8-08 M81969/8-10	
17-V6 17-E6	Pilot Phase Neutral Protective	16 12	600660 600661 600662	600894 600671 600672	16 12 14	1,23 2,98 1,94	0,96 0,61	1,65 2,46	2,77 3,61	M22520/1-01 M22520/1-01	M22520/1-04 M22520/1-04	6 5 4 8 7	M81969/14-03 (blue / white) M81969/14-04 (yellow / white) /	809816 /	M81969/8-07 M81969/8-09	M81969/14-03 (blue / white) M81969/14-04 (yellow / white) /	809846 /	M81969/8-08 M81969/8-10	
21-V4 21-E4	Pilot Phase Neutral Protective	16 6	600660 600663 600664	600894 600673 600674	16 6	1,23 13,61	0,96 7,3	2,77 8,1	M22520/1-01 809947 + 809908 (hex crimp) or M22520/23-01 + 809697 (pin) M22520/23-03 + 809690 (socket)	M22520/1-04		6 5 4	M81969/14-03 (blue / white)	/	/	M81969/14-03 (blue / white)	/	/	809696
23-V4 23-E4	Pilot Phase Neutral Protective	16 4	600660 612514 612513	600894 612516 612515	16 4	1,23 21,2	0,96 0,61	1,65	2,77	M22520/1-01 M22520/23-01	M22520/1-04 M22520/23-04	6 5 4	M81969/14-03 (blue / white)	/	/	M81969/14-03 (blue / white)	/	/	809943
25-V6 25-E6	Pilot Phase Neutral Protective	16 6	600660 600663 600664	600894 600673 600674	16 6	1,23 13,61	0,96 7,3	2,77 8,1	M22520/1-01 809947 + 809908 (hex crimp) or M22520/23-01 + 809697 (pin) M22520/23-03 + 809690 (socket)	M22520/1-04		6 5 4	M81969/14-03 (blue / white)	/	/	M81969/14-03 (blue / white)	/	/	809696

CRIMPING TOOLS

MANUAL CRIMPING PLIERS
M22520/1-01



HYDRAULIC PLIERS
809947



PNEUMATIC PLIERS
M22520/23-01



All dimensions are given for information only and are in mm, except as otherwise specified | *in mm: 1mm=0.03937 inch

Due to technical modifications, all information provided is subject to change without prior notice
Designed by Amphenol Socapex

MIL-DTL-38999 SERIES III DERIVED RANGE - POWERSAFE - VG96944

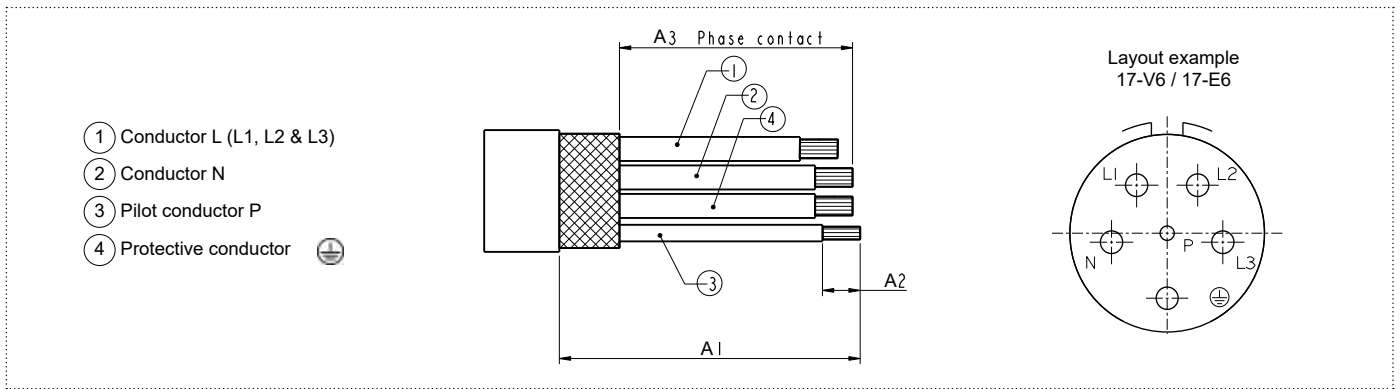

Size	Contact type	A1	A2	A3 (for shielding braid)
13	Protective contact	53 - 63	6 - 6.5	42 _{MAX}
	Phase contacts (N, L1, L2 & L3)			
	Pilot contact (P)			
15	Protective contact	53 - 63	6 - 6.5	
	Phase contacts (N, L1, L2 & L3)			
	Pilot contact (P)			
17	Protective contact	53 - 63	6 - 6.5	
	Phase contacts (N, L1, L2 & L3)			
	Pilot contact (P)			
21	Protective contact	55 - 65	14 - 15.5	
	Phase contacts (N, L1, L2 & L3)			
	Pilot contact (P)			
23	Protective contact	55 - 65	14 - 15.5	
	Phase contacts (N, L1, L2 & L3)			
	Pilot contact (P)			
25	Protective contact	55 - 65	14 - 15.5	
	Phase contacts (N, L1, L2 & L3)			
	Pilot contact (P)			

All dimensions are given for information only and are in mm, except as otherwise specified | *in mm: 1mm=0.03937 inch

Due to technical modifications, all information provided is subject to change without prior notice
 Designed by Amphenol Socapex

MIL-DTL-38999 SERIES III DERIVED RANGE - POWERSAFE - VG96944

Size 13	PN	Raw material
WIRE AWG16 white	VG95218T020A003	Tinned copper, jacket PVF modified
WIRE AWG14 white	M81044/12-14-9	Tinned copper, jacket PVDF
WIRE AWG14 blue	M81044/12-14-6	Tinned copper, jacket PVDF
WIRE AWG14 green yellow	M81044/12-14-45	Tinned copper, jacket PVDF
Fillers	-	PTFE
Braid	TB13-T-63	Tinned copper
Heatshrink	DR25 3/8-0M (VG95343 Part 5 Type D)	Elastomer
Size 15	PN	Raw material
WIRE AWG16 white	VG95218T020A003	Tinned copper, jacket PVF modified
WIRE AWG12 white	VG95218T020A017	Tinned copper, jacket PVF modified
WIRE AWG12 blue	M81044/12-12-6	Tinned copper, jacket PVDF
WIRE AWG12 green yellow	M81044/12-12-45	Tinned copper, jacket PVDF
Fillers	-	PTFE
Braid	TB13-T-695	Tinned copper
Heatshrink	DR25 1/2-0M (VG95343 Part 5 Type D)	Elastomer
Size 17	PN	Raw material
WIRE AWG16 white	VG95218T020A003	Tinned copper, jacket PVF modified
WIRE AWG12 white	VG95218T020A017	Tinned copper, jacket PVF modified
WIRE AWG12 blue	M81044/12-12-6	Tinned copper, jacket PVDF
WIRE AWG12 green yellow	M81044/12-12-45	Tinned copper, jacket PVDF
Fillers	-	PTFE
Braid	TB13-T-695	Tinned copper
Heatshrink	DR25 1/2-0M (VG95343 Part 5 Type D)	Elastomer
Size 21	PN	Raw material
WIRE AWG16 white	VG95218T020A003	Tinned copper, jacket PVF modified
WIRE AWG6 white	M22759/16 6-9	Tinned copper, jacket PVDF
WIRE AWG6 blue	M22759/16 6-6	Tinned copper, jacket PVDF
WIRE AWG6 green yellow	M22759/16 6-4/5	Tinned copper, jacket PVDF
Fillers	-	PTFE
Braid	TB13-T-200	TINNED copper
Heatshrink	DR25 1-0M (VG95343 Part 5 Type D)	Elastomer
Size 23	PN	Raw material
WIRE AWG16 white	VG95218T020A003	Tinned copper, jacket PVF modified
WIRE AWG4 white	M22759/34 4	Tinned copper, jacket ETFE
WIRE AWG4 blue	M22759/34 4	Tinned copper, jacket ETFE
WIRE AWG4 green yellow	M22759/34 4	Tinned copper, jacket PVDF
Fillers	-	PTFE
Braid	TB13-T-200	Tinned copper
Heatshrink	DR25 1-0M (VG95343 Part 5 Type D)	Elastomer
Size 25	PN	Raw material
WIRE AWG16 white	VG95218T020A003	Tinned copper, jacket PVF modified
WIRE AWG6 white	M22759/16 6-9	Tinned copper, jacket PVDF
WIRE AWG6 blue	M22759/16 6-6	Tinned copper, jacket PVDF
WIRE AWG6 green yellow	M22759/16 6-4/5	Tinned copper, jacket PVDF
Fillers	-	PTFE
Braid	TB13-T-200	Tinned copper
Heatshrink	DR25 1-0M (VG95343 Part 5 Type D)	Elastomer

All dimensions are given for information only and are in mm, except as otherwise specified | *in mm: 1mm=0.03937 inch

Series III TV-CTV
Series II JT
Series I LJT
Accessories & tools
Assembly instructions

MIL-DTL-38999 SERIES III DERIVED RANGE - POWERSAFE - VG96944

Size 13	PN	Raw material
WIRE AWG20	M22759/34 20	Tinned copper, jacket ETFE
WIRE AWG14	M22759/34 14	Tinned copper, jacket ETFE
Fillers	/	PTFE
Braid	4D045558	Nickel copper
Heatshrink	RW200E-1/2-0 or HLR33001270	Fluroelastomeric or Viton
Size 15	PN	Raw material
WIRE AWG16	M22759/34 16	Tinned copper, jacket ETFE
WIRE AWG12	M22759/34 12	Tinned copper, jacket ETFE
Fillers	/	PTFE
Braid	4D047547	Nickel copper
Heatshrink	RW200E-3/4-0 or HLR33001900	Fluroelastomeric or Viton
Size 17	PN	Raw material
WIRE AWG16	M22759/34 16	Tinned copper, jacket ETFE
WIRE AWG12	M22759/34 12	Tinned copper, jacket ETFE
Fillers	/	PTFE
Braid	4D047547	Nickel copper
Heatshrink	RW200E-3/4-0 or HLR33001900	Fluroelastomeric or Viton
Size 21	PN	Raw material
WIRE AWG16	M22759/34 16	Tinned copper, jacket ETFE
WIRE AWG6	M22759/34 6	Tinned copper, jacket ETFE
Fillers	/	PTFE
Braid	4D045591	Nickel copper
Heatshrink	RW200E-1 1/2-0 or HLR33003810	Fluroelastomeric or Viton
Size 23	PN	Raw material
WIRE AWG16	M22759/34 16	Tinned copper, jacket ETFE
WIRE AWG4	M22759/34 4	Tinned copper, jacket ETFE
Fillers	/	PTFE
Braid	4D045591	Nickel copper
Heatshrink	RW200E-1 1/2-0 or HLR33003810	Fluroelastomeric or Viton
Size 25	PN	Raw material
WIRE AWG16	M22759/34 16	Tinned copper, jacket ETFE
WIRE AWG6	M22759/34 6	Tinned copper, jacket ETFE
Fillers	/	PTFE
Braid	4D045591	Nickel copper
Heatshrink	RW200E-1 1/2-0 or HLR33003810	Fluroelastomeric or Viton

Note that High performance Nickel plated or Silver plated wires can also be used for harsh environment applications, to withstand higher temperatures.

All dimensions are given for information only and are in mm, except as otherwise specified | *in mm: 1mm=0.03937 inch

Due to technical modifications, all information provided is subject to change without prior notice
Designed by Amphenol Socapex

Amphenol SOCAPEX

MIL-DTL-38999 SERIES III DERIVED RANGE - RNJLP - RACK & PANEL LOW PROFILE

Low Profile Rack and Panel connector for blind mate connections.



Description

Rack and panel range using MIL-DTL-38999 Series III inserts. Realignment capabilities & floatability on 3 axis. Connection between a rack (moving unit) and a panel (fixed structure) without manually coupling/uncoupling the connectors. Low profile version for reduced distance between the racks: 7.3mm panel to rack distance (Square flange) or 16mm (Jam nut) instead of 36mm with standard RNJ / HE308.

Main features

EASY TO USE

- Push to mate, easy and fast connection.
- Locking to be ensured by mechanical device on the rack.

AXIAL, ANGULAR AND LONGITUDINAL FLOATABILITY

OPTIMIZED DESIGN

- Low profile: shorter distance between panels (same than ARINC404).
- Light weight: 20% weight savings versus standard RNJ (plug) for square flange.
- Sealing:
 - Plug rear membrane protected by a metal cap on plug.
 - O-ring gasket on receptacle and plug for sealing.
 - Interfacial seal on male insert.

EMI/EMP SHIELDING

- Grounding fingers ensuring shielding before contact mating.

MATERIAL

- Aluminum with Olive drab cadmium, Nickel or Black zinc nickel plating
- Stainless steel Passivated

38999 SERIES III ARRANGEMENTS AND CONTACTS

- Available with high-density inserts ^{HD}
- Shells size from 11 to 25.
- Rear accessory possibility compatible with MIL-DTL-38999 Series III backshells.
- Same tools than MIL-DTL-38999 Series III.

OPTIONS

- Crimp or PC tail terminations
- Jam nut or Square flange: [RNJLP2***/RNJLP4***](#) or [RNJLP6***/RNJLP8***](#).
- Stand-off option on receptacles [RNJLP27***F459](#) & [RNJLP67***F459](#).

Plug concept

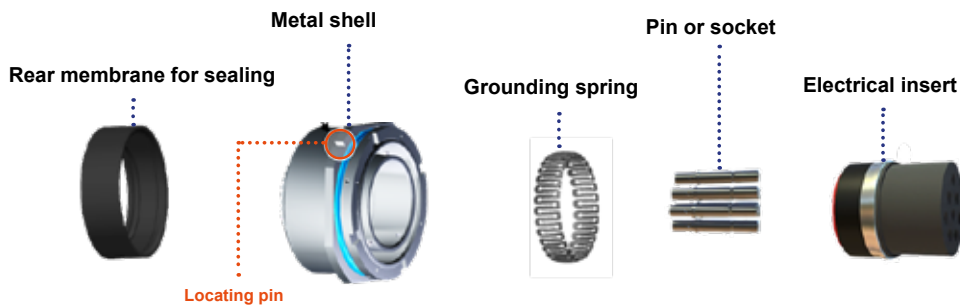

Options

		JAM NUT	SQUARE FLANGE
Plug RNJLP*6	Crimp	RNJLP26** 	RNJLP66**
	PCB (flex applications)	RNJLP46*1* without rear thread - dedicated to PCB contacts	RNJLP86*1* without rear thread - dedicated to PCB contacts
Receptacle RNJLP*7	Crimp	RNJLP27** 	RNJLP67**
	PCB	RNJLP27*1* without rear thread - dedicated to PCB contacts	RNJLP67*1* without rear thread - dedicated to PCB contacts
		RNJLP27*1*F459 Stand-off 	

^{HD} High density 38999.

Series III TV-CTV
Series II JT
Series I LJT
Accessories & tools
Assembly instructions

MIL-DTL-38999 SERIES III DERIVED RANGE - HOW TO ORDER RNJLP

Amphenol Designations - RNJLP Crimp connectors

Series	1. Shell type	2. Crimp contacts	3. Contacts arrangement	4. Contact gender	5. Keying	6. Material and platings	7. With or without contacts
RNJLP	26	T	15-35	S	N	014	LC

1. Shell type

Code	Shell type	Description
27	Receptacle	Jam-nut receptacle
67		Square flange receptacle
26	Plug	Jam-nut plug
66		Square flange plug

2. Crimp contacts

T	Aluminum shells
KE	Stainless steel shells (303)

For Stainless steel 316L, please consult us.

3. Contacts arrangements

Refer to page 18 for contact arrangements
First number represents the shell size and second number is the contact arrangement

4. Contact gender

P	Pin (500 cycles)
S	Socket (500 cycles)

5. Keying

N	For other coding possibilities, please consult us
(for normal)	

6. Material and platings

Code	Shell material	Shell finish
014	Aluminum	Olive drab cadmium
023		Nickel ✓
033K		Black zinc nickel ✓
078		Black Zinc Nickel without CrVI ✓
076		Tin Zinc ✓
Blank	Stainless steel	Passivated ✓

For other materials/platings, please consult us.

7. With or without contacts

076	Tin Zinc ✓
Blank	Connector delivered with contacts
LC	Connector delivered without contacts

Amphenol Designations - RNJLP PCB connectors

Series	1. Shell type	2. PC Tail contacts	3. Contacts arrangement	4. Contact gender	5. Keying	6. Material and platings	7. Deviation
RNJLP	46	CI	15-35	P	N	033K	-

1. Shell type

Code	Shell type	Description
27	Receptacle	Jam-nut receptacle
67		Square flange receptacle
46	Plug	Jam-nut plug without rear accessory possibility
86		Square flange plug without rear accessory possibility

2. PC Tail contacts

Code	Shell plating	Description
CI	Aluminum	Standard length
LI		Long length
KECI	Stainless steel (303)	Standard length
KELI		Long length

For Stainless steel 316L, please consult us.

3. Contacts arrangements

Refer to page 18 for contact arrangements
First number represents the shell size and second number is the contact arrangement

4. Contact gender

P	Pin (500 cycles)
S	Socket (500 cycles)

Connectors with PC Tail contacts are always delivered with contacts.

5. Keying

N	For other coding possibilities, please consult us
(for normal)	

6. Material and platings

Code	Shell material	Shell finish
014	Aluminum	Olive drab cadmium
023		Nickel ✓
033K		Black zinc nickel ✓
076		Tin Zinc ✓
078		Black Zinc Nickel without CrVI ✓
Blank	Stainless steel	Passivated ✓

For other materials/platings, please consult us.

7. Deviation

Shell style	PC Tail finish / Tinning				Shell type compatibility
	Tin lead	Silver tin	Silver tin copper	Gold	
Standard	F404	F404LF	F404LFC	Blank	All
Stand-off *	F459	F459LF	F459LFC	F459H	27 / 67

* For receptacles only, for plugs consult us.
For other deviations, please consult us.

✓ RoHS compliant

All dimensions are given for information only and are in mm, except as otherwise specified | *in mm: 1mm=0.03937 inch

MIL-DTL-38999 SERIES III DERIVED RANGE - RNJLP - RACK & PANEL LOW PROFILE

Floating and realignment features

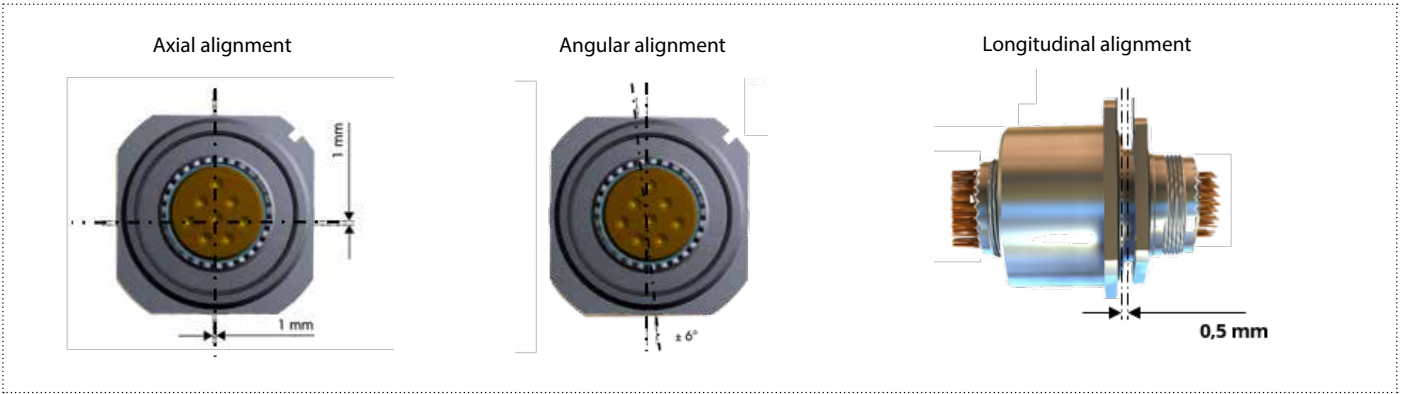

Environmental characteristics

	RNJLP
Temperature range	-65°C to +175°C for Olive drab cadmium, Black zinc nickel & Tin Zinc plating -65°C to +200°C for Nickel plating and Stainless steel
Shell corrosion resistance : Salt spray	Olive drab cadmium : 500h Tin Zinc: 500h Nickel : 48h Black zinc nickel, consult us Passivated Stainless steel : 500h

Panel integration

- Mandatory distance to guarantee the product performances.
- Guiding system: the system must ensure the right positioning of the rack independently of the connectors.
- No mechanical stress must be applied to the rear of the plug (wires or flex).

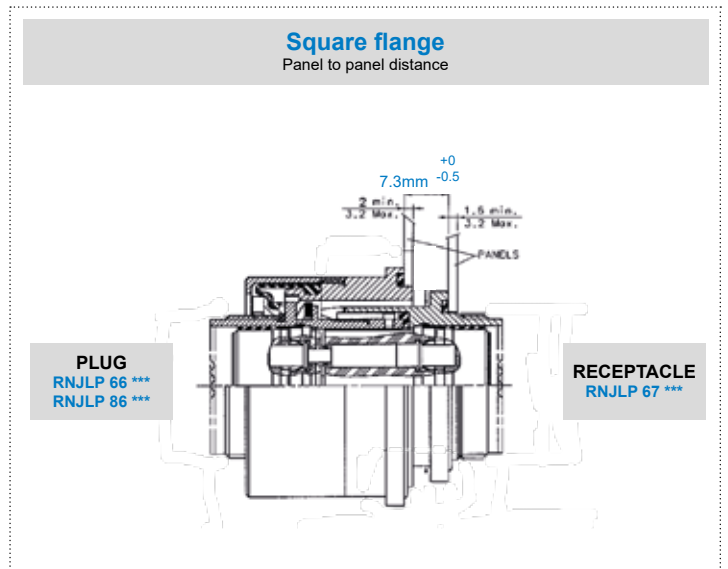
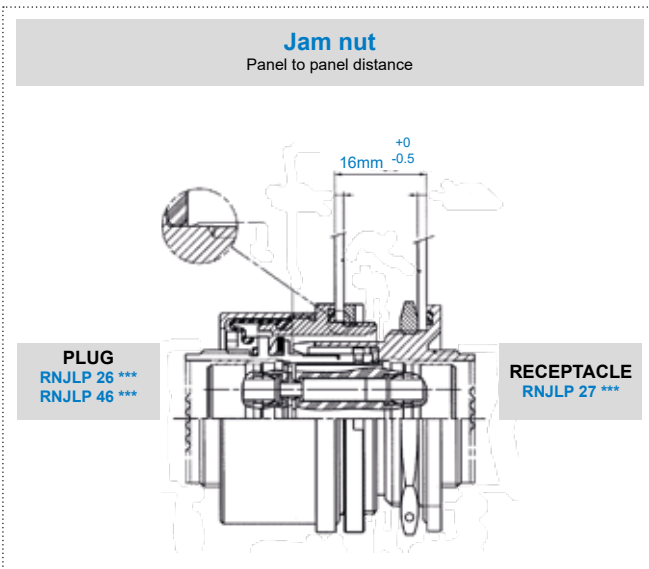

Panel mounting direction

	Plug		Receptacle		
	Jam nut RNJLP26/46	Square flange RNJLP66/86	Jam nut standard RNJLP27	Jam nut stand-off RNJLP27***F459	Square flange RNJLP67
Back panel mounting			✓		
Front panel mounting					✓

All dimensions are given for information only and are in mm, except as otherwise specified | *in mm: 1mm=0.03937 inch

Series III TV-CTV
Series II JT
Series I LJT
Accessories & tools
Assembly instructions

MIL-DTL-38999 SERIES III DERIVED RANGE - RNJLP - RACK & PANEL LOW PROFILE

Overall dimensions Square flange receptacle

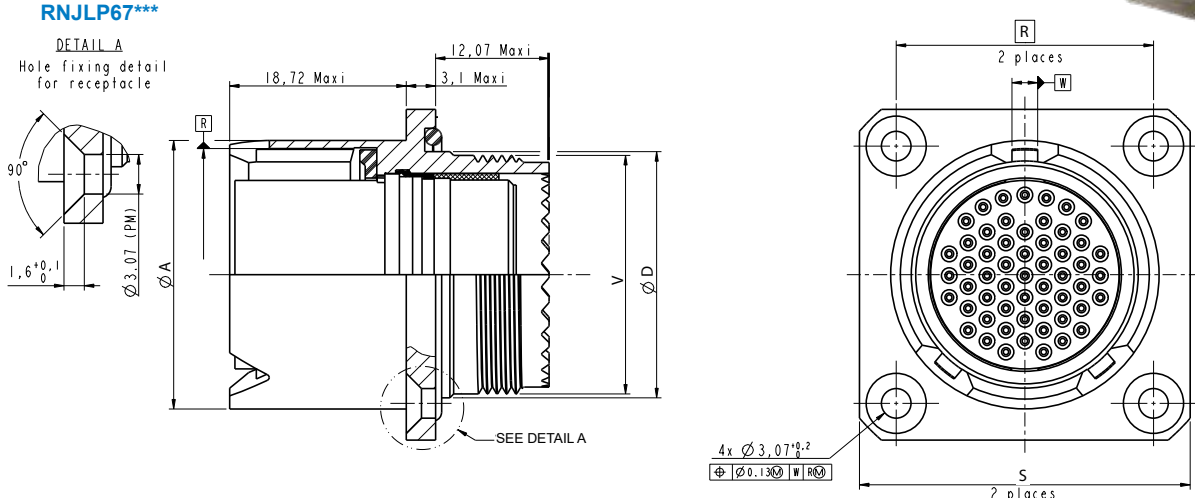

Size	ØD +0 -0.05	V thread-metric	ØA_{Max}	S +0 -0.3	R
11	16.73	M15x1-6g	18.68	28.3	20.62
13	19.93	M18x1-6g	21.88	30.7	23.01
15	22.83	M22x1-6g	25.08	32.3	24.61
17	25.83	M25x1-6g	28.18	34.7	26.97
19	29.03	M28x1-6g	31.18	37.1	29.36
21	32.23	M31x1-6g	34.38	39.7	31.75
23	34.03	M34x1-6g	37.58	42.9	34.93
25	37.23	M37x1-6g	40.78	46	38.10

Jam nut receptacle

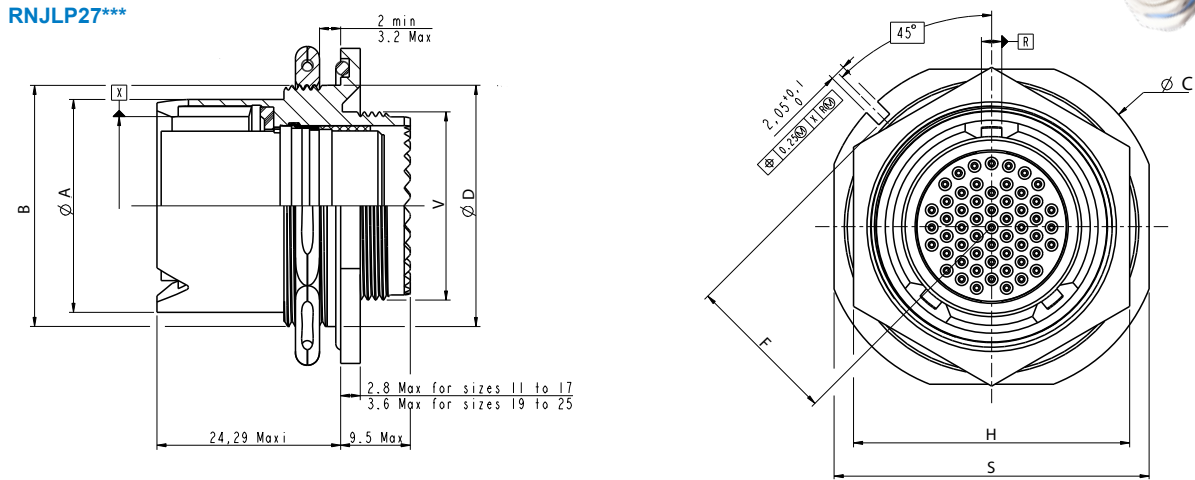

Size	V thread-metric	ØA_{Max}	B thread-metric	S +0 -0.4	H _{Max}	F +0 -0.2	ØC +0 -0.4	ØD +0 -0.05
11	M15x1-6g	18.68	M20x1-6g	32.16	25.84	15.33	35.34	20.83
13	M18x1-6g	21.88	M25x1-6g	35.34	30.62	16.92	38.51	25.53
15	M22x1-6g	25.08	M28x1-6g	38.51	33.76	18.51	41.69	28.75
17	M25x1-6g	28.18	M32x1-6g	41.69	36.97	20.10	44.86	31.93
19	M28x1-6g	31.18	M35x1-6g	46.43	40.11	22.67	49.64	35.10
21	M31x1-6g	34.38	M38x1-6g	49.64	43.32	24.26	52.78	38.23
23	M34x1-6g	37.58	M41x1-6g	52.78	46.46	25.84	55.99	41.45
25	M37x1-6g	40.78	M44x1-6g	55.99	51.24	27.43	59.13	44.63

All dimensions are given for information only and are in mm, except as otherwise specified | *in mm: 1mm=0.03937 inch

Due to technical modifications, all information provided is subject to change without prior notice
Designed by Amphenol Socapex

MIL-DTL-38999 SERIES III DERIVED RANGE - RNJLP - RACK & PANEL LOW PROFILE

Stand-off Jam nut receptacle

RNJLP27*I*F459**

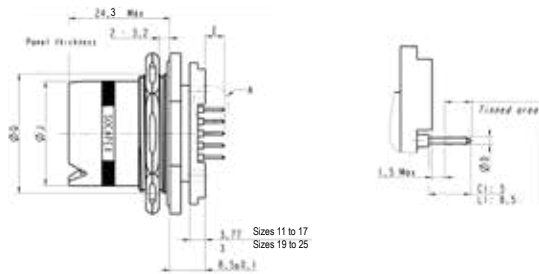

Size	ØJ _{Max}	ØQ _{+0 -0.05}
11	18.68	20.83
13	21.88	25.53
15	25.08	28.75
17	28.18	31.93
19	31.18	35.10
21	34.38	38.23
23	37.58	41.45
25	40.78	44.63

Contact length	Contact size			
	22D	20	16	12
CI	Socket: 3.99 – 5.07 Pin: 4.19 – 5.27			
ØD _{MAX} Tinned termination	0.6	0.8	1.25	1.8
LI	Socket: 7.49 – 8.57 Pin: 7.69 – 8.77			
ØD _{MAX} Tinned termination	0.8	0.8	1.25	1.8

PCB mounting

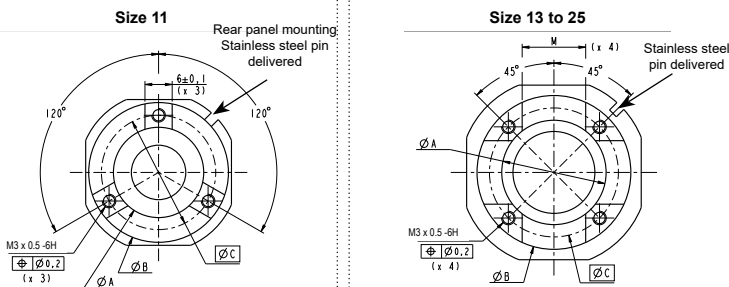

Size	ØA ± 0.15	ØB ± 0.15	ØC	M _{+0.2 0}
11	19.9	30.8	25.20	-
13	19.9	30.8	25.25	12
15	23	33.9	28.42	14
17	26	36.8	31.42	16
19	29.5	40.4	35.03	18
21	32.2	43.2	37.82	20
23	35.5	46.5	41.12	23
25	38.6	49.6	44.3	25

All dimensions are given for information only and are in mm, except as otherwise specified | *in mm: 1mm=0.03937 inch

Due to technical modifications, all information provided is subject to change without prior notice
Designed by Amphenol Socapex

MIL-DTL-38999 SERIES III DERIVED RANGE - RNJLP - RACK & PANEL LOW PROFILE

Accessory interface conform to MIL-DTL-38999 Series III. A locating pin is provided to ensure proper positioning of the connector. Available without rear thread for PC Tails applications (on flex) contacts (CI or LI) : RNJLP66 or RNJLP86.

Square flange plug



RNJLP66***

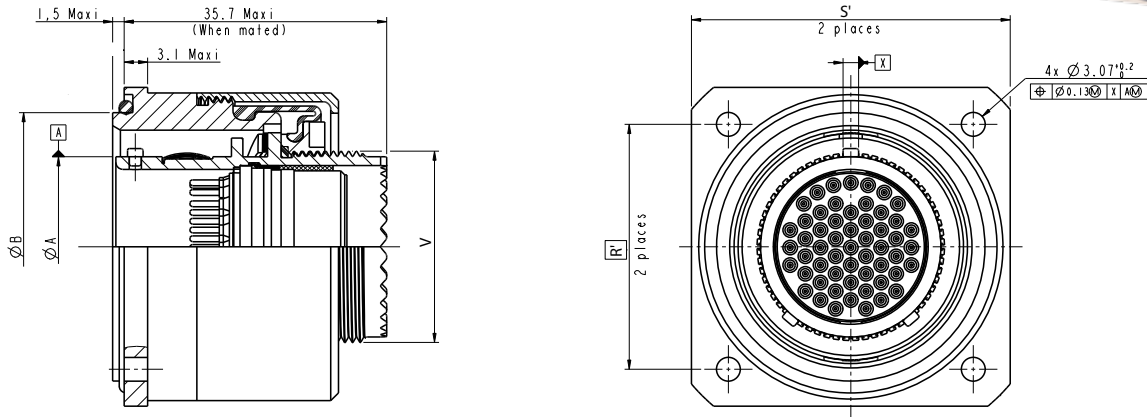

Size	$\begin{matrix} +0 \\ \text{ØA} \\ -0.13 \end{matrix}$	$\begin{matrix} +0 \\ \text{ØB} \\ -0.05 \end{matrix}$	V thread-metric	$\begin{matrix} +0 \\ \text{S}' \\ -0.25 \end{matrix}$	R'
11	14.38	25.53	M15x1-6g	33.60	25.5
13	17.23	28.75	M18x1-6g	36.30	28
15	20.40	31.93	M22x1-6g	39.50	30
17	23.58	35.10	M25x1-6g	41.69	32
19	26.24	38.23	M28x1-6g	46.43	35
21	29.42	41.45	M31x1-6g	49.64	37
23	32.59	44.63	M34x1-6g	53.00	39.5
25	35.77	48.03	M37x1-6g	54.50	41.5

Jam nut plug



RNJLP26***

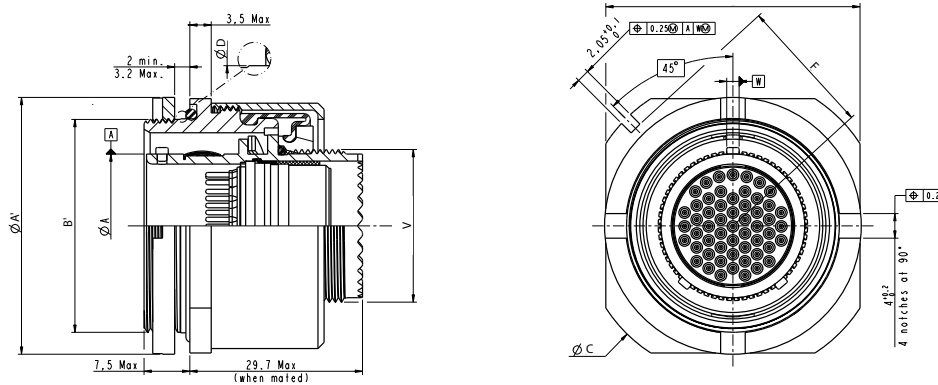

Size	$\begin{matrix} +0 \\ \text{ØA} \\ -0.13 \end{matrix}$	B' thread-metric	$\begin{matrix} +0 \\ \text{ØD} \\ -0.05 \end{matrix}$	V thread-metric	$\begin{matrix} +0 \\ \text{ØS}' \\ -0.25 \end{matrix}$	$\begin{matrix} +0 \\ \text{ØC} \\ -0.4 \end{matrix}$	$\begin{matrix} +0 \\ \text{F} \\ -0.25 \end{matrix}$	$\begin{matrix} +0 \\ \text{ØA}' \\ -0.25 \end{matrix}$ Max
11	14.38	M25x1-6g	25.53	M15x1-6g	32.16	38.50	16.92	32.10
13	17.23	M28x1-6g	28.75	M18x1-6g	35.34	41.68	18.51	35.10
15	20.40	M32x1-6g	31.93	M22x1-6g	38.51	44.85	20.10	39.10
17	23.58	M35x1-6g	35.10	M25x1-6g	41.69	49.63	22.67	42.10
19	26.24	M38x1-6g	38.23	M28x1-6g	46.43	52.78	24.26	45.70
21	29.42	M41x1-6g	41.45	M31x1-6g	49.64	55.99	25.84	48.70
23	32.59	M44x1-6g	44.63	M34x1-6g	52.78	59.13	27.43	51.70
25	35.77	M48x1-6g	48.03	M37x1-6g	55.93	59.53	27.58	55.70

All dimensions are given for information only and are in mm, except as otherwise specified | *in mm: 1mm=0.03937 inch

Due to technical modifications, all information provided is subject to change without prior notice
Designed by Amphenol Socapex

MIL-DTL-38999 SERIES III DERIVED RANGE - RNJLP - RACK & PANEL LOW PROFILE

Mated pair - PC-Tail versions

Fixing nuts with 4 slots for jam nut plug are available with 4 holes for lockwiring capability (optional).

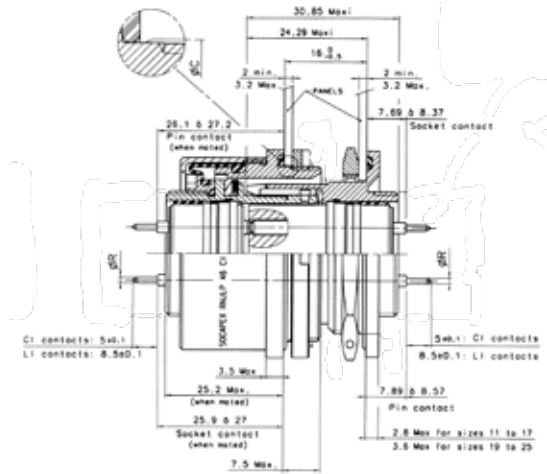

PLUG
RNJ LP46CI*
RNJ LP46LI**

RECEPTACLE
RNJ LP27CI*
RNJ LP27LI**

Other dimensions, please refer to crimp contacts drawing.

Contact diameter		Contact size			
		22D	20	16	12
CI	ØR _{MAX} gold termination	0.5	0.7	1.15	1.7
LI	ØR _{MAX} gold termination	0.7	0.7	1.15	1.7
CI	ØR _{MAX} tinned termination	0.6	0.8	1.25	1.8
LI	ØR _{MAX} tinned termination	0.8	0.8	1.25	1.8

Plug installation tool - Spanner for castle nut



Size	Amphenol
11	RNJ8982 A11
13	RNJ8982 B13
15	RNJ8982 C15
17	RNJ8982 D17
19	RNJ8982 E19
21	RNJ8982 F21
23	RNJ8982 G23
25	RNJ8982 H25

All dimensions are given for information only and are in mm, except as otherwise specified | *in mm: 1mm=0.03937 inch

Series III TV-CTV
Series II JT
Series I LJT
Accessories & tools
Assembly instructions

MIL-DTL-38999 SERIES III DERIVED RANGE - RNJLP - RACK & PANEL LOW PROFILE

Panel hole dimensions

A stainless steel pin is always provided to ensure a perfect positioning of the connector on the panel.

Square Flange receptacle - RNJLP67**

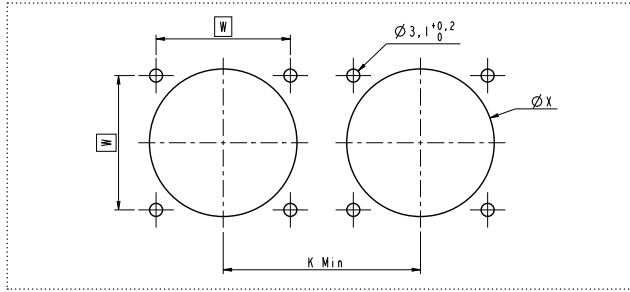

Size	K_{MIN}	W	ϕX $\begin{matrix} +0.1 \\ 0 \end{matrix}$
11	36.0	20.62	16.78
13	39.6	23.01	19.98
15	43.3	24.61	22.88
17	47.0	26.97	25.88
19	50.6	29.39	29.08
21	54.2	31.75	32.28
23	59.7	34.93	34.08
25	59.7	38.10	37.28

Jam nut receptacle - RNJLP27**

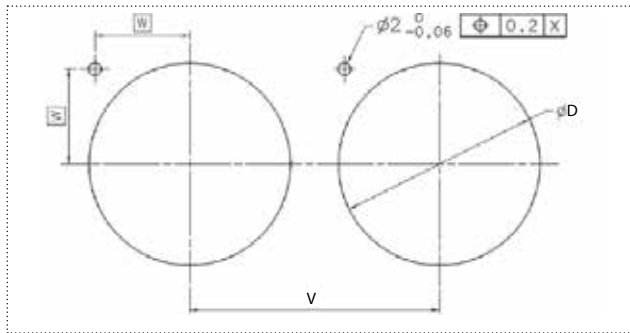

Size	Receptacle		
	V_{MIN}	W	ϕD $\begin{matrix} +0.1 \\ 0 \end{matrix}$
11	32.57	11.69	20.86
13	36	12.81	25.58
15	39.6	13.94	28.80
17	43.3	15.06	31.98
19	47	16.88	35.15
21	50.6	18	38.28
23	54.2	19.12	41.50
25	59.7	20.24	44.68

Square Flange plug - RNJLP66**

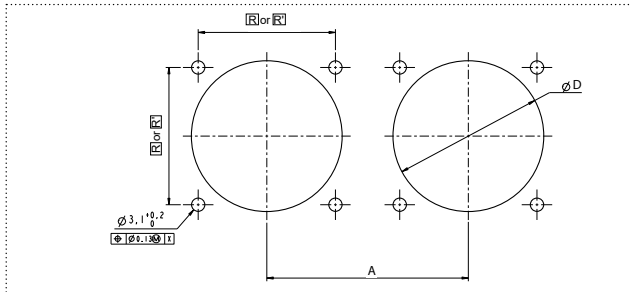

Size	Plug		
	V_{MIN}	W	ϕD $\begin{matrix} +0.1 \\ 0 \end{matrix}$
11	36	25.5	25.58
13	39.6	28	28.80
15	43.3	30	31.98
17	47	32	35.15
19	50.6	35	38.28
21	54.2	37	41.50
23	59.7	39.5	44.68
25	59.7	41.5	48.08

Jam nut plug - RNJLP26**

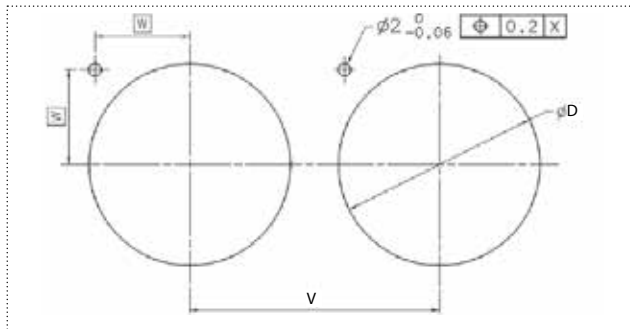

Size	Plug		
	V_{MIN}	W	ϕD $\begin{matrix} +0.1 \\ 0 \end{matrix}$
11	32.57	12.81	25.58
13	36	13.94	28.80
15	39.6	15.06	31.98
17	43.3	16.88	35.15
19	47	18	38.28
21	50.6	19.12	41.50
23	54.2	20.24	44.68
25	59.7	20.30	48.08

All dimensions are given for information only and are in mm, except as otherwise specified | *in mm: 1mm=0.03937 inch

Due to technical modifications, all information provided is subject to change without prior notice
Designed by Amphenol Socapex

MIL-DTL-38999 SERIES III DERIVED RANGE - SC39 - QUICK DISCONNECT

Quick disconnection solution with lanyard possibilities.

Description

Quick disconnect range derived from MIL-DTL-38999 Series III. Instant decoupling and damage free separation with a direct pull on the lanyard/harness. Quick breakaway fail-safe unmating. Weight & space savings compare to others quick disconnect solutions on the market.



Main features

QUICK-EASY INSTALLATION & EMERGENCY DISCONNECT CONNECTOR. NO COUPLING NUT, NO THREADING.

CONTACT PROTECTIVE SCOOP-PROOF SHELL

- Interfacial seal ensuring sealing around each contact.
- Durability ≥ 1500 cycles, with suitable contacts.

MATERIAL

- Shell: Aluminum and Stainless steel
- Plating: Olive drab cadmium, Nickel, Passivation (Stainless steel).

SHELLS

Straight plug and Square flange, Jam nut, or in-line receptacle. Size 09 to 17. Upper sizes available on request.

38999 SERIES III CONTACTS ARRANGEMENTS.

COUPLING SPRING: Dual action on receptacle for mechanical retention, with different forces options:

- Standard version: from 50 to 100N.
- Low force separation capabilities: less than 50N. **SC39****L**

OPTIONS

- Lanyard release: **SC39RL*****
- Integrated backshell: **SC39***F472**
- Stand-off for printed circuit board: **SC39***F459**

Lanyard release plug
SC39RL*06**

Jam nut receptacle
SC39*07**



Lanyard characteristics

Axial pull of lanyard: 10° max misalignment

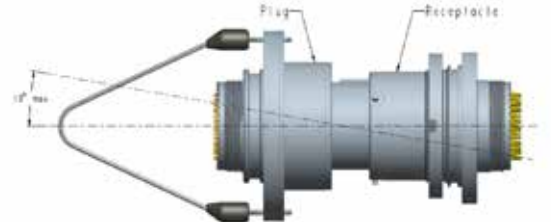

Straight plug
SC39*06**



Square flange receptacle
SC39P*00**



In-line receptacle
SC39*01**



Lanyard In-line receptacle
SC39RL*01**



Integrated backshell
SC39*F472**



Low force separation capabilities

SC39***L

- Low force coupling spring on receptacle.
- Forces exclude contact insertion/extraction forces.
- Forces can be customized upon request.

Size	SC39 STANDARD		SC39 LOW FORCE	
	Mating force (kg)	Unmating force (kg)	Mating force (kg)	Unmating force (kg)
9	1.2	5	2.2	4.1
11	2.2	7.6	2.2	4.1
13	2.05	8.8	2.6	4.7
15	2.45	9.1	2.3	4.1

Series III TV-CTV
Series II JT
Series I LJT
Accessories & tools
Assembly instructions

MIL-DTL-38999 SERIES III DERIVED RANGE - HOW TO ORDER SC39

Amphenol Designations - SC39 Crimp connectors

	1.	2.	3.	4.	5.	6.	7.	8.	9.	10.
Series	Shell type	Low force option	Crimp contacts	Ground plane and Quadrax	Material and platings	Insert arrangement	Contact gender	Keying	With or without contacts	Deviation
SC39	06	-	R	-	W	15-35	P	A	-	F472

1. Shell type

Shell type	Associated materials and platings	Temperature
06	W	+175°C
S06*	F, K	+200°C*
RL06	W	+175°C
RLS06*	F, K	+200°C*
P00	W	+175°C
PS00*	F, K	+200°C*
07	W	+175°C
S07*	F, K	+200°C*
01	W	+175°C
S01*	F, K	+200°C*
RL01	W	+175°C
RLS01*	F, K	+200°C*

* «S» Stand for 200°C compatibility. Omit for High-density inserts Ⓞ, inserts with Quadrax contacts and differential Twinax contacts Ⓞ are +175°C maxi compatible.

2. Low force option (receptacle only)

Blank	Standard versions
L	Low force version - Consult us to confirm availability

For other version, please consult us

3. Crimp contacts

R	Crimp contact
---	---------------

4. Conductive inserts & inserts for Quadrax and differential Twinax contacts (optional)

Conductive inserts are available for Aluminum versions with Olive Drab Cadmium and Nickel. For any others materials and platings please consult us.

Blank	For standard inserts without ground plane and indexation key.
G	Ⓞ Ground Plane version - Conductive insert. Mandatory for 09-05*.
Q	Ⓞ Inserts designed with an indexation key to avoid contacts rotation in the cavities when using a keyed contact - Size 8 contacts only.
GQ	ⓄⓄ Ground plane version with insert designed with an indexation key.

* Please note that 09-05 insert is automatically conductive. Add the 'G' letter in all your references for this arrangement.

5. Material and platings

Shell material	Shell finish
W	Olive drab cadmium
F	Nickel ✓
K	Passivated ✓

6. Contacts arrangements

Refer to page 18 for contact arrangements
First number represents the shell size and second number is the contact arrangement

7. Contact gender

P	Pin (500 cycles)
S	Socket (500 cycles)

8. Keying

Blank (for normal)	A	B	C	D	E
--------------------	---	---	---	---	---

9. With or without contacts

Blank	Connector delivered with contacts
LC	Connector delivered without contacts

10. Deviation

Deviation	Description	Shell type compatibility
F472	Integrated backshell	All

For other deviations, please consult us

All dimensions are given for information only and are in mm, except as otherwise specified | *in mm: 1mm=0.03937 inch

Due to technical modifications, all information provided is subject to change without prior notice
Designed by Amphenol Socapex



MIL-DTL-38999 SERIES III DERIVED RANGE - HOW TO ORDER SC39

Amphenol Designations - SC39 PCB Receptacles

	1.	2.	3.	4.	5.	6.	7.	8.	9.
Series	Shell type	Low force option	Ground plane and Quadrax	Material and platings	PC Tail contacts	Insert arrangement	Contact gender	Keying	Deviation
SC39	07	-	-	W	CI	15-35	P	A	F459

1. Shell type

	Shell type	Associated materials and platings	Temperature
P00	Square flange receptacles	W	+175°C
PS00*		F, K, S, B	+200°C*
07	Jam nut receptacles	W	+175°C
S07*		F, K, S, B	+200°C*



* «S» Stand for 200°C compatibility. Omit for High-density inserts , inserts with Quadrax contacts and differential Twinax contacts  are +175°C maxi compatible.

2. Low force option

Blank	For standard versions
L	Low force version - Consult us to confirm availability

3. Conductive inserts & inserts for Quadrax and differential Twinax contacts (optional)

Conductive inserts are available for Aluminum versions with Olive Drab Cadmium and Nickel. For any others materials and platings please consult us.

Blank	For standard inserts without ground plane and indexation key.
G	 Ground Plane version - Conductive insert. Mandatory for 09-05*.
Q	 Inserts designed with an indexation key to avoid contacts rotation in the cavities when using a keyed contact - Size 8 contacts only.
GQ	 Ground plane version with insert designed with an indexation key.

* Please note that 09-05 insert is automatically conductive. Add the 'G' letter in all your references for this arrangement.

4. Material and platings

	Shell material	Shell finish
W	Aluminum	Olive drab cadmium
F		Nickel ✓
K	Stainless steel	Passivated ✓

5. PC Tail contacts

CI	Standard length
LI	Long length
SI	Short length(onlyfor size 22D contacts)

6. Insert arrangements

Refer to page 18 for contact arrangements
First number represents the shell size and second number is the contact arrangement

7. Contact gender

P	Pin (500 cycles)
S	Socket (500 cycles)

Connectors with PC Tail contacts are always delivered with contacts.

8. Keying

Blank (for normal)	A	B	C	D	E
--------------------	---	---	---	---	---

9. Deviation

Shell style	PC Tail finish / Tinning				Shell type compatibility
	Tin lead	Silver tin	Silver tin copper	Gold	
Standard	F404	F404LF ✓	F404LFC ✓	Blank ✓	All
Stand-off	F459	F459LF ✓	F459LFC ✓	F459H ✓	All

For other deviations, please consult us.

All dimensions are given for information only and are in mm, except as otherwise specified | *in mm: 1mm=0.03937 inch

Due to technical modifications, all information provided is subject to change without prior notice
Designed by Amphenol Socapex

Series III TV-CTV
Series II JT
Series I LJT
Accessories & tools
Assembly instructions

MIL-DTL-38999 SERIES III DERIVED RANGE - SC39 - QUICK DISCONNECT

Leakage attenuation

Frequency (MHz)	Leakage attenuation minimum (dB)	
	38999 Requirements	SC39
100	90	100
200	88	95
300	88	94
400	87	94
800	85	84
1000	85	74

Overall dimensions

Available with most common MIL-DTL-38999 Series III inserts.
Available from size 09 to 17, bigger sizes (19 to 25) upon request.

Square flange receptacle

SC39P*00***

Size	Thread V	S±0.3	R1	R2	ØB ± 0.1	ØGG ± 0.2
09	M12x1- 6g,R0.1	23.8	18.26	15.09	13.03	31.78
11	M15x1- 6g,R0.1	26.2	20.62	18.26	18.53	34.96
13	M18x1- 6g,R0.1	28.6	23.01	20.62	22.33	38.13
15	M22x1- 6g,R0.1	31.0	24.61	23.01	25.23	41.31
17	M25x1- 6g,R0.1	33.3	26.97	24.61	30.23	44.48

Stand-off Square flange receptacle

SC39*00IF459*****

Size	ØB ± 0.15	C ^{+0.2} ₀	ØJ ± 0.15	S ± 0.25	R2	ØGG ± 0.2
09	13.03	8	13.20	23.83	16.00	31.78
11	18.53	10	16.80	26.19	18.26	34.96
13	22.33	13	20.20	28.58	20.62	38.13
15	25.23	15	23.80	30.96	23.01	41.31
17	30.23	17	26.00	33.32	26.10	44.48

Contacts	CI - ØA		LI - ØE	
	Gold	Tinned	Gold	Tinned
T22D	0.5	0.6	0.7	0.8
T20	0.7	0.8	0.7	0.8
T16	1.15	1.25	1.15	1.25
T12	1.7	1.8	1.7	1.8

All dimensions are given for information only and are in mm, except as otherwise specified | *in mm: 1mm=0.03937 inch

Due to technical modifications, all information provided is subject to change without prior notice
Designed by Amphenol Socapex

MIL-DTL-38999 SERIES III DERIVED RANGE - SC39 - QUICK DISCONNECT

Jam nut receptacle

SC39*07***

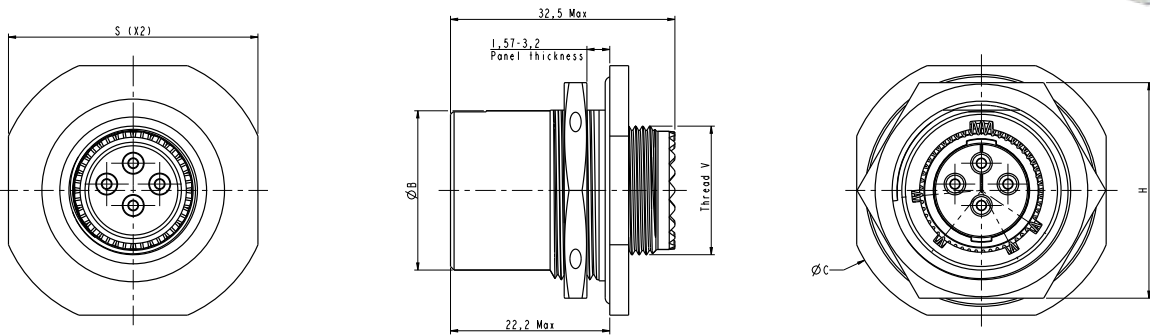

Size	ØB ± 0.1	S ± 0.3	Thread V	ØC ± 0.3	H ± 0.4
09	13.03	27.00	M12x1-6g.R0.1	30.2	22.26
11	18.53	31.78	M15x1-6g.R0.1	34.9	25.43
13	22.33	34.96	M18x1-6g.R0.1	38.10	30.21
15	25.23	38.13	M22x1-6g.R0.1	41.3	33.35
17	30.23	41.31	M22x1-6g.R0.1	44.5	36.56

Stand-off Jam nut receptacle

To avoid stress on contacts in PC-tail configurations

SC39*07***F459***

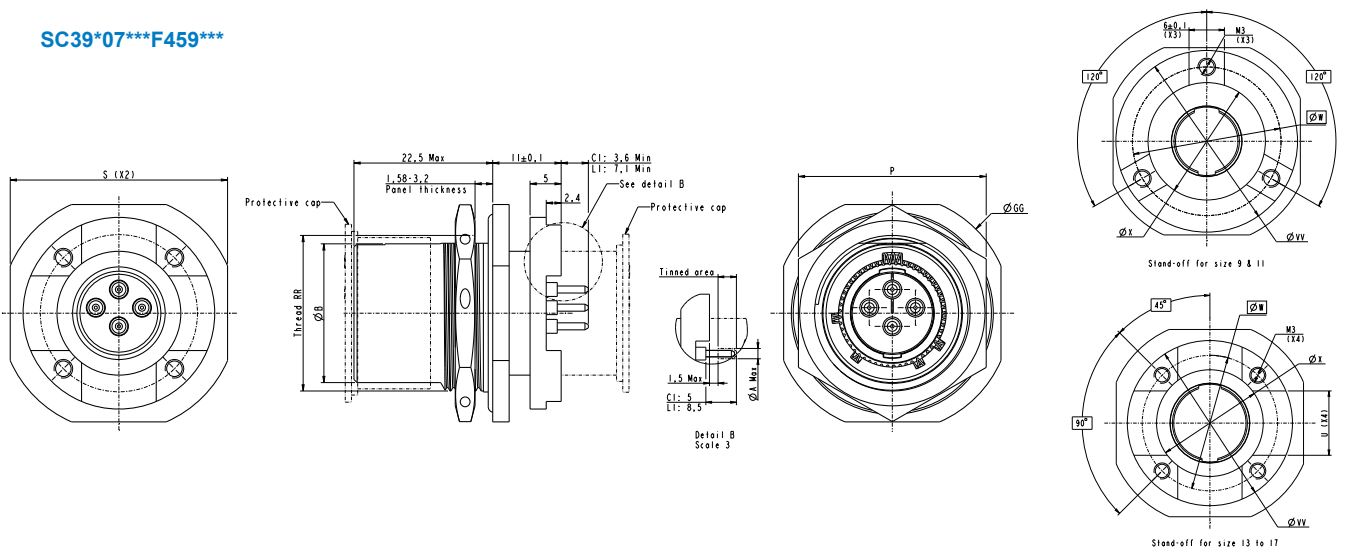

Size	ØB ± 0.15	ØP ± 0.4	S	C ^{+0.2/0}	ØW	X ± 0.15	ØGG	Thread RR	ØVV ± 0.15	Contacts	CI - ØA		LI - ØE	
											Gold	Tinned	Gold	Tinned
09	13.03	22.26	27.00	-	20.50	15.10	30.21	M 17x1-6g R0.100	26.00	T22D	0.5	0.6	0.7	0.8
11	18.53	25.43	31.78	-	25.20	19.90	34.96	M 20x1-6g R0.100	30.80	T20	0.7	0.8	0.7	0.8
13	22.33	30.21	34.96	12	25.25	19.90	38.13	M 25x1-6g R0.100	30.80	T16	1.15	1.25	1.15	1.25
15	25.23	33.35	38.13	14	28.42	23.00	41.31	M 28x1-6g R0.100	33.90	T12	1.7	1.8	1.7	1.8
17	30.23	36.56	41.31	16	31.42	26.00	44.48	M 32x1-6g R0.100	36.80					

All dimensions are given for information only and are in mm, except as otherwise specified | *in mm: 1mm=0.03937 inch

Due to technical modifications, all information provided is subject to change without prior notice
Designed by Amphenol Socapex

Series III TV-CTV
Series II JT
Series I LJT
Accessories & tools
Assembly instructions

MIL-DTL-38999 SERIES III DERIVED RANGE - SC39 - QUICK DISCONNECT

In-line receptacle

SC39*01*R**

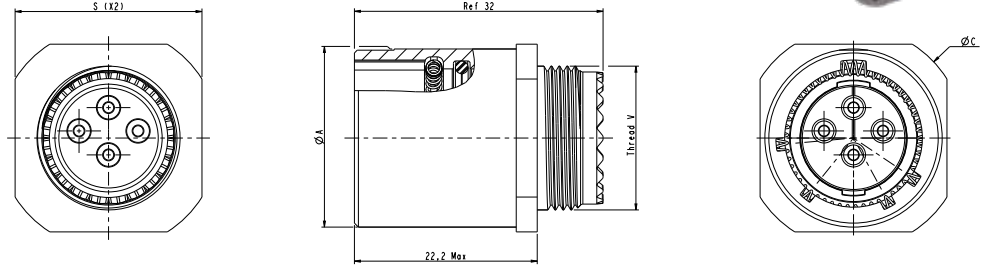

Size	ØA±0.1	ØC±0.25	Thread V	S ^{+0.23} / _{-0.25}
09	13.03	20.65	M 12x6g R0.100	17.18
11	18.53	23.02	M 15x6g R0.100	20.35
13	22.33	27.79	M 18x6g R0.100	23.53
15	25.23	30.99	M 22x6g R0.100	26.70
17	30.23	34.96	M 25x6g R0.100	31.48

In-line Receptacle with Integrated Backshell

SC39*01*R**F472

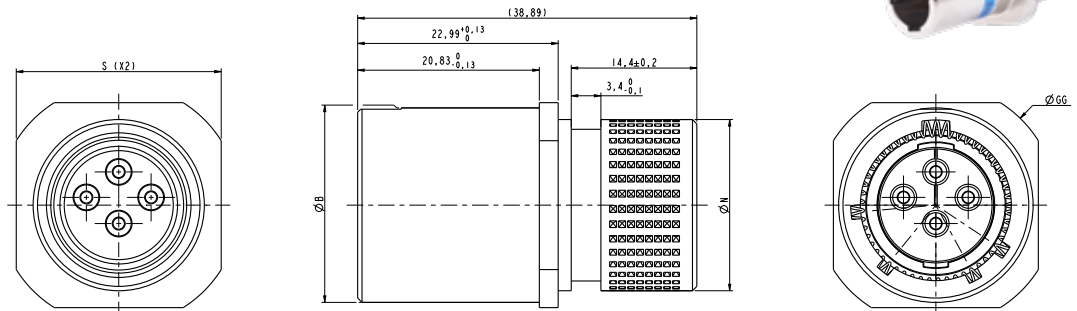

Size	ØB±0.1	ØN ⁺⁰ / _{-0.13}	S ^{+0.23} / _{-0.25}	ØGG±0.2
09	13.03	13.54	17.18	20.65
11	19.15	15.37	20.35	22.62
13	22.32	19.66	23.53	27.79
15	25.28	21.29	26.70	30.99
17	30.23	24.97	31.48	34.96

Lanyard In-line receptacle

SC39RL*01***

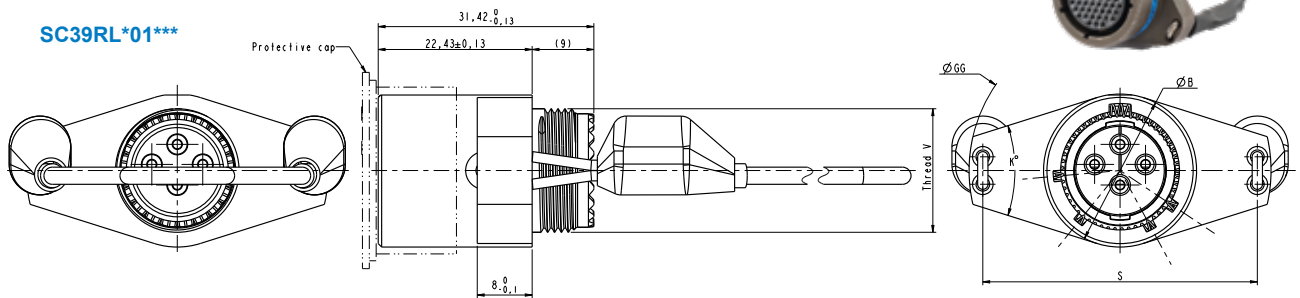

Size	ØB±0.1	K°±1°	S ^{+0.2} / ₀	ØGG±0.1	Thread V
09	13.03	15	32	36.03	M 12x6g R0.100
11	18.53	33	34	39.03	M 15x6g R0.100
13	22.33	35	40	44.03	M 18x6g R0.100
15	25.23	45	43	47.03	M 22x6g R0.100
17	30.23	45	46	50.03	M 25x6g R0.100

All dimensions are given for information only and are in mm, except as otherwise specified | *in mm: 1mm=0.03937 inch

Due to technical modifications, all information provided is subject to change without prior notice
Designed by Amphenol Socapex

MIL-DTL-38999 SERIES III DERIVED RANGE - SC39 - QUICK DISCONNECT

Straight plug

SC39*06***

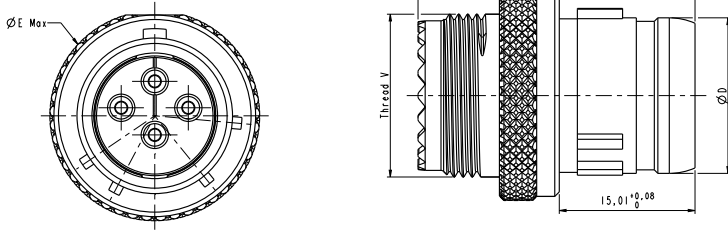

Size	$\varnothing E$ After Knurling	Thread V	$\varnothing D$ -0.13
09	14.13	M12x1-6g,R0.1	9.03
11	19.63	M15x1-6g,R0.1	14.38
13	23.43	M18x1-6g,R0.1	17.23
15	26.33	M22x1-6g,R0.1	20.40
17	31.33	M25x1-6g,R0.1	23.58

Straight plug with Integrated backshell

SC39*06***F472

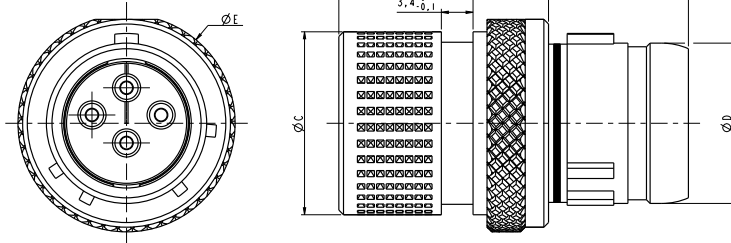

Size	$\varnothing C$ -0.13	$\varnothing D$ -0.13	$\varnothing E \pm 0.1$
09	12.53	9.03	14.03
11	15.37	14.38	19.53
13	19.66	17.23	23.33
15	21.29	20.40	26.23
17	24.46	23.58	31.23

Lanyard release plug

SC39RL*06***

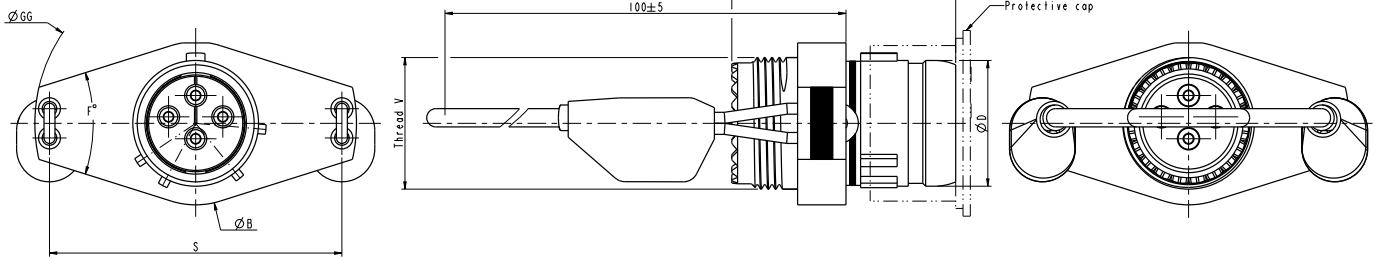

Size	$\varnothing B \pm 0.1$	$\varnothing D$ -0.13	$F^\circ \pm 1^\circ$	$\varnothing GG \pm 0.1$	$S_{-0}^{+0.2}$	Thread V
09	13.03	9.03	15	36.03	32	M12x1-6g,R0.1
11	18.53	14.38	33	39.03	34	M15x1-6g,R0.1
13	22.33	17.23	35	44.03	40	M18x1-6g,R0.1
15	25.23	20.40	45	47.03	43	M22x1-6g,R0.1
17	30.23	23.58	45	50.03	46	M25x1-6g,R0.1

All dimensions are given for information only and are in mm, except as otherwise specified | *in mm: 1mm=0.03937 inch

Due to technical modifications, all information provided is subject to change without prior notice
Designed by Amphenol Socapex

Series III TV-CTV
Series II JT
Series I LJT
Accessories & tools
Assembly instructions

MIL-DTL-38999 SERIES III DERIVED RANGE - SC39 - QUICK DISCONNECT

Panel hole dimensions

Rear panel mounting. Maximum panel thickness: 5.94mm.

Square flange Receptacle

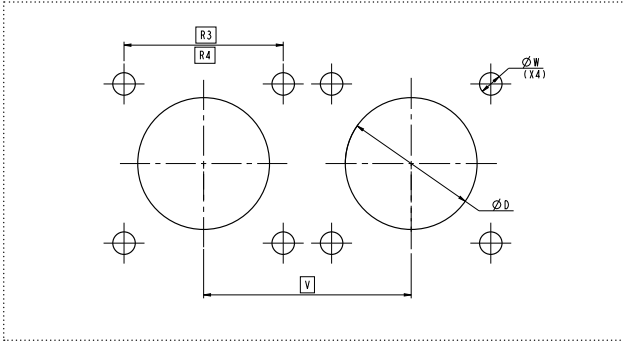

Size	R3	R4	V	ØW ⁺⁰ _{-0.25}	ØD _{min}
09	18.26	15.09	24.60	3.25	13.89
11	20.62	18.26	27.00	3.25	19.77
13	23.01	20.62	30.20	3.25	23.60
15	24.61	23.01	33.30	3.25	26.49
17	26.97	24.61	36.50	3.25	31.10

Jam nut Receptacle

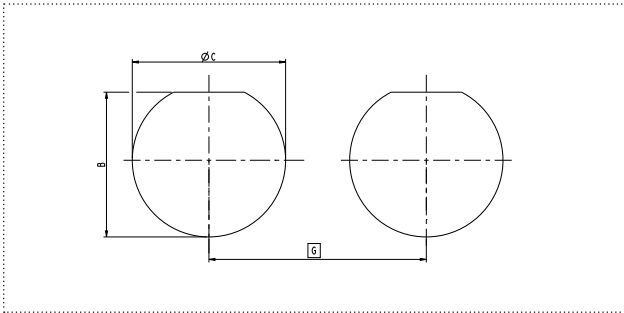

Size	G _{min}	ØC ^{+0.25} ₋₀	B ⁺⁰ _{-0.25}
09	27.80	17.60	16.70
11	32.60	20.96	19.59
13	36.00	25.65	24.26
15	39.60	28.83	27.56
17	43.30	32.01	30.73

All dimensions are given for information only and are in mm, except as otherwise specified | *in mm: 1mm=0.03937 inch

Due to technical modifications, all information provided is subject to change without prior notice
Designed by Amphenol Socapex

MIL-DTL-38999 SERIES III DERIVED RANGE - TV μ COM - 10GB+

10Gb/s Ethernet on a Size 11 MIL-DTL-38999 series III shell



Description

μ Com-Series is a new range of connectors designed to address the latest trends of the military industry: miniaturization and high speed. With the highest resistance for use in the harshest environments. TV μ Com combines μ Com-10G+ speed with a MIL-DTL-38999 Series III Size 11 shell robustness.

Main Features

- 10Gb+: exceeds 10Gb/s Ethernet following IEEE 802.3an-2006: 10GBase-T.
- Cat.6A connector according to TIA568C.2 and ISO/IEC11801
- 4 pairs totally insulated throughout the connector
Minimum cross-talk between the four pairs.
- Patented special interfacial shapes
Minimum perturbation at the interface of each pair.
- 38999 size 11 shell with a choice of materials & platings :
 - Aluminium with Olive drab cadmium, Nickel ✓
 - or Black Zinc Nickel ✓ plating
 - Marine bronze ✓
- IP68 sealing mated and unmated for PCB receptacles.
- 1500 Vrms dielectric withstanding voltage.
- Temperature range: - 55°C / + 125°C.
- Machined & gold plated solder and crimp contacts
Design & performance according to the innercontact of:
M39029/77-429#16 M39029/76- 425#16 38999 Coaxial contact.
Contacts are crimped with standard crimping tool M22520/2-01:
+ Amphenol μ Com positioner.
- μ Com contact module: machined brass.
- Solder contact: max AWG24.
- Crimp contact: AWG 24 to 28.



<p>Plug TV06UCOM***</p>	<p>Square flange receptacle TV00UCOM***</p>	<p>Jam nut Receptacle TV07UCOM***</p>	<p>Stand-off Receptacle TV00UCOM***F459</p> <p>Also available in Jam nut TV07UCOM***F459</p>	<p>Stand-off Reduced flange Jam nut Receptacle TV07UCOM***F059</p>
------------------------------------	--	--	--	---

<p>3:32</p>	<p>Scan & discover !</p>	<p>2:41</p>	<p>Scan & discover !</p>
-------------	------------------------------	-------------	------------------------------

✓ : RoHS compliant
All dimensions are given for information only and are in mm, except as otherwise specified | *in mm: 1mm=0.03937 inch

Series III TV-CTV
Series II JT
Series I LJT
Accessories & tools
Assembly instructions

MIL-DTL-38999 SERIES III DERIVED RANGE - TV μ COM - 10GB+

Data Transmission



Insertion Loss (IL)

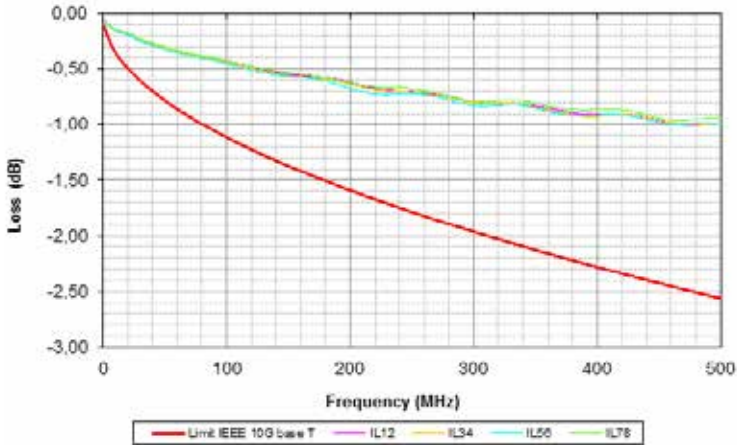

← Amphenol μ Com performance

← IEEE 802.3an Standard requirement

Near end crosstalk (NEXT)

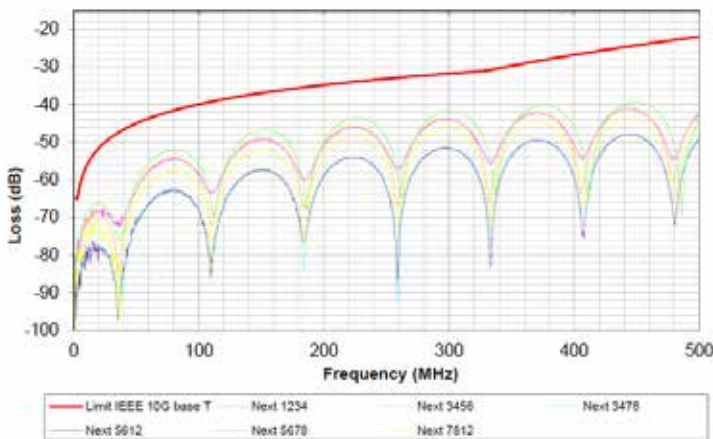

← IEEE 802.3an Standard requirement

← Amphenol μ Com performance

Return loss (RL)

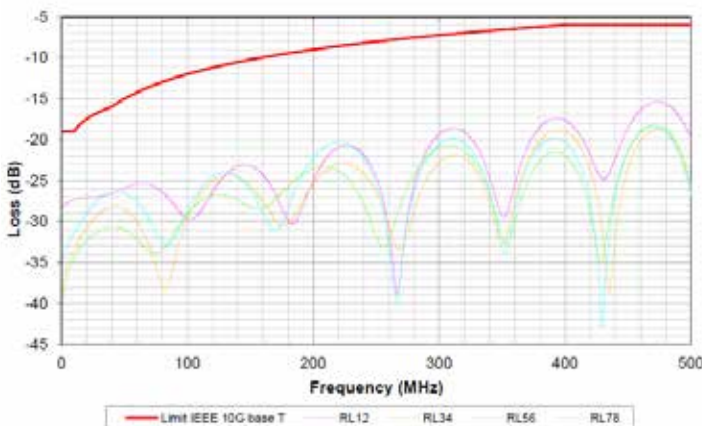

← IEEE 802.3an Standard requirement

← Amphenol μ Com performance

All dimensions are given for information only and are in mm, except as otherwise specified | *in mm: 1mm=0.03937 inch

Due to technical modifications, all information provided is subject to change without prior notice
Designed by Amphenol Socapex

MIL-DTL-38999 SERIES III DERIVED RANGE - HOW TO ORDER TVμCOM

Amphenol Designations - TVμCOM Crimp & Solder Cup connectors

	1.	2.	3.	4.	5.	6.
Series	Shell type	Contact type	Material and platings	Shell size	Contact gender	Deviation
TV	07UCOM	C	W	11	S	F312

1. Shell type

07UCOM	Jam nut receptacle
P00UCOM	Square flange receptacle
06UCOM	Straight plug

2. Contact type

C	Crimp
S	Solder cup

3. Material and platings

	Shell material	Shell finish
W	Aluminum	Olive drab cadmium
F		Nickel ✓
ZN		Black zinc nickel ✓
B		Marine bronze * ✓

* Copper aluminum alloy

4. Shell size

11	Available in size 11 only
----	---------------------------

5. Contact gender

P	Male μCOM module
S	Female μCOM module

6. Deviation - for Jam nut receptacles only

Deviation	Description	Shell type compatibility
F312	Reduced flange receptacle with a standard nut	07UCOM
F311	Reduced flange receptacle with a safety castle nut	

For other deviations, please consult us

Amphenol Designations - TVμCOM PCB Connectors

	1.	2.	3.	4.	5.	6.
Series	Shell type	Contact type	Material and platings	Shell size	Contact gender	Deviation
TV	07UCOM	C	W	11	S	F459

1. Shell type

07UCOM	Receptacle	Jam nut receptacle
P00UCOM		Square flange receptacle

2. Contact type

CI	PC Tail
----	---------

3. Material and platings

	Shell material	Shell finish
W	Aluminum	Olive drab cadmium
F		Nickel ✓
ZN		Black zinc nickel ✓
B		Marine bronze * ✓

* Copper aluminum alloy

4. Shell size

11	Available in size 11 only
----	---------------------------

5. Contact gender

S	Female μCOM module only
---	-------------------------

6. Deviation

Deviation	Description	Shell type compatibility
F459	Stand-off	All
F312	Reduced flange	07UCOM
F311	Reduced flange with a safety castle nut	
F059	Stand-off reduced flange	
F058	Reduced flange receptacle with a safety castle nut	

For other deviations, please consult us

Amphenol Designations - TVμCOM Backshell

	1.	2.
Series	Material and plating	Backshell type
TVUCOM	W	B

2. Material and platings

	Shell material	Shell finish
W	Aluminum	Olive drab cadmium
F		Nickel ✓
ZN		Black zinc nickel ✓

✓ RoHS compliant

All dimensions are given for information only and are in mm, except as otherwise specified | *in mm: 1mm=0.03937 inch

3. Backshell type

B	Backshell with banding platform
G	Backshell with gland

Series III TV-CTV
Series II JT
Series I LJT
Accessories & tools
Assembly instructions

MIL-DTL-38999 SERIES III DERIVED RANGE - TV μ COM - 10GB+

Overall dimensions Square flange - Wall mount Receptacle

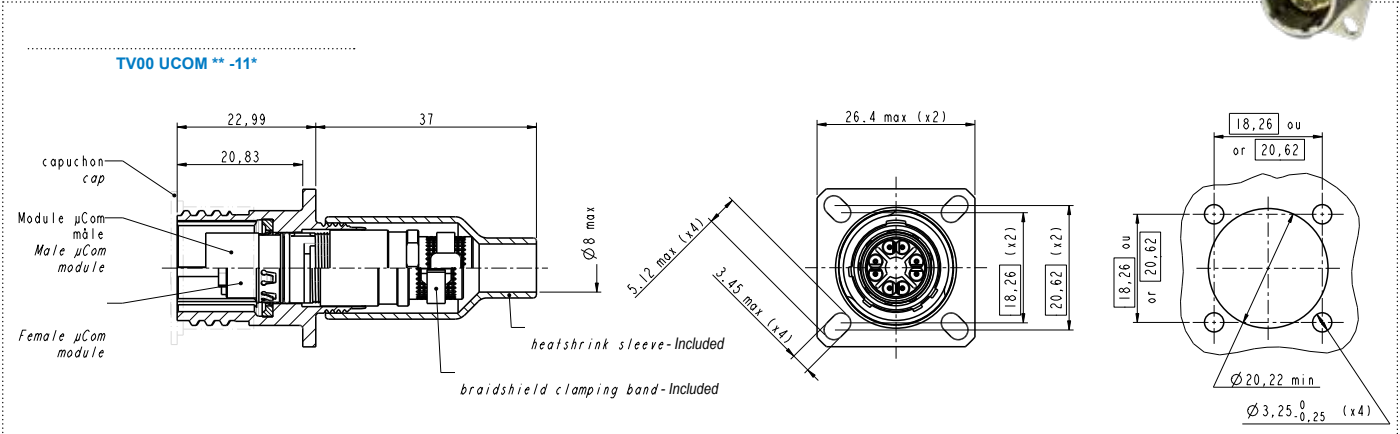

Jam nut Receptacle

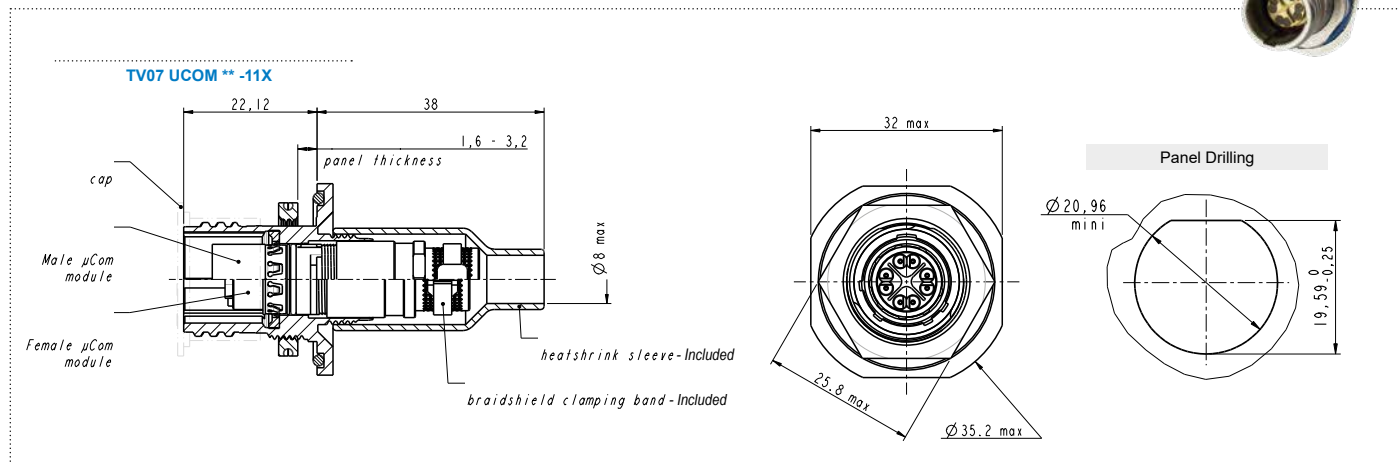

Stand-Off Square Flange Receptacle

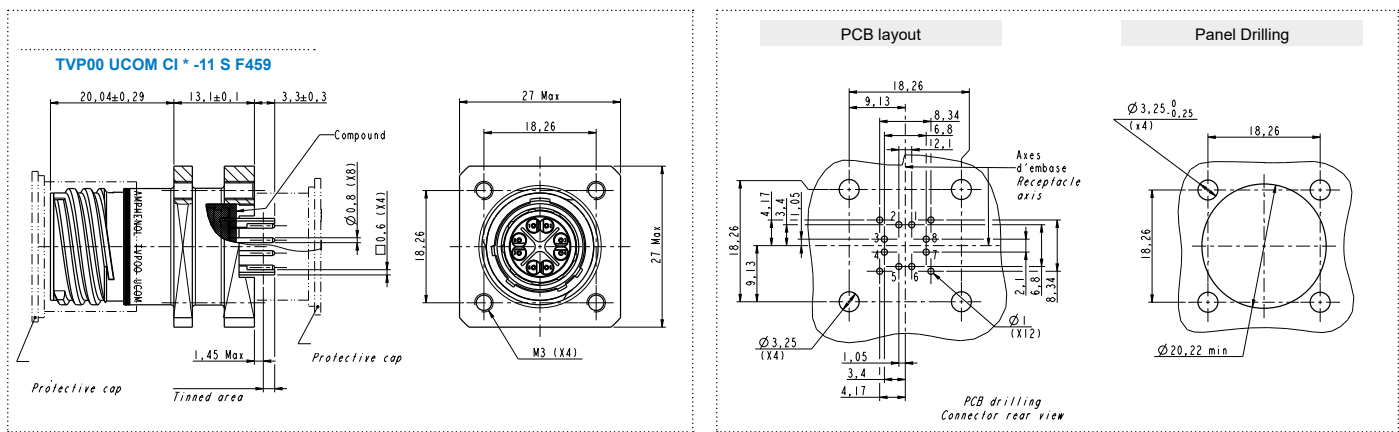

All dimensions are given for information only and are in mm, except as otherwise specified | *in mm: 1mm=0.03937 inch

Due to technical modifications, all information provided is subject to change without prior notice
Designed by Amphenol Socapex

MIL-DTL-38999 SERIES III DERIVED RANGE - TV μ COM - 10GB+

Stand-Off Jam nut Receptacle

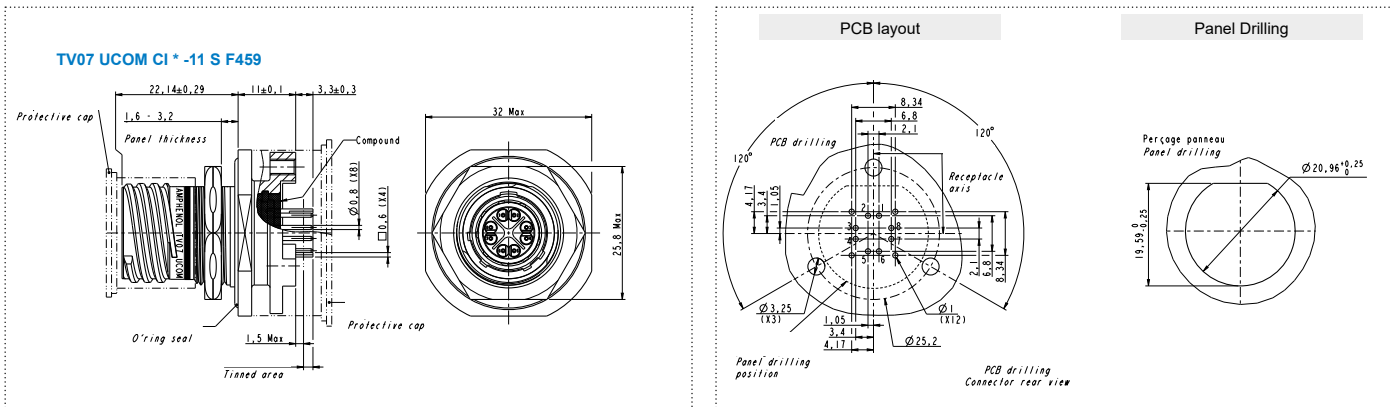

Stand-Off Reduced flange Receptacle

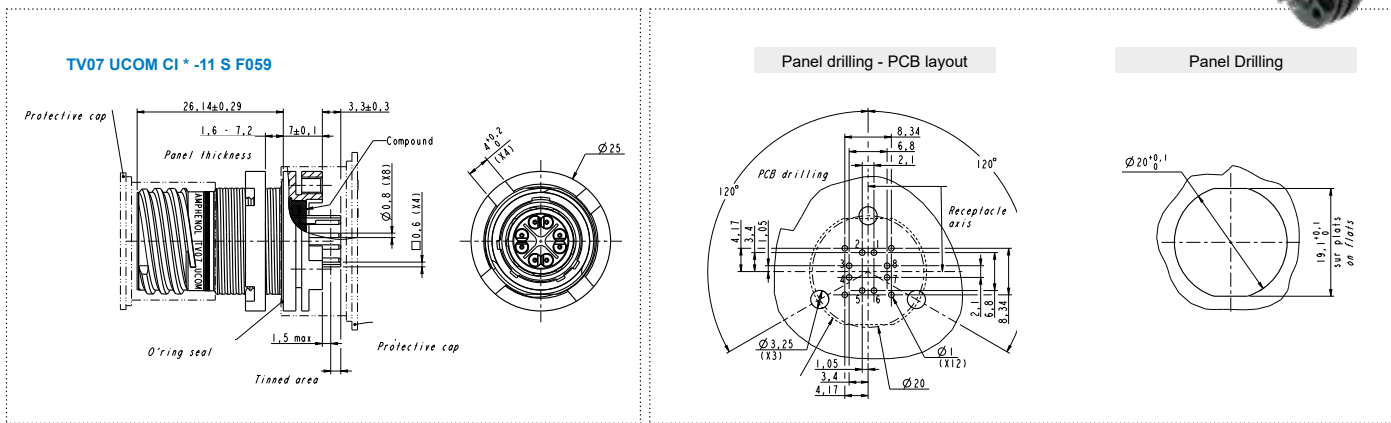

Straight plug

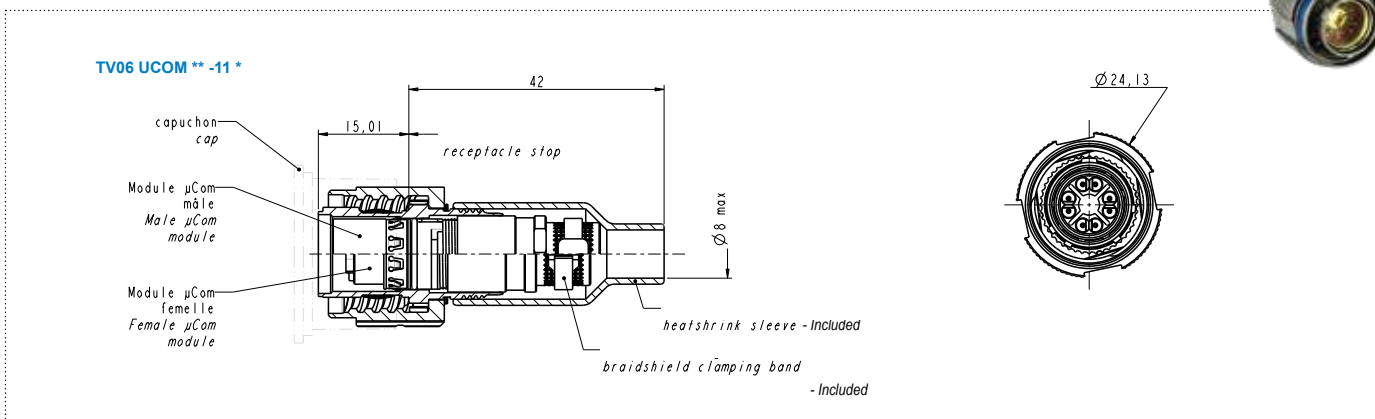

All dimensions are given for information only and are in mm, except as otherwise specified | *in mm: 1mm=0.03937 inch

Due to technical modifications, all information provided is subject to change without prior notice
Designed by Amphenol Socapex

MIL-DTL-38999 SERIES III DERIVED RANGE - TV μ COM - 10GB+

Backshells

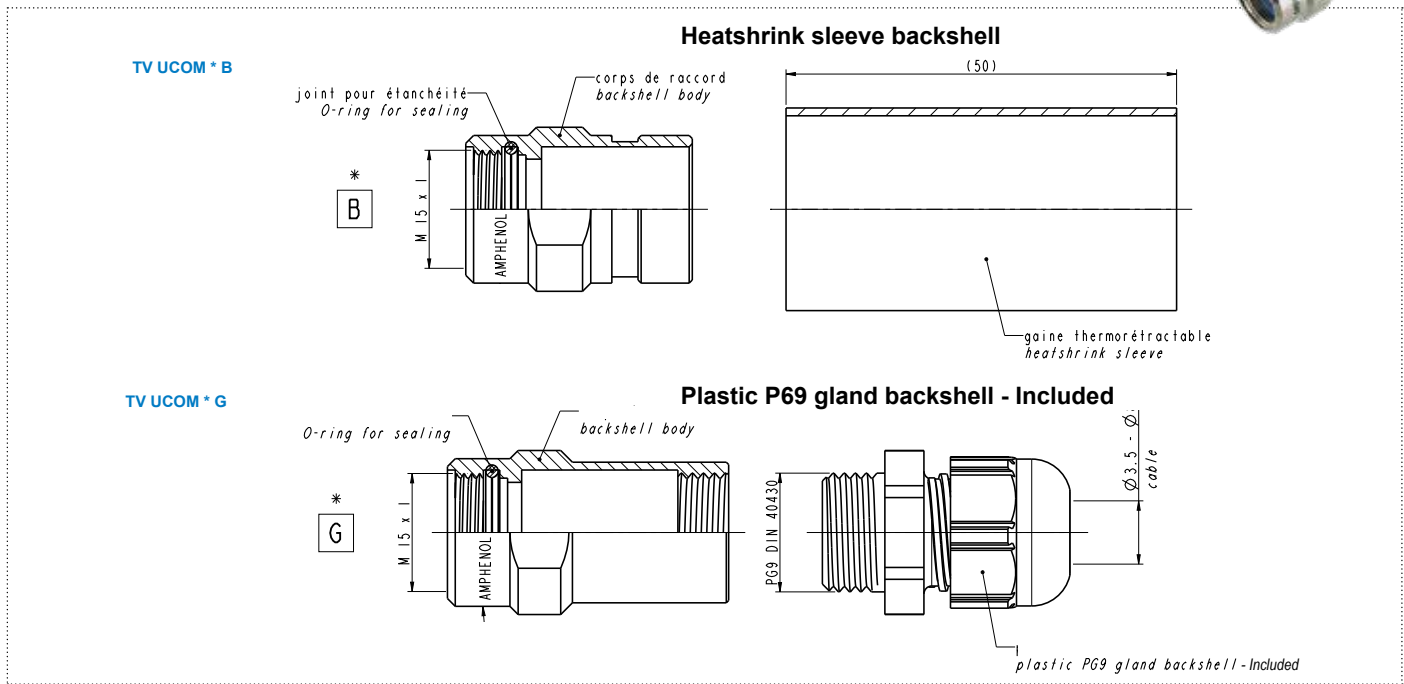

Tooling Removal tool

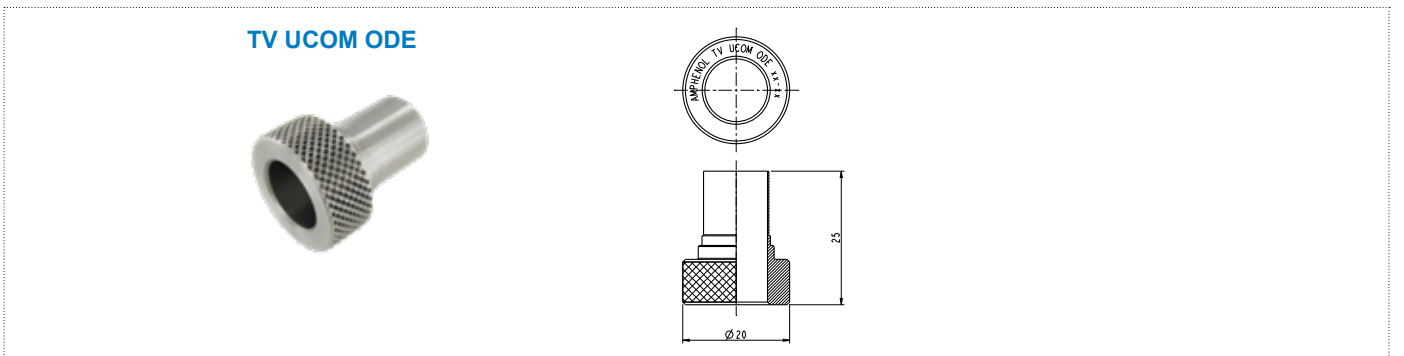

Contacts tool

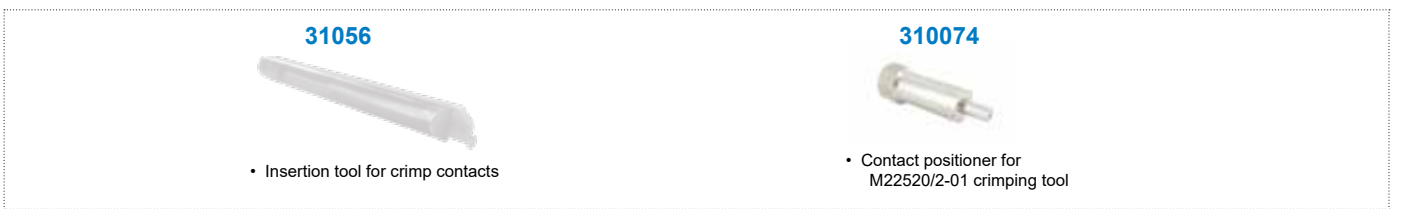

Nota: the cabling instructions are available upon demand (ref. N00-040190-00).

Spares



Panel gasket for TVP00



All dimensions are given for information only and are in mm, except as otherwise specified | *in mm: 1mm=0.03937 inch

Due to technical modifications, all information provided is subject to change without prior notice
 Designed by Amphenol Socapex

MIL-DTL-38999 SERIES III DERIVED RANGE - TVOP - FIBER OPTIC IN A 38999 SHELL

38999 shell with Standard Optical termini (Ø 2.5 mm).



Description

The TVOP connector is an optical version of the MIL-DTL-38999 Series III connector, which uses standard 2.5 mm telecom optical termini in dedicated high precision inserts. It is designed to provide high level of performance and reliability and cost effective solution for outdoor and indoor applications.

Main features

- 1 to 8 channels.
- Available in multimode, singlemode PC and singlemode APC.
- 0.5 dB typical insertion loss in multimode and singlemode.

Arrangement



11-2



13-4

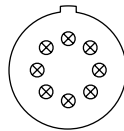

17-8

MIL-DTL-38999 SERIES III DERIVED RANGE - STARTOP - 38999 WITH FIBER OPTIC

38999 shell with Optical termini size 16 MIL-PRF-29504.



Description

The STARTOP connector is made of standard MIL-DTL-38999 electrical connectors, using size 16 MIL-PRF-29504 optical termini. Hybrid versions (electrical and optical) are available, for further details please consult us.

Main features

- 1 to 8 channels.
- Available in multimode.
- 0.8 dB typical insertion loss.

Arrangements



11-02

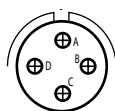

13-04

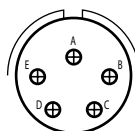

15-05

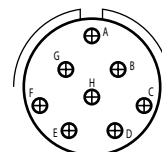

17-08

For further details, please consult the EWOC catalog (DOC-000503-ANG).

MIL-DTL-38999 SERIES III DERIVED RANGE - HOW TO ORDER FIBER OPTICS

Amphenol Designations - TVOP Connectors

1.	2.	3.	4.	5.	6.	7.	8.
Series	Shell type	Material and platings	Backshell type	Shell size - Number of channel	Type of ceramic ferrule / Ceramic ferrule inner diameter	Keying	Cable option
TVOP	06	F	H0	11 - 2	P6	N	X015

1. Series

TVOP	TV shell with fiber optic
------	---------------------------

2. Shell type

06	Straight plug
00	Square flange receptacle
07	Jam nut receptacle

3. Material and platings

	Shell material	Shell finish
W		Olive drab cadmium
F	Aluminum	Nickel ✓
ZN		Black zinc nickel ✓
B	Marine bronze * ✓	-

* Copper aluminum alloy

4. Backshell type

H0	Straight heatshrinkable backshell without clamp
H9	Right angle heatshrinkable backshell without clamp
S3	Straight backshell for multiway cable with metal integrated clamp
S4	Straight backshell for multiway cable with plastic integrated clamp
S5	Straight backshell for multiway cable with tightening jaws clamp
R0	Straight backshell for pigtails (for receptacles only)

5. Shell size / Number of channel

07-1	Size 7 - 1 channel max (387TV)
11-2	Size 11 - 2 channels max
13-4	Size 13 - 4 channels max
17-8	Size 17 - 8 channels max

6. Type of ceramic ferrule / Ceramic ferrule inner diameter

Multimode	P7	Physical contact ferrule. 127 µm
Singlemode	P6	Physical contact ferrule. 126 µm
	A	Angle physical contact ferrule. 126 µm

7. Keying

N (for normal)	A	B	C	D	E
-------------------	---	---	---	---	---

8. Cable option

X055	Ø 5.5mm multiway cable (for backshell H0, H9, S3, S4, S5)
X015	Ø 1.5mm for pigtail (for backshell R0 only)

Amphenol Designations - StartOP

1.	2.	3.	4.	5.	6.	7.	8.	9.	
Series	Angle type	Backshell type	Shell type	Shell size	Keying	Cable option	Material and platings	Nb of termini	Optical termini Multimode
STA	00	S	EF	11	N	110	RW	2	A1

1. Angle type

00	Straight
90	Right angle (only for heatshrinkable backshells)

2. Backshell type

S	Straight backshell for multiway cable with tightening jaws clamp
P	Straight backshell for multiway cable with metal integrated clamp
T	Heatshrinkable backshell without clamp
R	Straight backshell for pigtail

3. Shell type

MF	Plug	Male plug
FF		Female plug
EF	Receptacle	Female Jam nut receptacle
EM		Male Jam nut receptacle
VF		Female Square flange receptacle
VM		Male Square flange receptacle

4. Shell size (Number of optical termini)

11	2 optical termini
13	4 optical termini
15	5 optical termini
17	8 optical termini

5. Keying

N (for normal)	A	B	C	D	E
-------------------	---	---	---	---	---

6. Cable option

015	Ø 1.5mm (only for pigtail backshell - 'R' backshell)
055	Ø 5.5mm for multiway cable
110	Ø 110mm multiway cable

These are just diameter exemple. Contact us for other diameter requests.

7. Material and platings

	Shell material	Shell finish
RW		Olive drab cadmium
RF	Aluminum	Nickel ✓
ZN		Black zinc nickel ✓
RB	Marine bronze * ✓	-

* Copper aluminum alloy

8. Number of optical termini

0	For connectors delivered without optical termini
2	For size 11 shell
4	For size 13 shell
5	For size 15 shell
8	For size 17 shell

9. Optical termini multimode

A1	For fiber multimode 50/125 or 62.5/125
----	--

✓ RoHS compliant

All dimensions are given for information only and are in mm, except as otherwise specified | *in mm: 1mm=0.03937 inch

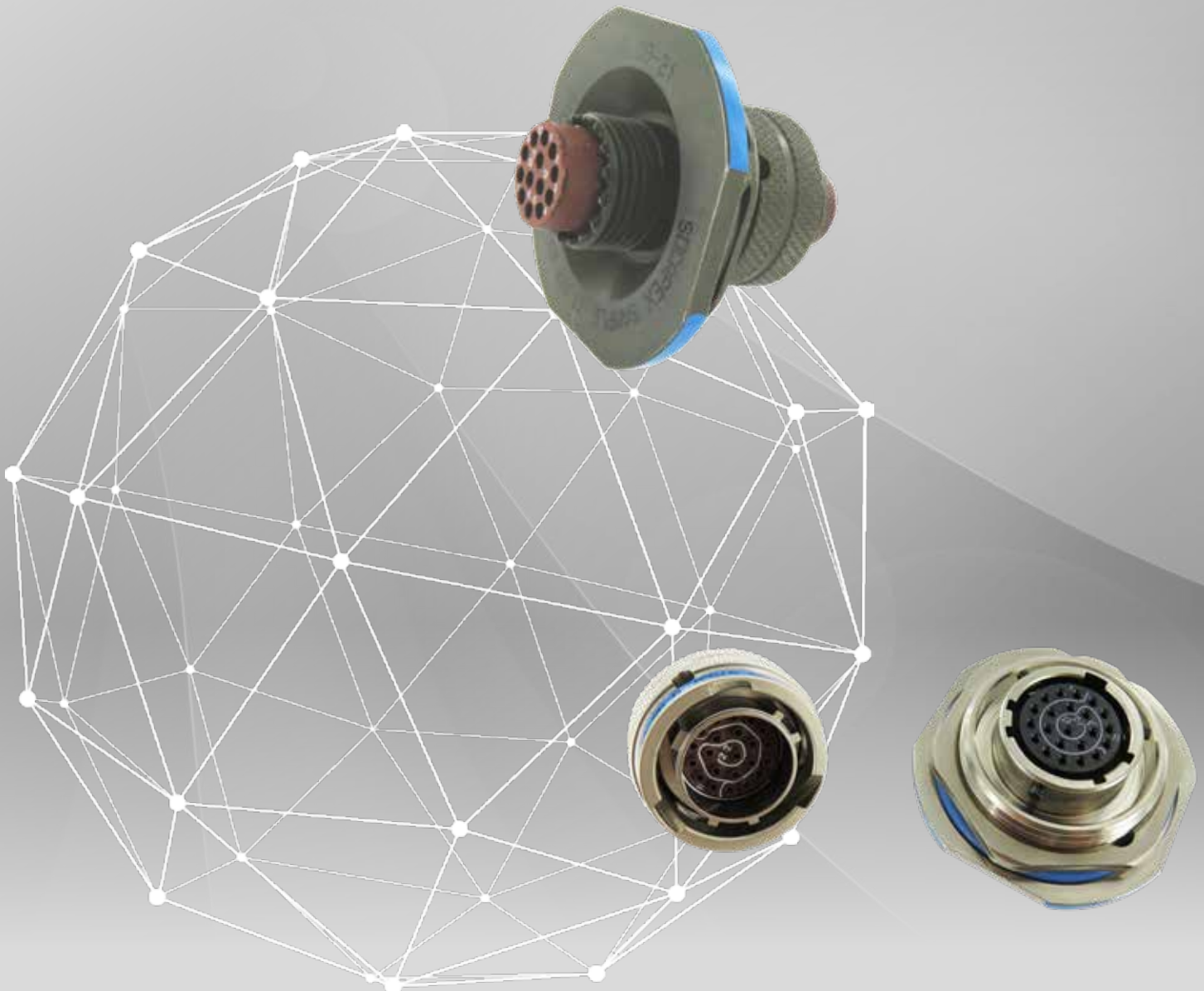
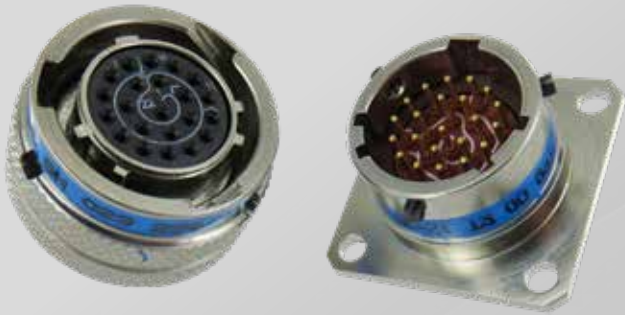

MIL-DTL-38999 SERIES II, JT RANGES



Table of contents

MIL-DTL-38999 Series II, JT / STANDARD, EXTENDED & DERIVED RANGES	151
STANDARD RANGE - JT SERIES	152
General characteristics	152
Technical characteristics	153
Electrical characteristics	154
JT Series (MS27***)	157
EXTENDED RANGE	161
Stand-Off receptacle - F459	161
Integrated backshell - F472	163
DERIVED RANGE	164
SC39 LP - Breakaway Low Profile connector	164

THE SERIES II JT SERVES VARIOUS MARKETS, INCLUDING:



Commercial Avionics & Airframe



Military Avionics & Airframe



Military vehicles



C4ISR

All dimensions are given for information only and are in mm, except as otherwise specified | *in mm: 1mm=0.03937 inch

MIL-DTL-SERIES II, JT - GENERAL CHARACTERISTICS

Light weight & space saving designed connectors for aerospace

Description

The JT connectors are in accordance with MIL-DTL-38999 Series II standard. These connectors were developed to meet the needs of the aerospace industry. They offer a large variety of contact arrangements and shell styles, with maximum weight/space savings and reliability.



Main features

LOW PROFILE CONNECTOR, LIGHTWEIGHT & SPACE SAVING DESIGN COMPARE TO LJT - MIL-DTL-38999 SERIES I.

3 POINTS BAYONET LOCK SYSTEM: Quick positive coupling

CONTACT PROTECTION: Improved interfacial seal ensures sealing around each contact

EMI/RFI PROTECTION: Optional grounding fingers on the plug shell

9 shell sizes from 08 to 24

SHELL MATERIALS & FINISHES

Aluminum with Olive Drab Cadmium, Nickel ✓ or Black Zinc Nickel ✓ plating

DIFFERENT STYLES & OPTIONS AVAILABLE:

- Jam nut & Square flange - wall mount and box mount, in-line receptacle, straight plug
- Available with Stand-off double flange for receptacles **JT***F459**
- Available with integrated backshells **JT***F472**
- Enhanced sealing versions **JT***ETC*****

CONTACTS ARRANGEMENTS & TERMINATIONS:

- More than 50 arrangements of contacts (see page 18)
- Size 12, 16, 20, 22D contacts
- Crimp, PCB, signal and power contacts

Concept

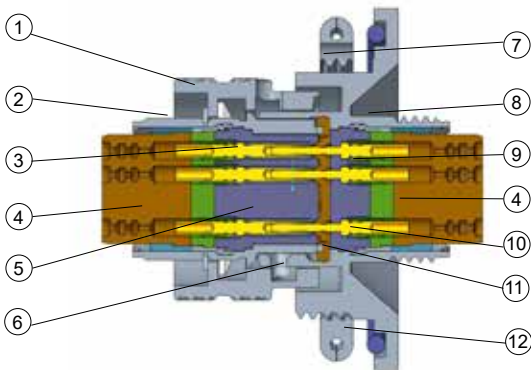

- ① Coupling nut
- ② Plug shell
- ③ Socket insert
- ④ Grommet
- ⑤ Crimp Socket contact
- ⑥ Rivet
- ⑦ O'Ring
- ⑧ Receptacle shell
- ⑨ Pin insert
- ⑩ Crimp Pin contact
- ⑪ Interfacial seal
- ⑫ Hex nut

Materials and platings

	Material	Plating	Benefit
Shell	Aluminum	Olive drab cadmium, Nickel, Black zinc nickel	Robust standard material
Insert	Thermoplastic		
Grommet and interfacial seal	Fluorosilicone		
Contact	Copper alloy	Gold, tin, silver tin, silver tin copper	

✓ : RoHS compliant

All dimensions are given for information only and are in mm, except as otherwise specified | *in mm: 1mm=0.03937 inch

Series III TV-CTV
Series II JT
Series I LJT
Accessories & tools
Assembly instructions

MIL-DTL-SERIES II, JT - TECHNICAL CHARACTERISTICS

Materials characteristics

	Shell material	Shell finish	Salt spray exposure per EIA 364.26 (hours)	Class norm	Amphenol designation	Operating temperature (°C)	
						Min	Max
Waterproof (IP X7)	Aluminum	Olive drab cadmium	500	B	JT** 014	- 65	+ 175
		Nickel	48	F	JT** 023	- 65	+ 200
		Black zinc nickel	96	-	JT** 033K	- 65	+ 175

Mechanical characteristics

Characteristics	MIL-DTL-38999				
Durability	500 cycles				
Shock	Half sine wave of 300 G magnitude during 3ms per EIA-364-27				
Vibration	Sine vibrations: - 60g from -55° to +175° (Olive drab cadmium and Black zinc nickel) - 60g from -55° to +200° (Nickel and Stainless steel)				
	Random vibrations: per EIA-364-28: - 43.92 grms at 175°C (Olive drab cadmium and Black zinc nickel), 50 to 2000 Hz - 43.92 grms at 200°C (Nickel and Stainless steel), 50 to 2000 Hz - 50.09 grms at ambient air Consult us for Durmalon (Nickel PTFE) and Green Zinc cobalt				
Contact retention force	Size	22D	20	16	12
	Max load (N)	45	67	110	110

Environmental characteristics

Characteristics	MIL-DTL-38999. M version. Amendment 2
Humidity	§3.29
Air leakage	§3.10
Fluid immersion	Per EIA 364.10 : - Hydraulic fluid, per MIL-H-5606. - Turbine fluid, grade JP-8, per MIL-DTL-83133 (NATO TYPE 34). - Lubricating oil, per MIL-L-7808. - Lubricating oil, per MIL-PRF-23699. - Defrosting fluid, per MIL-A-8243. - Cleaning compound, diluted for cleaning, per MIL-PRF-87937 type I alkaline base. - Gasoline, per ASTM-D-4814.- Gasohol, per A-A-52530. - One part isopropyl alcohol, per TT-I-735, grade A or B ; and 3 parts mineral spirits, per A-A-2904, type II, grade A or P-D-680, type I, by volume. - Coolant, dielectric fluid, synthetic silicate ester base MIL-PRF-47220 (Coolanol 25) or equivalent. - Hydraulic fluid M2-V Chevron oil ST0145LB0001 or equivalent;

Keyway position

A plug with a given rotation letter will mate with a receptacle with the same rotation letter. The angles for a given connector are the same whether it contains pins or sockets. Master key stays fixed, minor keys rotate. Inserts are not rotated in conjunction with the master key/keyway.

Shell Size	Normal	References			
		A	B	C	D
8	100°	82°	-	-	118°
10	100°	86°	72°	128°	114°
12	100°	80°	68°	132°	120°
14	100°	79°	66°	134°	121°
16	100°	82°	70°	130°	118°
18	100°	82°	70°	130°	118°
20	100°	82°	70°	130°	118°
22	100°	85°	74°	126°	115°
24	100°	85°	74°	126°	115°

RECEPTACLE (front face shown)
Main keyway

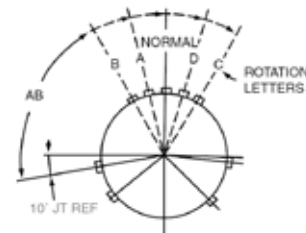

All dimensions are given for information only and are in mm, except as otherwise specified | *in mm: 1mm=0.03937 inch

MIL-DTL-SERIES II, JT - ELECTRICAL CHARACTERISTICS

Service rating

Service rating	Dielectric withstanding voltage (Vrms)								Working voltage	
	At sea level		15 000 meters		21 000 meters		34 000 meters		Vms	Vdc
	Mated	Unmated	Mated	Unmated	Mated	Unmated	Mated	Unmated		
N	1000	1000	-	400	-	260	-	200	300	450
M	1300	1300	800	550	800	350	800	200	400	550
I	1800	1800	1000	600	1000	400	1000	200	600	850
II	2300	2300	1000	800	1000	500	1000	200	900	1250

Contacts and cables

For more information about contacts, please refer to the dedicated "Contacts" catalog DOC-000081-ANG

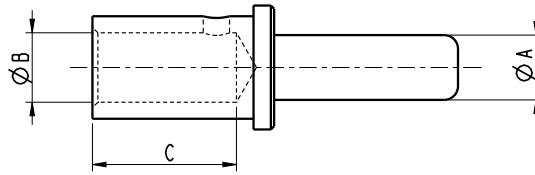

Contact characteristics		Contact size			
	Contact termination	22D	20	16	12
Contact rating (nominal current per contact, A) at ambient temperature	Crimp barrel	5	7.5	13	23
	PC tail	3	4.5	10	17
	Hermetic	3	5	10	17
Contact resistance (without wire, mΩ)		8	4.7	2	1.1
Insulation resistance (MΩ)		> 10 ⁵ at ambient temperature > 10 ³ at maximum temperature			
ØA Pin contact diameter (mm) (mating area)		0.76	1	1.57	2.36
Crimp barrel	ØB Diameter (mm)	0.88 ± 0.03	1.19 ± 0.03	1.70 ± 0.03	2.54 ± 0.06
	C Depth (mm)	3.58	5.30	5.30	10
Cable dimensions: (Section in mm ²)	American wire gauge AWG				
	28	0.095			
	26	0.15			
	24		0.22		
	22		0.38		
	20			0.60	
	18			0.93	
	16			1.34	
	14				1.94
Outside diameter (mm)	MIN	0.76	1.02	1.68	2.46
	Average	1.20	1.83	2.41	3.20
	MAX	1.37	2.11	2.77	3.61

** Consult us for other cable dimensions

All dimensions are given for information only and are in mm, except as otherwise specified | *in mm: 1mm=0.03937 inch

MIL-DTL-SERIES II, JT - HOW TO ORDER - JT CONNECTORS

Military Designations - DLA MIL-DTL-38999 SERIES II Connectors

	1.	2.	3.	4.	5.	6.	7.
Series	Shell type	Service class	Shell size	Material and platings	Contact arrangement	Contact gender	Keying
MS27	472	T	10	F	35	P	A

1. Shell type

Series	Shell type	Description
472	Receptacle	Wall mounting receptacle (front panel)
497		Wall mounting receptacle (back panel)
499		Box mounting receptacle (front panel - RE version only)
508		Box mounting receptacle (back panel - RE version only)
474	Plug	Jam nut receptacle
473		Straight plug
484		Straight plug with grounding fingers

2. Service class

Service class	Shell type compatibility	Description
T	00 / PQ00 / 01 / 07 / 06 / G06	Crimp contacts provided with thread accessory
E	All shell types	Crimp contacts provided with compression nut

3. Shell size

08	10	12	14	16	18	20	22	24
----	----	----	----	----	----	----	----	----

4. Material and platings

	Shell material	Shell finish
B	Aluminum	Olive drab cadmium
F		Nickel ✓

5. Contact arrangements

Refer to page 18 for contact arrangements. - JT / MIL-DTL-38999 Series II. Only take the second number of the insert arrangement which is the contact.

6. Contact gender

P	Pin (500 cycles)
S	Socket (500 cycles)

Always delivered with contacts.

7. Keying

Blank (for normal)	A	B	C	D
--------------------	---	---	---	---

Amphenol Designations - JT Crimp connectors

	1.	2.	3.	4.	5.	6.
Series	Shell type	Service class	Contact arrangement	Contact gender	Keying	Material and platings
JT	07	RT	14-35	P	-	014

1. Shell type

Series	Shell type	Description
00	Receptacle	Square flange receptacles (wall mount)
PQ00		Square flange receptacles (wall mount back panel)
01		Inline receptacle
02		Box mounting receptacle without rear thread (front panel)
P02	Plug	Box mounting receptacle without rear thread (back panel)
07		Jam nut receptacle
06		Straight plug
G06		Straight plug with grounding fingers

2. Service class

Service class	Shell type compatibility	Description
RT	00 / PQ00 / 01 / 07 / 06 / G06	Crimp contacts provided with thread accessory
RE	All shell types	Crimp contacts provided with compression nut

3. Contact arrangements

Refer to page 18 for contact arrangements. - JT / MIL-DTL-38999 Series II. First number represents the shell size and second number is the contact arrangement.

4. Contact gender

P	Pin (500 cycles)
S	Socket (500 cycles)
A	Without pin contacts
B	Without socket contacts

5. Keying

Blank (for normal)	A	B	C	D
--------------------	---	---	---	---

6. Material and platings

	Shell material	Shell finish
014	Aluminum	Olive drab cadmium
023		Nickel ✓

7. Deviation

Deviation	Description	Shell type compatibility
F472	Integrated backshell - Band-it width 6mm ±0.2	JT06

✓ RoHS compliant

All dimensions are given for information only and are in mm, except as otherwise specified | *in mm: 1mm=0.03937 inch

MIL-DTL-SERIES II, JT - HOW TO ORDER - JT CONNECTORS

Amphenol Designations - JT PCB Receptacles

	1.	2.	3.	4.	5.	6.
Series	Shell type	PC Tail contacts	Insert arrangement	Contact gender	Keying	Material and platings
JT	07	CI	14-35	P	-	014

1. Shell type (receptacles only)

PQ00	Wall mounting receptacle (back panel)
P02	Box mounting receptacle (back panel – RE version only)
07	Jam nut receptacle

2. PC tail contact

CI	Standard length
----	-----------------

3. Insert arrangements

Refer to page 18 for contact arrangements. - JT / MIL-DTL-38999 Series II.
First number represents the shell size and second number is the contact arrangement.

4. Contact gender

P	Pin (500 cycles)
S	Socket (500 cycles)

Connectors with PC Tail contacts are always delivered with contacts.
We recommend to use pin contacts.

5. Keying

Blank (for normal)	A	B	C	D
-----------------------	---	---	---	---

6. Material and platings

	Shell material	Shell finish
014	Aluminum	Olive drab cadmium
023		Nickel ✓

8. Deviation

Shell style	PC Tail finish / Tinning <i>(for Solder cup version, please use tin lead code)</i>				Shell type compatibility
	Tin lead	Silver tin ✓	Silver tin copper ✓	Gold ✓	
Standard (Tinned PC-Tails)	F404	F404LF	F404LFC	Blank	All
Stand-off	F459	F459LF	F459LFC	F459H	JTPQ00 JT07

For other deviations, please consult us.

All dimensions are given for information only and are in mm, except as otherwise specified | *in mm: 1mm=0.03937 inch

MIL-DTL-SERIES II, JT - OVERALL DIMENSIONS

Overall dimensions

Square Flange - Wall mount receptacle (Back panel mounting)

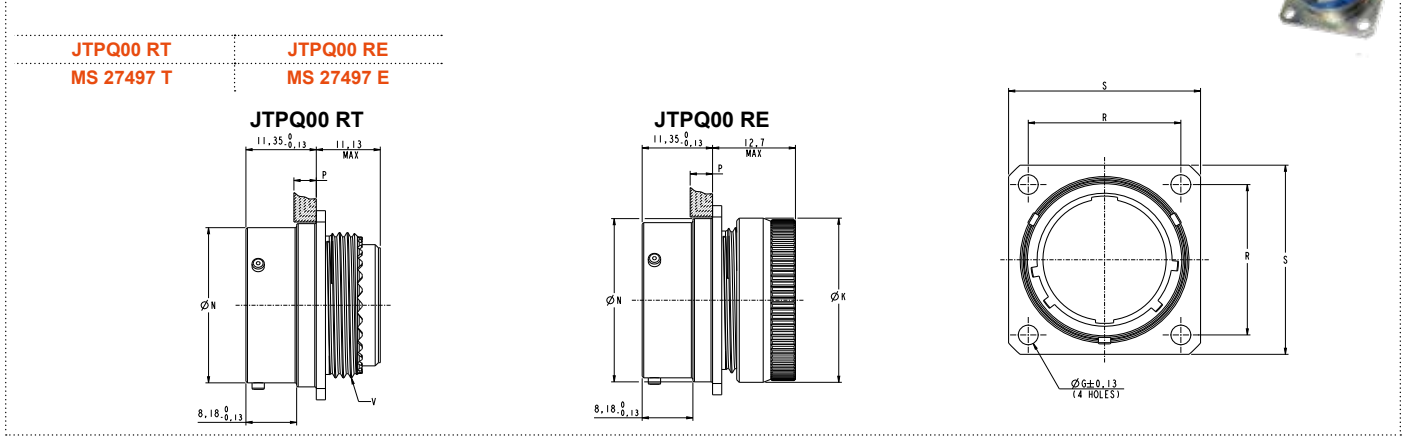

Shell size	$\begin{matrix} +0.025 \\ \text{ØN} \\ -0.13 \end{matrix}$	P_{MAX} Panel Thickness	V Thread UNEF Class 2A (plated)	ØK_{MAX}	R	$S_{\pm 0.41}$	$G_{\pm 0.13}$
8	12.01	3.61	.4375-28	14.68	15.09	20.62	3.05
10	14.99	3.61	.5625-24	17.86	18.26	23.82	3.05
12	19.05	3.61	.6875-24	21.03	20.62	26.19	3.05
14	22.23	3.61	.8125-20	24.21	23.01	28.58	3.05
16	25.4	3.61	.9375-20	27.38	24.61	30.96	3.05
18	28.58	3.61	1.0625-18	30.56	26.97	33.32	3.05
20	31.75	3.61	1.1875-18	33.73	29.36	36.53	3.05
22	34.93	3.61	1.3125-18	36.91	31.75	39.67	3.05
24	38.10	3.61	1.4375-18	40.08	34.93	42.88	3.73

Square Flange - Box mount receptacle (Back panel mounting)

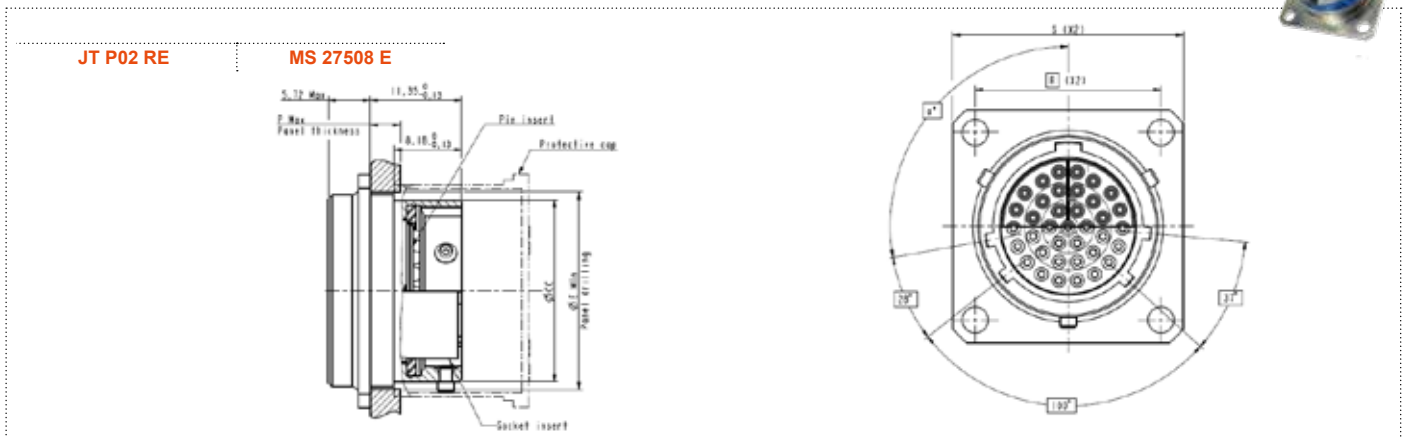

Shell size	$\begin{matrix} +0.03 \\ \text{ØCC} \\ -0.13 \end{matrix}$	ØE_{MIN}	S_{MAX}	R	P_{MAX}
8	12.01	14.15	21.03	15.09	3.71
10	14.99	17.32	24.23	18.26	
12	19.05	21.69	26.59	20.62	
14	22.23	24.87	28.98	23.01	
16	25.40	28.04	31.34	24.61	
18	28.58	31.22	33.73	26.97	
20	31.75	34.39	36.91	29.36	4.27
22	34.93	37.57	40.08	31.75	
24	38.10	40.74	43.26	34.93	

All dimensions are given for information only and are in mm, except as otherwise specified | *in mm: 1mm=0.03937 inch

MIL-DTL-SERIES II, JT - OVERALL DIMENSIONS

Jam nut receptacle



JT07 RT
MS 27474 T

JT07 RE
MS 27474E

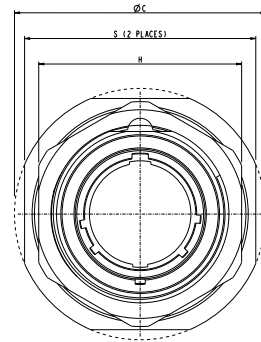
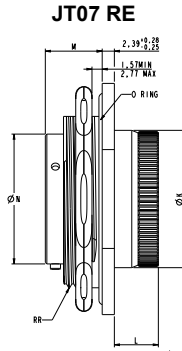
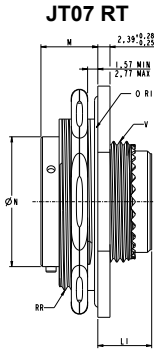

Shell size	$\begin{matrix} +0.025 \\ \text{ØN} \\ -0.13 \end{matrix}$	$M \pm 0.13$	RR Thread Class 2A (plated)	L^1_{MAX}	V Thread UNEF Class 2A (plated)	L_{MAX}	ØK_{MAX}	C_{MAX}	H Hex	$\begin{matrix} +0.43 \\ -0.41 \end{matrix}$	$S \pm 0.41$	Max torque value m/n
8	12.01	11.12	8750-20UNEF	11.51	4375-28	12.29	14.68	35.31	26.97	31.75	31.75	5.65
10	14.99	11.12	1.0000-20UNEF	11.51	5625-24	12.29	17.86	38.48	30.17	34.93	34.93	6.78
12	19.05	11.12	1.1250-18UNEF	11.51	6875-24	12.29	21.03	41.66	33.32	38.10	38.10	8.48
14	22.23	11.12	1.2500-18UNEF	11.51	8125-20	12.29	24.21	44.83	36.53	41.28	41.28	9.61
16	25.4	11.12	1.3750-18UNEF	11.51	9375-20	12.29	27.38	49.61	39.67	45.24	45.24	10.74
18	28.58	11.12	1.5000-18UNEF	11.51	1.0625-18	12.29	30.56	51.59	42.87	48.01	48.01	12.43
20	31.75	11.79	1.6250-18UNEF	10.72	1.1875-18	11.51	33.73	54.76	46.02	51.21	51.21	13.56
22	34.93	11.79	1.7500-18UNS	10.72	1.3125-18	11.51	36.91	57.91	50.8	54.36	54.36	14.69
24	38.10	11.79	1.8750-16UN	10.72	1.4375-18	9.53	40.08	61.09	53.98	57.53	57.53	16.95

In-line receptacle

JT01 RT

JT01 RE

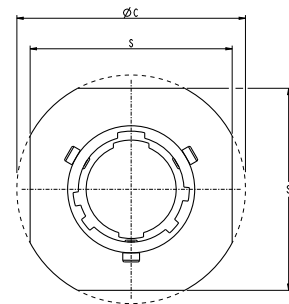
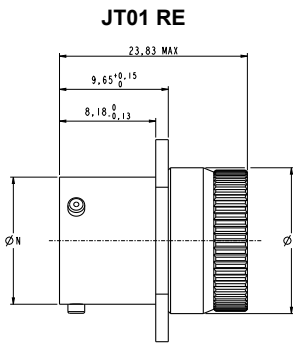
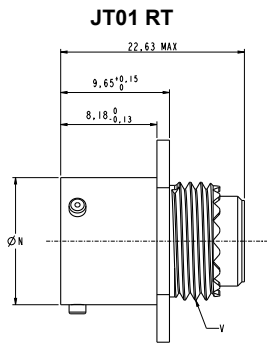

Shell size	$\begin{matrix} +0.025 \\ \text{ØN} \\ -0.13 \end{matrix}$	V Thread UNEF Class 2A (plated)	ØK_{MAX}	C	$\begin{matrix} +0.43 \\ -0.41 \end{matrix}$
8	12.01	4375-28	14.68	24.51	16.75
10	14.99	5625-24	17.86	27.66	23.83
12	19.05	6875-24	21.03	30.05	26.19
14	22.23	8125-20	24.21	32.44	28.58
16	25.4	9375-20	27.38	34.82	30.96
18	28.58	1.0625-18	30.56	37.21	33.32
20	31.75	1.1875-18	33.73	40.36	36.53
22	34.93	1.3125-18	36.91	43.56	39.67
24	38.10	1.4375-18	40.08	46.69	42.88

All dimensions are given for information only and are in mm, except as otherwise specified | *in mm: 1mm=0.03937 inch

MIL-DTL-SERIES II, JT - OVERALL DIMENSIONS

Straight plug

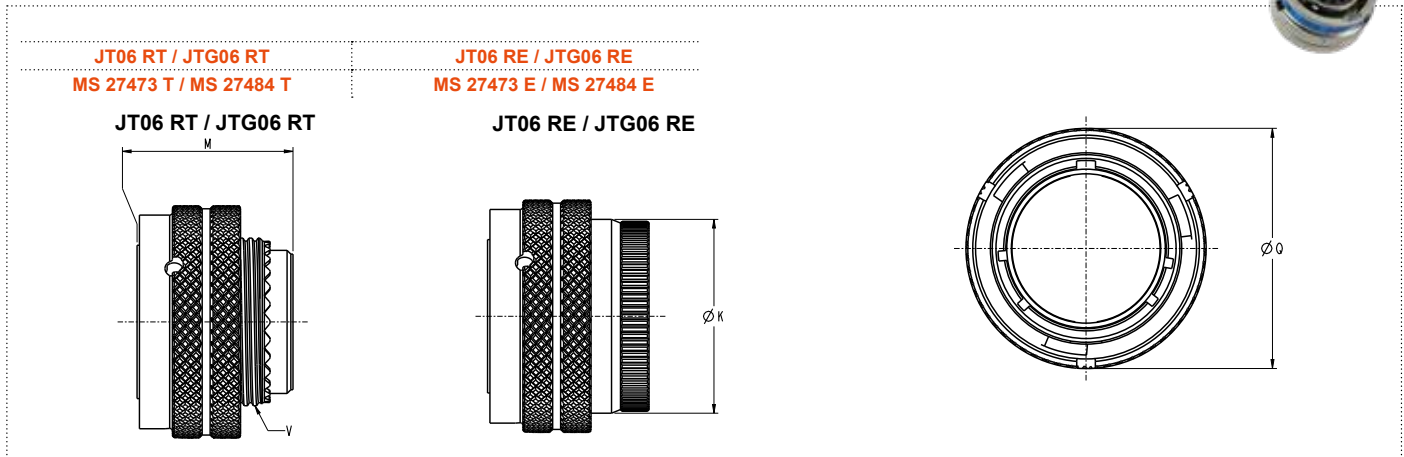

Shell size	M _{MAX}	V Thread UNEF Class 2A (plated)	ØK _{MAX}	ØQ _{MAX}
8	22.63	.4375-28	14.68	18.64
10	22.63	.5625-24	17.98	21.44
12	22.63	.6875-24	21.03	25.81
14	22.63	.8125-20	24.21	28.98
16	22.63	.9375-20	27.38	32.13
18	22.63	1.0625-18	30.56	35.33
20	22.63	1.1875-18	33.73	38.10
22	22.63	1.3125-18	36.91	41.28
24	22.63	1.4375-18	40.08	44.45

Panel Cutouts

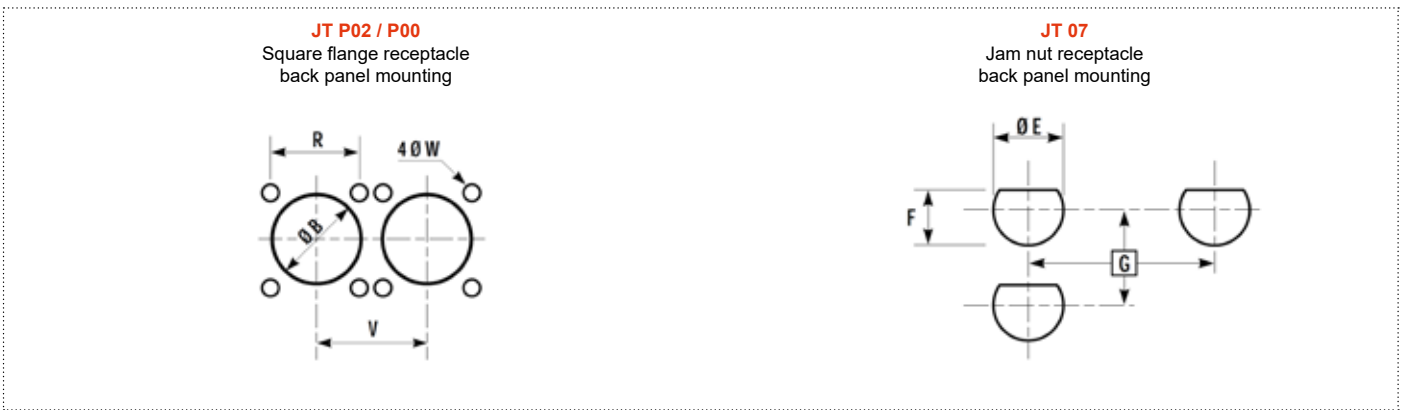

Shell size	R	B _{MIN}	V _{MIN}	W ^{±0.13}	E _{MIN}	F ^{+0 -0.25}	G _{MIN}
8	15.09	14.30	21.45	3.25	22.46	21.08	32.90
10	18.26	17.27	24.65	3.25	25.58	24.26	36.00
12	20.63	21.82	27.00	3.25	28.80	27.53	36.60
14	23.01	24.99	29.80	3.25	31.98	30.68	43.30
16	24.61	28.14	32.95	3.25	35.15	33.86	47.00
18	26.97	31.32	36.15	3.25	38.28	37.06	50.60
20	29.36	34.49	38.90	3.25	41.50	40.03	54.20
22	31.75	37.67	42.10	3.25	44.68	43.21	59.70
24	34.93	40.89	45.25	3.95	47.85	46.38	63.30

All dimensions are given for information only and are in mm, except as otherwise specified | *in mm: 1mm=0.03937 inch

MIL-DTL-SERIES II, JT - OVERALL DIMENSIONS - PC-TAILS RECEPTACLE

PC-Tail lengths - JT Receptacles (MIL-DTL-38999 Series II)

Dimensions given for Pin contacts with 5 mm PC Tails and Socket contacts with 4 mm PC Tails.



		JT 07 CI		JTPQ 00 CI
		08 to 18	20 to 24	08 to 24
Pin	L1	MIN	12.26	11.60
		MAX	13.23	12.57
	L2	MIN	17.16	16.50
		MAX	18.33	17.67
Socket	L1	MIN	12.06	11.40
		MAX	13.03	12.37
	L2	MIN	15.96	15.30
		MAX	17.13	16.47

Contact size	Ø A Max	
	CI (5mm contact length)	
	Gold plated contacts	Tin lead. Silver tin or Silver tin copper plated contacts
22	0.5	0.6
20	0.7	0.8
16	1.15	1.25
12	1.7	1.8

All dimensions are given for information only and are in mm, except as otherwise specified | *in mm: 1mm=0.03937 inch

MIL-DTL-SERIES II, JT EXTENDED RANGE - STAND-OFF RECEPTACLE

Double flange receptacles for PC tail applications.



Description

Double Flange receptacles for PC tail applications, to avoid stress on contact terminations while providing grounding continuity between the PCB & the box.

Main features

- Receptacle with Stand-off flange shell, for attachment to printed circuit boards.
- Prevent mechanical stress on the contact terminations.
- Provide grounding continuity between PCB and box.
- Increase reliability and resistance to shocks and vibrations.

OPTIONS:

- Square Flange - Wall mount (JT PQ00) or Jam nut (JT 07) shells.
- Tin plated or Lead free (tin-silver or tin-silver-copper) contacts finishes available.

AMPHENOL	DEVIATIONS
Lead tinned stand off	F459
Silver tinned stand off	F459LF
Silver copper tinned stand off	F459LFC

Overall dimensions

Jam nut receptacle



JT 07 CI ** F459**
JT 07 LI ** F459**

Size 8 and 10

Size 12 to 24

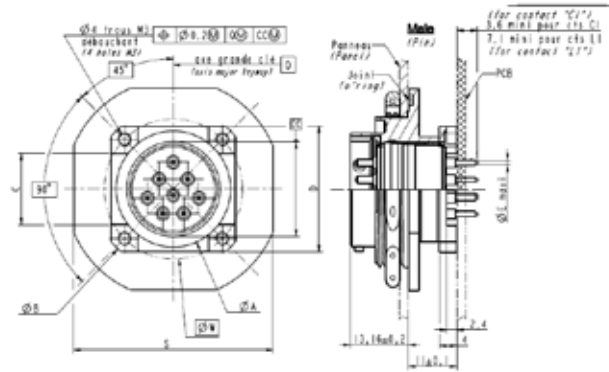
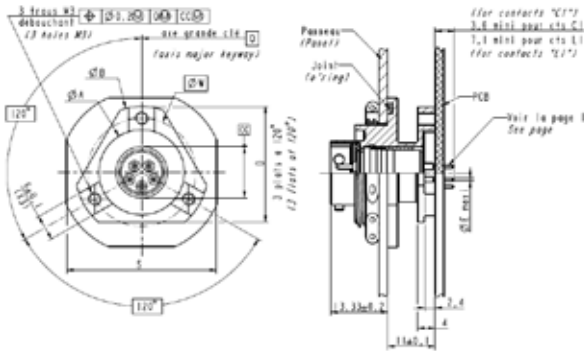

Shell size	ØA ±0.15	ØB ±0.15	C ^{+0.2} ₋₀	D ±0.1	ØW	S1 ±0.41
8	15.1	26	-	22	20.5	31.75
10	19.9	30.8	-	27	25.2	34.93
12	19.9	30.8	12	23.9	25.25	38.1
14	23	33.9	14	26.1	28.42	41.228
16	26	36.8	16	28.2	31.42	45.24
18	29.5	40.4	18	30.8	35.03	48
20	32	43.2	20	32.8	37.82	51.21
22	35.5	46.5	23	35.5	41.12	54.36
24	38.6	49.6	25	38	44.3	57.53

All dimensions are given for information only and are in mm, except as otherwise specified | *in mm: 1mm=0.03937 inch

MIL-DTL-SERIES II, JT EXTENDED RANGE - STAND-OFF RECEPTACLE

Square Flange - Wall Mount receptacle

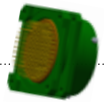

JT PQ00 CI ** F459**
 JT PQ00 LI ** F459**

Size 8 to 24

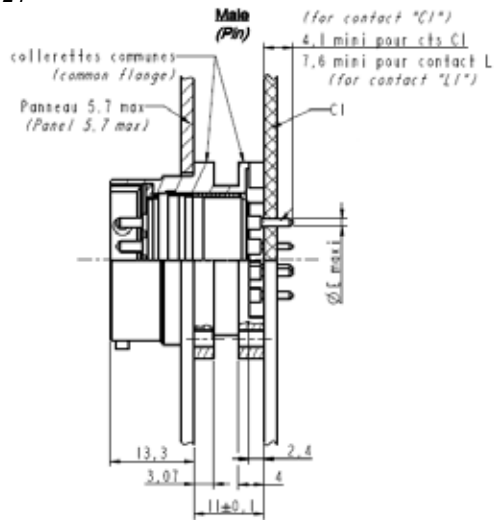
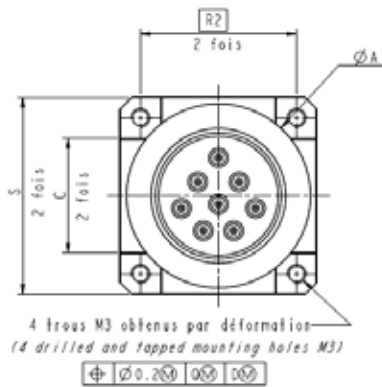

Shell size	ØA ^{±0.15}	C ^{+0.2 -0}	R2	S _{MAX}
8	15	9	15.09	21.03
10	20	12	18.26	24.23
12	23	14	20.62	26.59
14	26	16	23.01	28.98
16	29	18	24.61	31.34
18	32	20	26.97	33.73
20	35	22	39.36	36.91
22	38	26	31.75	40.08
24	41	26	34.93	43.26

All dimensions are given for information only and are in mm, except as otherwise specified | *in mm: 1mm=0.03937 inch

MIL-DTL-SERIES II, JT EXTENDED RANGE - INTEGRATED BACKSHELL

All-in-one 38999 Series II plugs with an integrated backshell



Description

JT series with integrated backshell are lightweight and low profile all-in-one solution offering great EMI performances and saving time during the installation.

Main features

- All-in-one product : time saving during order and installation
- High EMI Protection
- Quick, easy, cost effective cabling process
- Braid campling (micro and macro Band-it)

OPTIONS:

- Aluminum shells.
- Straight plugs, for receptacles consult us

AMPHENOL	DEVIATION
Integrated Backshell	F472

Overall dimensions Straight plug

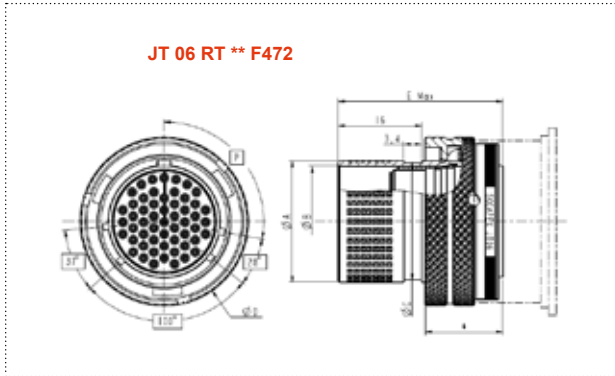

Shell size	ØA ⁺⁰ / _{-0.08}	ØB ^{+0.05}	ØC	ØD	E _{MAX}
8	10.70	8.71	9.81	18.4	32
10	13.77	11.96	13.06	21.4	
12	16.95	14.85	15.95	25.8	
14	20.10	18.03	19.13	29.2	
16	23.27	21.20	22.30	32.2	
18	26.27	23.90	25	35.6	
20	29.42	27.07	28.17	38	
22	32.59	30.25	31.35	41.2	
24	35.77	33.42	34.52	44.7	34

All dimensions are given for information only and are in mm, except as otherwise specified | *in mm: 1mm=0.03937 inch

MIL-DTL-SERIES II, JT DERIVED RANGE - SC39LP - LOW PROFILE BREAKAWAY

Low profile Breakaway connectors - Quick disconnect



Description

Quick disconnect range derived from MIL-DTL-38999 Series II. No coupling no threading. Instant decoupling and damage free separation with a direct pull on the harness. Quick breakaway fail-safe unmating Weight & space savings compare to others quick disconnect solutions on the market.

Main features

COMPACT & SPACE SAVING: 30% shorter than standard SC39 - see page 126.

38999 SERIES II CONTACTS ARRANGEMENT.

SHELLS

- Plug with integrated backshell
- Square flange and Jam nut receptacle.
- Size 08 to 14. Upper sizes available on request.
- N, A or B polarization

CONTACT PROTECTION

- Interfacial seal ensuring sealing around each contact.

MATERIAL

- Shell: Aluminum, Stainless steel
- Plating: Olive drab cadmium, Nickel, Passivation (Stainless steel).

Amphenol Designations - SC39LP Crimp connectors

	1.	2.	3.	4.	5.	6.	7.	8.
Series	Shell type	Low force option	Crimp contacts	Material and platings	Contact arrangement	Contact gender	Keying	With or without contacts
SC39LP	00	L	R	W	12-35	P	A	-

1. Shell type

	Shell type	Associated materials and platings	Temperature
06	Low profile plug	W	+175°C
S06*		F	+200°C*
00	Low profile Square flange receptacle	W	+175°C
S00*		F	+200°C*
07	Low profile Jam nut receptacle	W	+175°C
S07*		F	+200°C*

* «S» Stand for 200°C compatibility. Omit for inserts with Quadrax contacts and differential Twinax contacts which are +175°C maxi compatible.

2. Standard low force option (receptacle)

Blank	For standard versions
L	Low force version - Consult us to confirm availability

3. Crimp contacts

R	Crimp contact
---	---------------

4. Material and platings

	Shell material	Shell finish
W	Aluminum	Olive drab cadmium
F		Nickel ✓

5. Insert arrangements

Refer to page 18 for contact arrangements. - JT / MIL-DTL-38999 Series II. First number represents the shell size and second number is the contact arrangement

6. Contact gender

P	Pin (500 cycles)
S	Socket (500 cycles)

7. Keying

Blank (for normal)	A	B
--------------------	---	---

8. With or without contacts

Blank	Connector delivered with contacts
LC	Connector delivered without contacts

All dimensions are given for information only and are in mm, except as otherwise specified | *in mm: 1mm=0.03937 inch

Series III TV-CTV
Series II JT
Series I LJT
Accessories & tools
Assembly instructions

MIL-DTL-SERIES II, JT - HOW TO ORDER - SC39LP - LOW PROFILE BREAKAWAY

Amphenol Designations - SC39LP PCB connectors

	1.	2.	3.	4.	5.	6.	7.	8.
Series	Shell type	Low force option	Material and platings	PC Tail contacts	Contact arrangement	Contact gender	Keying	Deviation
SC39LP	07	L	W	CI	12-35	P	A	F404

1. Shell type

	Shell type	Associated materials and platings	Temperature
00	Low profile Square flange receptacle	W	+175°C
S00*		F	+200° C*
07	Low profile Jam nut receptacle	W	+175°C
S07*		F	+200° C*

* «S» Stand for 200°C compatibility. Omit for inserts with Quadrax contacts and differential Twinax contacts Ⓞ which are +175°C maxi compatible.

2. Low force option

Blank	For standard versions
L	Low force version - Consult us to confirm availability

3. Material and platings

	Shell material	Shell finish
W	Aluminum	Olive drab cadmium
F		Nickel ✓

4. PC Tail contacts

CI	Standard length
-----------	-----------------

5. Contacts arrangements

Refer to page 18 for contact arrangements. - JT / MIL-DTL-38999 Series II.
First number represents the shell size and second number is the contact arrangement

6. Contact gender

P	Pin (500 cycles)
S	Socket (500 cycles)

Connectors with PC Tail contacts are always delivered with contacts.

7. Keying

Blank (for normal)	A	B
------------------------------	----------	----------

8. Deviation

Shell style	PC Tail finish / Tinning				Shell type compatibility
	Tin lead	Silver tin	Silver tin copper	Gold	
Standard	F404	F404LF ✓	F404LFC ✓	Blank ✓	All

For other deviations, please consult us.

Overall dimensions Square flange receptacle

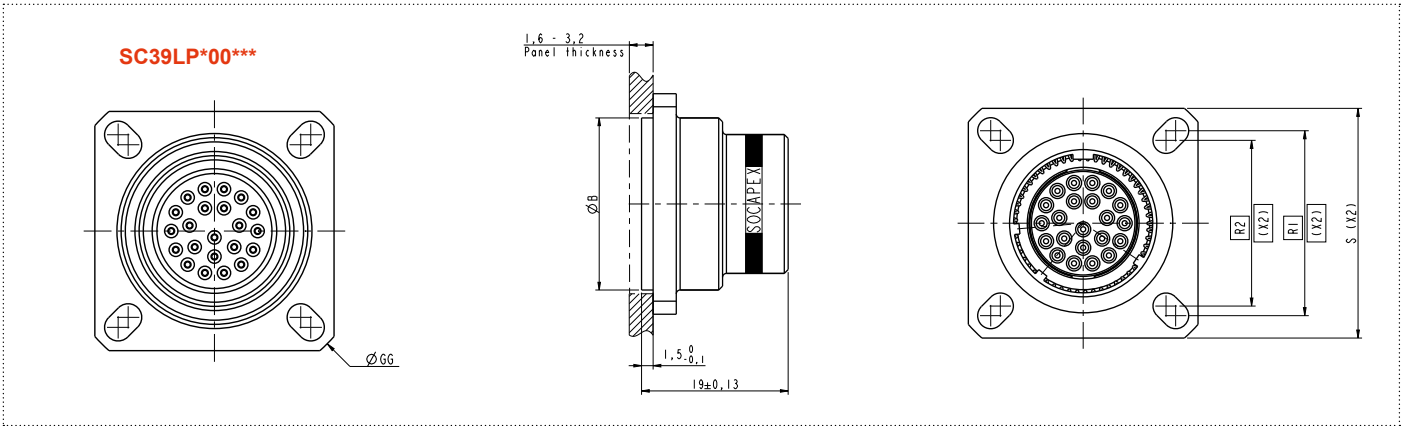

Size	ØA ⁰ _{-0.05}	R	S
8	15.03	18.26	15.09
10	19.15	20.62	18.26
12	22.32	23.01	20.6
14	25.28	24.61	23.01

✓ RoHS compliant

All dimensions are given for information only and are in mm, except as otherwise specified | *in mm: 1mm=0.03937 inch

MIL-DTL-SERIES II, JT DERIVED RANGE - SC39LP - LOW PROFILE BREAKAWAY

Jam nut receptacle

SC39LP*07***

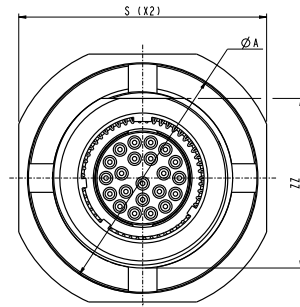
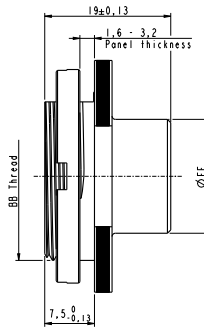
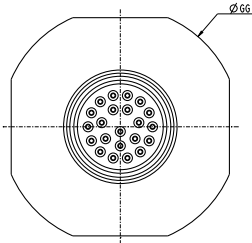

Size	ØEE ±0.1	S ±0.2	ØBB Thread	ØC ±0.3	ØH ⁰ -0.12	ZZ ^{+0.1} -0.15
8	11.03	27	.6875-24	30.2	24.51	16.53
10	14.18	31.78	.8125-20	34.96	27.45	19.07
12	17.20	34.96	1.0000-20	38.13	32.23	23.82
14	20.38	38.13	1.1250-18	41.3	35.25	26.87

Straight Plug

SC39LP*06***

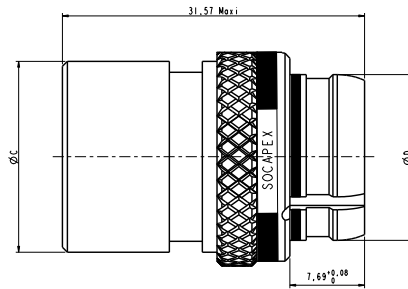
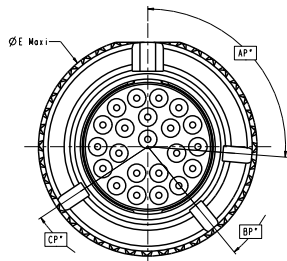

Size	ØE after knurling	ØD ⁰ -0.13	ØC ⁰ -0.13
8	15.03	11.13	13.54
10	19.53	14.38	15.37
12	22.53	17.23	19.66
14	27.03	20.40	21.29

All dimensions are given for information only and are in mm, except as otherwise specified | *in mm: 1mm=0.03937 inch

Series III TV-CTV
Series II JT
Series I LJT
Accessories & tools
Assembly instructions

MIL-DTL-SERIES II, JT DERIVED RANGE - SC39LP - LOW PROFILE BREAKAWAY

Panel Cutouts

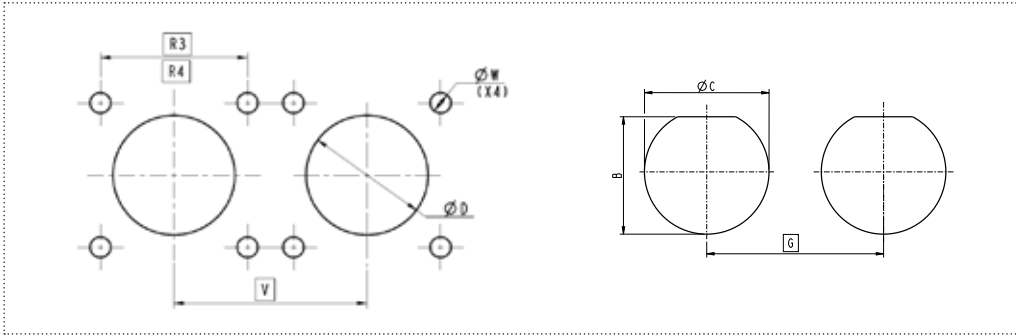

Size	R3	R4	V	ØD _{MIN}	ØW ⁺⁰ _{-0.25}	G	ØC ⁺⁰ _{-0.25}	B ⁺⁰ _{-0.25}
8	18.26	15.09	24.60	13.11	3.25	27.80	17.60	16.70
10	20.62	18.26	27.00	15.88		32.60	20.96	19.59
12	23.01	20.62	30.20	19.05		36.00	25.65	24.26
14	24.61	23.01	33.20	23.01		39.60	28.83	27.56

Keyway

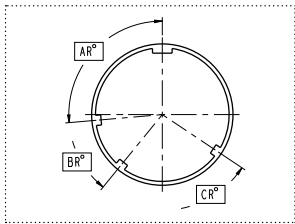

Size	Polarization	AP°	BP°	CP°
8	N	105	140	265
	A	102	132	320
	B	80	118	312
10 to 14	N	95	141	236
	A	113	156	292
	B	90	145	252

All dimensions are given for information only and are in mm, except as otherwise specified | *in mm: 1mm=0.03937 inch



MIL-DTL-38999 SERIES I/LJT



Table of contents

MIL-DTL-38999 Series I, LJT / STANDARD, EXTENDED & DERIVED RANGES	169
STANDARD RANGE - LJT SERIES	170
General characteristics	170
Technical characteristics	171
Electrical characteristics	172
LJT Series (MS27***, HE308)	175
EXTENDED RANGE	179
Stand-Off receptacle - F459	179
Integrated backshell - F472	180
Enhanced sealing receptacle - ETC ETCI ETLI	181
Thru-bulkhead receptacle (JMS/HE308)	183
DERIVED RANGE	185
RNJ - Rack and panel (HE308)	185
OPTICAL FIBER	198
LJT OP	198
RNJ OP - Rack and panel	201

THE SERIES I LJT SERVES VARIOUS MARKETS, INCLUDING:

Commercial Avionics
& AirframeMilitary Avionics
& Airframe

Military vehicles



C4ISR

Battlefield
communication

MIL-DTL-SERIES I, LJT - GENERAL CHARACTERISTICS

Bayonet coupling connectors designed for military and aerospace industries.

Description

Amphenol Socapex is a MIL-DTL-38999 Series I QPL and HE308 qualified manufacturer. The LJT product range was developed to meet the needs of the aerospace and military industries. It offers bayonet coupling connectors with a large variety of contact arrangements and shell types, maximum weight / space saving and a 100 % contact protection.



Main features

SHELL MATERIAL

- Aluminium alloy.
- Marine bronze available - ✓ RoHS compliant.

PLATINGS

- Olive drab cadmium plating.
- Electroless nickel plating - ✓ RoHS compliant.
- Black zinc nickel plating - ✓ RoHS compliant.
- For other platings, please consult us.

9 SHELL SIZES FROM 09 TO 25

EMI/RFI PROTECTION

- Grounding fingers on the plug shell.
- Grounded versions available [ⓐ].

CONTACTS

- More than 60 contacts arrangements high-speed and power possibilities.
- Size 4/0, 2/0, 4, 8, 12, 16, 20, 22 contacts.
- Signal, Power, Coax, Twinax, Optical termini, Quadrax and differential Twinax possibilities;
- Crimp and PC-Tail terminations (Tin and Lead-free finishes available for PCB contacts)

CONTACT PROTECTION

- 100 % scoop-proof shell.
- Improved interfacial seal ensuring sealing around each contact and preventing electrolytic erosion.

Concept

- 1 Socket insert
- 2 Grommet
- 3 Crimping socket contact
- 4 Grounding fingers (EMI)
- 5 Interfacial seal
- 6 Crimping pin contact
- 7 Pin insert
- 8 Sealing
- 9 Contact retention clips
- 10 Receptacle seal

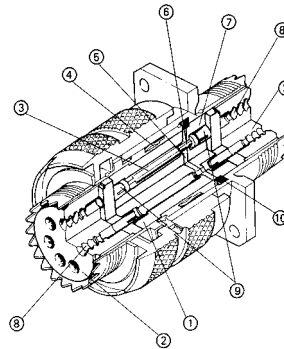

Materials and platings

	Material	Plating	Benefit
Shell	Aluminum	Olive drab cadmium, Nickel, Black zinc nickel	Robust standard material
	Marine bronze	-	Corrosion resistance: up to 1000 hours salt spray exposure Robustness for marine applications
Insert	Thermoplastic	-	
Grommet and interfacial seal	Fluorosilicone	-	
Contact	Copper alloy	Gold, tin, silver tin, silver tin copper	

[ⓐ] Ground plane proprietary option available (metal insert for use with Coaxial, Twinax or Quadrax contacts). Please consult us for socket version

[ⓑ] High density 38999, Quadrax and differential Twinax arrangements not rated over 175°C

All dimensions are given for information only and are in mm, except as otherwise specified | *in mm: 1mm=0.03937 inch

MIL-DTL-SERIES I, LJT - TECHNICAL CHARACTERISTICS

Materials characteristics

	Shell material	Shell finish	Salt spray exposure per EIA 364.26 (hours)	Class norm	Amphenol designation	Operating temperature (°C)	
						Min	Max
Waterproof (IP X7)	Aluminum	Olive drab cadmium	500	B	LJT** 014	- 65	+ 175
		Nickel	48	F	LJT** 023	- 65	+ 200 ^{HD}
		Black zinc nickel	96	-	LJT** 033K	- 65	+ 175
	Marine bronze	-	1000	-	LJT** RB**	- 65	+ 200 ^{HD}

Mechanical characteristics

Characteristics	MIL-DTL-38999																
Durability	500 cycles																
Shock	Half sine wave of 300 G magnitude during 3ms per EIA-364-27																
Vibration	Sine vibrations: - 60g from -55° to +175° (Olive drab cadmium and Black zinc nickel) - 60g from -55° to +200° (Nickel and Stainless steel) Random vibrations: per EIA-364-28: - 43.92 grms at 175°C (Olive drab cadmium and Black zinc nickel), 50 to 2000 Hz - 43.92 grms at 200°C (Nickel and Stainless steel), 50 to 2000 Hz - 50.09 grms at ambient air Consult us for Durmalon (Nickel PTFE) and Green Zinc cobalt																
Contact retention force	<table border="1"> <thead> <tr> <th>Size</th> <th>22D</th> <th>20</th> <th>16</th> <th>12</th> <th>8</th> <th>4</th> <th>00</th> </tr> </thead> <tbody> <tr> <td>Max load (N)</td> <td>45</td> <td>67</td> <td>110</td> <td>110</td> <td>150</td> <td>150</td> <td>150</td> </tr> </tbody> </table>	Size	22D	20	16	12	8	4	00	Max load (N)	45	67	110	110	150	150	150
Size	22D	20	16	12	8	4	00										
Max load (N)	45	67	110	110	150	150	150										

Environmental characteristics

Characteristics	MIL-DTL-38999. M version. Amendment 2
Humidity	§3.29
Air leakage	§3.10.
Fluid immersion	Per EIA 364.10 : - Hydraulic fluid, per MIL-H-5606. - Turbine fluid, grade JP-8, per MIL-DTL-83133 (NATO TYPE 34). - Lubricating oil, per MIL-L-7808. - Lubricating oil, per MIL-PRF-23699. - Defrosting fluid, per MIL-A-8243. - Cleaning compound, diluted for cleaning, per MIL-PRF-87937 type I alkaline base. - Gasoline, per ASTM-D-4814.- Gasohol, per A-A-52530. - One part isopropyl alcohol, per TT-I-735, grade A or B ; and 3 parts mineral spirits, per A-A-2904, type II, grade A or P-D-680, type I, by volume. - Coolant, dielectric fluid, synthetic silicate ester base MIL-PRF-47220 (Coolanol 25) or equivalent. - Hydraulic fluid M2-V Chevron oil ST0145LB0001 or equivalent;

Keyway position

A plug with a given rotation letter will mate with a receptacle with the same rotation letter. The angles for a given connector are the same whether it contains pins or sockets. Master key stays fixed, minor keys rotate. Inserts are not rotated in conjunction with the master key/keyway.

Shell Size	Normal	References			
		A	B	C	D
9	95°	77°	-	-	113°
11	95°	81°	67°	123°	109°
13	95°	75°	63°	127°	115°
15	95°	74°	61°	129°	116°
17	95°	77°	65°	125°	113°
19	95°	77°	65°	125°	113°
21	95°	77°	65°	125°	113°
23	95°	80°	69°	121°	110°
25	95°	80°	69°	121°	110°

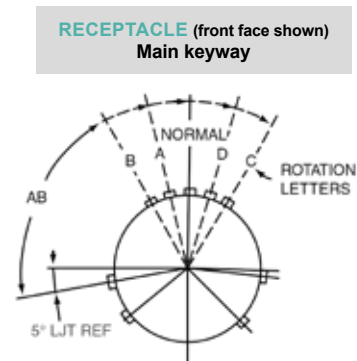

^{HD} High density 38999, Quadrax and differential Twinax arrangements not rated over 175°C
 All dimensions are given for information only and are in mm, except as otherwise specified | *in mm: 1mm=0.03937 inch

MIL-DTL-SERIES I, LJT - ELECTRICAL CHARACTERISTICS

Service rating

Service rating	Dielectric withstanding voltage (Vrms)								Working voltage	
	At sea level		15 000 meters		21 000 meters		34 000 meters		Vms	Vdc
	Mated	Unmated	Mated	Unmated	Mated	Unmated	Mated	Unmated		
M	1300	1300	800	550	800	350	800	200	400	550
I	1800	1800	1000	600	1000	400	1000	200	600	850
II	2300	2300	1000	800	1000	500	1000	200	900	1250

Contacts and cables

For more information about contacts, please refer to the dedicated "Contacts" catalog DOC-000081-ANG

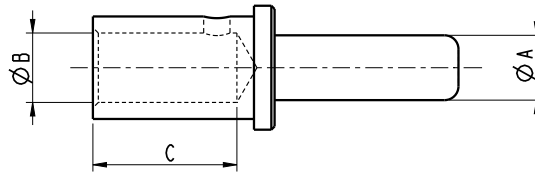

Contact characteristics

	Contact termination	22D	20	16	12	8 **	4 **	00
Contact rating (nominal current per contact, A) at ambient temperature	Crimp barrel	5	7.5	13	23	60	100	230 *
	PC tail	3	4.5	10	17	40		
	Hermetic	3	5	10	17			
Contact resistance (without wire, mΩ)		8	4.7	2	1.1	0.6	0.26	0.102
Insulation resistance (MΩ)	> 5.10 ³ at ambient temperature > 1.10 ³ at maximum temperature							
ØA Pin contact diameter (mm) (mating area)		0.76	1	1.57	2.36	3.60	5.70	12.0
Crimp barrel	ØB Diameter (mm)	0.88 ± 0.03	1.19 ± 0.03	1.70 ± 0.03	2.54 ± 0.06	4.6 ± 0.05	7.4 ± 0.05	14.6
	C Depth (mm)	3.58	5.30	5.30	10	10	12	21
Cable dimensions (Section in mm ²)	American wire gauge AWG							
	28	0.095						
	26	0.15						
	24		0.22					
	22		0.38					
	20			0.60				
	18			0.93				
	16			1.34				
	14				1.94			
	12				3.30			
8 **						8.98-10 _{MAX}		
4 **							21.10 ▲	
00								100
Outside diameter (mm)	MIN	0.76	1.02	1.68	2.46	4.50	7.73	13.30
	Average	1.20	1.83	2.41	3.20			
	MAX	1.37	2.11	2.77	3.61	5.20	8.40	14.70

* 185A according to AS39029 standard. 230A only for 23-P1 arrangement with Radsok technology

** Consult us for other cable dimensions

▲ Concentric wire only (contacts 900007 & 900047). For others cables types consult us.

HD High density 38999, Quadrax and differential Twinax arrangements not rated over 175°C

All dimensions are given for information only and are in mm, except as otherwise specified | *in mm: 1mm=0.03937 inch

MIL-DTL-SERIES I, LJT - HOW TO ORDER - LJT

Military Designations - DLA MIL-DTL-38999 SERIES I Connectors

	1.	2.	3.	4.	5.	6.	7.
Series	Shell type	Crimp contacts	Shell size	Material and plating	Contact arrangement	With or without contact	Keying
MS27	467	T	15	B	35	P	A

1. Shell type

466	Receptacles	Square flange receptacle, wall mounting
656		Square flange receptacle, wall mounting (back panel mount)
468		Jam nut receptacle
467	Plugs	Straight plug

2. Crimp contacts

T	Crimp contacts
---	----------------

3. Shell size

09	11	13	15	17	19	21	23	25
----	----	----	----	----	----	----	----	----

4. Material and platings (metallic shells only)

	Shell material	Shell finish
B	Aluminum	Olive drab cadmium
F		Nickel ✓

5. Contact arrangement

Refer to page 18 for contact arrangements - LJT / MIL-DTL-38999 Series I.
Only take the second number of the insert arrangement which is the contact arrangement.

6. With or without contact

P	Pin (500 cycles)
S	Socket (500 cycles)
A	Without pin contacts
B	Without socket contacts

7. Keying

Blank (for normal)	A	B	C	D
-----------------------	---	---	---	---

Refer to page 28 for keying information.

Military Designations - HE308 - UTE 93422 Connectors

	1.	2.	3.	4.	5.	6.	7.
Series	Shell type	Crimp contact	Contacts arrangement	Contact gender	Keying	Material and platings	With or without contact
HE308	07	T	15-35	P	N	7M	-

1. Shell type

00	Receptacle	Square flange receptacle - Crimp contacts
01		Inline receptacle - Crimp contacts
07		Jam nut receptacle - Crimp contacts
11		Jam nut receptacle - PC Tail contacts
06	Plug	Straight plug, crimp contacts

2. Crimp contact

T	Crimp contacts (except for shell type 11: PC Tail contacts)
---	---

3. Contacts arrangement

Refer to page 18 for contact arrangements - HE308.
First number represents the shell size and second number is the contact arrangement.

4. Contact gender

P	Pin (500 cycles)
S	Socket (500 cycles)

5. Keying

N (for normal)	A	B	C	D
-------------------	---	---	---	---

Refer to page 28 for keying information.

6. Material and platings (metallic shells only)

	Shell material	Shell finish
7M	Aluminum	Olive drab cadmium
6M		Nickel ✓

7. With or without contacts

Blank	Connector delivered with contacts
LC	Connector delivered without contact

Jam nut receptacle with PC Tail contacts (shell type 11) are always delivered with contacts.

✓: RoHS compliant
All dimensions are given for information only and are in mm, except as otherwise specified | *in mm: 1mm=0.03937 inch

MIL-DTL-SERIES I, LJT - HOW TO ORDER - LJT

Amphenol Designations - LJT Crimp connectors

	1.	2.	3.	4.	5.	6.	7.	8.
Series	Shell type	Crimp contact	Contact arrangement	Contact gender	Keying	Material and platings	With or without contact	Deviation
LJT	07	RT	15-35	P	A	014	-	-

1. Shell type

Code	Description	Shell type
00	Receptacle	Square flange receptacle (wall mount)
PQ00		Square flange receptacle (wall mount back panel)
01		Inline receptacle
07	Plug	Jam nut receptacle
06		Straight plug

2. Crimp contact

RT	Crimp contacts
----	----------------

3. Contacts arrangements

Refer to page 18 for contact arrangements - LJT / MIL-DTL-38999 Series I. First number represents the shell size and second number is the contact arrangement.

4. Contact gender

P	Pin (500 cycles)
S	Socket (500 cycles)

5. Keying

Blank (for normal)	A	B	C	D
Refer to page 28 for keying information.				

6. Material and platings

Code	Shell material	Shell finish
014	Aluminum	Olive drab cadmium
023		Nickel ✓
033K		Black zinc nickel ✓

7. With or without contacts

Blank	Connector delivered with contacts
LC	Connector delivered without contact

8. Deviation

Code	Description	Shell type
F472	Integrated backshell – band-it width 8mm ±0.2	All shell styles
F506	Receptacle equipped with clinch nuts	PQ00

For other deviations, please consult us.

Amphenol Designations - LJT PCB Receptacles

	1.	2.	3.	4.	5.	6.	7.
Series	Shell type	PC Tail contact	Contact arrangement	Contact gender	Keying	Material and platings	Deviation
LJT	07	CI	09-98	P	-	014	-

1. Shell type (receptacles only)

00	Square flange receptacle (wall mount)
PQ00	Square flange receptacle (wall mount back panel)
07	Jam nut receptacle

2. PC tail contact

CI	Standard length
LI	Long length

3. Contacts arrangements

Refer to page 18 for contact arrangements - LJT / MIL-DTL-38999 Series I. First number represents the shell size and second number is the contact arrangement.

4. Contact gender

P	Pin (500 cycles)
S	Socket (500 cycles)

5. Keying

Blank (for normal)	A	B	C	D
Refer to page 28 for keying information.				

6. Material and platings

Code	Shell material	Shell finish
014	Aluminum	Olive drab cadmium
023		Nickel ✓
033K		Black zinc nickel ✓

7. Deviation

Shell style	PC Tail finish / Tinning				Shell type compatibility
	Tin lead	Silver tin	Silver tin copper	Gold	
Standard	F404	F404LF ✓	F404LFC ✓	Blank ✓	All
Equipped with clinch nuts	F506G	F506LF	F506LFC	F506	LJTPQ00
Stand-off	F459	F459LF	F459LFC	F459H	All

For other deviations, please consult us.

✓: RoHS compliant

All dimensions are given for information only and are in mm, except as otherwise specified | *in mm: 1mm=0.03937 inch

MIL-DTL-SERIES I, LJT - OVERALL DIMENSIONS

Overall Dimensions Square Flange - Wall mount receptacle



LJT 00 RT / HE308 00 T / MS27466 T

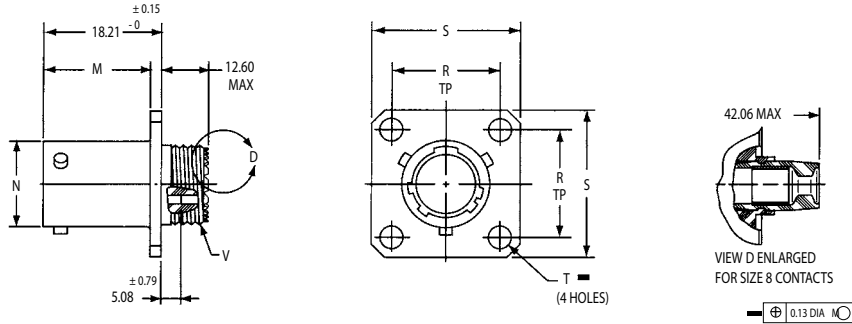

Shell size	M ^{+0/-0.13}	N ^{+0.03/-0.13}	R (TP)	S ^{±0.41}	ØT ^{±0.13}	V Thread Class 2A (plated)
9	16.05	14.53	18.26	23.83	3.25	.4375-28 UNEF
11	16.05	17.78	20.62	26.19	3.25	.5625-24 UNEF
13	16.05	21.59	23.01	28.58	3.25	.6875-24 UNEF
15	16.05	24.77	24.61	30.96	3.25	.8125-20 UNEF
17	16.05	27.94	26.97	33.32	3.25	.9375-20 UNEF
19	16.05	30.66	29.36	36.53	3.25	1.0625-18 UNEF
21	15.29	33.83	31.75	39.67	3.25	1.1875-18 UNEF
23	15.29	37.01	34.92	42.88	3.73	1.3125-18 UNEF
25	15.29	40.18	38.10	46.03	3.73	1.4375-18 UNEF

Square Flange - Wall mount receptacle (Back panel mounting)



LJT PQ00 RT / MS27656 T

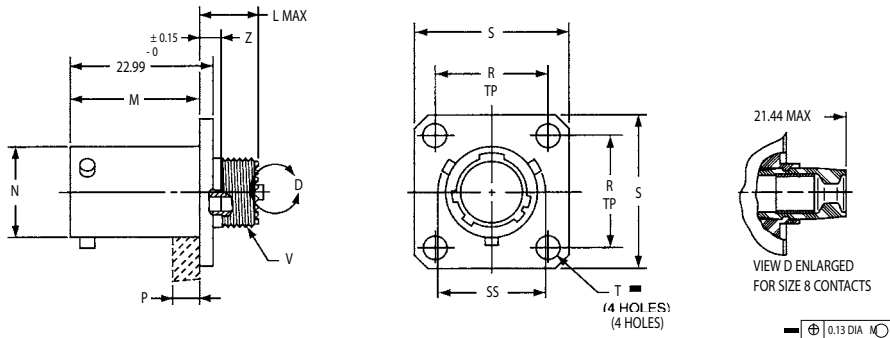

Shell size	L _{MAX}	M ^{+0/-0.13}	ØN	P _{MAX} Panel Thickness	R (TP)	S ^{+0.28/-0.25}	ØT ^{±0.13}	V thread Class 2A (plated)	Z _{MAX}
9	11.51	20.83	14.53	5.94	18.26	23.83	3.25	.4375-28 UNEF	3.50
11	11.51	20.83	17.78	5.94	20.62	26.19	3.25	.5625-24 UNEF	3.50
13	11.51	20.83	21.59	5.94	23.01	28.58	3.25	.6875-24 UNEF	3.50
15	11.51	20.83	24.77	5.94	24.61	30.96	3.25	.8125-20 UNEF	3.50
17	11.51	20.83	27.94	5.94	26.97	33.32	3.25	.9375-20 UNEF	3.50
19	11.51	20.83	30.66	5.94	29.36	36.53	3.25	1.0625-18 UNEF	3.50
21	12.29	20.07	33.83	5.18	31.75	39.67	3.25	1.1875-18 UNEF	4.27
23	12.29	20.07	37.01	5.18	34.92	42.88	3.73	1.3125-18 UNEF	4.27
25	12.29	20.07	40.18	4.90	38.10	46.03	3.73	1.4375-18 UNEF	4.27

All dimensions are given for information only and are in mm, except as otherwise specified | *in mm: 1mm=0.03937 inch

MIL-DTL-SERIES I, LJT - OVERALL DIMENSIONS

Jam nut receptacle



LJT 07 RT / HE308 07 T / MS27468 T

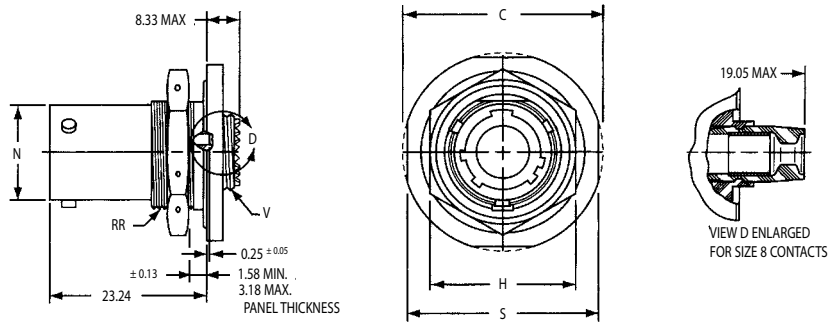

Shell size	C _{MAX}	H Hex ^{+0.43} / _{-0.41}	N ^{+0.03} / _{-0.13}	S ^{±0.41}	V thread Class 2A (plated)	RR Thread Class 2A (plated)	Hex. nut min/max torque value (N.m)
9	30.46	22.00	14.53	26.97	.4375-28 UNEF	.6875-24 UNEF	3.4 / 4.1
11	35.20	25.40	17.78	31.75	.5625-24 UNEF	.8125-20 UNEF	4.5 / 5.2
13	38.38	30.00	21.59	34.92	.6875-24 UNEF	1.0000-20 UNEF	6.2 / 6.8
15	41.55	33.00	24.77	38.10	.8125-20 UNEF	1.1250-18 UNEF	7.9 / 8.5
17	44.73	37.00	27.94	41.27	.9375-20 UNEF	1.2500-18 UNEF	9.0 / 9.6
19	49.51	40.00	30.66	46.02	1.0625-18 UNEF	1.3750-18 UNEF	10.2 / 10.7
21	52.65	43.00	33.83	49.23	1.1875-18 UNEF	1.5000-18 UNEF	11.3 / 12.4
23	55.86	46.00	37.01	52.37	1.3125-18 UNEF	1.6250-18 UNEF	12.4 / 13.6
25	59.13	51.20	40.18	55.58	1.4375-18 UNEF	1.7500-18 UNEF	13.6 / 14.7

In-line receptacle



LJT 01 RT / HE308 01 T

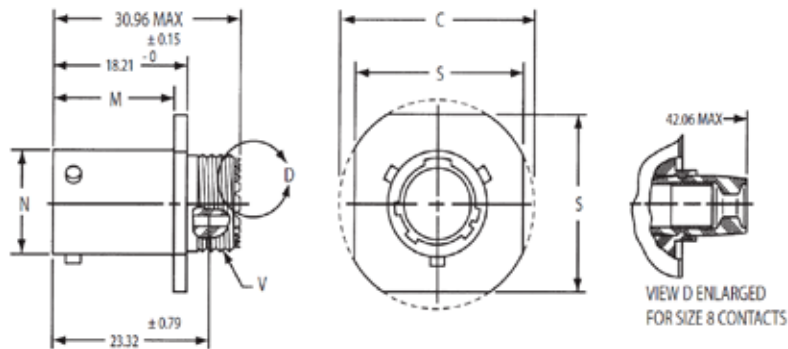

Shell size	C _{MAX}	M ⁺⁰ / _{-0.13}	N ^{+0.03} / _{-0.13}	S ^{±0.41}	V thread Class 2A (plated)
9	27.79	16.05	14.53	23.83	.4375-28 UNEF
11	30.18	16.05	17.78	26.19	.5625-24 UNEF
13	32.54	16.05	21.59	28.58	.6875-24 UNEF
15	34.93	16.05	24.77	30.96	.8125-20 UNEF
17	37.31	16.05	27.94	33.32	.9375-20 UNEF
19	40.49	16.05	30.66	36.53	1.0625-18 UNEF
21	43.66	15.29	33.83	39.67	1.1875-18 UNEF
23	46.84	15.29	37.01	42.88	1.3125-18 UNEF
25	50.01	15.29	40.18	46.03	1.4375-18 UNEF

All dimensions are given for information only and are in mm, except as otherwise specified | *in mm: 1mm=0.03937 inch

Series III TVCTV
Series II JT
Series I LJT
Accessories & tools
Assembly instructions

MIL-DTL-SERIES I, LJT - OVERALL DIMENSIONS

Straight plug



LJT 06 RT / HE308 06 T / MS27467 T

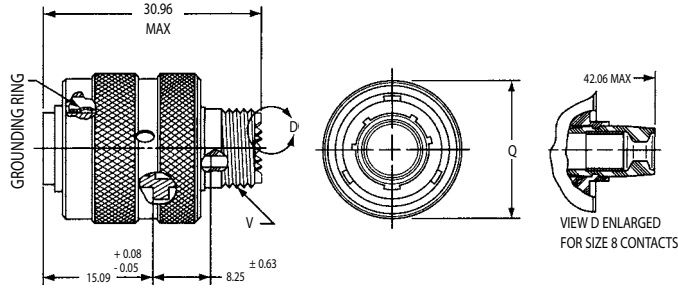

Shell size	Q _{MAX}	V Thread Class 2A
9	21.44	.4375-28 UNEF
11	24.61	.5625-24 UNEF
13	28.98	.6875-24 UNEF
15	32.16	.8125-20 UNEF
17	35.33	.9375-20 UNEF
19	38.10	1.0625-18 UNEF
21	41.28	1.1875-18 UNEF
23	44.45	1.3125-18 UNEF
25	47.63	1.4375-18 UNEF

Panel Cutouts

LJT PQ00
Square flange receptacle
Back panel mounting

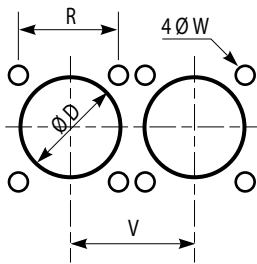

LJT 00
Square flange receptacle
Front panel mounting

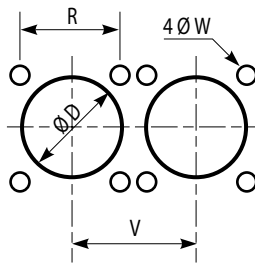

LJT 07
Jam nut receptacle
Back panel mounting

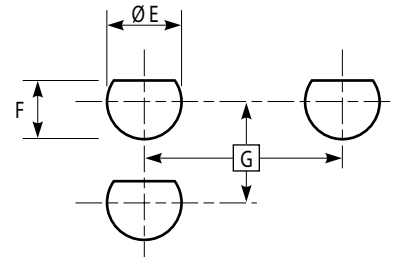

Shell size	R	V ⁺⁰ _{-0.25}	W ⁺⁰ _{-0.25}	G _{MIN}	E _{MIN}	F ⁺⁰ _{-0.25}	B ⁺⁰ _{-0.41}	D ⁺⁰ _{-0.25}
9	18.26	24.60	3.25	27.80	17.70	16.99	16.81	13.11
11	20.62	27.00	3.25	32.60	20.88	19.53	20.57	15.88
13	23.01	30.20	3.25	36.00	25.58	24.26	24.38	19.05
15	24.61	33.30	3.25	39.60	28.80	27.53	27.56	23.01
17	26.97	36.50	3.25	43.30	31.98	30.68	30.73	25.81
19	29.36	39.30	3.25	47.00	35.16	33.86	33.45	28.98
21	31.75	42.50	3.25	50.60	38.28	37.06	36.53	32.16
23	34.93	45.70	3.73	54.20	41.50	40.01	39.30	34.93
25	38.10	48.80	3.73	59.70	44.68	43.41	42.98	37.69

All dimensions are given for information only and are in mm, except as otherwise specified | *in mm: 1mm=0.03937 inch

MIL-DTL-SERIES I, LJT - OVERALL DIMENSIONS - PC-TAILS RECEPTACLE

PC-Tail lengths - LJT Receptacles (MIL-DTL-38999 Series I)

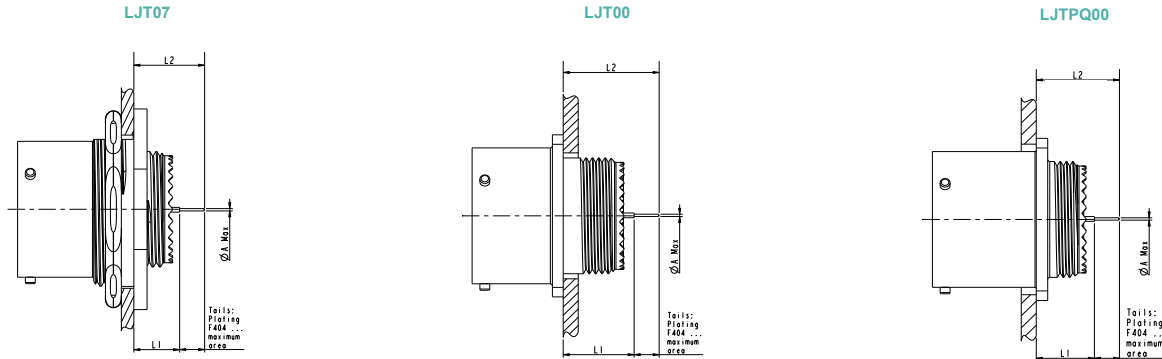

		CI (5 mm contact length)				LI (8.5 mm contact length)					
		LJT 07 CI		LJT 00 CI		LJT 07 LI		LJT 00 LI		LJT PQ00 LI	
		9 to 25	9 to 25	9 to 19	21 to 25	9 to 25	9 to 25	9 to 19	21 to 25		
Pin	L1	MIN	8.73	13.76	11.28	12.04	8.73	13.76	11.28	12.04	
		MAX	9.70	14.60	12.11	12.87	9.70	14.60	12.11	12.87	
	L2	MIN	13.63	18.66	16.18	16.94	17.13	22.16	19.68	20.44	
		MAX	14.80	19.70	17.21	17.97	18.30	23.20	20.71	21.47	
Socket	L1	MIN	8.53	13.56	11.08	11.84	8.53	13.56	11.08	11.84	
		MAX	9.50	14.40	11.91	12.67	9.50	14.40	11.91	12.67	
	L2	MIN	13.43	18.46	15.98	16.74	16.93	21.96	19.48	20.24	
		MAX	14.60	19.50	17.01	17.77	18.10	23.00	20.51	21.27	

Contact size	Ø A Max			
	CI (5mm contact length)		LI (8.5 mm contact length)	
	Gold plated contacts	Tin lead. Silver tin or Silver tin copper plated contacts	Gold plated contacts	Tin lead. Silver tin or Silver tin copper plated contacts
22	0.5	0.6	0.7	0.8
20	0.7	0.8	0.7	0.8
16	1.15	1.25	1.15	1.25
12	1.7	1.8	1.7	1.8

All dimensions are given for information only and are in mm, except as otherwise specified | *in mm: 1mm=0.03937 inch

MIL-DTL-SERIES I, LJT EXTENDED RANGE - STAND-OFF RECEPTACLE

Double flange receptacles for PC tail applications.



Description

Double Flange receptacles for PC tail applications, to avoid stress on contact terminations while providing grounding continuity between the PCB & the box.

Main features

- Receptacles with stand-off flange shells. for attachment to printed circuit boards.
- Prevent mechanical stress on the contact terminations.
- Provide grounding continuity between the PCB and the box.
- Increase reliability and resistance to shocks and vibrations.

OPTIONS:

- Square Flange - Wall mount (LJT PQ00) or Jam nut (LJT 07) shells.
- Tin plated or Lead free (tin-silver or tin-silver-copper) contacts available.

AMPHENOL	DEVIATIONS
Lead tinned stand off	F459
Silver tinned stand off	F459LF
Silver copper tinned stand off	F459LFC

Overall dimensions

Jam nut receptacle

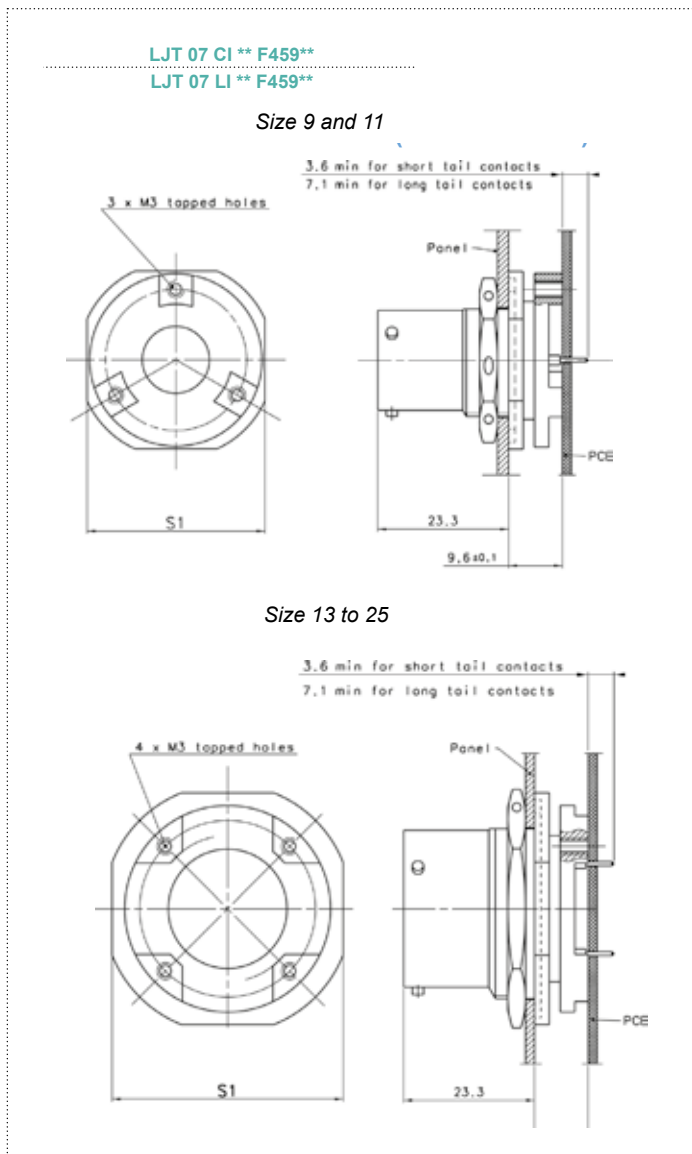

Square Flange - Wall Mount receptacle

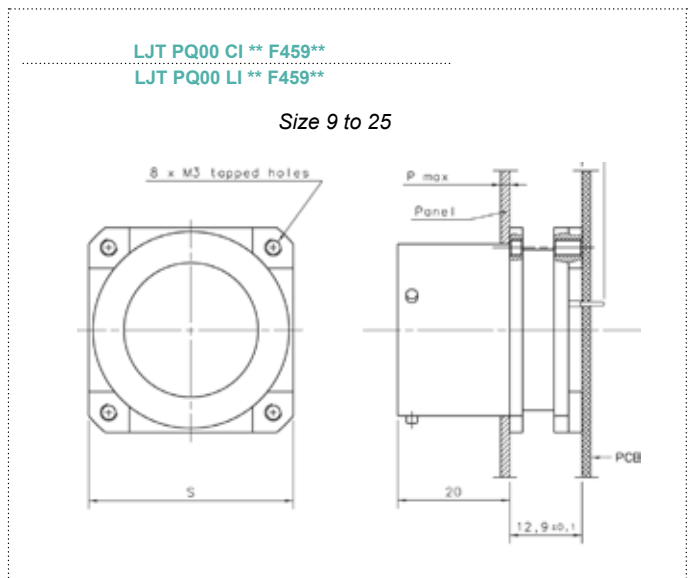

Shell size	S ±0.25	P MAX	S1 ±0.4
9	23.82	5.18	27.00
11	26.19	5.18	31.80
13	28.57	5.18	34.90
15	30.96	5.18	38.10
17	33.32	5.18	41.30
19	36.52	5.18	46.00
21	39.67	5.18	49.20
23	42.87	5.18	52.40
25	46.02	4.90	55.60

All dimensions are given for information only and are in mm, except as otherwise specified | *in mm: 1mm=0.03937 inch

MIL-DTL-SERIES I, LJT EXTENDED RANGE - INTEGRATED BACKSHELL

All-in-one 38999 Series I connectors with an integrated backshell



Description

Available on plugs and receptacles, lightweight and low profile solutions offering EMI performances.

Main features

- All-in-one product : time saving during order and installation
- High EMI Protection
- Quick, easy, cost effective cabling process
- Braid campling (micro and macro Band-it)

OPTIONS:

- Aluminum or Marine bronze shells.
- Straight plugs, Jam nut or In-line receptacles

AMPHENOL	DEVIATION
Integrated Backshell	F472

Overall dimensions

Jam nut receptacle

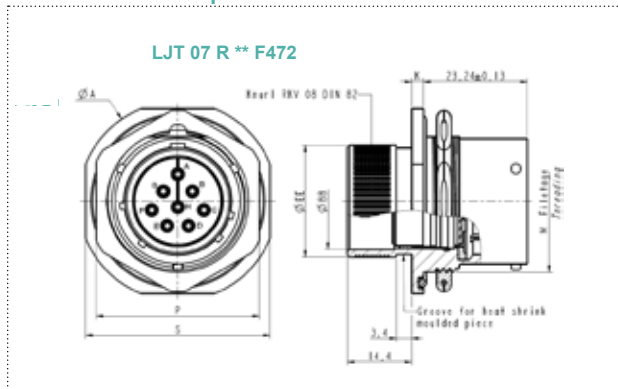

Shell size	S ±0.41	ØA ±0.41	K ⁺⁰ / _{-0.25}	P ±0.43	ØBB	ØE _{MAX}	M Threading Class 2A UNEF (inch)
9	26.97	30.18	2.77	22.23	9.0	12	.6875-24
11	31.75	34.93		25.4	12.2	15	.8125-20
13	34.93	38.1		30.18	15.1	18	1.0000-20
15	38.10	41.28		33.32	18.3	22	1.1250-18
17	41.28	44.45		36.53	21.5	25	1.2500-18
19	46.02	49.23	3.56	39.67	24.2	28	1.3750-18
21	49.23	52.37		42.88	27.3	31	1.5000-18
23	52.37	55.58		46.02	30.5	34	1.6250-18
25	55.58	58.72		50.8	33.7	37	1.7500-18

In-line receptacle

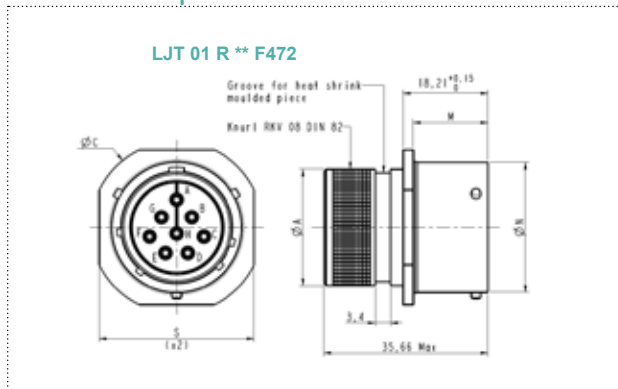

Shell size	ØC ±0.3	ØN ⁺⁰ / _{-0.13}	M ⁺⁰ / _{-0.13}	S ±0.41	ØA ⁺⁰ / _{-0.13}
9	27.49	14.53	16.05	23.83	12
11	29.88	17.78		26.19	15
13	32.24	21.59		28.58	18
15	34.63	24.77		30.96	22
17	37.01	27.94		33.32	25
19	40.19	36.66	15.29	36.53	28
21	43.36	33.83		39.67	31
23	46.54	37.01		42.88	34
25	49.71	40.18		46.03	37

Straight plug

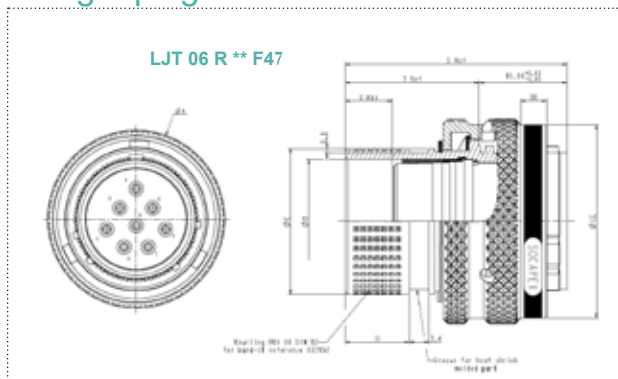

Shell size	ØA _{MAX}	ØB	ØCC ⁺⁰ / _{-0.13}	DD ⁺⁰ / _{-0.13}	OE ⁺⁰ / _{-0.13}	S	T ref	U max
9	21.82	8.74	19.81	4.06	12	38.09	23	8.5
11	24.99	11.99	22.99		15			
13	29.36	14.88	26.95		18			
15	32.54	18.06	30.12		22			
17	35.71	21.23	33.05		25			
19	38.51	23.93	36.12	30.12	26.95			
21	41.68	27.10	39.22		30.12			
23	43.86	30.28	42.34		33.30			
25	48.03	33.45	45.54		36.47			
						40.09	25	10.5

All dimensions are given for information only and are in mm, except as otherwise specified | *in mm: 1mm=0.03937 inch

MIL-DTL-SERIES I, LJT EXTENDED RANGE - ENHANCED SEALING

Helium leakage limited to 1.10^{-6}cm^3 per second.



Description

LJT07*ETC*** / ETCI*** / ETLI*** receptacles with enhanced sealing are derived from the standard MIL-DTL-38999 Series I Jam nut receptacles. The inserts have been modified to ensure an air leakage of $< 1.10^{-6} \text{cm}^3/\text{s}$ under 1 bar of differential pressure.

Main features

- Receptacles with enhanced sealing – interchangeable with MIL-DTL-38999 Series I plugs.
- Available on standard signals arrangements with solder cup or PC tails pin contacts.
- Operating Temperature range: -55 / +125°C.
- Initial sealing performance: Helium leakage $< 1.10^{-6} \text{cm}^3/\text{s}$ under 1 bar of differential pressure.
- Designed for unpressurized area.
- Avoid any stress on contacts before, during and after wave or iron soldering process.
- With Stand-off shells, shells must be threaded onto the PC Board before any soldering.
- We advise to use HFE cleaning product and strongly not recommend any Vigon based one.

CONTACTS TERMINATIONS	DEVIATION
Solder Cup contacts	ETC
PC Tail - Standard Length	ETCI
PC Tail - Long Length	ETLI

Amphenol Designations - LJT Receptacles with enhanced sealing

1.	2.	3.	4.	5.	6.	
Series	Shell type	Contact type	Contact arrangement	Contact gender	Keying	Material and platings
LJT	07	ETC	15-35	P	-	014

1. Shell type

07 Jam nut receptacle

2. Contact type

- ETCI PC-Tail contacts - Standard length
- ETLI PC-Tail contacts - Long length
- ETC Solder contacts - Standard length

3. Contact arrangement

Refer to page 18 for contact arrangements - LJT / MIL-DTL-38999 Series I.
First number represents the shell size and second number is the contact arrangement.

4. Contact gender

- P Pin (500 cycles)
- S Socket (500 cycles)

Enhanced sealing connectors are always delivered with contacts.

5. Keying

N (for normal) A B C D

Refer to page 28 for keying information.

6. Material and platings

	Shell material	Shell finish
014		Olive drab cadmium
023	Aluminum	Nickel ✓
033K		Black zinc nickel ✓

For specific shells, please consult us.

All dimensions are given for information only and are in mm, except as otherwise specified | *in mm: 1mm=0.03937 inch

MIL-DTL-SERIES I, LJT EXTENDED RANGE - ENHANCED SEALING

Overall dimensions Jam nut receptacle

LJT 07*ETC*
LJT 07*ETCI
LJT 07*ETLI*

ETC version

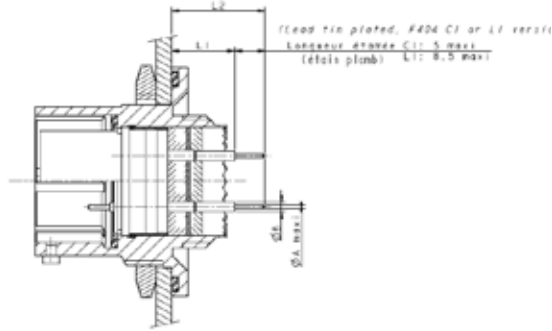

ETCI/ETLI version

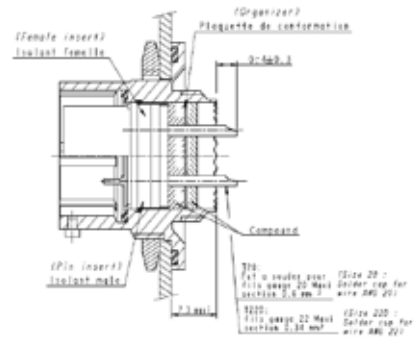

Solder cup						
Size	23	22D	20	16	12	8
Wire AWG MAX	22	22	20	16	12	8
Section mm ²	0.38	0.38	0.6	1.34	1.94	10

PCB contact (CI)						
Size	23	22D	20	16	12	
ØA _{MAX}	Gold	0.5	0.5	0.7	1.15	1.7
	Tinned	0.6	0.6	0.8	1.25	1.8
ØB	1	1	1.5	2.2	3	

Contact	Connector size	
	9 to 25	
Socket CI	L1	8.5 to 9.5
	L2	13.4 to 14.6
Socket LI	L1	8.5 to 9.5
	L2	16.9 to 18.1
Pin CI	L1	8.7 to 9.7
	L2	16.6 to 14.8
Pin LI	L1	8.7 to 9.7
	L2	17.1 to 18.3

All dimensions are given for information only and are in mm, except as otherwise specified | *in mm: 1mm=0.03937 inch

MIL-DTL-SERIES I, LJT EXTENDED RANGE - THRU-BULKHEAD

Receptacles using 38999 inserts dedicated to through bulkhead applications.

Description

LJTB / HE308 0BT connectors are dedicated to feed through of circuits on bulkhead or panels in harsh environments.



Main features

- Intermateable with MIL-DTL-38999 Series I plugs.
- Available in 8 shells sizes (11 to 25)
- Aluminum shells with OD. Cadmium or , Nickel or Black Zinc Nickel plating.
- Pin and socket double ended contacts.
- Interfacial seal on male side.
- Polarization possibility: Normal, A, B, C and D.

How to order

Military Designations - UTE 93422 Thru-bulkhead receptacles

1.	2.	3.	4.
Series	Contacts arrangement	Contact gender	Keying
HE308 0BT	17-06	PS	N
Material and platings			
7M			

1. Contacts arrangement

Refer to page 18 for contact arrangements - HE308. First number represents the shell size and second number is the contact arrangement.

3. Keying

N	A	B	C	D
---	---	---	---	---

(for normal)

Refer to page 28 for keying information.

2. Contact gender

PS Pin and socket (500 cycles)

4. Material and platings

	Shell material	Shell finish
7M	Aluminum	Olive drab cadmium
6M		Nickel ✓

Amphenol Designations - Thru-bulkhead receptacles

1.	2.	3.	4.
Series	Contacts arrangement	Contact gender	Keying
LJTB	17-06	PS	N
Material and platings			
014			

1. Contacts arrangement

Refer to page 18 for contact arrangements - LJT / MIL-DTL-38999 Series I. First number represents the shell size and second number is the contact arrangement.

4. Material and platings

	Shell material	Shell finish
014	Aluminum	Olive drab cadmium
023		Nickel ✓
033K		Black zinc nickel ✓

2. Contact gender

PS Pin and socket (500 cycles)

3. Keying

N	A	B	C	D
---	---	---	---	---

(for normal)

Refer to page 28 for keying information.

All dimensions are given for information only and are in mm, except as otherwise specified | *in mm: 1mm=0.03937 inch

MIL-DTL-SERIES I, LJT EXTENDED RANGE - THRU-BULKHEAD

Overall dimensions

Overall dimensions

AMPHENOL HE308
LJTB**PS** HE308 0BT**PS**M

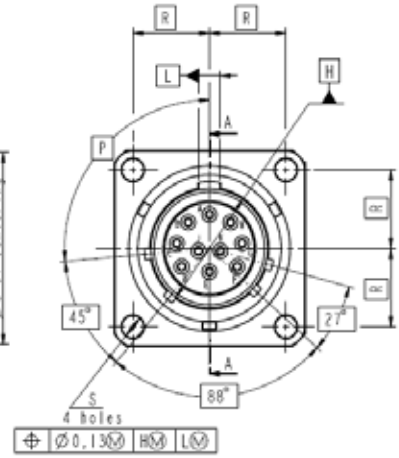
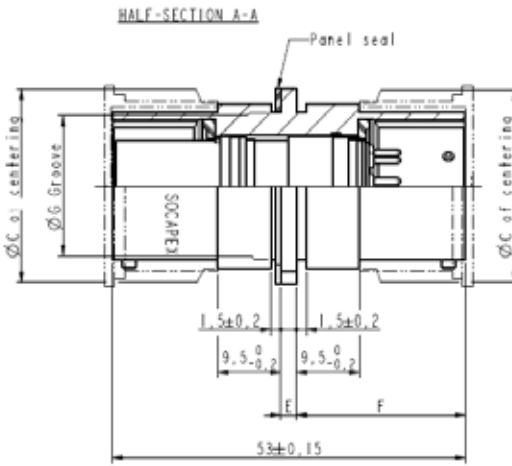
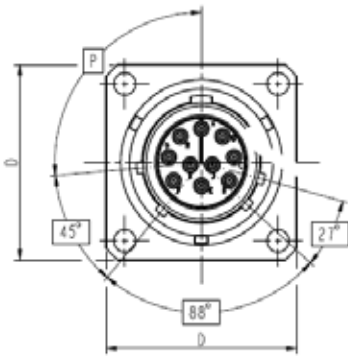

Panel thickness : 2 - 9,5 mm

Shell size	ØC ⁺⁰ / _{-0.2}	ØD ^{±0.51}	ØE ^{±0.15}	ØF ^{±0.1}	ØG ⁺⁰ / _{-0.5}	R	ØS ^{+0.25} / _{-0.13}
11	20.55	26.19			17.81	10.31	
13	24.35	28.58			21.62	11.51	
15	27.55	30.96	2.35	25.3	25	12.31	3.25
17	30.70	34.11			27.97	13.49	
19	33.40	36.81			30.69	14.68	
21	36.60	40.01	3.1	25	33.86	15.88	3.73
23	39.75	43.16			37.04	17.46	
25	42.95	46.36			40.21	19.05	

Keyway - P°				
N	A	B	C	D
95°	81°	67°	123°	109°
95°	75°	63°	127°	115°
95°	74°	61°	129°	116°
95°	77°	65°	125°	113°
95°	77°	65°	125°	113°
95°	77°	65°	125°	113°
95°	80°	69°	121°	110°
95°	80°	69°	121°	110°

All dimensions are given for information only and are in mm, except as otherwise specified | *in mm: 1mm=0.03937 inch

MIL-DTL-SERIES I, LJT EXTENDED RANGE - RNJ - RACK & PANEL

Rack and Panel range for blind mate connections

 Video available to help you on our website www.amphenol-socapex.com/en/videos/:
RNJ - Rack and Panel Blind Mate Connectors



Description - RNJ Range

Rack and panel range derived from MIL-DTL-38999 Series I standard and HE308 qualified Realignment and floatability capabilities.

Connection between a rack (moving unit) and a panel (fixed structure) without manually coupling/uncoupling.

Main features

EASY TO USE: Push to mate easy and fast connection.

AXIAL, ANGULAR AND LONGITUDINAL FLOTABILITY

EMI/EMP SHIELDING: Grounding fingers ensuring shielding before contact mating.

CONTACTS PROTECTION: Scoop-proof design.

HIGH DURABILITY: 500 mated cycles.

MATERIAL

- Shell: Aluminum or Stainless steel
- Plating: Olive drab cadmium, Nickel, Black zinc nickel or Passivated (Stainless steel)

38999 SERIES I & III STANDARD ARRANGEMENTS AND CONTACTS

- Available with high-density inserts ^{HD}.
- Shells from size 11 to 25.
- Power version available (23P1 & 25P1)
- Optical termini upon request, please consult us.

OPTIONS

- Jam nut or Square flange: **RNJ2***RNJ4***** or **RNJ6***RNJ8*****.
- Plug: rear accessory option **RNJ26***** & **RNJ66*****, compatible with M85049 accessories for 38999 Series I connectors.
- Receptacle: stand-off option **RNJ27***F459** & **RNJ67***F459**.

STANDARD: HE308, for related arrangements (DAT C5935x0005 HE308 21, 25, 26 & 27T).

Plug concept

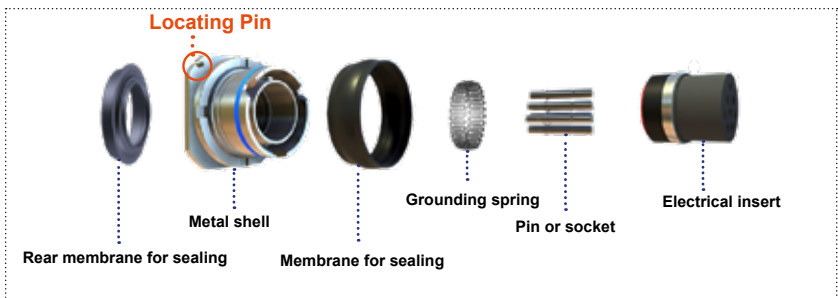

Distance between panels

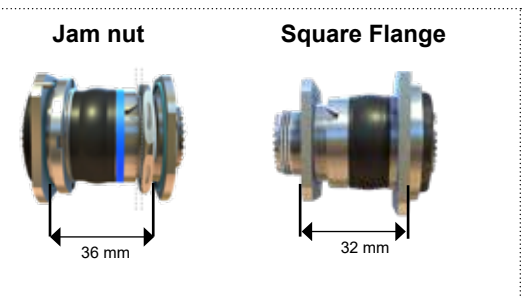

Options

	JAM NUT		SQUARE FLANGE	
Plug RNJ*6**	RNJ26** HE308 26** with rear accessory option	RNJ46** without rear accessory option	RNJ66** with rear accessory option	RNJ86** without rear accessory option
Receptacle RNJ*7**	RNJ27** HE308 27**	RNJ27***F459 Stand-off	RNJ67**	RNJ67***F459 Stand-off

^{HD} High density 38999

MIL-DTL-SERIES I, LJT EXTENDED RANGE - RNJ - RACK & PANEL

Floating features

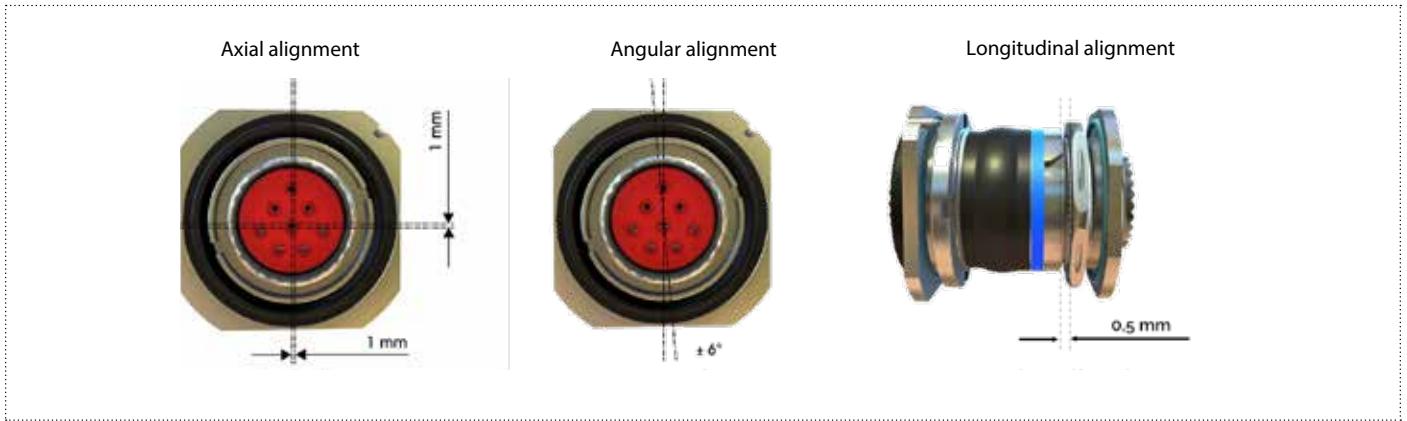

Environmental characteristics

Qualified according to HE308 standard	
Air leakage (cm³/h)	Receptacle RNJ27: limited to 16 cm³/h @ 2 bar Plug RNJ26/RNJ46: limited to 16 cm³/h @ 2 bar, front face - limited to 4cm³/h @0.5 bar, rear face Extra sealing option upon request
Corrosion resistance. Salt spray (hours)	Aluminum : - Olive drab cadmium 500h - Electroless nickel 48h - Black zinc nickel, 96h - Tin Zinc, 500H Stainless steel - Passivated or Nickel plated, 500h
Fluid resistance	MIL-L-7808 (lubricating oil) MIL-L-23699 (lubricating oil) MIL-H-5606 (hydraulic fluid) Hydraulic fluid (Chevron M2V) MIL A-8243 (defrosting fluid) MIL- C- 87936 type I MIL-T-5624 (JP5) MIL-C-47220 or Coolanol 25 or equivalent MIL-G-3056 type I (gasoline) Isopropyl alcohol per TT-I-735 grade A or B mixed with mineral spirit TT-T-291 type I or P-D-680 type I
Durability	500 cycles
Temperature	-65°C to +200°C (Aluminum Nickel plated, Stainless steel Passivated or Nickel plated) -65°C to +175°C (Aluminum, Olive drab cadmium and Black zinc nickel plated)

Shown in this section are the specific technical characteristics. For non specified characteristics, consult LJT / MIL-DTL-38999 I section

Mating and unmating forces

Following HE308 standard

Size	Maximum mating force (daN)	Maximum unmating force (daN)
11	20	12
13	30	13
15	35	15
17	50	16
19	55	18
21	65	22
23	80	27
25	102	34

All dimensions are given for information only and are in mm, except as otherwise specified | *in mm: 1mm=0.03937 inch

MIL-DTL-SERIES I, LJT - HOW TO ORDER - RNJ

Military Designations - HE308 - UTE 93422 Connectors

	1.	2.	3.	4.	5.	6.	7.
Series	Shell type	Crimp contacts	Contact arrangement	Contact gender	Keying	Material and platings	With or without contacts
HE308	26	T	15-05	S	N	6M	L

1. Shell type

Code	Shell type	Description
27	Receptacle	Jam-nut receptacle
26	Plug	Jam-nut plug
25		Jam-nut plug without rear accessory possibility

2. Crimp contact

Code	Description
T	Crimp contacts

3. Contact arrangements

Refer to page 18 for contact arrangements - HE308.
First number represents the shell size and second number is the contact arrangement.

4. Contact gender

Code	Description
P	Pin (500 cycles)
S	Socket (500 cycles)

5. Keying

Code	Description
N (for normal)	N keying only

6. Material and platings

Code	Shell material	Shell finish
7M	Aluminum	Olive drab cadmium
6M		Nickel ✓

7. With or without contacts

Code	Description
Blank	Connector delivered with contacts
L	Connector delivered without contact

Amphenol Designations - RNJ Crimp connectors

	1.	2.	3.	4.	5.	6.	7.	8.
Series	Shell type	Crimp contacts	Contact arrangement	Contact gender	Keying	Material and platings	With or without contacts	Deviation
RNJ	27	T	15-35	P	N	023	-	-

1. Shell type

Code	Shell type	Description
27	Receptacle	Jam-nut receptacle
67		Square flange receptacle
26	Plug	Jam-nut plug
66		Square flange plug

2. Crimp contact

Code	Description
T	Crimp contacts

3. Contact arrangements

Refer to page 18 for contact arrangements.
First number represents the shell size and second number is the contact arrangement.

4. Contact gender

Code	Description
P	Pin (500 cycles)
S	Socket (500 cycles)

5. Keying

Code	Description
N (for normal)	For other coding possibilities, please consult us

6. Material and platings

Code	Shell material	Shell finish
014	Aluminum	Olive drab cadmium
023		Nickel ✓
033K		Black Zinc Nickel ✓
078		Black Zinc Nickel CrVI free ✓
076		Tin Zinc ✓

For other materials/platings, please consult us.

7. With or without contacts

Code	Description
Blank	Connector delivered with contacts
LC	Connector delivered without contact

8. Deviation

Code	Description	Shell type
F312	Reduced flange receptacle	26/27

For other deviations, please consult us.

✓ : RoHS compliant

All dimensions are given for information only and are in mm, except as otherwise specified | *in mm: 1mm=0.03937 inch

MIL-DTL-SERIES I, LJT - HOW TO ORDER - RNJ

Amphenol Designations - RNJ PCB connectors

	1.	2.	3.	4.	5.	6.	7.
Series	Shell type	PC Tail contact	Contact arrangement	Contact gender	Keying	Material and platings	Deviation
RNJ	27	CI	15-35	P	N	023	F459

1. Shell type

27	Receptacles	Jam-nut receptacle
67		Square flange receptacle
46	Plugs	Jam-nut plug without rear accessory possibility
86		Square flange plug without rear accessory possibility

2. PC tail contact

CI	Standard length
LI	Long length

3. Contact arrangement

Refer to page 18 for contact arrangements
First number represents the shell size and second number is the contact arrangement.

4. Contact gender

P	Pin (500 cycles)
S	Socket (500 cycles)

Connectors with PC Tail contacts are always delivered with contacts.

5. Keying

N (for normal)	For other coding possibilities, please consult us
-------------------	---

6. Material and platings

	Shell material	Shell finish
014	Aluminum	Olive drab cadmium
023		Nickel ✓
033K		Black Zinc Nickel ✓
078		Black Zinc Nickel CrVI free ✓
076		Tin Zinc ✓

For other materials/platings, please consult us.

7. Deviation

Shell style	PC Tail finish / Tinning				Shell type compatibility
	Tin lead	Silver tin ✓	Silver tin copper ✓	Gold ✓	
Standard	F404	F404LF	F404LFC	Blank	All
Stand-off *	F459	F459LF	F459LFC	F459H	27/67
Reduced flange	F312	F312LF	F312LFC	F312G	26/27/46
Stand-off reduced flange	F059	F059LF	F059LFC	F059G	26/27/46

* For receptacles only (consult us for plugs)
For other deviations, please consult us.

Amphenol Designations - RNJ Receptacles with enhanced sealing

	1.	2.	3.	4.	5.	6.	7.	8.
Series	Shell type	Enhanced sealing	Contact type	Contact arrangement	Contact gender	Keying	Material and platings	Deviation
RNJ	27	ET	C	15-35	P	N	023	-

1. Shell type

27	Receptacles	Jam-nut receptacle
67		Square flange receptacle

2. Enhanced sealing

ET	Mandatory
----	-----------

3. Contact type - Non-removable contacts only

CI	PC Tail contacts - Standard length
LI	PC Tail contacts - Long length
C	Solder cup contacts

4. Contact arrangements

Refer to page 18 for contact arrangements
First number represents the shell size and second number is the contact arrangement.

5. Contact gender

P	Pin (500 cycles)
S	Socket (500 cycles)

Enhanced sealing receptacles are always delivered with contacts.

6. Keying

N (for normal)	For other coding possibilities, please consult us
-------------------	---

7. Material and platings

	Shell material	Shell finish
014	Aluminum	Olive drab cadmium
023		Nickel ✓
033K		Black Zinc Nickel ✓
078		Black Zinc Nickel CrVI free ✓
076		Tin Zinc ✓

For other materials/platings, please consult us.

8. Deviation

Shell style	PC Tail finish / Tinning				Shell type compatibility
	Tin lead	Silver tin ✓	Silver tin copper ✓	Gold ✓	
Standard	F404	F404LF	F404LFC	Blank	All
Stand-off *	F459	F459LF	F459LFC	F459H	27/67
Reduced flange	F312	F312LF	F312LFC	F312G	26/27/46
Stand-off reduced flange	F059	F059LF	F059LFC	F059G	26/27/46

* For receptacles only (consult us for plugs)
For other deviations, please consult us.

✓: RoHS compliant

All dimensions are given for information only and are in mm, except as otherwise specified | *in mm: 1mm=0.03937 inch

MIL-DTL-SERIES I, LJT EXTENDED RANGE - RNJ - RACK & PANEL

Panel integration

Mandatory distance to guarantee the product performances.
 Guiding system: the system must ensure the right positioning of the rack independently of the connectors.
 No mechanical stress must be applied to the rear of the plug (wires).

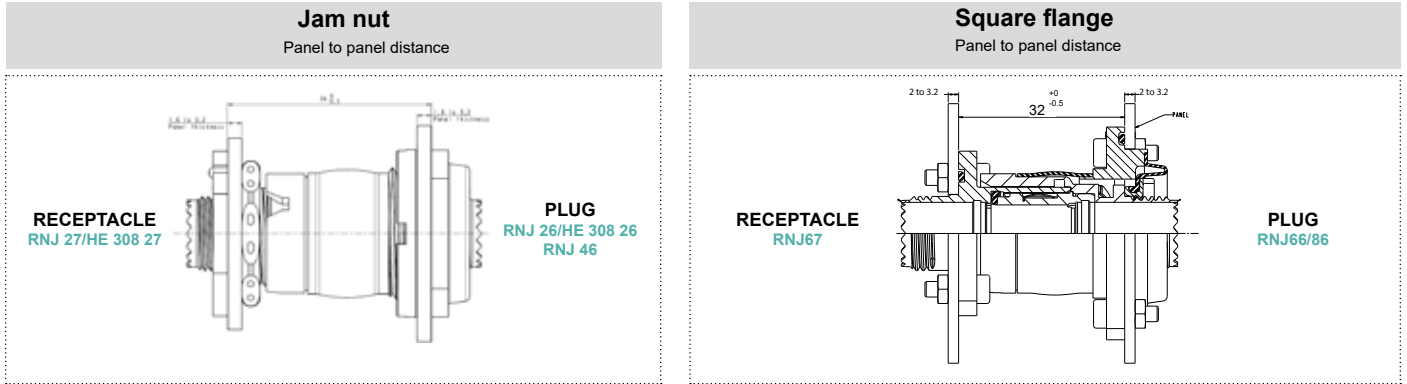

Panel mounting direction

	Plug		Receptacle			
	Jam nut RNJ26/46	Square flange RNJ66/86	Jam nut RNJ27	Jam nut Stand-off RNJ27*1***F459	Square flange RNJ67	Square flange Stand-off RNJ67*1***F459
Back panel mounting	✓	NA	✓	✓	NA	✓
Front panel mounting	NA	✓	NA	NA	✓	NA

Plug rear accessory assembly & Clamping bush

RNJ26*** & RNJ66*** plugs are compatible with M85049 accessories for 38999 Series I connectors.
 Locking glue has to be put on the rear thread of the connector before rear accessory assembly.
 The use of a holding support to mount the accessory on the plug is mandatory to prevent strain on the internal set of the plug.

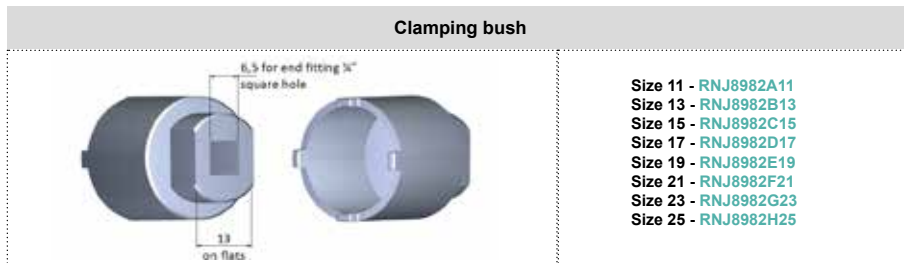

Size	A11	B13	C15	D17	E19	F21	G23	H25
Recommended coupling torque (Nm)	8 ± 0.4	11 ± 0.5	11 ± 0.5	14 ± 0.7	14 ± 0.7	17 ± 0.8	17 ± 0.8	20 ± 1

Weight

In grams, average (includes contacts) ± 15%

Size	Jam nut plug RNJ26** / HE308 26**		Jam nut receptacle RNJ27** / HE30827**	
	Pin	Socket	Pin	Socket
11	24	28	16	19.5
13	28	34	22.5	28
15	32	41	28	37
17	38	51	33	46.5
19	48	65	41.5	58.5
21	67	87	50.5	71
23	83	111	55.5	82.5
25	104	125	63	98

All dimensions are given for information only and are in mm, except as otherwise specified | *in mm: 1mm=0.03937 inch

MIL-DTL-SERIES I, LJT EXTENDED RANGE - RNJ - RACK & PANEL

Overall dimensions Square Flange receptacle

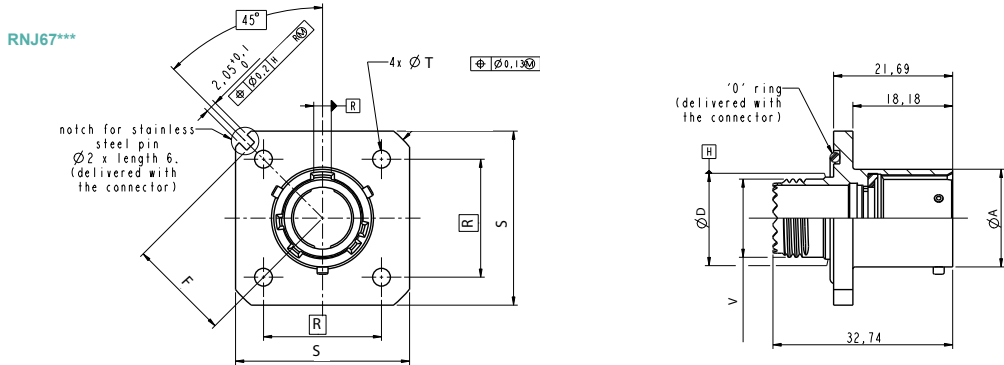

Size	S	R	F	$\text{ØD}^0_{-0.05}$	ØA	V thread UNEF class 2A	$\text{ØT}^{+0.13}_0$
11	31.7	21.5	18.5	15	17.81	.5625-24	3.22
13	34.9	24.6	20.5	18	21.62	.6875-24	3.22
15	38	26.6	22	21	24.80	.8125-20	3.22
17	41.2	29	24	24	27.97	.9375-20	3.22
19	45	32	26	28	30.69	1.0625-18	3.22
21	48	34	27.5	31	33.86	1.1875-18	3.22
23	51	36	29	34	37.04	1.3125-18	3.7
25	54	38	30.5	37	40.21	1.4375-18	3.7

Jam nut receptacle

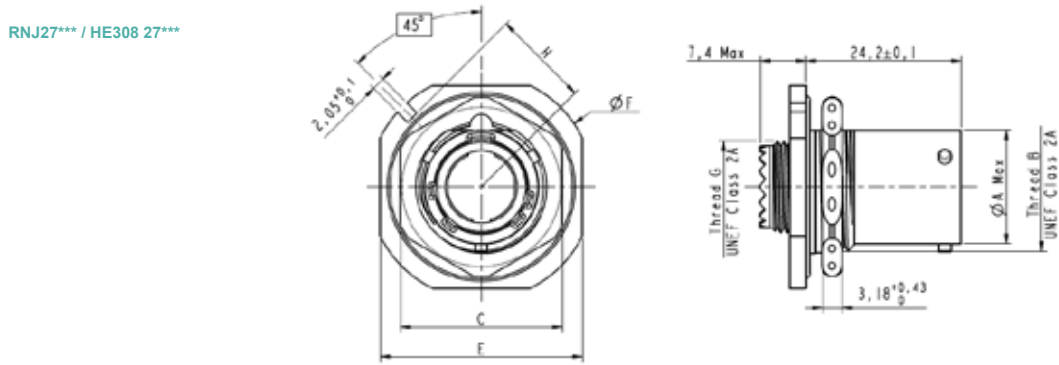

Size	ØA_{MAX}	B thread UNEF Class 2A	C_{MAX}	$E^0_{+0.48}$	$\text{ØF}^{+0}_{-0.3}$	V Thread UNEF Class 2A	$H^0_{-0.2}$
11	17.81	.8125-20	25.80	31.49	35.20	.5625-24	15.33
13	21.62	1.000-20	30.00	34.69	38.37	.6875-24	16.92
15	24.80	1.125-18	33.00	37.79	41.55	.8125-20	18.51
17	27.97	1.250-18	37.00	40.99	44.72	.9375-20	20.10
19	30.69	1.375-18	40.00	45.79	49.50	1.0625-18	22.67
21	33.86	1.500-18	43.00	48.99	52.64	1.1875-18	24.26
23	37.04	1.625-18	46.00	52.09	55.85	1.3125-18	25.84
25	40.22	1.750-18	51.20	55.29	58.99	1.4375-18	27.43

All dimensions are given for information only and are in mm, except as otherwise specified | *in mm: 1mm=0.03937 inch

MIL-DTL-SERIES I, LJT EXTENDED RANGE - RNJ - RACK & PANEL

Jam-nut Stand-off receptacle

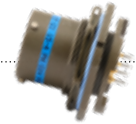

RNJ27CI**F459**
RNJ27LI**F459**

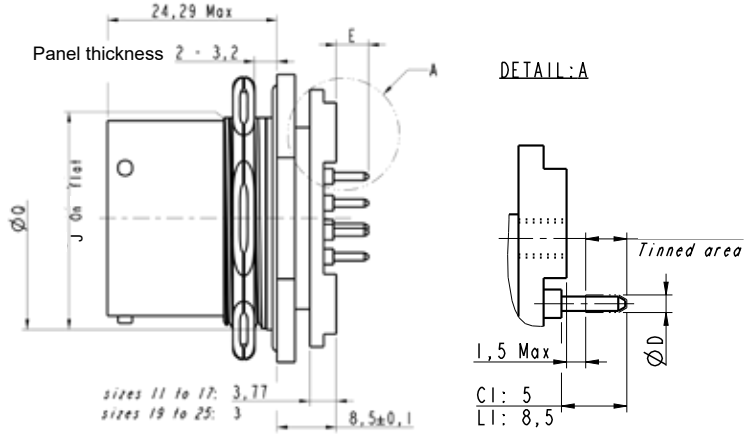

	CI	E	LI
Socket contacts	3.99 - 5.07	7.49 - 8.57	
Pin contacts	4.19 - 5.27	7.69 - 8.77	

Contact size	ØD _{MAX}	
	CI	LI
22D	0.6	0.8
20	0.8	0.8
16	1.25	1.25
12	1.8	1.8

For panel drilling, please refer to page 32.

Size	ØQ ^{+0 -0.05}	J ^{+0 -0.05}	ØQ ^{+0 -0.05}
11	20.83	19.23	20.83
13	25.53	23.96	25.53
15	28.75	27.23	28.75
17	31.93	30.38	31.93
19	35.10	33.56	35.10
21	38.23	36.76	38.23
23	41.45	39.84	41.45
25	44.63	43.11	44.63

PCB mounting

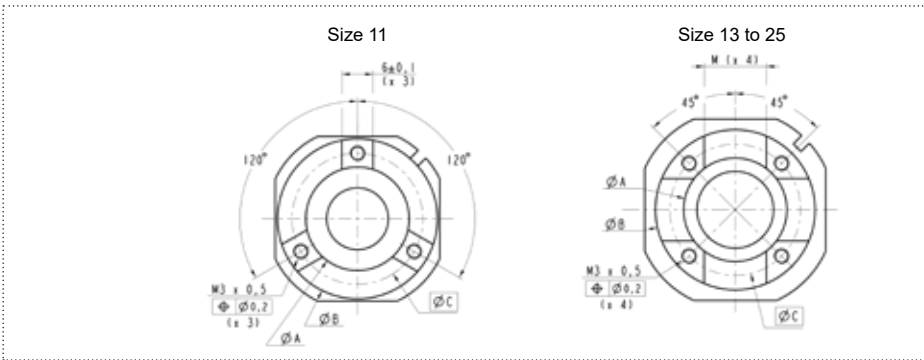

Size	ØA ± 0.15	ØB ± 0.15	ØC	M ^{+0.2 -0}
11	19.9	30.8	25.2	-
13	19.9	30.8	25.25	12
15	23	33.9	28.42	14
17	26	36.8	31.42	16
19	29.5	40.4	35.03	18
21	32.2	43.2	37.82	20
23	35.5	46.5	41.12	23
25	38.6	49.6	44.3	25

All dimensions are given for information only and are in mm, except as otherwise specified | *in mm: 1mm=0.03937 inch

MIL-DTL-SERIES I, LJT EXTENDED RANGE - RNJ - RACK & PANEL

Square Flange plug



RNJ66*** plug compatible with M85049 accessories for 38999 Series I connectors
RNJ86** without rear accessory possibility

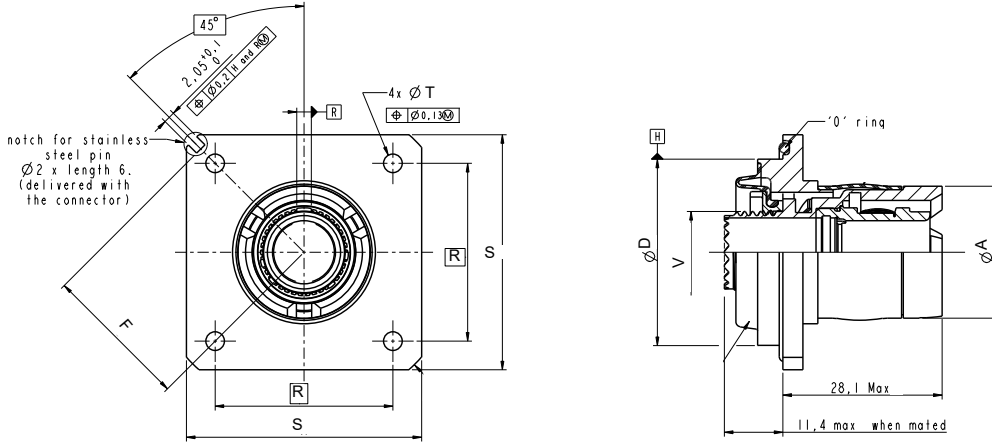

Size	S	R	F	ϕD ⁰ _{-0.05}	ϕA	V thread UNEF class 2A	ϕT ^{+0.13} ₀
11	41	31	25.5	32.5	23.03	.5625-24	3.22
13	44	33	27	36	26.83	.6875-24	3.22
15	47	35	28.5	38.5	30.03	.8125-20	3.22
17	50	38	30.5	42	33.25	.9375-20	3.22
19	54	40	32	46.5	36.23	1.0625-18	3.22
21	57	43	34	49.5	39.43	1.1875-18	3.22
23	60	45	35.5	53	42.63	1.3125-18	3.7
25	63	46	36.5	54	45.71	1.4375-18	3.7

Jam nut plug



RNJ26* / HE308 26***** compatible with M85049 accessories for 38999 Series I connectors.
RNJ46*** without rear accessory possibility.

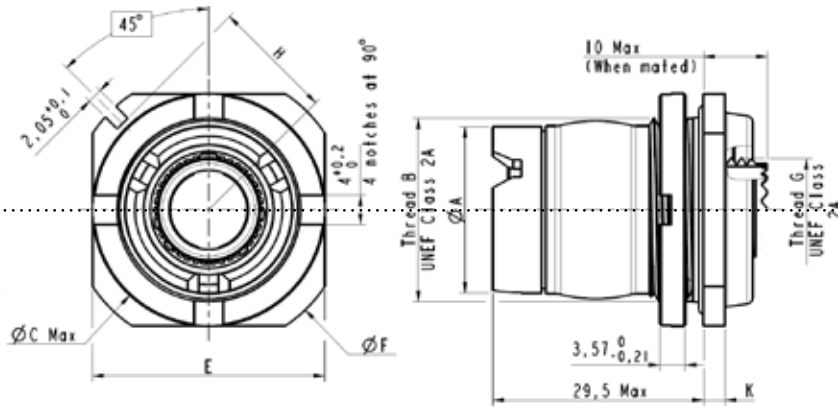

RNJ26/HE308 26**** with rear accessory

RNJ46** without rear accessory possibility

Size	ϕA ^{+0.03} _{-0.1}	Thread B UNEF Class 2A	C _{MAX}	E ⁰ _{-0.25}	ϕF ^{± 0.41}	Thread G UNEF Class 2A	H ⁰ _{-0.25}	K ^{+0.28} _{-0.25}
11	23.0	1.000-20	32.23	32.16	38.10	.5625-24	16.92	2.77
13	26.8	1.125-18	35.25	35.34	41.28	.6875-24	18.51	2.77
15	30.0	1.250-18	38.40	38.51	44.45	.8125-20	20.10	2.77
17	33.22	1.375-18	41.60	41.69	49.23	.9375-20	22.67	2.77
19	36.2	1.500-18	46.30	46.43	52.37	1.0625-18	24.26	3.56
21	39.4	1.625-18	49.60	49.64	55.58	1.1875-18	25.84	3.56
23	42.6	1.750-18	52.70	52.78	58.72	1.3125-18	27.43	3.56
25	45.68	1.875-16	53.93	54.03	59.10	1.4375-18	27.58	3.56

All dimensions are given for information only and are in mm, except as otherwise specified | ¹in mm: 1mm=0.03937 inch

MIL-DTL-SERIES I, LJT EXTENDED RANGE - RNJ - RACK & PANEL

Panel holes dimensions

A stainless steel pin is provided to ensure a perfect positioning of the connector on the panel. Only RNJ specific dimensions are mentioned. Please refer to MIL-DTL-38999 Series I standard range for missing dimensions.

Square flange receptacle - RNJ67

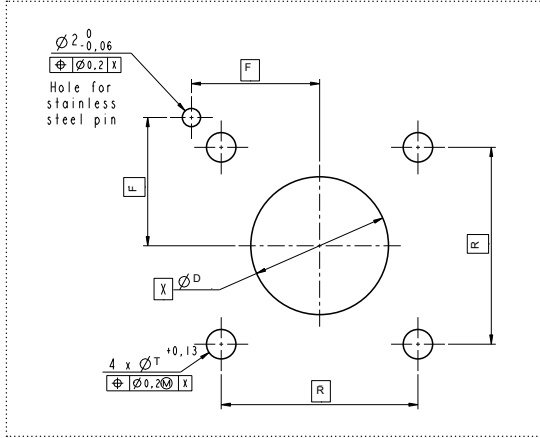

Size	R	F	ØT ^{+0.13} / ₀	ØD ^{+0.1} / ₀
11	21.5	14	3.22	15.05
13	24.6	15.5	3.22	18.05
15	26.6	16.5	3.22	21.05
17	29	18	3.22	24.05
19	32	19.5	3.22	28.05
21	34	20.5	3.22	31.05
23	36	21.5	3.7	34.05
25	38	22.5	3.7	37.05

Jam nut receptacle - RNJ27

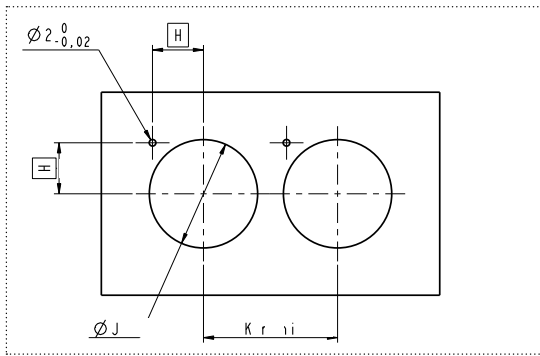

Size	H	ØJ ^{+0.1} / ₀	K _{MIN}
11	11.69	20.88	32.6
13	12.81	25.58	36.0
15	13.94	28.80	39.6
17	15.05	31.98	43.3
19	16.88	35.15	47.0
21	18.00	38.28	50.6
23	19.12	41.50	54.2
25	20.24	44.68	59.7

Square flange plug - RNJ66

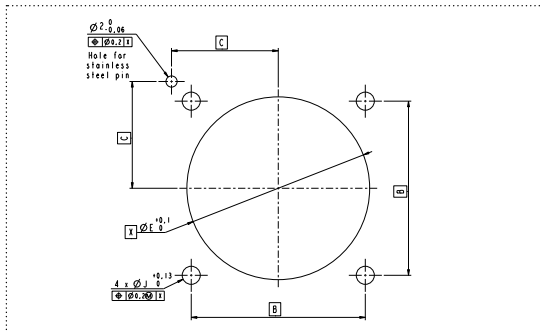

Size	B	C	ØJ ^{+0.13} / ₀	ØE ^{+0.1} / ₀
11	31	19	3.22	32.55
13	33	20	3.22	36.05
15	36	21	3.22	38.55
17	38	22.5	3.22	42.05
19	40	23.5	3.22	46.55
21	43	25	3.22	49.55
23	45	26	3.7	53.05
25	46	27	3.7	54.05

Jam nut plug - RNJ26

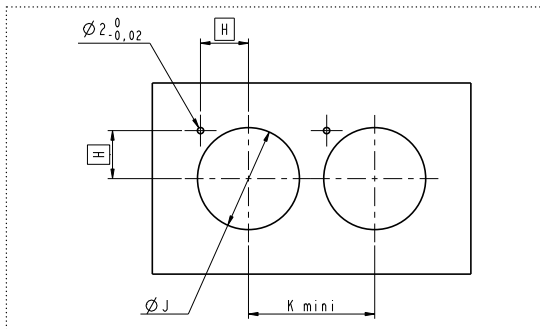

Size	V _{MIN}	W	ØD ^{+0.1} / ₋₀
11	32.6	12.81	25.58
13	36.0	13.94	28.80
15	39.6	15.06	31.98
17	43.3	16.88	35.15
19	47.0	18.00	38.28
21	50.6	19.12	41.50
23	54.2	20.24	44.68
25	59.7	20.30	48.08

All dimensions are given for information only and are in mm, except as otherwise specified | *in mm: 1mm=0.03937 inch

MIL-DTL-SERIES I, LJT EXTENDED RANGE - RNJ - RACK & PANEL

When small dimensions & lower weight are critical



Description

Rack and Panel connectors offering realignment and floatability for blind mate applications in harsh environments, with a smaller flange and weight.

Main features

- Derived from RNJ, same performances, floatability and realignment
- Higher density on panel and lower weight than Standard RNJ
- Available for Jam nut plug and receptacle only
- Compatible with RNJ Standard range (including Square Flange)
- Available with all 38999 series I & III inserts, including HD ones
- Crimp version, with PC tail contacts and in stand off version.

MATERIAL

- Shell: Aluminum or Stainless steel
- Plating: Olive drab cadmium, Tin Zinc, Nickel, Black zinc nickel or Passivated (Stainless steel)

with standard castle nut		with safety castle nut		See part how to order page 197	
F312 or F059	F311 or F058	AMPHENOL	DEVIATIONS		
		Crimp and standard PC tail with standard castle nut	RNJ**F312		
		Crimp and standard PC tail with safety castle nut	RNJ**F311		
		Stand-off PC tail with standard castle nut	RNJ**F059		
		Stand-off PC tail with safety castle nut	RNJ**F058		

Footprint saving

Average 30% Footprint reduction

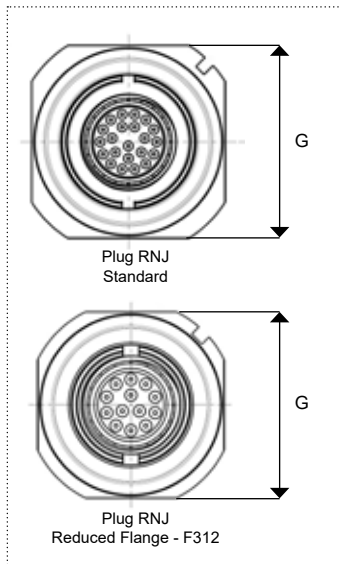

Shell Size	Standard RNJ G max (mm)	RNJ F312/F059 G max (mm)	Footprint Reduction
11	32,16	27,03	-39,07%
13	35,34	31,03	-33,24%
15	38,51	34,53	-29,88%
17	41,69	38,53	-29,89%
19	46,43	41,53	-28,74%
21	49,64	44,53	-27,86%
23	52,78	47,53	-24,36%
25	54,03	50,53	-19,06%

Footprint dimensions are the same in Standard & Stand-off versions

Tooling

Specific tool for the castle nut clamping:

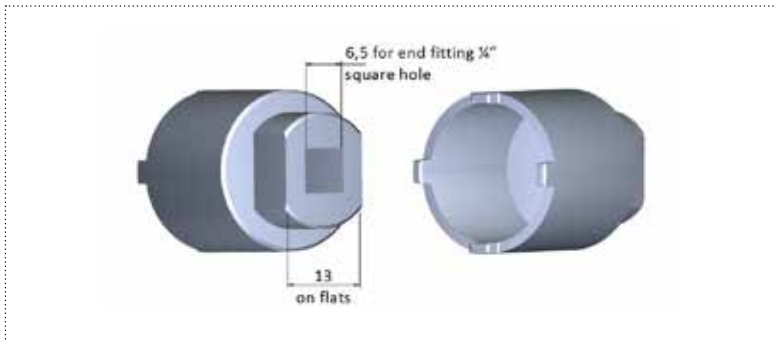

Shell Size	Tools Part Number
11	809642
13	809643
15	809644
17	809645
19	809646
21	809647
23	809648
25	809649

All dimensions are given for information only and are in mm, except as otherwise specified | *in mm: 1mm=0.03937 inch

MIL-DTL-SERIES I, LJT EXTENDED RANGE - RNJ - RACK & PANEL

Overall dimensions Jam nut receptacle reduced flange



RNJ27***F312
RNJ27***F311

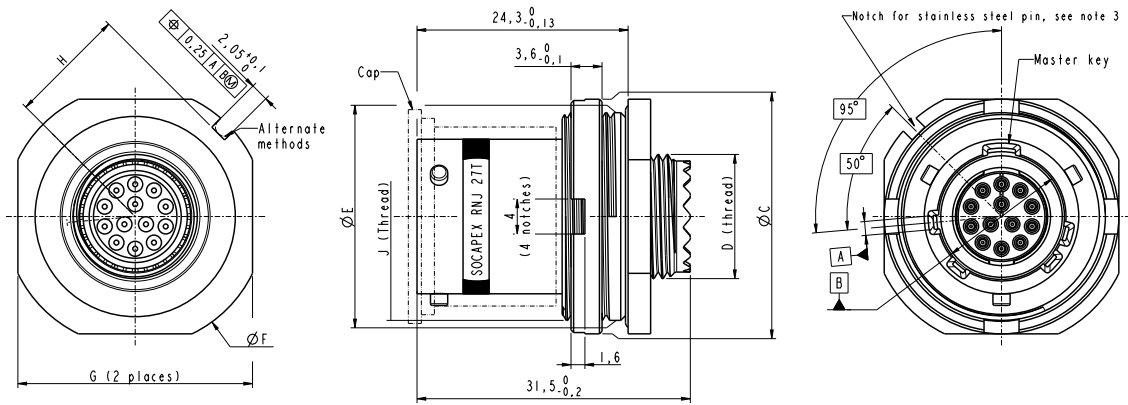

Size	ØC +0 -0.1	D Thread Class 2A	ØE +0 -0.1	ØF +0 -0.2	G +0 -0.1	H +0 -0.1	J Thread - 6 g
11	27.03	0.5625-24	23.93	30.03	27.03	13.5	M24 x 1
13	31.03	0.6875-24	27.93	34.03	31.03	15.5	M28 x 1
15	34.43	0.8125-20	30.93	37.53	34.53	17.1	M31 x 1
17	38.43	0.9375-20	34.93	41.53	38.53	19.1	M35 x 1
19	41.43	1.0625-18	37.93	44.53	41.53	20.6	M38 x 1
21	44.43	1.1875-18	40.93	47.53	44.53	22.1	M41 x 1
23	47.43	1.3125-18	43.93	50.53	47.53	23.6	M44 x 1
25	50.43	1.4375-18	46.93	53.53	50.53	25.1	M47 x 1

Jam nut plug reduced flange



RNJ26***F312 / RNJ46***F312
RNJ26***F311 / RNJ46***F311

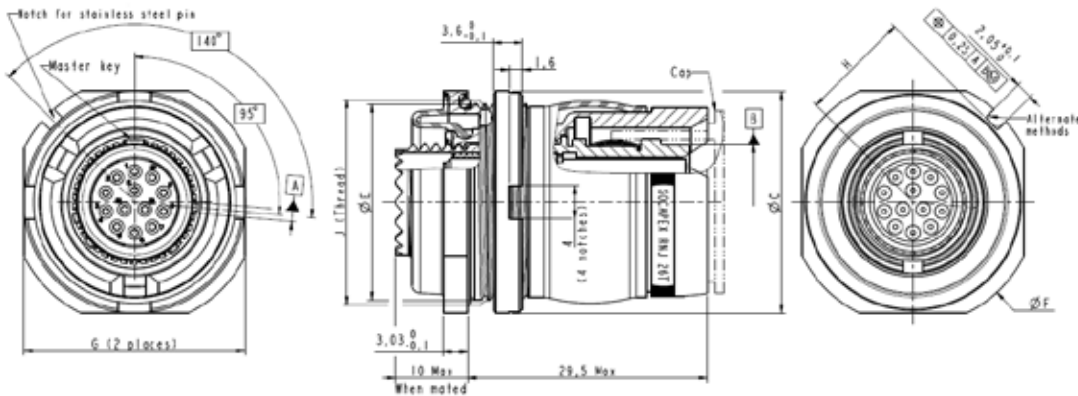

Size	ØC +0 -0.1	ØE +0 -0.1	ØF +0 -0.2	G +0 -0.1	H +0 -0.1	J Thread - 6 g
11	27.03	23.93	30.03	27.03	13.5	M24 x 1
13	31.03	27.93	34.03	31.03	15.5	M28 x 1
15	34.43	30.93	37.53	34.53	17.1	M31 x 1
17	38.43	34.93	41.53	38.53	19.1	M35 x 1
19	41.43	37.93	44.53	41.53	20.6	M38 x 1
21	44.43	40.93	47.53	44.53	22.1	M41 x 1
23	47.43	43.93	50.53	47.53	23.6	M44 x 1
25	50.43	46.93	53.53	50.53	25.1	M47 x 1

All dimensions are given for information only and are in mm, except as otherwise specified | *in mm: 1mm=0.03937 inch

MIL-DTL-SERIES I, LJT EXTENDED RANGE - RNJ - RACK & PANEL

Panel integration

Mandatory distance to guarantee the product performances.

Guiding system: the system must ensure the right positioning of the rack independently of the connectors.

No mechanical stress must be applied to the rear of the plug (wires).

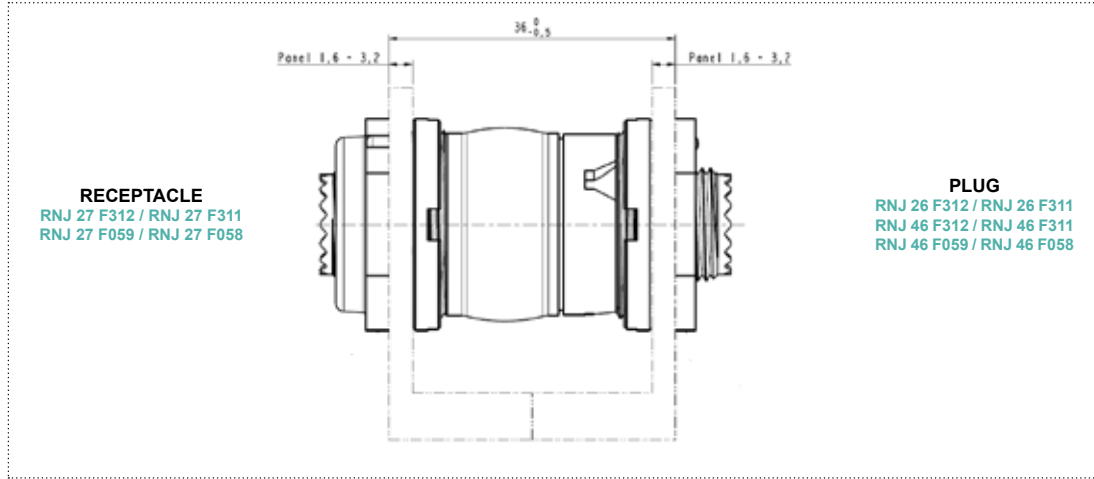

Panel dimension - Plug & Receptacle

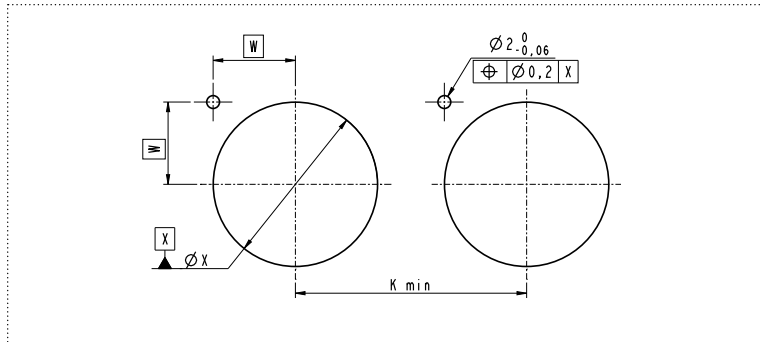

Shell Size	K _{MIN}	W	ØX ^{+0,1}
11	27,6	10,3	24
13	31,6	11,7	28
15	35,1	12,9	31
17	39,1	14,3	35
19	42,1	15,4	38
21	45,1	16,4	41
23	48,1	17,5	44
25	51,1	18,6	47

All dimensions are given for information only and are in mm, except as otherwise specified | *in mm: 1mm=0.03937 inch

MIL-DTL-SERIES I, LJT EXTENDED RANGE - LJTOP - BAYONET FIBER OPTIC



Optical fiber in a LJT shell.

Description

Optical version of the MIL-DTL-38999 Series I connectors, using standard 2.5mm telecom optical termini in a LJT shell.

Main features

- 1 to 8 channels.
- Available in multimode, singlemode PC and singlemode APC.
- 0.5 dB typical insertion loss in multimode and singlemode.
- Size 11, 13 or 17 shell

OPTIONS

- Square Flange or Jam nut receptacle
- Aluminum shell with OD. Cadmium or Nickel plating
- Straight or right angle backshell heatshrinkable, for pigtails or with clamp

Insert arrangements

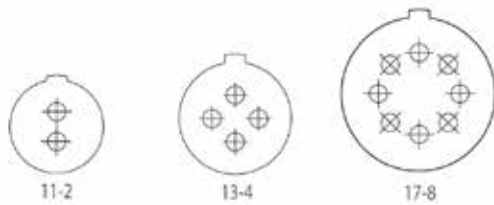

Optical termini

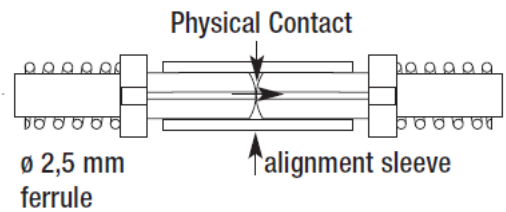

Amphenol Designations - LJTOP & RNJOP

1. Series	2. Shell type	3. Material and platings	4. Backshell type	5. Shell size - Number of channel	6. Type of ceramic ferrule / Ceramic ferrule inner diameter	7. Keying	8. Cable option
TVOP	06	F	H0	11 - 2	P6	N	X015

1. Series

LJTOP	LJT shell with fiber optic
RNJOP	RNJ shell with fiber optic

5. Shell size / Number of channel

11 - 2	Size 11 - 2 channels max
13 - 4	Size 13 - 4 channels max
17 - 8	Size 17 - 8 channels max

2. Shell type

6	Straight plug
7PE	Square flange receptacle
7PEM	Jam nut receptacle

6. Type of ceramic ferrule / Ceramic ferrule inner diameter

Multimode	P7	Physical contact ferrule. 127 µm
Singlemode	P6	Physical contact ferrule. 126 µm
	A	Angle physical contact ferrule. 126 µm

3. Material and platings

	Shell material	Shell finish
W	Aluminum	Olive drab cadmium
F		Nickel ✓
ZN		Black zinc nickel ✓

7. Keying

N (for normal)	A	B	C	D
-------------------	---	---	---	---

8. Cable option

X055	Ø 5.5mm multiway cable (for backshell H0, H9, S3, S4, S5)
X015	Ø 1.5mm for pigtail (for backshell R0 only)

4. Backshell type

H0	Straight heatshrinkable backshell without clamp
H9	Right angle heatshrinkable backshell without clamp
S3	Straight backshell for multiway cable with metal integrated clamp
S4	Straight backshell for multiway cable with plastic integrated clamp
S5	Straight backshell for multiway cable with tightening jaws clamp
R0	Straight backshell for pigtails (for receptacles only – P00 / 07 receptacles)

All dimensions are given for information only and are in mm, except as otherwise specified | *in mm: 1mm=0.03937 inch

MIL-DTL-SERIES I, LJT - HOW TO ORDER - FIBER OPTIC

Backshell possibilities Square Flange receptacle

Straight backshell for multiway cable with plastic or metal integrated clamp
LJTOP 00*S3*** / LJTOP 06*S4***

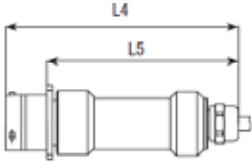

Straight backshell for pigtails
LJTOP 00*R0***

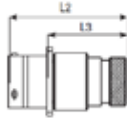

Straight heatshrinkable backshell without clamp
LJTOP 00*H0***

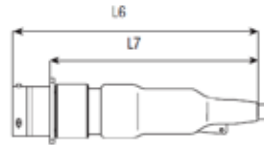

Right angle heatshrinkable backshell without clamp
LJTOP 00*H9***

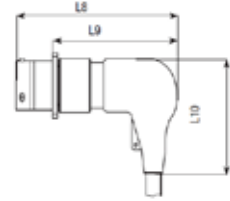

Size	L2	L3	L4	L5	L6	L7	L8	L9	L10
11	48.83	32.78	90.4	74	95.33	79.28	70.33	40.6	40.6
13	48.83	32.78	90.4	74	107.33	91.28	74.63	49.7	49.7
17	48.83	32.78	110	94	120.33	104.28	81.63	59.2	59.2

All dimensions are given for information only and are in mm, except as otherwise specified | *in mm: 1mm=0.03937 inch

MIL-DTL-SERIES I, LJT EXTENDED RANGE - LJTOP - BAYONET FIBER OPTIC

Jam nut receptacle

Straight backshell for multiway cable with plastic or metal integrated clamp
LJTOP 07*S3*** / LJTOP 06*S4***

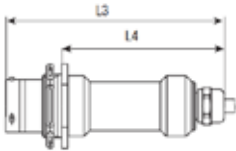

Straight backshell for pigtails
LJTOP 07*R0***

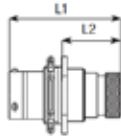

Straight heatshrinkable backshell without clamp
LJTOP 07*H0***

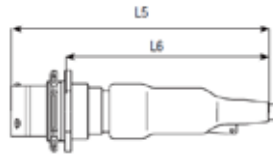

Right angle heatshrinkable backshell without clamp
LJTOP 07*H9***

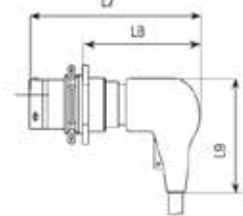

Size	L1	L2	L3	L4	L5	L6	L7	L8	L9
11	49.49	26.25	90.4	67	95.99	72.75	70.99	47.75	40.6
13	49.49	26.25	90.4	67	95.99	72.75	75.29	52.85	49.7
17	49.49	26.25	110	86.8	95.99	72.75	82.29	59.05	50.7

Straight plug

Straight backshell for multiway cable with plastic or metal integrated clamp
LJTOP 06*S3*** / LJTOP 06*S4***

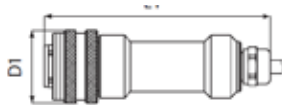

Straight heatshrinkable backshell without clamp
LJTOP 06*H0***

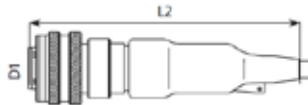

Right angle heatshrinkable backshell without clamp
LJTOP 06*H9***

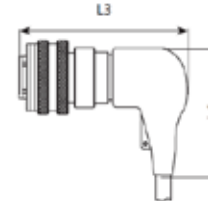

Size	L1	L2	L3	L4	ØD1
11	92	95.33	67.33	40.6	24.5
13	92	107.33	71.33	49.7	28.8
17	114	120.33	78.33	59.2	35.30

For more details, please consult the EWOC catalog (DOC-000503-ANG)

All dimensions are given for information only and are in mm, except as otherwise specified | *in mm: 1mm=0.03937 inch

MIL-DTL-SERIES I, LJT EXTENDED RANGE - RNJOP - RACK&PANEL FIBER OPTIC

Rack & Panel connector with optical terminis.



Description

Optical version of the RNJ connector, using standard 2.5mm telecom optical terminis in a RNJ shell, providing optical connexions for Blind-mate applications, with realignment and floatability

Main features

- Axial, longitudinal and angular realignment
 - 1 to 8 channels.
 - Available in multimode, singlemode PC and singlemode APC.
 - 0.5 dB typical insertion loss in multimode and singlemode.
 - Size 11, 13 or 17 shell
- OPTIONS**
- Aluminum shell with OD. Cadmium or Nickel plating
 - Can be provided with straight backshell for pigtails

Insert arrangements

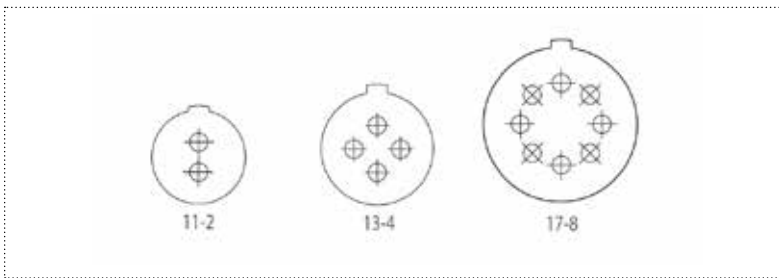

Optical terminis

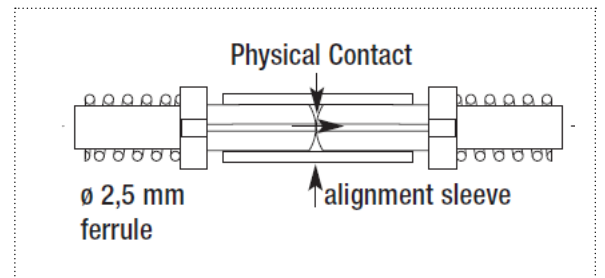

Overall dimensions

Jam nut receptacle

Only RNJOP specific dimensions are mentioned in these figures, for others dimensions consult RNJ section.

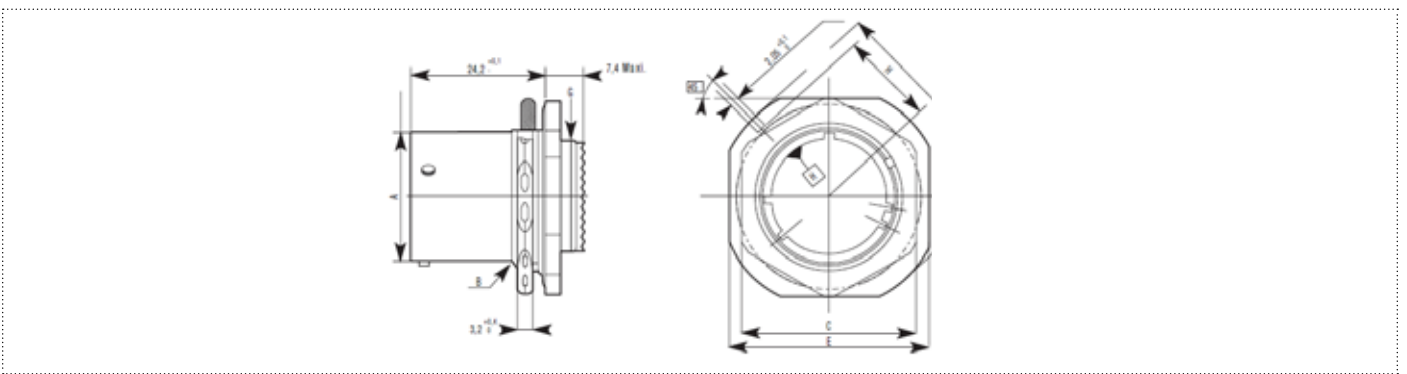

Size	ØA _{MAX}	B Thread Class 2A	C _{MAX}	E ± 0.41	ØF ± 0.41	G Thread Class 2A UNEF	H ± 0.25
11	17.78	0.8125-50 UNEF	25.80	31.75	35.20	0.5625-24	15.33
13	21.59	1.0000-20 UNEF	30	34.92	38.38	0.6875-24	16.92
17	27.94	1.2500-18 UNEF	37	41.27	44.73	0.9375-20	20.10

All dimensions are given for information only and are in mm, except as otherwise specified | *in mm: 1mm=0.03937 inch

NOTES

Area with horizontal dotted lines for notes.

- Series III TVCTV
- Series II JT
- Series I LJT**
- Accessories & tools
- Assembly instructions

All dimensions are given for information only and are in mm, except as otherwise specified | *in mm: 1mm=0.03937 inch

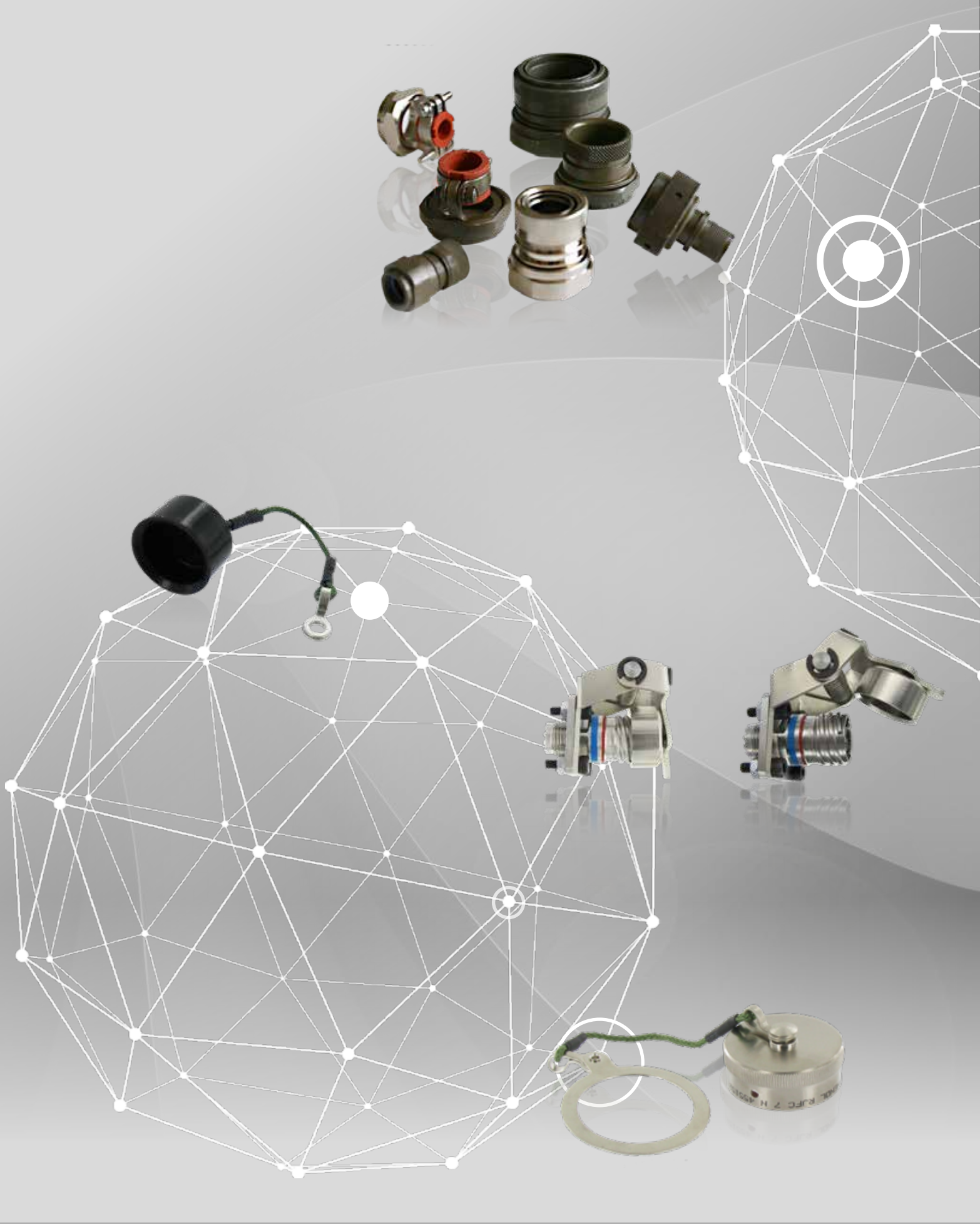

ACCESSORIES & TOOLS



Table of contents

ACCESSORIES & TOOLS	205
BACKSHELLS QUICK SELECTION GUIDE	206
PROTECTIVE CAPS	207
Standard metal cap	207
Rubber cap	211
Self-closing cap	213
Plastic dust cap	215
Stopper for panels	216
OTHERS ACCESSORIES	217
Dummy receptacles	217
Holding support	218
Panel gasket for Square flange receptacles	217
CONTACT ASSEMBLY INSTRUCTIONS	219
Wire stripping, contact crimping, contact insertion & removal	219
Part numbering - Contacts, tooling & accessories	221

Series III TV/CTV

Series II JT

Series I LJT

Accessories & tools

Assembly instructions

THE ACCESSORIES SERVES VARIOUS MARKETS. INCLUDING:



Commercial Avionics & Airframe



Military Avionics & Airframe



Military vehicles



C4ISR



Missiles



Navy



Industrial

ACCESSORIES - METAL BACKSHELL QUICK SELECTION GUIDE

Description

Amphenol offers a full range of backshell for any need and application. These rear accessories enhance the performance capabilities of the connectors in severe environment applications. Several materials & finishes are available as well as numerous versions. For more details, please consult the backshells catalog (DOC-00022-ANG).



	Type	Series availability and designation			Description
		MIL-DTL-38999 Series I, HE308 LJT, RNJ	MIL-DTL-38999 Series II / JT	MIL-DTL-38999 Series III, TV / CTV, SC39, RNJLP	
EMI SHIELDING	STRAIGHT				
		HE308-35	-	TV 35	<ul style="list-style-type: none"> - Full 360° shield termination. - Available with different cabling chambers. - Easy maintenance or repairability. - Sealing ensured by straight or right-angled heat-shrink molded piece.
	RIGHT ANGLE				
		LJT SBC	-	TV SBC	<ul style="list-style-type: none"> - Full 360° shield termination. - Available with different cabling chambers. - Easy maintenance and repairability. - Sealing ensured by straight or right angled heat-shrink molded piece.
	HIGH LEVEL OF EMI/RFI PROTECTIVE				
		LJT NSA HE308-13	-	TV NSA	<ul style="list-style-type: none"> - Electrical continuity between cable and connector by clamping the braid with a screwing system. - Free inner ring to avoid twisting the braid when screwing. - Sealing ensured by straight or right angle heat-shrink molded piece.
SEALING	BAND LOCK ADAPTOR				
		M85049/85 (straight) M85049/87 (90°)	M85049/85 (straight) M85049/87 (90°)	M85049/88 (straight) M85049/90 (90°)	<ul style="list-style-type: none"> - MIL standardized band backshell. - Full 360° termination. - Sealing ensured by straight or right angle heat-shrink molded piece. - Right angle and 45° versions available.
	ADAPTER FOR HEAT-SHRINK MOLDED PIECE				
	LJT NSD HE308-14	-	TV NSD	<ul style="list-style-type: none"> - Ensure the sealing and mechanical retention on the cable. 	
MECHANICAL RETENTION	ADAPTER FOR SEALING GLAND				
		-	-	TV 35M (straight) TV 105 M (90°)	<ul style="list-style-type: none"> - Ensure adaptation on metric sealing gland. - Available in different cabling chamber lengths and rear side.
	M85049/49-2 (straight) M85049/47 (90°)	M85049/49-2 (straight) M85049/47 (90°)	M85049/38 (straight) M85049/39 (90°)	<ul style="list-style-type: none"> - MIL standardized strain relief clamp. - Mechanical retention of the cable. - Easy maintenance or repairability. - Self locking option available. 	

Torques values for rear accessories - According to the SAE-85049 standard:

Shell size	Accessory thread torque value (N.m) ±0.565	
	Heavy duty (All metal connectors)	Metal medium & light duty (Composite connectors only)
08 / 09	8.475	5.650
10 / 11	11.300	5.650
12 / 13	15.820	5.650
14 / 15	16.950	5.650
16 / 17	16.950	5.650
18 / 19	16.950	5.650
20 / 21	19.775	11.300
22 / 23	19.775	11.300
24 / 25	19.775	11.300

Tightening procedure:

The procedure for fitting rear fittings may vary from one equipment manufacturer to another in terms of the torque to be applied.

The use of Loctite is excluded.

For aluminium alloy rear accessories, if the use of Loctite is excluded, the best performance over time of the "connector + rear fitting" system is to apply the torque value once, then unscrew, apply the torque value a second time, then unscrew and finally apply the torque value a third time.

All dimensions are given for information only and are in mm, except as otherwise specified | *in mm: 1mm=0.03937 inch

ACCESSORIES - PROTECTIVE CAP - METAL CAPS



Description

Amphenol offers a large selection of IP68 protective caps for plugs & receptacles to protect your connector against dust, water & moisture EMI function.

Main features

- Compatible with plugs, Jam nut and Square flange receptacle.
- IP68 (permanent sealing).
- Protective against dust, water and moisture.
- EMI function.
- Nylon cord, stainless steel rope or metal chain.
- Rivet and attachment are not plated.



Military Designations - Metal Caps DLA MIL-DTL-38999 SERIES III

Series	Cap style	Material and platings	Cap size	Wire type
D38999/	32	W	15	R

1. Cap style

32	For plug
33	For receptacle

3. Cap size (same as connector size)

09	11	13	15	17	19	21	23	25
----	----	----	----	----	----	----	----	----

2. Material and platings

Shell material	Shell finish
W	Olive drab cadmium
F	Nickel ✓
Z	Black zinc nickel ✓

4. Wire type

N	Jacketed stainless steel rope and ring
R	Jacketed stainless steel rope

For other platings please consult us

Amphenol Designations - Metal Caps for 38999 Series III, TV/CTV, PowerSafe

Cap type	Cap style	Wire type	Series	Material and platings	Cap size	Deviation
B	EC	N	TV	W	15	-

1. Cap style

EC	For Square flange receptacle
ER	For Jam nut receptacle
F	For plugs
P	For in-line receptacle (only available with nylon cord)

4. Material and platings

Shell material	Shell finish
W	Olive drab cadmium
F	Aluminum
ZN	Nickel ✓
B	Black zinc nickel ✓
B	Bronze ✓
	-

2. Wire type

-	Metal chain
N	Nylon cord
R	Jacketed stainless steel rope
RO	Jacketed stainless steel rope with washer end (only for plug)

5. Cap size (same as connector size)

09	11	13	15	17	19	21	23	25
----	----	----	----	----	----	----	----	----

3. Series

TV	For MIL-DTL-38999 Series III, EN3645, TV-CTV, PowerSafe
----	---

6. Deviation

F057	For Reduced flange Jam nut receptacles
F419	Protective caps without attachment

All dimensions are given for information only and are in mm, except as otherwise specified | *in mm: 1mm=0.03937 inch

ACCESSORIES - PROTECTIVE CAP - METAL CAPS

Amphenol Designations - Metal Caps for MIL-DTL-38999 Series II, JT

1.	2.	3.	4.	5.	
Cap type	Cap style	Wire type	Series	Cap size	Material and platings
B	EC	N	JT	12	014

1. Cap style

EC	For Square flange receptacle
ER	For Jam nut receptacle
F	For plug
P	For in-line receptacle (only available with nylon cord)

2. Wire type

Blank	Metal chain
N	Nylon cord with cable tie
R	Wire rope with teflon jacket
NA	Nylon cord with eyelet

✓ : RoHS compliant

3. Series

JT	MIL-DTL-38999 Series II / JT Series
----	-------------------------------------

4. Cap size (same as connector size)

08	10	12	14	16	18	20	22	24
----	----	----	----	----	----	----	----	----

5. Material and platings

	Shell material	Shell finish
014	Aluminum	Olive drab cadmium
023		Nickel ✓
033K		Black zinc nickel ✓

Amphenol Designations - Metal Caps for MIL-DTL-38999 Series I, HE308, LJT

1.	2.	3.	4.	5.	
Cap type	Cap style	Wire type	Cable tie option	Cap size	Material and platings
B	EC	N	-	13	014

1. Cap style

EC	For Square flange receptacle
ER	For Jam nut receptacle
F	For plug
P	For in-line receptacle (only available with nylon cord)

2. Wire type

-	Metal chain
N	Nylon cord
R	Stainless Steel rope

3. Cable tie option

A	Without cable tie - plug only
Blank	Others versions

4. Cap size (same as connector size)

09	11	13	15	17	19	21	23	25
----	----	----	----	----	----	----	----	----

5. Material and platings

	Shell material	Shell finish
014	Aluminum	Olive drab cadmium
023		Nickel ✓

Military Designations - Metal Caps for HE308 UTE 93422

1.	2.	3.	4.	
Cap type	Cap style	Cap size	Material & plating	Mandatory suffix
HE308 B	00	13	7	M

1. Cap style

00	For Square flange receptacle
07	For Jam nut receptacle
06	For plug
01	For in-line receptacle (only available with nylon cord)

2. Cap size (same as connector size)

09	11	13	15	17	19	21	23	25
----	----	----	----	----	----	----	----	----

3. Material and platings

	Shell material	Shell finish
7	Aluminum	Olive drab cadmium
6		Nickel ✓

4. Mandatory suffix

M	Mandatory for all types
---	-------------------------

All dimensions are given for information only and are in mm, except as otherwise specified | *in mm: 1mm=0.03937 inch

ACCESSORIES - PROTECTIVE CAP - METAL CAPS

Overall dimensions

MIL-DTL-38999 Series III, EN3645, TV/CTV, Powersafe

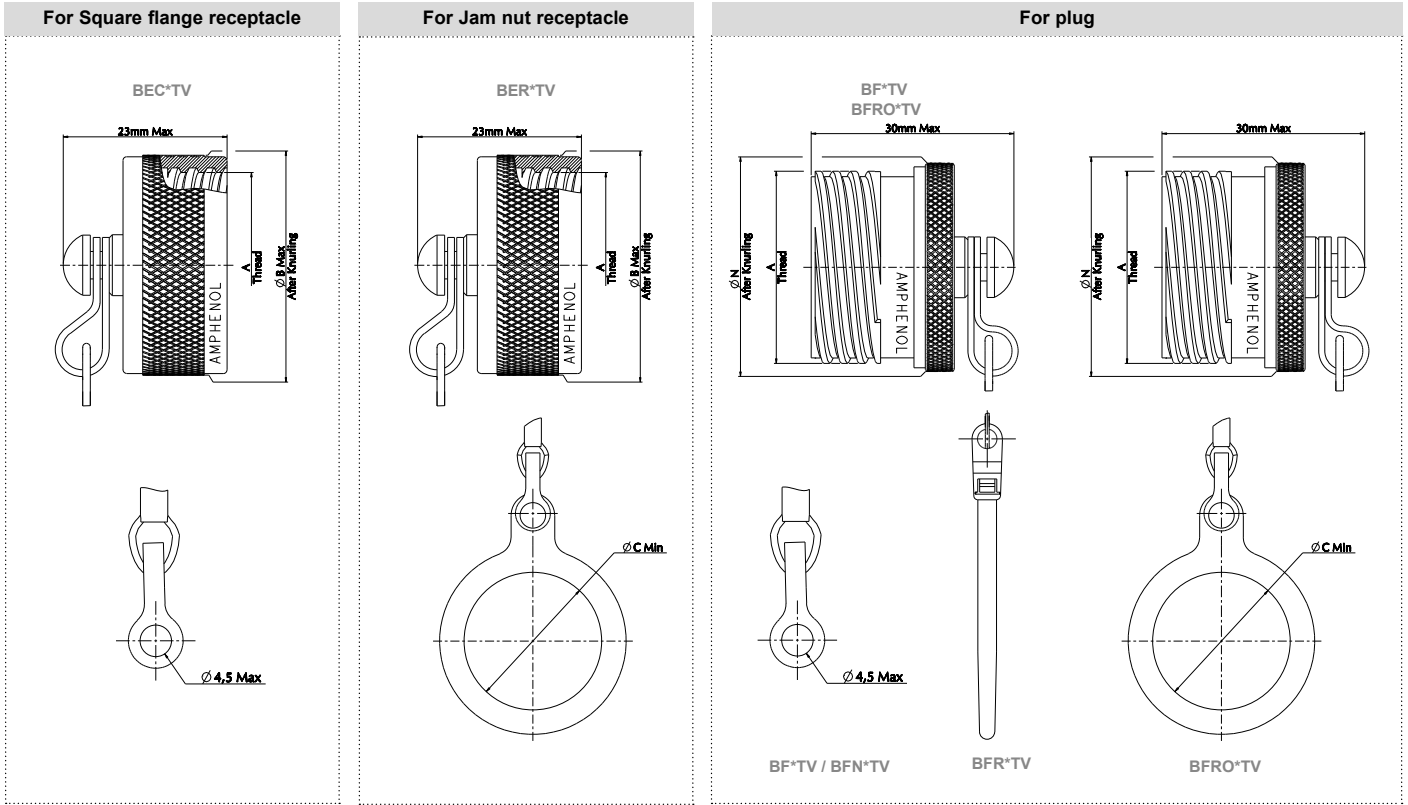

Shell size	Lanyard length		A Thread Class 2A (External) Class 2B (Internal) (inch)	ØB ^(+0.5)	ØC _{MIN}	ØN ^(-0.3)
	Plugs/in-line receptacles	Jam nut / Square Flange Receptacles				
09	160 ^{±5}	+13 127 ⁻⁷	.6250 0.1P-0.3L-TS	19.40	17.64	17.20
11			.7500 0.1P-0.3L-TS	22.60	21.97	20.50
13			.8750 0.1P-0.3L-TS	25.75	25.12	24.30
15			1.0000 0.1P-0.3L-TS	28.90	29.92	27.40
17			1.1875 0.1P-0.3L-TS	33.80	32.00	30.60
19			1.2500 0.1P-0.3L-TS	35.40	36.27	33.25
21			1.3750 0.1P-0.3L-TS	38.60	38.25	36.40
23			1.5000 0.1P-0.3L-TS	41.70	42.62	39.70
25			1.6250 0.1P-0.3L-TS	44.90	44.45	42.80

All dimensions are given for information only and are in mm, except as otherwise specified | *in mm: 1mm=0.03937 inch

ACCESSORIES - PROTECTIVE CAP - METAL CAPS

MIL-DTL-38999 Series I & II, JT, LJT & RNJ Receptacles

For Square flange receptacle		For Jam nut receptacle		For plug	
Series I BEC*	Series II BEC JT*	Series I BER*	Series II BER JT*	Series I BF*	Series II BF*JT
				Series I: BF* / BFN* Series II: BFR JT* / BFR JT*	Series I: BFNA* / BFRA* Series II: BF JT* / BFNA JT*

Shell size	Laynard length +0.1 0	ØB _{MAX}		ØC _{MAX}		ØN _{MAX}		A _{MAX} ^{+0.3} _{-0.13}	
		All caps	Series I LJT	Series II JT	Series I LJT	Series II JT	Series I LJT	Series II JT	Series I LJT
08/09	76.20	21.84	19.05	20.83	16.00	20.83	18.29	14.53	12.01
10/11		24.89	21.82	23.88	19.33	23.88	21.59	17.78	14.99
12/13		29.46	26.19	27.94	23.77	27.18	25.40	21.59	19.05
14/15		88.90	32.51	29.36	30.99	27.28	30.23	28.70	24.77
16/17	35.81		32.54	34.04	29.77	33.53	31.75	27.94	25.40
18/19	38.61		35.71	37.08	33.12	36.58	35.05	30.66	28.58
20/21	101.6	41.91	38.89	40.13	36.45	39.88	38.10	33.83	31.75
22/23		44.96	41.68	43.18	39.62	42.93	41.40	37.01	34.93
24/25		48.01	44.86	46.88	42.88	46.23	44.45	40.18	38.10

All dimensions are given for information only and are in mm, except as otherwise specified | *in mm: 1mm=0.03937 inch

Series III TVCTV
 Series II JT
 Series I LJT
 Accessories & tools
 Assembly instructions

ACCESSORIES - PROTECTIVE CAP - RUBBER CAPS

Description

Silicon protective cap against dust and water available for MIL-DTL-38999 Series I, II and III on receptacles and available for MIL-DTL-38999 III on the plug side.

Main features

- Compatible with all shell types (plugs and receptacles).
- IP67 (1meter, 30 min sealing).
- Protection against dust and water.
- Silicone 200°C.
- Nylon cord.
- Light weight and noiseless.



Amphenol Designations - Rubber caps for MIL-DTL-38999 Series I, II, III, LJT, JT, TV

1. Cap type	2. Cap style	3. Wire type	4. Series	5. Cap size
RC	00	N	TV	15

00	For Square flange receptacle
07	For Jam nut receptacle
01	For in-line receptacle
06	For plug - MIL-DTL-38999 Series III, EN3645, TV/CTV only

TV	MIL-DTL-38999 Series III, EN3645, TV/CTV, PowerSafe
JT	MIL-DTL-38999 Series II, JT - Receptacles only
LJT	MIL-DTL-38999 Series I, HE308, LJT & RNJ - Receptacles only

N	Nylon cord
---	------------

LJT/TV	9	11	13	15	17	19	21	23	25
JT	8	10	12	14	16	18	20	22	24

Overall dimensions

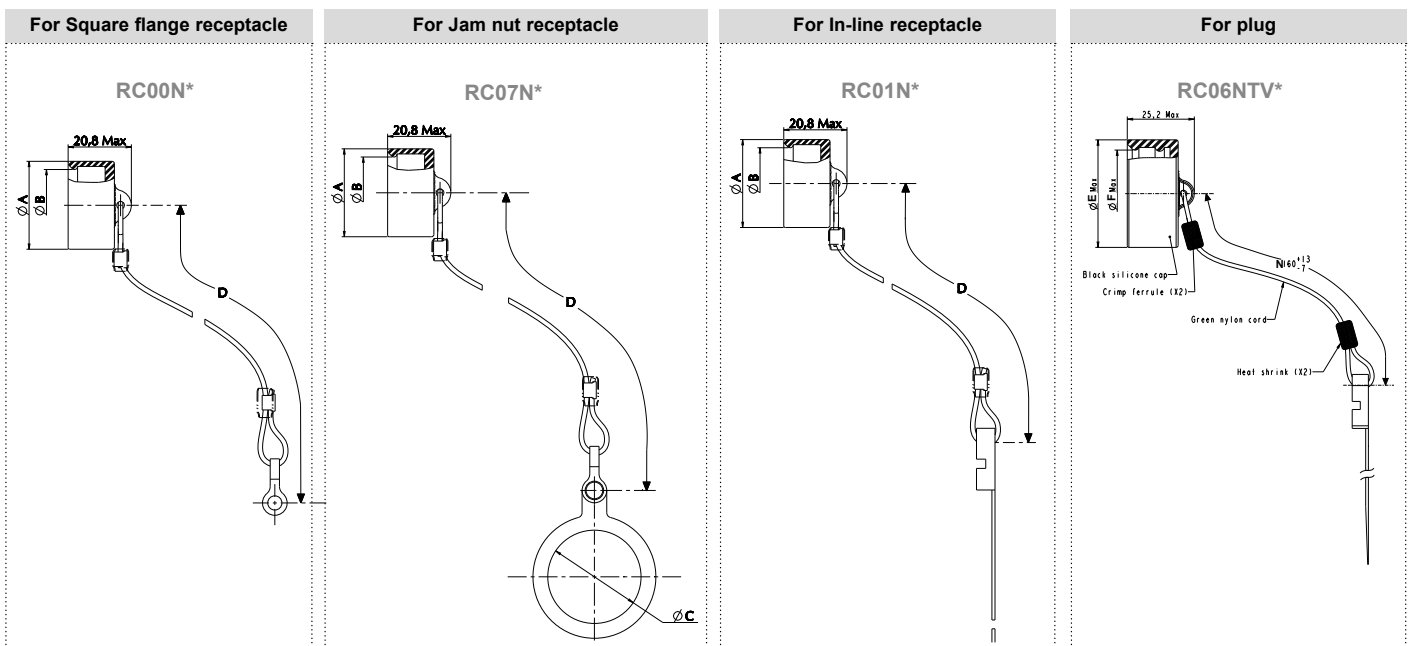

All dimensions are given for information only and are in mm, except as otherwise specified | *in mm: 1mm=0.03937 inch

ACCESSORIES - PROTECTIVE CAP - RUBBER CAPS

Overall dimensions

Receptacles - MIL-DTL-38999 Series I, II, III, EN3645, HE308, LJT, JT, TV/CTV, PowerSafe

Size	Ø C _{MAX}			Ø A _{MAX}		Ø B _{MAX}		D ⁺¹³ ₋₇		
	LJT	JT	TV	LJT / TV	JT	LJT / TV	JT	LJT	JT	TV
08/09	26.16	30.99	27	19.25	16.25	13.85	10.85	76.20	76.20	140
10/11	30.73	36.07	32	22.55	19.25	17.20	13.85			
12/13	35.56	39.37	37	25.95	22.55	20.60	17.20			
14/15	40.64	42.67	40	28.75	25.95	23.40	20.60			
16/17	43.18	45.72	44	32.75	28.75	27.40	23.40			
18/19	45.72	48.77	46	35.05	32.75	28.25	27.40			
20/21	48.77	52.07	49	37.95	35.05	31.60	28.25			
22/23	53.34	55.37	54	41.15	37.95	34.80	31.60	101.60	101.60	
24/25	55.88	58.42	56	44.30	41.15	37.70	34.80			

Plugs TV/CTV - MIL-DTL-38999 series III, EN3645, TV/CTV

Size	Ø E	Ø F	D ⁺¹³ ₋₇
9	25.25	18.75	160
11	28.00	21.40	
13	32.15	25.70	
15	36.05	29.00	
17	40.10	32.48	
19	42.82	35.20	
21	46.02	38.50	

All dimensions are given for information only and are in mm, except as otherwise specified | *in mm: 1mm=0.03937 inch

ACCESSORIES - RECEPTACLE SELF-CLOSING CAPS

Description

High end Protective with metal self-closing function for MIL-DTL-38999 series III, EN3645 & TV/CTV receptacles (not available for series I and II).

Main features

- Fast self-closing function.
- Space saving: no need for dummy receptacle.
- No noise from pending cap.
- IP67 (1meter, 30 min sealing).
- Protection against dust, water and moisture.
- EMI function.
- Compatible with Jam nut and Square flange receptacle.
- Material: Aluminum with Olive drab cadmium, Black zinc nickel, Nickel and Black electrophoresis.
- Available in several sizes, others sizes upon request.



Amphenol Designations - Self-closing Caps for 38999 Series III, EN3645, TV/CTV

Series	1. Cap style	2. Cap type	3. Cap size	4. Material and platings
TV	07	SCC	15	W

1. Cap style	
-	For Square flange receptacle
07	For Jam nut receptacle

2. Cap type	
SCC	Self-closing cap

3. Cap size					
For Square flange receptacle:					
09	11	13	15	17	19
For Jam nut receptacle:					
15			19		

4. Material and platings		
	Shell material	Shell finish
W		Olive drab cadmium
F	Aluminum	Nickel ✓
ZN		Black zinc nickel ✓
B	Bronze ✓	-

All dimensions are given for information only and are in mm, except as otherwise specified | *in mm: 1mm=0.03937 inch

ACCESSORIES - RECEPTACLE SELF-CLOSING CAPS

Overall dimensions

For Square flange receptacle

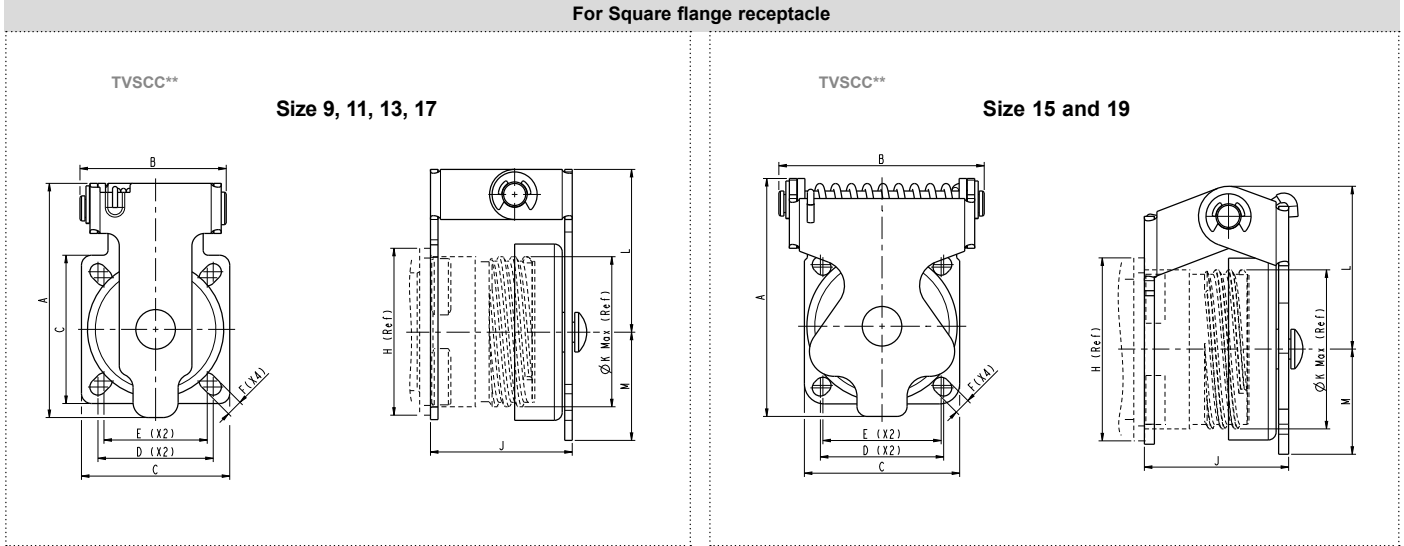

Size	A	B	C	D	E	F	H	J	ØK _{MAX}	L	M	N	ØP _{MIN}	ØQ ± 0.13
9	39.5	27.2	24.8	18.26	-		23.83		15.88	25.5	14.0	18.26	13.11	
11	43.0	27.2	27.2	20.62	18.26		26.19	31.2	19.05	27.0	16.0	20.62	15.88	
13	46.75	29.2	29.6	23.01	20.62		28.58		22.23	29.15	17.6	23.01	19.05	
15	47.5	41.0	31.0	24.61	23.61	3.25	30.96	30.9	25.4	29.5	18.0	24.61	23.01	3.25
17	54.1	33.4	34.9	26.97	-		33.32		30.16	32.5	21.6	26.97	25.81	
19	53.5	48.4	38.0	29.36	26.97		36.53	31.2	31.75	32.5	21.0	29.36	28.98	

For Jam nut receptacle

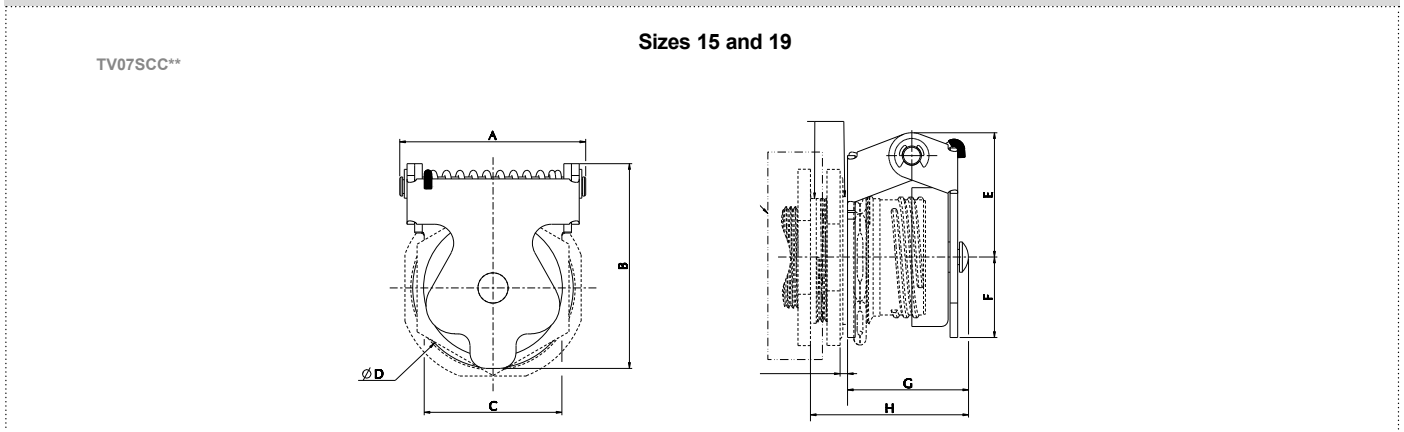

Size	A	B	C	ØD	E	F	G	H	ØK _{MIN}	L
15	41	47.5	31	35	29.5	18	30.9		28.82	27.5
19	48.4	53.5	-	42	32.5	21	31.8	35	35.16	33.86

All dimensions are given for information only and are in mm, except as otherwise specified | *in mm: 1mm=0.03937 inch

Series III TVCTV
Series II JT
Series I LJT
Accessories & tools
Assembly instructions

ACCESSORIES - PLASTIC DUST CAPS



Description

Plastic dust caps are dedicated to protection of your connectors (rear & front parts) during transportation & integration. Already integrated on the connectors BOMs, they can be re-ordered if needed.

For MIL-DTL-38999 Series III, EN3645, TV/CTV, PowerSafe, RNJLP, SC39:

Size	MIL-DTL-38999 Series III		RNJ LP		SC39	
	For plug	For receptacle	For plug	For receptacle	For plug	For receptacle
9	606062	606061	-	-	606076	606074
11	805414	606062	606061	606062	606061	606062
13	606073	606063	606062	606063	606062	606063
15	606066	606064	606063	606064	606063	606064
17	606067	606065	606064	606073	606064	606065
19	606068	606066	606073	606066	606073	606066
21	606070	606067	606066	606067	606066	606067
23	606079	606068	606067	606068	606067	606068
25	606079	606069	606068	606070	606068	606070

For MIL-DTL-38999 Series II, JT:

Size	MIL-DTL-38999 Series II	
	For plug	For receptacle
8	606061	805411
10	606062	805412
12	606064	805413
14	606073	805414
16	805416	805415
18	805418	805416
20	606068	805417
22	606069	805418
24	606079	606069

For MIL-DTL-38999 Series I, HE308, LJT, RNJ:

Size	MIL-DTL-38999 Series I		RNJ	
	For plug	For receptacle	For plug	For receptacle
9	805413	606061	-	-
11	805414	805413	606061	805413
13	606073	805414	606062	805414
15	606066	805415	606063	805415
17	606067	805416	606064	805416
19	606068	805417	606073	805417
21	606070	805418	606066	805418
23	606079	606068	606067	606068
25	606077	606078	606068	606078

All dimensions are given for information only and are in mm, except as otherwise specified | *in mm: 1mm=0.03937 inch

ACCESSORIES - STOPPER FOR PANELS



Description

Stopper for Jam nut receptacle panel holes, available in all sizes for MIL-DTL-38999 Series III, EN3645, TV/CTV to fill the panel hole and keep EMI protection of the box.

Main features

- For Jam nut receptacle panel.
- Aluminum, with Black zinc nickel or Nickel plating
- Fast and easy solution for your panel hole.
- Protective against dust, water and moisture.
- EMI function.



Overall dimensions

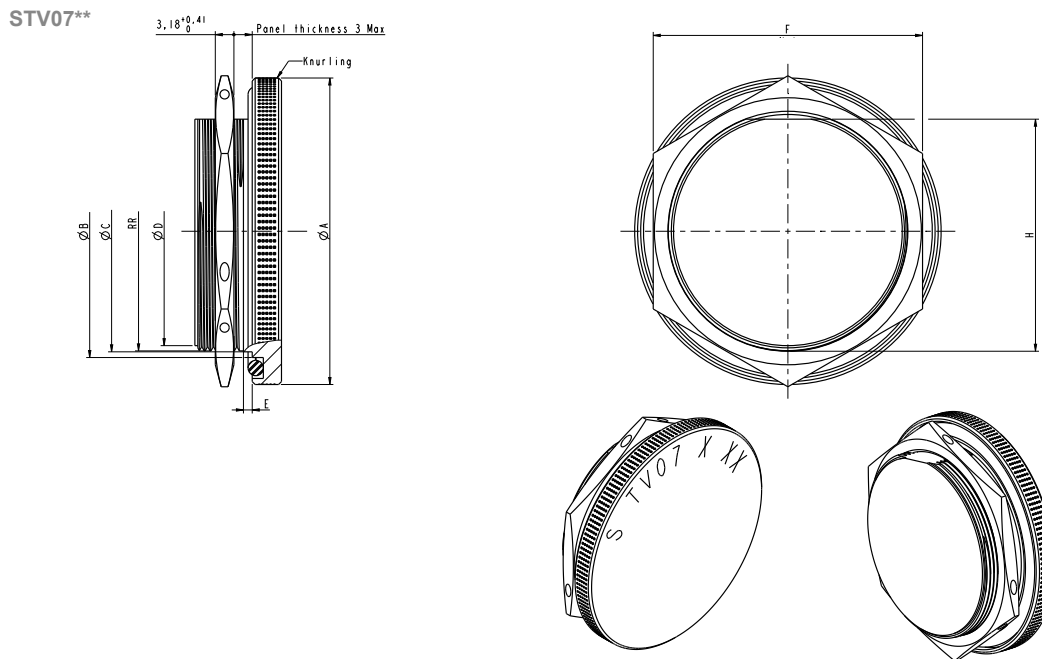

Size	ØA ±0.13	ØB ±0.13	ØC ⁰ -0.13	ØD ⁰ -0.18	ØE ⁰ -0.3	F ±0.4	RR thread-metric	H ⁰ -0.23
9	26.97	19.73	17.42	15.77	1.5	22.23	M17x1-6g	16.61
11	31.75	24.51	20.60	18.67	1.5	25.40	M20x1-6g	19.15
13	34.93	27.69	25.32	23.42	1.5	30.18	M25x1-6g	23.90
15	38.10	30.86	28.52	26.42	1.5	33.32	M28x1-6g	27.05
17	41.28	34.04	-	29.57	-	36.53	M32x1-6g	30.23
19	46.02	36.80	-	32.74	-	39.67	M35x1-6g	33.40
21	49.23	39.98	-	35.92	-	42.88	M38x1-6g	36.58
23	52.37	43.15	41.20	39.09	1.5	46.02	M41x1-6g	39.75
25	55.57	46.33	44.40	42.27	1.5	50.80	M44x1-6g	42.93

Amphenol Designations - Stopper for panel

1. Cap style	2. Material and platings	3. Cap size
S	W	15
TV07		

1. Cap style: 07 For Jam nut Panel hole - MIL-DTL-38999 Series III, EN3645, TV-CTV

3. Cap size (same as connector size): 09 11 13 15 17 19 21 23 25

2. Material and platings	
Shell material	Shell finish
W	Olive drab cadmium
F	Aluminum
ZN	Black zinc nickel ✓

All dimensions are given for information only and are in mm, except as otherwise specified | *in mm: 1mm=0.03937 inch

ACCESSORIES - OTHERS

Dummy Receptacles

Dummy receptacle to support plugs & cable harnesses while unmated or servicing



Main features

AVAILABLE IN DIFFERENT RANGES :

- LJT - MIL-DTL-38999 Series I, HE308 : Square flange
- TV - MIL-DTL-38999 Series III, EN3645 : Square flange and Jam nut
- RNJ plug and receptacle

- Rubber washers ensuring sealing when mated
- Same dimensions than the standard receptacle front part

MATERIAL AND PLATINGS : Aluminium with Olive drab cadmium, Black zinc nickel and Nickel, Stainless Steel and Bronze

Amphenol Designations - Dummy receptacles for MIL-DTL-38999 Series III

	1.	2.	3.	4.	5.
Dummy receptacle	Style	Series	Material and plating	Shell size	Coding
SE	00	TV	W	11	N

1. Dummy receptacle type

00 Square flange

2. Series

TV For MIL-DTL-38999 Series III (TV/CTV), EN3645

3. Material and platings

	Shell material	Shell finish
W		Olive drab cadmium
F	Aluminum	Nickel ✓
ZN		Black zinc nickel ✓
B	Bronze* ✓	-

*Copper aluminum alloy

4. Shell size

For MIL-DTL-38999 Series III (TV/CTV)

09	11	13	15	17	19	21	23	25
----	----	----	----	----	----	----	----	----

5. Keying

(universal)	N	A	B	C	D	E
-------------	---	---	---	---	---	---

Amphenol Designations - Dummy receptacles for MIL-DTL-38999 Series I, II

	1.	2.	3.	4.	5.
Dummy receptacle	Style	Series	Coding	Plating	Shell size
SE	00	LJT	A	023	11

1. Dummy receptacle type

00 Square flange

2. Series

LJT For MIL-DTL-38999 Series I (LJT), HE308, RNJ

JT For MIL-DTL-38999 Series II (JT)

3. Keying

(universal)	N	A	B	C	D	E
-------------	---	---	---	---	---	---

4. Material and platings

	Shell material	Shell finish
014		Olive drab cadmium
023	Aluminum	Nickel ✓
033K		Black zinc nickel ✓

5. Shell size

For Series I (LJT), HE308, RNJ

09	11	13	15	17	19	21	23	25
----	----	----	----	----	----	----	----	----

For MIL-DTL-3899 Series II (JT)

08	10	12	14	16	18	20	22	24
----	----	----	----	----	----	----	----	----

All dimensions are given for information only and are in mm, except as otherwise specified | *in mm: 1mm=0.03937 inch

ACCESSORIES - OTHERS

Square flange receptacles panel gaskets

For MIL-DTL-38999 SERIES I, II and III
 - 0,8mm thickness
 - Elastomer 31B6, NFL 17-131A Compliant

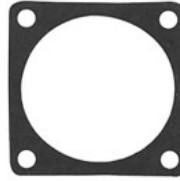

Square flange receptacle panel gaskets (thickness 0.8 mm)	HE308 reference
JE 09/10	HE308 J00-09M
JE 11/12	HE308 J00-11M
JE 13/14	HE308 J00-13M
JE 15/16	HE308 J00-15M
JE 17/18	HE308 J00-17M
JE 19/20	HE308 J00-19M
JE 21/22	HE308 J00-21M
JE 23/24	HE308 J00-23M
JE 25/26	HE308 J00-25M

Supplied with LJT 00 / HE308 00 Square flange receptacles.

Holding supports

Holding support equipped with Olive drab cadmium Dummy receptacles with universal keyway.



References:

For MIL-DTL-38999 Series I: **809 891**

For MIL-DTL-38999 Series II: **809 893**

For MIL-DTL-38999 Series III: **809 931**

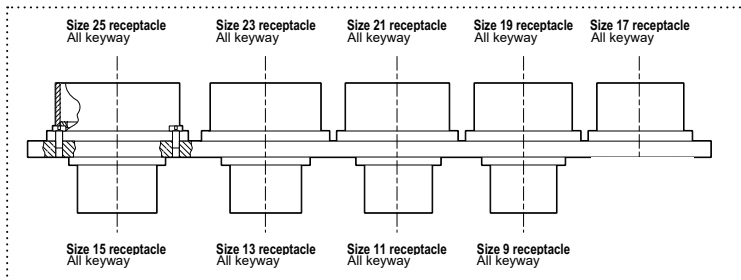

All dimensions are given for information only and are in mm, except as otherwise specified | *in mm: 1mm=0.03937 inch

CONTACT ASSEMBLY - CONTACT CRIMPING



Videos available to help you on our website www.amphenol-socapex.com/en/videos

Wire stripping

- 1 Strip wire to required length. (See stripping dimensions table below). When using hot wire stripping, do not wipe melted insulation material on wire strands; with mechanical strippers do not cut or nick strands.
- 2 See table 1 for proper finished outside wire dimensions.
- 3 Twist strands together to form a firm bundle.
- 4 Insert stripped wire into contact applying slight pressure until wire insulation butts against wire well. Check inspection hole to see that wire strands are visible. If there are strayed wire strands, entire wire end should be re-twisted.
When wire is stripped and properly installed into contact, the next step is to crimp the wire inside the contact by using the proper crimping tool.



Stripping dimension

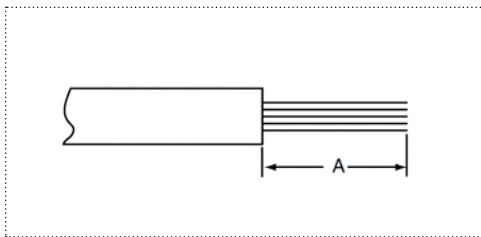

Contact size	Stripping length
23 ^{HD}	4
22D	4
20	6
16	6
12	6

Contact size	Table 1 Wire Dimension (Inches)**	
	Min.	Max.
10	.135	.162
12	.097	.142
16	.065	.109
20	.040	.077
22	.034	.060
22M, 22D	.030	.050

Contact crimping

Select the recommended crimping tool, turret head or positioner selection settings according to contact size, part number and wire gauge size.

- 1 Insert stripped wire into contact crimp pot. Wire must be visible through inspection hole.
- 2 Using correct crimp tool and locator, cycle the tool once to be sure the indentors are open. insert contact and wire into locator. Squeeze tool handles firmly and completely to insure a proper crimp. The tool will not release unless the crimp indentors in the tool head have been fully actuated.
- 3 Release crimped contact and wire from tool.
Be certain the wire is visible through inspection hole in contact.

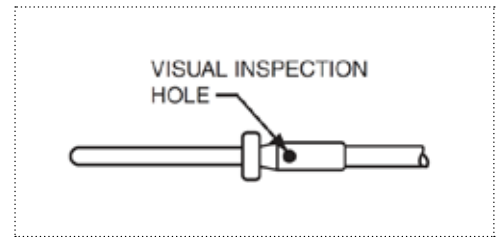

^{HD} High density 38999.

CONTACT ASSEMBLY - CONTACT INSERTION & REMOVAL



Videos available to help you on our website www.amphenol-socapex/videos

- Contact Insertion Instructions
- Contact Crimping Instructions
- Quadrax, Twinax and Coax contacts

Contact insertion

Note: All plastic tools are double-ended. The colored side is the insertion tool and the white side is the removal tool.

1 First remove hardware from the plug and receptacle and slide the hardware over wires in proper sequence.

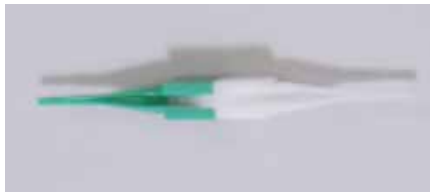
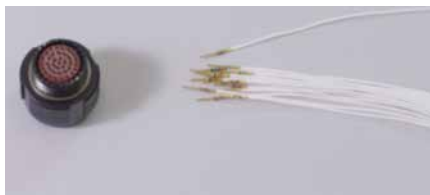

2 Use proper plastic or metal insertion tool for corresponding contact. (Consult insertion tool table "Crimping tool"). Slide correct tool (with plastic tool use colored end) over wire insulation and slide forward until tool bottoms against rear contact shoulder.

Plastic tool with contact in proper position



Metal tool



3 Next align the tool and contact up to the properly identified cavity at rear of connector plug. Use firm, even pressure; do not use excessive pressure. It is recommended to start at the center cavity. Contact must be aligned with grommet hole and not inserted at an angle. Push forward until contact is felt to snap into position within insert.



CAUTION. when inserting or removing contacts. do not spread or rotate tool tips

4 Remove tool and pull back lightly on wire, making sure contact stays properly seated and isn't dragged back with the tool. Repeat operation with remainder of contacts to be inserted, beginning with the center cavity and working outward in alternating rows.



5 After all contacts are inserted, fill any empty cavities with wire sealing plugs.



6 Reassemble plug or receptacle hardware - slide forward and tighten using connector pliers. Connector holding tools are recommended while tightening back accessories. When using strain relief, center wires at bar clamp. Slide clamp grommet into position and tighten clamp bar screws. When tightening screws, pressure should be applied in the same direction that clamp is threaded to rear threads of connector. When not using clamp grommet, build up wire bundle with vinyl tape so clamp bar will maintain pressure on wires.

Contact removal

Note: All plastic tools are double-ended. The colored side is the insertion tool and the white side is the removal tool.

1 Remove hardware from plug or receptacle and slide hardware back along wire bundle.



2 Use proper plastic or metal removal tool for corresponding contact. Slide correct size tool over wire insulation.



3 Insert plastic or metal removal tool into contact cavity until tool tips enter rear grommet and come to a positive stop. Hold tool tip firmly against positive stop on contact shoulder. Grip wire and simultaneously remove tool and contact. (On occasion, it may be necessary to remove tool, rotate 90° and reinsert.)



Series III TVCTV
Series II JT
Series I LJT
Accessories & tools
Assembly instructions

CONTACT ASSEMBLY - CONTACTS, TOOLING & ACCESSORIES

Amphenol offers a wide range of contacts and dedicated tools & accessories. For more information please consult the Contacts Catalog (DOC-000081-ANG)



Standard Crimp contacts & Crimping tools

PIN or SOCKET	MILITARY Nb	CONTACT		AMPHENOL P/N	BIN Color Code			CONNECTOR MIL-DTL-38999			Crimping Tool	
		Mating end size	Wire barrel size		1st	2nd	3rd	S I	S II	S III	Crimping tool	Positionner
P	M39029/18-177	23	22	900049	Orange	Blue	Black			X	M22520/2-01	M22520/2-13
	M39029/58-360	22	22D	900004	Orange	Blue	Black	X	X	X	M22520/2-01	M22520/2-09
	M39029/58-363	20	20	900001	Orange	Blue	Black	X	X	X	M22520/2-01	M22520/2-10
	M39029/58-364	16	16	900000	Orange	Blue	Black	X	X	X	M22520/1-01	M22520/1-04
	M39029/58-365	12	12	900005	Orange	Blue	Black	X	X	X	M22520/1-01	M22520/1-04
S	M39029/17-172	23	22	900048	Orange	Blue	Black			X	M22520/2-01	M22520/2-16
	M39029/56-348	22	22D	900044	Orange	Blue	Black	X		X	M22520/2-01	M22520/2-07
	M39029/57-354	22	22D	900014	Orange	Blue	Black		X		M22520/2-01	M22520/2-06
	M39029/56-351	20	20	900041	Orange	Blue	Black	X		X	M22520/2-01	M22520/2-10
	M39029/57-357	20	20	900011	Orange	Blue	Black		X		M22520/2-01	M22520/2-10
	M39029/56-352	16	16	900040	Orange	Blue	Black	X		X	M22520/1-01	M22520/1-04
	M39029/57-358	16	16	900010	Orange	Blue	Black		X		M22520/1-01	M22520/1-04
	M39029/56-353	12	12	900045	Orange	Blue	Black	X		X	M22520/1-01	M22520/1-04
	M39029/57-359	12	12	071315	Orange	Blue	Black		X		M22520/1-01	M22520/1-04

Power contacts - Size 8

PIN or SOCKET	Contact		Amphenol P/N	Crimping Tool	Piggy Back Grommet
	Mating end size	Wire barrel size			
P	8	8	900197 900198*	M300-BT with SP593 (supplied by DMC Tools)	900471
S	8	8	900217		

*Compatible with 21-48 contact arrangement only P

Dummy Contacts

Contact size	Dummy contact material	Proprietary No
4	White plastic	900329
8	Green plastic	900488
8	Brass + gold finish	900183
8	White plastic (recommended)	900029
12	Brass + gold finish	900025
12	White plastic	900486
16	Brass + gold finish	900028
16	Blue plastic	900026
20	Brass + gold finish	900332

Metal dummy contacts are recommended for applications requesting EMI protection.

Sealing plugs

Contact size	Proprietary No	Military No
8 power	900024	-
12	900023	MS27488-12-2
16	900020	MS27488-16-2
20	900021	MS27488-20-2
22D	900022	MS27488-22-2
23	900022	MS27488-22-2

All dimensions are given for information only and are in mm, except as otherwise specified | *in mm: 1mm=0.03937 inch

CONTACT ASSEMBLY - CONTACTS, TOOLING & ACCESSORIES

Insertion and removal tools

Plastic tools



Contact size	Insertion tool		Removal tool		Colour	
	Proprietary No	Military No	Proprietary No	Military No	Insertion	Extraction
8 Power/coax	*	*	-	M81969/14-12	-	green
12	809 859	M81969/14-04	809 859	M81969/14-04	yellow	white
16	809 855	M81969/14-03	809 855	M81969/14-03	blue	white
20	809 854	M81969/14-10	809 854	M81969/14-10	red	orange
22D	809 856	M81969/14-01	809 856	M81969/14-01	green	white

* Manual insertion

Metallic tools



Contact size	Straight type		Angle type			
	Insertion tools Proprietary No	Removal tools Proprietary No	Insertion tools		Removal tools	
			Proprietary No	Military No	Proprietary No	Military No
4	*	809943	-	-	-	-
8 Power/coax	-	809961	*	*	809 845	M81969/8-14
12	-	-	809 838	M81969/8-09	809 839	M81969/8-10
16	809 816	809 846	809 812	M81969/8-07	809 820	M81969/8-08
20	809 817	809 847	809 813	M81969/8-05	809 821	M81969/8-06
22D	809 819	809 849	809 815	M81969/8-01	809 823	M81969/8-02
23	810 010	810 010	-	-	-	-

* Manual insertion

All dimensions are given for information only and are in mm, except as otherwise specified | *in mm: 1mm=0.03937 inch

MIL-DTL-38999 SERIES III & EN3645, TV/CTV - CROSS REFERENCES

Please remember that these references are not strictly the same: some production test or dimensions can be different regarding the standard they are compliant too. Please refer to the MIL-DTL-38999 SERIES III, EN3645, TV/CTV section for more informations, *page 52*.

Material	Shell style	Plating	Military	ASD-STAN	Amphenol
Composite	Wall mount receptacle	Olive drab cadmium	D38999/20J*A D38999/20J*B D38999/20J*P D38999/20J*S	EN3645J0*N *A EN3645J0*N *B EN3645J0*N *M EN3645J0*N *F	CTVP00RW*P*LC CTVP00RW*S*LC CTVP00RW*P* CTVP00RW*S*
		Nickel	D38999/20M*A	EN3645M0*N *A	CTVPS00RF*P*LC
	Jam nut receptacle	Olive drab cadmium	D38999/24J*A	EN3645J7*N *A	CTV07RW*P*LC
		Nickel	D38999/24M*A	EN3645M7*N *A	CTVS07RF*P*LC
	Straight plug	Olive drab cadmium	D38999/26J*A	EN3645J6*N *A	CTV06RW*P*LC
		Nickel	D38999/26M*A	EN3645M6*N *A	CTVS06RF*P*LC
Aluminum	Wall mount receptacle	Olive drab cadmium	D38999/20W*A D38999/20W*B D38999/20W*P D38999/20W*S	EN3645W0*N *A EN3645W0*N *B EN3645W0*N *M EN3645W0*N *F	TVP00RW*P*LC TVP00RW*S*LC TVP00RW*P* TVP00RW*S*
		Nickel	D38999/20F*A	EN3645F0*N *A	TVPS00RF*P*LC
		Black zinc nickel	D38999/20Z*A		TVP00ZN*P*LC
		Durmalon	D38999/20T*A		TVP00DT*P*LC
	Jam nut receptacle	Olive drab cadmium	D38999/24W*A	EN3645W7*N *A	TV07RW*P*LC
		Nickel	D38999/24F*A	EN3645F7*N *A	TVS07RF*P*LC
		Black zinc nickel	D38999/24Z*A		TV07ZN*P*LC
		Durmalon	D38999/24T*A		TV07DT*P*LC
	Straight plug	Olive drab cadmium	D38999/26W*A	EN3645W6*N *A	TV06RW*P*LC
		Nickel	D38999/26F*A	EN3645F6*N *A	TVS06RF*P*LC
		Black zinc nickel	D38999/26Z*A		TV06ZN*P*LC
		Durmalon	D38999/26T*A		TV06DT*P*LC
Stainless steel	Wall mount receptacle	Passivated	D38999/20K*A D38999/20K*B D38999/20K*P D38999/20K*S	EN3645K0*N *A EN3645K0*N *B EN3645K0*N *M EN3645K0*N *F	TVPS00RK*P*LC TVPS00RK*S*LC TVPS00RK*P* TVPS00RK*S*
		Nickel plated	D38999/20S*A		TVPS00RS*P*LC
		Passivated	D38999/24K*A	EN3645K7*N *A	TVS07RK*P*LC
		Nickel plated	D38999/24S*A		TVS07RS*P*LC
	Straight plug	Passivated	D38999/26K*A	EN3645K6*N *A	TVS06RK*P*LC
		Nickel plated	D38999/26S*A		TVS06RS*P*LC





NOTES

A series of horizontal dotted lines for taking notes, spanning the width of the page below the 'NOTES' header.

ABOUT AMPHENOL

Founded in 1932, **Amphenol** is one of the largest manufacturers of interconnect products in the world. The company designs, manufactures, and markets electrical, electronic, and fiber optic connectors, interconnect systems, and coaxial and specialty cables.

Amphenol has a diversified presence as a leader in high growth areas of the interconnect industry and provides solutions for customers in the automotive, broadband, industrial, information technology and data communications, military and aerospace, mobile devices, and mobile networks markets.

More info on www.amphenol.com

Amphenol
ENABLING THE ELECTRONICS REVOLUTION

Europe

FRANCE	Amphenol AIR LB	2 rue Clément Ader, ZAC de Wé - 08110 Carignan	+33 3 24 22 78 49
FRANCE	Amphenol SEFEE	Z.I. des Cazes – BP243 - 12402 Saint-Affrique Cedex	+33 5 65 98 11 00
GERMANY	Amphenol AIR LB GMBH	Am Kleinbahnhof 4 - 66740 Saarlouis	+49 6831 981 00
ITALY	Amphenol EUROPEAN SALES OPERATIONS	Via Barbaiana n.5 - 20020 Lainate - Milano	+39 293 254 214
UNITED KINGDOM	Amphenol INVOTEC	Unit 1-3, Hedging Lane Industrial Estate, Dosthill - Tamworth, B77 5HH	+44 1827 263 000
UNITED KINGDOM	Amphenol IONIX SYSTEMS	Prospect House, Taylor Business Park, Risley, Warrington, WA3 6HP	+44 1 942 685 200
UNITED KINGDOM	Amphenol LTD	Thanet Way, Whitstable - KENT, CT53JF	+44 1227 773 200
UNITED KINGDOM	Amphenol MARTEC	St Augustines Business Park, Swalecliffe Whitstable - Kent CT5 2QJ	+44 1227 793 733

North America

CANADA	Amphenol CANADA	605 Milner avenue - Toronto, Ontario	+1 416 291 0647
USA	Amphenol AEROSPACE OPERATIONS	40-60 Delaware street - Sidney, NY 13838	+1 800 678 0141
USA	Amphenol BORISH TECHNOLOGIES	4511 East Paris AVE - Grand Rapids, MI 49512	+1 616 554 9820
USA	Amphenol FSI	1300 Central Expwy N, Suite 100 - Allen, TX 75013	+1 214 547 2400
USA	Amphenol GRIFFITH ENTERPRISES	6000 East Coury Drive - Cottonwood, AZ 86326	+1 928 634 3685
USA	Amphenol NEXUS TECHNOLOGIES	50 Sunnyside Avenue - Stamford, CT 06902	+1 203 327 7300
USA	Amphenol PCD	72 Cherry Hill Drive - Beverly, MA. 01915	+1 978 624 3400
USA	Amphenol PRINTED CIRCUIT	Board Technology, 91 Northeastern Boulevard - Nashua, NH 03062	+1 603 324 4500
USA	Amphenol SV MICROWAVE	2400 Centrepark West Drive - West Palm Beach, FL	+1 561 840 1800
USA	Amphenol TIMES MICROWAVE	358 Hall Avenue - Wallingford, CT 06492	+1 800 867 2629

Asia

CHINA	Amphenol PCD CO.	Building 21, 1 st Liao Keng Industrial Zone, Shi Yan Street - Bao An District - Shenzhen 518108	+86 755 8173 8000/8286
INDIA	Amphenol INTERCONNECT INDIA	105 Bhosari Industrial Area - Pune 411 026	+91 20 27120363
JAPAN	Amphenol JAPAN	471-1, Deba, Ritto-City - Shiga 520 3041	+81 77 553 8501
KOREA	Amphenol DAESHIN	558 SongNae-Dong SoSa-Gu, Bucheon-city, Kyunggi-Do - 420-130	+81 32 610 3830/3845
SINGAPORE	Amphenol EAST ASIA	26/F, Railway Plaza, 39 Chatham Road South, Tsim Sha Tsui, Kowloon, Hong Kong	+65 6294 2128

Other Areas

AFRICA	Amphenol AFRICA	30 Impala Rd - Sandton 2146	+27 82 410 5179
ARGENTINA	Amphenol ARGENTINA	Av. Callao 930 2do piso Oficina B "Plaza" C1023 - AAP Buenos Aires	+54 11 4815 6886
AUSTRALIA	Amphenol AUSTRALIA PTY	2 Fiveways Blvd., Keysborough - Melbourne - Victoria 3173	+61 3 8796 8888
BRAZIL	Amphenol DO BRAZIL	Rua Diogo Moreira, 132, 20 andar, rooms 2001-2-3	+55 11 3815 1003
ISRAEL	Amphenol BAR-TEC	3 Hagavish Street, K fir-Barkan Bldg. East Industrial Zone - Kfar-Sava, 44102	+972 9 764 4100
MEXICO	Amphenol OPTIMIZE	Carretera Internacional Km 6.5, Col. Parque Industrial, Nogales, Sonora, C.P. 84094	+52 631 311 160
NEW ZEALAND	Amphenol PHITEK	Level 4, 2 Kingdon Street, Newmarket, Auckland 1023	+64 9 524 2984
RUSSIA	Amphenol RUSSIA	Yaroslavskaja Street 8 - 129164 Moscow	+7 495 937 6341
TURKEY	Amphenol TURKEY	Sun Plaza 15 Kat: 15 Maslak Hah. Bilim Sok. No.5 - Sisli/Istanbul, 34398	+90 212 367 92 19

Amphenol SOCAPEX



Amphenol Socapex

948, promenade de l'Arve BP29
74311 Thyez Cedex - France
+33 (0)4 50 89 28 00
contact@amphenol-socapex.fr
www.amphenol-socapex.com



For Technical Support

+33 (0)4 50 89 28 49
technicalsupport@amphenol-socapex.fr



To buy our products

+33 (0)4 50 90 28 00
contact@amphenol-socapex.fr
www.amphenol-socapex.com/amphenol/sales
Request a quote online at www.amphenol-socapex.com/quotation_request



Documentation

www.amphenol-socapex.com/documentation
To order a paper version of our catalogs, send an e-mail to communication@amphenol-socapex.fr

Check our product
inventory



Product Selectors
& 3D Files



www.amphenol-socapex.com

Follow Amphenol Socapex on social media :



This catalog uses paper from managed forests, PEFC & FSC labels, and is printed by a printer certified "Imprim'Vert®"

We reserve the right to modify our products in any way we deem necessary.

Any duplication is prohibited, unless approved in writing.

DOC-000035-ANG - June 2024
Designed by Amphenol Socapex

X-ON Electronics

Largest Supplier of Electrical and Electronic Components

Click to view similar products for [Circular MIL Spec Connector](#) category:

Click to view products by [Amphenol](#) manufacturer:

Other Similar products are found below :

[89075GULPR](#) [0025-262-542](#) [0025-263-3014](#) [0025-264-3014](#) [0031-065-002](#) [0031-071-002](#) [58-570121-04S](#) [58-584653-12P](#) [0134-201-1007](#)
[0134-202-0800](#) [0134-202-1200](#) [0134-202-2407](#) [0134-207-1206](#) [0134-207-1800](#) [0134-207-2207](#) [0134-213-0806](#) [0134-213-1007](#) [0134-213-1009](#) [0134-213-1200](#) [0134-213-1208](#) [0134-213-1800](#) [0134-213-2209](#) [0025-258-000](#) [0025-259-542](#) [0031-066-002](#) [0031-068-002](#) [0031-069-002](#) [0031-070-002](#) [0031-072-002](#) [015-9516-002](#) [020313-0043](#) [020340-0009](#) [020418-0036](#) [020419-0080](#) [020419-0120](#) [020420-0108](#) [60-042217-10P](#) [0104-201-2402](#) [0114-201-1278](#) [024251-0015](#) [602GB06EG1832SN](#) [0134-201-1207](#) [0134-201-1410](#) [0134-201-1806](#) [0134-201-2006](#) [0134-201-2007](#) [0134-201-2010](#) [0134-201-2200](#) [0134-202-1400](#) [0134-207-0809](#)