

INDUSTRIAL@AMPHENOL
TRUSTED GLOBALLY

Amphenol Audio, USA
Amphenol Sine Systems, USA
Amphenol Tuchel Industrial, Germany



Featuring Radsok® Technology

eco | mate[®] rm

Rugged Metal Shielded Connectors

RELIABLE SIGNAL AND POWER SOLUTIONS



www.amphenol-sine.com | +1 800 394 7732

We Are Amphenol

Global Interconnect Solution Supplier

For over 80 years Amphenol has enjoyed success as the interconnection technology provider of choice to industry leading companies around the world. Our organization works with leading manufacturers across a wide range of applications - including Energy Generation & Distribution, Transportation, Heavy Equipment, Factory Automation, Wireless Outdoor, Information Technology and Data Communications Equipment, Mobile Devices, Mobile Networks, Broadband Communication, Military and Commercial Aerospace, Industrial, Automotive and Chip Card Readers - enabling smarter, faster and better technologies to connect products to customer solutions.

Our engineers design innovative combinations of industry standard connectors and application specific shielding components to create assembly systems that set the standards for performance, reliability, and cost effectiveness. Our engineering, materials, and manufacturing organizations meet the high standards imposed by ISO 9001:2008 as well as many customer specific quality systems. Our performance has earned us ship to stock and world class performance awards from many major OEMs.

We are one of the largest interconnect solution suppliers in the world and supply a wide range of product solutions globally. The industrial market footprint of Amphenol covers more than 30 countries.



eco|mate[®] rm

Rugged Metal Shielded Connectors

Table of Contents

We Are Amphenol

Global Interconnect Solution Supplier	3
---------------------------------------	---

Connector Guide

Introduction to eco mate [®] rm	6
Typical Applications	7
Series Overview	8
Connector Configurations	10
Insert Arrangements	12
General Technical Characteristics	14
GuardSafe [™] Locking Clips	16
Connector Kits	17

Connector Solutions

1 POSITION 86A / 630V	179
1 POSITION 120A / 630V	183
1 POSITION 120A - 180A / 630V	187
1 POSITION 120A - 300A / 630V	191
3 POSITIONS 13A / 300V	21
3 POSITIONS 86A / 630V	197
4 POSITIONS 13A / 300V	29
4 POSITIONS 23A / 350V	55
4 POSITIONS 45A / 500V	63
4 POSITIONS MIX 13A & 5A / 350V	37
4 POSITIONS MIX 23A & 13A / 350V	47
6 POSITIONS 5A, 7.5A / 150V	71
8 POSITIONS 13A / 250V	79
8 POSITIONS 13A / 300V	87
8 POSITIONS 23A / 375V	95
9 POSITIONS MIX 23A & 13A / 250V	103
10 POSITIONS 5A, 7.5A / 150V	111
12 POSITIONS 13A / 300V	119
19 POSITIONS 5A, 7.5A / 150V	127
19 POSITIONS 13A / 300V	135
23 POSITIONS 13A / 300V	143
26 POSITIONS 5A, 7.5A / 150V	151
28 POSITIONS 13A / 300V	159
32 POSITIONS 5A, 7.5A / 150V	167
48 POSITIONS 13A / 300V	175

Contacts

Contact Overview	200
Plating and Bulk Order Options	201
Stamped & Formed Crimped Contact Part Numbers	202
PCB Contacts	204
PCB Contacts Dimensions	206
Machined Standard Crimp Contact Part Numbers	207
RADSOK [®] Contacts	209

Table of Contents (con't)

Tooling

Machined	212
Stamped & Formed	212
Contact Extraction Tool	212
Contact Extraction Tool Table	213
Contact Extraction Tool Instruction	214

Assembly Instructions

Jam Nut Assembly and Installation Instructions	215
Flange Assembly and Installation Instructions	216
eco mate [®] rm Standard Product Straight Plug and Receptacle Cable Assembly	217
eco mate [®] rm Standard Product Straight Plug and Receptacle with End Cap	219
eco mate [®] rm Standard Product Right Angle Plug and Receptacle Cable Assembly	220
eco mate [®] rm with RADSOK [®] Straight Plug Cable Assembly	222
eco mate [®] rm with RADSOK [®] Straight Plug - Shell Size 12 Cable Assembly	223
eco mate [®] rm with RADSOK [®] 90° Plug Cable Assembly	224

Technical Data

RADSOK [®] Product Overview	226
RADSOK [®] Advantages and Custom Developed Solutions	227
RADSOK [®] Series Rated Current and Working Voltage	228
RADSOK [®] Series Dynamic Overload Tests at Different Temperatures	229
eco mate [®] rm Rated Current and Working Voltage	230
UL94 + UL1977 Industry Standards	231
IP Codes	232
Crimp Connection	233
Composition and Dimensions of Copper Wires	234
Reduction Values	235
Voltage Grading of Connectors	236
Creepage Distance	237

Appendix

Glossary of Terms	239
Part Number Index	241

Introduction to eco|mate[®] rm

Quick Reliable Mating

Bayonet Coupling

With a quick twist of the bayonet coupling system, these connectors provide positive tactile feedback to insure confident mating. This feature also reduces time and labor during installation.

Economical and Flexible

Mixed Power & Signal Layouts

Power and signal contacts can be combined in a variety of inserts providing a highly flexible interconnect solution to reduce system complexity and minimize installation costs.

Waterproof

IP67

Ideal for temporary submersion, (achieving IP67) where water and dust protection are needed.

Corrosion Resistant

Salt Spray Standard Nickel 48 Hours, Black or Green Zinc 96 Hours

Designed to withstand climate ingress and exposure to salt spray or a corrosive atmosphere while still maintaining mechanical and electrical functionality.

Wide Ranging Contact System

Flexible Contact Solutions

Our contact system offers the flexibility of using a wide variety of contact styles and wire gauges within various connectors, shell sizes and insert layouts, providing customers with a total solution.

eco|mate[®] rm

Rugged Metal Shielded Connectors

Typical Applications



Instrumentation Measurement



Robotics - Machine Tools



Building Automation & Control



Telecom -Data Infrastructure



Welding



Medical



Aerospace



Energy - Power



Military



Automotive



Off Road - Mining - Railway



Electric Vehicles

eco|mate® rm

Rugged Metal Shielded Connectors



Series Overview

The eco|mate® rm series is the connector of choice wherever there are demanding interconnect architectures. The multi-way connectors are available in 7 shell sizes and 25 insert arrangements with a variety of wire gauge options. It is the high performance, cost effective solution of choice for our customers.

The series includes two kinds of connectors: Standard Products and High Amperage. Standard Products are widely used, standardized connectors, while the High Amperage connectors are designed to endure large currents and high voltage. Typically used within hybrid electric vehicles, High Amperage connectors are available in single pole, high power arrangements featuring RADSOK® technology. RADSOK® products are offered exclusively by Amphenol. Custom developed solutions are available in both styles.

Our eco|mate® rm products are designed to be a competitive alternative to other industry standard products while maintaining the best possible mechanical and environmental quality on the market. Our eco|mate® rm products feature IP67 environmental sealing qualities, rugged

nickel plated aluminum outer shells and bayonet locking systems that require only a 1/3 turn. An audible locking “click” indicates proper installation.

The versatility of having three available contact styles allows for a broad variety of insert arrangements.

- Machined
- Stamped & Formed
- Power

The eco|mate® rm Standard Product is our standard rugged metal shielded circular connector series available in 7 shell sizes and multiple insert arrangements.

The high amperage eco|mate® rm with RADSOK® technology is our single pole power connector series ranging from 86A to 300A.

eco|mate® rm industrial grade circular connectors are manufactured to be intermateable with other industry standard connectors. All connectors are RoHS compliant. The eco|mate® rm Series meets the standards of UL1977. The file number is E339831.



eco | mate® rm Standard Products
starting on page 21

eco | mate® rm Standard Products

- Suitable For Indoor and Outdoor Applications
- EMI/RMI Shielding Capability with Appropriate Backshell
- Operating Temperature: -40°C to +105°C
Operating Temperature: -40°C to +125°C
(for parts with a silicone seal, ending in 03)
- 500 Mating Cycles
- Contacts and Cord Grips Ordered Separately
- High-Density Contact Arrangements Available
- UL ECBT2 Certified



eco | mate® rm High Amperage Products
starting on page 179

High Amperage eco | mate® rm with RADSOK® Technology

- Single Pole High Power Arrangements
- 3.6mm-10mm Contact Sizes
- Operating Temperature: -40°C to +125°C
- RoHS Compliant
- 4 Shell Sizes
- Operating Voltage: 630V
- Current Rating at 25°C: 86A-300A
- Flammability Rating: UL94-V0
- High Reliability
- Low Contact Engagement / Separation Forces
- Low Contact Resistance
- High Mating Cycle Durability

eco|mate[®] rm

Rugged Metal Shielded Connectors

Connector Configurations

End Cap for Individual Wire Sealing



Short Cable Gland



Long Cable Gland



Right Angle Cable Gland



Overmolded



Choice of Contacts

- Machined
- Stamped and Formed



Plug



Custom Solutions Available For:

- Various Applications
- Extreme Environments
- Reducing the Number of Suppliers
- Molded Strain Relief
- Minimize Stress on Conductors
- 360 ° Shielding Available
- Custom Logo
- Enhanced Sealing Properties

Contact the Factory to learn more

eco|mate[®] rm Series



Plug Kit includes Connector, Backshell and Contacts

Connector Guide



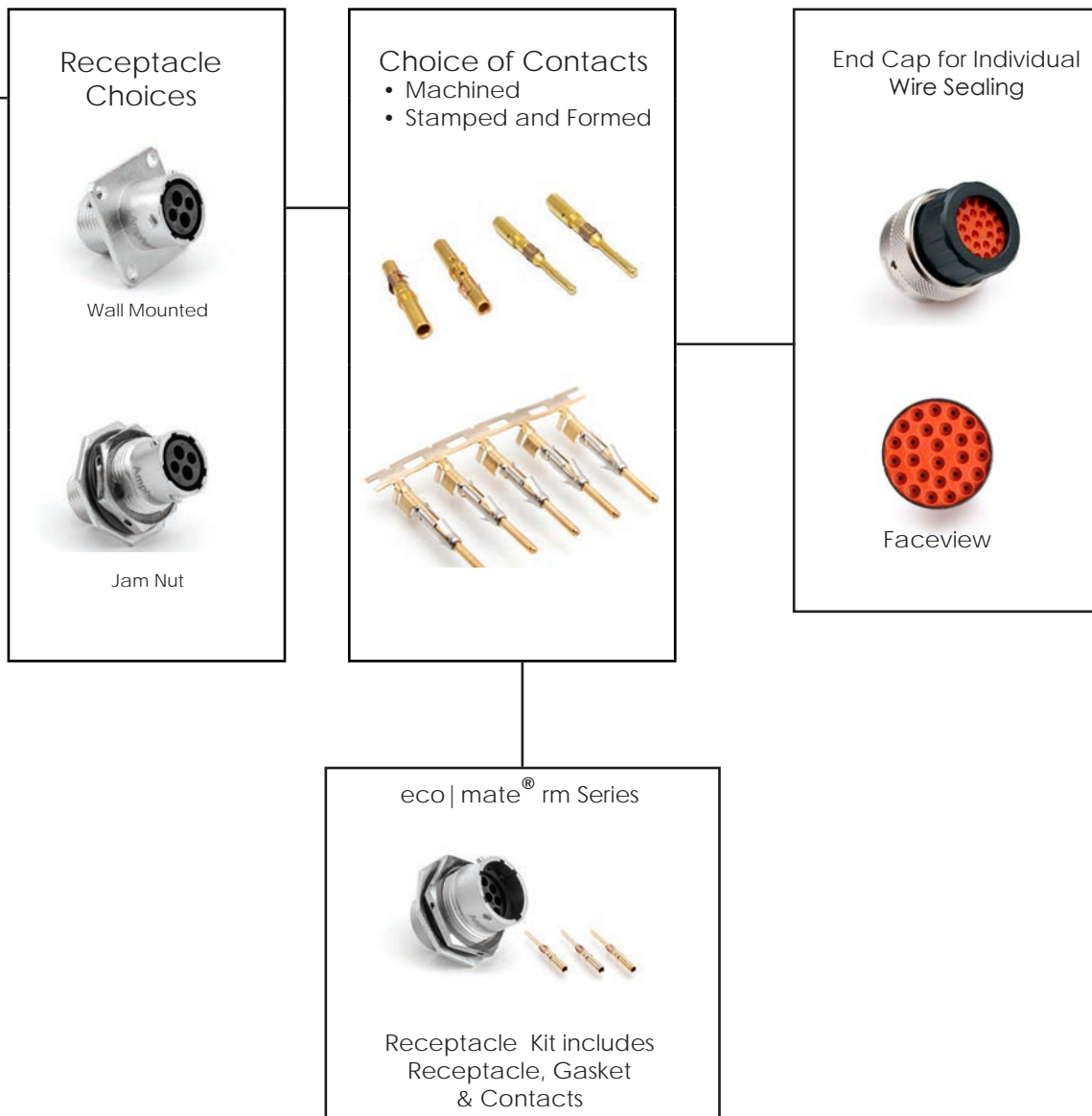





Connector Solutions:
see page 19 for parts grouped by insert arrangement



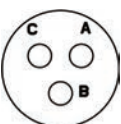

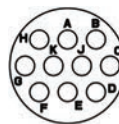
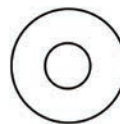
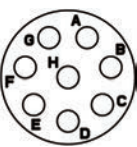
eco|mate[®] rm

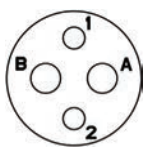
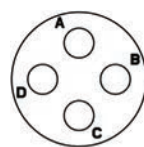
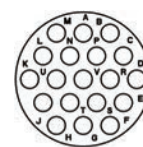
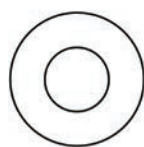
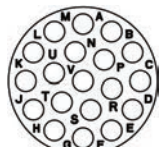
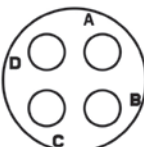
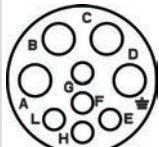
Rugged Metal Shielded Connectors

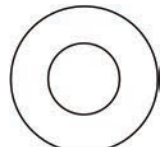
Insert Arrangements

Shell Size	RT0				RTHP		
	Contact #16 (Ø 1.6)	Mixed Power & Signal	Contact 2.5mm	Contact #20 (Ø 1.0)	Single Pin Power RADSOK [®]		
10	 <p>4 positions Contact #16 (Ø 1.6) 13A 300V see page 29</p>	 <p>4 positions Contact #16 (Ø 1.6) & #20 (Ø 1.0) 13A & 20# 5A 350V AC/DC see page 37</p>	Consult factory	 <p>6 positions Contact #20 (Ø 1.0) 5A, 7A(machined) 150V see page 71</p>	Consult factory		
12	 <p>3 positions Contact #16 (Ø 1.6) 13A 300V see page 21</p>	 <p>8 positions Contact #16 (Ø 1.6) 13A 300V see page 79</p>	Consult factory	 <p>10 positions Contact #20 (Ø 1.0) 5A, 7.5A(machined) 150V see page 111</p>	 <p>1 position Contact 3.6mm 86A 630V AC/DC see page 179</p>		
14	 <p>8 positions Contact #16 (Ø 1.6) 13A 300V AC/DC page 87</p>	 <p>12 positions Contact #16 (Ø 1.6) 13A 300V see page 119</p>	 <p>4 positions Contact 2.5mm #16 (Ø 1.6) 23A & 13A 350V AC/DC see page 47</p>	Consult factory	 <p>4 positions Contact 2.5mm 23A 350V AC/DC see page 55</p>	 <p>19 positions Contact #20 (Ø 1.0) 5A, 7.5A(machined) 150V see page 127</p>	 <p>1 position Contact 6mm 120A 630V AC/DC see page 183</p>
16	 <p>19 positions Contact #16 (Ø 1.6) 13A 300V see page 135</p>	 <p>4 positions Contact #8 (Ø 3.6) 45A 500V AC/DC see page 63</p>	 <p>9 positions Contact 2.5mm & #16 (Ø 1.6) 23A & 13A 350V AC/DC see page 103</p>	Consult factory	 <p>26 positions Contact #20 (Ø 1.0) 5A, 7.5A(machined) 150V see page 151</p>	 <p>1 position Contact 8mm 120A - 180A 630V AC/DC see page 187</p>	

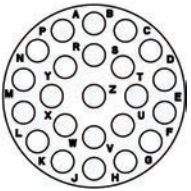
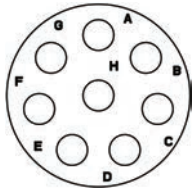
Connector Guide

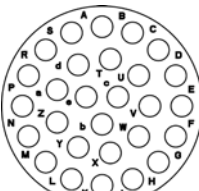
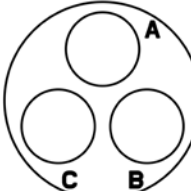
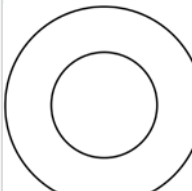
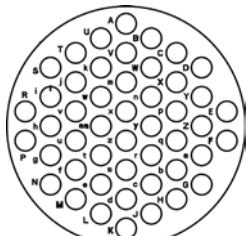
Shell Size	RTO			RTHP	
	Contact #16 (Ø 1.6)	Mixed Power & Signal	Contact 2.5mm	Contact #20 (Ø 1.0) or Contact 3.6mm	Single Pin Power RADSOK®
18	 <p>23 positions Contact #16 (Ø 1.6) 13A 300V see page 143</p>	Consult factory	 <p>8 positions Contact 2.5mm 23A 375V AC/DC see page 95</p>	 <p>32 positions Contact #20 (Ø 1.0) 5A, 7.5A 150V see page 167</p>	Consult factory
20	 <p>28 positions Contact #16 (Ø 1.6) 13A 300V see page 159</p>	Consult factory	Consult factory	RTHP	
				 <p>3 positions Contact 3.6mm 86A 630V see page 197</p>	 <p>1 position Contact 10mm 120A - 300A 630V see page 191</p>
24	 <p>48 positions Contact #16 (Ø 1.6) 13A 300V see page 177</p>	Consult factory	Consult factory	Consult factory	Consult factory

Insert Arrangements are Pin Faceview

eco|mate[®] rm

Rugged Metal Shielded Connectors

General Technical Characteristics



Materials

- **Zinc Alloy Shells**
- **Metal Alloy Backshells and Cable Glands**
- **Aluminum Alloy, Nickel Plated Coupling Ring**
- **Stainless Steel Coupling Spring**
- **Contacts Plating Options**
 - Gold Flash over Tin
 - Tin
 - Silver
 - 5μ, 10μ, 15μ, 30μ
 - Gold Flash
 - Other platings on request
- **Insulation Resistance**
 - 5000 megohms minimum of 25° C
- **Insulation Inserts**
 - Thermoplastic, UL94 V-0

Environmental

- **IP67**
- **Operating Temperature**
 - 40° to 105° C - Standard Products with NBR Seal
 - 40° to 125° C - Standard Products with Silicone Seal
 - 40° to 125° C - High Amperage Products with RADSOK[®] technology
- **Flammability Rating** UL94 V-0
- **Salt Spray**
 - Per MIL-STD-202 method 101
 - 48 h (standard version)
 - 96 h (black anodized coupling ring)
 - Higher salt spray resistance (200/500h) upon request
- **Sealing**
 - In mated condition and in combination with sealed backshell
- **Fluid Resistance**
 - Gas, oil, mineral oil, acid bath, basic bath

Connector Guide



Electrical

- **In Accordance With**
UL 1977: Certificate ECBT2
File number: E339831
- **More information**
see "Technical Section" starting on
page 228

Mechanical

- **Durability**
RT Series : >500 mating cycles
RTHP Series: >100 mating cycles
- **Vibration**
10-2000 Hz, level of 20 G's
- **Thermal Shock**
No cracking, chipping or leaking after 20
test cycles from -55°C to 125°C
- **Contact Resistance**
#16 <6 mΩ
#20 <15 mΩ
eco|mate® rm with RADSOK® < 1m Ω

Connector Guide

GuardSafe™ Locking Clips

Amphenol's **GuardSafe™ Locking Clips** are designed to complement the **eco|mate® rm** multi-way connector and **Amphenol PT\26482 Series** cylindrical metal bayonet coupling systems, and are suitable for many rough, harsh environmental applications. Featuring non-corrosive, plastic construction with clamshell functionality, they are resistant to brake and transmission fluid, oils, grease, salt, dirt and other contaminants. Compliant with new FM standards, the GuardSafe™ Locking Clip offers an extra layer of protection from an inadvertent uncoupling of the connector.



Cost Effective Safety Protection

GuardSafe™ Locking Clips render quick disconnections not “normally arching” by eliminating access to the coupling nut and requiring a tool for removal.

Easy to Use

User-friendly, easy to install and service.

Suitability

GuardSafe™ Locking Clips are suitable to be used with wiring methods in accordance with Class I, Division 2 wiring practices per the National Electric Code (NEC), ANSI\NFPA 70, Article 501.4(B).

Installation:

Locate the clip over the connector coupling nut with the lanyard towards the plug adapter as shown. Close the safety clip.

Removal:

Locate a screwdriver on first latch as shown. Push down the latch then twist the screwdriver. Repeat actions for second latch.



Locking Clips are also Compatible with **Amphenol PT\26482 Series** Cylindrical Metal Bayonet Coupling Systems!

Go to www.amphenol-sine.com for more information about the PT Series

eco mate® rm	
Shell Size	Part #
10	108039110
12	108039112
14	108039114
16	108039116
18	108039118
20	108039120
22	108039122
24	108039124

Connector Guide

Connector Kits

Q: Why are we offering "kits"?

A: Making "kits" available to our customers allows for reducing the number of part numbers necessary for any given project, whether for in-house production or field serviceable applications.

Amphenol's **eco|mate® rm Rugged Metal Shielded Connector Kits** offer mated multi-way connector parts available in 6 shell sizes and 12 insert arrangements, with a variety of wire gauge options. **eco|mate® rm** industrial circular connectors are designed to be intermateable with other industry standard connectors. All connectors are RoHS compliant.

Market Applications:

- Instrumentation Measurement
- Robotics
- Machine Tools
- Building Automation & Control
- Telecom - Data Infrastructure
- Welding
- Medical
- Aerospace
- Energy Power
- Military
- Automotive
- Off Road
- Mining
- Railway
- Electric Vehicles



Plug Kit

Including Connector, Backshell & Contacts



Square Flange Receptacle Kit

Including Receptacle, Gasket & Contacts



Jam Nut Receptacle Kit

Including Receptacle & Contacts

eco|mate® rm Kits

- 6 shell sizes/12 insert configurations
- Insert arrangements from 4-32 contacts
- Operating voltage of 150V or 300V
- Current rating: 5A, 7.5A(machined) or 13A (signal contacts)
- Alternate keying positions available
- Plastic inserts with flammability rating of UL94-V0



eco|mate[®] rm

Rugged Metal Shielded Connectors

Connector Solutions

eco|mate[®] rm Standard Products

3 POSITIONS 13A / 300V	21
4 POSITIONS 13A / 300V	29
4 POSITIONS MIX 13A & 5A / 350V	37
4 POSITIONS MIX 23A & 13A / 350V	47
4 POSITIONS 23A / 350V	55
4 POSITIONS 45A / 500V	63
6 POSITIONS 5A / 150V	71
8 POSITIONS 13A / 250V	79
8 POSITIONS 13A / 300V	87
8 POSITIONS 23A / 375V	95
9 POSITIONS MIX 23A & 13A / 250V	103
10 POSITIONS 5A, 7.5A / 150V	111
12 POSITIONS 13A / 300V	119
19 POSITIONS 5A, 7.5A / 150V	127
19 POSITIONS 13A / 300V	135
23 POSITIONS 13A / 300V	143
26 POSITIONS 5A, 7.5A / 150V	151
28 POSITIONS 13A / 300V	159
32 POSITIONS 5A, 7.5A / 150V	167
48 POSITIONS 13A / 300V	175

High Amperage eco|mate[®] rm with RADSOK[®] Technology

1 POSITION 86A / 630V	179
1 POSITION 120A / 630V	183
1 POSITION 120A - 180A / 630V	187
1 POSITION 120A - 300A / 630V	191
3 POSITIONS 86A / 630V	197

STEP 1
Choose Receptacle Style

STEP 2
Choose Plug Style

STEP 2
Choose Backshell Style

Jam Nut Receptacles



OR
Square Flange Receptacles



Jam Nut Receptacle Kit Including Receptacle & Contacts



Square Flange Receptacle Kit Including Receptacle, Gasket & Contacts



Plug



Backshell



OR
Plug Kit Including Connector, Backshell & Contacts



SEE TABLE ON NEXT PAGE FOR PART DETAILS

CONTACTS SOLD SEPARATELY SEE PAGE 26

Shell Size: 12 Number of Contacts: 3 Contact Size: 16
Sealing: IP67 Salt Spray: 48h

eco | mate[®] rm Standard Products

- Suitable For Indoor and Outdoor Applications
- EMI/RMI Shielding Capability with Appropriate Backshell
- Operating Temperature: -40°C to +105°C
- 500 Mating Cycles
- Contacts and Cord Grips Ordered Separately
- UL ECBT2 Certified*

An upgraded silicone seal is available for all connector parts. Please add "03" to the end of the part number when ordering. Operating Temperature: -40°C to +125°C. Not available in kits.

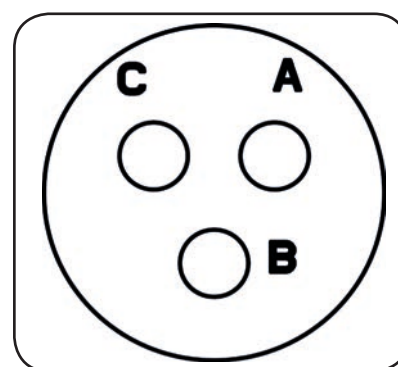

Insert Arrangement
Pin (Male) Faceview

Connector Part Numbers

Part Number		Connector Type	Figure Drawings	
Male	Female		Male	Female
RT07123PNH	RT07123SNH	Jam Nut Receptacle	1,5	2,5
RT07123PNHEC	RT07123SNHEC	Jam Nut Receptacle with O-ring Seal and End Cap with Individual Rear Wire Seal**	3,5	4,5
RT07123PNHK	RT07123SNHK	Jam Nut Receptacle Kit	1,5	2,5
RT06123PNH	RT06123SNH	Plug	6	7
RT06123PNHEC	RT06123SNHEC	Plug with O-ring Seal and End Cap with Individual Rear Wire Seal**	8	9
RT06123PNHK	RT06123SNHK	Plug Kit	6	7
RT00123PNH	RT00123SNH	Square Flange Receptacle	10,14	11,14
RT00123PNHEC	RT00123SNHEC	Square Flange Receptacle with O-ring Seal and End Cap with Individual Rear Wire Seal**	12,14	13,14
RT00123PNHK	RT00123SNHK	Square Flange Receptacle Kit	10,14	11,14

Contacts supplied separately see page 26

**See page 23 for the real seal wire range

Backshells

Part Number	Backshell Type	Cable Range (mm)	Figure Drawings	Shielding
RT0S12CGNS1	Short Cord Grip (straight)	6-10.5	15	✓
RT0S12CGNS2	Short Cord Grip (straight)	8.5-12.5	15	✓
RT0L12CGNS1	Long Cord Grip (straight)	6-10.5	16	✓
RT0L12CGNS2	Long Cord Grip (straight)	8.5-12.5	16	✓
RT0B12CGNS1	Cord Grip (90°)	6-10.5	17	✓
RT0B12CGNS2	Cord Grip (90°)	8.0-12.5	17	✓

*Connector parts with part numbers ending in EC (with an end cap) were not available for submittal at the time of UL certification.

Shell Size: 12 Number of Contacts: 3
 Sealing: IP67 Salt Spray: 48h

Contact Size: 16

Dimensions Jam Nut Receptacle

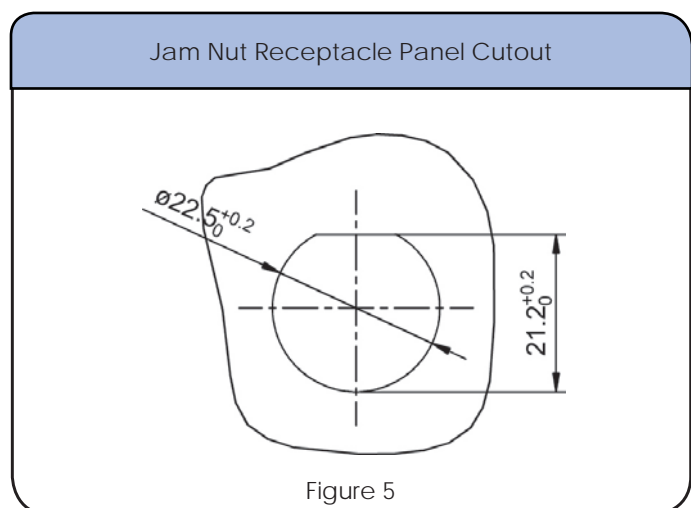
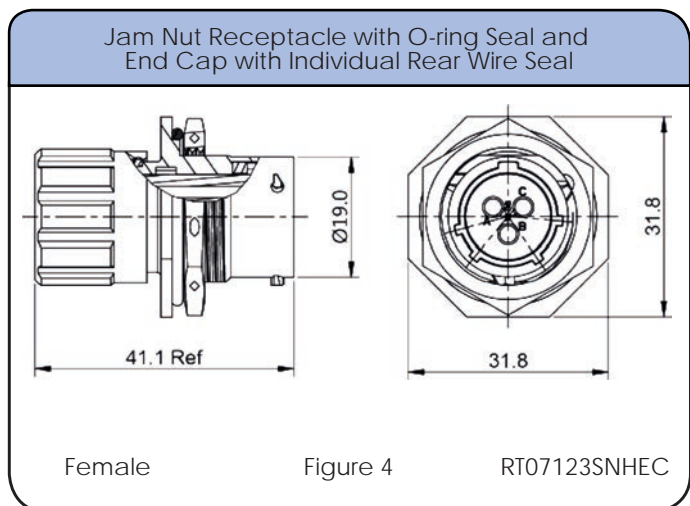
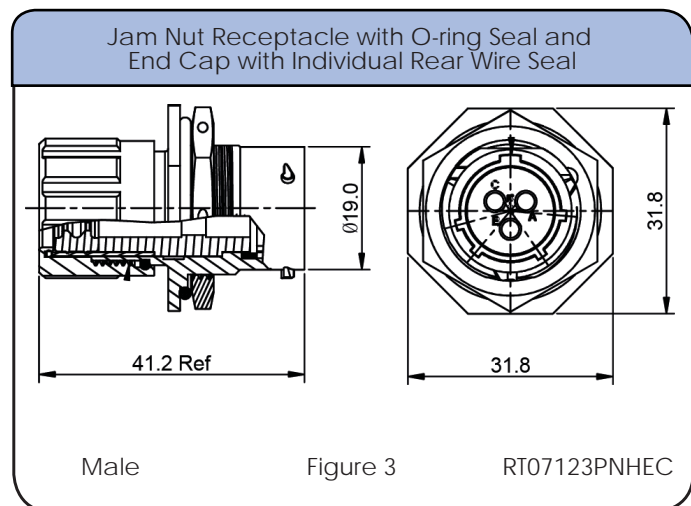
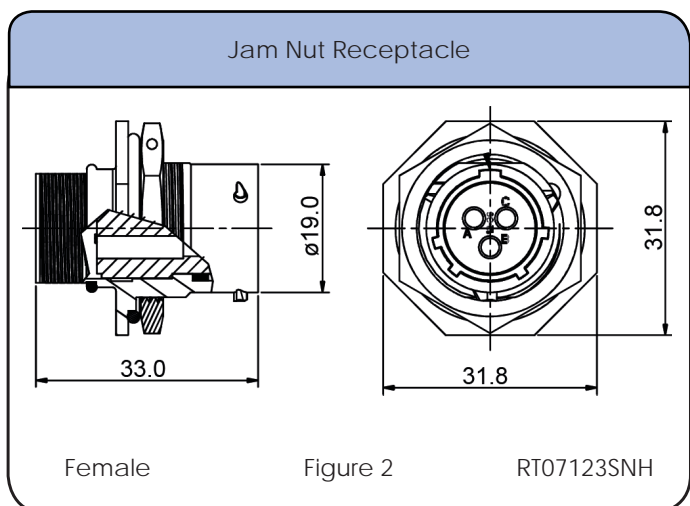
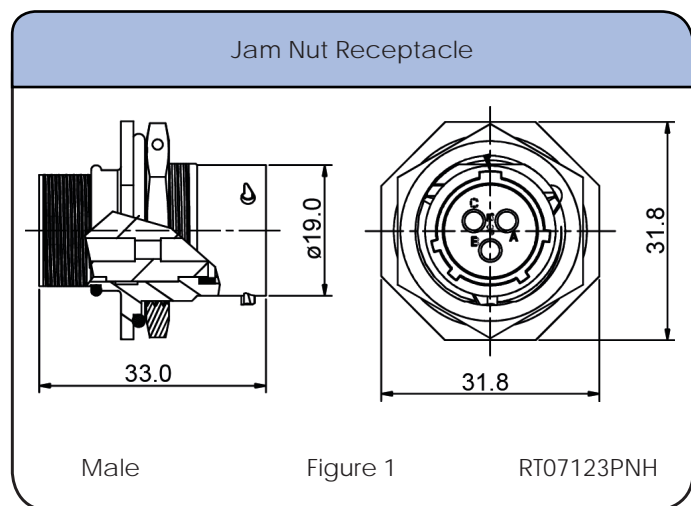

Shell Size: 12 Number of Contacts: 3 Contact Size: 16
Sealing: IP67 Salt Spray: 48h

Dimensions Plug

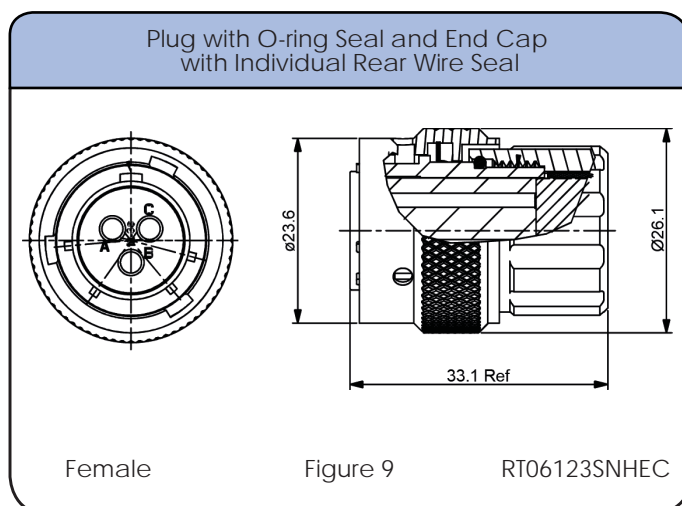
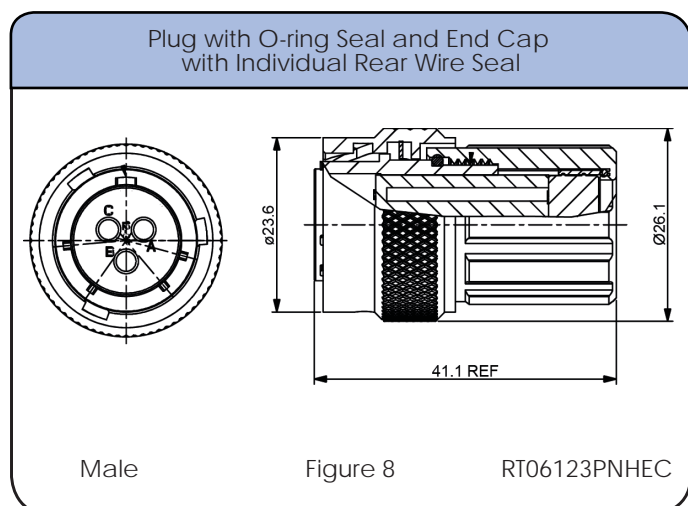
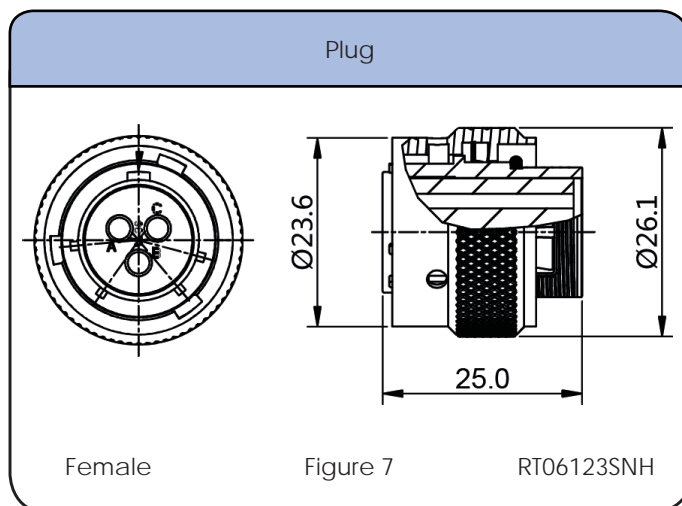
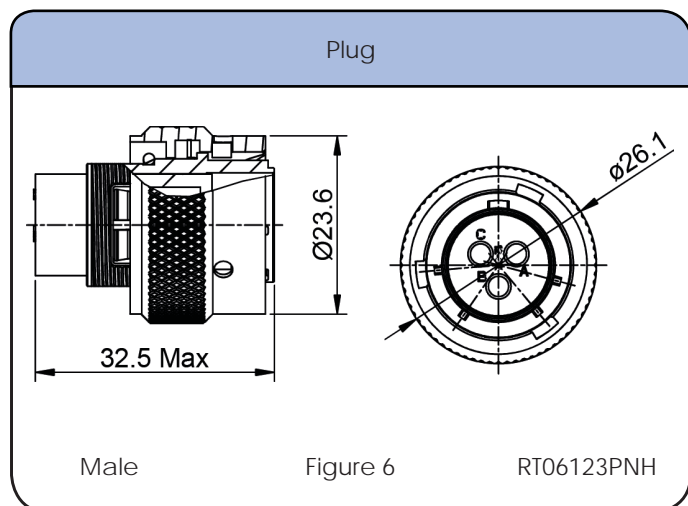

Individual Sealing Wire Range

Contact Size	Insulation Overall Diameter (min-max)	Wire Range
16	Ø2.0mm - Ø3.2mm	14 - 24 AWG

Shell Size: 12 Number of Contacts: 3 Contact Size: 16
 Sealing: IP67 Salt Spray: 48h

Dimensions Square Flange Receptacle

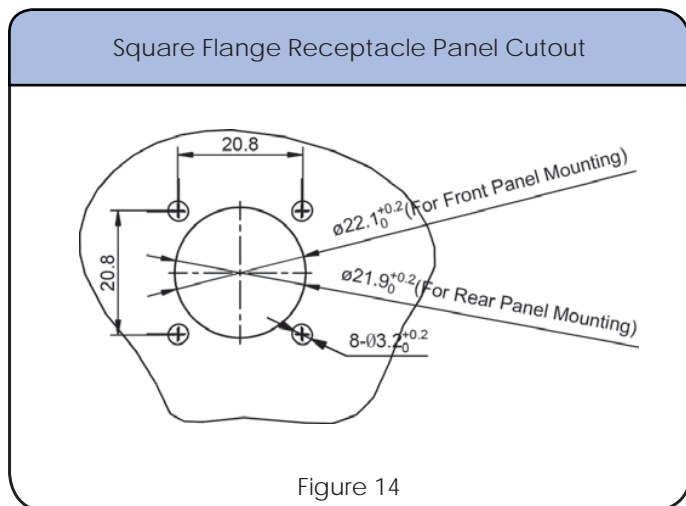
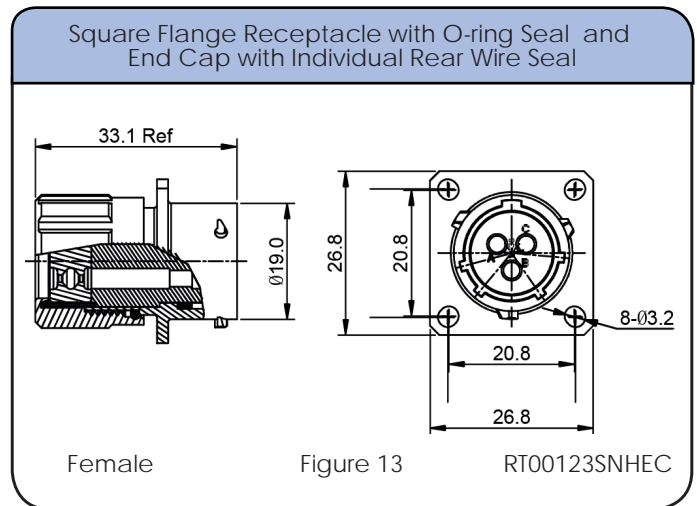
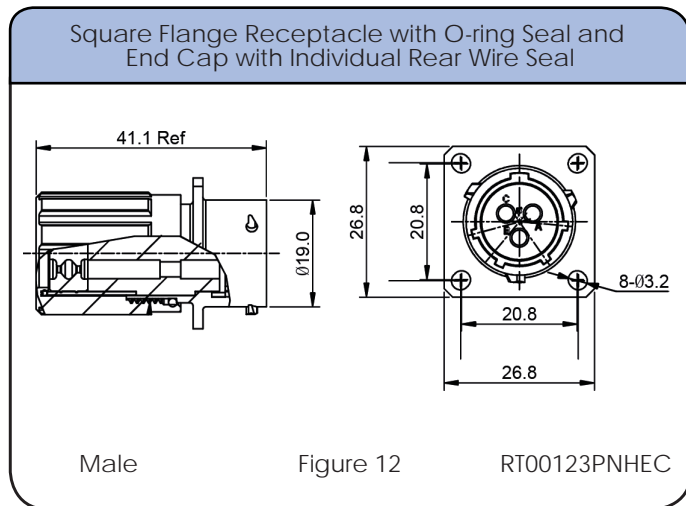
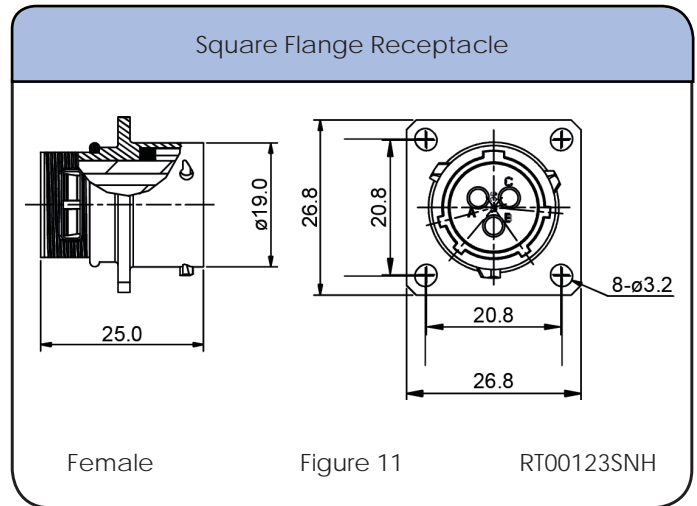
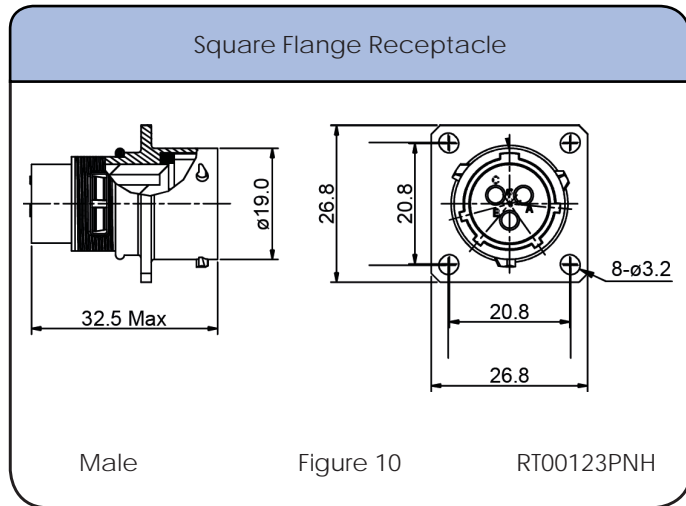

Shell Size: 12 Number of Contacts: 3 Contact Size: 16
Sealing: IP67 Salt Spray: 48h

Dimensions Backshell

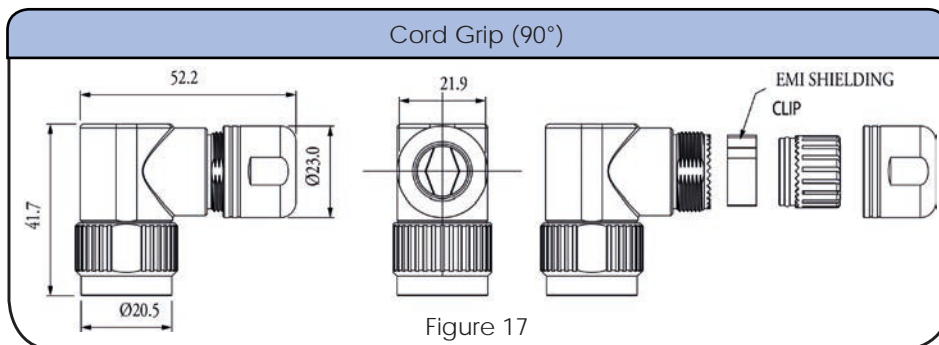
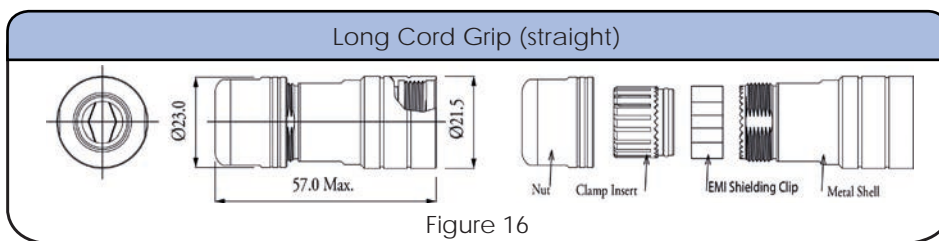
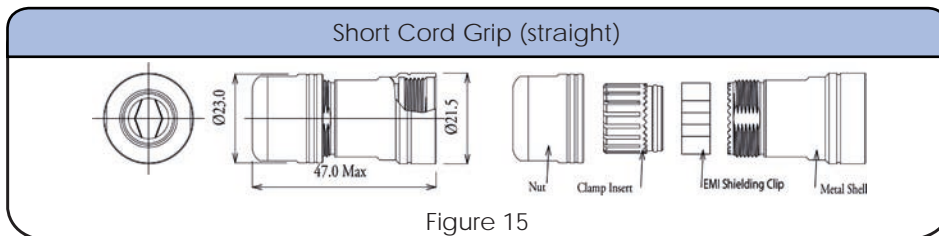

Accessories

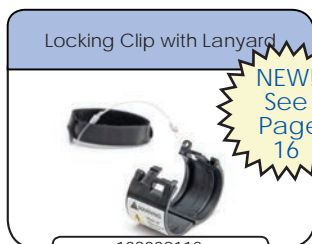

NEW!
See
Page
16

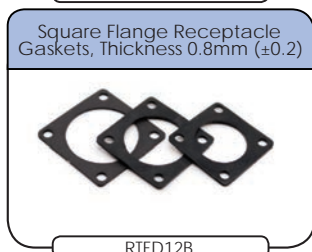
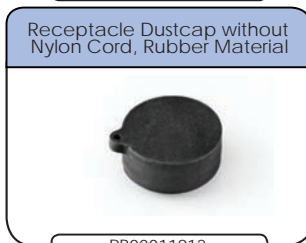
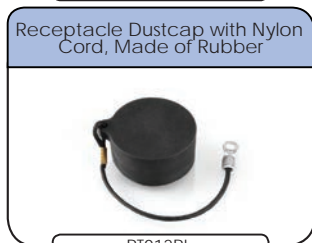
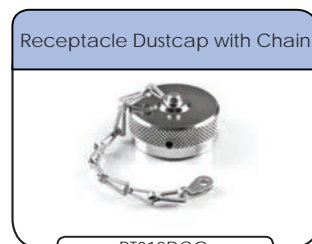

Shell Size: 12
Sealing: IP67

Number of Contacts: 3
Salt Spray: 48h

Contact Size: 16

Contacts



Crimp Contacts, Machined

Part Number		AWG	Wire Range (mm ²)	Plating
Male	Female			
MP14M23F	MS14M23F	14	2.0-2.5	Gold Flash
MP14M23G5	MS14M23G5	14	2.0-2.5	Gold 5μ"
MP14M23G10	MS14M23G10	14	2.0-2.5	Gold 10μ"
MP14M23G15	MS14M23G15	14	2.0-2.5	Gold 15μ"
MP14M23G30	MS14M23G30	14	2.0-2.5	Gold 30μ"
MP16M23F	MS16M23F	18-16	.75-1.5	Gold Flash
MP16M23G5	MS16M23G5	18-16	.75-1.5	Gold 5μ"
MP16M23G10	MS16M23G10	18-16	.75-1.5	Gold 10μ"
MP16M23G15	MS16M23G15	18-16	.75-1.5	Gold 15μ"
MP16M23G30	MS16M23G30	18-16	.75-1.5	Gold 30μ"
MP20M23F	MS20M23F	22-20	.34-.50	Gold Flash
MP20M23G5	MS20M23G5	22-20	.34-.50	Gold 5μ"
MP20M23G10	MS20M23G10	22-20	.34-.50	Gold 10μ"
MP20M23G15	MS20M23G15	22-20	.34-.50	Gold 15μ"
MP20M23G30	MS20M23G30	22-20	.34-.50	Gold 30μ"
MP24M23F	MS24M23F	26-24	.14-.25	Gold Flash
MP24M23G5	MS24M23G5	26-24	.14-.25	Gold 5μ"
MP24M23G10	MS24M23G10	26-24	.14-.25	Gold 10μ"
MP24M23G15	MS24M23G15	26-24	.14-.25	Gold 15μ"
MP24M23G30	MS24M23G30	26-24	.14-.25	Gold 30μ"

Tools



Shell Size: 12 Number of Contacts: 3 Contact Size: 16
Sealing: IP67 Salt Spray: 48h

Contacts (con't)



Stamped & Formed Contacts

Crimp Contacts, Stamped & Formed

Part Number		AWG	Wire Range (mm ²)	Plating
Male	Female			
SP14M1F	SS14M1F	14	2.0-2.5	Gold Flash
SP14M1G5	SS14M1G5	14	2.0-2.5	Gold 5μ"
SP14M1G10	SS14M1G10	14	2.0-2.5	Gold 10μ"
SP14M1G15	SS14M1G15	14	2.0-2.5	Gold 15μ"
SP14M1G30	SS14M1G30	14	2.0-2.5	Gold 30μ"
SP16M1F	SS16M1F	18-16	.75-1.5	Gold Flash
SP16M1G5	SS16M1G5	18-16	.75-1.5	Gold 5μ"
SP16M1G10	SS16M1G10	18-16	.75-1.5	Gold 10μ"
SP16M1G15	SS16M1G15	18-16	.75-1.5	Gold 15μ"
SP16M1G30	SS16M1G30	18-16	.75-1.5	Gold 30μ"
SP20M1F	SS20M1F	22-20	.34-.50	Gold Flash
SP20M1G5	SS20M1G5	22-20	.34-.50	Gold 5μ"
SP20M1G10	SS20M1G10	22-20	.34-.50	Gold 10μ"
SP20M1G15	SS20M1G15	22-20	.34-.50	Gold 15μ"
SP20M1G30	SS20M1G30	22-20	.34-.50	Gold 30μ"
SP24M1F	SS24M1F	22-20	.14-.25	Gold Flash
SP24M1G5	SS24M1G5	26-24	.14-.25	Gold 5μ"
SP24M1G10	SS24M1G10	26-24	.14-.25	Gold 10μ"
SP24M1G15	SS24M1G15	26-24	.14-.25	Gold 15μ"
SP24M1G30	SS24M1G30	26-24	.14-.25	Gold 30μ"

Tools



QXRT16



MFX-3954



MFX-3957

STEP 1
Choose Receptacle Style

STEP 2
Choose Plug Style

STEP 2
Choose Backshell Style

Jam Nut Receptacles



OR
Square Flange Receptacles



Jam Nut Receptacle Kit Including Receptacle & Contacts



Square Flange Receptacle Kit Including Receptacle, Gasket & Contacts



Plug



Backshell



OR
Plug Kit Including Connector, Backshell & Contacts



SEE TABLE ON NEXT PAGE FOR PART DETAILS

CONTACTS SOLD SEPARATELY SEE PAGE 34

Shell Size: 10 Number of Contacts: 4 Contact Size: 16
Sealing: IP67 Salt Spray: 48h

eco | mate[®] rm
Standard Products

- Suitable For Indoor and Outdoor Applications
- EMI/RMI Shielding Capability with Appropriate Backshell
- Operating Temperature: -40°C to +105°C
- 500 Mating Cycles
- Contacts and Cord Grips Ordered Separately
- UL ECBT2 Certified*

An upgraded silicone seal is available for all connector parts. Please add "03" to the end of the part number when ordering. Operating Temperature: -40°C to +125°C. Not available in kits.

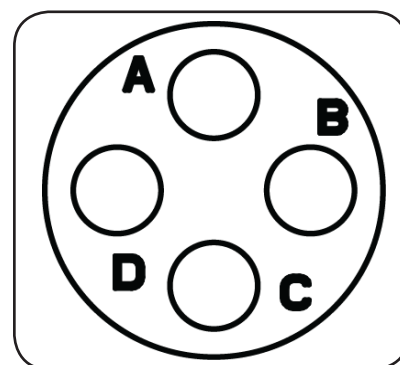

Insert Arrangement
Pin (Male) Faceview

Connector Part Numbers

Part Number		Connector Type	Figure Drawings	
Male	Female		Male	Female
RT07104PNH	RT07104SNH	Jam Nut Receptacle	1,5	2,5
RT07104PNHEC	RT07104SNHEC	Jam Nut Receptacle with O-ring Seal and End Cap with Individual Rear Wire Seal**	3,5	4,5
RT07104PNHK	RT07104SNHK	Jam Nut Receptacle Kit	1,5	2,5
RT06104PNH	RT06104SNH	Plug	6	7
RT06104PNHEC	RT06104SNHEC	Plug with O-ring Seal and End Cap with Individual Rear Wire Seal**	8	9
RT06104PNHK	RT06104SNHK	Plug Kit	6	7
RT00104PNH	RT00104SNH	Square Flange Receptacle	10,14	11,14
RT00104PNHEC	RT00104SNHEC	Square Flange Receptacle with O-ring Seal and End Cap with Individual Rear Wire Seal**	12,14	13,14
RT00104PNHK	RT00104SNHK	Square Flange Receptacle Kit	10,14	11,14

Contacts supplied separately see page 34

**See page 31 for the real seal wire range

Backshells

Part Number	Backshell Type	Cable Range (mm)	Figure Drawings	Shielding
RT0S10CGNS1	Short Cord Grip (straight)	3-6.5	15	✓
RT0S10CGNS2	Short Cord Grip (straight)	5-8.5	15	✓
RT0L10CGNS1	Long Cord Grip (straight)	3-6.5	16	✓
RT0L10CGNS2	Long Cord Grip (straight)	5-8.5	16	✓

*Connector parts with part numbers ending in EC (with an end cap) were not available for submittal at the time of UL certification.

Shell Size: 10 Number of Contacts: 4
 Sealing: IP67 Salt Spray: 48h

Contact Size: 16

Dimensions Jam Nut Receptacle

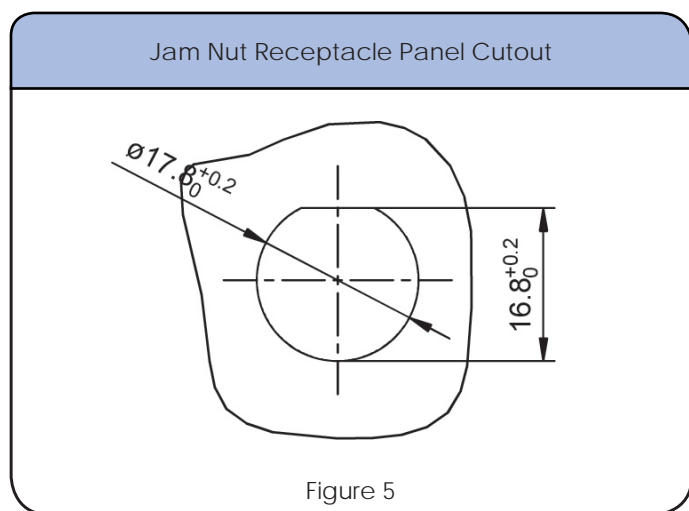
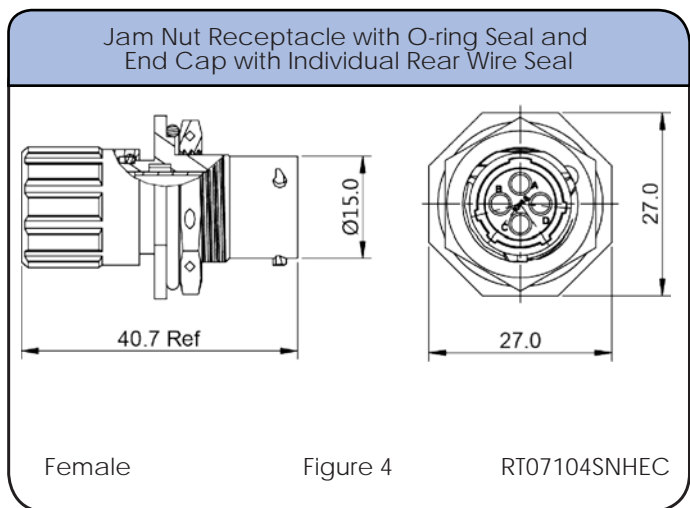
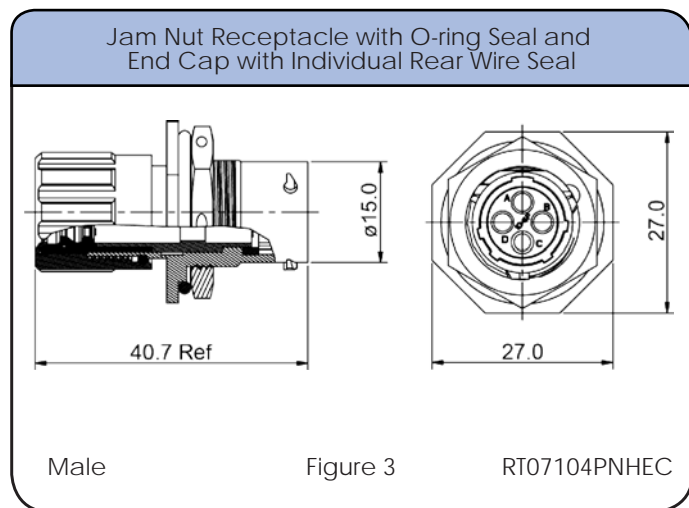
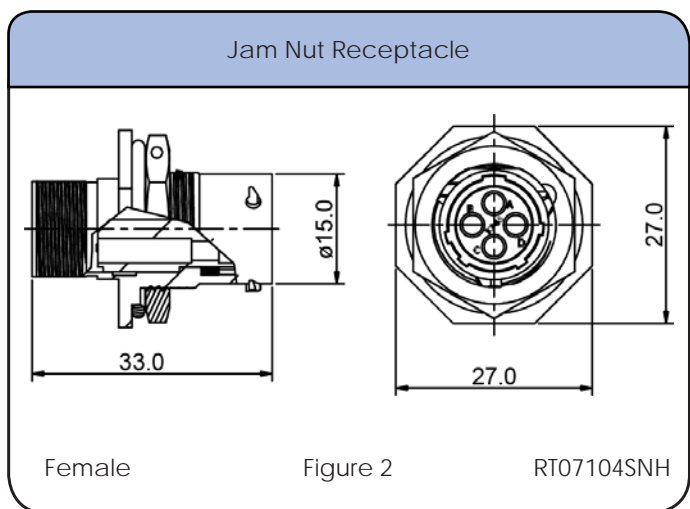
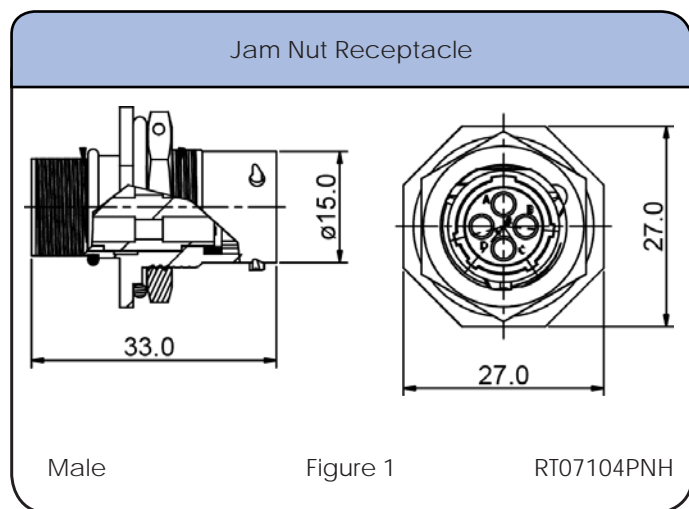

Shell Size: 10 Number of Contacts: 4 Contact Size: 16
Sealing: IP67 Salt Spray: 48h

Dimensions Plug

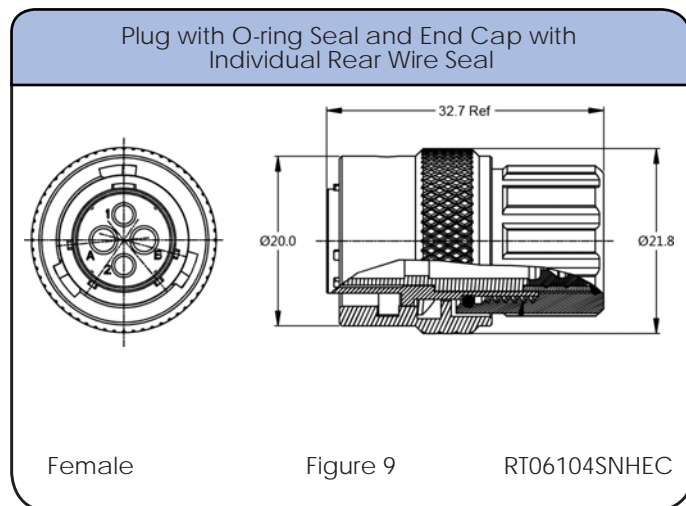
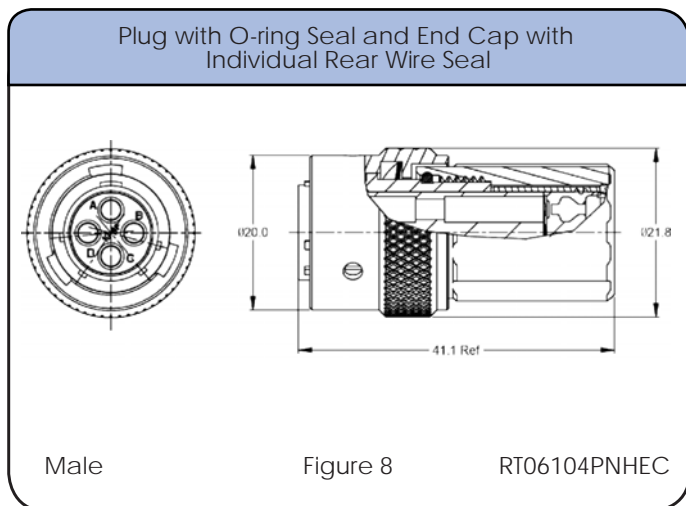
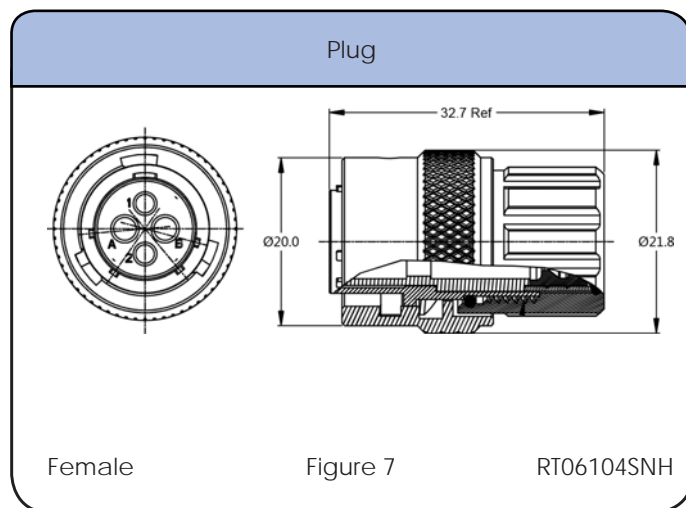
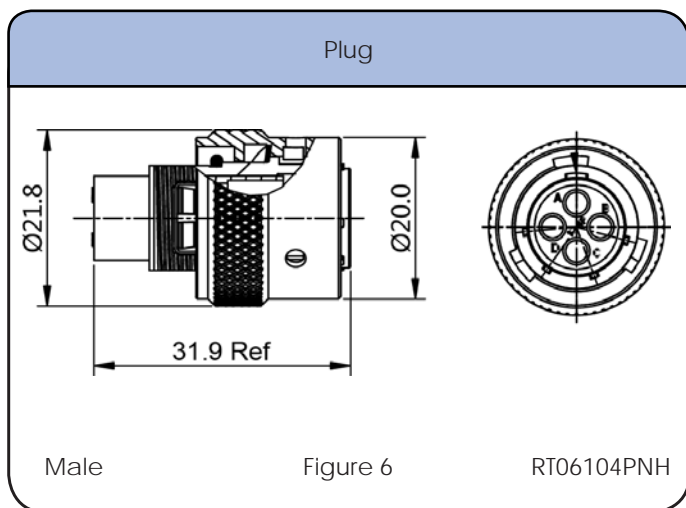

Individual Sealing Wire Range

Contact Size	Insulation Overall Diameter (min-max)	Wire Range
16	Ø2.0mm - Ø3.2mm	14 - 24 AWG

Shell Size: 10 Number of Contacts: 4 Contact Size: 16
 Sealing: IP67 Salt Spray: 48h

Dimensions Square Flange Receptacle

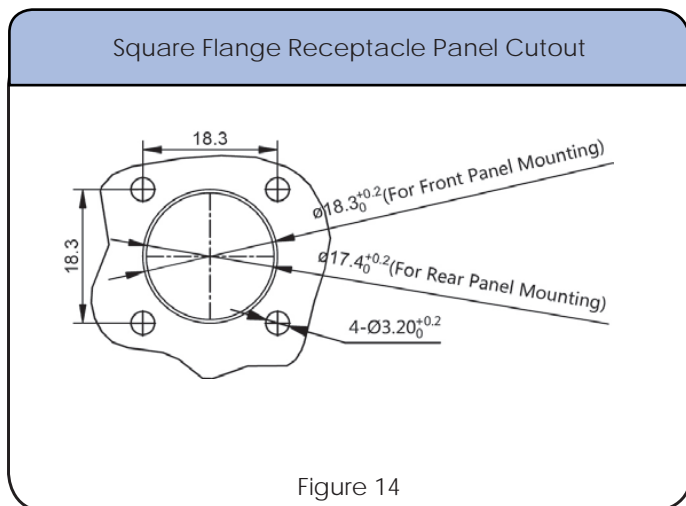
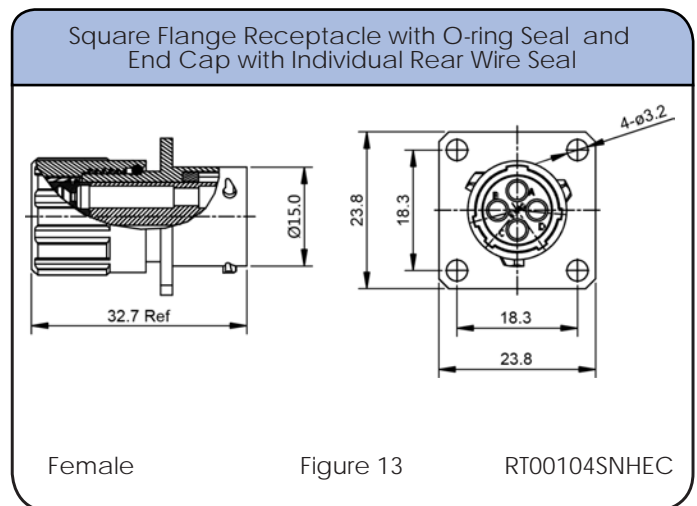
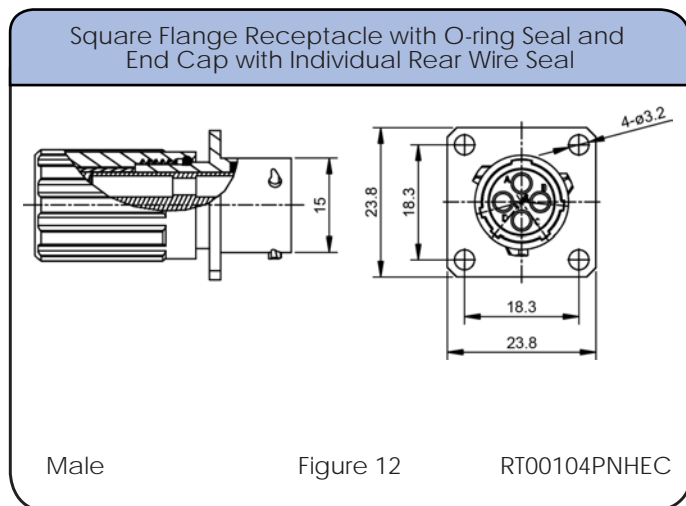
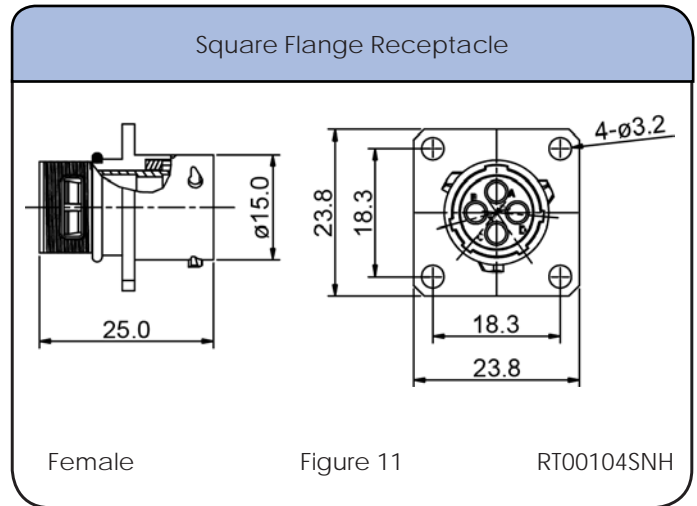
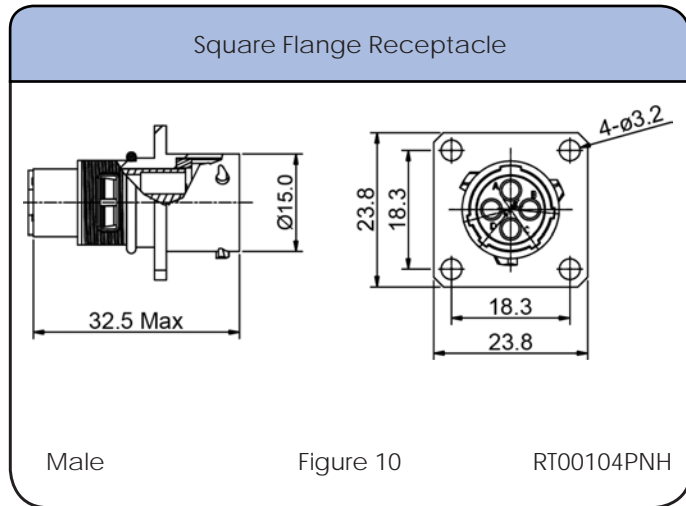

Shell Size: 10 Number of Contacts: 4 Contact Size: 16
Sealing: IP67 Salt Spray: 48h

Dimensions Backshell

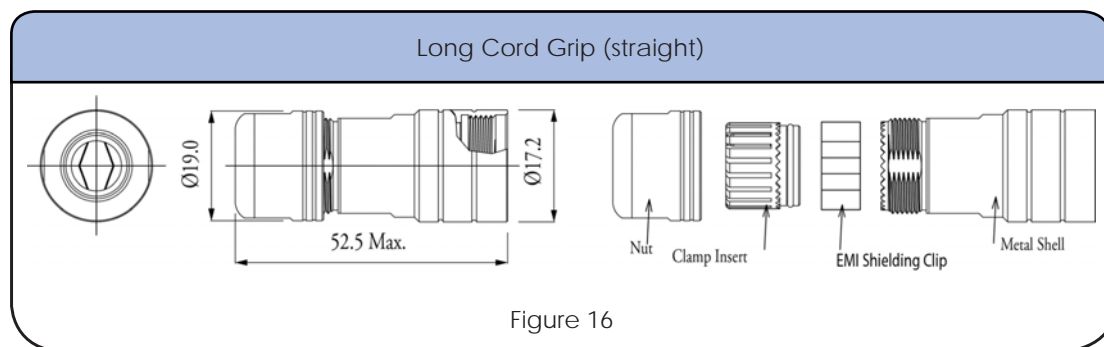
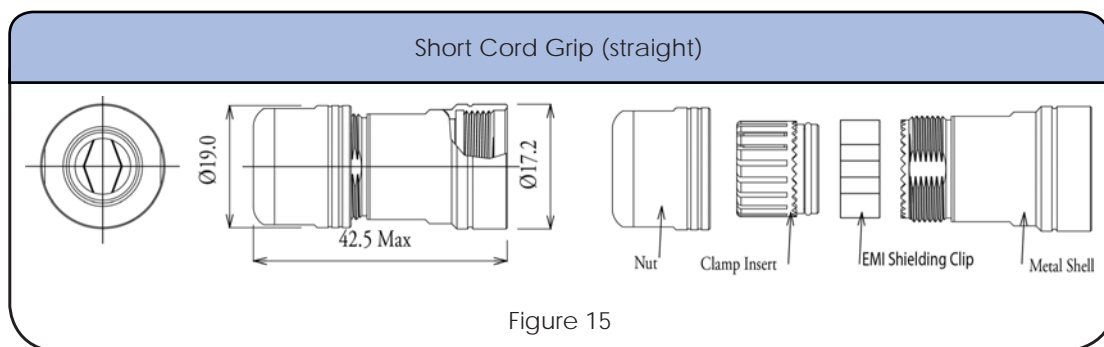

Accessories

<p>Locking Clip with Lanyard</p> <p>108039110</p>	<p>Plug Dustcap with Chain</p> <p>RT610DCG</p>	<p>Plug Dustcap without Chain</p> <p>RT610DC</p>	<p>Receptacle Dustcap without Chain</p> <p>RT010DC</p>
<p>Receptacle Dustcap with Chain</p> <p>RT010DCG</p>	<p>Receptacle Dustcap without Nylon Cord, Rubber Material</p> <p>RB00011910</p>	<p>Receptacle Dustcap with Nylon Cord, Made of Rubber</p> <p>RT010RL</p>	<p>Sealing Plug</p> <p>CA401659</p>
<p>Square Flange Receptacle Gaskets, Thickness 0.8mm (±0.2)</p> <p>RTFD10B</p>			

NEW!
See Page 16

Shell Size: 10
Sealing: IP67

Number of Contacts: 4
Salt Spray: 48h

Contact Size: 16

Contacts



Crimp Contacts, Machined

Part Number		AWG	Wire Range (mm ²)	Plating
Male	Female			
MP14M23F	MS14M23F	14	2.0-2.5	Gold Flash
MP14M23G5	MS14M23G5	14	2.0-2.5	Gold 5μ"
MP14M23G10	MS14M23G10	14	2.0-2.5	Gold 10μ"
MP14M23G15	MS14M23G15	14	2.0-2.5	Gold 15μ"
MP14M23G30	MS14M23G30	14	2.0-2.5	Gold 30μ"
MP16M23F	MS16M23F	18-16	.75-1.5	Gold Flash
MP16M23G5	MS16M23G5	18-16	.75-1.5	Gold 5μ"
MP16M23G10	MS16M23G10	18-16	.75-1.5	Gold 10μ"
MP16M23G15	MS16M23G15	18-16	.75-1.5	Gold 15μ"
MP16M23G30	MS16M23G30	18-16	.75-1.5	Gold 30μ"
MP20M23F	MS20M23F	22-20	.34-.50	Gold Flash
MP20M23G5	MS20M23G5	22-20	.34-.50	Gold 5μ"
MP20M23G10	MS20M23G10	22-20	.34-.50	Gold 10μ"
MP20M23G15	MS20M23G15	22-20	.34-.50	Gold 15μ"
MP20M23G30	MS20M23G30	22-20	.34-.50	Gold 30μ"
MP24M23F	MS24M23F	26-24	.14-.25	Gold Flash
MP24M23G5	MS24M23G5	26-24	.14-.25	Gold 5μ"
MP24M23G10	MS24M23G10	26-24	.14-.25	Gold 10μ"
MP24M23G15	MS24M23G15	26-24	.14-.25	Gold 15μ"
MP24M23G30	MS24M23G30	26-24	.14-.25	Gold 30μ"

Tools



Shell Size: 10 Number of Contacts: 4 Contact Size: 16
Sealing: IP67 Salt Spray: 48h

Contacts (con't)



Crimp Contacts, Stamped & Formed

Part Number		AWG	Wire Range (mm ²)	Plating
Male	Female			
SP14M1F	SS14M1F	14	2.0-2.5	Gold Flash
SP14M1G5	SS14M1G5	14	2.0-2.5	Gold 5μ"
SP14M1G10	SS14M1G10	14	2.0-2.5	Gold 10μ"
SP14M1G15	SS14M1G15	14	2.0-2.5	Gold 15μ"
SP14M1G30	SS14M1G30	14	2.0-2.5	Gold 30μ"
SP16M1F	SS16M1F	18-16	.75-1.5	Gold Flash
SP16M1G5	SS16M1G5	18-16	.75-1.5	Gold 5μ"
SP16M1G10	SS16M1G10	18-16	.75-1.5	Gold 10μ"
SP16M1G15	SS16M1G15	18-16	.75-1.5	Gold 15μ"
SP16M1G30	SS16M1G30	18-16	.75-1.5	Gold 30μ"
SP20M1F	SS20M1F	22-20	.34-.50	Gold Flash
SP20M1G5	SS20M1G5	22-20	.34-.50	Gold 5μ"
SP20M1G10	SS20M1G10	22-20	.34-.50	Gold 10μ"
SP20M1G15	SS20M1G15	22-20	.34-.50	Gold 15μ"
SP20M1G30	SS20M1G30	22-20	.34-.50	Gold 30μ"
SP24M1F	SS24M1F	22-20	.14-.25	Gold Flash
SP24M1G5	SS24M1G5	26-24	.14-.25	Gold 5μ"
SP24M1G10	SS24M1G10	26-24	.14-.25	Gold 10μ"
SP24M1G15	SS24M1G15	26-24	.14-.25	Gold 15μ"
SP24M1G30	SS24M1G30	26-24	.14-.25	Gold 30μ"

Tools

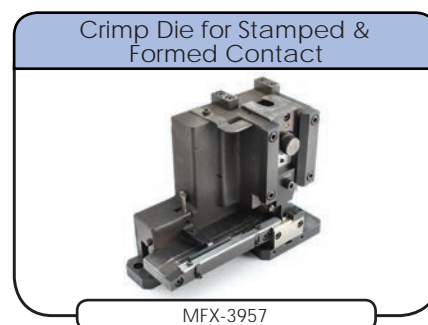

STEP 1
Choose Receptacle Style

STEP 2
Choose Plug Style

STEP 2
Choose Backshell Style

Jam Nut Receptacles



Jam Nut Receptacle Kit Including Receptacle & Contacts



OR
Square Flange Receptacles



Square Flange Receptacle Kit Including Receptacle, Gasket & Contacts



Plug



Backshell



OR
Plug Kit Including Connector, Backshell & Contacts



SEE TABLE ON NEXT PAGE FOR PART DETAILS

CONTACTS SOLD SEPARATELY SEE PAGE 42

Shell Size: 10 Number of Contacts: 4 Contact Size: Mixed 16 & 20
Sealing: IP67 Salt Spray: 48h

eco | mate® rm Standard Products

- Suitable For Indoor and Outdoor Applications
- EMI/RMI Shielding Capability with Appropriate Backshell
- Operating Temperature: -40°C to +105°C
- 500 Mating Cycles
- Contacts and Cord Grips Ordered Separately
- UL ECBT2 Certified*

An upgraded silicone seal is available for all connector parts. Please add "03" to the end of the part number when ordering. Operating Temperature: -40°C to +125°C. Not available in kits.

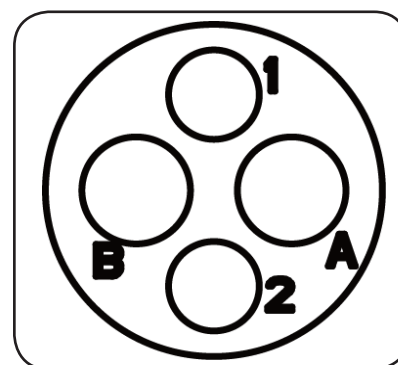

Insert Arrangement
Pin (Male) Faceview

Connector Part Numbers

Part Number		Connector Type	Figure Drawings	
Male	Female		Male	Female
RT07102PNH	RT07102SNH	Jam Nut Receptacle	1,5	2,5
RT07102PNHEC	RT07102SNHEC	Jam Nut Receptacle with O-ring Seal and End Cap with Individual Rear Wire Seal**	3,5	4,5
RT06102PNH	RT06102SNH	Plug	6	7
RT06102PNHEC	RT06102SNHEC	Plug with O-ring Seal and End Cap with Individual Rear Wire Seal**	8	9
RT00102PNH	RT00102SNH	Square Flange Receptacle	10,14	11,14
RT00102PNHEC	RT00102SNHEC	Square Flange Receptacle with O-ring Seal	12,14	13,14
RT00102PNHEC	RT00102SNHEC	Square Flange Receptacle with O-ring Seal and End Cap with Individual Rear Wire Seal**	12,14	13,14
RT00102PNHK	RT00102SNHK	Square Flange Receptacle Kit	10,14	11,14

Contacts supplied separately see page 42

**See page 39 for the real seal wire range

Backshells

Part Number	Backshell Type	Cable Range (mm)	Figure Drawings	Shielding
RT0S10CGNS1	Short Cord Grip (straight)	3-6.5	15	✓
RT0S10CGNS2	Short Cord Grip (straight)	5-8.5	15	✓
RT0L10CGNS1	Long Cord Grip (straight)	3-6.5	16	✓
RT0L10CGNS2	Long Cord Grip (straight)	5-8.5	16	✓

*Connector parts with part numbers ending in EC (with an end cap) were not available for submittal at the time of UL certification.

Shell Size: 10 Number of Contacts: 4
 Sealing: IP67 Salt Spray: 48h

Contact Size: Mixed 16 & 20

Dimensions Jam Nut Receptacle

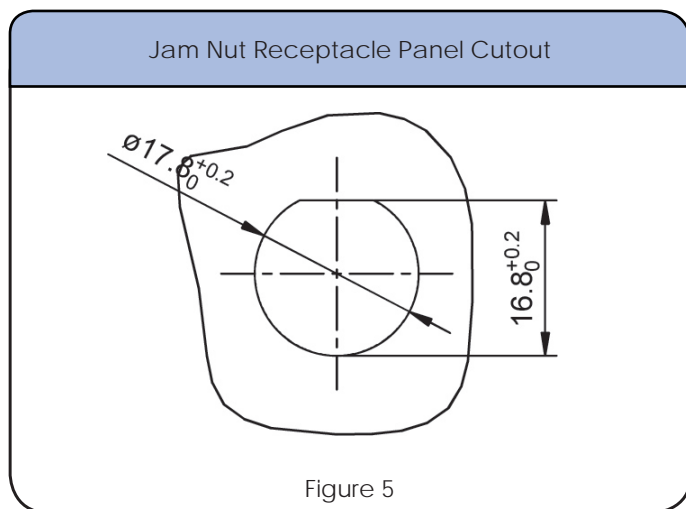
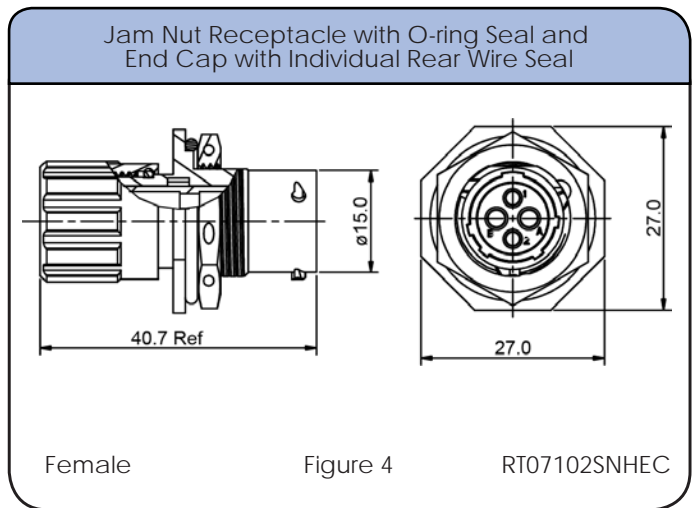
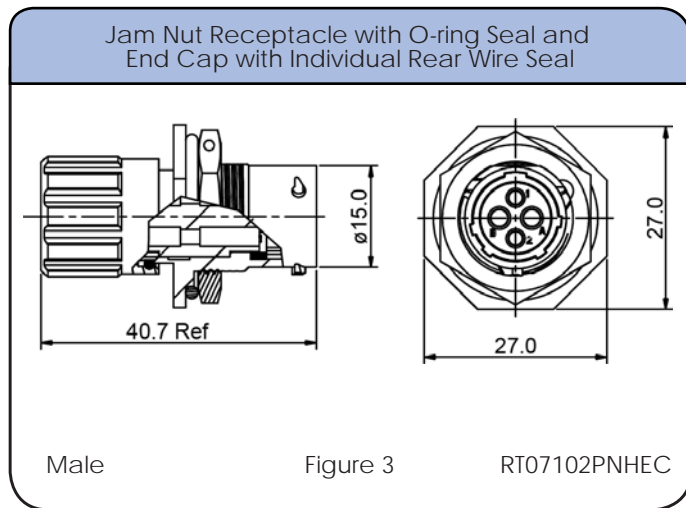
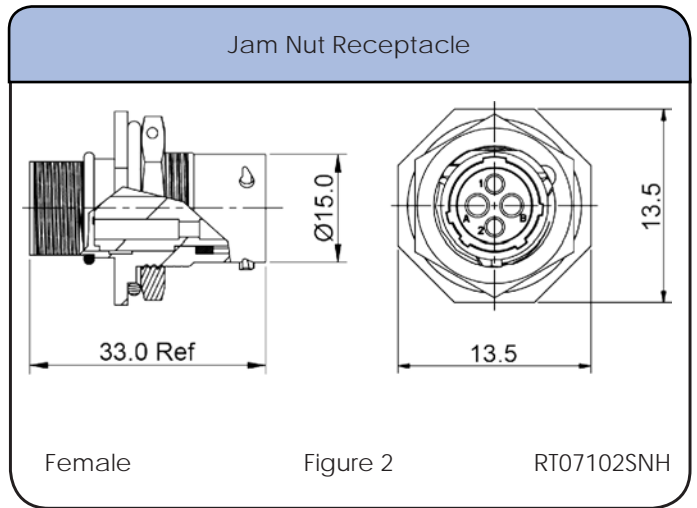
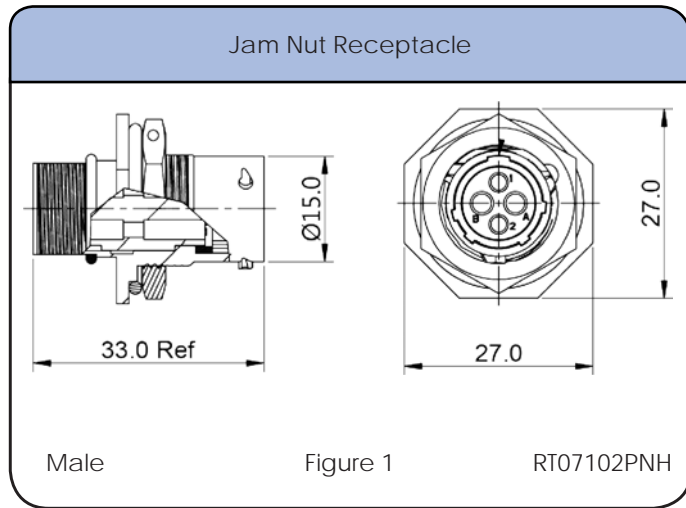

Shell Size: 10 Number of Contacts: 4
Sealing: IP67 Salt Spray: 48h

Contact Size: Mixed 16 & 20

Dimensions Plug

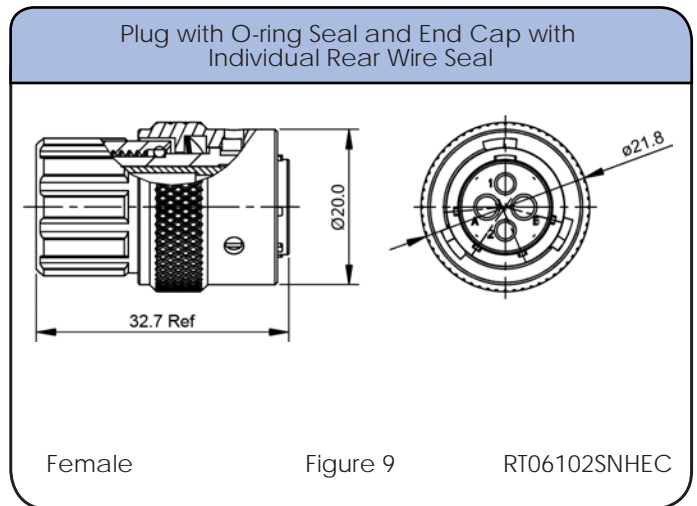
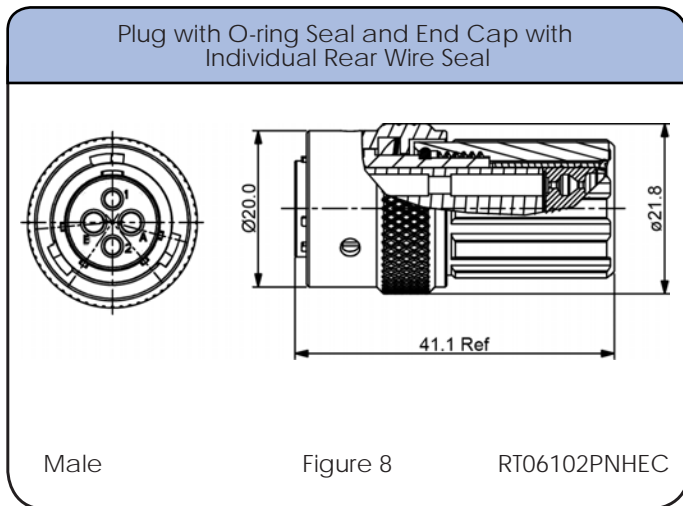
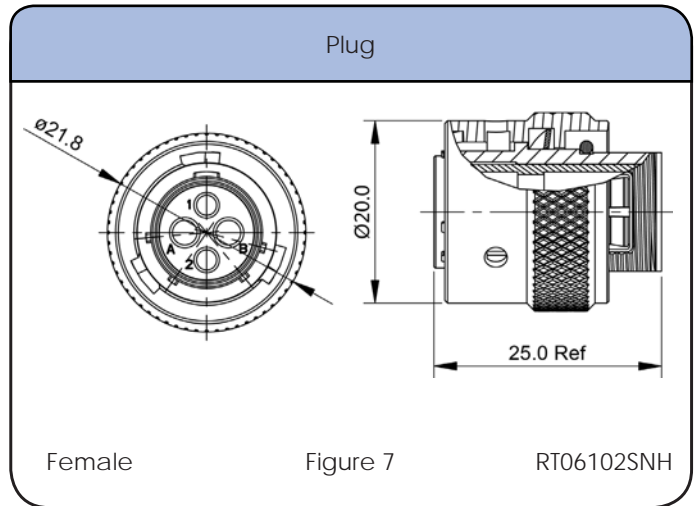
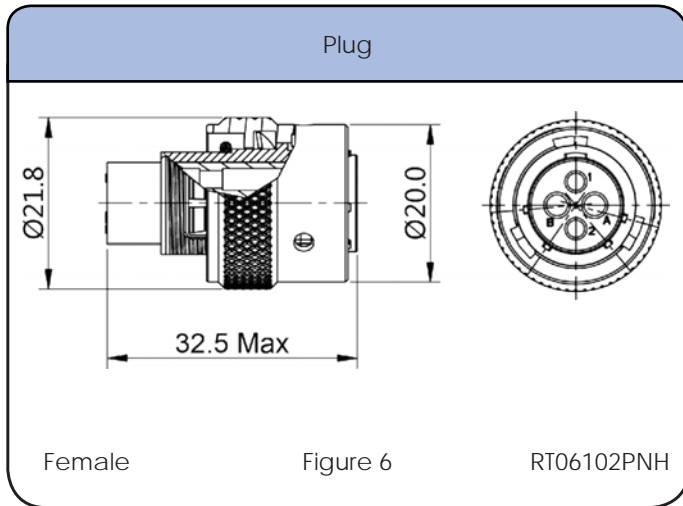

Individual Sealing Wire Range

Contact Size	Insulation Overall Diameter (min-max)	Wire Range
16	Ø2.0mm - Ø3.2mm	14 - 24 AWG
20	Ø1.6mm - Ø2.6mm	20-30 AWG

Shell Size: 10 Number of Contacts: 4 Contact Size: Mixed 16 & 20
 Sealing: IP67 Salt Spray: 48h

Dimensions Square Flange Receptacle

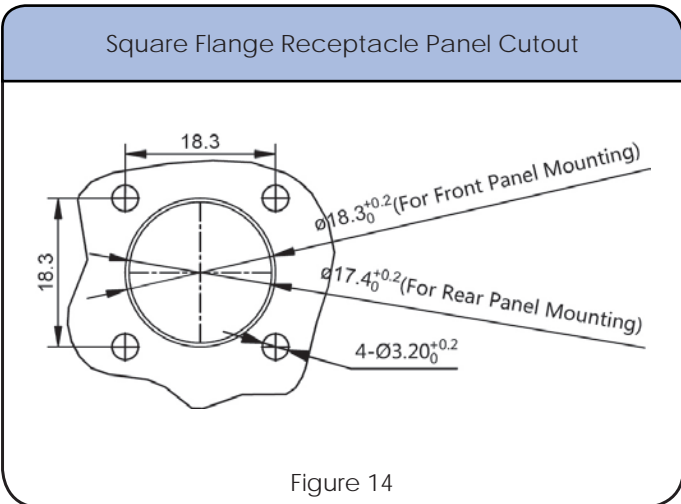
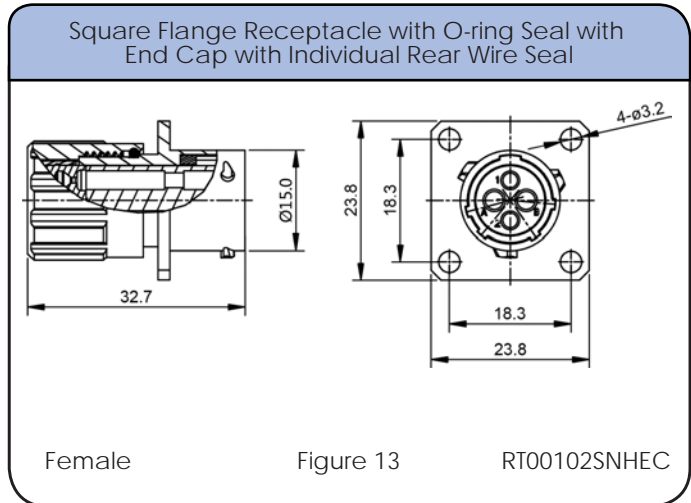
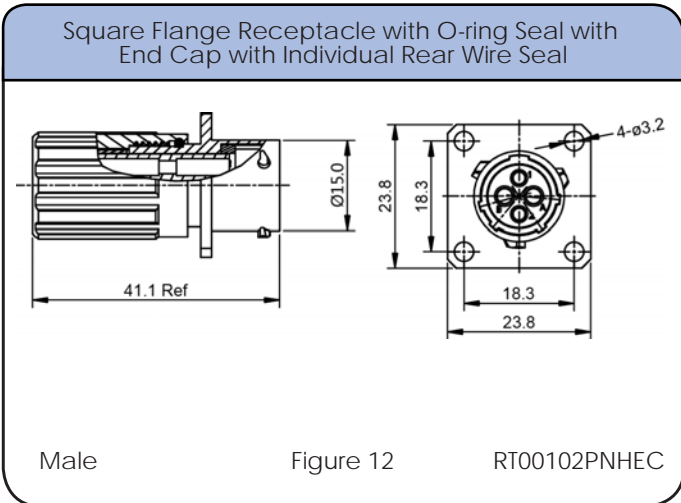
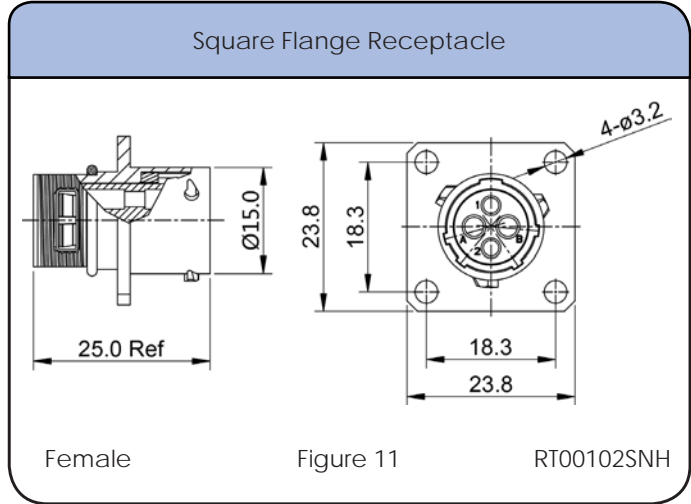
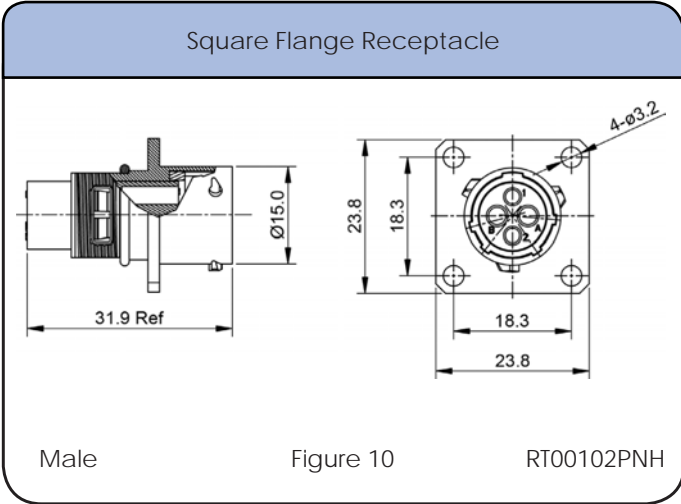

Shell Size: 10 Number of Contacts: 4 Contact Size: Mixed 16 & 20
Sealing: IP67 Salt Spray: 48h

Dimensions Backshell

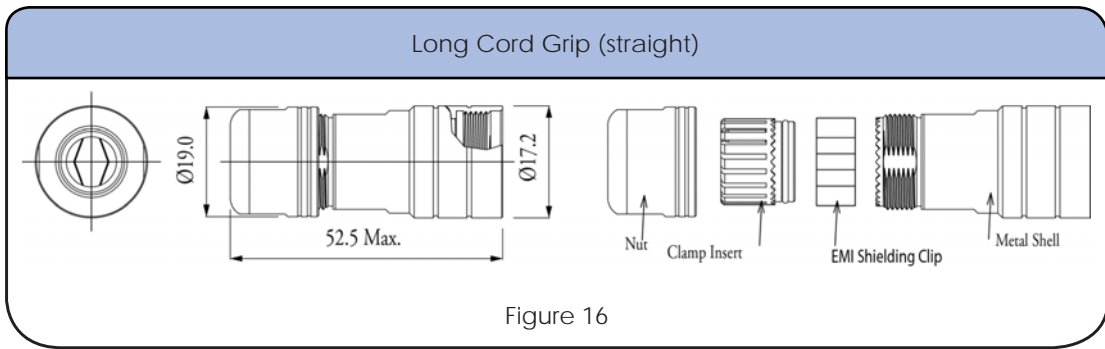
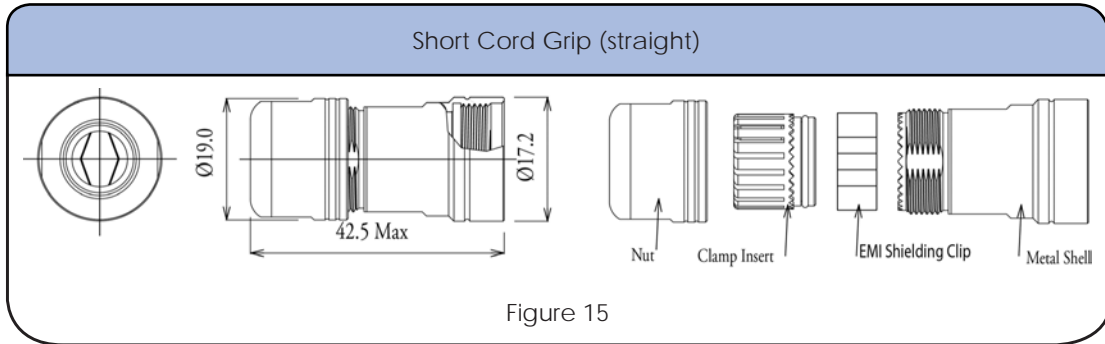

Accessories

<p>Plug Dustcap with Chain</p> <p>RT610DCG</p>	<p>Plug Dustcap without Chain</p> <p>RT610DC</p>	<p>Receptacle Dustcap with Chain</p> <p>RT010DCG</p>	<p>Receptacle Dustcap without Chain</p> <p>RT010DC</p>
<p>Receptacle Dustcap with Nylon Cord, Made of Rubber</p> <p>RT010RL</p>	<p>Receptacle Dustcap without Nylon Cord, Rubber Material</p> <p>RB00011910</p>	<p>Square Flange Receptacle Gaskets, Thickness 0.8mm (±0.2)</p> <p>RTFD10B</p>	<p>Locking Clip with Lanyard</p> <p>108039110</p>
<p>Sealing Plug</p> <p>CA402059</p>	<p>Sealing Plug</p> <p>CA401659</p>		

NEW!
See
Page
16

Shell Size: 10 Number of Contacts: 4 Contact Size: Mixed 16 & 20
 Sealing: IP67 Salt Spray: 48h

Contacts



Crimp Contacts, Machined

Part Number		Contact Size	AWG	Wire Range (mm ²)	Plating
Male	Female				
MP14M23F	MS14M23F	16	14	2.0-2.5	Gold Flash
MP14M23G5	MS14M23G5	16	14	2.0-2.5	Gold 5μ"
MP14M23G10	MS14M23G10	16	14	2.0-2.5	Gold 10μ"
MP14M23G15	MS14M23G15	16	14	2.0-2.5	Gold 15μ"
MP14M23G30	MS14M23G30	16	14	2.0-2.5	Gold 30μ"
MP16M23F	MS16M23F	16	18-16	.75-1.5	Gold Flash
MP16M23G5	MS16M23G5	16	18-16	.75-1.5	Gold 5μ"
MP16M23G10	MS16M23G10	16	18-16	.75-1.5	Gold 10μ"
MP16M23G15	MS16M23G15	16	18-16	.75-1.5	Gold 15μ"
MP16M23G30	MS16M23G30	16	18-16	.75-1.5	Gold 30μ"
MP20M23F	MS20M23F	16	22-20	.34-.50	Gold Flash
MP20M23G5	MS20M23G5	16	22-20	.34-.50	Gold 5μ"
MP20M23G10	MS20M23G10	16	22-20	.34-.50	Gold 10μ"
MP20M23G15	MS20M23G15	16	22-20	.34-.50	Gold 15μ"
MP20M23G30	MS20M23G30	16	22-20	.34-.50	Gold 30μ"
MP24M23F	MS24M23F	16	26-24	.14-.25	Gold Flash
MP24M23G5	MS24M23G5	16	26-24	.14-.25	Gold 5μ"
MP24M23G10	MS24M23G10	16	26-24	.14-.25	Gold 10μ"
MP24M23G15	MS24M23G15	16	26-24	.14-.25	Gold 15μ"
MP24M23G30	MS24M23G30	16	26-24	.14-.25	Gold 30μ"

Shell Size: 10 Number of Contacts: 4 Contact Size: Mixed 16 & 20
Sealing: IP67 Salt Spray: 48h

Crimp Contacts Machined (con't)



Part Number		Contact Size	AWG	Wire Range (mm ²)	Plating
Male	Female				
MP20W23F	MS20W23F	20	22-20	.34-.50	Gold Flash
MP20W23G5	MS20W23G5	20	22-20	.34-.50	Gold 5μ"
MP20W23G10	MS20W23G10	20	22-20	.34-.50	Gold 10μ"
MP20W23G15	MS20W23G15	20	22-20	.34-.50	Gold 15μ"
MP20W23G30	MS20W23G30	20	22-20	.34-.50	Gold 30μ"
MP24W23F	MS24W23F	20	.13-.25	26-24	Gold Flash
MP24W23G5	MS24W23G5	20	.13-.25	26-24	Gold 5μ"
MP24W23G10	MS24W23G10	20	.13-.25	26-24	Gold 10μ"
MP24W23G15	MS24W23G15	20	.13-.25	26-24	Gold 15μ"
MP24W23G30	MS24W23G30	20	.13-.25	26-24	Gold 30μ"
MP28W23F	MS28W23F	20	30-28	.05-.08	Gold Flash
MP28W23G5	MS28W23G5	20	30-28	.05-.08	Gold 5μ"
MP28W23G10	MS28W23G10	20	30-28	.05-.08	Gold 10μ"
MP28W23G15	MS28W23G15	20	30-28	.05-.08	Gold 15μ"
MP28W23G30	MS28W23G30	20	30-28	.05-.08	Gold 30μ"

Tools



Shell Size: 10 Number of Contacts: 4 Contact Size: Mixed 16 & 20
 Sealing: IP67 Salt Spray: 48h

Contacts (con't)



Crimp Contacts, Stamped & Formed

Part Number		Contact Size	AWG	Max Wire (mm ²)	Plating
Male	Female				
SP14M1F	SS14M1F	16	14	2.0-2.5	Gold Flash
SP14M1G5	SS14M1G5	16	14	2.0-2.5	Gold 5μ"
SP14M1G10	SS14M1G10	16	14	2.0-2.5	Gold 10μ"
SP14M1G15	SS14M1G15	16	14	2.0-2.5	Gold 15μ"
SP14M1G30	SS14M1G30	16	14	2.0-2.5	Gold 30μ"
SP16M1F	SS16M1F	16	18-16	.75-1.5	Gold Flash
SP16M1G5	SS16M1G5	16	18-16	.75-1.5	Gold 5μ"
SP16M1G10	SS16M1G10	16	18-16	.75-1.5	Gold 10μ"
SP16M1G15	SS16M1G15	16	18-16	.75-1.5	Gold 15μ"
SP16M1G30	SS16M1G30	16	18-16	.75-1.5	Gold 30μ"
SP20M1F	SS20M1F	16	22-20	.34-.50	Gold Flash
SP20M1G5	SS20M1G5	16	22-20	.34-.50	Gold 5μ"
SP20M1G10	SS20M1G10	16	22-20	.34-.50	Gold 10μ"
SP20M1G15	SS20M1G15	16	22-20	.34-.50	Gold 15μ"
SP20M1G30	SS20M1G30	16	22-20	.34-.50	Gold 30μ"
SP24M1F	SS24M1F	16	22-20	.14-.25	Gold Flash
SP24M1G5	SS24M1G5	16	26-24	.14-.25	Gold 5μ"
SP24M1G10	SS24M1G10	16	26-24	.14-.25	Gold 10μ"
SP24M1G15	SS24M1G15	16	26-24	.14-.25	Gold 15μ"
SP24M1G30	SS24M1G30	16	26-24	.14-.25	Gold 30μ"

Shell Size: 10 Number of Contacts: 4 Contact Size: Mixed 16 & 20
Sealing: IP67 Salt Spray: 48h

Crimp Contacts, Stamped & Formed (con't)

Part Number		Contact Size	AWG	Max Wire (mm ²)	Plating
Male	Female				
SP20W1F	SS20W1F	20	22-20	.34-.50	Gold Flash
SP20W1G10	SS20W1G10	20	22-20	.34-.50	Gold 10μ"
SP20W1G15	SS20W1G15	20	22-20	.34-.50	Gold 15μ"
SP20W1G30	SS20W1G30	20	22-20	.34-.50	Gold 30μ"
SP20W1G5	SS20W1G5	20	22-20	.34-.50	Gold 5μ"
SP24W1F	SS24W1F	20	26-24	.14-.25	Gold Flash
SP24W1G5	SS24W1G5	20	26-24	.14-.25	Gold 5μ"
SP24W1G10	SS24W1G10	20	26-24	.14-.25	Gold 10μ"
SP24W1G15	SS24W1G15	20	26-24	.14-.25	Gold 15μ"
SP24W1G30	SS24W1G30	20	26-24	.14-.25	Gold 30μ"
SP28W1F	SS28W1F	20	30-28	.05-.08	Gold Flash
SP28W1G5	SS28W1G5	20	30-28	.05-.08	Gold 5μ"
SP28W1G10	SS28W1G10	20	30-28	.05-.08	Gold 10μ"
SP28W1G15	SS28W1G15	20	30-28	.05-.08	Gold 15μ"
SP28W1G30	SS28W1G30	20	30-28	.05-.08	Gold 30μ"

Tools



STEP 1
Choose Receptacle Style

STEP 2
Choose Plug Style

STEP 2
Choose Backshell Style

Jam Nut Receptacles



OR
Square Flange Receptacles



Plug



Backshell



SEE TABLE ON NEXT PAGE FOR PART DETAILS

CONTACTS SOLD SEPARATELY SEE PAGE 52

Shell Size: 14 Number of Contacts: 4 Contact Size: Mixed 2.5mm & 16
Sealing: IP67 Salt Spray: 48h

eco | mate[®] rm Standard Products

- Suitable For Indoor and Outdoor Applications
- EMI/RMI Shielding Capability with Appropriate Backshell
- Operating Temperature: -40°C to +105°C
- 500 Mating Cycles
- Contacts and Cord Grips Ordered Separately
- UL ECBT2 Certified*

An upgraded silicone seal is available for all connector parts. Please add "03" to the end of the part number when ordering. Operating Temperature: -40°C to +125°C. Not available in kits.

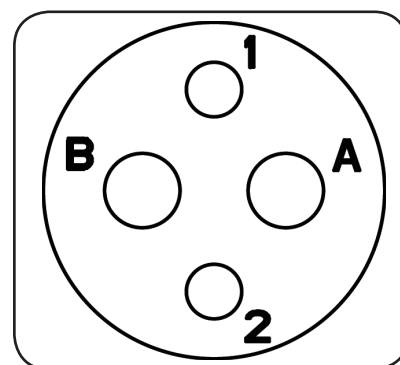

Insert Arrangement
Pin (Male) Faceview

Connector Part Numbers

Part Number		Connector Type	Figure Drawings	
Male	Female		Male	Female
RT07142PNH	RT07142SNH	Jam Nut Receptacle with O-ring Seal	1,5	2,5
RT07142PNHEC	RT07142SNHEC	Jam Nut Receptacle with O-ring Seal and End Cap with Individual Rear Wire Seal**	3,5	4,5
RT06142PNH	RT06142SNH	Plug with O-ring Seal	6	7
RT06142PNHEC	RT06142SNHEC	Plug with O-ring Seal and End Cap with Individual Rear Wire Seal**	8	9
RT00142PNH	RT00142SNH	Square Flange Receptacle	10,14	11,14
RT00142PNHEC	RT00142SNHEC	Square Flange Receptacle with O-ring Seal and End Cap with Individual Rear Wire Seal**	12,14	13,14

Contacts supplied separately see page 52

**See page 49 for the real seal wire range

Backshells

Part Number	Backshell Type	Cable Range (mm)	Figure Drawings	Shielding
RTOS14CGNS1	Short Cord Grip (straight)	6-10.5	15	✓
RTOS14CGNS2	Short Cord Grip (straight)	8.5-12.5	15	✓
RTOL14CGNS1	Long Cord Grip (straight)	6-10.5	16	✓
RTOL14CGNS2	Long Cord Grip (straight)	8.5-12.5	16	✓
RTOB14CGNS1	Cord Grip (90°)	6-10.5	17	✓
RTOB14CGNS2	Cord Grip (90°)	8.0-12.5	17	✓

*Connector parts with part numbers ending in EC (with an end cap) were not available for submittal at the time of UL certification.

Shell Size: 14 Number of Contacts: 4
 Sealing: IP67 Salt Spray: 48h

Contact Size: Mixed 2.5mm & 16

Dimensions Jam Nut Receptacle

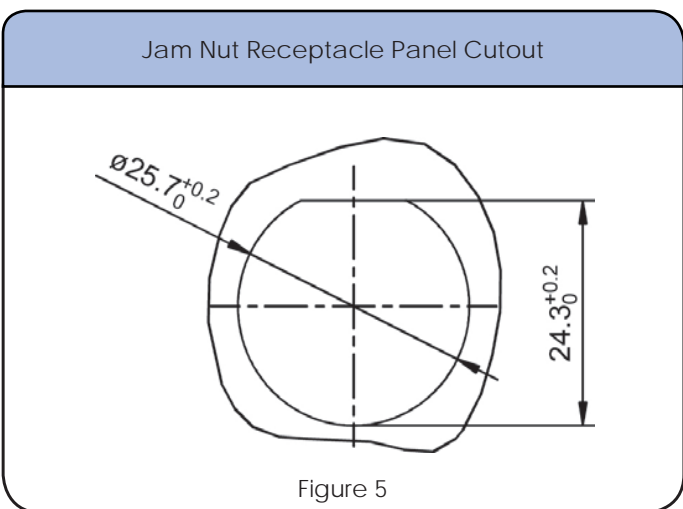
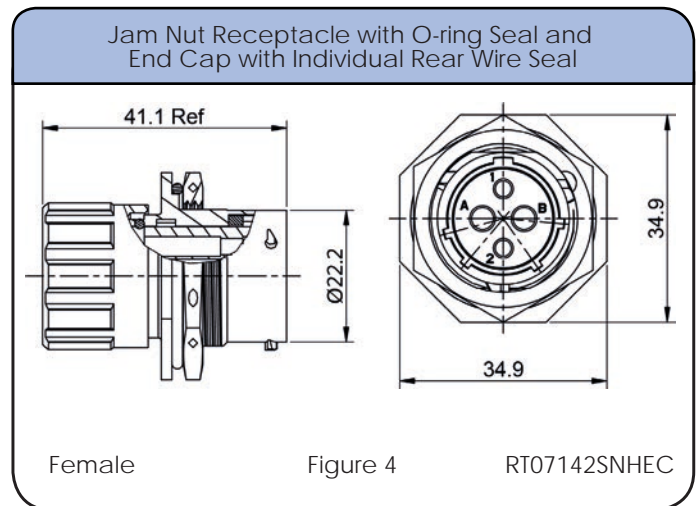
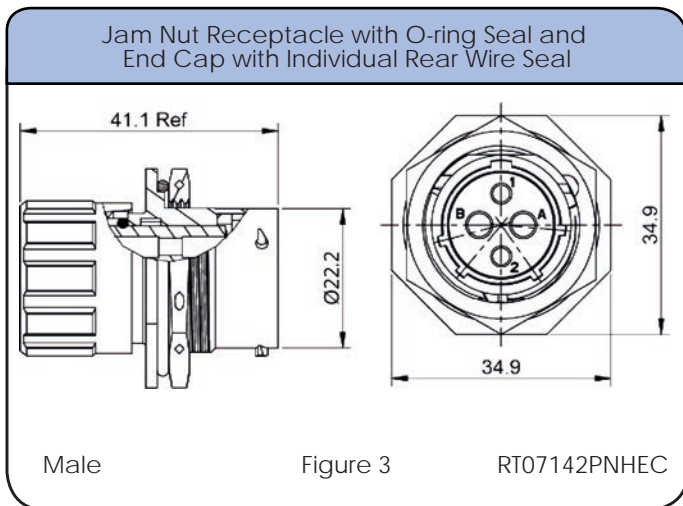
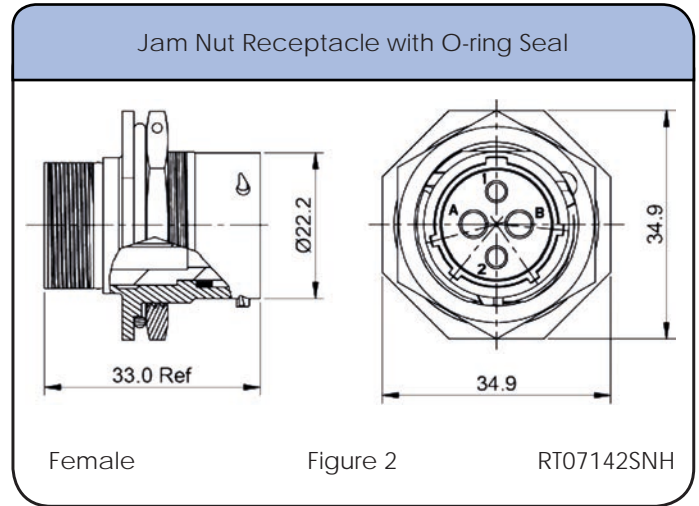
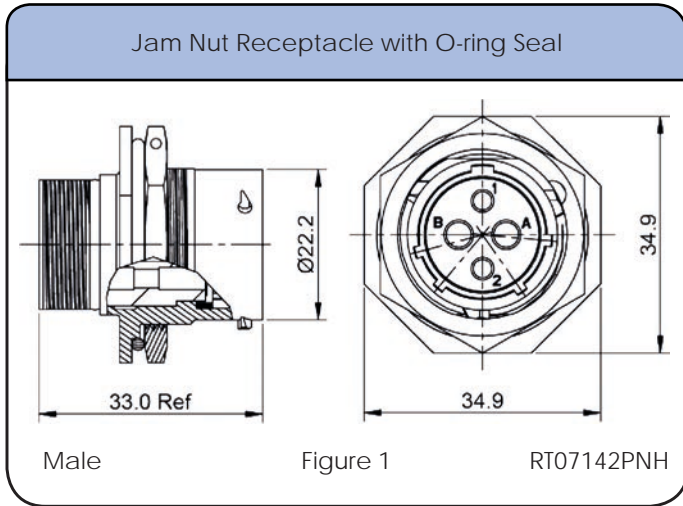

Shell Size: 14 Number of Contacts: 4
Sealing: IP67 Salt Spray: 48h

Contact Size: Mixed 2.5mm & 16

Dimensions Plug

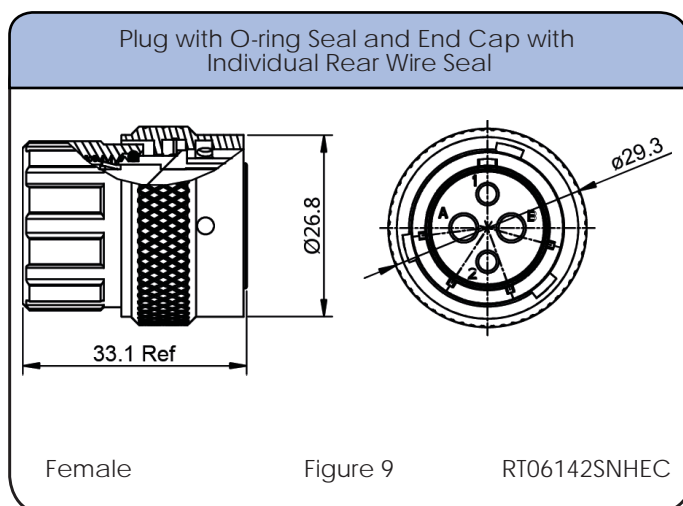
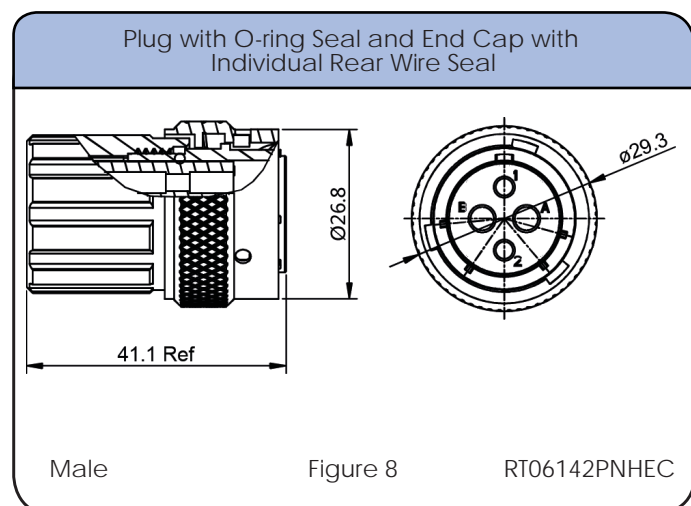
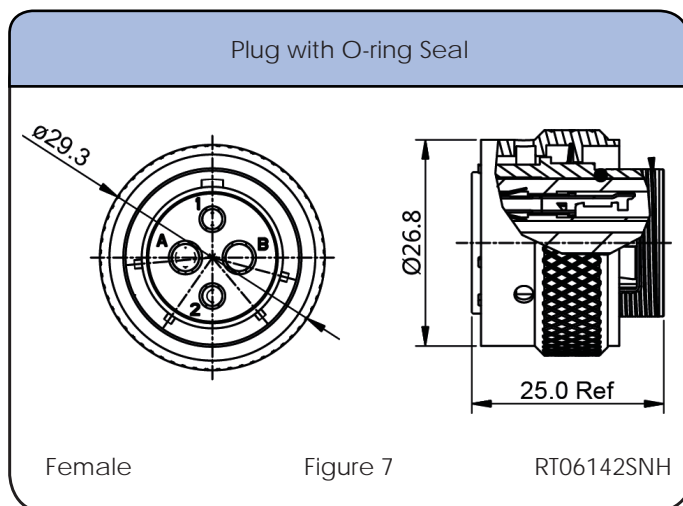
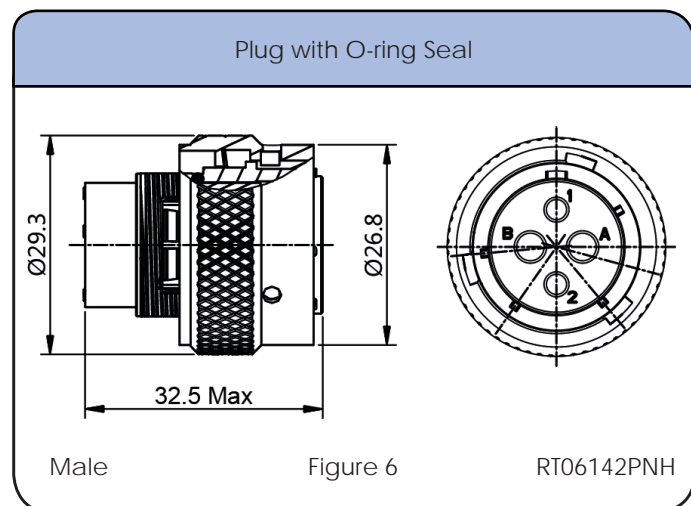

Individual Sealing Wire Range

Contact Size	Insulation Overall Diameter (min-max)	Wire Range
2.5mm	Ø3.3mm - Ø4.3mm	14 - 12 AWG
16	Ø2.0mm - Ø3.2mm	14 - 24 AWG

Shell Size: 14 Number of Contacts: 4 Contact Size: Mixed 2.5mm & 16
 Sealing: IP67 Salt Spray: 48h

Dimensions Square Flange Receptacle

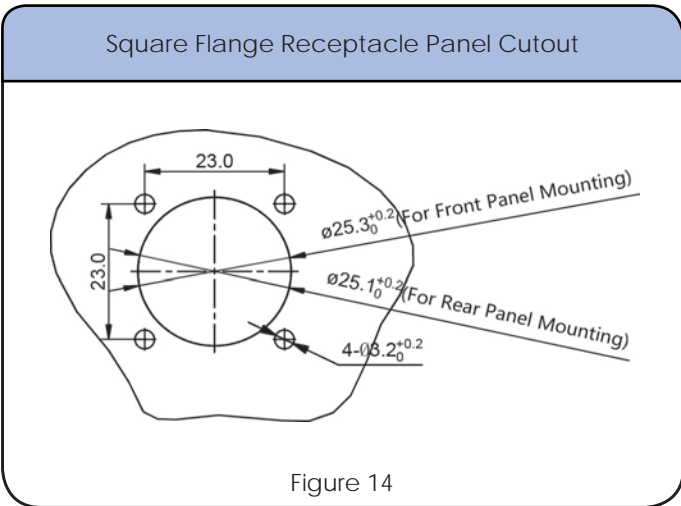
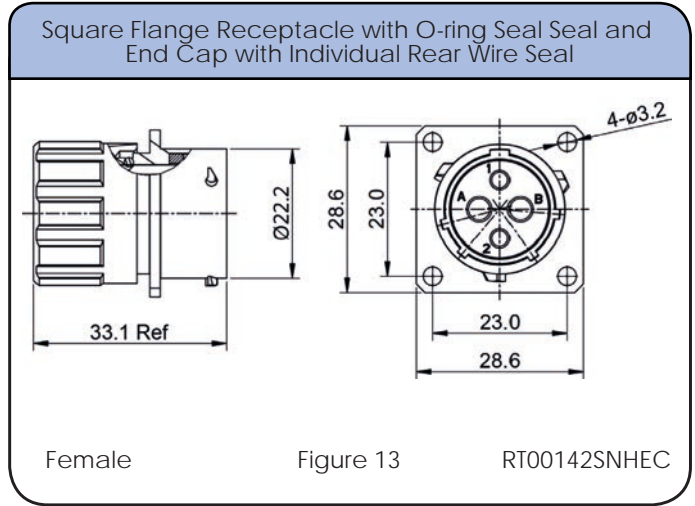
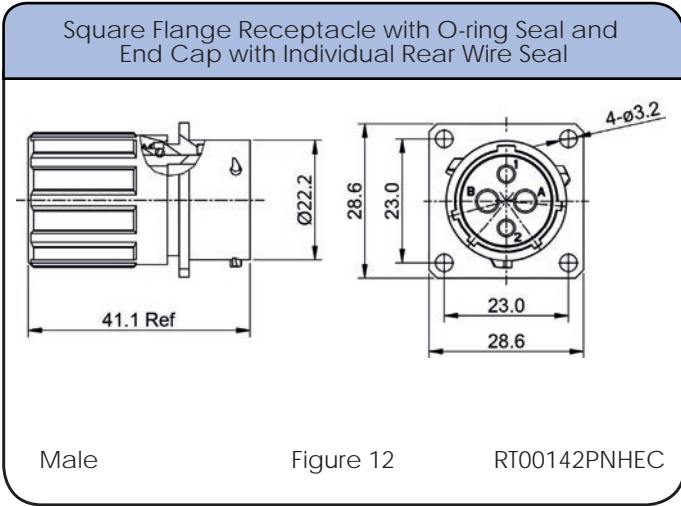
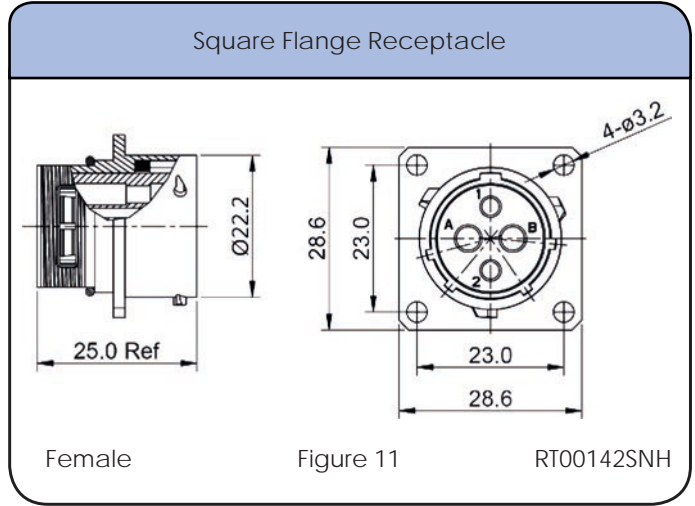
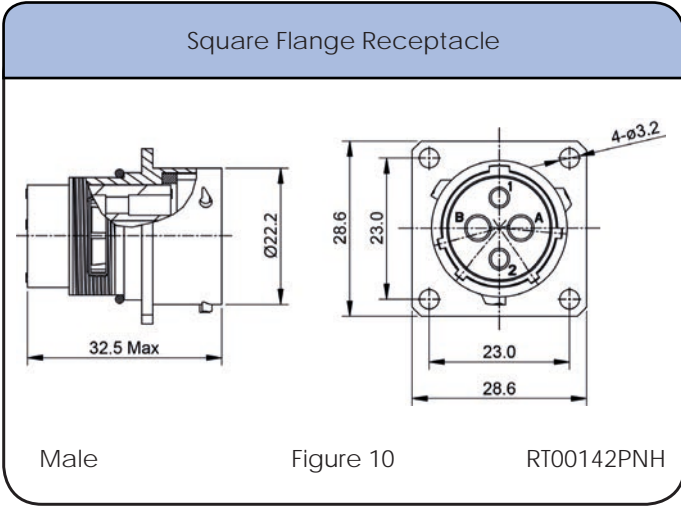

Shell Size: 14 Number of Contacts: 4 Contact Size: Mixed 2.5mm & 16
Sealing: IP67 Salt Spray: 48h

Dimensions Backshell

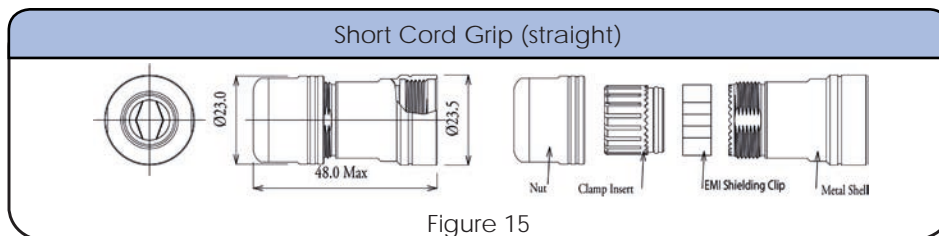

Figure 15

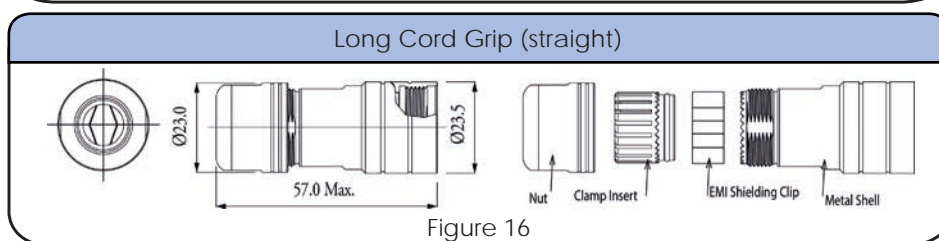

Figure 16

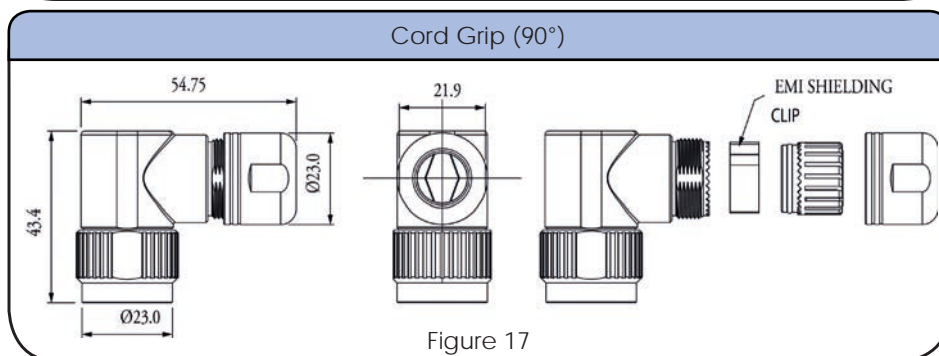











Figure 17

Accessories

<p>Locking Clip with Lanyard</p>  <p>108039114</p>	<p>Plug Dustcap with Chain</p>  <p>RT614DCG</p>	<p>Plug Dustcap without Chain</p>  <p>RT614DC</p>	<p>Receptacle Dustcap with Chain</p>  <p>RT014DCG</p>
<p>Receptacle Dustcap with Nylon Cord, Made of Rubber</p>  <p>RT014RL</p>	<p>Receptacle Dustcap without Chain</p>  <p>RT014DC</p>	<p>Receptacle Dustcap without Nylon Cord, Rubber Material</p>  <p>RB00011914</p>	<p>Sealing Plug</p>  <p>CA401659</p>
<p>Sealing Plug</p>  <p>CA401659</p>	<p>Square Flange Receptacle Gaskets, Thickness 0.8mm (±0.2)</p>  <p>RTFD14B</p>		

NEW!
See
Page
16

Shell Size: 14
Sealing: IP67

Number of Contacts: 4
Salt Spray: 48h

Contact Size: Mixed 2.5mm & 16

Contacts



Crimp Contacts, Machined

Part Number		Contact Size	AWG	Wire Range (mm ²)	Plating
Male	Female				
MP14M23F	MS14M23F	16	14	2.0-2.5	Gold Flash
MP14M23G5	MS14M23G5	16	14	2.0-2.5	Gold 5μ"
MP14M23G10	MS14M23G10	16	14	2.0-2.5	Gold 10μ"
MP14M23G15	MS14M23G15	16	14	2.0-2.5	Gold 15μ"
MP14M23G30	MS14M23G30	16	14	2.0-2.5	Gold 30μ"
MP16M23F	MS16M23F	16	18-16	.75-1.5	Gold Flash
MP16M23G5	MS16M23G5	16	18-16	.75-1.5	Gold 5μ"
MP16M23G10	MS16M23G10	16	18-16	.75-1.5	Gold 10μ"
MP16M23G15	MS16M23G15	16	18-16	.75-1.5	Gold 15μ"
MP16M23G30	MS16M23G30	16	18-16	.75-1.5	Gold 30μ"
MP20M23F	MS20M23F	16	22-20	.34-.50	Gold Flash
MP20M23G5	MS20M23G5	16	22-20	.34-.50	Gold 5μ"
MP20M23G10	MS20M23G10	16	22-20	.34-.50	Gold 10μ"
MP20M23G15	MS20M23G15	16	22-20	.34-.50	Gold 15μ"
MP20M23G30	MS20M23G30	16	22-20	.34-.50	Gold 30μ"
MP24M23F	MS24M23F	16	26-24	.14-.25	Gold Flash
MP24M23G5	MS24M23G5	16	26-24	.14-.25	Gold 5μ"
MP24M23G10	MS24M23G10	16	26-24	.14-.25	Gold 10μ"
MP24M23G15	MS24M23G15	16	26-24	.14-.25	Gold 15μ"
MP24M23G30	MS24M23G30	16	26-24	.14-.25	Gold 30μ"

Tools



Shell Size: 14 Number of Contacts: 4
Sealing: IP67 Salt Spray: 48h

Contact Size: Mixed 2.5mm & 16

Contacts (con't)



Crimp Contacts, Stamped & Formed

Part Number		Contact Size	AWG	Wire Range (mm ²)	Plating
Male	Female				
SP12A1T	SS12A1T	2.5mm	14-12	2.5-3.5	Tin
SP14M1F	SS14M1F	16	14	2.0-2.5	Gold Flash
SP14M1G5	SS14M1G5	16	14	2.0-2.5	Gold 5μ"
SP14M1G10	SS14M1G10	16	14	2.0-2.5	Gold 10μ"
SP14M1G15	SS14M1G15	16	14	2.0-2.5	Gold 15μ"
SP14M1G30	SS14M1G30	16	14	2.0-2.5	Gold 30μ"
SP16M1F	SS16M1F	16	18-16	.75-1.5	Gold Flash
SP16M1G5	SS16M1G5	16	18-16	.75-1.5	Gold 5μ"
SP16M1G10	SS16M1G10	16	18-16	.75-1.5	Gold 10μ"
SP16M1G15	SS16M1G15	16	18-16	.75-1.5	Gold 15μ"
SP16M1G30	SS16M1G30	16	18-16	.75-1.5	Gold 30μ"
SP20M1F	SS20M1F	16	22-20	.34-.50	Gold Flash
SP20M1G5	SS20M1G5	16	22-20	.34-.50	Gold 5μ"
SP20M1G10	SS20M1G10	16	22-20	.34-.50	Gold 10μ"
SP20M1G15	SS20M1G15	16	22-20	.34-.50	Gold 15μ"
SP20M1G30	SS20M1G30	16	22-20	.34-.50	Gold 30μ"
SP24M1F	SS24M1F	16	22-20	.14-.25	Gold Flash
SP24M1G5	SS24M1G5	16	26-24	.14-.25	Gold 5μ"
SP24M1G10	SS24M1G10	16	26-24	.14-.25	Gold 10μ"
SP24M1G15	SS24M1G15	16	26-24	.14-.25	Gold 15μ"
SP24M1G30	SS24M1G30	16	26-24	.14-.25	Gold 30μ"

Tools

Extraction Tool 2.5mm Contact



QXRT12S

Contact Extraction Tool, #16 (Ø 1.6) Contact



QXRT16

Hand Tool, Stamped & Formed Contact, 2.5 mm



MFX-3962

Hand Tool, Stamped & Formed Contact, Size 16



MFX-3954

Crimp Die for Stamped & Formed Contact



MFX-3957

STEP 1
Choose Receptacle Style

STEP 2
Choose Plug Style

STEP 2
Choose Backshell Style

Jam Nut Receptacles



OR
Square Flange Receptacles



Plug



Backshell



SEE TABLE ON NEXT PAGE FOR PART DETAILS

CONTACTS SOLD SEPARATELY SEE PAGE 60

Shell Size: 14 Number of Contacts: 4 Contact Size: 2.5mm
Sealing: IP67 Salt Spray: 48h

eco | mate[®] rm Standard Products

- Suitable For Indoor and Outdoor Applications
- EMI/RMI Shielding Capability with Appropriate Backshell
- Operating Temperature: -40°C to +105°C
- 500 Mating Cycles
- Contacts and Cord Grips Ordered Separately
- UL ECBT2 Certified*

An upgraded silicone seal is available for all connector parts. Please add "03" to the end of the part number when ordering. Operating Temperature: -40°C to +125°C. Not available in kits.

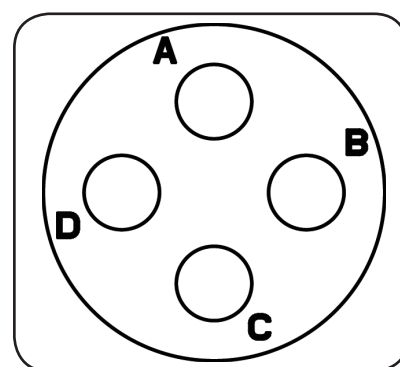

Insert Arrangement
Pin (Male) Faceview

Connector Part Numbers

Part Number		Connector Type	Figure Drawings	
Male	Female		Male	Female
RT07144PNH	RT07144SNH	Jam Nut Receptacle	1,5	2,5
RT07144PNHEC	RT07144SNHEC	Jam Nut Receptacle with O-ring Seal and End Cap with Individual Rear Wire Seal**	3,5	4,5
RT06144PNH	RT06144SNH	Plug	6	7
RT06144PNHEC	RT06144SNHEC	Plug with O-ring Seal and End Cap with Individual Rear Wire Seal**	8	9
RT00144PNH	RT00144SNH	Square Flange Receptacle	10	11,14
RT00144PNHEC	RT00144SNHEC	Square Flange Receptacle with O-ring Seal and End Cap with Individual Rear Wire Seal**	12,14	13,14

Contacts supplied separately see page 60

**See page 57 for the real seal wire range

Backshells

Part Number	Backshell Type	Cable Range (mm)	Figure Drawings	Shielding
RT0S14CGNS1	Short Cord Grip (straight)	6-10.5	15	✓
RT0S14CGNS2	Short Cord Grip (straight)	8.5-12.5	15	✓
RT0L14CGNS1	Long Cord Grip (straight)	6-10.5	16	✓
RT0L14CGNS2	Long Cord Grip (straight)	8.5-12.5	16	✓
RT0B14CGNS1	Cord Grip (90°)	6-10.5	17	✓
RT0B14CGNS2	Cord Grip (90°)	8.0-12.5	17	✓

*Connector parts with part numbers ending in EC (with an end cap) were not available for submittal at the time of UL certification.

Shell Size: 14 Number of Contacts: 4
 Sealing: IP67 Salt Spray: 48h

Contact Size: 2.5mm

Dimensions Jam Nut Receptacle

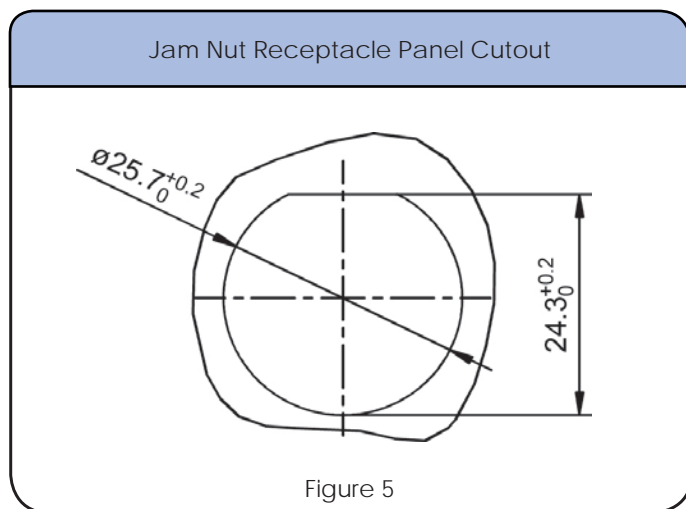
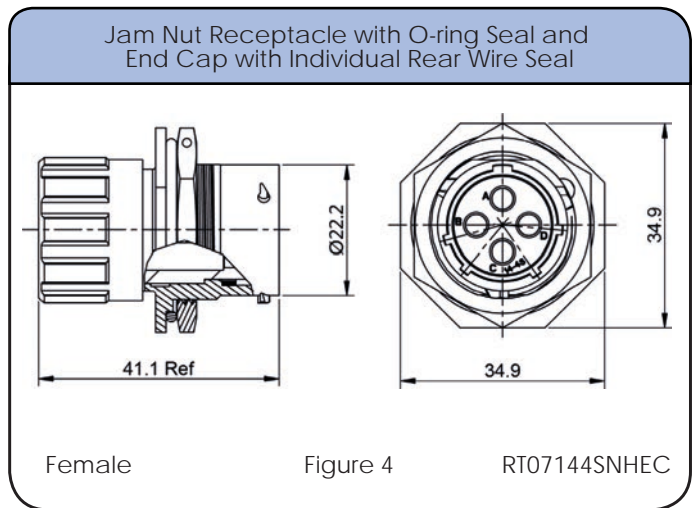
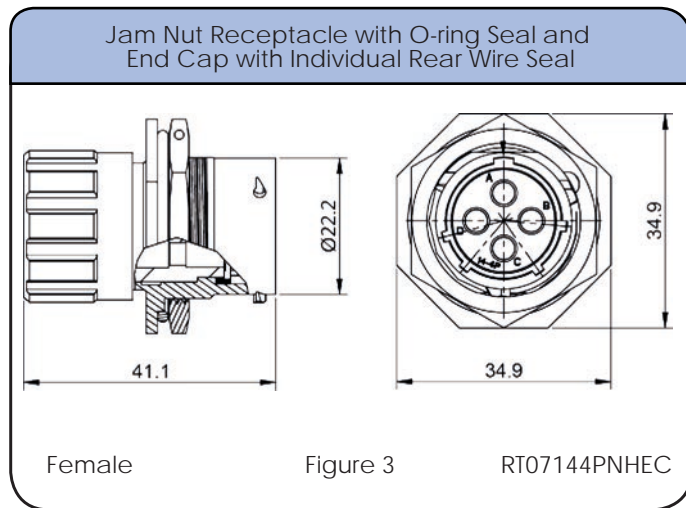
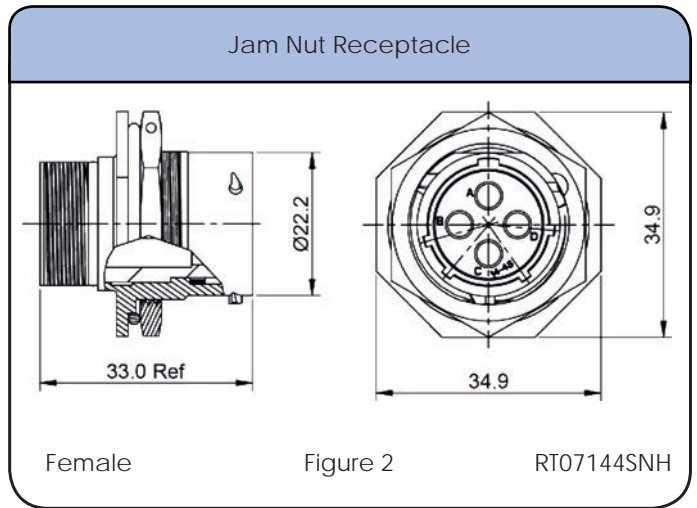
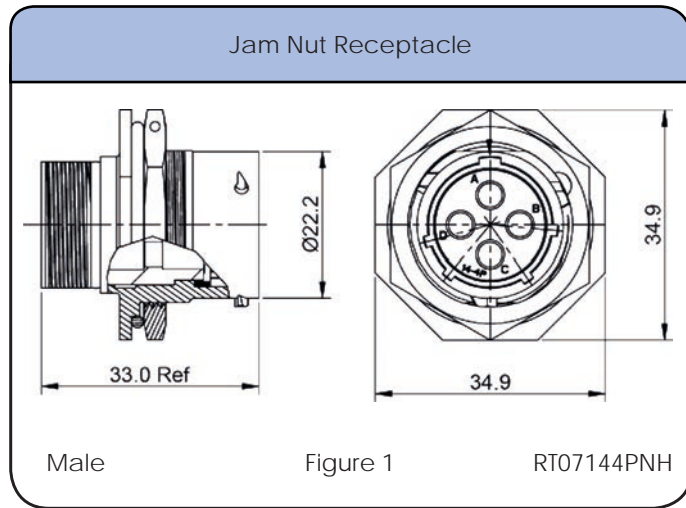

Shell Size: 14 Number of Contacts: 4
Sealing: IP67 Salt Spray: 48h

Contact Size: 2.5mm

Dimensions Plug

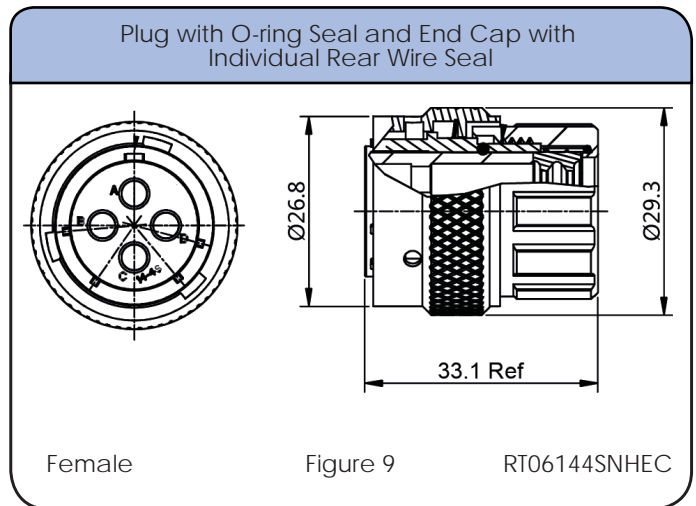
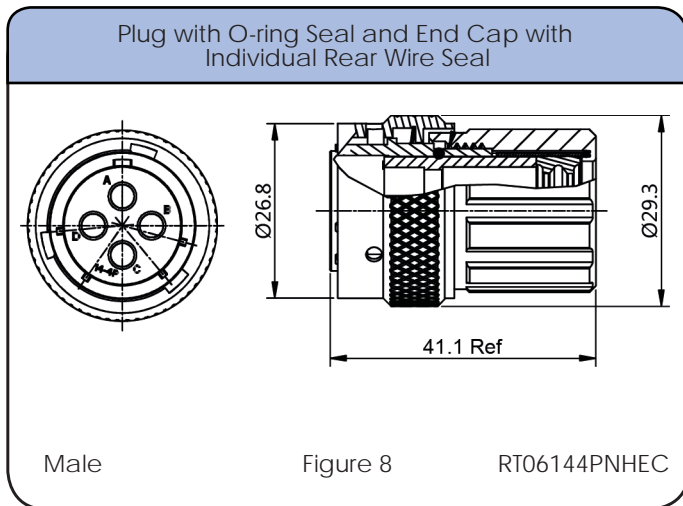
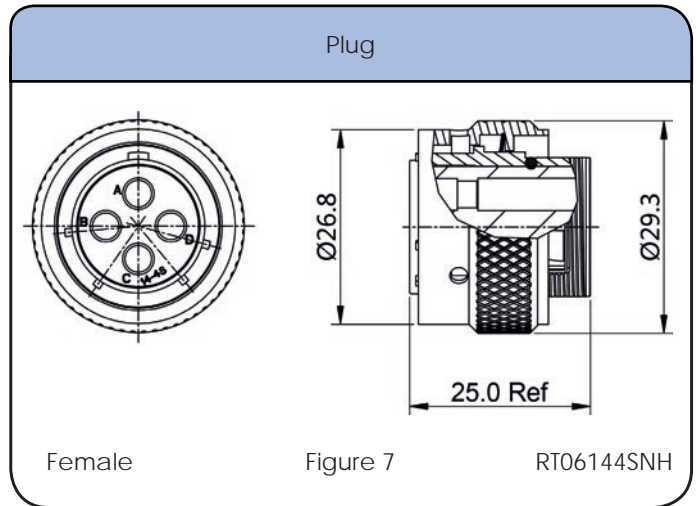
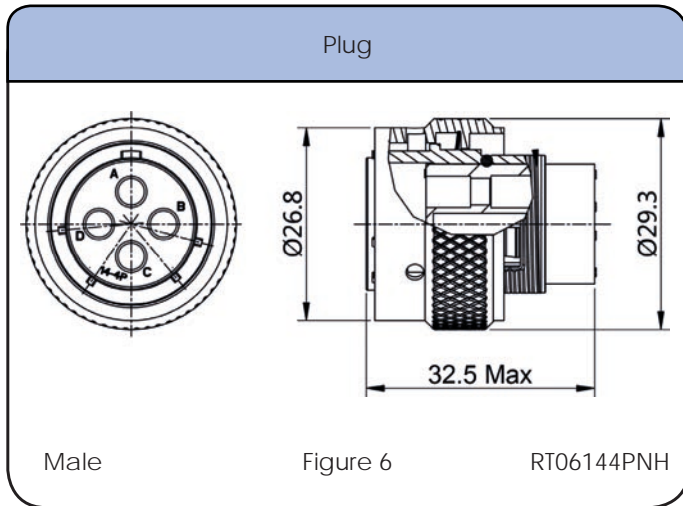

Individual Sealing Wire Range

Contact Size	Insulation Overall Diameter (min-max)	Wire Range
2.5mm	Ø3.3mm - Ø4.3mm	14 - 12 AWG

Shell Size: 14 Number of Contacts: 4 Contact Size: 2.5mm
 Sealing: IP67 Salt Spray: 48h

Dimensions Square Flange Receptacle

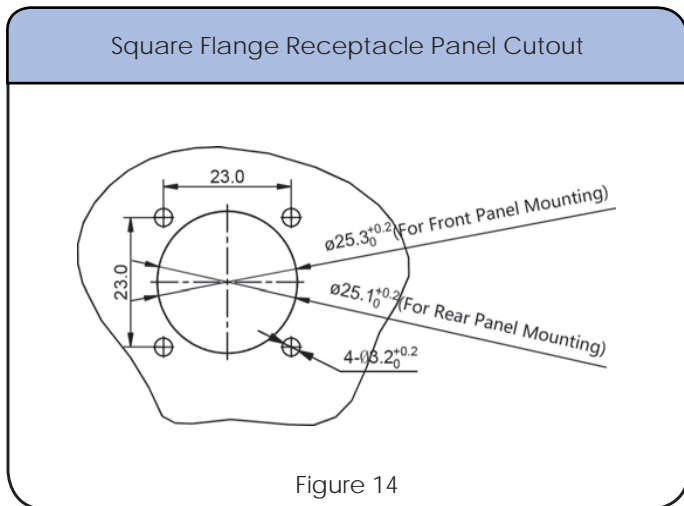
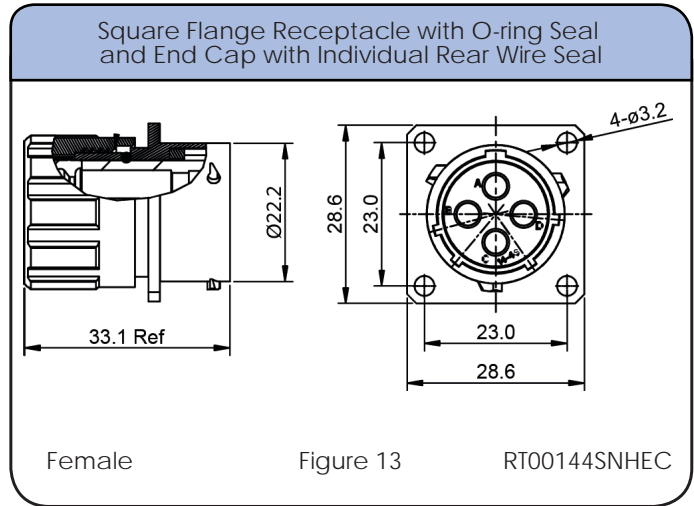
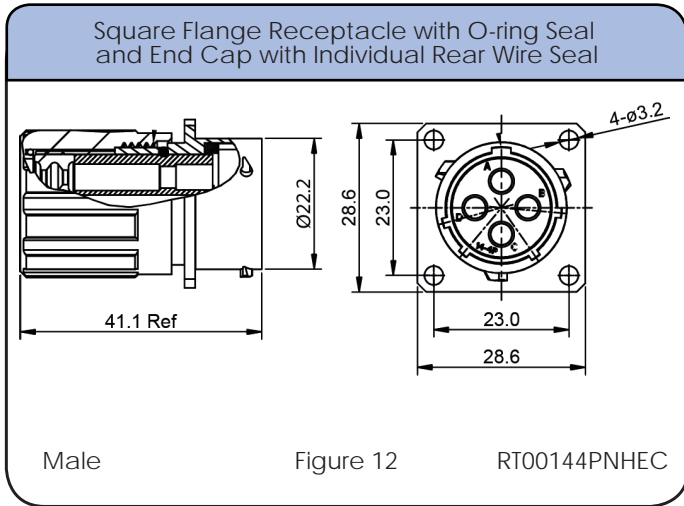
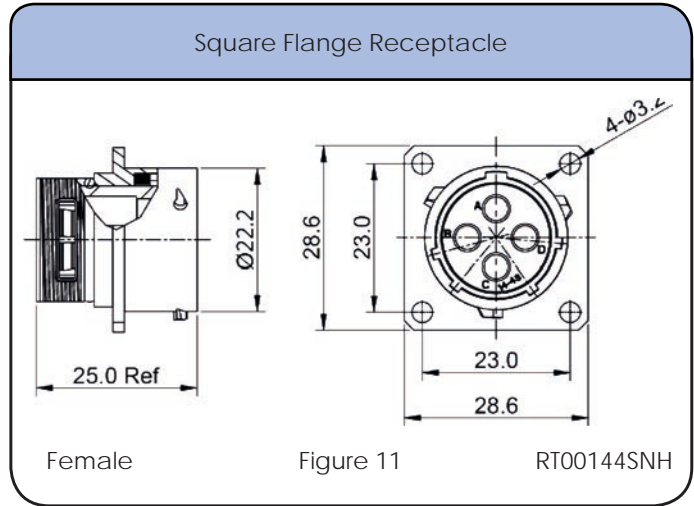
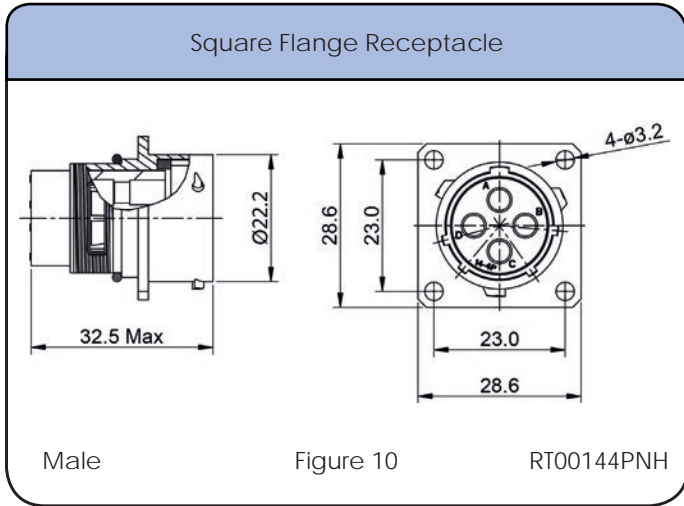

Shell Size: 14 Number of Contacts: 4 Contact Size: 2.5mm
Sealing: IP67 Salt Spray: 48h

Dimensions Backshell

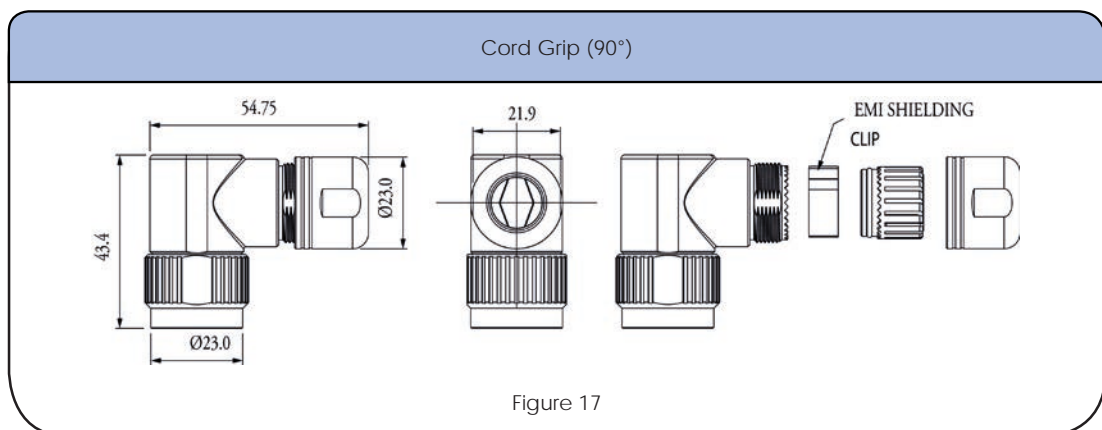
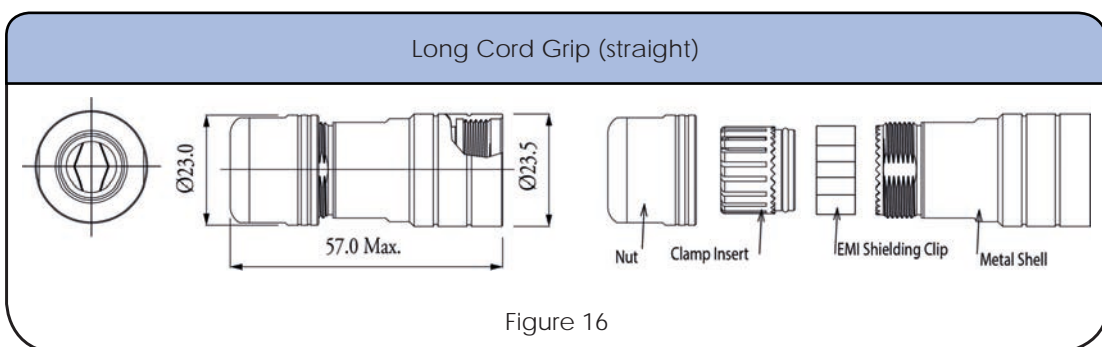
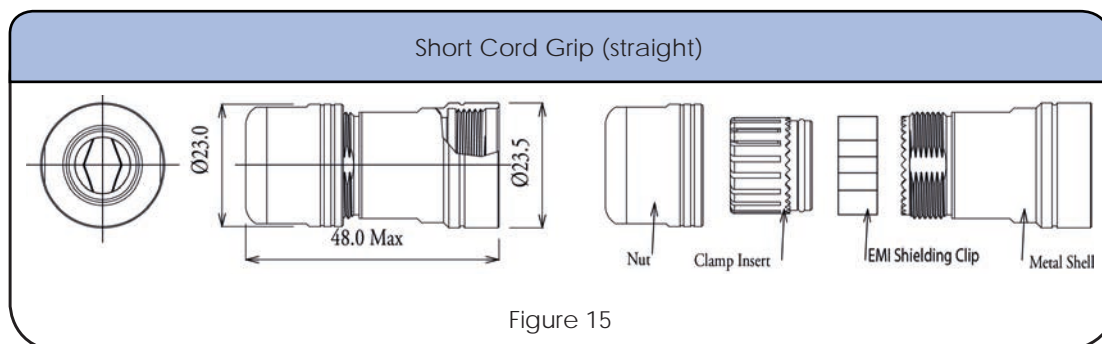

Shell Size: 14
Sealing: IP67

Number of Contacts: 4
Salt Spray: 48h

Contact Size: 2.5mm

Contacts



Crimp Contacts, Stamped & Formed

Part Number		AWG	Wire Range (mm ²)	Plating
Male	Female			
SP12A1T	SS12A1T	14-12	2.5-3.5	Tin









No machined contacts are available for this group

Tools



Shell Size: 14 Number of Contacts: 4 Contact Size: 2.5mm
Sealing: IP67 Salt Spray: 48h

Accessories

<p>Plug Dustcap with Chain</p>  <p>RT614DCG</p>	<p>Plug Dustcap without Chain</p>  <p>RT614DC</p>	<p>Receptacle Dustcap with Chain</p>  <p>RT014DCG</p>
<p>Receptacle Dustcap with Nylon Cord, Made of Rubber</p>  <p>RT014RL</p>	<p>Receptacle Dustcap without Chain</p>  <p>RT014DC</p>	<p>Receptacle Dustcap without Nylon Cord, Rubber Material</p>  <p>RB00011914</p>
<p>Sealing Plug</p>  <p>CA401259</p>	<p>Square Flange Receptacle Gaskets, Thickness 0.8mm (± 0.2)</p>  <p>RTFD14B</p>	<p>Locking Clip with Lanyard</p>  <p>108039114</p> <p>NEW! See Page 16</p>

STEP 1
Choose Receptacle Style

STEP 2
Choose Plug Style

STEP 2
Choose Backshell Style

Jam Nut Receptacles



OR
Square Flange Receptacles



Backshell



Plug



SEE TABLE ON NEXT PAGE FOR PART DETAILS

CONTACTS SOLD SEPARATELY SEE PAGE 68

Shell Size: 16 Number of Contacts: 4 Contact Size: 3.6mm
Sealing: IP67 Salt Spray: 48h

eco | mate[®] rm Standard Products

- Suitable For Indoor and Outdoor Applications
- EMI/RMI Shielding Capability with Appropriate Backshell
- Operating Temperature: -40°C to +105°C
- 500 Mating Cycles
- Contacts and Cord Grips Ordered Separately
- UL ECBT2 Certified*

An upgraded silicone seal is available for all connector parts. Please add "03" to the end of the part number when ordering. Operating Temperature: -40°C to +125°C. Not available in kits.

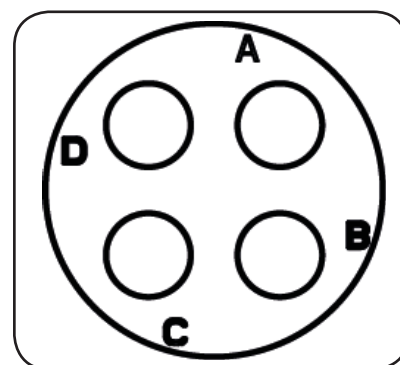

Insert Arrangement
Pin (Male) Faceview

Connector Part Numbers

Part Number		Connector Type	Figure Drawings	
Male	Female		Male	Female
RT07164PNH	RT07164SNH	Jam Nut Receptacle	1,5	2,5
RT07164PNHEC	RT07164SNHEC	Jam Nut Receptacle with O-ring Seal and End Cap with Individual Rear Wire Seal**	3,5	4,5
RT06164PNH	RT06164SNH	Plug	6	7
RT06164PNHEC	RT06164SNHEC	Plug with O-ring Seal and End Cap with Individual Rear Wire Seal**	8	9
RT00164PNH	RT00164SNH	Square Flange Receptacle	10,14	11,14
RT00164PNHEC	RT00164SNHEC	Square Flange Receptacle with O-ring Seal and End Cap with Individual Rear Wire Seal**	12,14	13,14

Contacts supplied separately see page 68

**See page 65 for the real seal wire range

Backshells

Part Number	Backshell Type	Cable Range (mm)	Figure Drawings	Shielding
RT0S16CGNS1	Short Cord Grip (straight)	9.0-14.5	15	✓
RT0S16CGNS2	Short Cord Grip (straight)	13.5-17	15	✓
RT0L16CGNS1	Long Cord Grip (straight)	9.0-14.5	16	✓
RT0L16CGNS2	Long Cord Grip (straight)	13.5-17	16	✓
RT0B16CGNS1	Cord Grip (90°)	9.5-14.5	17	✓
RT0B16CGNS2	Cord Grip (90°)	13.5-17.0	17	✓

*Connector parts with part numbers ending in EC (with an end cap) were not available for submittal at the time of UL certification.

Shell Size: 16 Number of Contacts: 4
 Sealing: IP67 Salt Spray: 48h

Contact Size: 3.6mm

Dimensions Jam Nut Receptacle

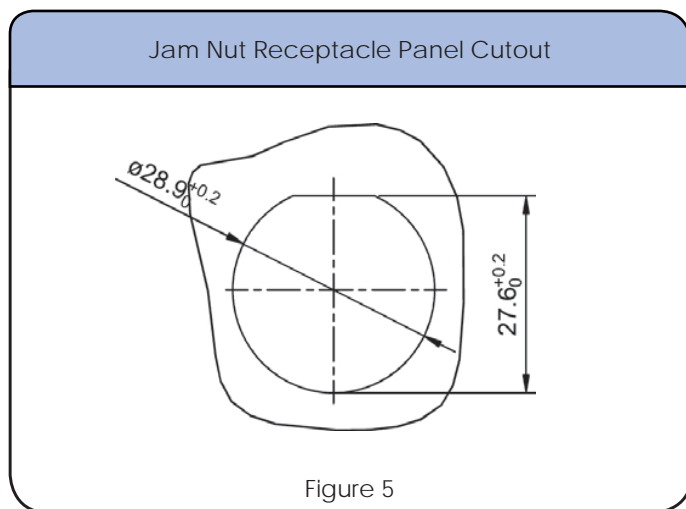
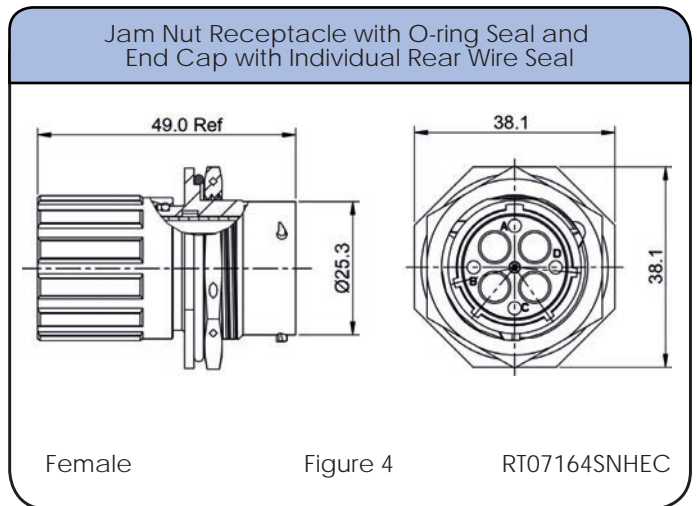
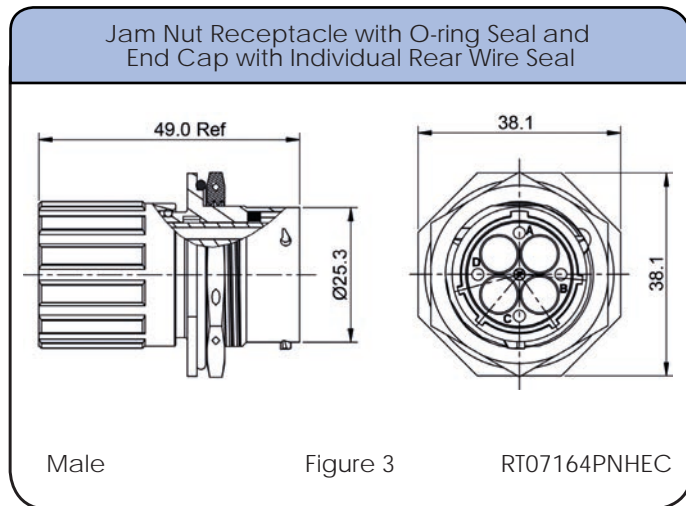
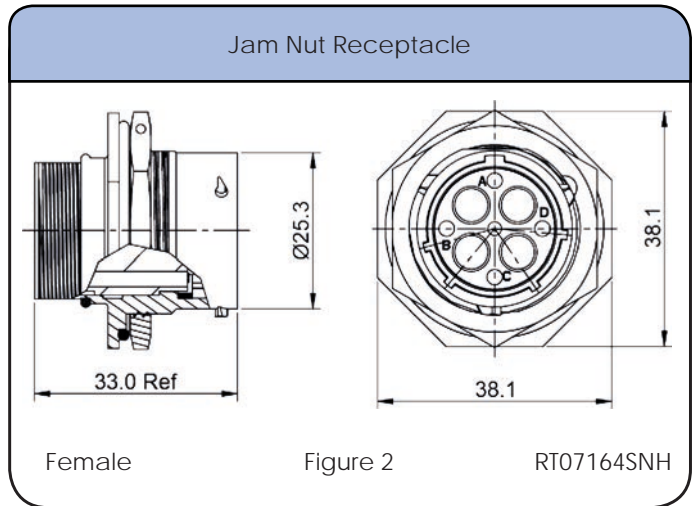
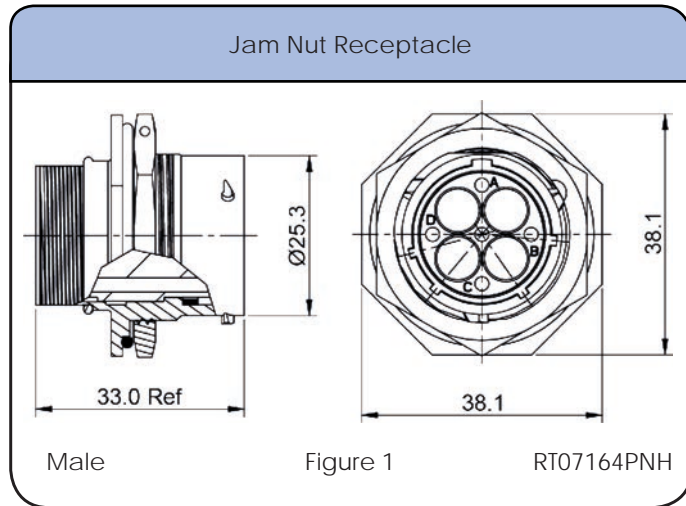

Shell Size: 16 Number of Contacts: 4
Sealing: IP67 Salt Spray: 48h

Contact Size: 3.6mm

Dimensions Plug

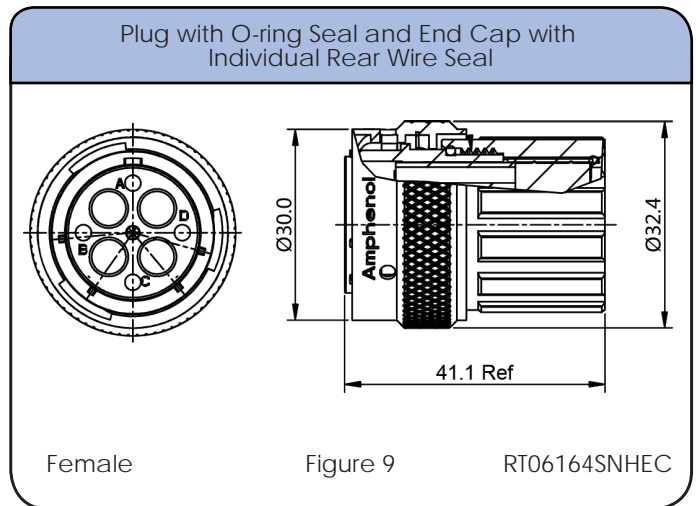
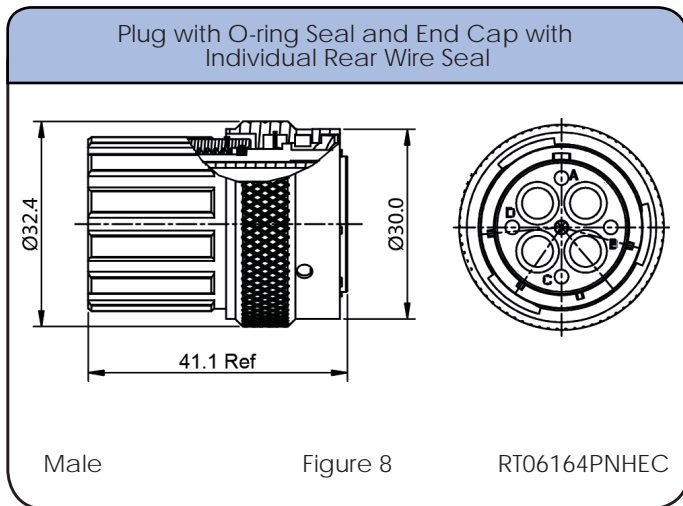
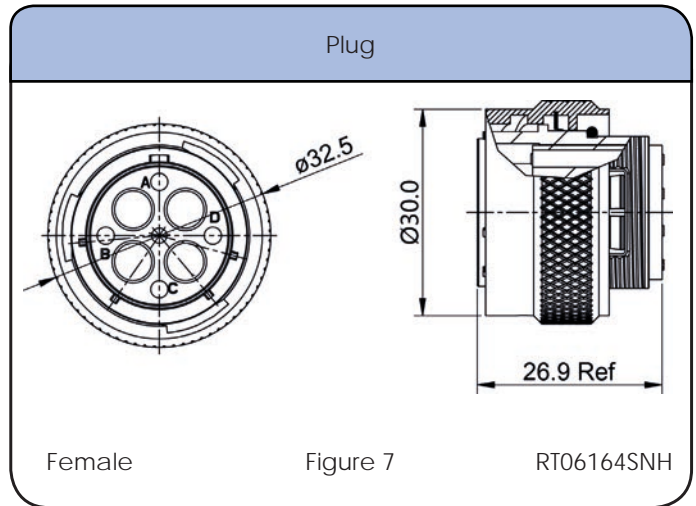
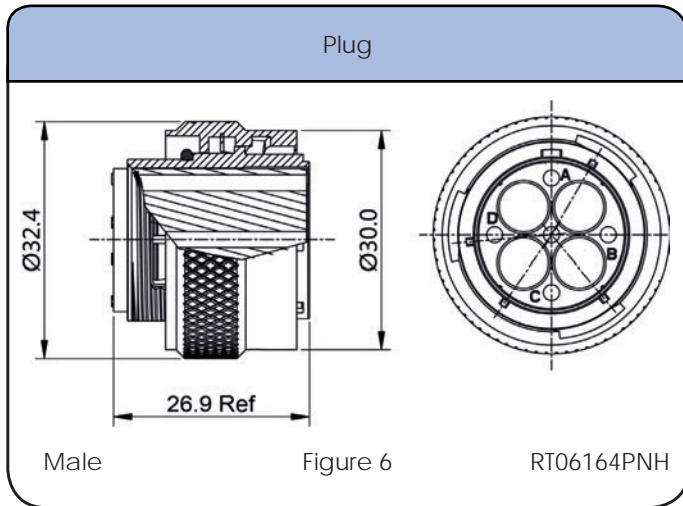

Individual Sealing Wire Range

Contact Size	Insulation Overall Diameter (min-max)	Wire Range
3.6mm	Ø2.8mm - Ø5.8mm	12 - 10 AWG

Shell Size: 16 Number of Contacts: 4 Contact Size: 3.6mm
 Sealing: IP67 Salt Spray: 48h

Dimensions Square Flange Receptacle

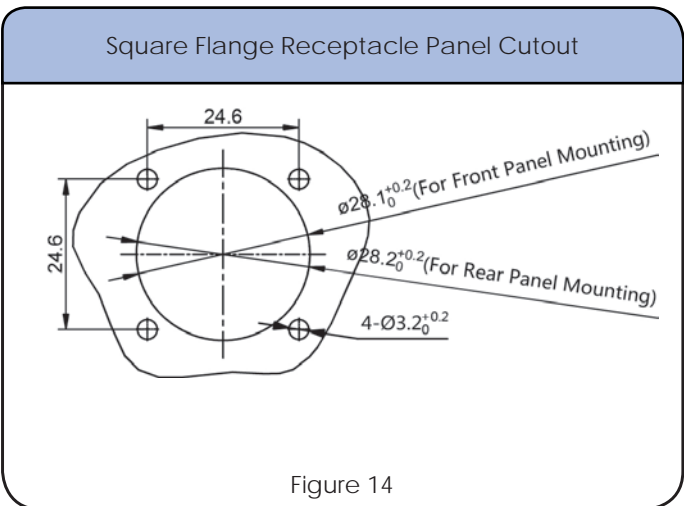
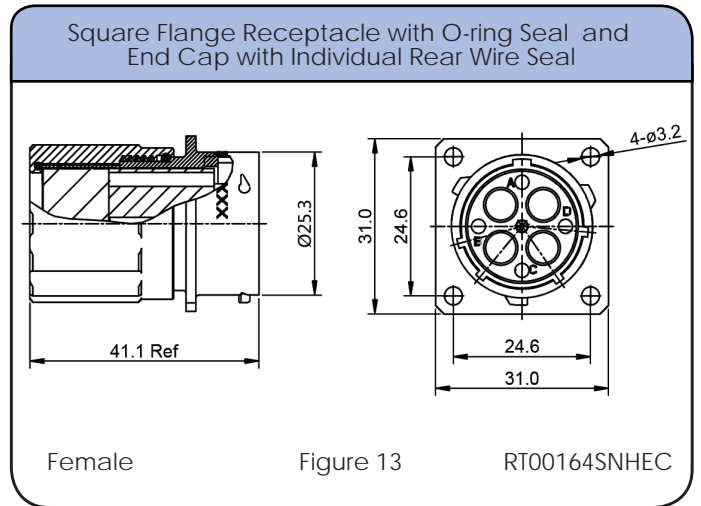
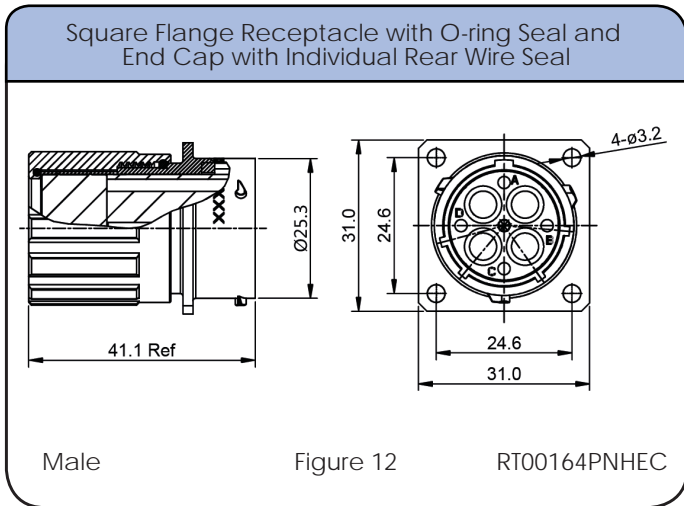
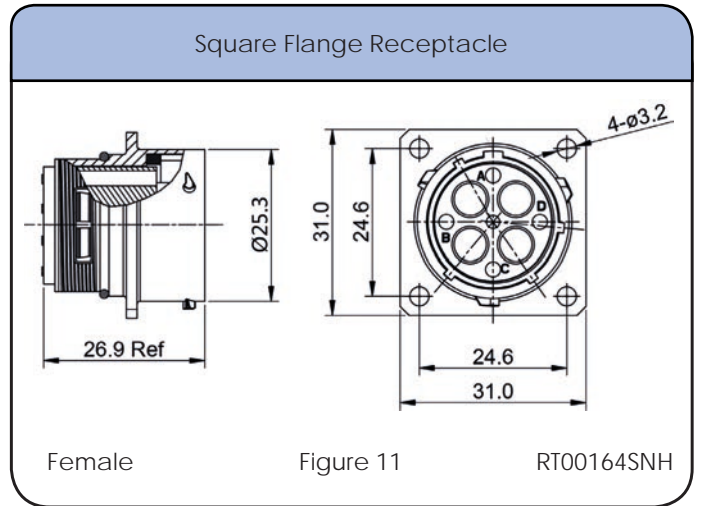
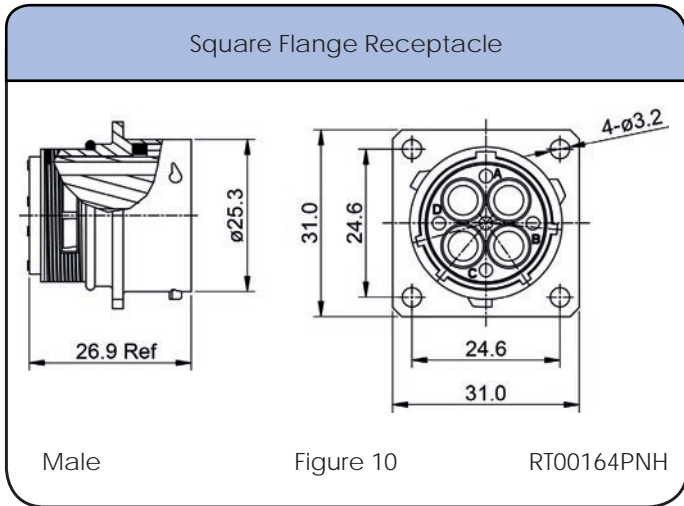

Shell Size: 16 Number of Contacts: 4 Contact Size: 3.6mm
Sealing: IP67 Salt Spray: 48h

Dimensions Backshell

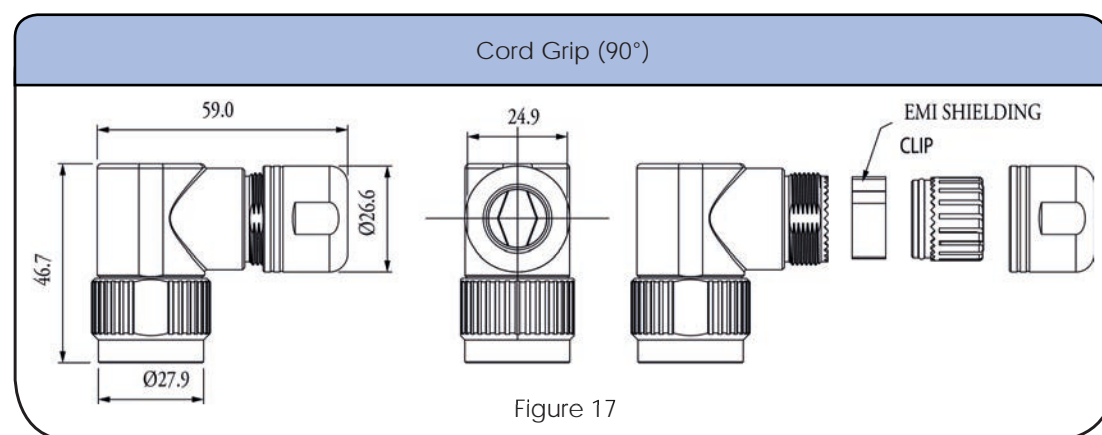
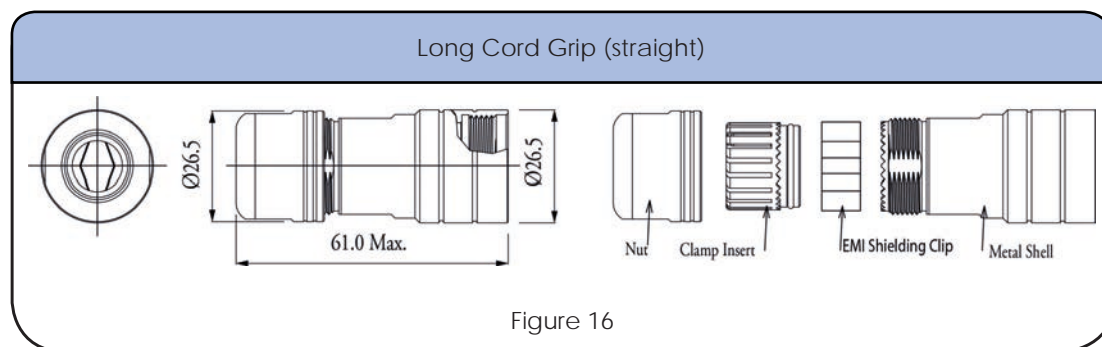
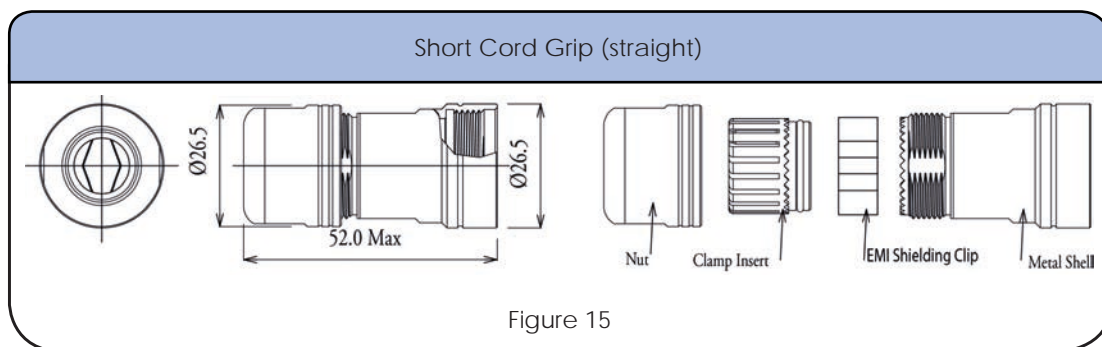

Shell Size: 16
Sealing: IP67

Number of Contacts: 4
Salt Spray: 48h

Contact Size: 3.6mm

Contacts

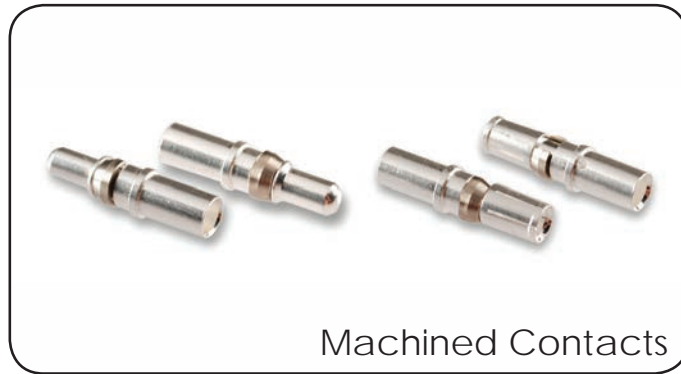

Crimp Contacts, Machined

Part Number		AWG	Wire Range (mm ²)	Plating
Male	Female			
MP10A23S	MS10A23S	8	3.0-6.0	Silver Plated

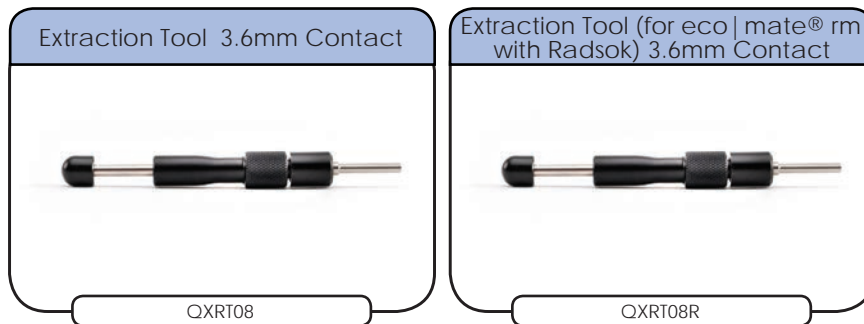

no stamped & formed contacts are available for this group

Tools



Shell Size: 16 Number of Contacts: 4 Contact Size: 3.6mm
Sealing: IP67 Salt Spray: 48h

Accessories

<p>Plug Dustcap with Chain</p>  <p>RT616DCG</p>	<p>Plug Dustcap without Chain</p>  <p>RT616DC</p>	<p>Receptacle Dustcap with Chain</p>  <p>RT016DCG</p>
<p>Receptacle Dustcap with Nylon Cord, Made of Rubber</p>  <p>RT016RL</p>	<p>Receptacle Dustcap without Chain</p>  <p>RT016DC</p>	<p>Receptacle Dustcap without Nylon Cord, Rubber Material</p>  <p>RB00011916</p>
<p>Square Flange Receptacle Gaskets, Thickness 0.8mm (±0.2)</p>  <p>RTFD16B</p>	<p>Locking Clip with Lanyard</p>  <p>108039116</p>	<p>NEW! See Page 16</p>

STEP 1
Choose Receptacle Style

STEP 2
Choose Plug Style

STEP 2
Choose Backshell Style

Jam Nut Receptacles



Jam Nut Receptacle Kit Including Receptacle & Contacts



OR
Square Flange Receptacles



Square Flange Receptacle Kit Including Receptacle, Gasket & Contacts



Plug



Backshell



OR
Plug Kit Including Connector, Backshell & Contacts



SEE TABLE ON NEXT PAGE FOR PART DETAILS

CONTACTS SOLD SEPARATELY SEE PAGE 76

Shell Size: 10 Number of Contacts: 6 Contact Size: 20
Sealing: IP67 Salt Spray: 48h

eco | mate[®] rm Standard Products

- Suitable For Indoor and Outdoor Applications
- EMI/RMI Shielding Capability with Appropriate Backshell
- Operating Temperature: -40°C to +105°C
- 500 Mating Cycles
- Contacts and Cord Grips Ordered Separately
- UL ECBT2 Certified*

An upgraded silicone seal is available for all connector parts. Please add "03" to the end of the part number when ordering. Operating Temperature: -40°C to +125°C. Not available in kits.

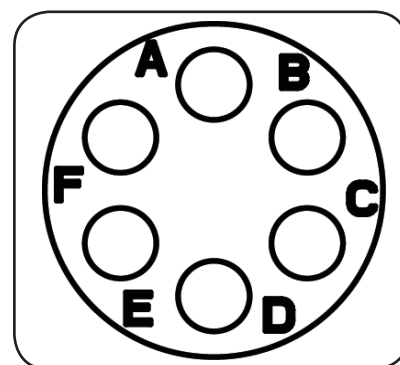

Insert Arrangement
Pin (Male) Faceview

Connector Part Numbers

Part Number		Connector Type	Figure Drawings	
Male	Female		Male	Female
RTOW7106PNH	RTOW7106SNH	Jam Nut Receptacle	1,5	2,5
RTOW7106PNHEC	RTOW7106SNHEC	Jam Nut Receptacle with O-ring Seal and End Cap with Individual Rear Wire Seal**	3,5	4,5
RTOW7106PNHK	RTOW7106SNHK	Jam Nut Receptacle Kit	1,5	2,5
RTOW6106PNH	RTOW6106SNH	Plug	6	7
RTOW6106PNHEC	RTOW6106SNHEC	Plug with O-ring Seal and End Cap with Individual Rear Wire Seal**	8	9
RTOW6106PNHK	RTOW6106SNHK	Plug Kit	6	7
RTOW0106PNH	RTOW0106SNH	Square Flange Receptacle	10,14	11,14
RTOW0106PNHEC	RTOW0106SNHEC	Square Flange Receptacle with O-ring Seal and End Cap with Individual Rear Wire Seal**	12,14	13,14
RTOW0106PNHK	RTOW0106SNHK	Square Flange Receptacle Kit	10,14	11,14

Contacts supplied separately see page 76

**See page 73 for the real seal wire range

Backshells

Part Number	Backshell Type	Cable Range (mm)	Figure Drawings	Shielding
RT0S10CGNS1	Short Cord Grip (straight)	3-6.5	15	✓
RT0S10CGNS2	Short Cord Grip (straight)	5-8.5	15	✓
RT0L10CGNS1	Long Cord Grip (straight)	3-6.5	16	✓
RT0L10CGNS2	Long Cord Grip (straight)	5-8.5	16	✓

*Connector parts with part numbers ending in EC (with an end cap) were not available for submittal at the time of UL certification.

Shell Size: 10 Number of Contacts: 6
 Sealing: IP67 Salt Spray: 48h

Contact Size: 20

Dimensions Jam Nut Receptacle

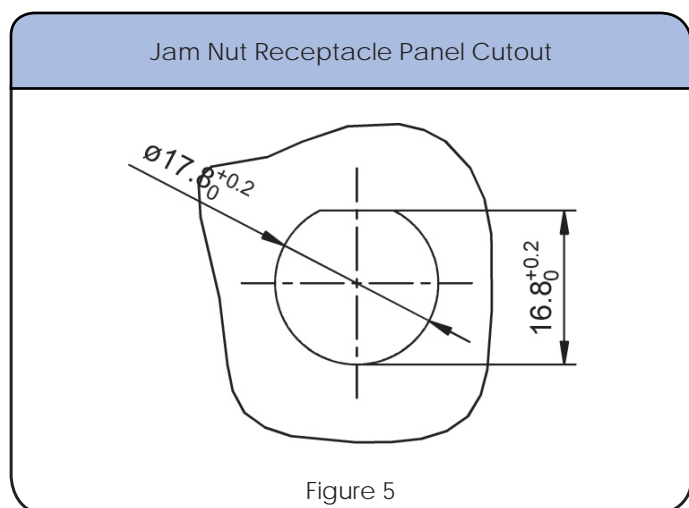
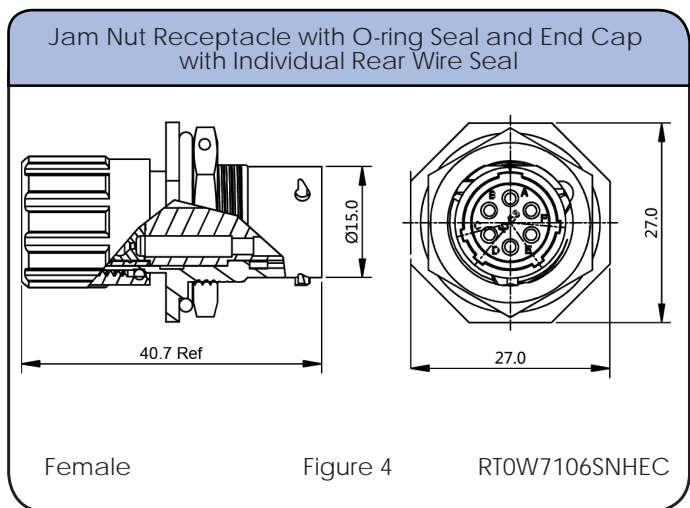
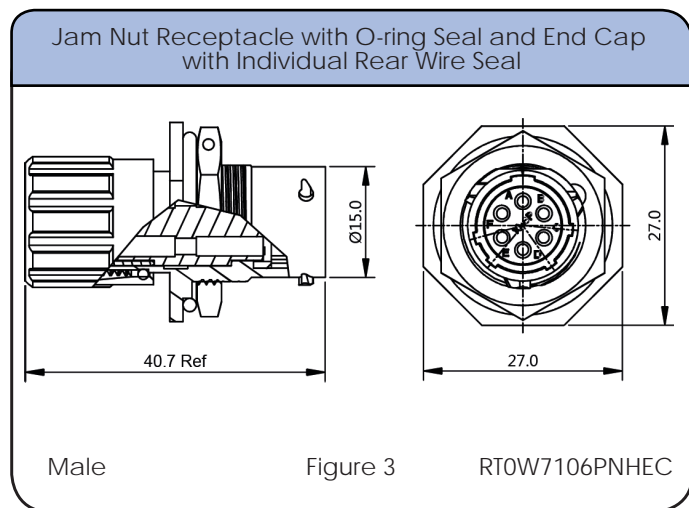
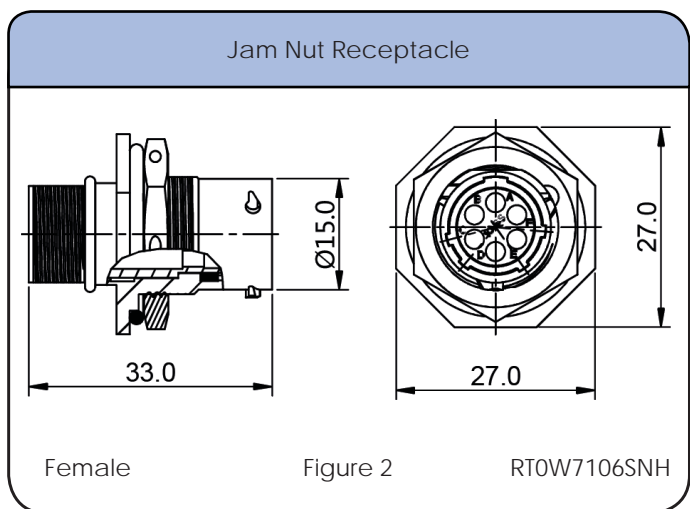
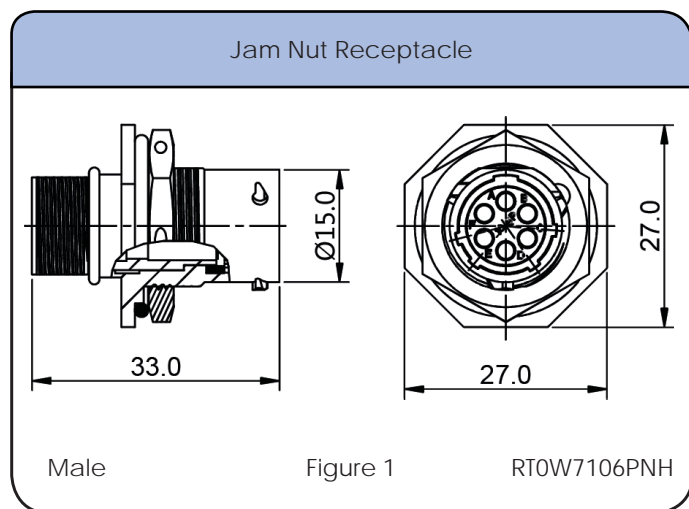

Shell Size: 10 Number of Contacts: 6 Contact Size: 20
Sealing: IP67 Salt Spray: 48h

Dimensions Plug

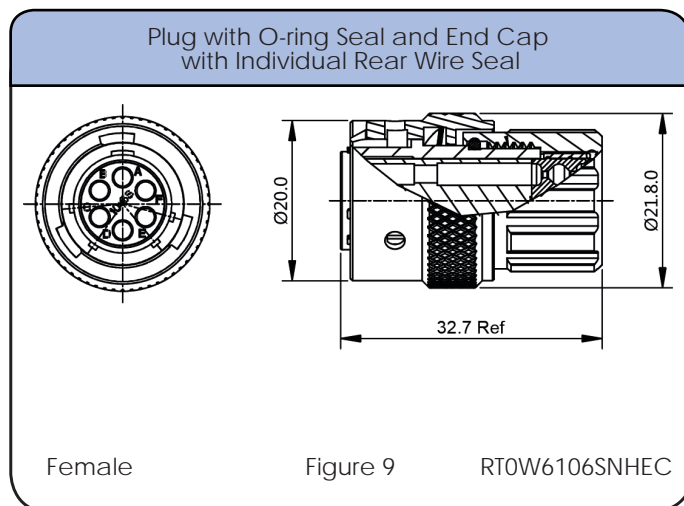
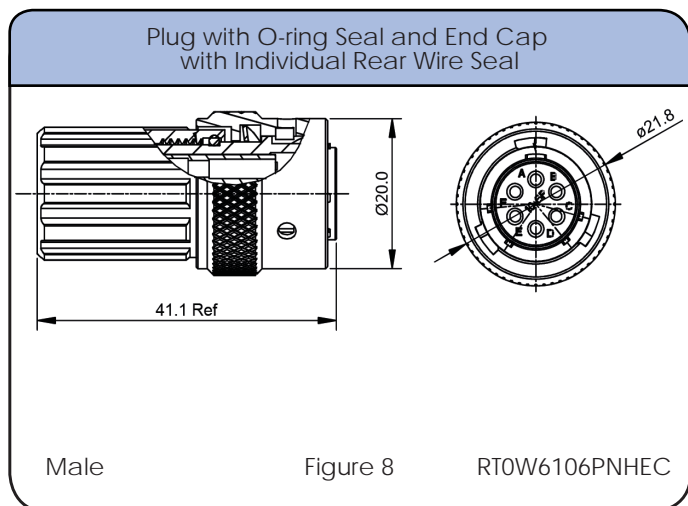
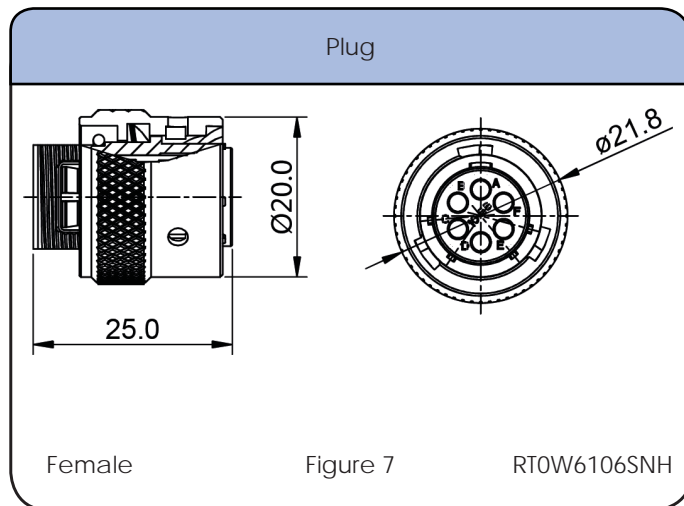
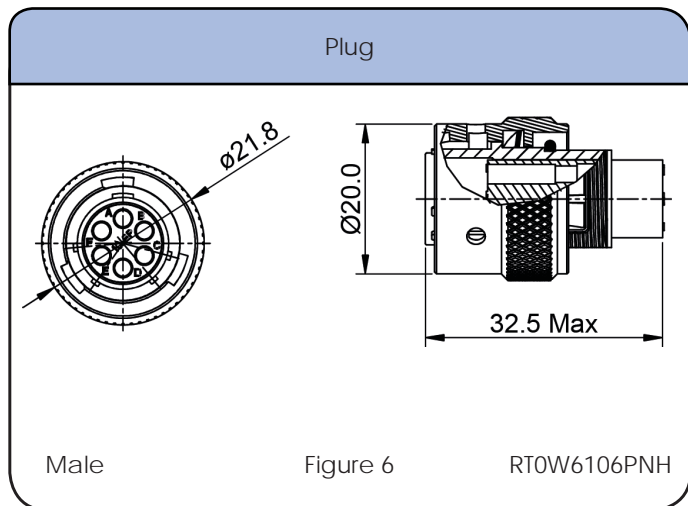

Individual Sealing Wire Range

Contact Size	Insulation Overall Diameter (min-max)	Wire Range
20	Ø1.6mm - Ø2.6mm	20 - 30 AWG

Shell Size: 10 Number of Contacts: 6 Contact Size: 20
 Sealing: IP67 Salt Spray: 48h

Dimensions Square Flange Receptacle

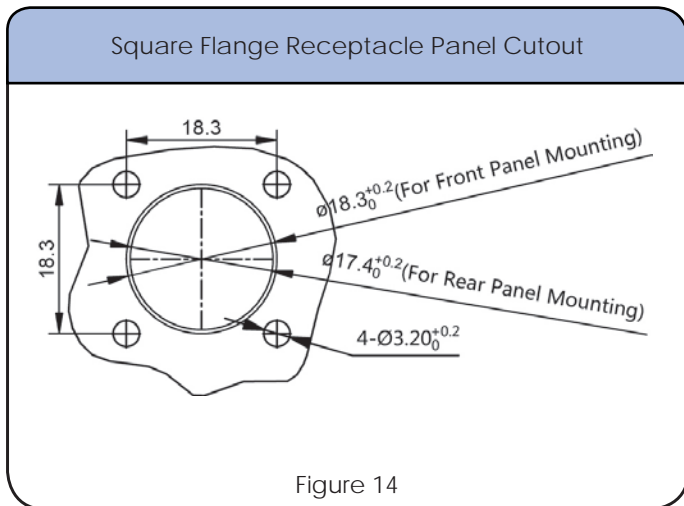
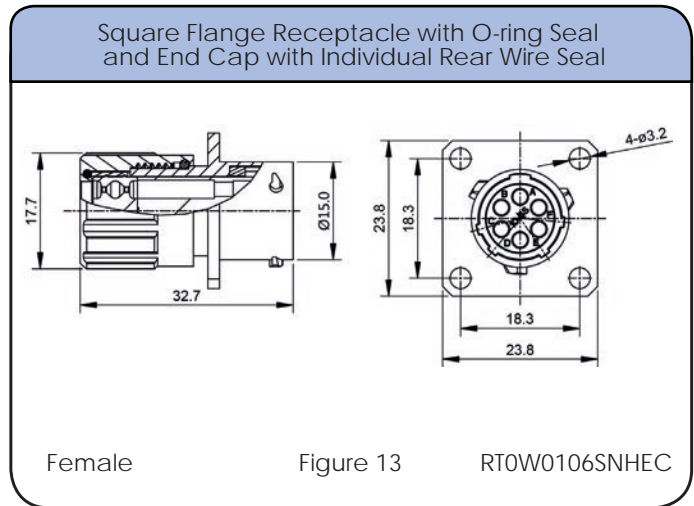
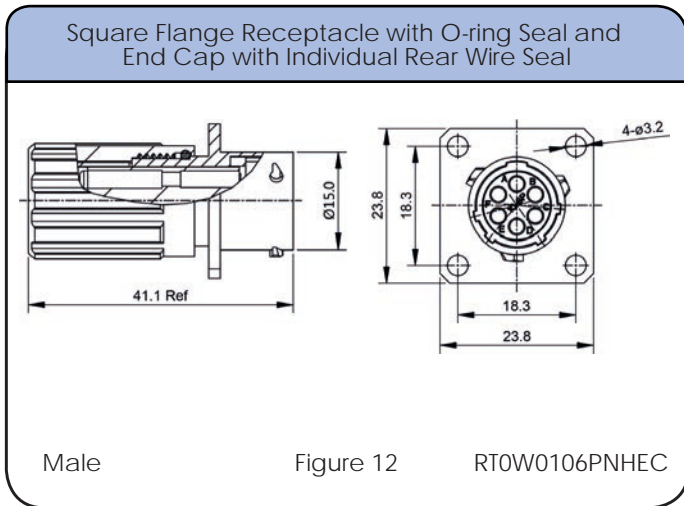
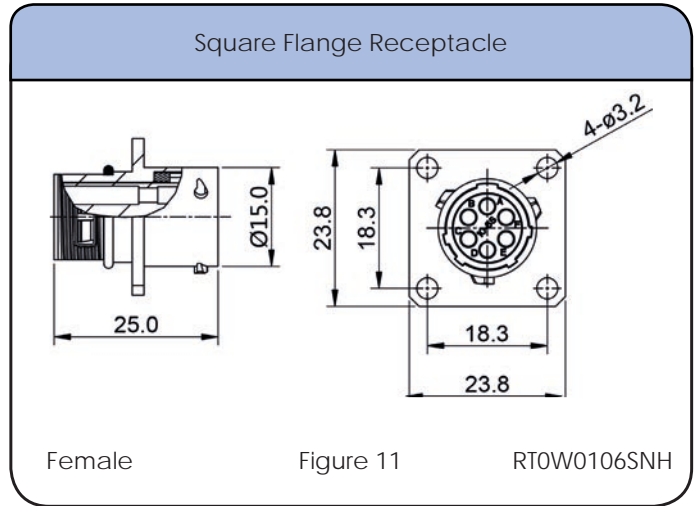
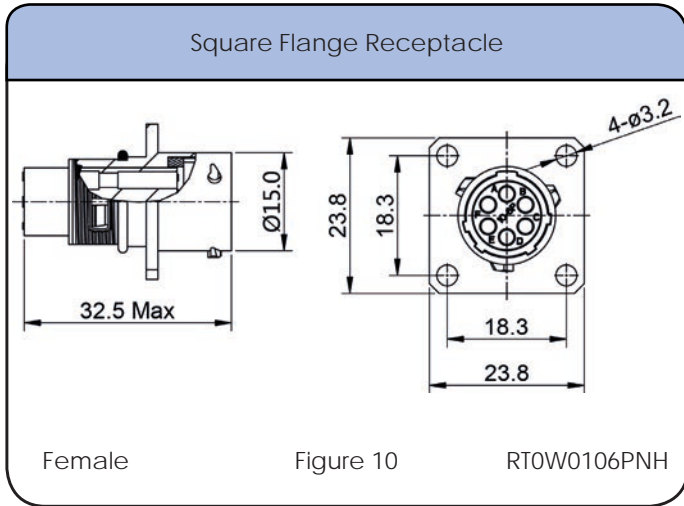

Shell Size: 10 Number of Contacts: 6 Contact Size: 20
Sealing: IP67 Salt Spray: 48h

Dimensions Backshell

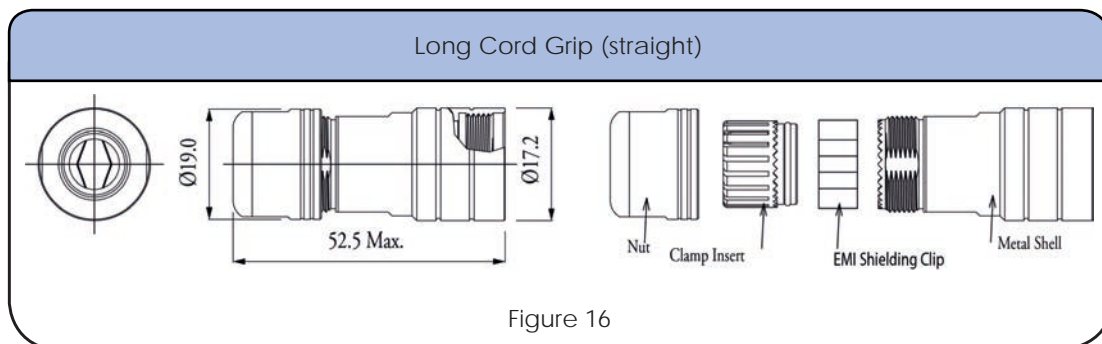
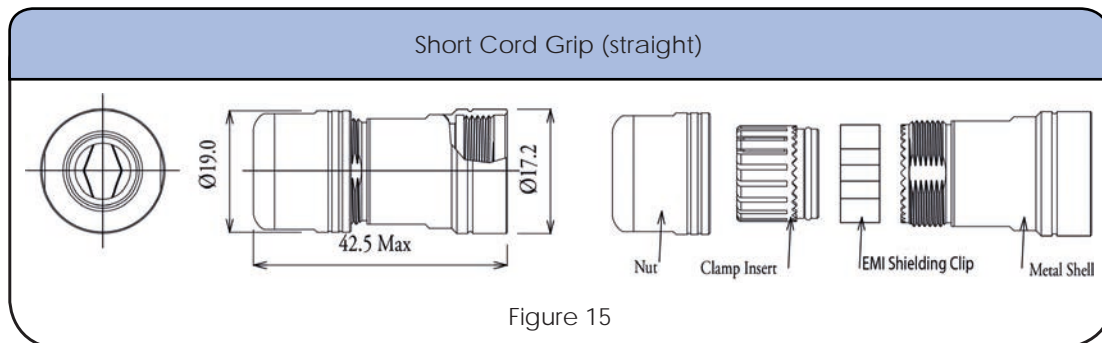

Accessories

<p>Locking Clip with Lanyard</p> <p>108039110</p>	<p>Plug Dustcap with Chain</p> <p>RT610DCG</p>	<p>Plug Dustcap without Chain</p> <p>RT610DC</p>	<p>Receptacle Dustcap with Chain</p> <p>RT010DCG</p>
<p>Receptacle Dustcap without Chain</p> <p>RT010DC</p>	<p>Receptacle Dustcap with Nylon Cord, Made of Rubber</p> <p>RT010RL</p>	<p>Receptacle Dustcap without Nylon Cord, Rubber Material</p> <p>RB00011910</p>	<p>Sealing Plug</p> <p>CA402059</p>
<p>Square Flange Receptacle Gaskets, Thickness 0.8mm (±0.2)</p> <p>RTFD10B</p>			

Shell Size: 10
Sealing: IP67

Number of Contacts: 6
Salt Spray: 48h

Contact Size: 20

Contacts



Crimp Contacts, Machined (7.5A)

Part Number		AWG	Wire Range (mm ²)	Plating
Male	Female			
MP20W23F	MS20W23F	22-20	.34-.50	Gold Flash
MP20W23G5	MS20W23G5	22-20	.34-.50	Gold 5μ"
MP20W23G10	MS20W23G10	22-20	.34-.50	Gold 10μ"
MP20W23G15	MS20W23G15	22-20	.34-.50	Gold 15μ"
MP20W23G30	MS20W23G30	22-20	.34-.50	Gold 30μ"
MP24W23F	MS24W23F	26-24	.13-.25	Gold Flash
MP24W23G5	MS24W23G5	26-24	.13-.25	Gold 5μ"
MP24W23G10	MS24W23G10	26-24	.13-.25	Gold 10μ"
MP24W23G15	MS24W23G15	26-24	.13-.25	Gold 15μ"
MP24W23G30	MS24W23G30	26-24	.13-.25	Gold 30μ"
MP28W23F	MS28W23F	30-28	.05-.08	Gold Flash
MP28W23G5	MS28W23G5	30-28	.05-.08	Gold 5μ"
MP28W23G10	MS28W23G10	30-28	.05-.08	Gold 10μ"
MP28W23G15	MS28W23G15	30-28	.05-.08	Gold 15μ"
MP28W23G30	MS28W23G30	30-28	.05-.08	Gold 30μ"

Tools



Shell Size: 10 Number of Contacts: 6 Contact Size: 20
Sealing: IP67 Salt Spray: 48h

Contacts (con't)



Crimp Contacts, Stamped & Formed (5A)

Part Number		AWG	Wire Range (mm ²)	Plating
Male	Female			
SP20W1F	SS20W1F	22-20	.34-.50	Gold Flash
SP20W1G5	SS20W1G5	22-20	.34-.50	Gold 5μ"
SP20W1G10	SS20W1G10	22-20	.34-.50	Gold 10μ"
SP20W1G15	SS20W1G15	22-20	.34-.50	Gold 15μ"
SP20W1G30	SS20W1G30	22-20	.34-.50	Gold 30μ"
SP24W1F	SS24W1F	26-24	.14-.25	Gold Flash
SP24W1G5	SS24W1G5	26-24	.14-.25	Gold 5μ"
SP24W1G10	SS24W1G10	26-24	.14-.25	Gold 10μ"
SP24W1G15	SS24W1G15	26-24	.14-.25	Gold 15μ"
SP24W1G30	SS24W1G30	26-24	.14-.25	Gold 30μ"
SP28W1F	SS28W1F	30-28	.05-.08	Gold Flash
SP28W1G5	SS28W1G5	30-28	.05-.08	Gold 5μ"
SP28W1G10	SS28W1G10	30-28	.05-.08	Gold 10μ"
SP28W1G15	SS28W1G15	30-28	.05-.08	Gold 15μ"
SP28W1G30	SS28W1G30	30-28	.05-.08	Gold 30μ"

Tools

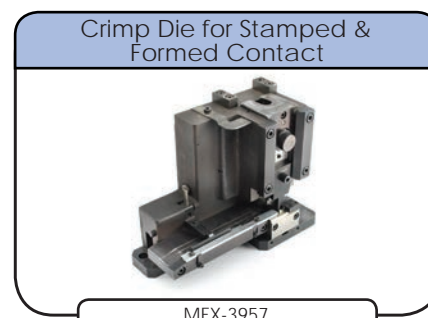

STEP 1
Choose Receptacle Style

STEP 2
Choose Plug Style

STEP 2
Choose Backshell Style

Jam Nut Receptacles



OR
Square Flange Receptacles



Jam Nut Receptacle Kit Including Receptacle & Contacts



Square Flange Receptacle Kit Including Receptacle, Gasket & Contacts



Plug



Backshell



OR
Plug Kit Including Connector, Backshell & Contacts



SEE TABLE ON NEXT PAGE FOR PART DETAILS

CONTACTS SOLD SEPARATELY SEE PAGE 84

Shell Size: 12 Number of Contacts: 8 Contact Size: 16
Sealing: IP67 Salt Spray: 48h

eco | mate[®] rm
Standard Products

- Suitable For Indoor and Outdoor Applications
- EMI/RMI Shielding Capability with Appropriate Backshell
- Operating Temperature: -40°C to +105°C
- 500 Mating Cycles
- Contacts and Cord Grips Ordered Separately
- UL ECBT2 Certified*

An upgraded silicone seal is available for all connector parts. Please add "03" to the end of the part number when ordering. Operating Temperature: -40°C to +125°C. Not available in kits.

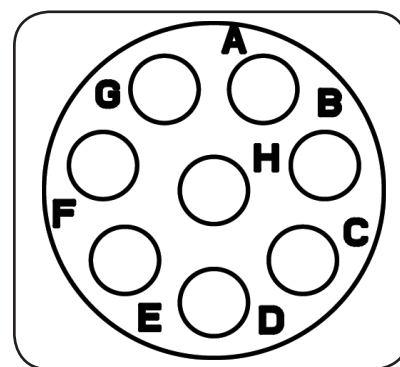

Insert Arrangement
Pin (Male) Faceview

Connector Part Numbers

Part Number		Connector Type	Figure Drawings	
Male	Female		Male	Female
RT07128PNH	RT07128SNH	Jam Nut Receptacle	1,5	2,5
RT07128PNHEC	RT07128SNHEC	Jam Nut Receptacle with O-ring Seal and End Cap with Individual Rear Wire Seal**	3,5	4,5
RT07128PNHK	RT07128SNHK	Jam Nut Receptacle Kit	1,5	2,5
RT06128PNH	RT06128SNH	Plug	6	7
RT06128PNHEC	RT06128SNHEC	Plug with O-ring Seal and End Cap with Individual Rear Wire Seal**	8	9
RT06128PNHK	RT06128SNHK	Plug Kit	6	7
RT00128PNH	RT00128SNH	Square Flange Receptacle	10	11,14
RT00128PNHEC	RT00128SNHEC	Square Flange Receptacle with O-ring Seal and End Cap with Individual Rear Wire Seal**	12,14	13,14
RT00128PNHK	RT00128SNHK	Square Flange Receptacle Kit	10,14	11,14

Contacts supplied separately see page 84

**See page 81 for the real seal wire range

Backshells

Part Number	Backshell Type	Cable Range (mm)	Figure Drawings	Shielding
RT0S12CGNS1	Short Cord Grip (straight)	6-10.5	15	✓
RT0S12CGNS2	Short Cord Grip (straight)	8.5-12.5	15	✓
RT0L12CGNS1	Long Cord Grip (straight)	6-10.5	16	✓
RT0L12CGNS2	Long Cord Grip (straight)	8.5-12.5	16	✓
RT0B12CGNS1	Cord Grip (90°)	6-10.5	17	✓
RT0B12CGNS2	Cord Grip (90°)	8.0-12.5	17	✓

*Connector parts with part numbers ending in EC (with an end cap) were not available for submittal at the time of UL certification.

Shell Size: 12 Number of Contacts: 8
 Sealing: IP67 Salt Spray: 48h

Contact Size: 16

Dimensions Jam Nut Receptacle

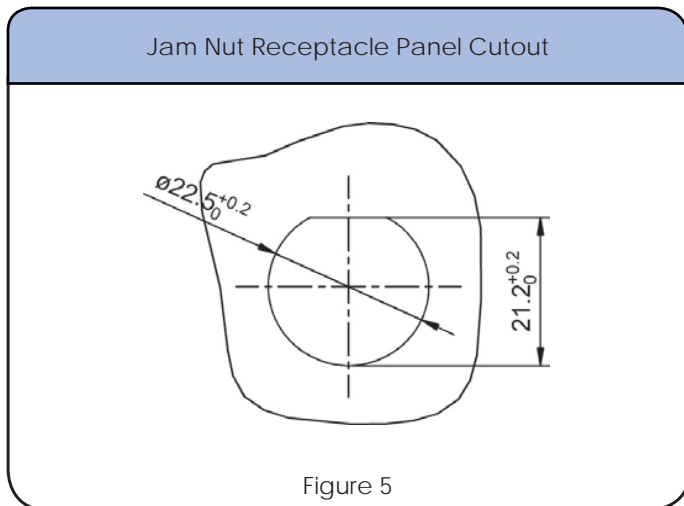
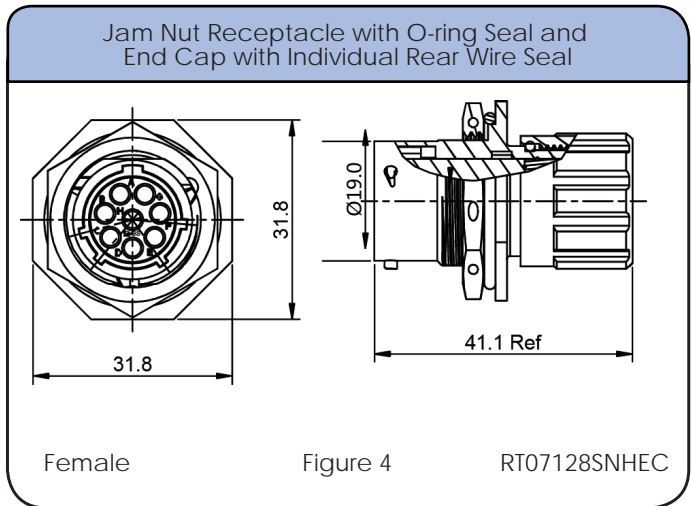
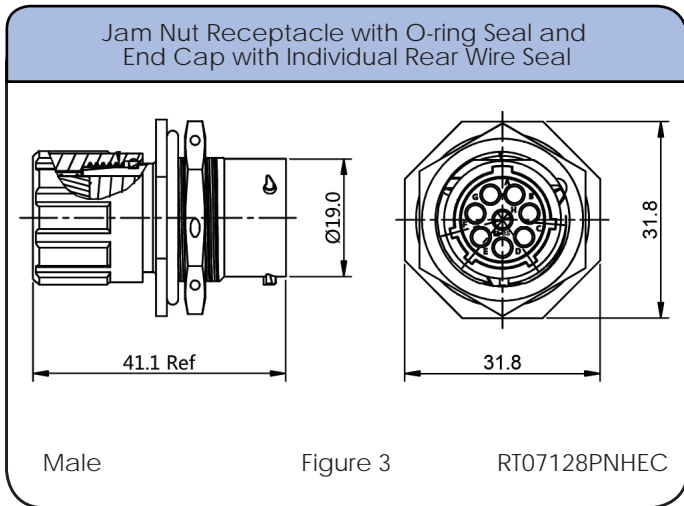
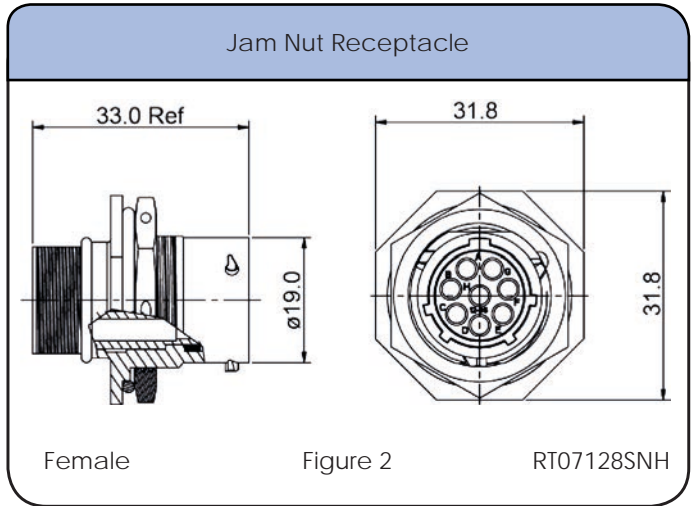
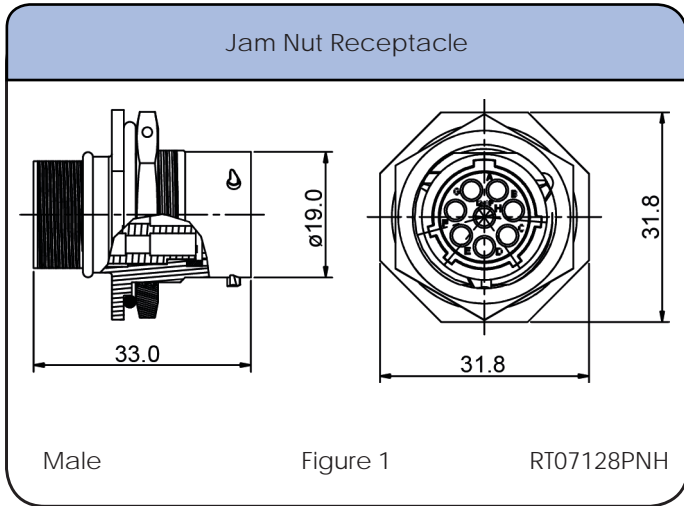

Shell Size: 12 Number of Contacts: 8 Contact Size: 16
Sealing: IP67 Salt Spray: 48h

Dimensions Plug

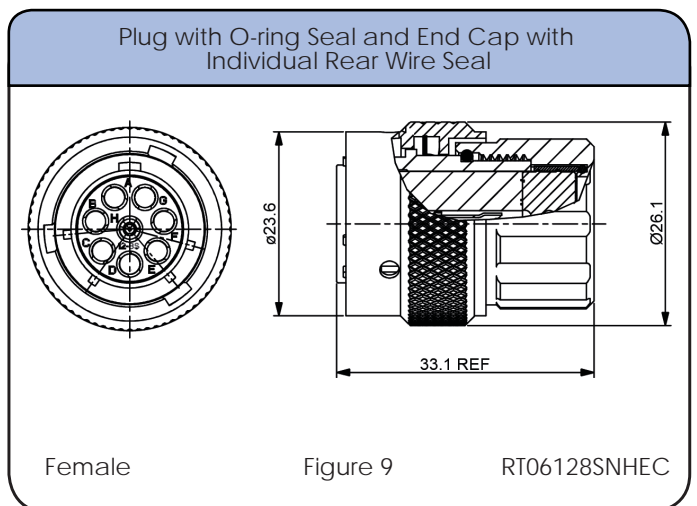
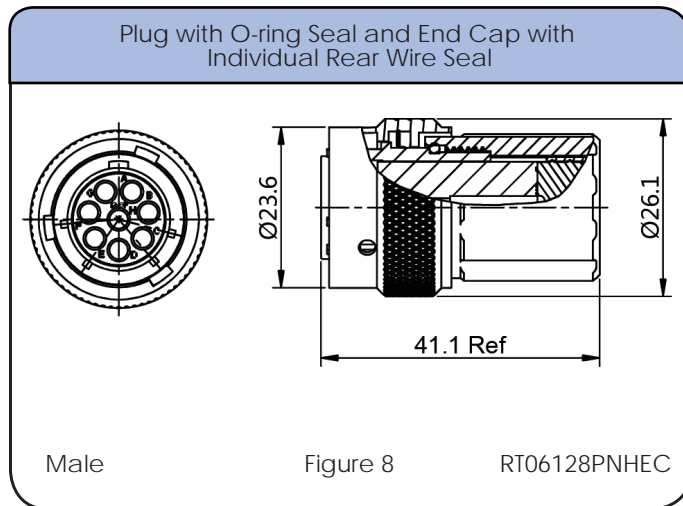
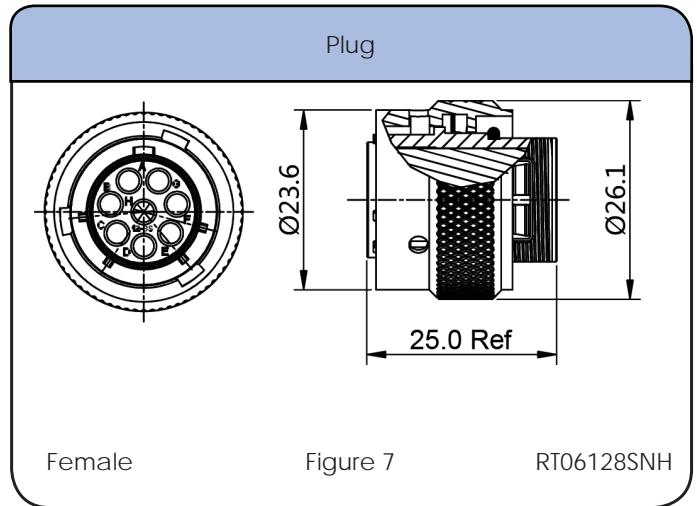
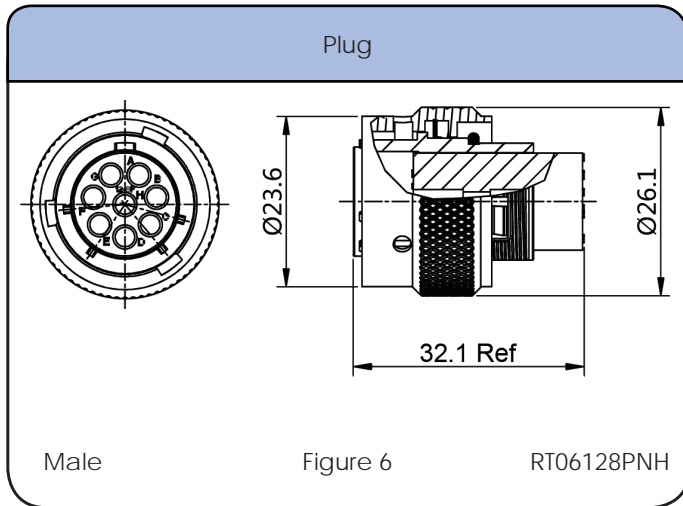

Individual Sealing Wire Range

Contact Size	Insulation Overall Diameter (min-max)	Wire Range
16	Ø2.0mm - Ø3.2mm	14 - 24 AWG

Shell Size: 12 Number of Contacts: 8 Contact Size: 16
 Sealing: IP67 Salt Spray: 48h

Dimensions Square Flange Receptacle

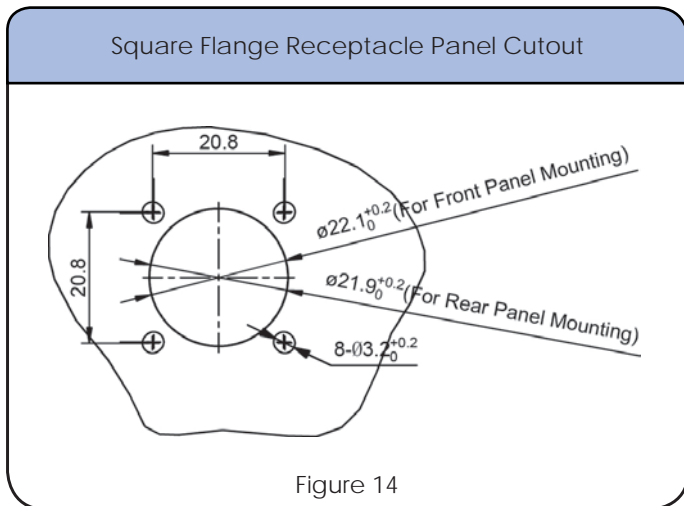
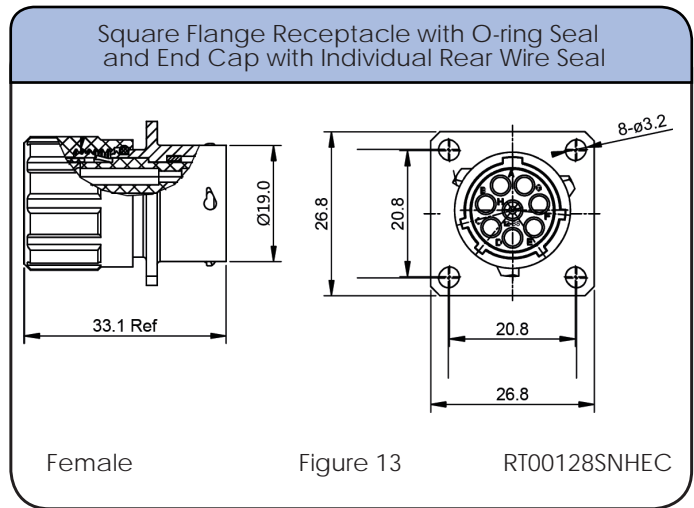
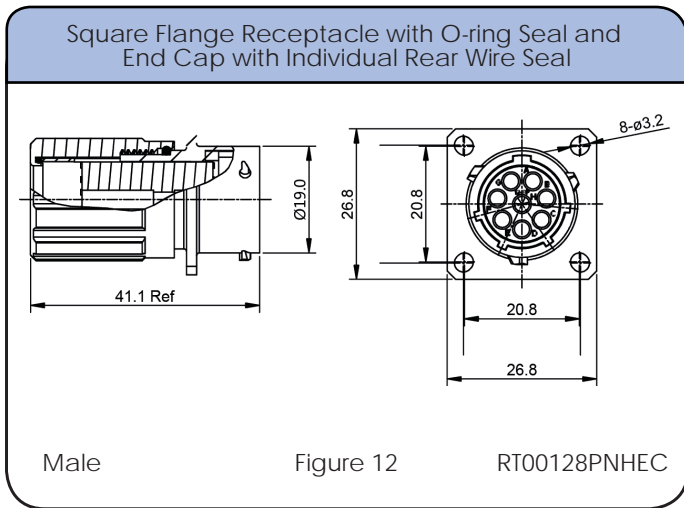
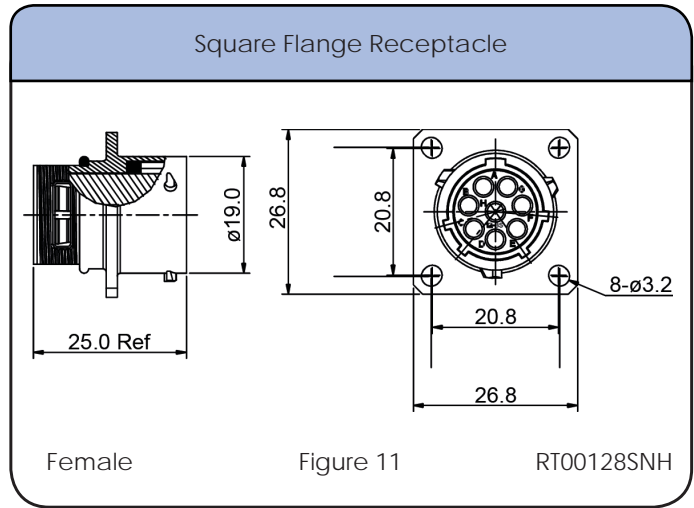
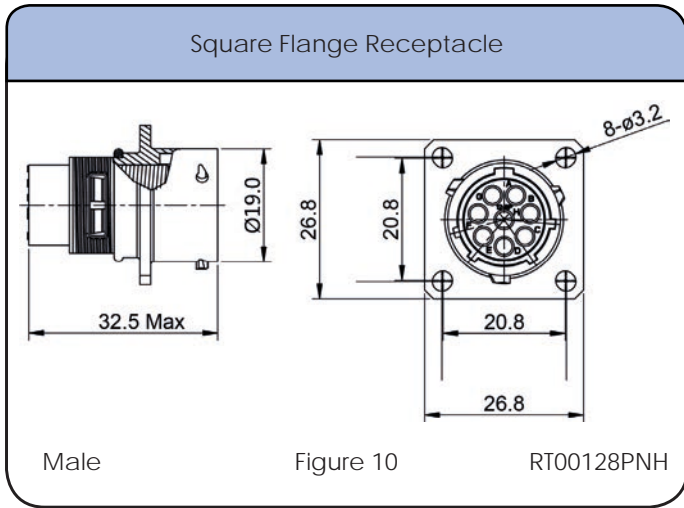

Shell Size: 12 Number of Contacts: 8 Contact Size: 16
Sealing: IP67 Salt Spray: 48h

Dimensions Backshell

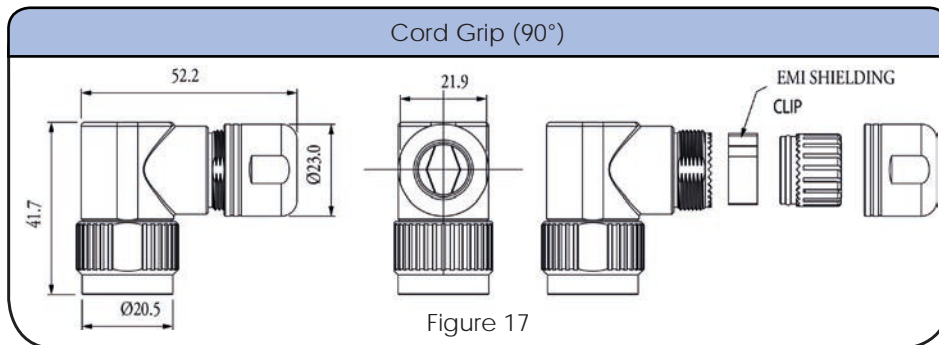
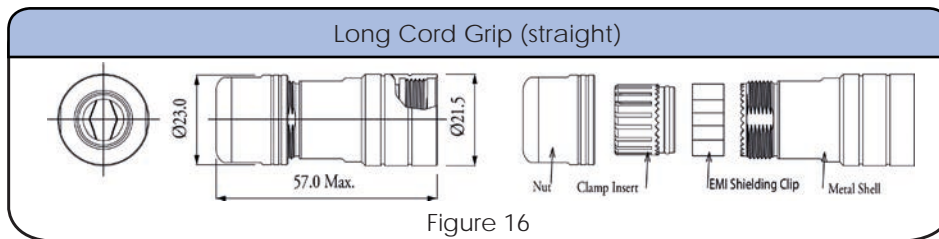
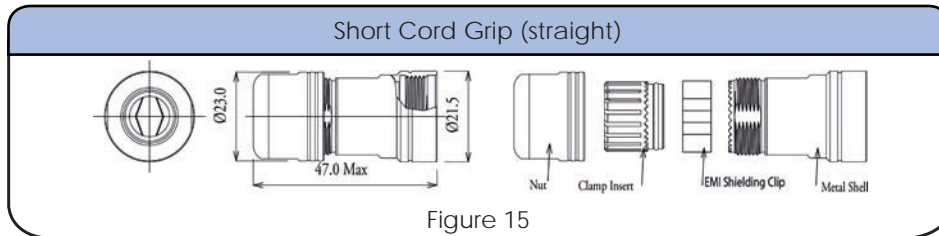

Accessories

<p>Locking Clip with Lanyard</p> <p>108039112</p>	<p>Plug Dustcap with Chain</p> <p>RT612DCG</p>	<p>Plug Dustcap without Chain</p> <p>RT612DC</p>	<p>Receptacle Dustcap with Chain</p> <p>RT012DCG</p>
<p>Receptacle Dustcap with Nylon Cord, Made of Rubber</p> <p>RT012RL</p>	<p>Receptacle Dustcap without Chain</p> <p>RT012DC</p>	<p>Receptacle Dustcap without Nylon Cord, Rubber Material</p> <p>RB00011912</p>	<p>Sealing Plug</p> <p>CA401659</p>
<p>Square Flange Receptacle Gaskets, Thickness 0.8mm (±0.2)</p> <p>RTFD12B</p>			

NEW!
see
Page
16

Shell Size: 12 Number of Contacts: 8 Contact Size: 16
 Sealing: IP67 Salt Spray: 48h

Contacts



Crimp Contacts, Machined

Part Number		AWG	Wire Range (mm ²)	Plating
Male	Female			
MP14M23F	MS14M23F	14	2.0-2.5	Gold Flash
MP14M23G5	MS14M23G5	14	2.0-2.5	Gold 5μ"
MP14M23G10	MS14M23G10	14	2.0-2.5	Gold 10μ"
MP14M23G15	MS14M23G15	14	2.0-2.5	Gold 15μ"
MP14M23G30	MS14M23G30	14	2.0-2.5	Gold 30μ"
MP16M23F	MS16M23F	18-16	.75-1.5	Gold Flash
MP16M23G5	MS16M23G5	18-16	.75-1.5	Gold 5μ"
MP16M23G10	MS16M23G10	18-16	.75-1.5	Gold 10μ"
MP16M23G15	MS16M23G15	18-16	.75-1.5	Gold 15μ"
MP16M23G30	MS16M23G30	18-16	.75-1.5	Gold 30μ"
MP20M23F	MS20M23F	22-20	.34-.50	Gold Flash
MP20M23G5	MS20M23G5	22-20	.34-.50	Gold 5μ"
MP20M23G10	MS20M23G10	22-20	.34-.50	Gold 10μ"
MP20M23G15	MS20M23G15	22-20	.34-.50	Gold 15μ"
MP20M23G30	MS20M23G30	22-20	.34-.50	Gold 30μ"
MP24M23F	MS24M23F	26-24	.14-.25	Gold Flash
MP24M23G5	MS24M23G5	26-24	.14-.25	Gold 5μ"
MP24M23G10	MS24M23G10	26-24	.14-.25	Gold 10μ"
MP24M23G15	MS24M23G15	26-24	.14-.25	Gold 15μ"
MP24M23G30	MS24M23G30	26-24	.14-.25	Gold 30μ"

Tools



Shell Size: 12 Number of Contacts: 8 Contact Size: 16
Sealing: IP67 Salt Spray: 48h

Contacts (con't)



Stamped & Formed Contacts

Crimp Contacts, Stamped & Formed

Part Number		AWG	Wire Range (mm ²)	Plating
Male	Female			
SP14M1F	SS14M1F	14	2.0-2.5	Gold Flash
SP14M1G5	SS14M1G5	14	2.0-2.5	Gold 5μ"
SP14M1G10	SS14M1G10	14	2.0-2.5	Gold 10μ"
SP14M1G15	SS14M1G15	14	2.0-2.5	Gold 15μ"
SP14M1G30	SS14M1G30	14	2.0-2.5	Gold 30μ"
SP16M1F	SS16M1F	18-16	.75-1.5	Gold Flash
SP16M1G5	SS16M1G5	18-16	.75-1.5	Gold 5μ"
SP16M1G10	SS16M1G10	18-16	.75-1.5	Gold 10μ"
SP16M1G15	SS16M1G15	18-16	.75-1.5	Gold 15μ"
SP16M1G30	SS16M1G30	18-16	.75-1.5	Gold 30μ"
SP20M1F	SS20M1F	22-20	.34-.50	Gold Flash
SP20M1G5	SS20M1G5	22-20	.34-.50	Gold 5μ"
SP20M1G10	SS20M1G10	22-20	.34-.50	Gold 10μ"
SP20M1G15	SS20M1G15	22-20	.34-.50	Gold 15μ"
SP20M1G30	SS20M1G30	22-20	.34-.50	Gold 30μ"
SP24M1F	SS24M1F	22-20	.14-.25	Gold Flash
SP24M1G5	SS24M1G5	26-24	.14-.25	Gold 5μ"
SP24M1G10	SS24M1G10	26-24	.14-.25	Gold 10μ"
SP24M1G15	SS24M1G15	26-24	.14-.25	Gold 15μ"
SP24M1G30	SS24M1G30	26-24	.14-.25	Gold 30μ"

Tools



Contact Extraction Tool, #16 (Ø 1.6) Contact

QXRT16



Hand Tool, Stamped & Formed Contact, Size 16, 20-14AWG

MFX-3954



Crimp Die for Stamped & Formed Contact

MFX-3957

STEP 1
Choose Receptacle Style

STEP 2
Choose Plug Style

STEP 2
Choose Backshell Style

Jam Nut Receptacles



OR
Square Flange Receptacles



Plug



Backshell



SEE TABLE ON NEXT PAGE FOR PART DETAILS

CONTACTS SOLD SEPARATELY SEE PAGE 92

Shell Size: 14 Number of Contacts: 8 Contact Size: 16
Sealing: IP67 Salt Spray: 48h

eco | mate[®] rm
Standard Products

- Suitable For Indoor and Outdoor Applications
- EMI/RMI Shielding Capability with Appropriate Backshell
- Operating Temperature: -40°C to +105°C
- 500 Mating Cycles
- Contacts and Cord Grips Ordered Separately
- UL ECBT2 Certified*

An upgraded silicone seal is available for all connector parts. Please add "03" to the end of the part number when ordering. Operating Temperature: -40°C to +125°C. Not available in kits.

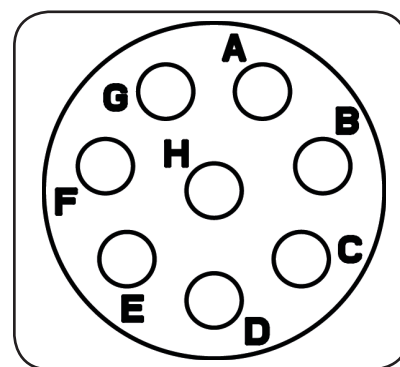

Insert Arrangement
Pin (Male) Faceview

Connector Part Numbers

Part Number		Connector Type	Figure Drawings	
Male	Female		Male	Female
RT07148PNH	RT07148SNH	Jam Nut Receptacle with O-ring Seal	1,5	2,5
RT07148PNHEC	RT07148SNHEC	Jam Nut Receptacle with O-ring Seal and End Cap with Individual Rear Wire Seal**	3,5	4,5
RT06148PNH	RT06148SNH	Plug with O-ring Seal	6	7
RT06148PNHEC	RT06148SNHEC	Plug with O-ring Seal and End Cap with Individual Rear Wire Seal**	8	9
RT00148PNH	RT00148SNH	Square Flange Receptacle with O-ring Seal**	10,14	11,14
RT00148PNHEC	RT00148SNHEC	Square Flange Receptacle with O-ring Seal and End Cap with Individual Rear Wire Seal**	12,14	13,14

Contacts supplied separately see page 92
**See page 89 for the real seal wire range

Backshells

Part Number	Backshell Type	Cable Range (mm)	Figure Drawings	Shielding
RT0S14CGNS1	Short Cord Grip (straight)	6-10.5	15	✓
RT0S14CGNS2	Short Cord Grip (straight)	8.5-12.5	15	✓
RT0L14CGNS1	Long Cord Grip (straight)	6-10.5	16	✓
RT0L14CGNS2	Long Cord Grip (straight)	8.5-12.5	16	✓
RT0B14CGNS1	Cord Grip (90°)	6-10.5	17	✓
RT0B14CGNS2	Cord Grip (90°)	8.0-12.5	17	✓

*Connector parts with part numbers ending in EC (with an end cap) were not available for submittal at the time of UL certification.

Shell Size: 14 Number of Contacts: 8
 Sealing: IP67 Salt Spray: 48h

Contact Size: 16

Dimensions Jam Nut Receptacle

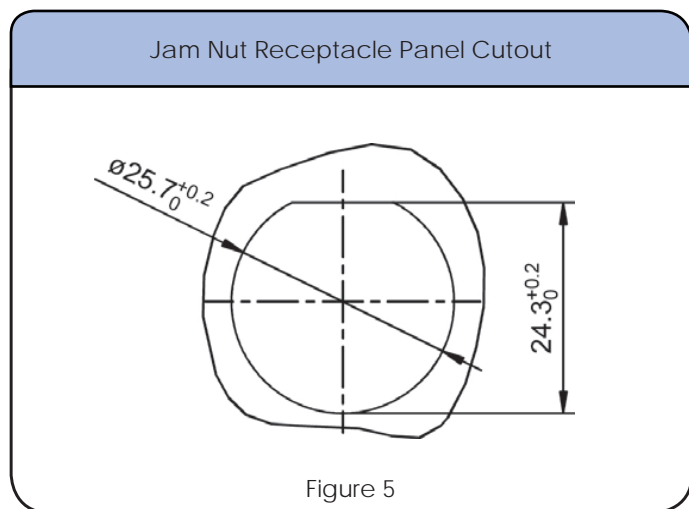
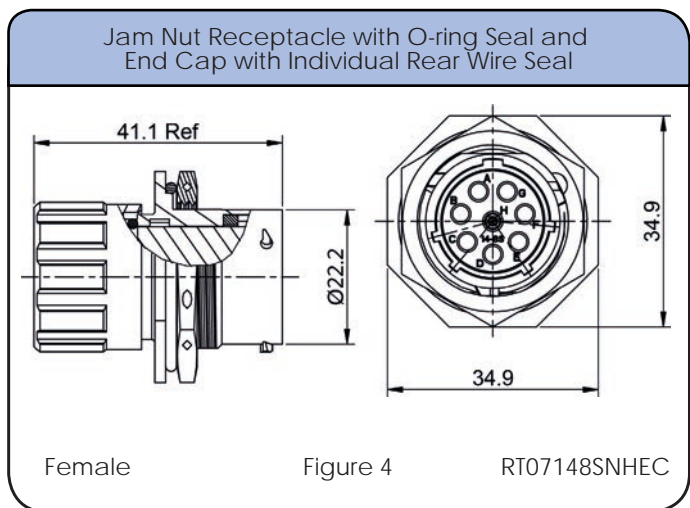
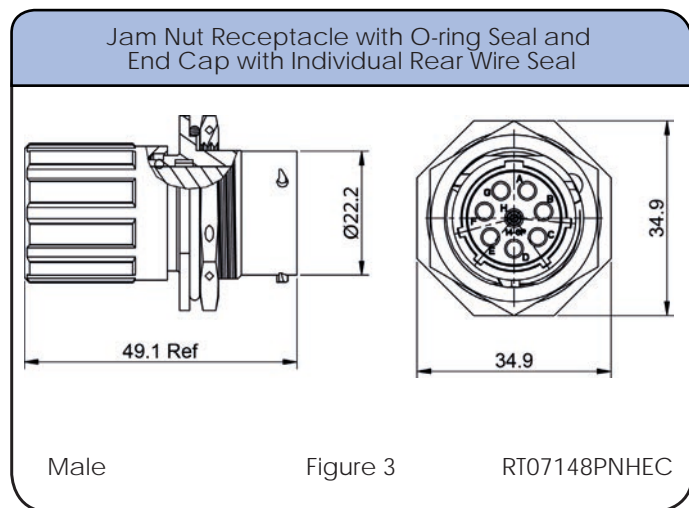
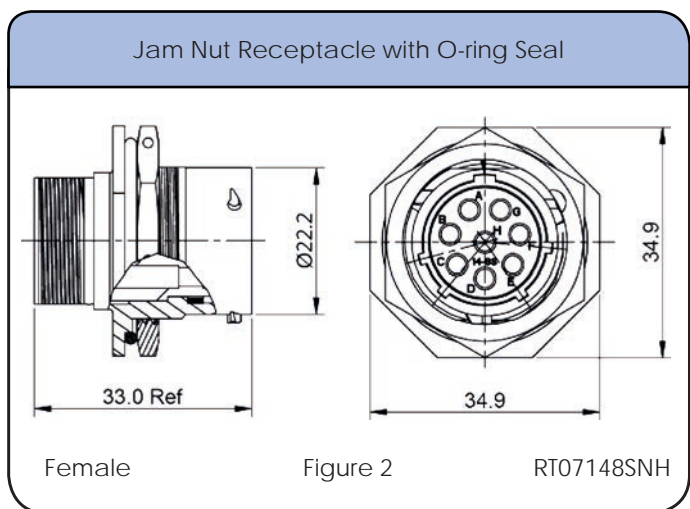
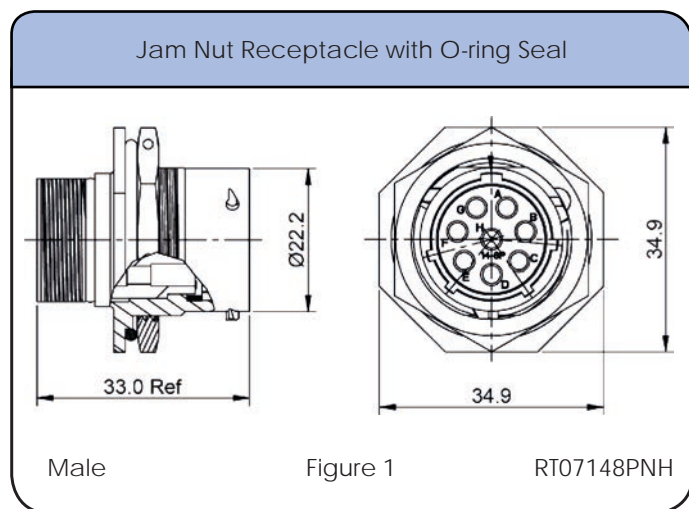

Shell Size: 14 Number of Contacts: 8 Contact Size: 16
Sealing: IP67 Salt Spray: 48h

Dimensions Plug

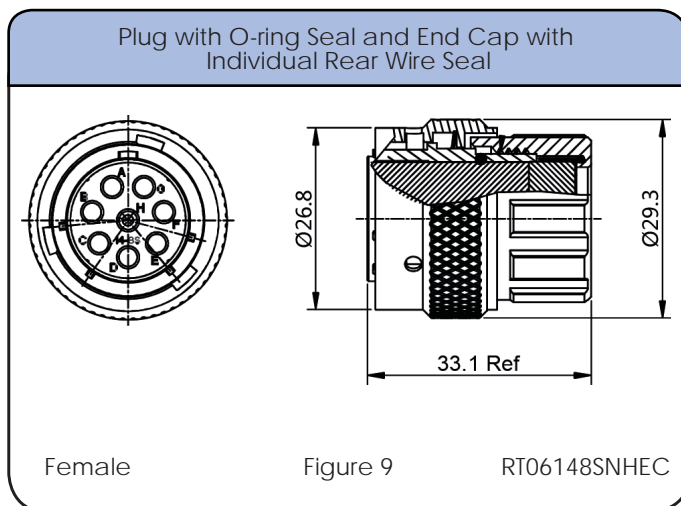
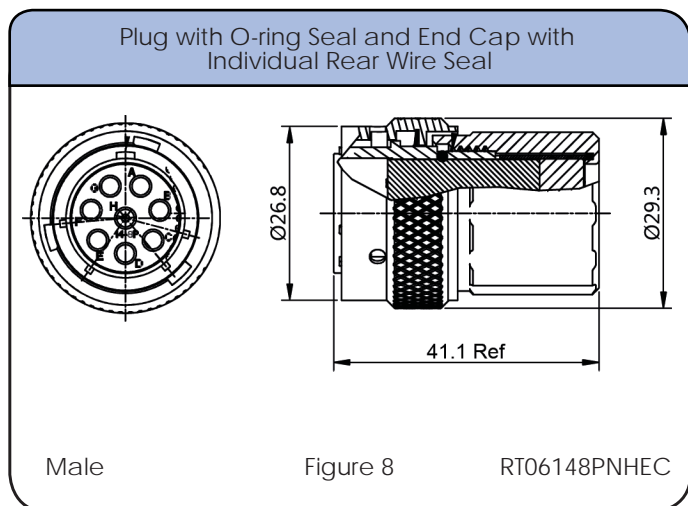
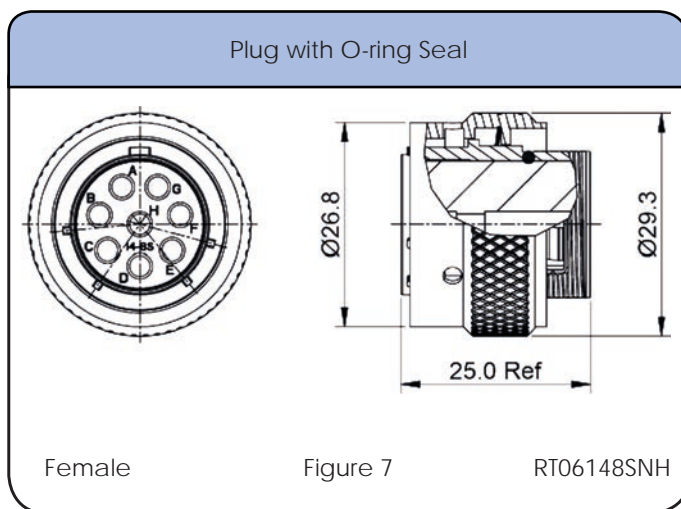
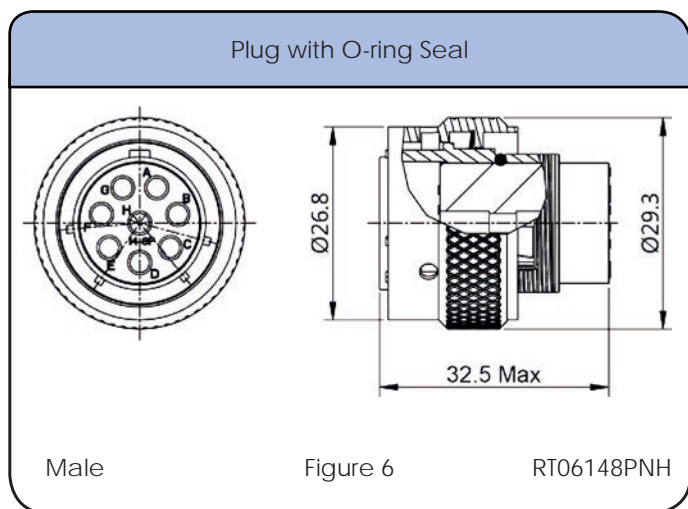

Individual Sealing Wire Range

Contact Size	Insulation Overall Diameter (min-max)	Wire Range
16	Ø2.0mm - Ø3.2mm	14 - 24 AWG

Shell Size: 14 Number of Contacts: 8 Contact Size: 16
 Sealing: IP67 Salt Spray: 48h

Dimensions Square Flange Receptacle

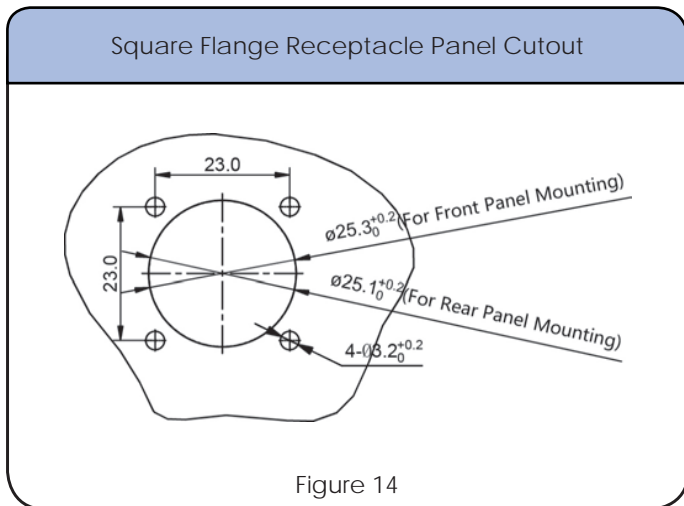
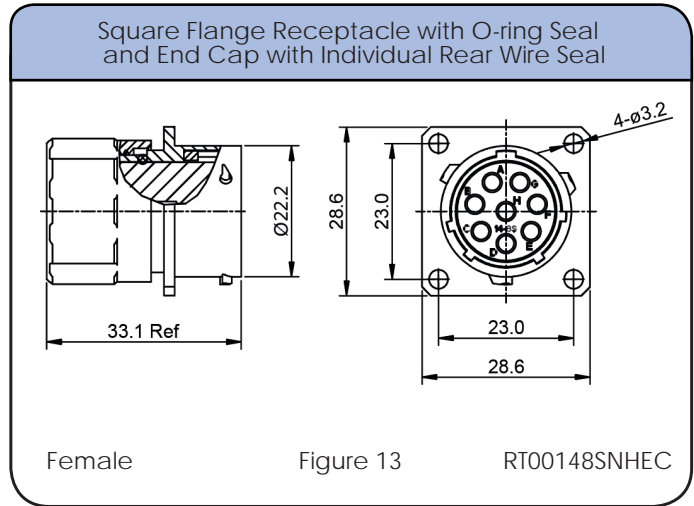
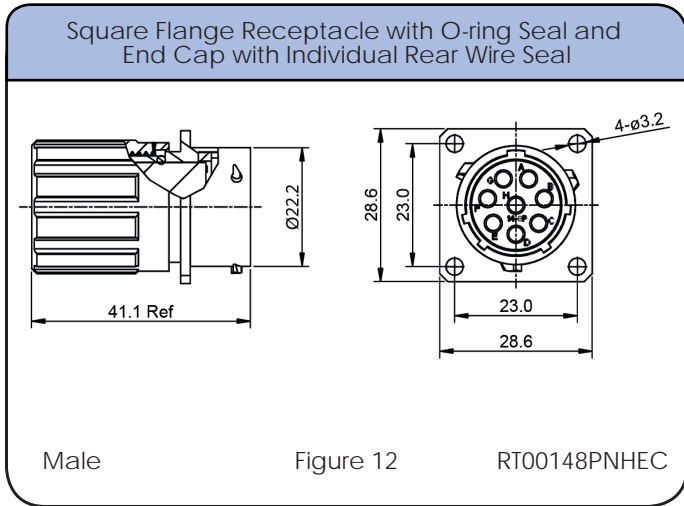
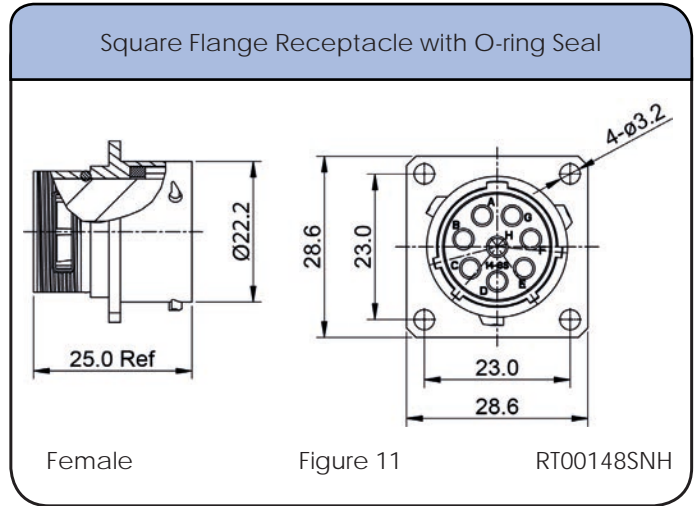
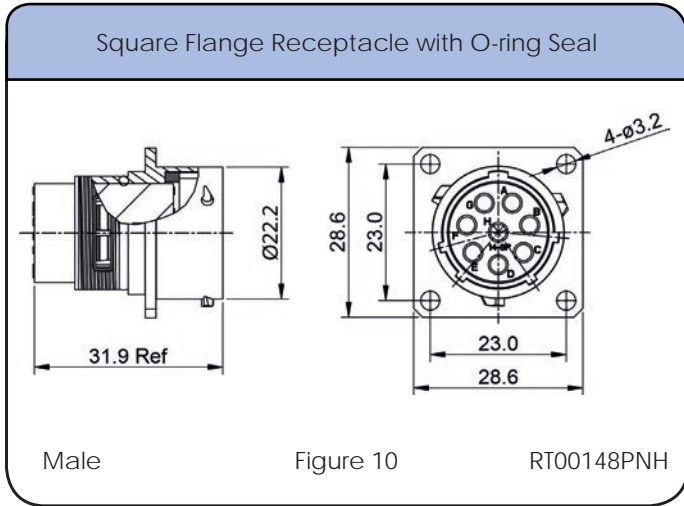

Shell Size: 14 Number of Contacts: 8 Contact Size: 16
Sealing: IP67 Salt Spray: 48h

Dimensions Backshell

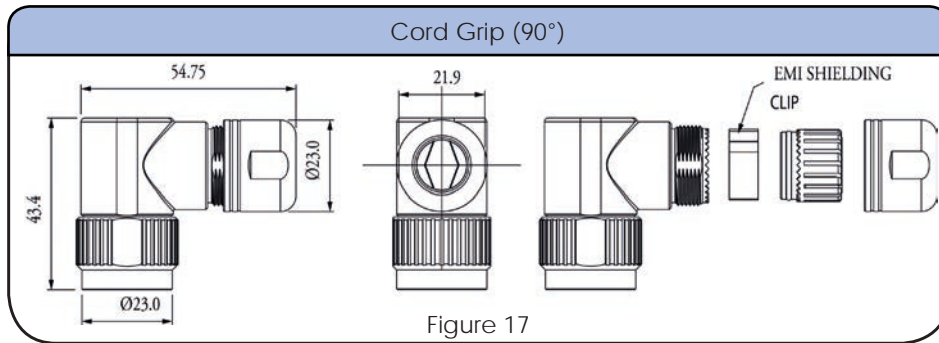
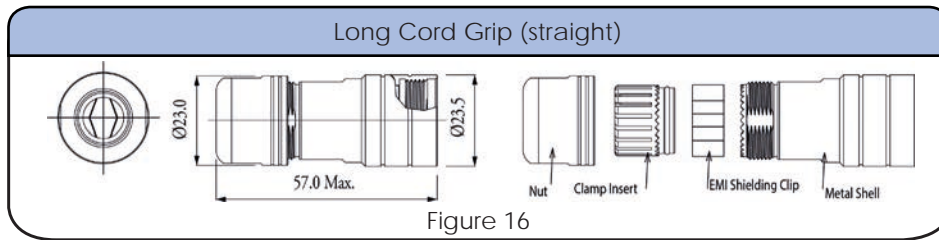
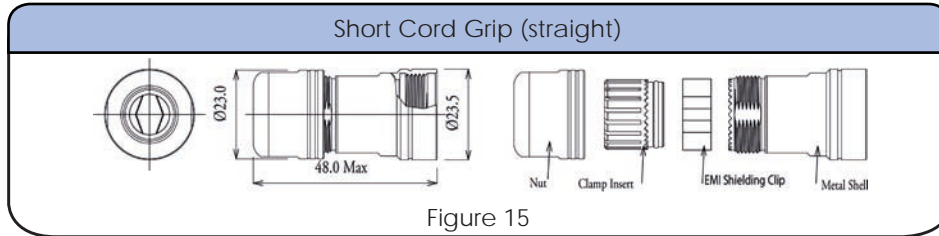

Accessories

<p>Locking Clip with Lanyard</p> <p>108039114</p>	<p>Plug Dustcap with Chain</p> <p>RT614DCG</p>	<p>Plug Dustcap without Chain</p> <p>RT614DC</p>	<p>Receptacle Dustcap with Chain</p> <p>RT014DCG</p>
<p>Receptacle Dustcap with Nylon Cord, Made of Rubber</p> <p>RT014RL</p>	<p>Receptacle Dustcap without Chain</p> <p>RT014DC</p>	<p>Receptacle Dustcap without Nylon Cord, Rubber Material</p> <p>RB00011914</p>	<p>Sealing Plug</p> <p>CA401659</p>
<p>Square Flange Receptacle Gaskets, Thickness 0.8mm (±0.2)</p> <p>RTFD12B</p>			

NEW!
See
Page
16

Shell Size: 14
Sealing: IP67

Number of Contacts: 8
Salt Spray: 48h

Contact Size: 16

Contacts



Crimp Contacts, Machined

Part Number		AWG	Wire Range (mm ²)	Plating
Male	Female			
MP14M23F	MS14M23F	14	2.0-2.5	Gold Flash
MP14M23G5	MS14M23G5	14	2.0-2.5	Gold 5μ"
MP14M23G10	MS14M23G10	14	2.0-2.5	Gold 10μ"
MP14M23G15	MS14M23G15	14	2.0-2.5	Gold 15μ"
MP14M23G30	MS14M23G30	14	2.0-2.5	Gold 30μ"
MP16M23F	MS16M23F	18-16	.75-1.5	Gold Flash
MP16M23G5	MS16M23G5	18-16	.75-1.5	Gold 5μ"
MP16M23G10	MS16M23G10	18-16	.75-1.5	Gold 10μ"
MP16M23G15	MS16M23G15	18-16	.75-1.5	Gold 15μ"
MP16M23G30	MS16M23G30	18-16	.75-1.5	Gold 30μ"
MP20M23F	MS20M23F	22-20	.34-.50	Gold Flash
MP20M23G5	MS20M23G5	22-20	.34-.50	Gold 5μ"
MP20M23G10	MS20M23G10	22-20	.34-.50	Gold 10μ"
MP20M23G15	MS20M23G15	22-20	.34-.50	Gold 15μ"
MP20M23G30	MS20M23G30	22-20	.34-.50	Gold 30μ"
MP24M23F	MS24M23F	26-24	.14-.25	Gold Flash
MP24M23G5	MS24M23G5	26-24	.14-.25	Gold 5μ"
MP24M23G10	MS24M23G10	26-24	.14-.25	Gold 10μ"
MP24M23G15	MS24M23G15	26-24	.14-.25	Gold 15μ"
MP24M23G30	MS24M23G30	26-24	.14-.25	Gold 30μ"

Tools

Contact Extraction Tool,
#16 (Ø 1.6) Contact



QXRT16

Hand Crimp Tool for
Machined Contacts



MFX-3959

Pneumatic Crimp Tool for
Machined Contacts



MFX-3960

Shell Size: 14 Number of Contacts: 8 Contact Size: 16
Sealing: IP67 Salt Spray: 48h

Contacts (con't)



Stamped & Formed Contacts

Crimp Contacts, Stamped & Formed

Part Number		AWG	Wire Range (mm ²)	Plating
Male	Female			
SP14M1F	SS14M1F	14	2.0-2.5	Gold Flash
SP14M1G5	SS14M1G5	14	2.0-2.5	Gold 5μ"
SP14M1G10	SS14M1G10	14	2.0-2.5	Gold 10μ"
SP14M1G15	SS14M1G15	14	2.0-2.5	Gold 15μ"
SP14M1G30	SS14M1G30	14	2.0-2.5	Gold 30μ"
SP16M1F	SS16M1F	18-16	.75-1.5	Gold Flash
SP16M1G5	SS16M1G5	18-16	.75-1.5	Gold 5μ"
SP16M1G10	SS16M1G10	18-16	.75-1.5	Gold 10μ"
SP16M1G15	SS16M1G15	18-16	.75-1.5	Gold 15μ"
SP16M1G30	SS16M1G30	18-16	.75-1.5	Gold 30μ"
SP20M1F	SS20M1F	22-20	.34-.50	Gold Flash
SP20M1G5	SS20M1G5	22-20	.34-.50	Gold 5μ"
SP20M1G10	SS20M1G10	22-20	.34-.50	Gold 10μ"
SP20M1G15	SS20M1G15	22-20	.34-.50	Gold 15μ"
SP20M1G30	SS20M1G30	22-20	.34-.50	Gold 30μ"
SP24M1F	SS24M1F	22-20	.14-.25	Gold Flash
SP24M1G5	SS24M1G5	26-24	.14-.25	Gold 5μ"
SP24M1G10	SS24M1G10	26-24	.14-.25	Gold 10μ"
SP24M1G15	SS24M1G15	26-24	.14-.25	Gold 15μ"
SP24M1G30	SS24M1G30	26-24	.14-.25	Gold 30μ"

Tools



Contact Extraction Tool, #16 (Ø 1.6) Contact

OXRT16



Hand Tool, Stamped & Formed Contact, Size16, 20-14AWG

MFX-3954



Crimp Die for Stamped & Formed Contact

MFX-3957

STEP 1
Choose Receptacle Style

STEP 2
Choose Plug Style

STEP 2
Choose Backshell Style

Jam Nut Receptacles



OR
Square Flange Receptacles



Plug



Backshell



SEE TABLE ON NEXT PAGE FOR PART DETAILS

CONTACTS SOLD SEPARATELY SEE PAGE 100

Shell Size: 18 Number of Contacts: 8 Contact Size: 2.5mm
Sealing: IP67 Salt Spray: 48h

eco | mate[®] rm
Standard Products

- Suitable For Indoor and Outdoor Applications
- EMI/RMI Shielding Capability with Appropriate Backshell
- Operating Temperature: -40°C to +105°C
- 500 Mating Cycles
- Contacts and Cord Grips Ordered Separately
- UL ECBT2 Certified*

An upgraded silicone seal is available for all connector parts. Please add "03" to the end of the part number when ordering. Operating Temperature: -40°C to +125°C. Not available in kits.

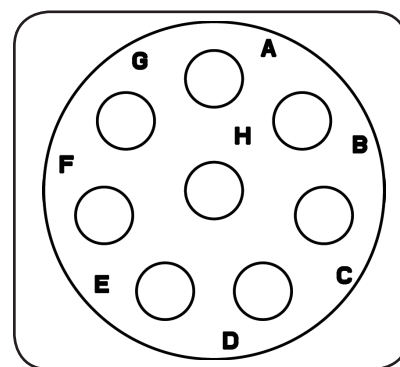

Insert Arrangement
Pin (Male) Faceview

Connector Part Numbers

Part Number		Connector Type	Figure Drawings	
Male	Female		Male	Female
RT07188PNH	RT07188SNH	Jam Nut Receptacle	1,5	2,5
RT07188PNHEC	RT07188SNHEC	Jam Nut Receptacle with O-ring Seal and End Cap with Individual Rear Wire Seal**	3,5	4,5
RT06188PNH	RT06188SNH	Plug	6	7
RT06188PNHEC	RT06188SNHEC	Plug with O-ring Seal and End Cap with Individual Rear Wire Seal**	8	9
RT00188PNH	RT00188SNH	Square Flange Receptacle	10,14	11,14
RT00188PNHEC	RT00188SNHEC	Square Flange Receptacle with O-ring Seal and End Cap with Individual Rear Wire Seal**	12,14	13,14

Contacts supplied separately see page 100
**See page 97 for the real seal wire range

Backshells

Part Number	Backshell Type	Cable Range (mm)	Figure Drawings	Shielding
RT0S18CGNS1	Short Cord Grip (straight)	9.0-14.5	15	✓
RT0S18CGNS2	Short Cord Grip (straight)	13.5-17	15	✓
RT0L18CGNS1	Long Cord Grip (straight)	9.0-14.5	16	✓
RT0L18CGNS2	Long Cord Grip (straight)	13.5-17	16	✓

*Connector parts with part numbers ending in EC (with an end cap) were not available for submittal at the time of UL certification.

Shell Size: 18 Number of Contacts: 8
 Sealing: IP67 Salt Spray: 48h

Contact Size: 2.5mm

Dimensions Jam Nut Receptacle

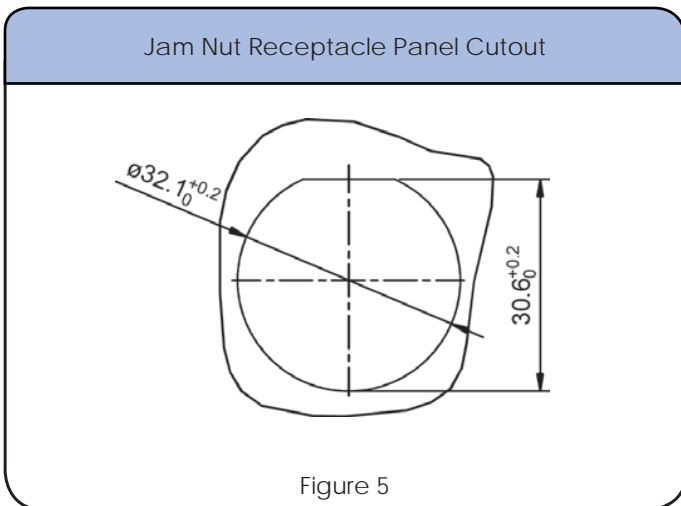
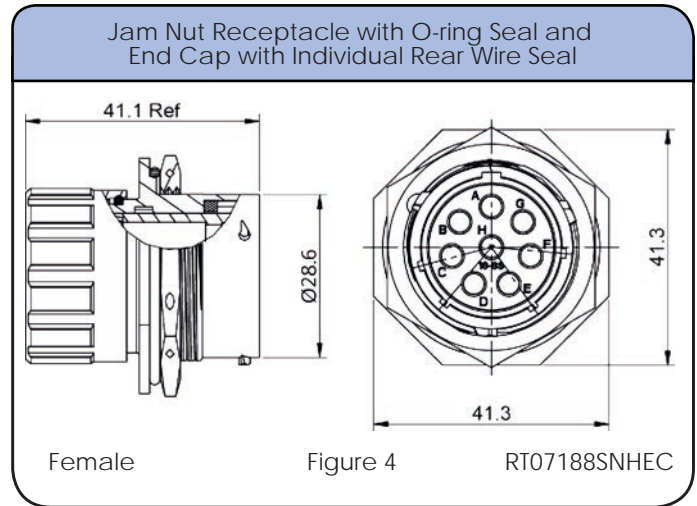
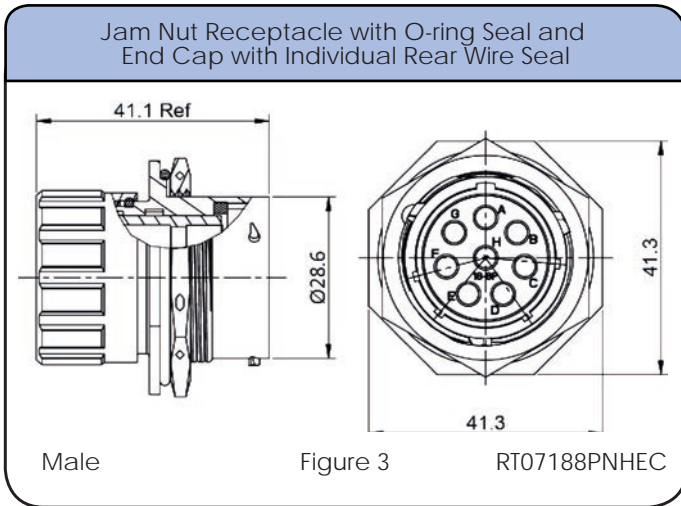
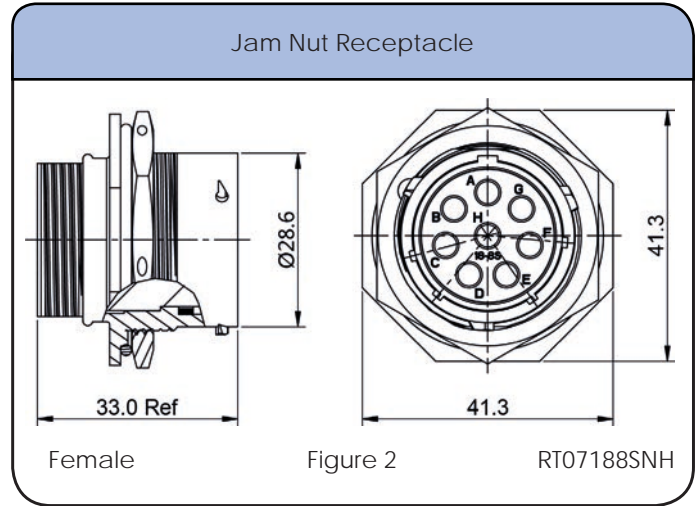
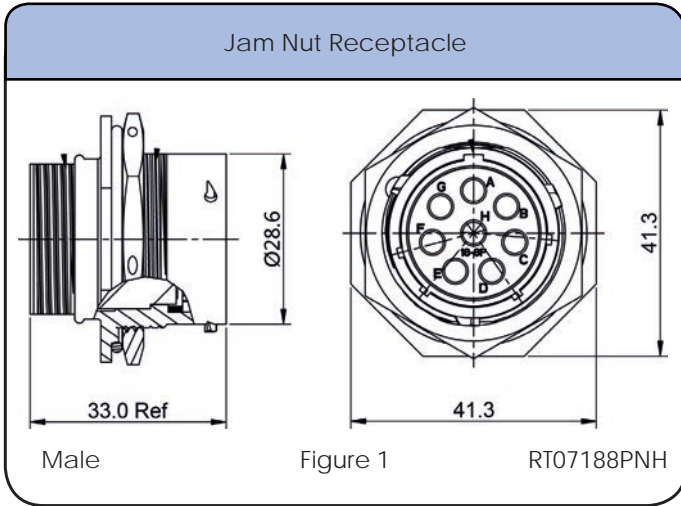

Shell Size: 18 Number of Contacts: 8
Sealing: IP67 Salt Spray: 48h

Contact Size: 2.5mm

Dimensions Plug

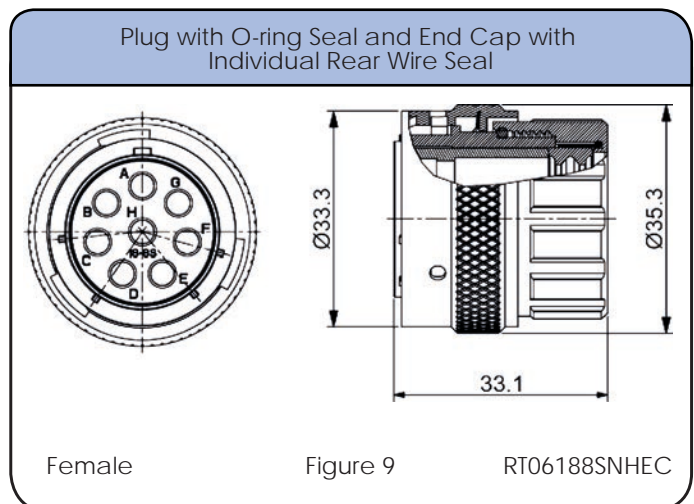
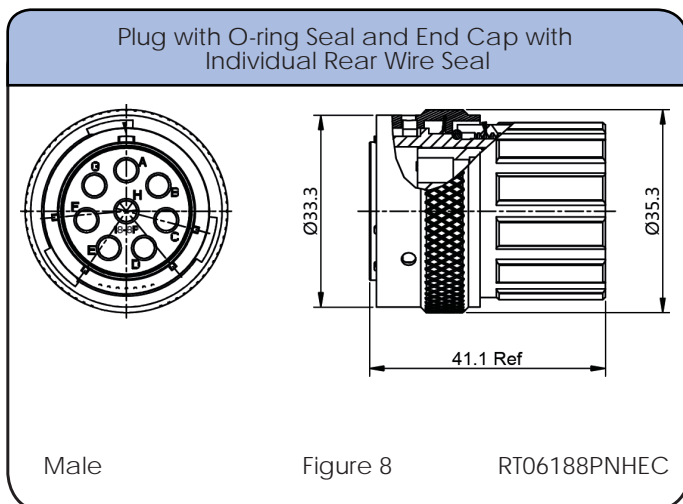
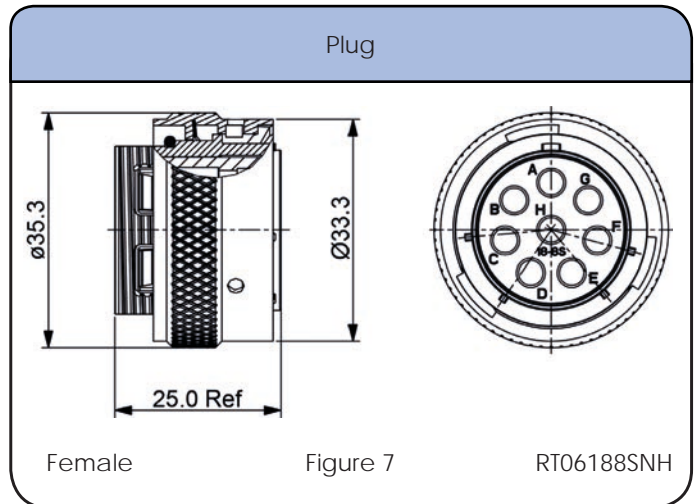
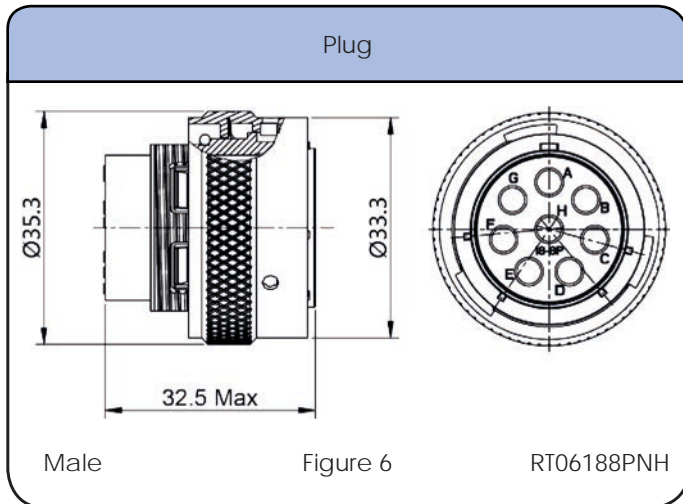

Individual Sealing Wire Range

Contact Size	Insulation Overall Diameter (min-max)	Wire Range
2.5mm	Ø3.3mm - Ø4.3mm	14 - 12 AWG

Shell Size: 18 Number of Contacts: 8 Contact Size: 2.5mm
 Sealing: IP67 Salt Spray: 48h

Dimensions Square Flange Receptacle

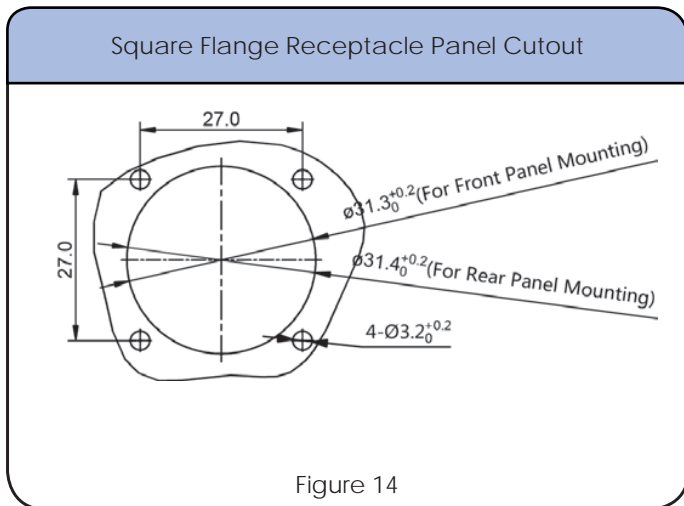
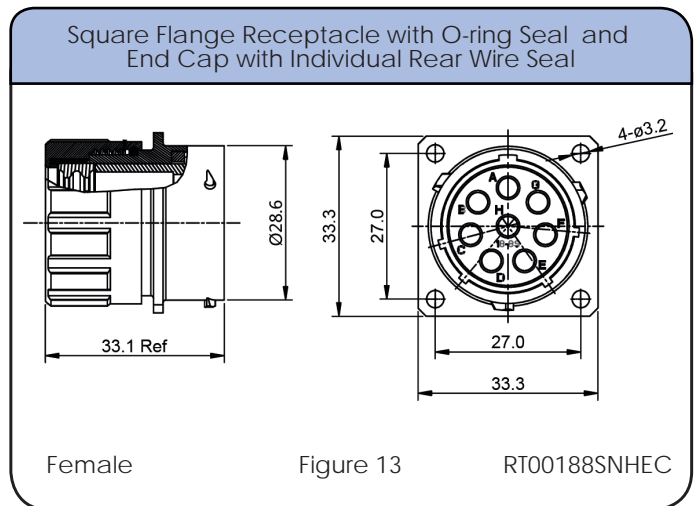
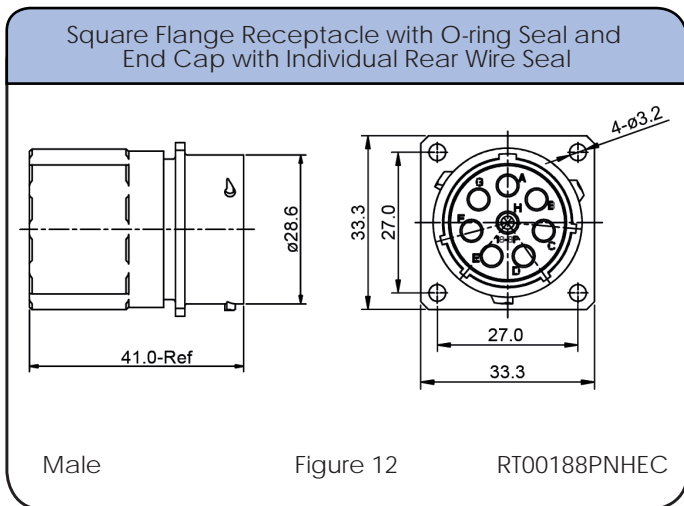
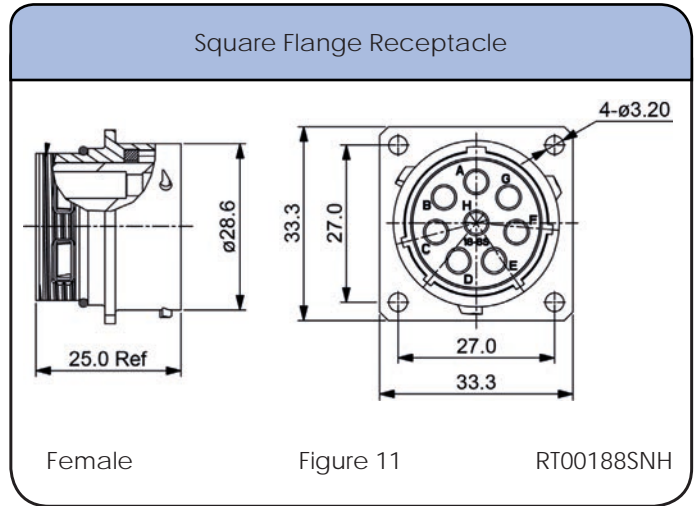
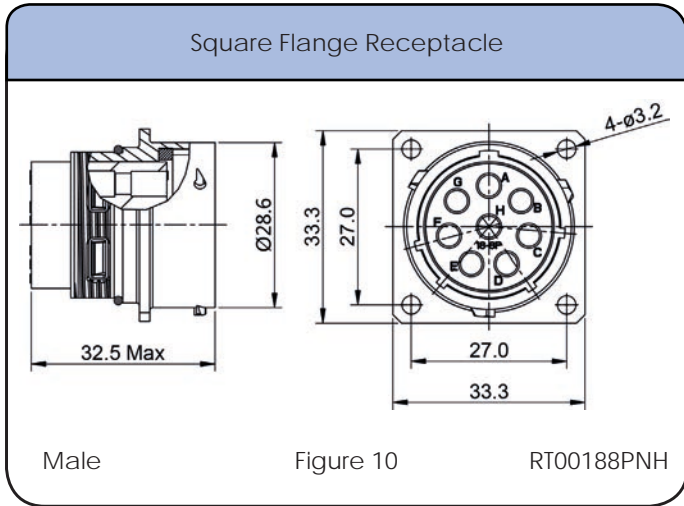

Shell Size: 18 Number of Contacts: 8 Contact Size: 2.5mm
Sealing: IP67 Salt Spray: 48h

Dimensions Backshell

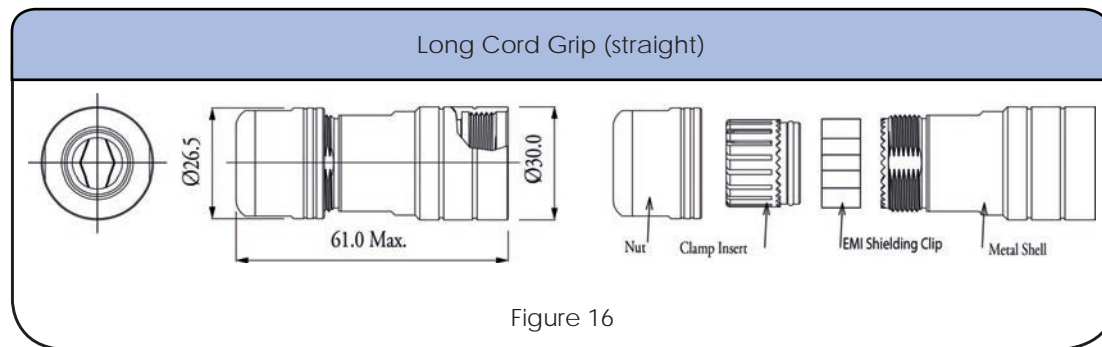
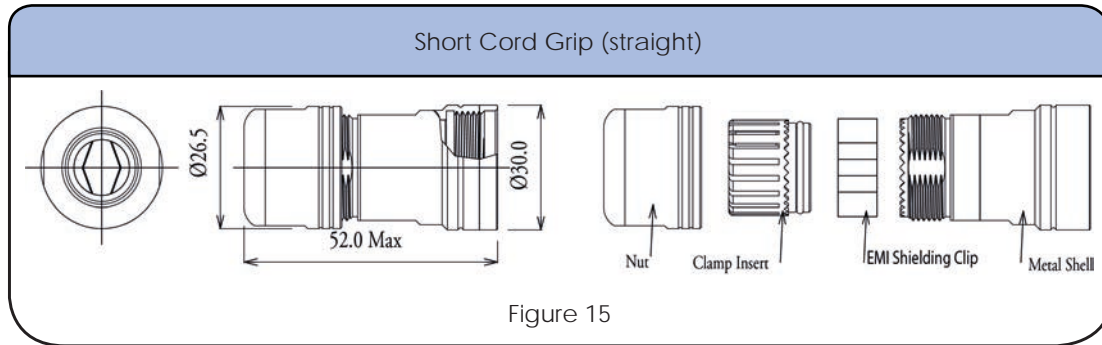

Shell Size: 18
Sealing: IP67

Number of Contacts: 8
Salt Spray: 48h

Contact Size: 2.5mm

Contacts



Crimp Contacts, Stamped & Formed

Part Number		AWG	Wire Range (mm ²)	Plating
Male	Female			
SP12A1T	SS12A1T	14-12	2.5-3.5	Tin









no machined contacts are available for this group

Tools



Shell Size: 18 Number of Contacts: 8 Contact Size: 2.5mm
Sealing: IP67 Salt Spray: 48h

Accessories

<p>Plug Dustcap with Chain</p>  <p>RT618DCG</p>	<p>Plug Dustcap without Chain</p>  <p>RT618DC</p>	<p>Receptacle Dustcap with Chain</p>  <p>RT018DCG</p>
<p>Receptacle Dustcap with Nylon Cord, Made of Rubber</p>  <p>RT018RL</p>	<p>Receptacle Dustcap without Chain</p>  <p>RT018DC</p>	<p>Receptacle Dustcap without Nylon Cord, Rubber Material</p>  <p>RB00011918</p>
<p>Sealing Plug</p>  <p>CA401259</p>	<p>Square Flange Receptacle Gaskets, Thickness 0.8mm (± 0.2)</p>  <p>RTFD18B</p>	<p>Locking Clip with Lanyard</p>  <p>108039118</p>

NEW!
See Page 16

STEP 1
Choose Receptacle Style

STEP 2
Choose Plug Style

STEP 2
Choose Backshell Style

Jam Nut Receptacles



OR
Square Flange Receptacles



Plug



Backshell



SEE TABLE ON NEXT PAGE FOR PART DETAILS

CONTACTS SOLD SEPARATELY SEE PAGE 108

Shell Size: 16 Number of Contacts: 9 Contact Size: Mixed 2.5mm & 16
Sealing: IP67 Salt Spray: 48h

eco | mate[®] rm Standard Products

- Suitable For Indoor and Outdoor Applications
- EMI/RMI Shielding Capability with Appropriate Backshell
- Operating Temperature: -40°C to +105°C
- 500 Mating Cycles
- Contacts and Cord Grips Ordered Separately
- UL ECBT2 Certified*

An upgraded silicone seal is available for all connector parts. Please add "03" to the end of the part number when ordering. Operating Temperature: -40°C to +125°C. Not available in kits.

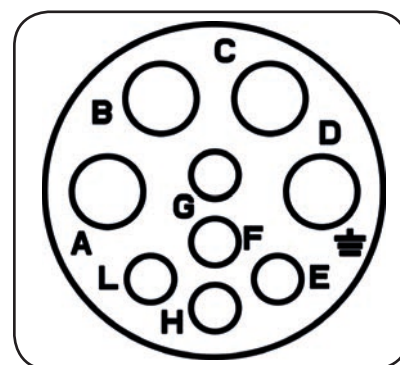

Insert Arrangement
Pin (Male) Faceview

Connector Part Numbers

Part Number		Connector Type	Figure Drawings	
Male	Female		Male	Female
RT071609PNH	RT071609SNH	Jam Nut Receptacle with O-ring Seal	1,5	2,5
RT07169PNHEC	RT07169SNHEC	Jam Nut Receptacle with O-ring Seal and End Cap with Individual Rear Wire Seal**	3,5	4,5
RT061609PNH	RT061609SNH	Plug with O-ring Seal	6	7
RT061609PNHEC	RT061609SNHEC	Plug with O-ring Seal and End Cap with Individual Rear Wire Seal**	8	9
RT00169PNH	RT00169SNH	Square Flange Receptacle with O-ring Seal	10,14	11,14
RT00169PNHEC	RT00169SNHEC	Square Flange Receptacle with O-ring Seal and End Cap with Individual Rear Wire Seal**	12,14	13,14

Contacts supplied separately see page 108
**See page 105 for the real seal wire range

Backshells

Part Number	Backshell Type	Cable Range (mm)	Figure Drawings	Shielding
RT0S16CGNS1	Short Cord Grip (straight)	9.0-14.5	15	✓
RT0S16CGNS2	Short Cord Grip (straight)	13.5-17	15	✓
RT0L16CGNS1	Long Cord Grip (straight)	9.0-14.5	16	✓
RT0L16CGNS2	Long Cord Grip (straight)	13.5-17	16	✓
RT0B16CGNS1	Cord Grip (90°)	9.5-14.5	17	✓
RT0B16CGNS2	Cord Grip (90°)	13.5-17.0	17	✓

*Connector parts with part numbers ending in EC (with an end cap) were not available for submittal at the time of UL certification.

Shell Size: 16 Number of Contacts: 9
 Sealing: IP67 Salt Spray: 48h

Contact Size: Mixed 2.5mm & 16

Dimensions Jam Nut Receptacle

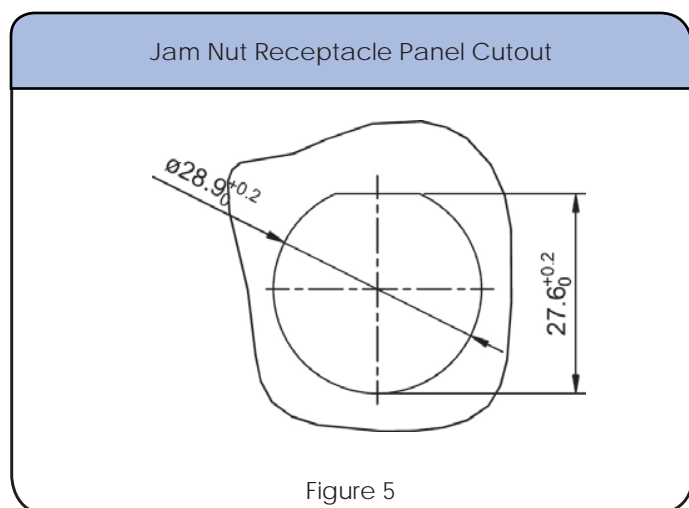
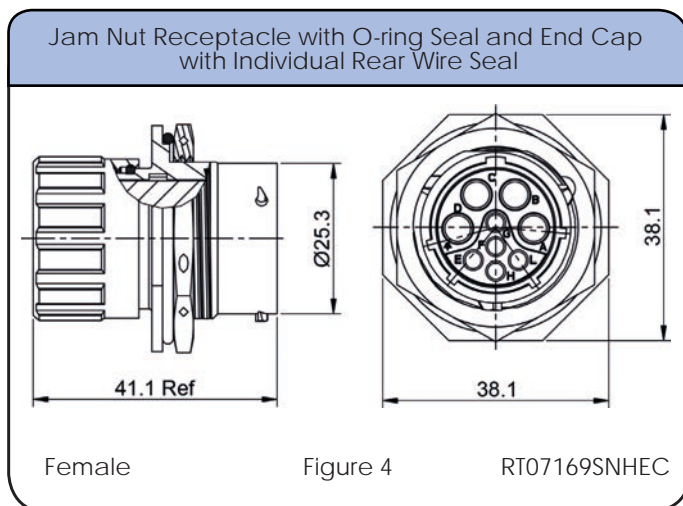
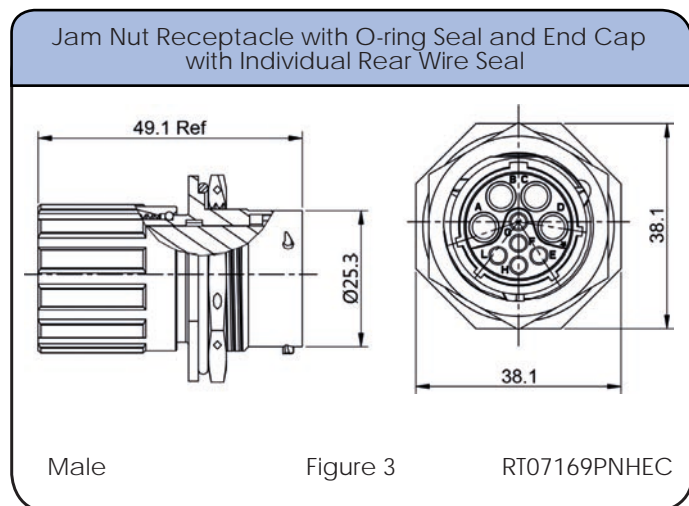
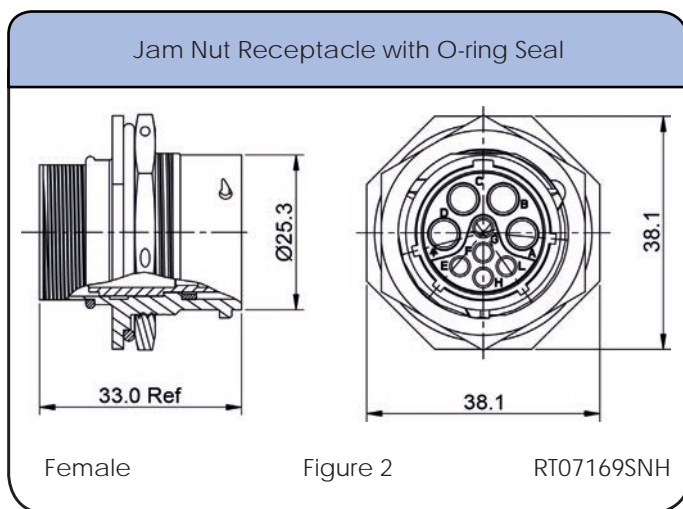
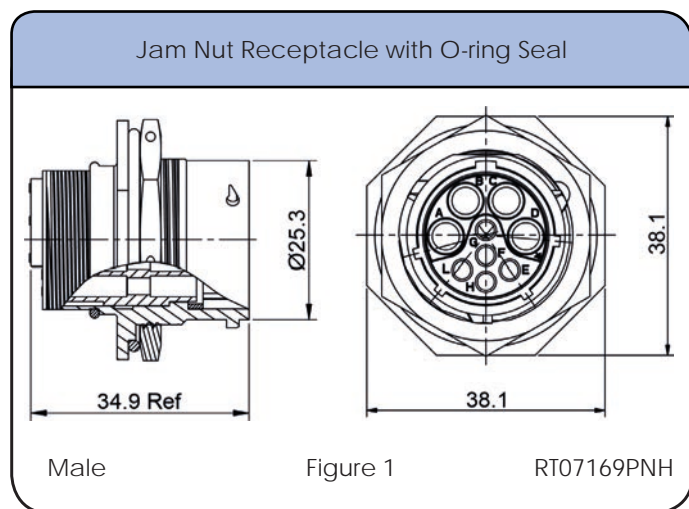

Shell Size: 16 Number of Contacts: 9
Sealing: IP67 Salt Spray: 48h

Contact Size: Mixed 2.5mm & 16

Dimensions Plug

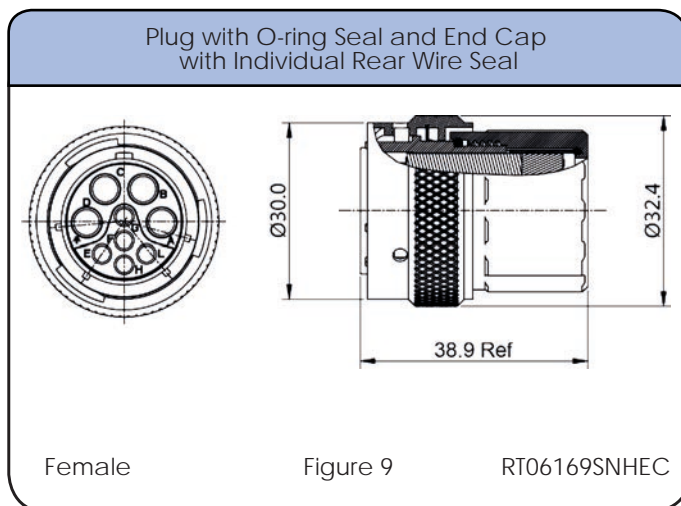
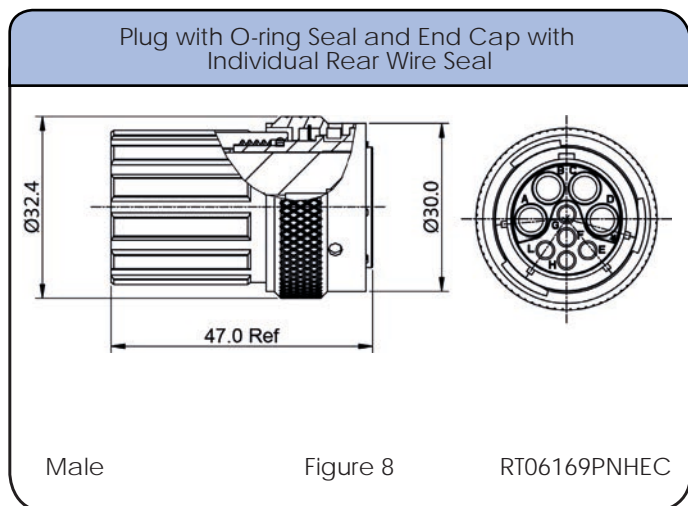
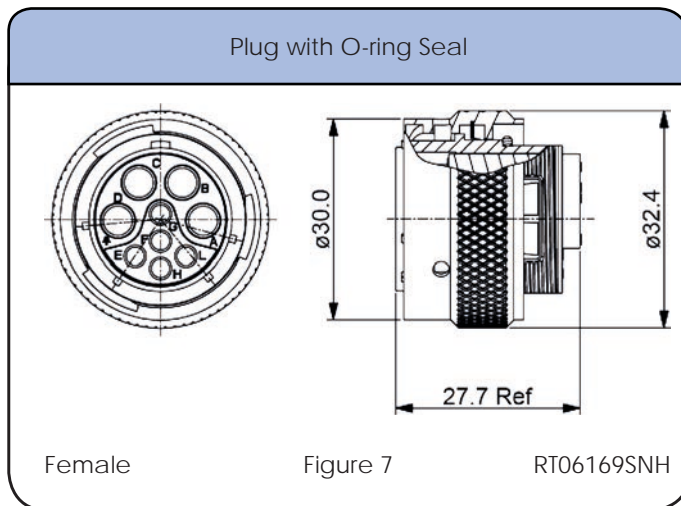
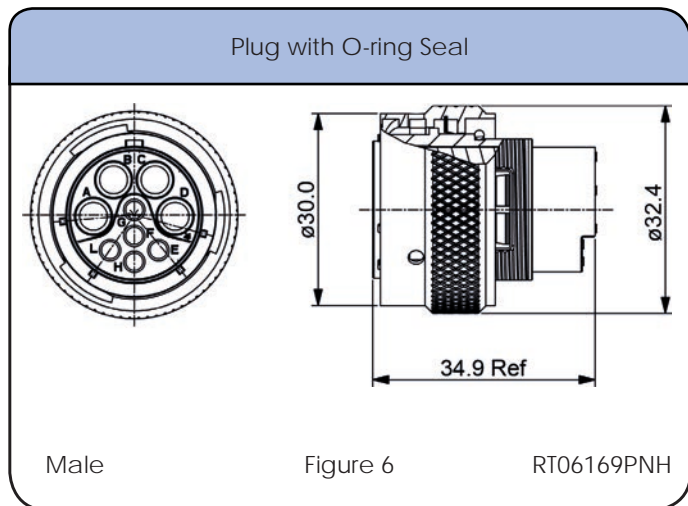

Individual Sealing Wire Range

Contact Size	Insulation Overall Diameter (min-max)	Wire Range
2.5mm	Ø3.3mm - Ø4.3mm	14 - 12 AWG
16	Ø2.0mm - Ø3.2mm	14 - 24 AWG

Shell Size: 16 Number of Contacts: 9 Contact Size: Mixed 2.5mm & 16
 Sealing: IP67 Salt Spray: 48h

Dimensions Square Flange Receptacle

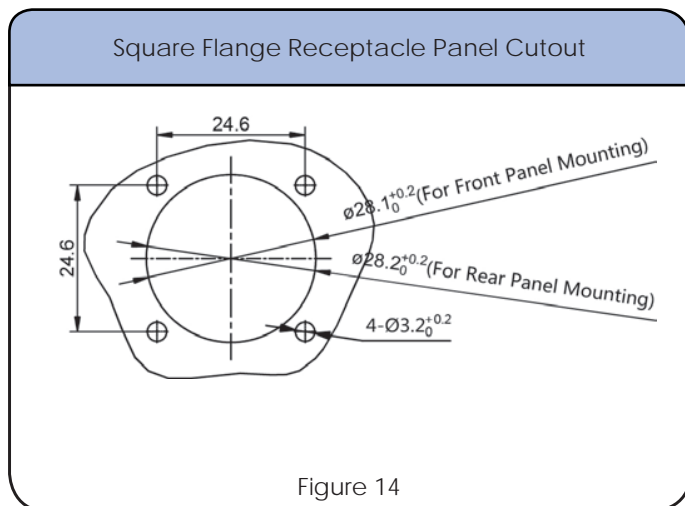
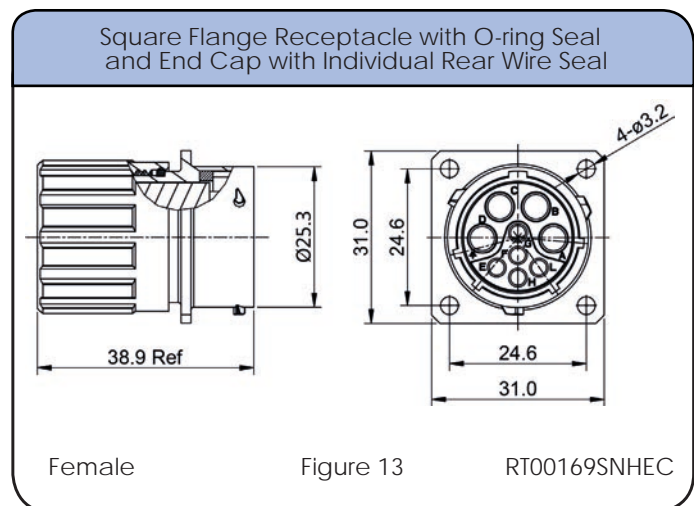
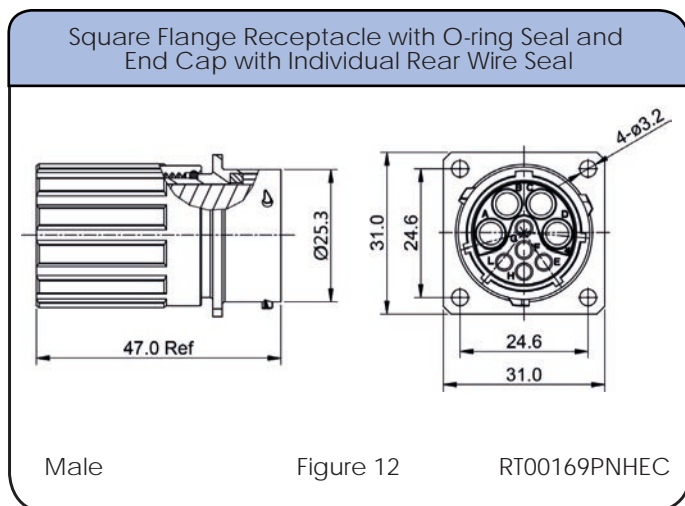
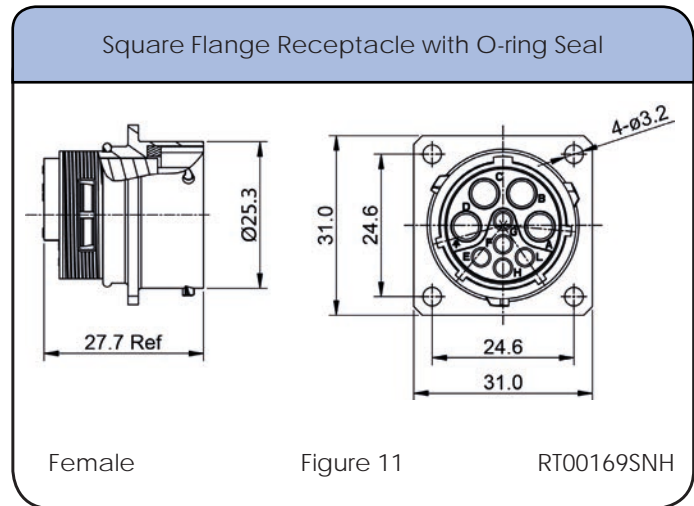
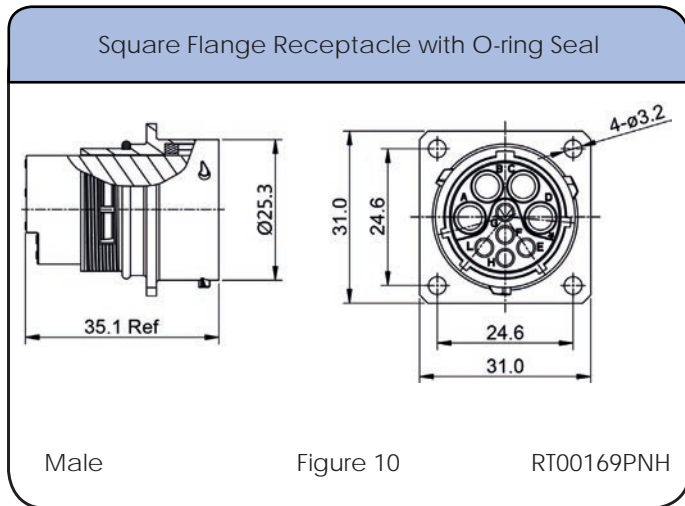

Shell Size: 16 Number of Contacts: 9 Contact Size: Mixed 2.5mm & 16
Sealing: IP67 Salt Spray: 48h

Dimensions Backshell

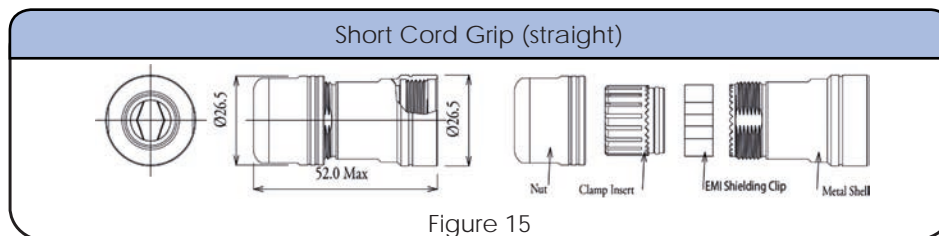

Figure 15

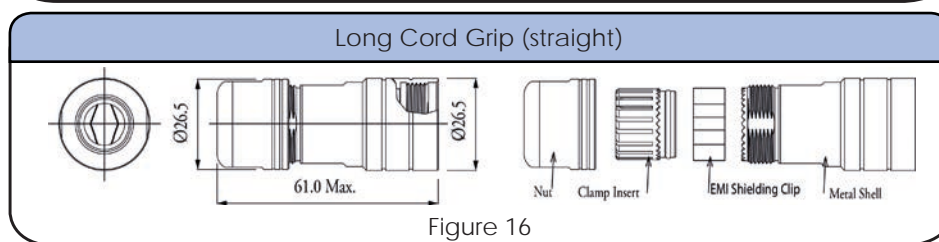

Figure 16

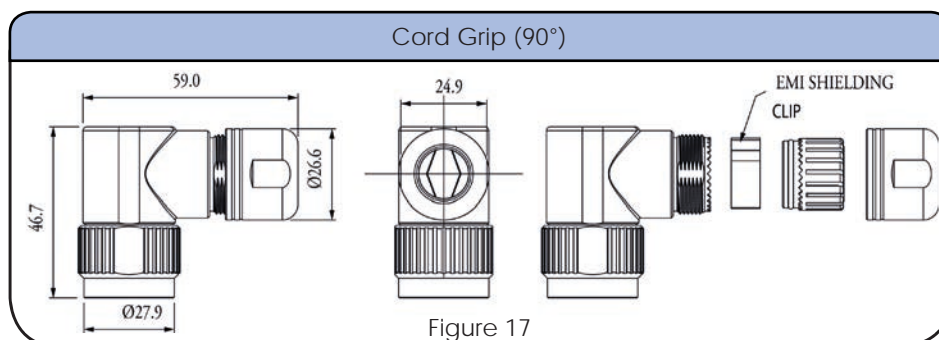

Figure 17

Accessories



RT16DCG



RT16DC

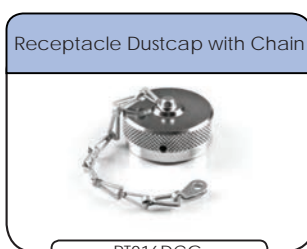

RT016DCG



RT016RL



RT016DC



RB00011916



CA401659

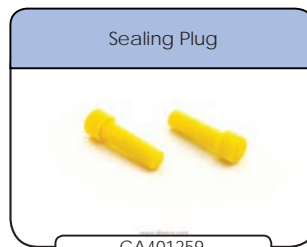

CA401259



RTFD16B



108039116



Shell Size: 16
Sealing: IP67

Number of Contacts: 9
Salt Spray: 48h

Contact Size: Mixed 2.5mm & 16

Contacts



Crimp Contacts, Machined

Part Number		Contact Size	AWG	Wire Range (mm ²)	Plating
Male	Female				
MP14M23F	MS14M23F	16	14	2.0-2.5	Gold Flash
MP14M23G5	MS14M23G5	16	14	2.0-2.5	Gold 5μ"
MP14M23G10	MS14M23G10	16	14	2.0-2.5	Gold 10μ"
MP14M23G15	MS14M23G15	16	14	2.0-2.5	Gold 15μ"
MP14M23G30	MS14M23G30	16	14	2.0-2.5	Gold 30μ"
MP16M23F	MS16M23F	16	18-16	.75-1.5	Gold Flash
MP16M23G5	MS16M23G5	16	18-16	.75-1.5	Gold 5μ"
MP16M23G10	MS16M23G10	16	18-16	.75-1.5	Gold 10μ"
MP16M23G15	MS16M23G15	16	18-16	.75-1.5	Gold 15μ"
MP16M23G30	MS16M23G30	16	18-16	.75-1.5	Gold 30μ"
MP20M23F	MS20M23F	16	22-20	.34-.50	Gold Flash
MP20M23G5	MS20M23G5	16	22-20	.34-.50	Gold 5μ"
MP20M23G10	MS20M23G10	16	22-20	.34-.50	Gold 10μ"
MP20M23G15	MS20M23G15	16	22-20	.34-.50	Gold 15μ"
MP20M23G30	MS20M23G30	16	22-20	.34-.50	Gold 30μ"
MP24M23F	MS24M23F	16	26-24	.14-.25	Gold Flash
MP24M23G5	MS24M23G5	16	26-24	.14-.25	Gold 5μ"
MP24M23G10	MS24M23G10	16	26-24	.14-.25	Gold 10μ"
MP24M23G15	MS24M23G15	16	26-24	.14-.25	Gold 15μ"
MP24M23G30	MS24M23G30	16	26-24	.14-.25	Gold 30μ"

Tools

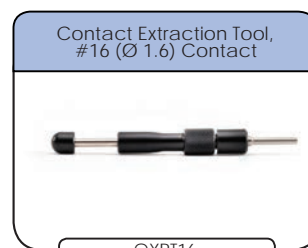

Shell Size: 16 Number of Contacts: 9
Sealing: IP67 Salt Spray: 48h

Contact Size: Mixed 2.5mm & 16

Contacts (con't)



Crimp Contacts, Stamped & Formed

Part Number		Contact Size	AWG	Wire Range (mm ²)	Plating
Male	Female				
SP12A1T	SS12A1T	2.5mm	14-12	2.0-2.5	Tin
SP14M1F	SS14M1F	16	14	2.0-2.5	Gold Flash
SP14M1G5	SS14M1G5	16	14	2.0-2.5	Gold 5μ"
SP14M1G10	SS14M1G10	16	14	2.0-2.5	Gold 10μ"
SP14M1G15	SS14M1G15	16	14	2.0-2.5	Gold 15μ"
SP14M1G30	SS14M1G30	16	14	2.0-2.5	Gold 30μ"
SP16M1F	SS16M1F	16	18-16	.75-1.5	Gold Flash
SP16M1G5	SS16M1G5	16	18-16	.75-1.5	Gold 5μ"
SP16M1G10	SS16M1G10	16	18-16	.75-1.5	Gold 10μ"
SP16M1G15	SS16M1G15	16	18-16	.75-1.5	Gold 15μ"
SP16M1G30	SS16M1G30	16	18-16	.75-1.5	Gold 30μ"
SP20M1F	SS20M1F	16	22-20	.34-.50	Gold Flash
SP20M1G5	SS20M1G5	16	22-20	.34-.50	Gold 5μ"
SP20M1G10	SS20M1G10	16	22-20	.34-.50	Gold 10μ"
SP20M1G15	SS20M1G15	16	22-20	.34-.50	Gold 15μ"
SP20M1G30	SS20M1G30	16	22-20	.34-.50	Gold 30μ"
SP24M1F	SS24M1F	16	22-20	.14-.25	Gold Flash
SP24M1G5	SS24M1G5	16	26-24	.14-.25	Gold 5μ"
SP24M1G10	SS24M1G10	16	26-24	.14-.25	Gold 10μ"
SP24M1G15	SS24M1G15	16	26-24	.14-.25	Gold 15μ"
SP24M1G30	SS24M1G30	16	26-24	.14-.25	Gold 30μ"

Tools

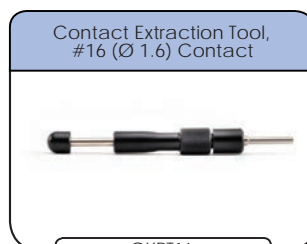

STEP 1
Choose Receptacle Style

STEP 2
Choose Plug Style

STEP 2
Choose Backshell Style

Jam Nut Receptacles



OR
Square Flange Receptacles



Jam Nut Receptacle Kit Including Receptacle & Contacts



Square Flange Receptacle Kit Including Receptacle, Gasket & Contacts



Plug



Backshell



OR
Plug Kit Including Connector, Backshell & Contacts



SEE TABLE ON NEXT PAGE FOR PART DETAILS

CONTACTS SOLD SEPARATELY SEE PAGE 116

Shell Size: 12 Number of Contacts: 10 Contact Size: 20
Sealing: IP67 Salt Spray: 48h

eco | mate[®] rm
Standard Products

- Suitable For Indoor and Outdoor Applications
- EMI/RMI Shielding Capability with Appropriate Backshell
- Operating Temperature: -40°C to +105°C
- 500 Mating Cycles
- Contacts and Cord Grips Ordered Separately
- UL ECBT2 Certified*

An upgraded silicone seal is available for all connector parts. Please add "03" to the end of the part number when ordering. Operating Temperature: -40°C to +125°C. Not available in kits.

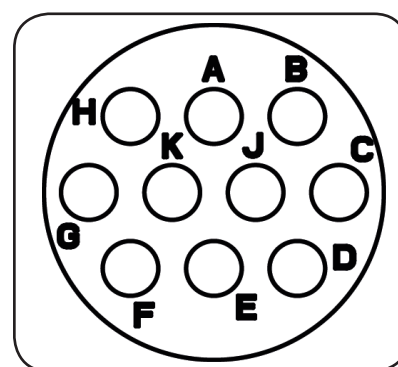

Insert Arrangement
Pin (Male) Faceview

Connector Part Numbers

Part Number		Connector Type	Figure Drawings	
Male	Female		Male	Female
RT0W71210PNH	RT0W71210SNH	Jam Nut Receptacle	1,5	2,5
RT0W71210PNHEC	RT0W71210SNHEC	Jam Nut Receptacle with O-ring Seal and End Cap with Individual Rear Wire Seal**	3,5	4,5
RT0W71210PNHK	RT0W71210SNHK	Jam Nut Receptacle Kit	1,5	2,5
RT0W61210PNH	RT0W61210SNH	Plug	6	7
RT0W61210PNHEC	RT0W61210SNHEC	Plug with O-ring Seal and End Cap with Individual Rear Wire Seal**	8	9
RT0W61210PNHK	RT0W61210SNHK	Plug Kit	6	7
RT0W01210PNH	RT0W01210SNH	Square Flange Receptacle	10,14	11,14
RT0W01210PNHEC	RT0W01210SNHEC	Square Flange Receptacle with O-ring Seal and End Cap with Individual Rear Wire Seal**	12,14	13,14
RT0W01210PNHK	RT0W01210SNHK	Square Flange Receptacle Kit	10,14	11,14

Contacts supplied separately see page 116
**See page 113 for the real seal wire range

Backshells

Part Number	Backshell Type	Cable Range (mm)	Figure Drawings	Shielding
RT0S12CGNS1	Short Cord Grip (straight)	6-10.5	15	✓
RT0S12CGNS2	Short Cord Grip (straight)	8.5-12.5	15	✓
RT0L12CGNS1	Long Cord Grip (straight)	6-10.5	16	✓
RT0L12CGNS2	Long Cord Grip (straight)	8.5-12.5	16	✓
RT0B12CGNS1	Cord Grip (90°)	6-10.5	17	✓
RT0B12CGNS2	Cord Grip (90°)	8.0-12.5	17	✓

*Connector parts with part numbers ending in EC (with an end cap) were not available for submittal at the time of UL certification.

Shell Size: 12 Number of Contacts: 10
 Sealing: IP67 Salt Spray: 48h

Contact Size: 20

Dimensions Jam Nut Receptacle

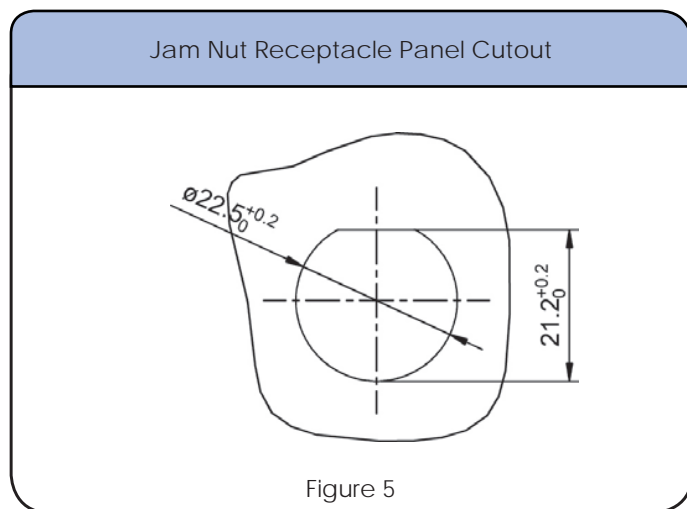
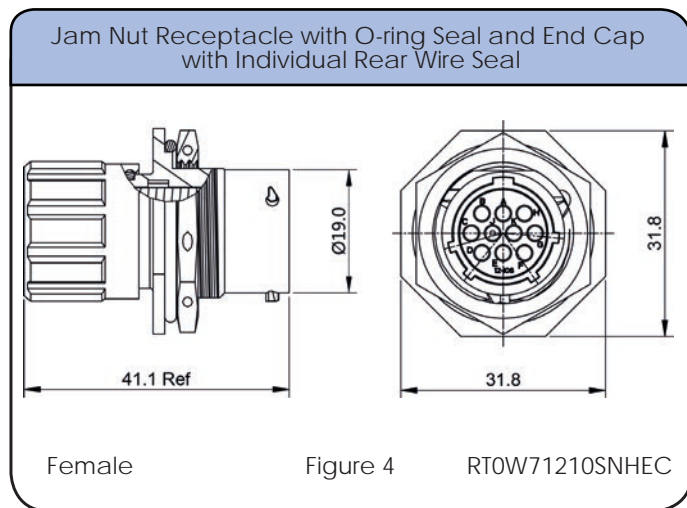
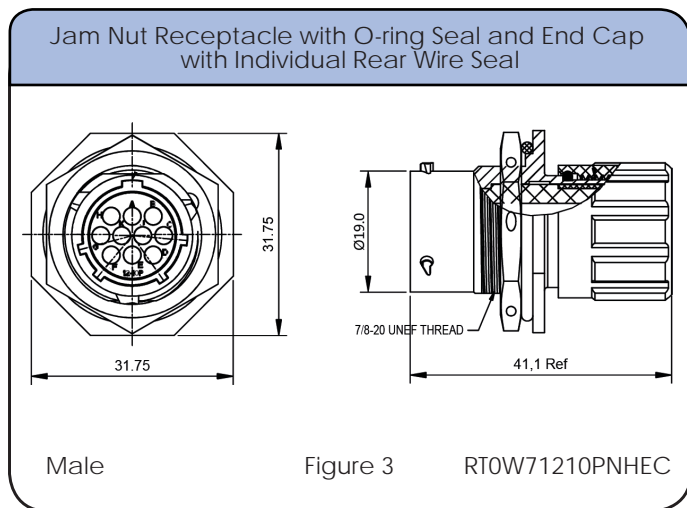
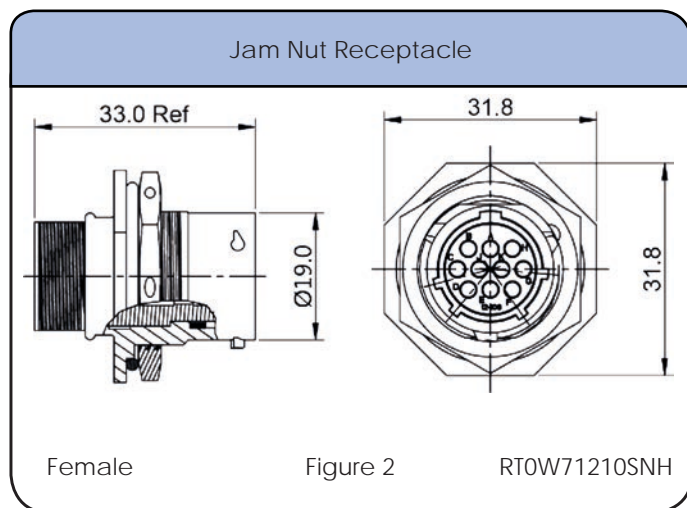
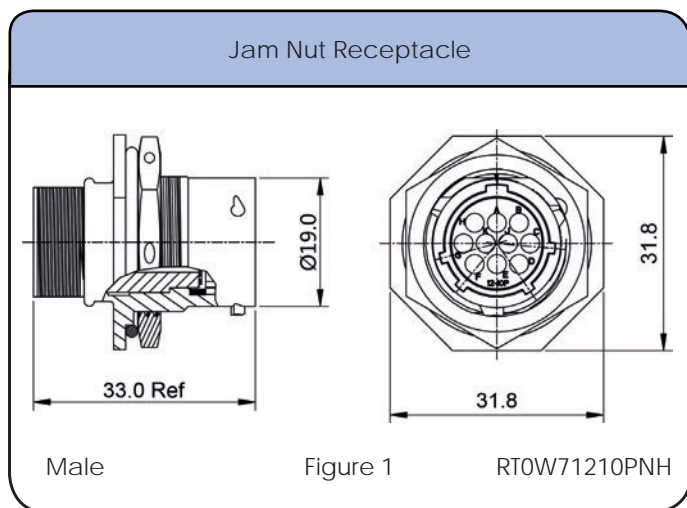

Shell Size: 12 Number of Contacts: 10 Contact Size: 20
Sealing: IP67 Salt Spray: 48h

Dimensions Plug

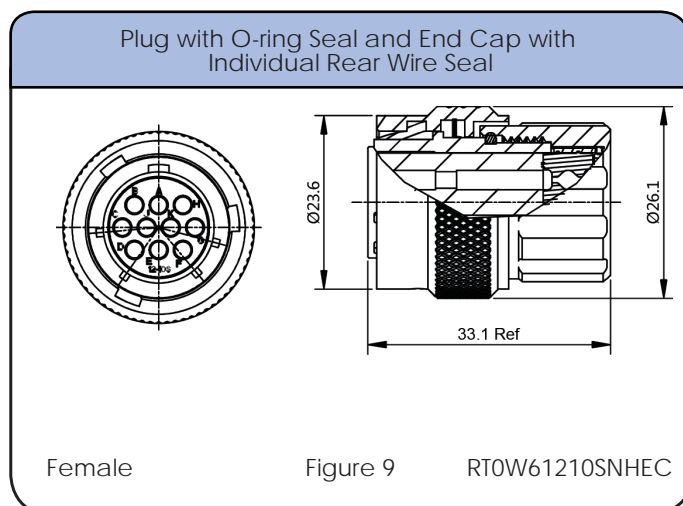
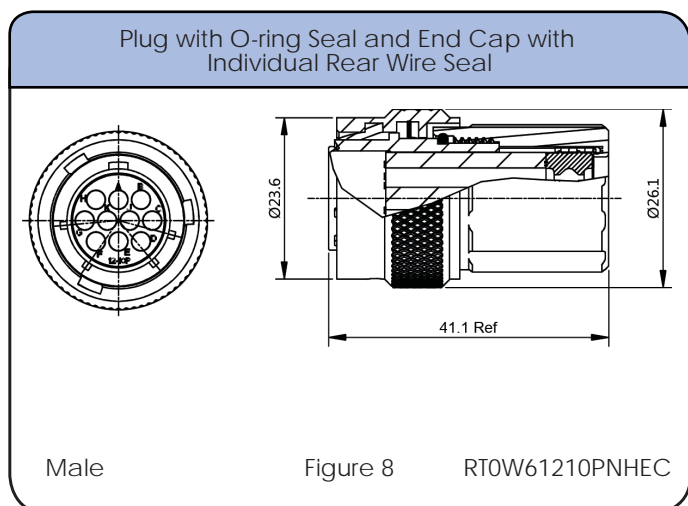
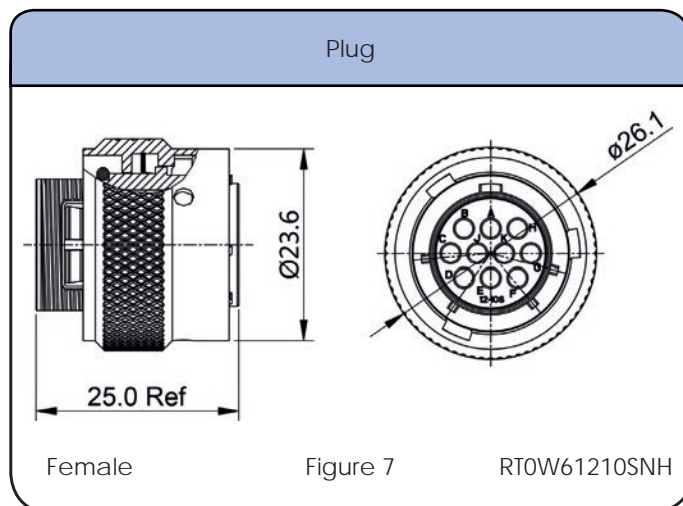
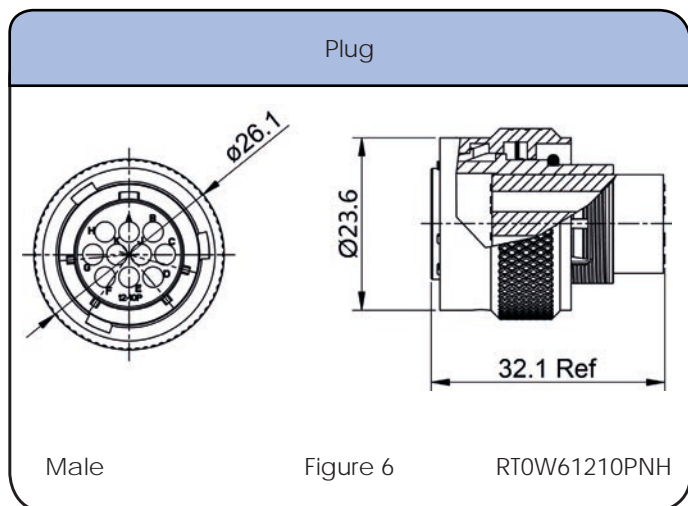

Individual Sealing Wire Range

Contact Size	Insulation Overall Diameter (min-max)	Wire Range
20	Ø1.6mm - Ø2.6mm	20 - 30 AWG

Shell Size: 12 Number of Contacts: 10 Contact Size: 20
 Sealing: IP67 Salt Spray: 48h

Dimensions Square Flange Receptacle

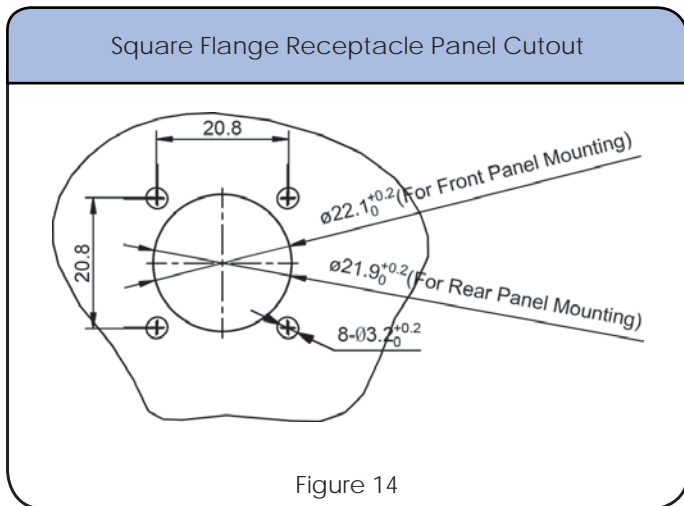
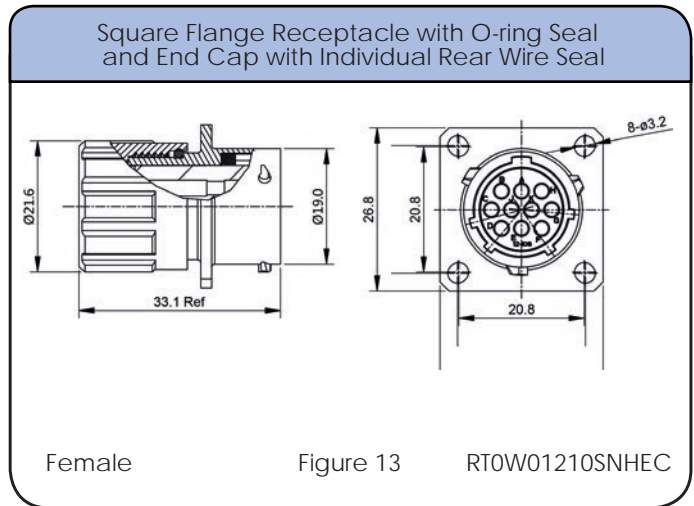
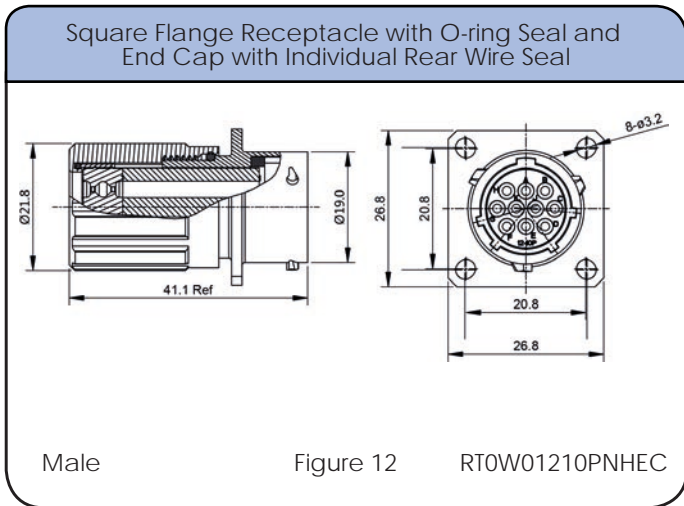
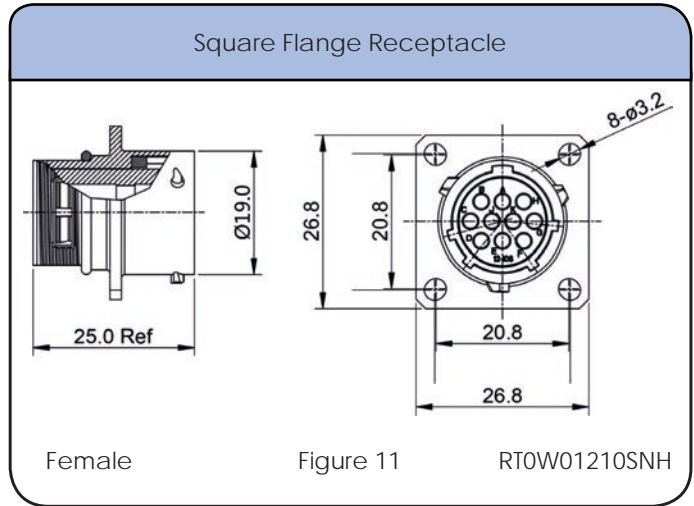
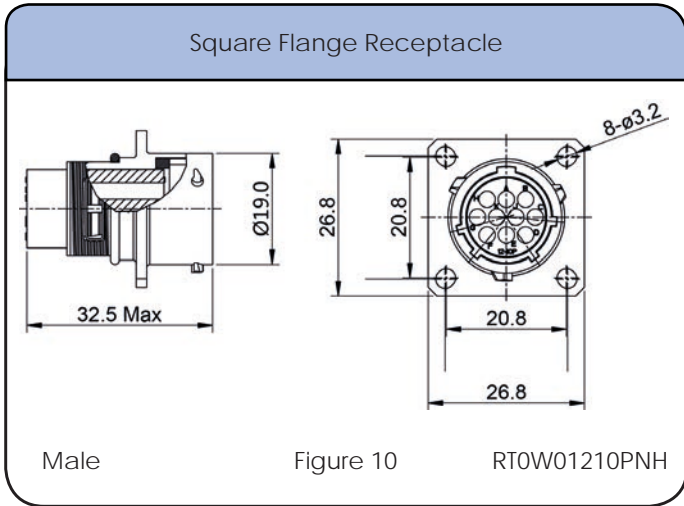

Shell Size: 12 Number of Contacts: 10 Contact Size: 20
Sealing: IP67 Salt Spray: 48h

Dimensions Backshell

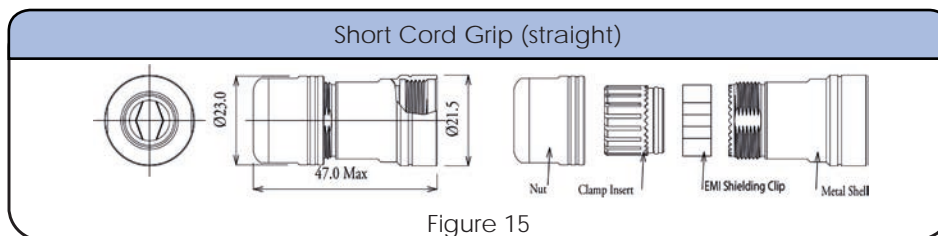

Figure 15

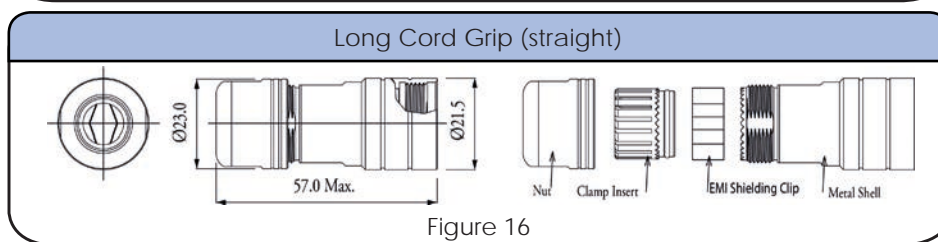

Figure 16

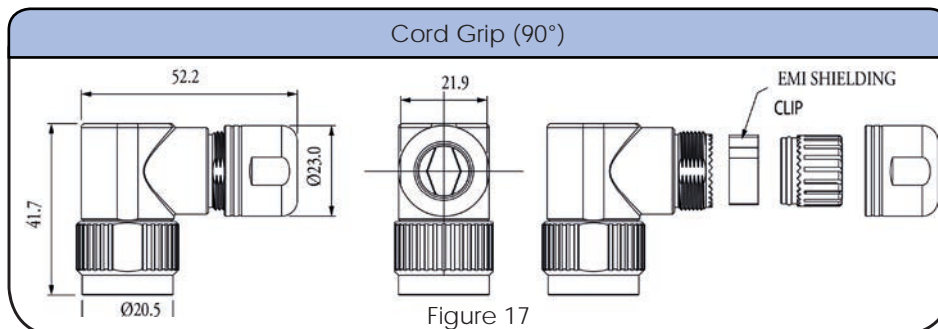











Figure 17

Accessories

<p>Locking Clip with Lanyard</p>  <p>NEW! See Page 16</p> <p>108039112</p>	<p>Plug Dustcap with Chain</p>  <p>RT612DCG</p>	<p>Plug Dustcap without Chain</p>  <p>RT612DC</p>	<p>Receptacle Dustcap with Chain</p>  <p>RT012DCG</p>
<p>Receptacle Dustcap with Nylon Cord, Made of Rubber</p>  <p>RT012RL</p>	<p>Receptacle Dustcap without Chain</p>  <p>RT012DC</p>	<p>Receptacle Dustcap without Nylon Cord, Rubber Material</p>  <p>RB00011912</p>	<p>Sealing Plug</p>  <p>CA402059</p>
<p>Square Flange Receptacle Gaskets, Thickness 0.8mm (±0.2)</p>  <p>RTFD12B</p>			

Shell Size: 12
Sealing: IP67

Number of Contacts: 10
Salt Spray: 48h

Contact Size: 20

Contacts



Crimp Contacts, Machined

Part Number		AWG	Wire Range (mm ²)	Plating
Male	Female			
MP20W23F	MS20W23F	22-20	.34-.50	Gold Flash
MP20W23G5	MS20W23G5	22-20	.34-.50	Gold 5μ"
MP20W23G10	MS20W23G10	22-20	.34-.50	Gold 10μ"
MP20W23G15	MS20W23G15	22-20	.34-.50	Gold 15μ"
MP20W23G30	MS20W23G30	22-20	.34-.50	Gold 30μ"
MP24W23F	MS24W23F	26-24	.13-.25	Gold Flash
MP24W23G5	MS24W23G5	26-24	.13-.25	Gold 5μ"
MP24W23G10	MS24W23G10	26-24	.13-.25	Gold 10μ"
MP24W23G15	MS24W23G15	26-24	.13-.25	Gold 15μ"
MP24W23G30	MS24W23G30	26-24	.13-.25	Gold 30μ"
MP28W23F	MS28W23F	30-28	.05-.08	Gold Flash
MP28W23G5	MS28W23G5	30-28	.05-.08	Gold 5μ"
MP28W23G10	MS28W23G10	30-28	.05-.08	Gold 10μ"
MP28W23G15	MS28W23G15	30-28	.05-.08	Gold 15μ"
MP28W23G30	MS28W23G30	30-28	.05-.08	Gold 30μ"

Tools



Shell Size: 12 Number of Contacts: 10 Contact Size: 20
Sealing: IP67 Salt Spray: 48h

Contacts (con't)



Crimp Contacts, Stamped & Formed

Part Number		AWG	Wire Range (mm ²)	Plating
Male	Female			
SP20W1F	SS20W1F	22-20	.34-.50	Gold Flash
SP20W1G5	SS20W1G5	22-20	.34-.50	Gold 5μ"
SP20W1G10	SS20W1G10	22-20	.34-.50	Gold 10μ"
SP20W1G15	SS20W1G15	22-20	.34-.50	Gold 15μ"
SP20W1G30	SS20W1G30	22-20	.34-.50	Gold 30μ"
SP24W1F	SS24W1F	26-24	.14-.25	Gold Flash
SP24W1G5	SS24W1G5	26-24	.14-.25	Gold 5μ"
SP24W1G10	SS24W1G10	26-24	.14-.25	Gold 10μ"
SP24W1G15	SS24W1G15	26-24	.14-.25	Gold 15μ"
SP24W1G30	SS24W1G30	26-24	.14-.25	Gold 30μ"
SP28W1F	SS28W1F	30-28	.05-.08	Gold Flash
SP28W1G5	SS28W1G5	30-28	.05-.08	Gold 5μ"
SP28W1G10	SS28W1G10	30-28	.05-.08	Gold 10μ"
SP28W1G15	SS28W1G15	30-28	.05-.08	Gold 15μ"
SP28W1G30	SS28W1G30	30-28	.05-.08	Gold 30μ"

Tools

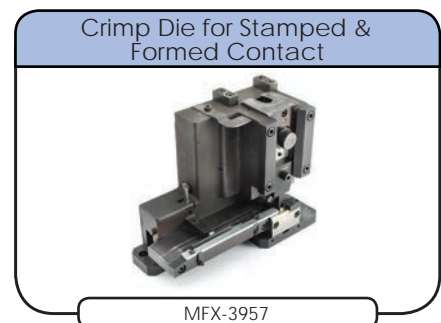

STEP 1
Choose Receptacle Style

STEP 2
Choose Plug Style

STEP 2
Choose Backshell Style

Jam Nut Receptacles



OR
Square Flange Receptacles



Jam Nut Receptacle Kit Including Receptacle & Contacts



Square Flange Receptacle Kit Including Receptacle, Gasket & Contacts



Plug



Backshell



OR
Plug Kit Including Connector, Backshell & Contacts



SEE TABLE ON NEXT PAGE FOR PART DETAILS

CONTACTS SOLD SEPARATELY SEE PAGE 124

Shell Size: 14 Number of Contacts: 12 Contact Size: 16
Sealing: IP67 Salt Spray: 48h

eco | mate[®] rm
Standard Products

- Suitable For Indoor and Outdoor Applications
- EMI/RMI Shielding Capability with Appropriate Backshell
- Operating Temperature: -40°C to +105°C
- 500 Mating Cycles
- Contacts and Cord Grips Ordered Separately
- UL ECBT2 Certified*

An upgraded silicone seal is available for all connector parts. Please add "03" to the end of the part number when ordering. Operating Temperature: -40°C to +125°C. Not available in kits.

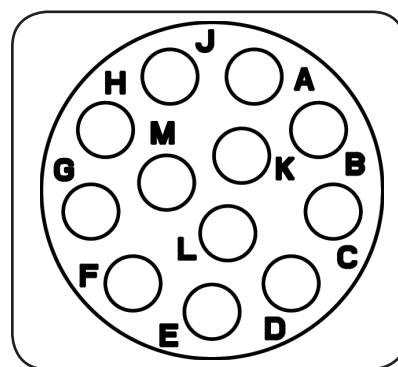

Insert Arrangement
Pin (Male) Faceview

Connector Part Numbers

Part Number		Connector Type	Figure Drawings	
Male	Female		Male	Female
RT071412PNH	RT071412SNH	Jam Nut Receptacle	1,5	2,5
RT071412PNHEC	RT071412SNHEC	Jam Nut Receptacle with O-ring Seal and End Cap with Individual Rear Wire Seal**	3,5	4,5
RT071412PNHK	RT071412SNHK	Jam Nut Receptacle Kit	1,5	2,5
RT061412PNH	RT061412SNH	Plug	6	7
RT061412PNHEC	RT061412SNHEC	Plug with O-ring Seal and End Cap with Individual Rear Wire Seal**	8	9
RT061412PNHK	RT061412SNHK	Plug Kit	6	7
RT001412PNH	RT001412SNH	Square Flange Receptacle	10,14	11,14
RT001412PNHEC	RT001412SNHEC	Square Flange Receptacle with O-ring Seal and End Cap with Individual Rear Wire Seal**	12,14	13,14
RT001412PNHK	RT001412SNHK	Square Flange Receptacle Kit	10,14	11,14

Contacts supplied separately see page 124

**See page 121 for the real seal wire range

Backshells

Part Number	Backshell Type	Cable Range (mm)	Figure Drawings	Shielding
RTOS14CGNS1	Short Cord Grip (straight)	6-10.5	15	✓
RTOS14CGNS2	Short Cord Grip (straight)	8.5-12.5	15	✓
RTOL14CGNS1	Long Cord Grip (straight)	6-10.5	16	✓
RTOL14CGNS2	Long Cord Grip (straight)	8.5-12.5	16	✓
RTOB14CGNS1	Cord Grip (90°)	6-10.5	17	✓
RTOB14CGNS2	Cord Grip (90°)	8.0-12.5	17	✓

*Connector parts with part numbers ending in EC (with an end cap) were not available for submittal at the time of UL certification.

Shell Size: 14 Number of Contacts: 12
 Sealing: IP67 Salt Spray: 48h

Contact Size: 16

Dimensions Jam Nut Receptacle

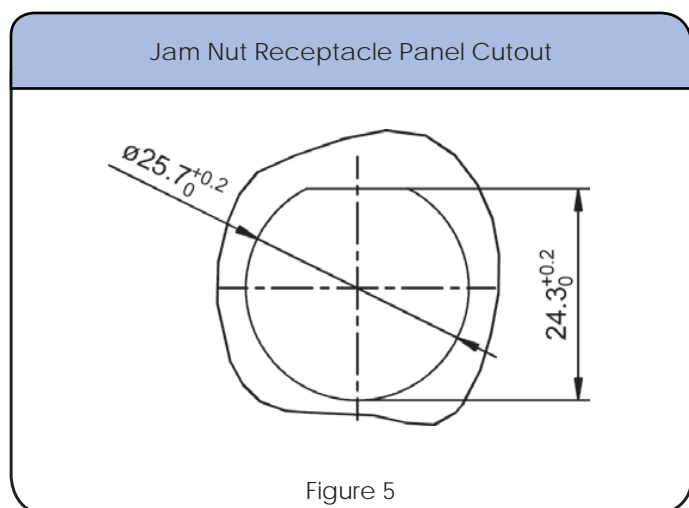
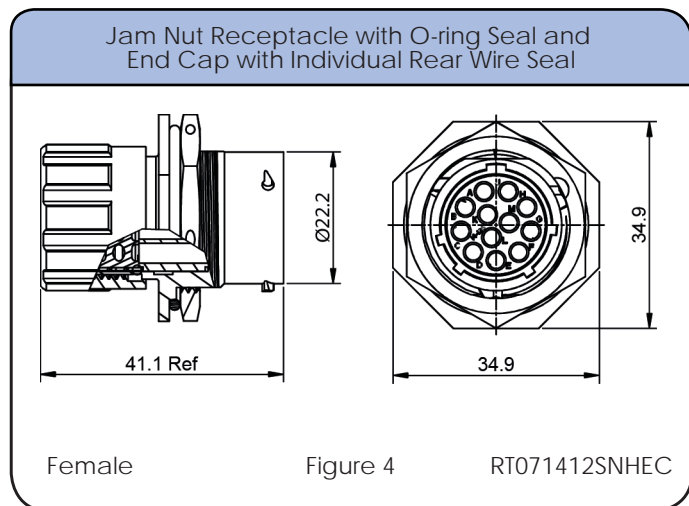
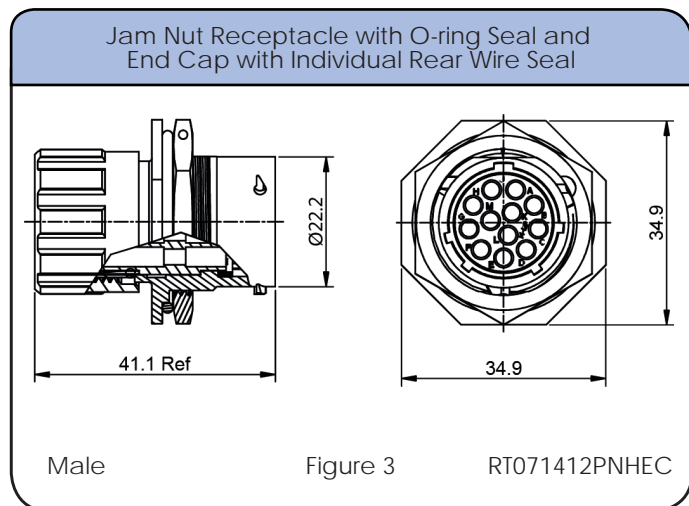
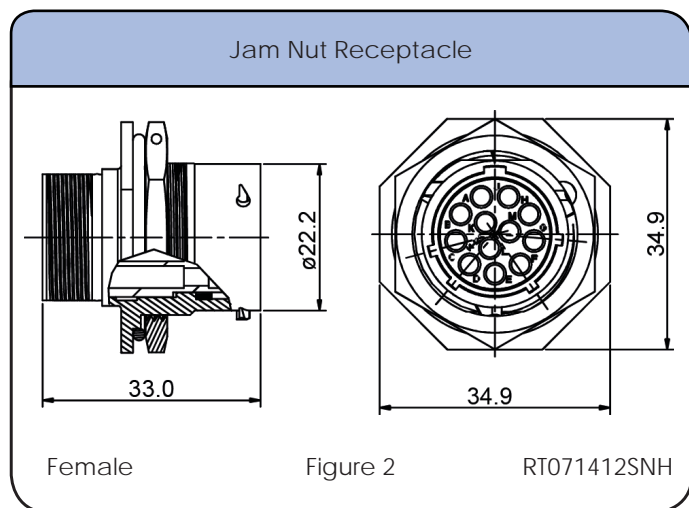
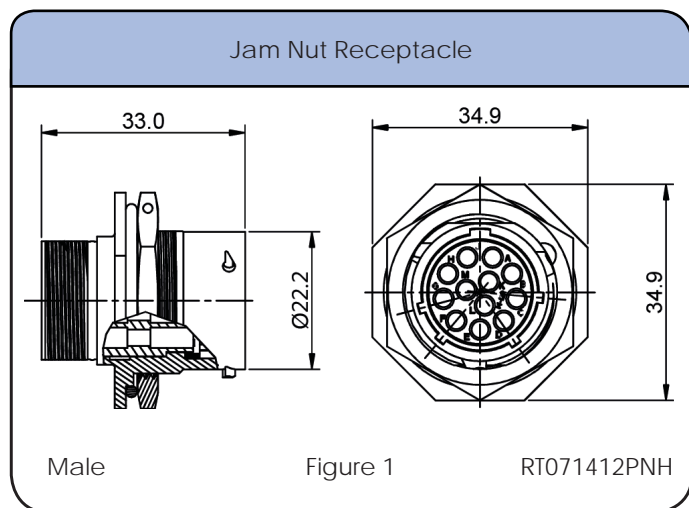

Shell Size: 14 Number of Contacts: 12 Contact Size: 16
Sealing: IP67 Salt Spray: 48h

Dimensions Plug

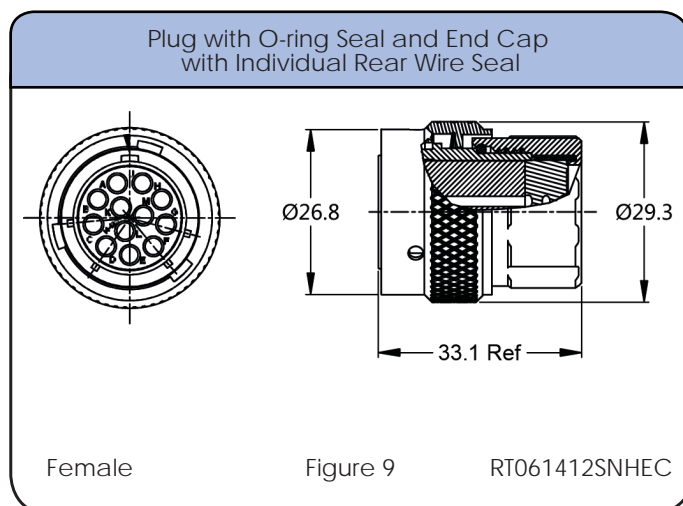
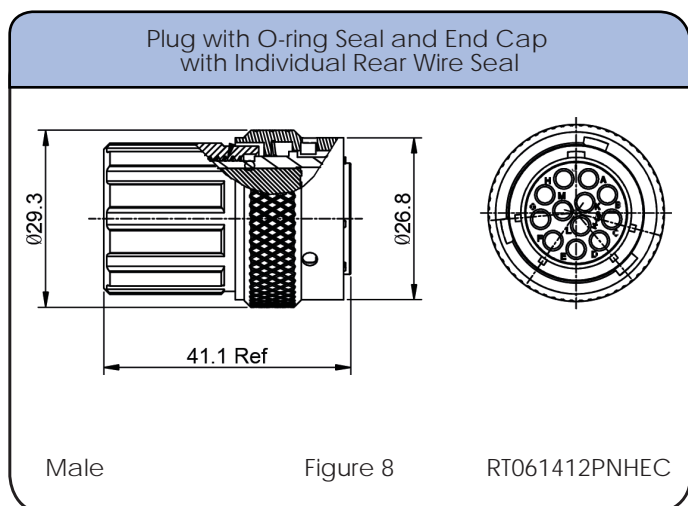
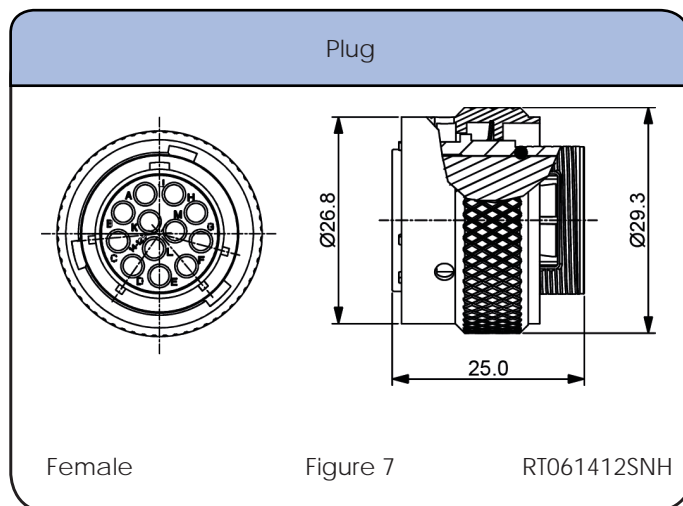
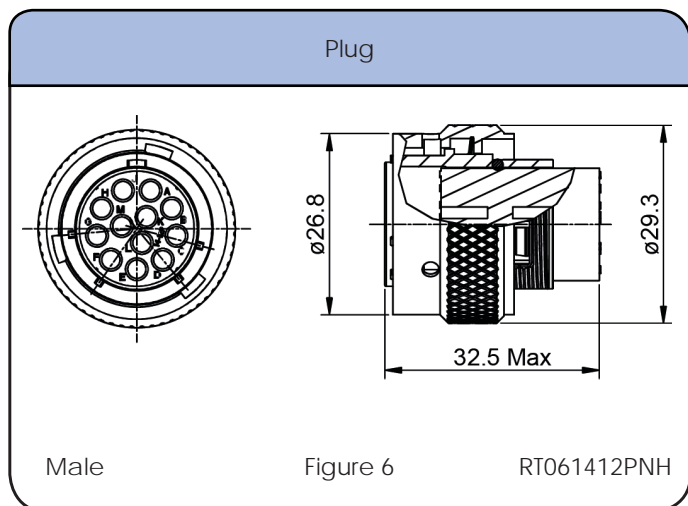

Individual Sealing Wire Range

Contact Size	Insulation Overall Diameter (min-max)	Wire Range
16	Ø2.0mm - Ø3.2mm	14 - 24 AWG

Shell Size: 14 Number of Contacts: 12 Contact Size: 16
 Sealing: IP67 Salt Spray: 48h

Dimensions Square Flange Receptacle

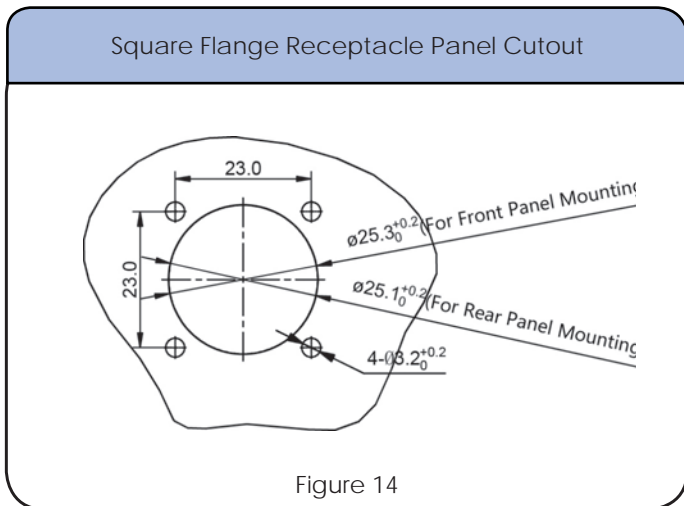
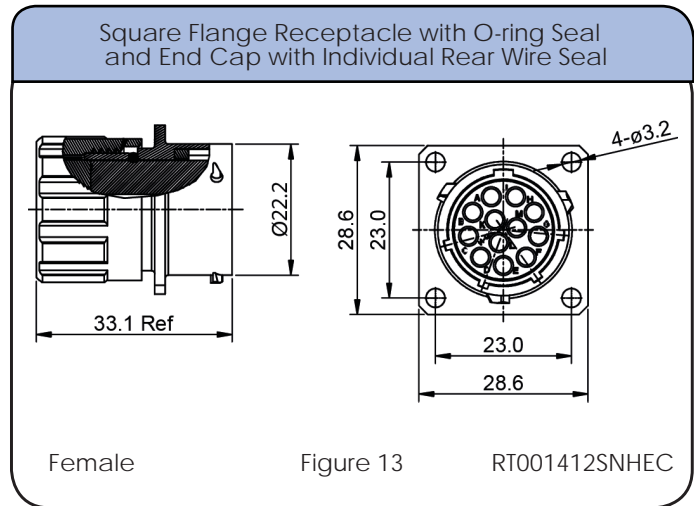
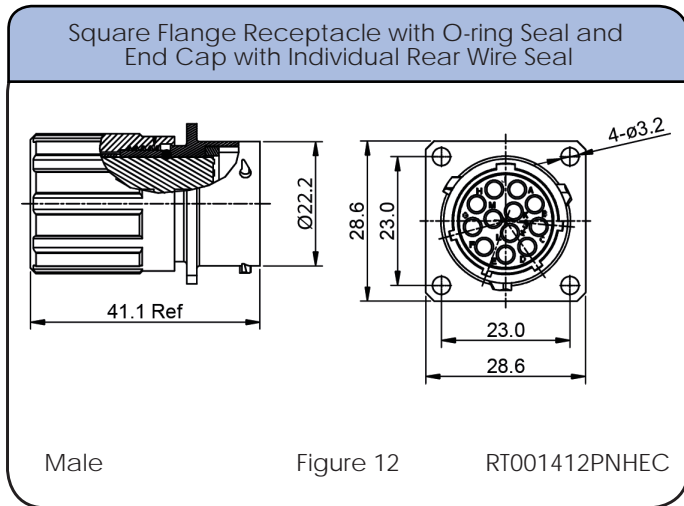
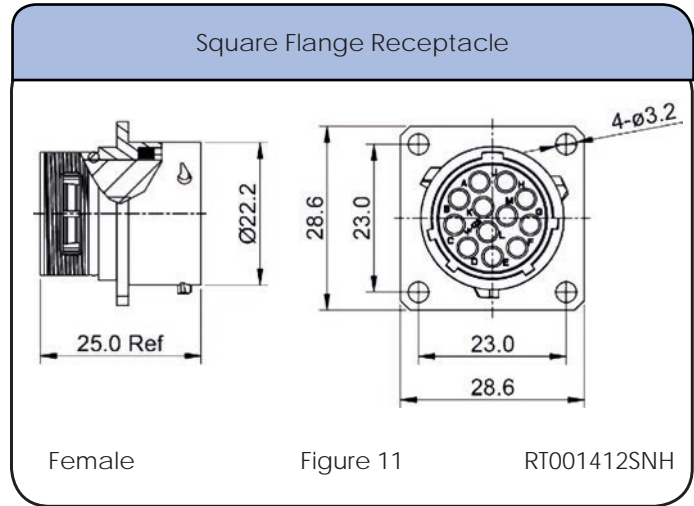
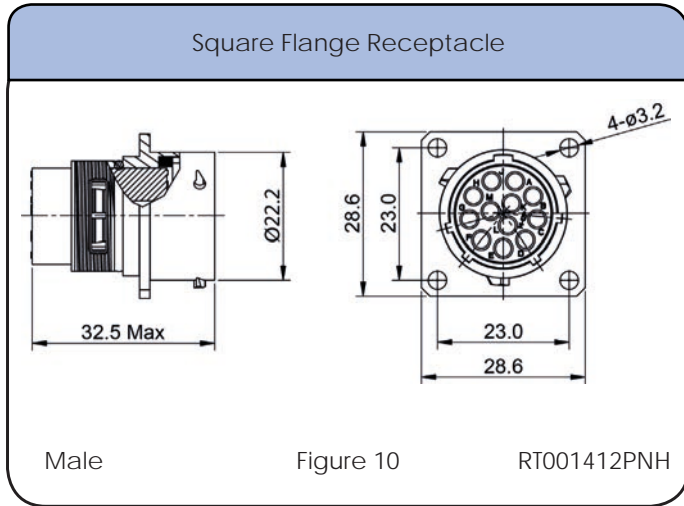

Shell Size: 14 Number of Contacts: 12 Contact Size: 16
Sealing: IP67 Salt Spray: 48h

Dimensions Backshell

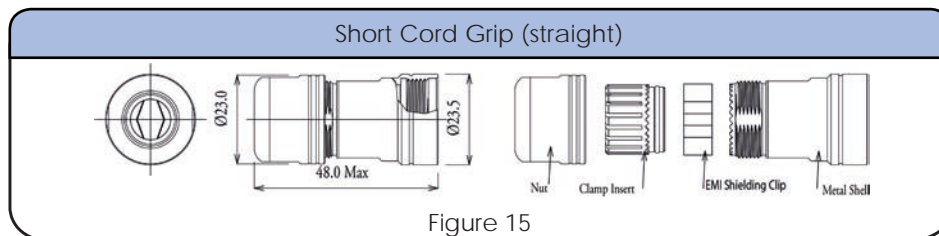

Figure 15

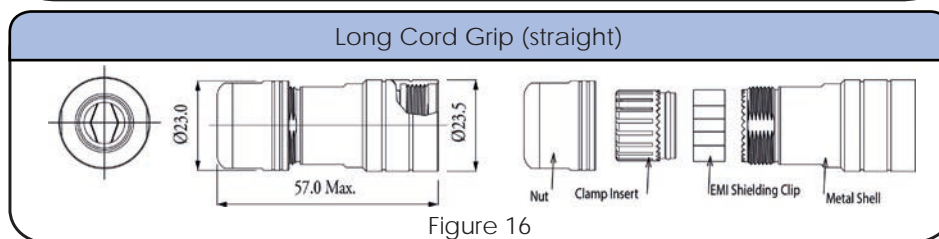

Figure 16

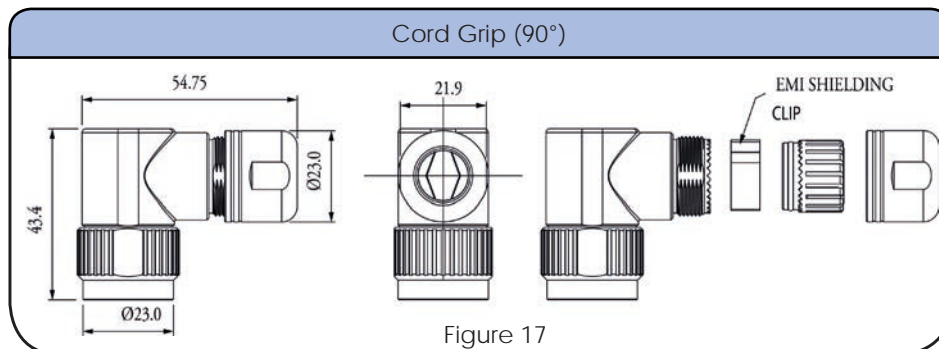











Figure 17

Accessories

<p>Locking Clip with Lanyard</p>  <p>108039114</p>	<p>Plug Dustcap with Chain</p>  <p>RT614DCG</p>	<p>Plug Dustcap without Chain</p>  <p>RT614DC</p>	<p>Receptacle Dustcap with Chain</p>  <p>RT014DCG</p>
<p>Receptacle Dustcap with Nylon Cord, Made of Rubber</p>  <p>RT014RL</p>	<p>Receptacle Dustcap without Chain</p>  <p>RT014DC</p>	<p>Receptacle Dustcap without Nylon Cord, Rubber Material</p>  <p>RB00011914</p>	<p>Sealing Plug</p>  <p>CA401659</p>
<p>Square Flange Receptacle Gaskets, Thickness 0.8mm (±0.2)</p>  <p>RTFD14B</p>			

NEW!
See
Page
16

Shell Size: 14
Sealing: IP67

Number of Contacts: 12
Salt Spray: 48h

Contact Size: 16

Contacts



Crimp Contacts, Machined

Part Number		AWG	Wire Range (mm ²)	Plating
Male	Female			
MP14M23F	MS14M23F	14	2.0-2.5	Gold Flash
MP14M23G5	MS14M23G5	14	2.0-2.5	Gold 5μ"
MP14M23G10	MS14M23G10	14	2.0-2.5	Gold 10μ"
MP14M23G15	MS14M23G15	14	2.0-2.5	Gold 15μ"
MP14M23G30	MS14M23G30	14	2.0-2.5	Gold 30μ"
MP16M23F	MS16M23F	18-16	.75-1.5	Gold Flash
MP16M23G5	MS16M23G5	18-16	.75-1.5	Gold 5μ"
MP16M23G10	MS16M23G10	18-16	.75-1.5	Gold 10μ"
MP16M23G15	MS16M23G15	18-16	.75-1.5	Gold 15μ"
MP16M23G30	MS16M23G30	18-16	.75-1.5	Gold 30μ"
MP20M23F	MS20M23F	22-20	.34-.50	Gold Flash
MP20M23G5	MS20M23G5	22-20	.34-.50	Gold 5μ"
MP20M23G10	MS20M23G10	22-20	.34-.50	Gold 10μ"
MP20M23G15	MS20M23G15	22-20	.34-.50	Gold 15μ"
MP20M23G30	MS20M23G30	22-20	.34-.50	Gold 30μ"
MP24M23F	MS24M23F	26-24	.14-.25	Gold Flash
MP24M23G5	MS24M23G5	26-24	.14-.25	Gold 5μ"
MP24M23G10	MS24M23G10	26-24	.14-.25	Gold 10μ"
MP24M23G15	MS24M23G15	26-24	.14-.25	Gold 15μ"
MP24M23G30	MS24M23G30	26-24	.14-.25	Gold 30μ"

Tools



Shell Size: 14 Number of Contacts: 12 Contact Size: 16
Sealing: IP67 Salt Spray: 48h

Contacts (con't)



Stamped & Formed Contacts

Crimp Contacts, Stamped & Formed

Part Number		AWG	Wire Range (mm ²)	Plating
Male	Female			
SP14M1F	SS14M1F	14	2.0-2.5	Gold Flash
SP14M1G5	SS14M1G5	14	2.0-2.5	Gold 5μ"
SP14M1G10	SS14M1G10	14	2.0-2.5	Gold 10μ"
SP14M1G15	SS14M1G15	14	2.0-2.5	Gold 15μ"
SP14M1G30	SS14M1G30	14	2.0-2.5	Gold 30μ"
SP16M1F	SS16M1F	18-16	.75-1.5	Gold Flash
SP16M1G5	SS16M1G5	18-16	.75-1.5	Gold 5μ"
SP16M1G10	SS16M1G10	18-16	.75-1.5	Gold 10μ"
SP16M1G15	SS16M1G15	18-16	.75-1.5	Gold 15μ"
SP16M1G30	SS16M1G30	18-16	.75-1.5	Gold 30μ"
SP20M1F	SS20M1F	22-20	.34-.50	Gold Flash
SP20M1G5	SS20M1G5	22-20	.34-.50	Gold 5μ"
SP20M1G10	SS20M1G10	22-20	.34-.50	Gold 10μ"
SP20M1G15	SS20M1G15	22-20	.34-.50	Gold 15μ"
SP20M1G30	SS20M1G30	22-20	.34-.50	Gold 30μ"
SP24M1F	SS24M1F	22-20	.14-.25	Gold Flash
SP24M1G5	SS24M1G5	26-24	.14-.25	Gold 5μ"
SP24M1G10	SS24M1G10	26-24	.14-.25	Gold 10μ"
SP24M1G15	SS24M1G15	26-24	.14-.25	Gold 15μ"
SP24M1G30	SS24M1G30	26-24	.14-.25	Gold 30μ"

Tools



Contact Extraction Tool, #16 (Ø 1.6) Contact

QXRT16



Hand Tool, Stamped & Formed Contact, Size 16, 20-14AWG

MFX-3954



Crimp Die for Stamped & Formed Contact

MFX-3957

STEP 1
Choose Receptacle Style

STEP 2
Choose Plug Style

STEP 2
Choose Backshell Style

Jam Nut Receptacles



OR
Square Flange Receptacles



Jam Nut Receptacle Kit Including Receptacle & Contacts



Square Flange Receptacle Kit Including Receptacle, Gasket & Contacts



Plug



Backshell



OR
Plug Kit Including Connector, Backshell & Contacts



SEE TABLE ON NEXT PAGE FOR PART DETAILS

CONTACTS SOLD SEPARATELY SEE PAGE 132

Shell Size: 14 Number of Contacts: 19 Contact Size: 20
Sealing: IP67 Salt Spray: 48h

eco | mate[®] rm Standard Products

- Suitable For Indoor and Outdoor Applications
- EMI/RMI Shielding Capability with Appropriate Backshell
- Operating Temperature: -40°C to +105°C
- 500 Mating Cycles
- Contacts and Cord Grips Ordered Separately
- UL ECBT2 Certified*

An upgraded silicone seal is available for all connector parts. Please add "03" to the end of the part number when ordering. Operating Temperature: -40°C to +125°C. Not available in kits.

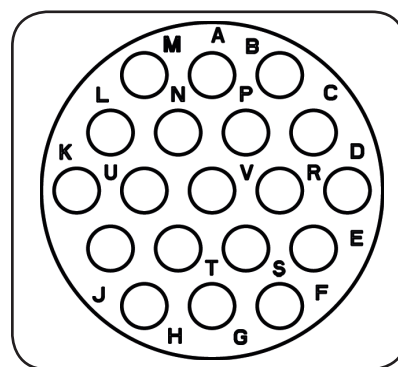

Insert Arrangement
Pin (Male) Faceview

Connector Part Numbers

Part Number		Connector Type	Figure Drawings	
Male	Female		Male	Female
RTOW71419PNH	RTOW71419SNH	Jam Nut Receptacle	1,5	2,5
RTOW71419PNHEC	RTOW71419SNHEC	Jam Nut Receptacle with O-ring Seal and End Cap with Individual Rear Wire Seal**	3,5	4,5
RTOW71419PNHK	RTOW71419SNHK	Jam Nut Receptacle Kit	1,5	2,5
RTOW61419PNH	RTOW61419SNH	Plug	6	7
RTOW61419PNHEC	RTOW61419SNHEC	Plug with O-ring Seal and End Cap with Individual Rear Wire Seal**	8	9
RTOW61419PNHK	RTOW61419SNHK	Plug Kit	1,5	2,5
RTOW01419PNH	RTOW01419SNH	Square Flange Receptacle	10,14	11,14
RTOW01419PNHEC	RTOW01419SNHEC	Square Flange Receptacle with O-ring Seal and End Cap with Individual Rear Wire Seal**	12,14	13,14
RTOW01419PNHK	RTOW01419SNHK	Square Flange Receptacle Kit	10,14	11,14

Contacts supplied separately see page 132

**See page 129 for the real seal wire range

Backshells

Part Number	Backshell Type	Cable Range (mm)	Figure Drawings	Shielding
RT0S14CGNS1	Short Cord Grip (straight)	6-10.5	15	✓
RT0S14CGNS2	Short Cord Grip (straight)	8.5-12.5	15	✓
RT0L14CGNS1	Long Cord Grip (straight)	6-10.5	16	✓
RT0L14CGNS2	Long Cord Grip (straight)	8.5-12.5	16	✓
RT0B14CGNS1	Cord Grip (90°)	6-10.5	17	✓
RT0B14CGNS2	Cord Grip (90°)	8.0-12.5	17	✓

*Connector parts with part numbers ending in EC (with an end cap) were not available for submittal at the time of UL certification.

Shell Size: 14 Number of Contacts: 19
 Sealing: IP67 Salt Spray: 48h

Contact Size: 20

Dimensions Jam Nut Receptacle

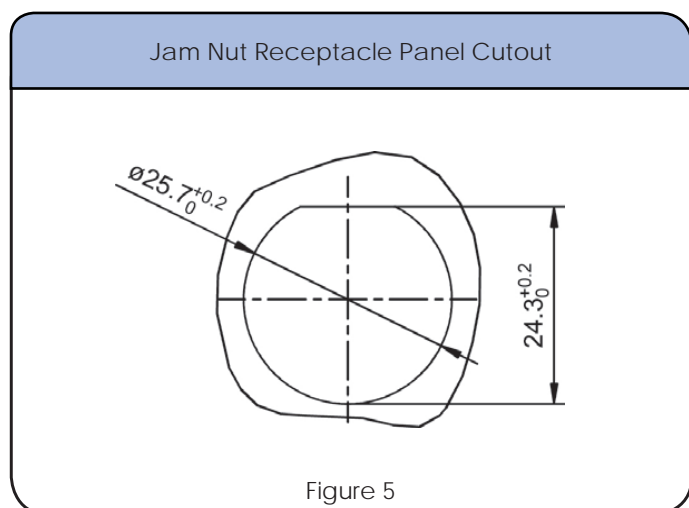
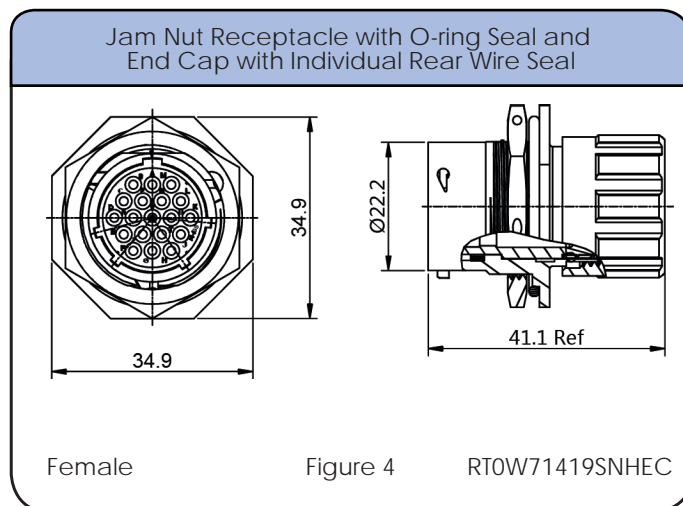
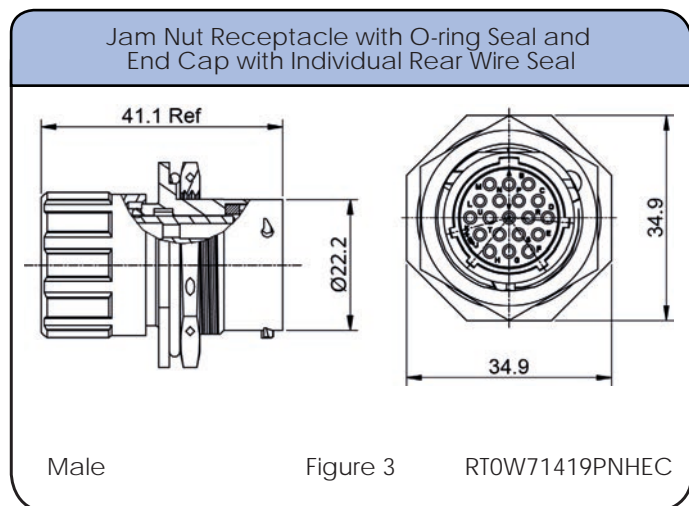
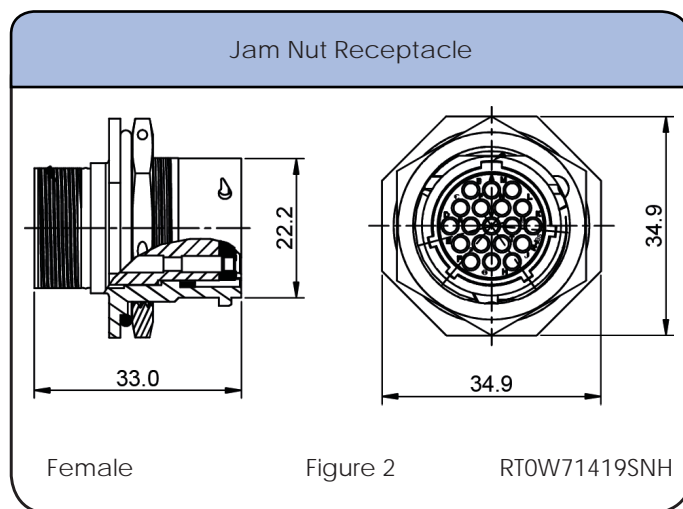
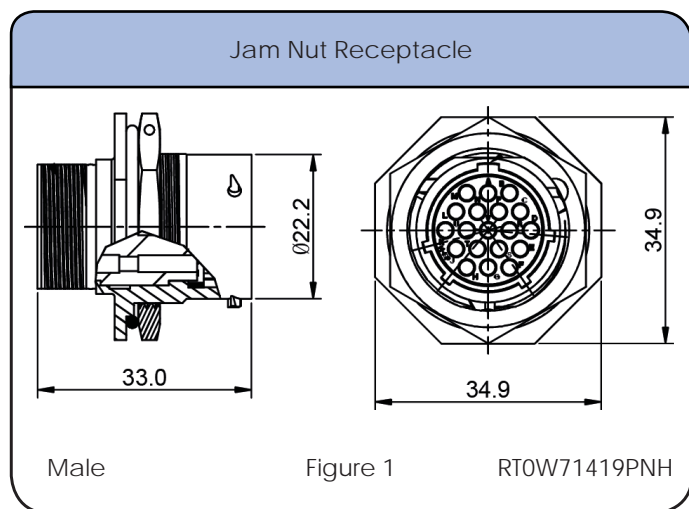

Shell Size: 14 Number of Contacts: 19
Sealing: IP67 Salt Spray: 48h

Contact Size: 20

Dimensions Plug

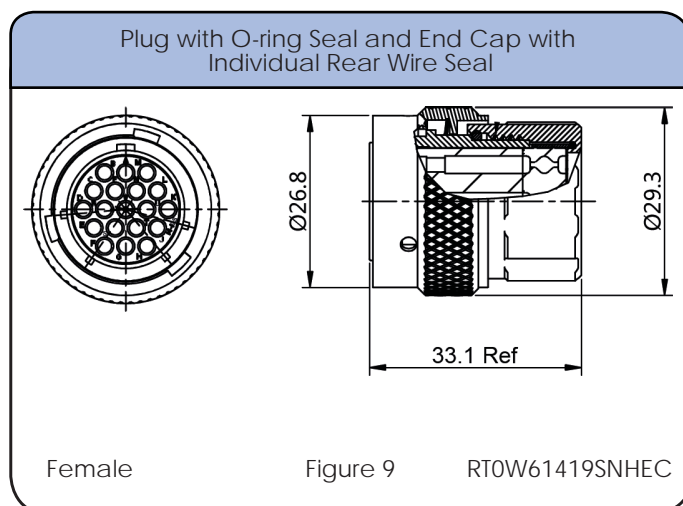
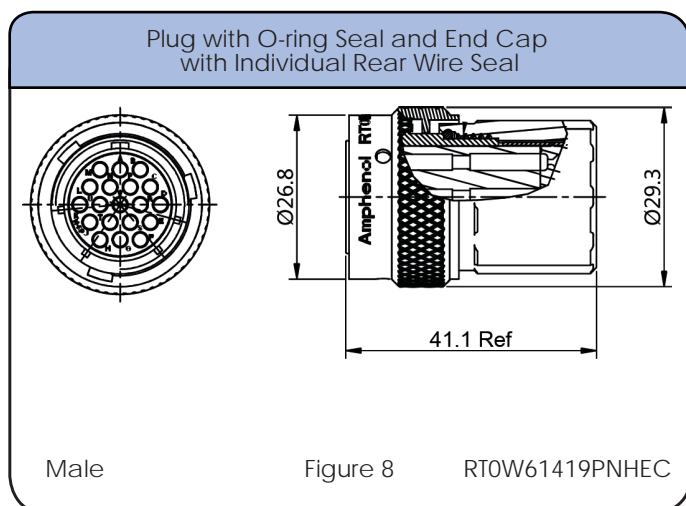
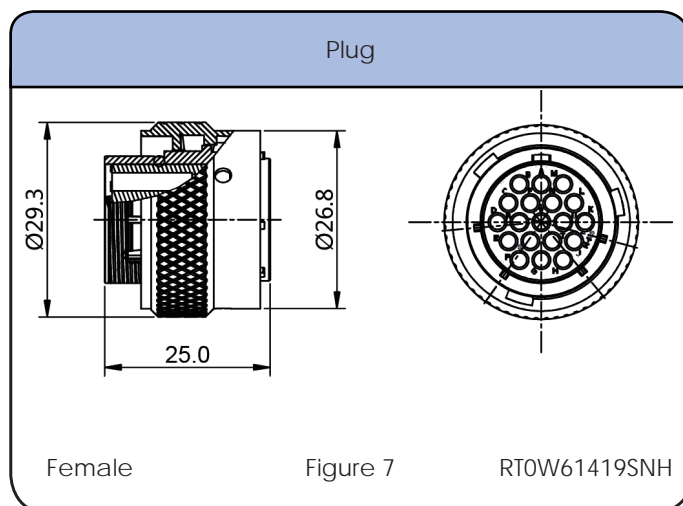
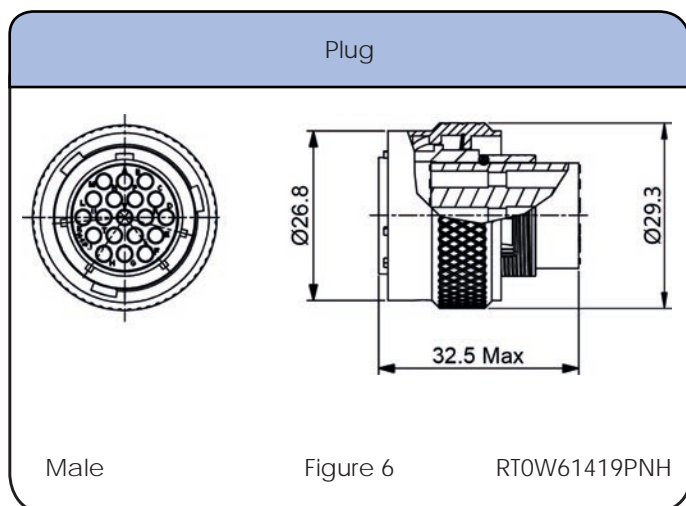

Individual Sealing Wire Range

Contact Size	Insulation Overall Diameter (min-max)	Wire Range
20	Ø1.6mm - Ø2.6mm	20 - 30 AWG

Shell Size: 14 Number of Contacts: 19 Contact Size: 20
 Sealing: IP67 Salt Spray: 48h

Dimensions Square Flange Receptacle

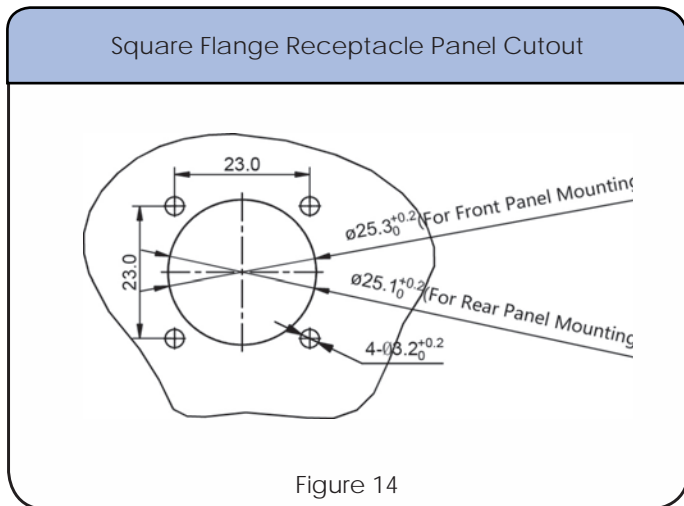
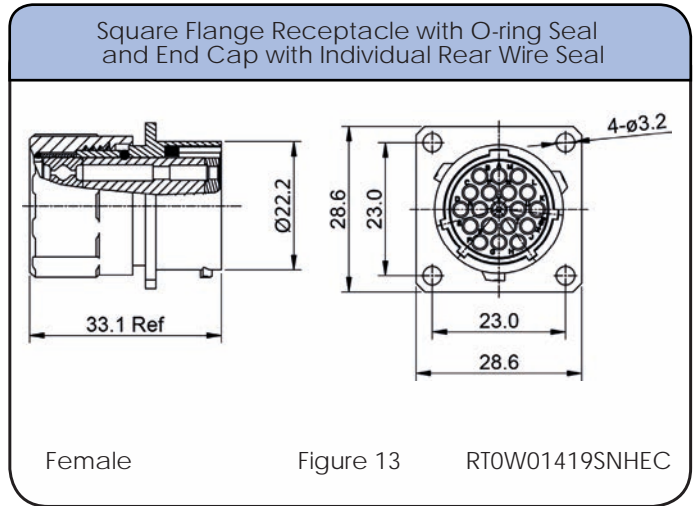
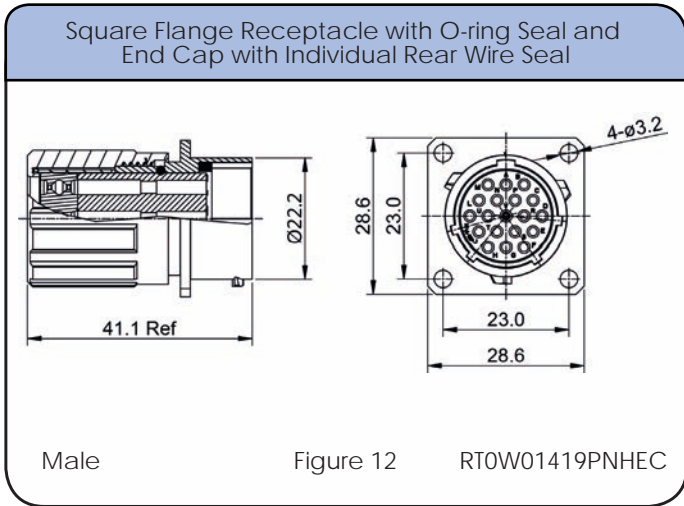
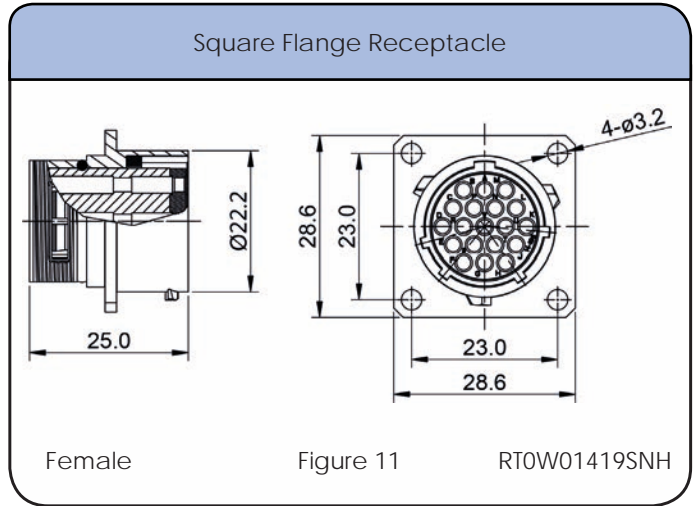
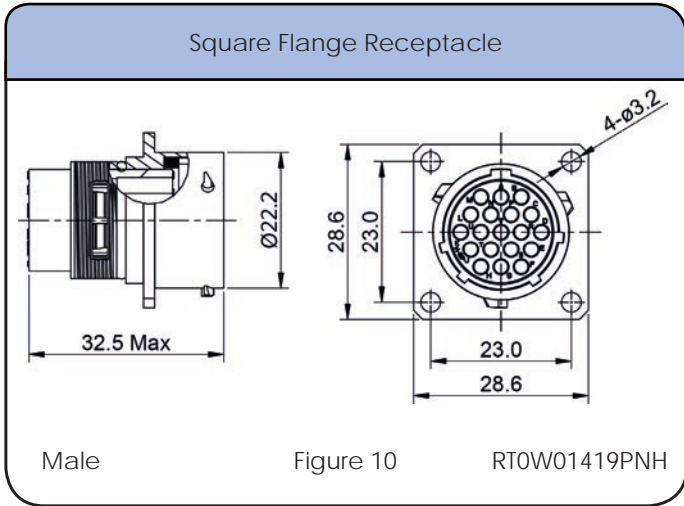

Shell Size: 14 Number of Contacts: 19 Contact Size: 20
Sealing: IP67 Salt Spray: 48h

Dimensions Backshell

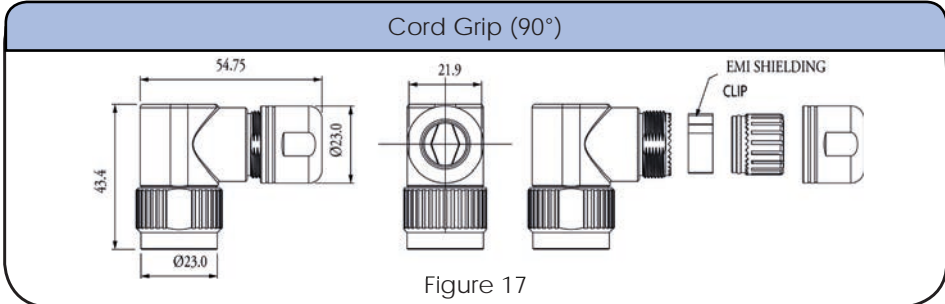
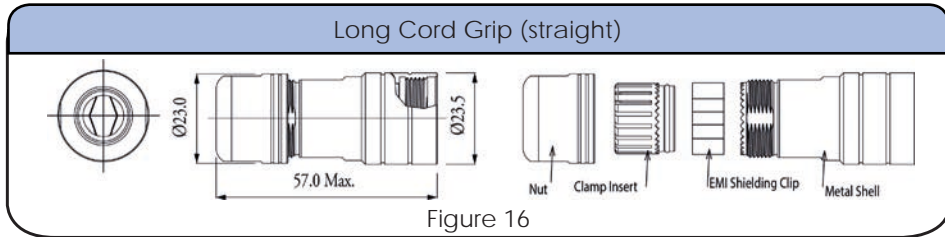
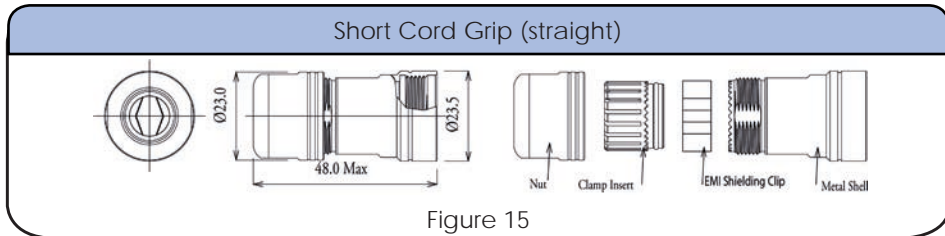

Accessories

<p>Locking Clip with Lanyard</p> <p>108039114</p>	<p>Plug Dustcap with Chain</p> <p>RT614DCG</p>	<p>Plug Dustcap without Chain</p> <p>RT614DC</p>	<p>Receptacle Dustcap with Chain</p> <p>RT014DCG</p>
<p>Receptacle Dustcap with Nylon Cord, Made of Rubber</p> <p>RT014RL</p>	<p>Receptacle Dustcap without Chain</p> <p>RT014DC</p>	<p>Receptacle Dustcap without Nylon Cord, Rubber Material</p> <p>RB00011914</p>	<p>Sealing Plug</p> <p>CA402059</p>
<p>Square Flange Receptacle Gaskets, Thickness 0.8mm (±0.2)</p> <p>RTFD14B</p>			

NEW!
See
Page
16

Shell Size: 14
Sealing: IP67

Number of Contacts: 19
Salt Spray: 48h

Contact Size: 20

Contacts



Crimp Contacts, Machined (7.5A Max)

Part Number		AWG	Wire Range (mm ²)	Plating
Male	Female			
MP20W23F	MS20W23F	22-20	.34-.50	Gold Flash
MP20W23G5	MS20W23G5	22-20	.34-.50	Gold 5μ"
MP20W23G10	MS20W23G10	22-20	.34-.50	Gold 10μ"
MP20W23G15	MS20W23G15	22-20	.34-.50	Gold 15μ"
MP20W23G30	MS20W23G30	22-20	.34-.50	Gold 30μ"
MP24W23F	MS24W23F	26-24	.13-.25	Gold Flash
MP24W23G5	MS24W23G5	26-24	.13-.25	Gold 5μ"
MP24W23G10	MS24W23G10	26-24	.13-.25	Gold 10μ"
MP24W23G15	MS24W23G15	26-24	.13-.25	Gold 15μ"
MP24W23G30	MS24W23G30	26-24	.13-.25	Gold 30μ"
MP28W23F	MS28W23F	30-28	.05-.08	Gold Flash
MP28W23G5	MS28W23G5	30-28	.05-.08	Gold 5μ"
MP28W23G10	MS28W23G10	30-28	.05-.08	Gold 10μ"
MP28W23G15	MS28W23G15	30-28	.05-.08	Gold 15μ"
MP28W23G30	MS28W23G30	30-28	.05-.08	Gold 30μ"

Tools



Shell Size: 14 Number of Contacts: 19 Contact Size: 20
Sealing: IP67 Salt Spray: 48h

Contacts (con't)



Stamped & Formed Contacts

Crimp Contacts, Stamped & Formed (5A Max)

Part Number		AWG	Wire Range (mm ²)	Plating
Male	Female			
SP20W1F	SS20W1F	22-20	.34-.50	Gold Flash
SP20W1G5	SS20W1G5	22-20	.34-.50	Gold 5μ"
SP20W1G10	SS20W1G10	22-20	.34-.50	Gold 10μ"
SP20W1G15	SS20W1G15	22-20	.34-.50	Gold 15μ"
SP20W1G30	SS20W1G30	22-20	.34-.50	Gold 30μ"
SP24W1F	SS24W1F	26-24	.14-.25	Gold Flash
SP24W1G5	SS24W1G5	26-24	.14-.25	Gold 5μ"
SP24W1G10	SS24W1G10	26-24	.14-.25	Gold 10μ"
SP24W1G15	SS24W1G15	26-24	.14-.25	Gold 15μ"
SP24W1G30	SS24W1G30	26-24	.14-.25	Gold 30μ"
SP28W1F	SS28W1F	30-28	.05-.08	Gold Flash
SP28W1G5	SS28W1G5	30-28	.05-.08	Gold 5μ"
SP28W1G10	SS28W1G10	30-28	.05-.08	Gold 10μ"
SP28W1G15	SS28W1G15	30-28	.05-.08	Gold 15μ"
SP28W1G30	SS28W1G30	30-28	.05-.08	Gold 30μ"

Tools



Contact Extraction Tool,
#20 (Ø 1.0) Contact

OXRT20



Hand Tool, Stamped &
Formed Contact, Size 20,
20-28AWG

MFX-3958



Crimp Die for Stamped &
Formed Contact

MFX-3957

STEP 1
Choose Receptacle Style

STEP 2
Choose Plug Style

STEP 2
Choose Backshell Style

Jam Nut Receptacles



OR
Square Flange Receptacles



Jam Nut Receptacle Kit Including Receptacle & Contacts



Square Flange Receptacle Kit Including Receptacle, Gasket & Contacts



Plug



Backshell



OR
Plug Kit Including Connector, Backshell & Contacts



SEE TABLE ON NEXT PAGE FOR PART DETAILS

CONTACTS SOLD SEPARATELY SEE PAGE 140

Shell Size: 16 Number of Contacts: 19 Contact Size: 16
Sealing: IP67 Salt Spray: 48h

eco | mate[®] rm
Standard Products

- Suitable For Indoor and Outdoor Applications
- EMI/RMI Shielding Capability with Appropriate Backshell
- Operating Temperature: -40°C to +105°C
- 500 Mating Cycles
- Contacts and Cord Grips Ordered Separately
- UL ECBT2 Certified*

An upgraded silicone seal is available for all connector parts. Please add "03" to the end of the part number when ordering. Operating Temperature: -40°C to +125°C. Not available in kits.

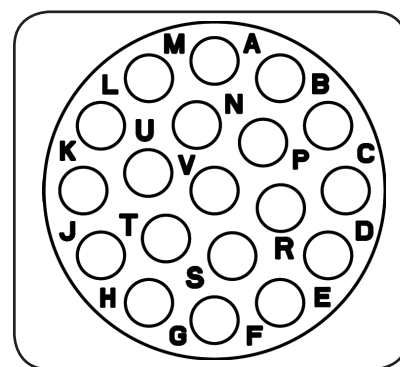

Insert Arrangement
Pin (Male) Faceview

Connector Part Numbers

Part Number		Connector Type	Figure Drawings	
Male	Female		Male	Female
RT071619PNH	RT071619SNH	Jam Nut Receptacle	1,5	2,5
RT071619PNHEC	RT071619SNHEC	Jam Nut Receptacle with O-ring Seal and End Cap with Individual Rear Wire Seal**	3,5	4,5
RT071619PNHK	RT071619SNHK	Jam Nut Receptacle Kit	1,5	2,5
RT061619PNH	RT061619SNH	Plug	6	7
RT061619PNHEC	RT061619SNHEC	Plug with O-ring Seal and End Cap with Individual Rear Wire Seal**	8	9
RT061619PNHK	RT061619SNHK	Plug Kit	6	7
RT001619PNH	RT001619SNH	Square Flange Receptacle	10,14	11,14
RT001619PNHEC	RT001619SNHEC	Square Flange Receptacle with O-ring Seal and End Cap with Individual Rear Wire Seal**	12,14	13,14
RT001619PNHK	RT001619SNHK	Square Flange Receptacle Kit	10,14	11,14

Contacts supplied separately see page 140

**See page 137 for the real seal wire range

Backshells

Part Number	Backshell Type	Cable Range (mm)	Figure Drawings	Shielding
RTOS16CGNS1	Short Cord Grip (straight)	9.0-14.5	15	✓
RTOS16CGNS2	Short Cord Grip (straight)	13.5-17	15	✓
RTOL16CGNS1	Long Cord Grip (straight)	9.0-14.5	16	✓
RTOL16CGNS2	Long Cord Grip (straight)	13.5-17	16	✓
RTOB16CGNS1	Cord Grip (90°)	9.5-14.5	17	✓
RTOB16CGNS2	Cord Grip (90°)	13.5-17.0	17	✓

*Connector parts with part numbers ending in EC (with an end cap) were not available for submittal at the time of UL certification.

Shell Size: 16 Number of Contacts: 19
 Sealing: IP67 Salt Spray: 48h

Contact Size: 16

Dimensions Jam Nut Receptacle

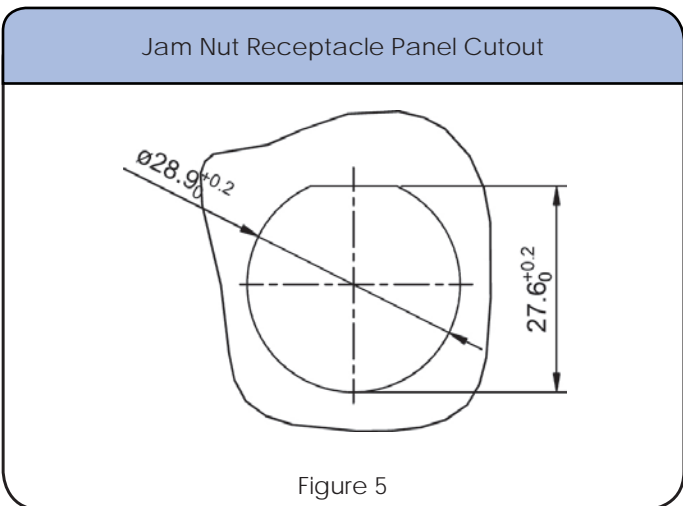
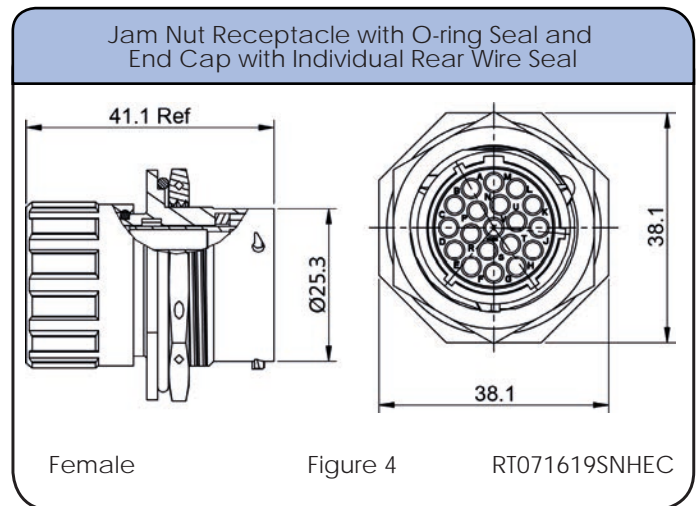
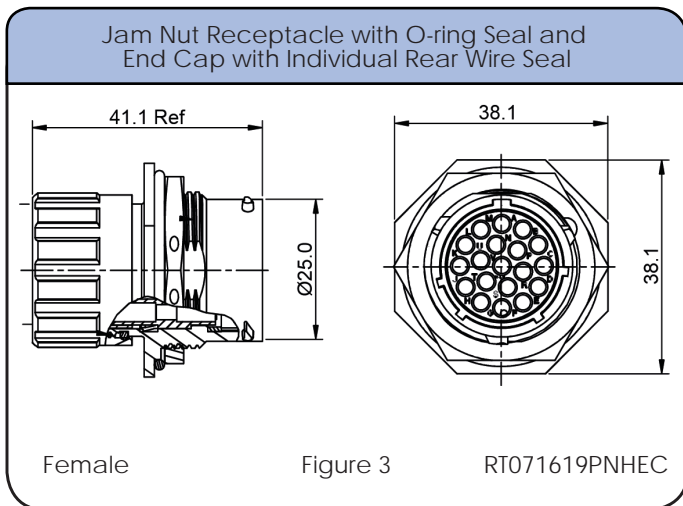
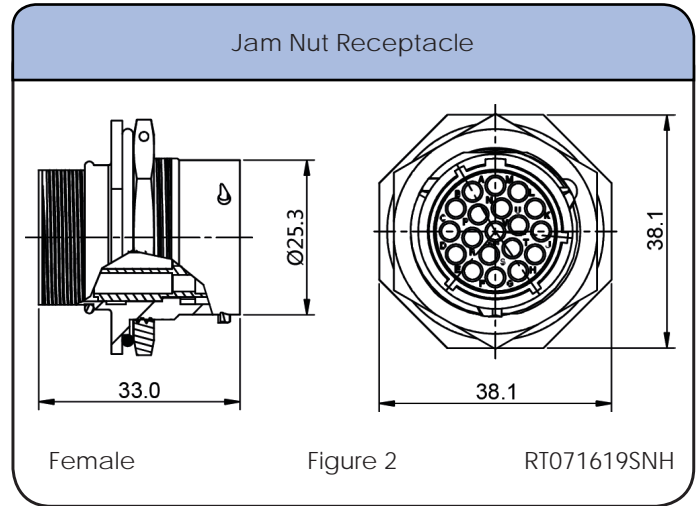
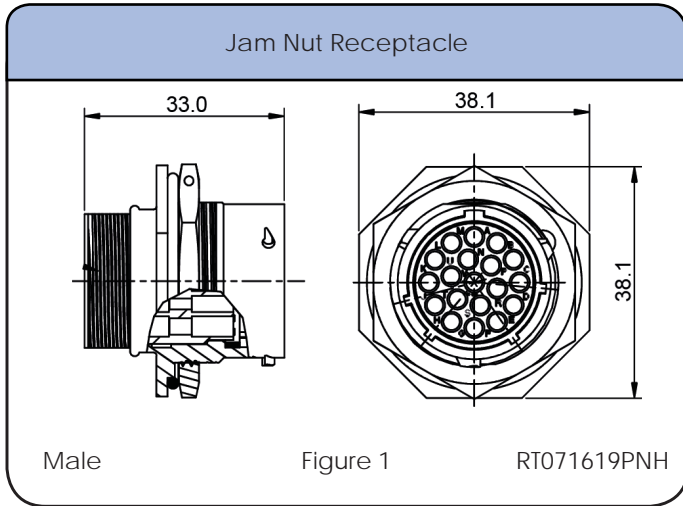

Shell Size: 16 Number of Contacts: 19 Contact Size: 16
Sealing: IP67 Salt Spray: 48h

Dimensions Plug

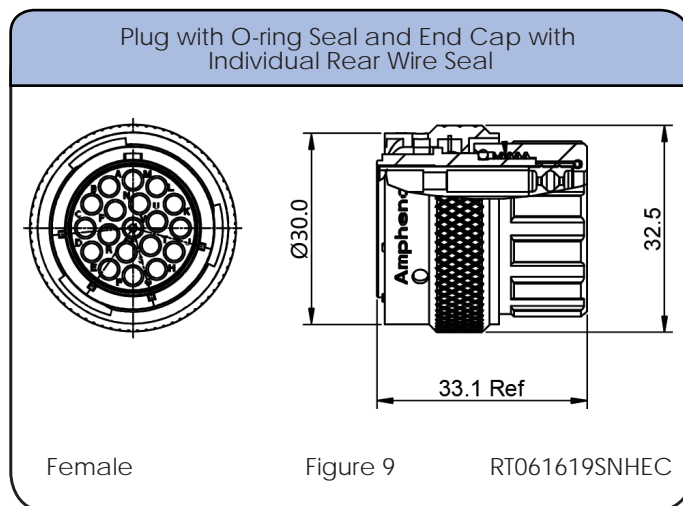
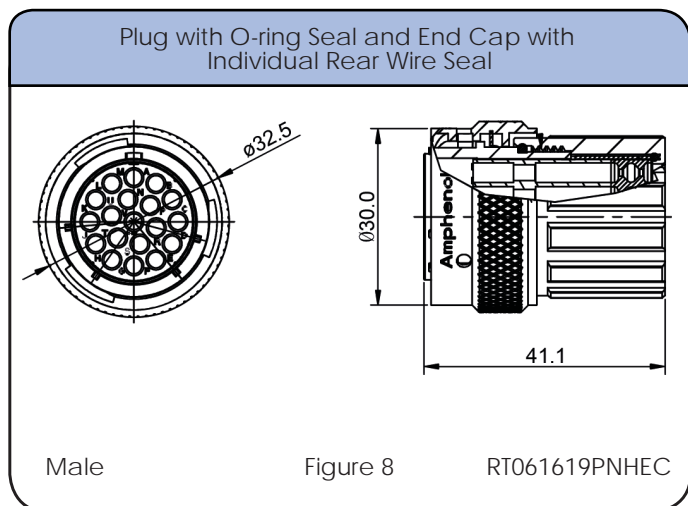
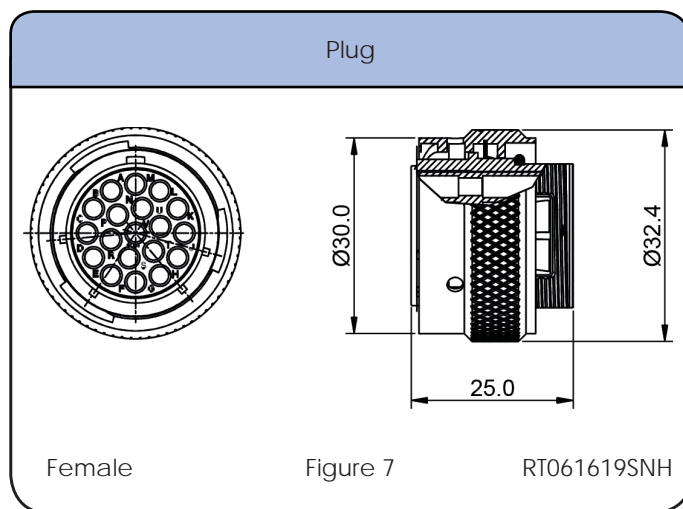
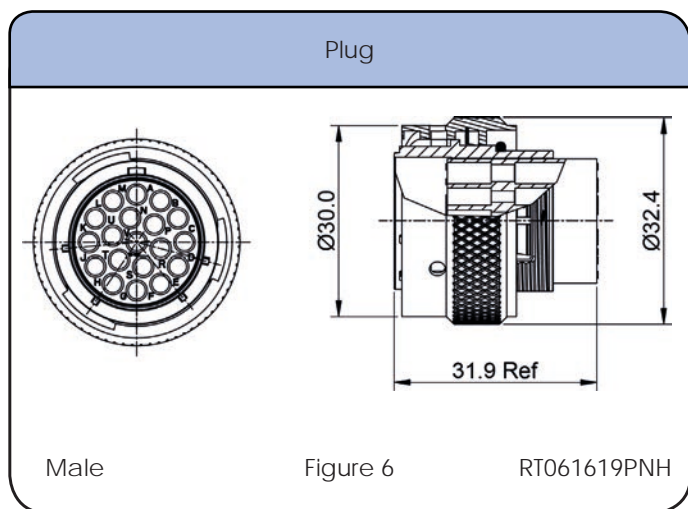

Individual Sealing Wire Range

Contact Size	Insulation Overall Diameter (min-max)	Wire Range
16	Ø2.0mm - Ø3.2mm	14 - 24 AWG

Shell Size: 16 Number of Contacts: 19 Contact Size: 16
 Sealing: IP67 Salt Spray: 48h

Dimensions Square Flange Receptacle

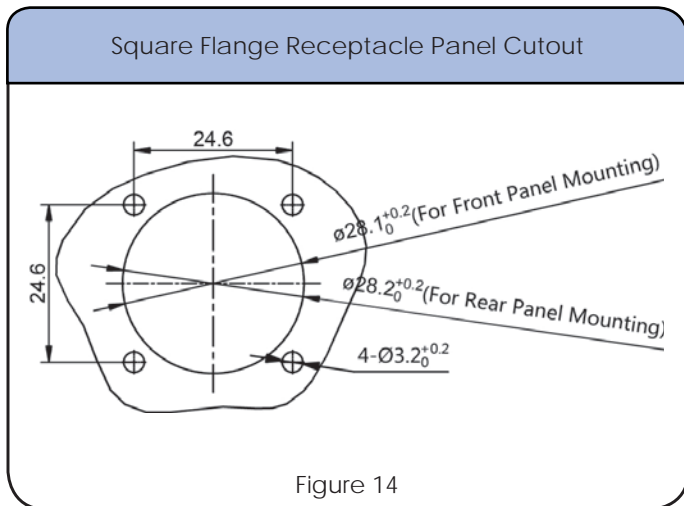
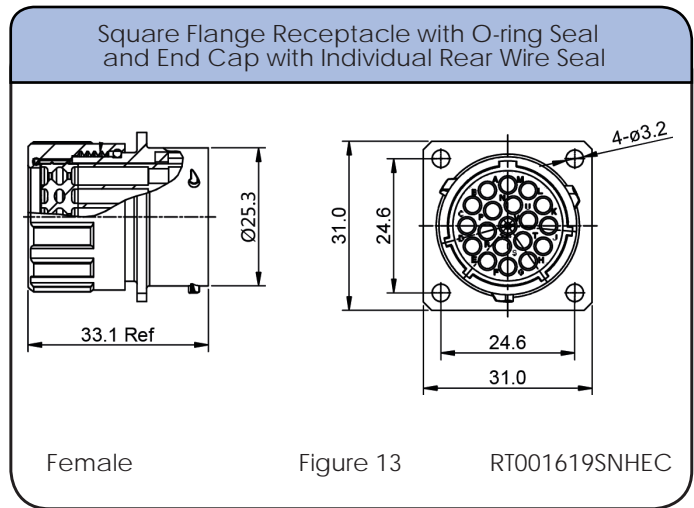
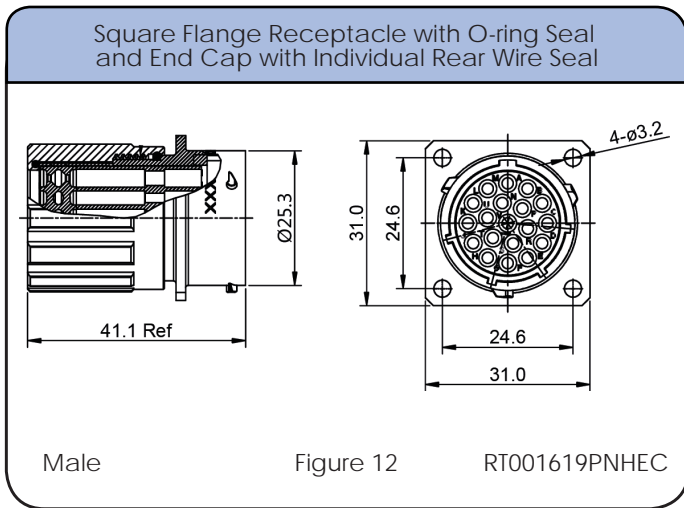
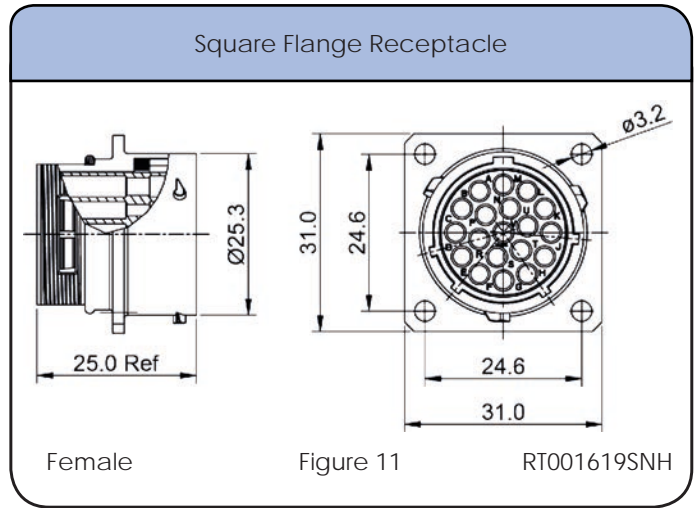
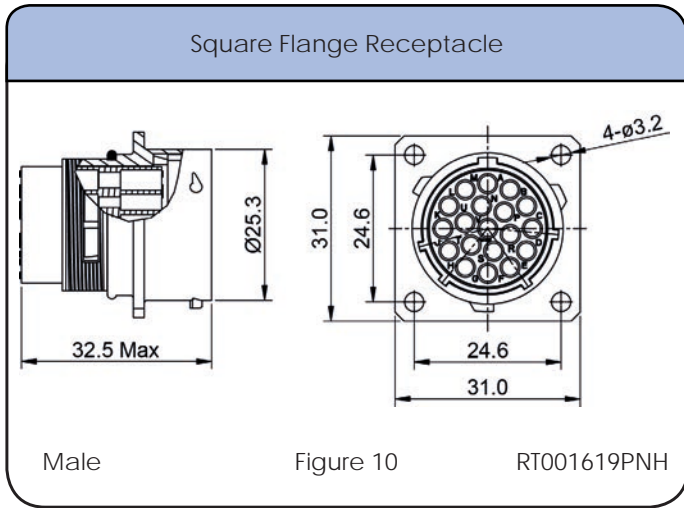

Shell Size: 16 Number of Contacts: 19 Contact Size: 16
Sealing: IP67 Salt Spray: 48h

Dimensions Backshell

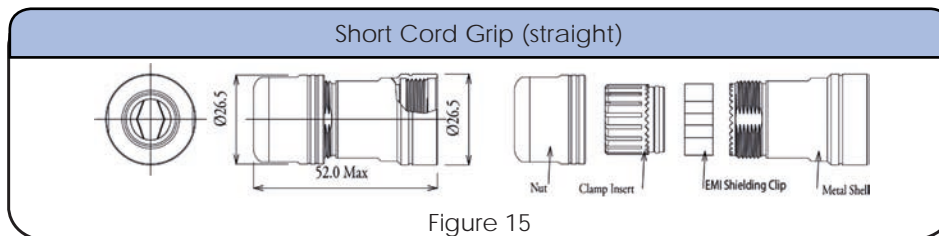

Figure 15

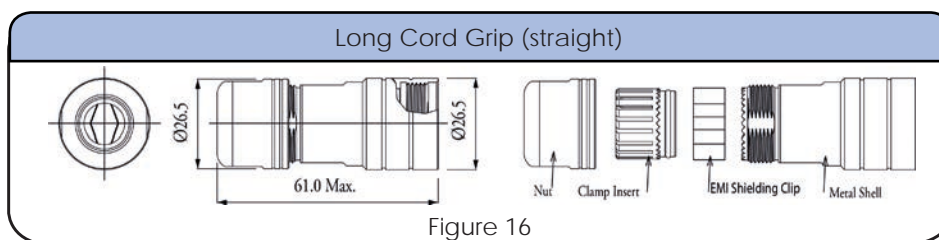

Figure 16

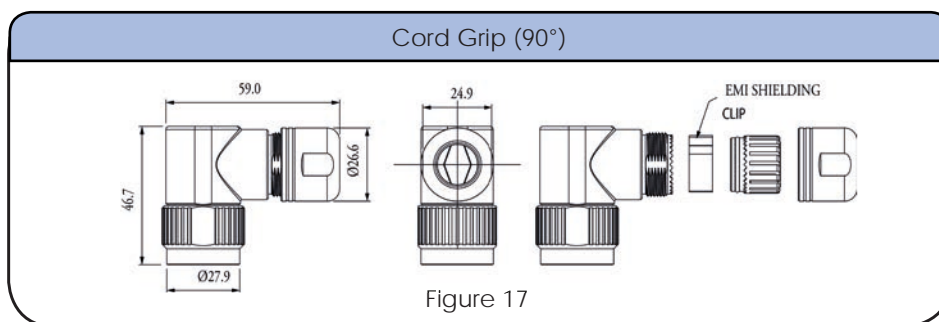











Figure 17

Accessories

<p>Locking Clip with Lanyard</p>  <p>108039116</p>	<p>Plug Dustcap with Chain</p>  <p>RT616DCG</p>	<p>Plug Dustcap without Chain</p>  <p>RT616DC</p>	<p>Receptacle Dustcap with Chain</p>  <p>RT016DCG</p>
<p>Receptacle Dustcap with Nylon Cord, Made of Rubber</p>  <p>RT016RL</p>	<p>Receptacle Dustcap without Chain</p>  <p>RT016DC</p>	<p>Receptacle Dustcap without Nylon Cord, Rubber Material</p>  <p>RB00011916</p>	<p>Sealing Plug</p>  <p>CA401659</p>
<p>Square Flange Receptacle Gaskets, Thickness 0.8mm (±0.2)</p>  <p>RTFD16B</p>			

NEW!
See
Page
16

Shell Size: 16
Sealing: IP67

Number of Contacts: 19
Salt Spray: 48h

Contact Size: 16

Contacts



Crimp Contacts, Machined

Part Number		AWG	Wire Range (mm ²)	Plating
Male	Female			
MP14M23F	MS14M23F	14	2.0-2.5	Gold Flash
MP14M23G5	MS14M23G5	14	2.0-2.5	Gold 5μ"
MP14M23G10	MS14M23G10	14	2.0-2.5	Gold 10μ"
MP14M23G15	MS14M23G15	14	2.0-2.5	Gold 15μ"
MP14M23G30	MS14M23G30	14	2.0-2.5	Gold 30μ"
MP16M23F	MS16M23F	18-16	.75-1.5	Gold Flash
MP16M23G5	MS16M23G5	18-16	.75-1.5	Gold 5μ"
MP16M23G10	MS16M23G10	18-16	.75-1.5	Gold 10μ"
MP16M23G15	MS16M23G15	18-16	.75-1.5	Gold 15μ"
MP16M23G30	MS16M23G30	18-16	.75-1.5	Gold 30μ"
MP20M23F	MS20M23F	22-20	.34-.50	Gold Flash
MP20M23G5	MS20M23G5	22-20	.34-.50	Gold 5μ"
MP20M23G10	MS20M23G10	22-20	.34-.50	Gold 10μ"
MP20M23G15	MS20M23G15	22-20	.34-.50	Gold 15μ"
MP20M23G30	MS20M23G30	22-20	.34-.50	Gold 30μ"
MP24M23F	MS24M23F	26-24	.14-.25	Gold Flash
MP24M23G5	MS24M23G5	26-24	.14-.25	Gold 5μ"
MP24M23G10	MS24M23G10	26-24	.14-.25	Gold 10μ"
MP24M23G15	MS24M23G15	26-24	.14-.25	Gold 15μ"
MP24M23G30	MS24M23G30	26-24	.14-.25	Gold 30μ"

Tools



Shell Size: 16 Number of Contacts: 19 Contact Size: 16
Sealing: IP67 Salt Spray: 48h

Contacts (con't)



Stamped & Formed Contacts

Crimp Contacts, Stamped & Formed

Part Number		AWG	Wire Range (mm ²)	Plating
Male	Female			
SP14M1F	SS14M1F	14	2.0-2.5	Gold Flash
SP14M1G5	SS14M1G5	14	2.0-2.5	Gold 5μ"
SP14M1G10	SS14M1G10	14	2.0-2.5	Gold 10μ"
SP14M1G15	SS14M1G15	14	2.0-2.5	Gold 15μ"
SP14M1G30	SS14M1G30	14	2.0-2.5	Gold 30μ"
SP16M1F	SS16M1F	18-16	.75-1.5	Gold Flash
SP16M1G5	SS16M1G5	18-16	.75-1.5	Gold 5μ"
SP16M1G10	SS16M1G10	18-16	.75-1.5	Gold 10μ"
SP16M1G15	SS16M1G15	18-16	.75-1.5	Gold 15μ"
SP16M1G30	SS16M1G30	18-16	.75-1.5	Gold 30μ"
SP20M1F	SS20M1F	22-20	.34-.50	Gold Flash
SP20M1G5	SS20M1G5	22-20	.34-.50	Gold 5μ"
SP20M1G10	SS20M1G10	22-20	.34-.50	Gold 10μ"
SP20M1G15	SS20M1G15	22-20	.34-.50	Gold 15μ"
SP20M1G30	SS20M1G30	22-20	.34-.50	Gold 30μ"
SP24M1F	SS24M1F	22-20	.14-.25	Gold Flash
SP24M1G5	SS24M1G5	26-24	.14-.25	Gold 5μ"
SP24M1G10	SS24M1G10	26-24	.14-.25	Gold 10μ"
SP24M1G15	SS24M1G15	26-24	.14-.25	Gold 15μ"
SP24M1G30	SS24M1G30	26-24	.14-.25	Gold 30μ"

Tools

Contact Extraction Tool,
#16 (Ø 1.6) Contact



QXRT16

Hand Tool, Stamped & Formed
Contact, Size 16, 20-14AWG



MFX-3954

Crimp Die for Stamped &
Formed Contact



MFX-3957

STEP 1
Choose Receptacle Style

STEP 2
Choose Plug Style

STEP 2
Choose Backshell Style

Jam Nut Receptacles



OR
Square Flange Receptacles



Jam Nut Receptacle Kit Including Receptacle & Contacts



Square Flange Receptacle Kit Including Receptacle, Gasket & Contacts



Plug



Backshell



OR
Plug Kit Including Connector, Backshell & Contacts



SEE TABLE ON NEXT PAGE FOR PART DETAILS

CONTACTS SOLD SEPARATELY SEE PAGE 148

Shell Size: 18 Number of Contacts: 23 Contact Size: 16
Sealing: IP67 Salt Spray: 48h

eco | mate[®] rm
Standard Products

- Suitable For Indoor and Outdoor Applications
- EMI/RMI Shielding Capability with Appropriate Backshell
- Operating Temperature: -40°C to +105°C
- 500 Mating Cycles
- Contacts and Cord Grips Ordered Separately
- UL ECBT2 Certified*

An upgraded silicone seal is available for all connector parts. Please add "03" to the end of the part number when ordering. Operating Temperature: -40°C to +125°C. Not available in kits.

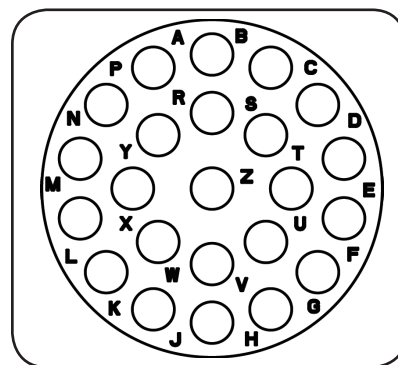

Insert Arrangement
Pin (Male) Faceview

Connector Part Numbers

Part Number		Connector Type	Figure Drawings	
Male	Female		Male	Female
RT071823PNH	RT071823SNH	Jam Nut Receptacle	1,5	2,5
RT071823PNHEC	RT071823SNHEC	Jam Nut Receptacle with O-ring Seal and End Cap with Individual Rear Wire Seal**	3,5	4,5
RT071823PNHK	RT071823SNHK	Jam Nut Receptacle Kit	1,5	2,5
RT061823PNH	RT061823SNH	Plug	6	7
RT061823PNHEC	RT061823SNHEC	Plug with O-ring Seal and End Cap with Individual Rear Wire Seal**	8	9
RT061823PNHK	RT061823SNHK	Plug Kit	1,5	2,5
RT001823PNH	RT001823SNH	Square Flange Receptacle	10,14	11,14
RT001823PNHEC	RT001823SNHEC	Square Flange Receptacle with O-ring Seal and End Cap with Individual Rear Wire Seal**	12,14	13,14
RT001823PNHK	RT001823SNHK	Square Flange Receptacle Kit	10,14	11,14

Contacts supplied separately see page 148

**See page 145 for the real seal wire range

Backshells

Part Number	Backshell Type	Cable Range (mm)	Figure Drawings	Shielding
RT0S18CGNS1	Short Cord Grip (straight)	9.0-14.5	15	✓
RT0S18CGNS2	Short Cord Grip (straight)	13.5-17	15	✓
RT0L18CGNS1	Long Cord Grip (straight)	9.0-14.5	16	✓
RT0L18CGNS2	Long Cord Grip (straight)	13.5-17	16	✓

*Connector parts with part numbers ending in EC (with an end cap) were not available for submittal at the time of UL certification.

Shell Size: 18 Number of Contacts: 23
 Sealing: IP67 Salt Spray: 48h

Contact Size: 16

Dimensions Jam Nut Receptacle

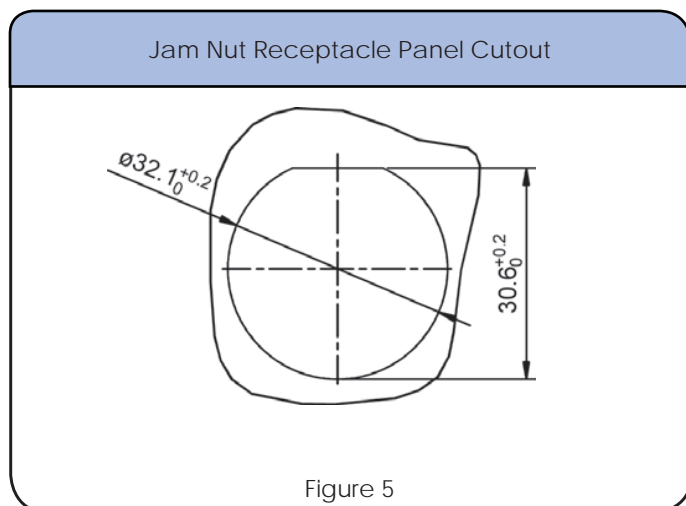
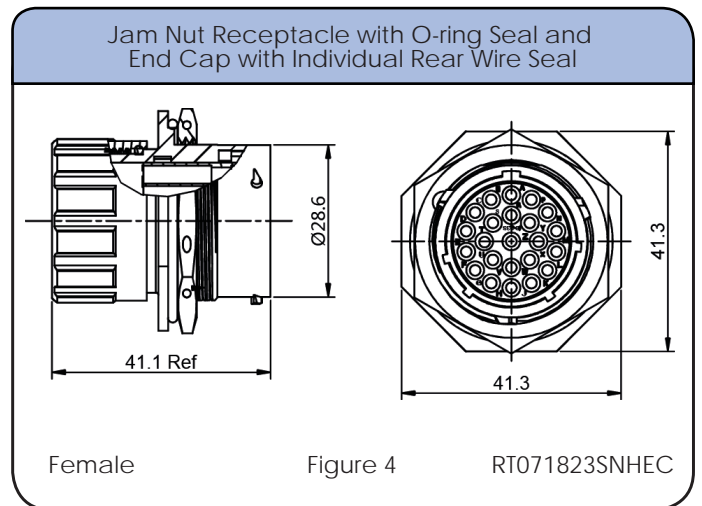
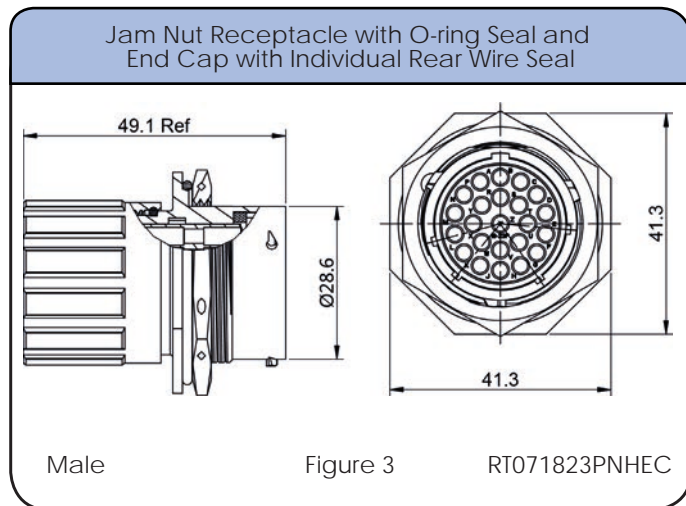
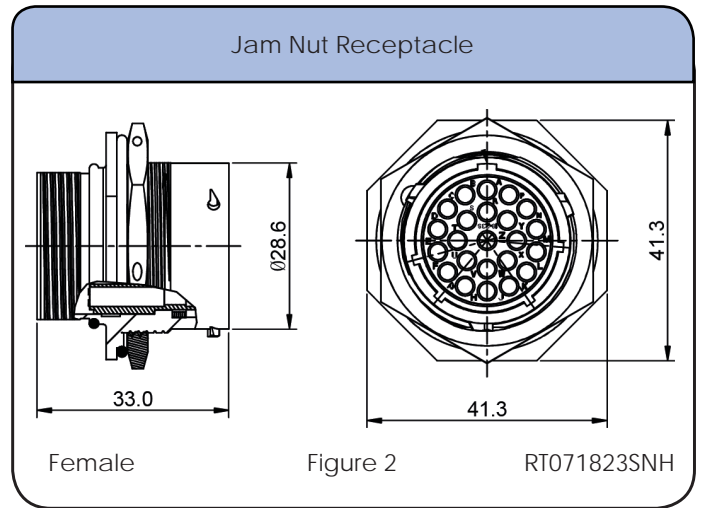
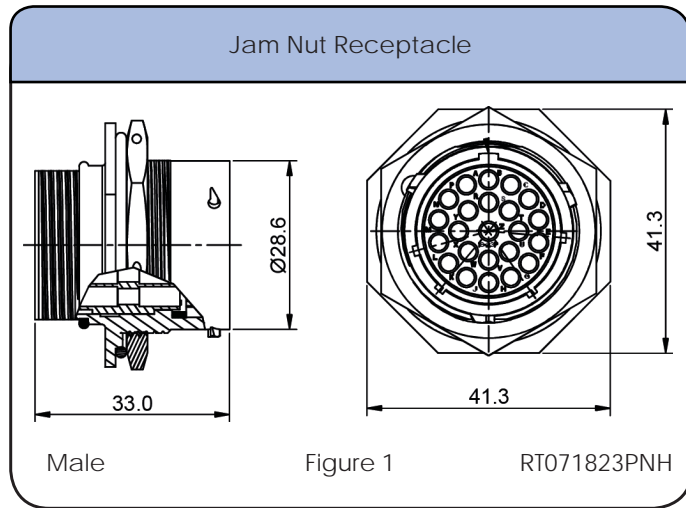

Shell Size: 18 Number of Contacts: 23
Sealing: IP67 Salt Spray: 48h

Contact Size: 16

Dimensions Plug

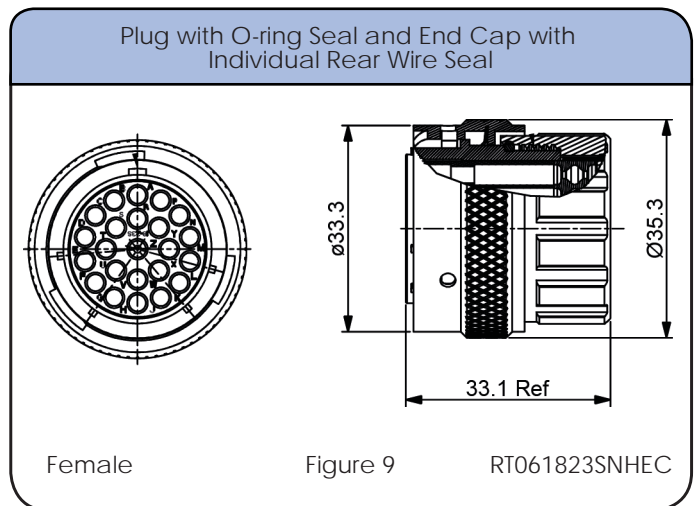
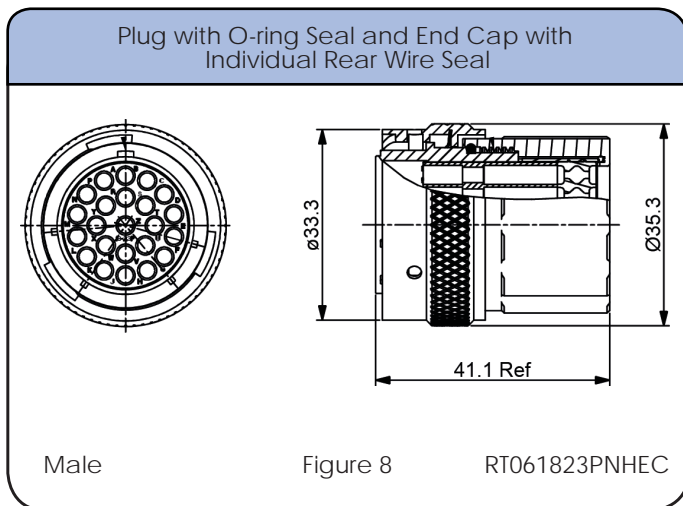
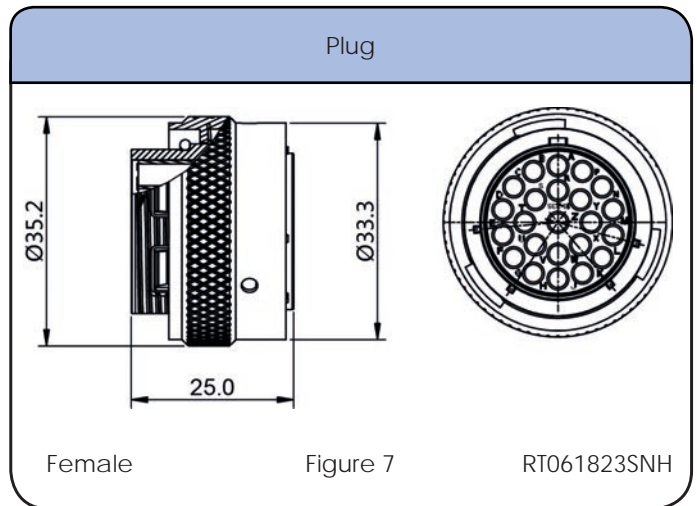
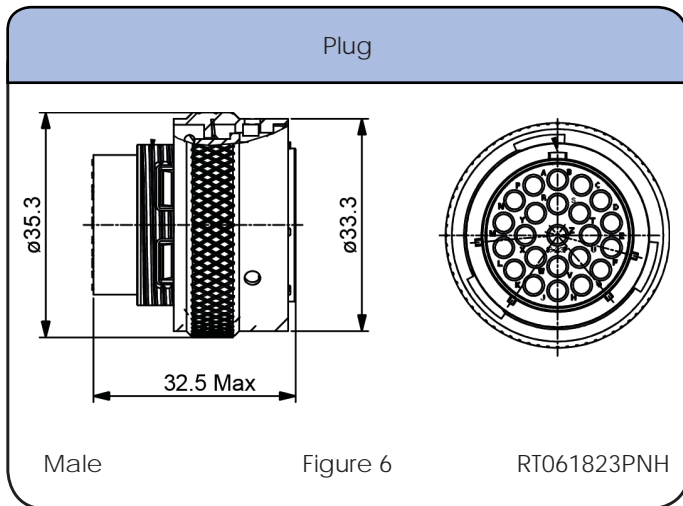

Individual Sealing Wire Range

Contact Size	Insulation Overall Diameter (min-max)	Wire Range
16	Ø2.0mm - Ø3.2mm	14 - 24 AWG

Shell Size: 18 Number of Contacts: 23 Contact Size: 16
 Sealing: IP67 Salt Spray: 48h

Dimensions Square Flange Receptacle

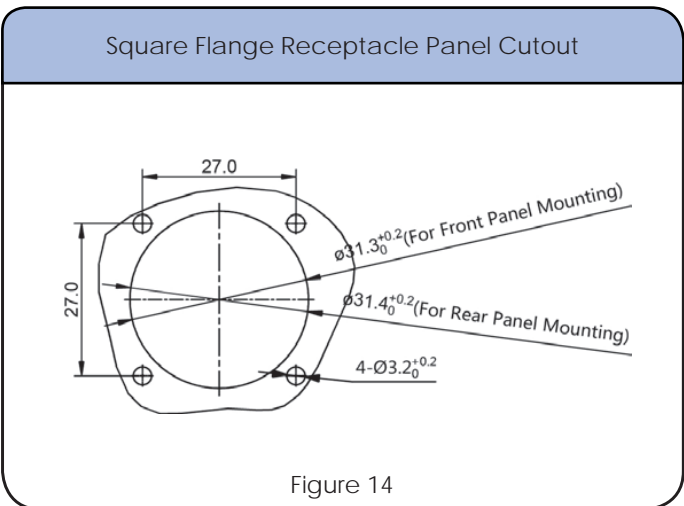
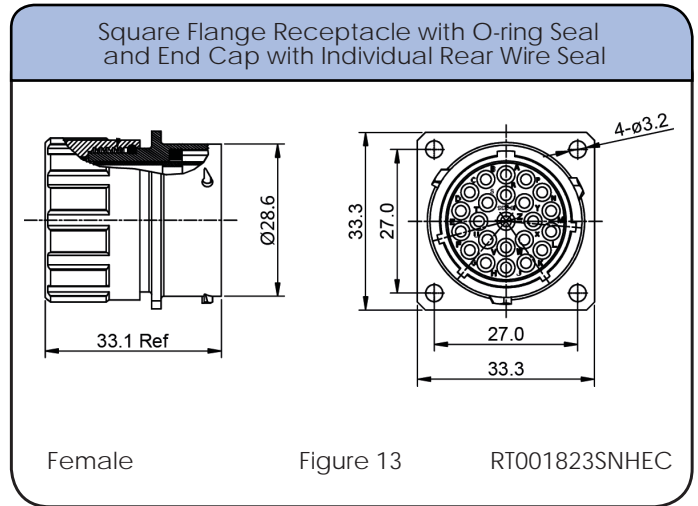
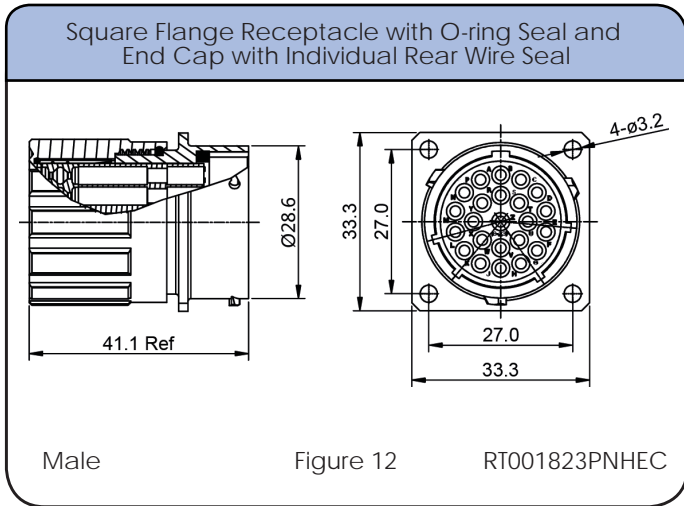
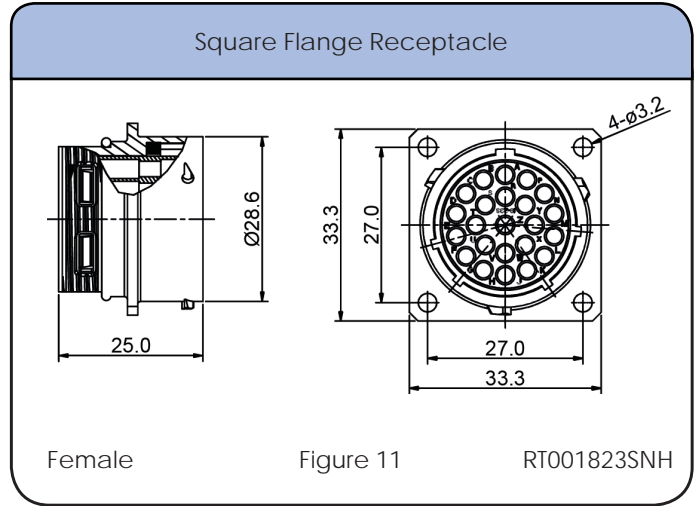
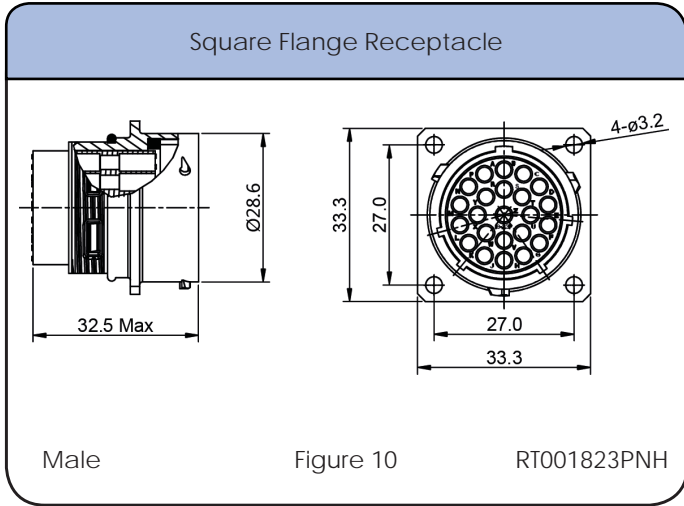

Shell Size: 18 Number of Contacts: 23 Contact Size: 16
Sealing: IP67 Salt Spray: 48h

Dimensions Backshell

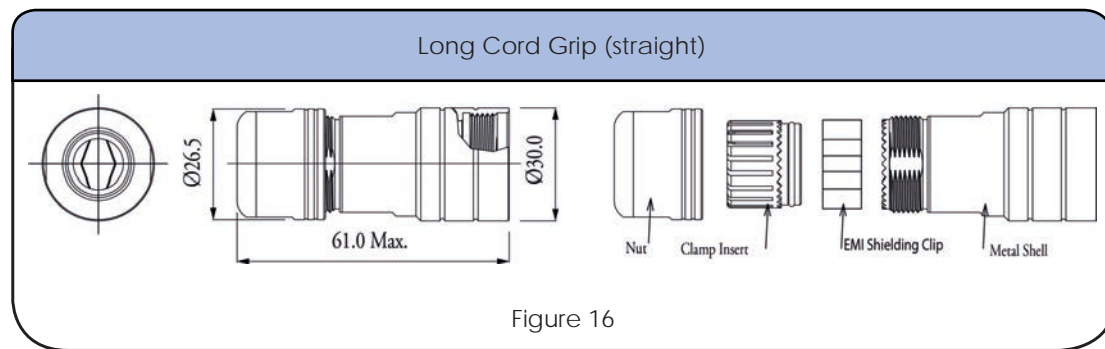
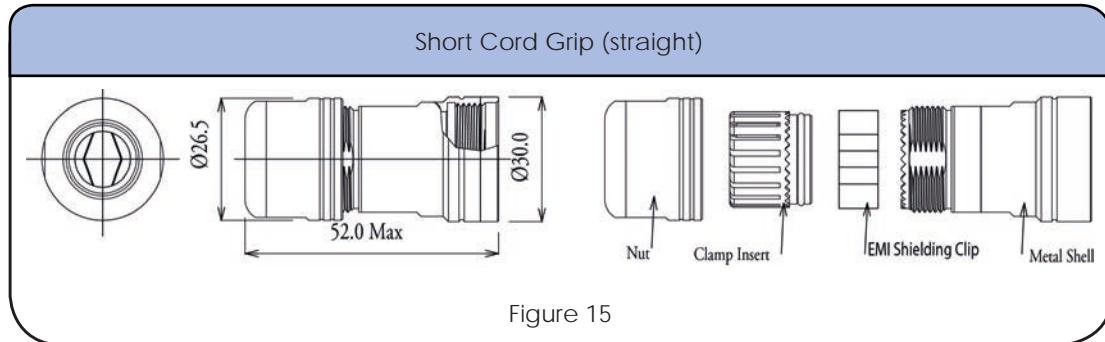

Accessories

<p>Locking Clip with Lanyard</p> <p>108039118</p>	<p>Plug Dustcap with Chain</p> <p>RT618DCG</p>	<p>Plug Dustcap without Chain</p> <p>RT618DC</p>	<p>Receptacle Dustcap with Chain</p> <p>RT018DCG</p>
<p>Receptacle Dustcap with Nylon Cord, Made of Rubber</p> <p>RT018RL</p>	<p>Receptacle Dustcap without Chain</p> <p>RT018DC</p>	<p>Receptacle Dustcap without Nylon Cord, Rubber Material</p> <p>RB00011918</p>	<p>Sealing Plug</p> <p>CA401659</p>
<p>Square Flange Receptacle Gaskets, Thickness 0.8mm (±0.2)</p> <p>RTFD18B</p>			

Shell Size: 18
Sealing: IP67

Number of Contacts: 23
Salt Spray: 48h

Contact Size: 16

Contacts



Crimp Contacts, Machined

Part Number		AWG	Wire Range (mm ²)	Plating
Male	Female			
MP14M23F	MS14M23F	14	2.0-2.5	Gold Flash
MP14M23FG5	MS14M23G5	14	2.0-2.5	Gold 5μ"
MP14M23FG10	MS14M23G10	14	2.0-2.5	Gold 10μ"
MP14M23FG15	MS14M23G15	14	2.0-2.5	Gold 15μ"
MP14M23G30	MS14M23G30	14	2.0-2.5	Gold 30μ"
MP16M23F	MS16M23F	18-16	.75-1.5	Gold Flash
MP16M23G5	MS16M23G5	18-16	.75-1.5	Gold 5μ"
MP16M23G10	MS16M23G10	18-16	.75-1.5	Gold 10μ"
MP16M23G15	MS16M23G15	18-16	.75-1.5	Gold 15μ"
MP16M23G30	MS16M23G30	18-16	.75-1.5	Gold 30μ"
MP20M23F	MS20M23F	22-20	.34-.50	Gold Flash
MP20M23G5	MS20M23G5	22-20	.34-.50	Gold 5μ"
MP20M23G10	MS20M23G10	22-20	.34-.50	Gold 10μ"
MP20M23G15	MS20M23G15	22-20	.34-.50	Gold 15μ"
MP20M23G30	MS20M23G30	22-20	.34-.50	Gold 30μ"
MP24M23F	MS24M23F	26-24	.14-.25	Gold Flash
MP24M23G5	MS24M23G5	26-24	.14-.25	Gold 5μ"
MP24M23G10	MS24M23G10	26-24	.14-.25	Gold 10μ"
MP24M23G15	MS24M23G15	26-24	.14-.25	Gold 15μ"
MP24M23G30	MS24M23G30	26-24	.14-.25	Gold 30μ"

Tools



Shell Size: 18 Number of Contacts: 23 Contact Size: 16
Sealing: IP67 Salt Spray: 48h

Contacts (con't)



Stamped & Formed Contacts

Crimp Contacts, Stamped & Formed

Part Number		AWG	Wire Range (mm ²)	Plating
Male	Female			
SP14M1F	SS14M1F	14	2.0-2.5	Gold Flash
SP14M1G5	SS14M1G5	14	2.0-2.5	Gold 5μ"
SP14M1G10	SS14M1G10	14	2.0-2.5	Gold 10μ"
SP14M1G15	SS14M1G15	14	2.0-2.5	Gold 15μ"
SP14M1G30	SS14M1G30	14	2.0-2.5	Gold 30μ"
SP16M1F	SS16M1F	18-16	.75-1.5	Gold Flash
SP16M1G5	SS16M1G5	18-16	.75-1.5	Gold 5μ"
SP16M1G10	SS16M1G10	18-16	.75-1.5	Gold 10μ"
SP16M1G15	SS16M1G15	18-16	.75-1.5	Gold 15μ"
SP16M1G30	SS16M1G30	18-16	.75-1.5	Gold 30μ"
SP20M1F	SS20M1F	22-20	.34-.50	Gold Flash
SP20M1G5	SS20M1G5	22-20	.34-.50	Gold 5μ"
SP20M1G10	SS20M1G10	22-20	.34-.50	Gold 10μ"
SP20M1G15	SS20M1G15	22-20	.34-.50	Gold 15μ"
SP20M1G30	SS20M1G30	22-20	.34-.50	Gold 30μ"
SP24M1F	SS24M1F	22-20	.14-.25	Gold Flash
SP24M1G5	SS24M1G5	26-24	.14-.25	Gold 5μ"
SP24M1G10	SS24M1G10	26-24	.14-.25	Gold 10μ"
SP24M1G15	SS24M1G15	26-24	.14-.25	Gold 15μ"
SP24M1G30	SS24M1G30	26-24	.14-.25	Gold 30μ"

Tools



Contact Extraction Tool, #16 (Ø 1.6) Contact

QXRT16



Hand Tool, Stamped & Formed Contact, Size 16, 20-14AWG

MFX-3954



Crimp Die for Stamped & Formed Contact

MFX-3957

STEP 1
Choose Receptacle Style

STEP 2
Choose Plug Style

STEP 2
Choose Backshell Style

Jam Nut Receptacles



Jam Nut Receptacle Kit Including Receptacle & Contacts



OR
Square Flange Receptacles



Square Flange Receptacle Kit Including Receptacle, Gasket & Contacts



Plug



Backshell



OR
Plug Kit Including Connector, Backshell & Contacts



SEE TABLE ON NEXT PAGE FOR PART DETAILS

CONTACTS SOLD SEPARATELY SEE PAGE 156

Shell Size: 16 Number of Contacts: 26 Contact Size: 20
Sealing: IP67 Salt Spray: 48h

eco | mate[®] rm
Standard Products

- Suitable For Indoor and Outdoor Applications
- EMI/RMI Shielding Capability with Appropriate Backshell
- Operating Temperature: -40°C to +105°C
- 500 Mating Cycles
- Contacts and Cord Grips Ordered Separately
- UL ECBT2 Certified*

An upgraded silicone seal is available for all connector parts. Please add "03" to the end of the part number when ordering. Operating Temperature: -40°C to +125°C. Not available in kits.

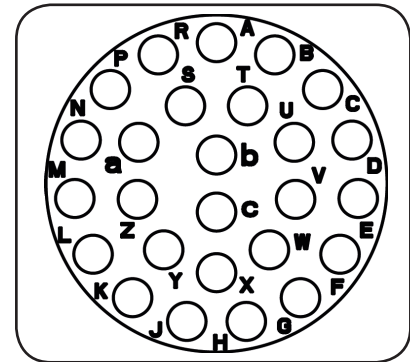

Insert Arrangement
Pin (Male) Faceview

Connector Part Numbers

Part Number		Connector Type	Figure Drawings	
Male	Female		Male	Female
RTOW71626PNH	RTOW71626SNH	Jam Nut Receptacle	1,5	2,5
RTOW71626PNHEC	RTOW71626SNHEC	Jam Nut Receptacle with O-ring Seal and End Cap with Individual Rear Wire Seal**	3,5	4,5
RTOW71626PNHK	RTOW71626SNHK	Jam Nut Receptacle Kit	1,5	2,5
RTOW61626PNH	RTOW61626SNH	Plug	6	7
RTOW61626PNHEC	RTOW61626SNHEC	Plug with O-ring Seal and End Cap with Individual Rear Wire Seal**	8	9
RTOW61626PNHK	RTOW61626SNHK	Plug Kit	6	7
RTOW01626PNH	RTOW01626SNH	Square Flange Receptacle	10,14	11,14
RTOW01626PNHEC	RTOW01626SNHEC	Square Flange Receptacle with Unshielded Backshell and End Cap with Individual Rear Wire Seal**	12,14	13,14
RTOW01626PNHK	RTOW01626SNHK	Square Flange Receptacle Kit	10,14	11,14

Contacts supplied separately see page 156

**See page 153 for the real seal wire range

Backshells

Part Number	Backshell Type	Cable Range (mm)	Figure Drawings	Shielding
RTOS16CGNS1	Short Cord Grip (straight)	9.0-14.5	15	✓
RTOS16CGNS2	Short Cord Grip (straight)	13.5-17	15	✓
RTOL16CGNS1	Long Cord Grip (straight)	9.0-14.5	16	✓
RTOL16CGNS2	Long Cord Grip (straight)	13.5-17	16	✓
RTOB16CGNS1	Cord Grip (90°)	9.5-14.5	17	✓
RTOB16CGNS2	Cord Grip (90°)	13.5-17.0	17	✓

*Connector parts with part numbers ending in EC (with an end cap) were not available for submittal at the time of UL certification.

Shell Size: 16 Number of Contacts: 26
 Sealing: IP67 Salt Spray: 48h

Contact Size: 20

Dimensions Jam Nut Receptacle

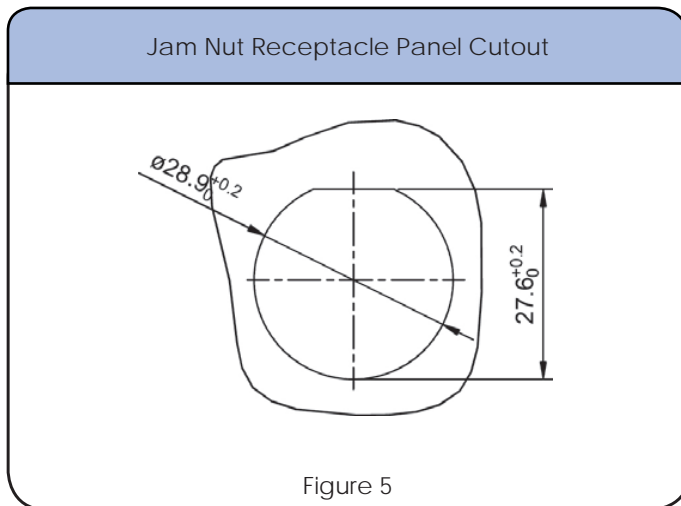
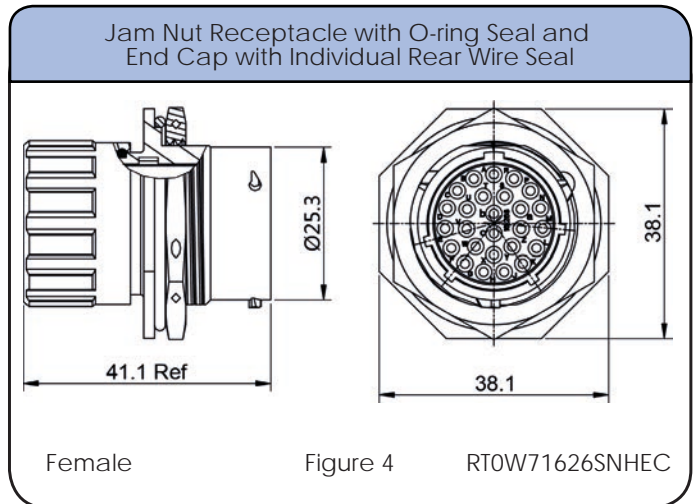
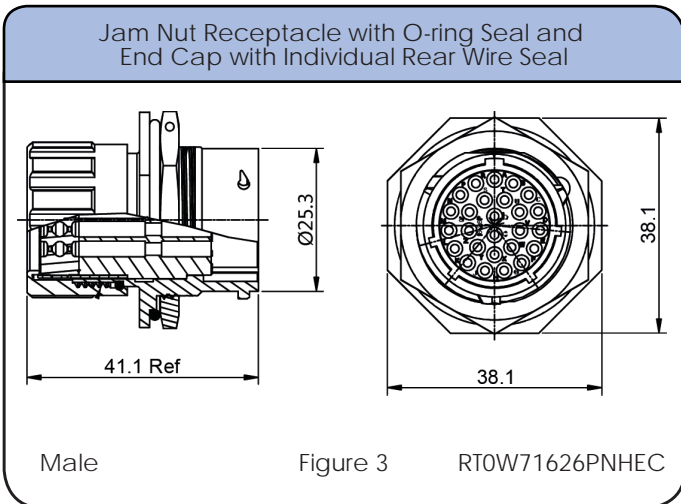
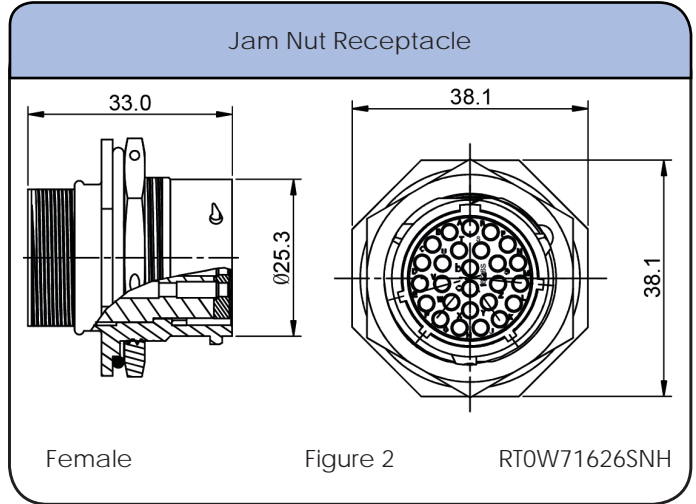
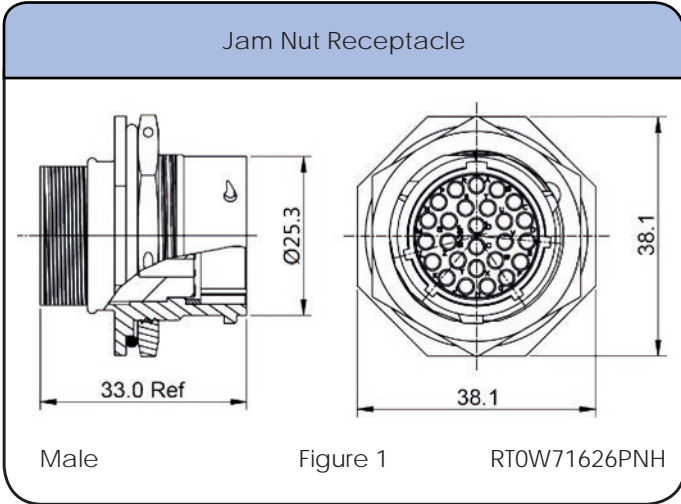

Shell Size: 16
Sealing: IP67

Number of Contacts: 26
Salt Spray: 48h

Contact Size: 20

Dimensions Plug

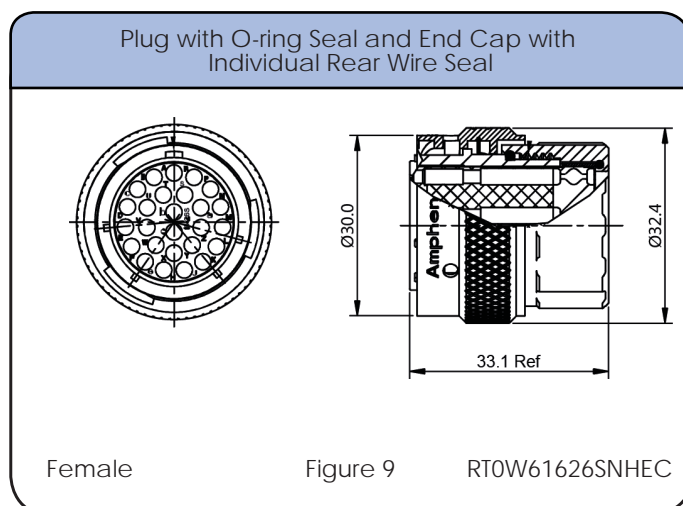
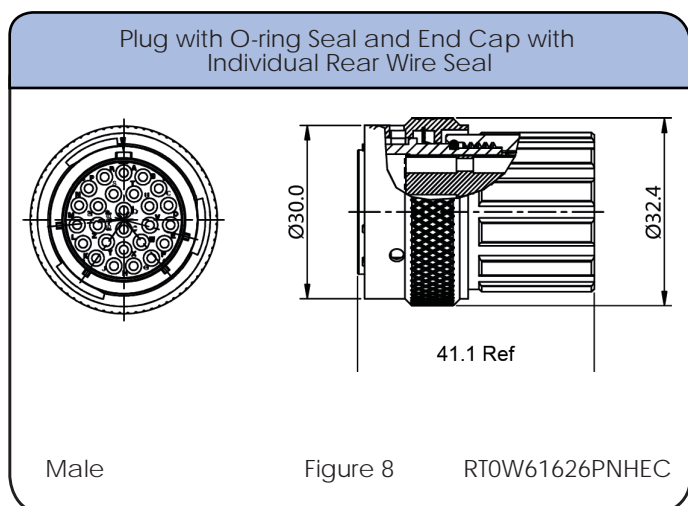
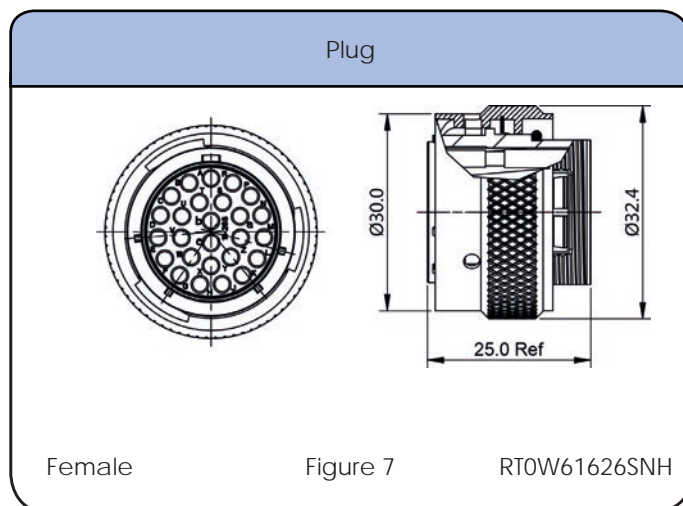
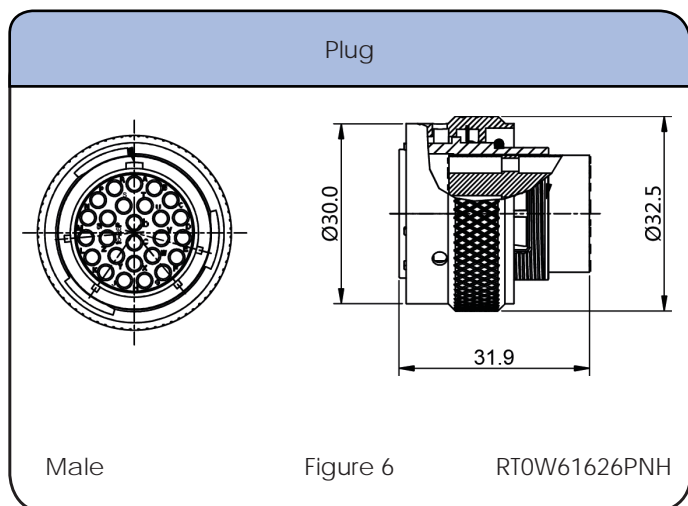

Individual Sealing Wire Range

Contact Size	Insulation Overall Diameter (min-max)	Wire Range
20	Ø1.6mm - Ø2.6mm	20 - 30 AWG

Shell Size: 16 Number of Contacts: 26 Contact Size: 20
 Sealing: IP67 Salt Spray: 48h

Dimensions Square Flange Receptacle

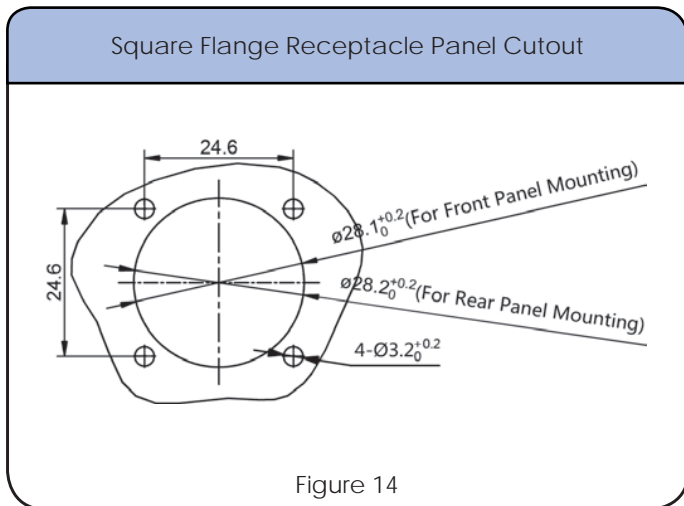
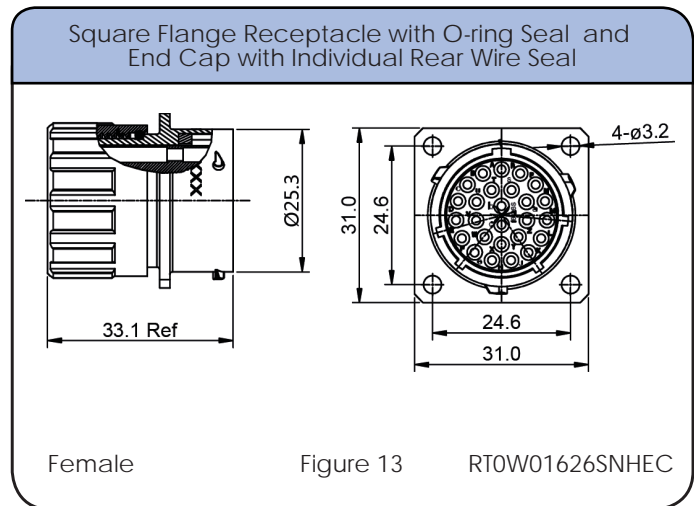
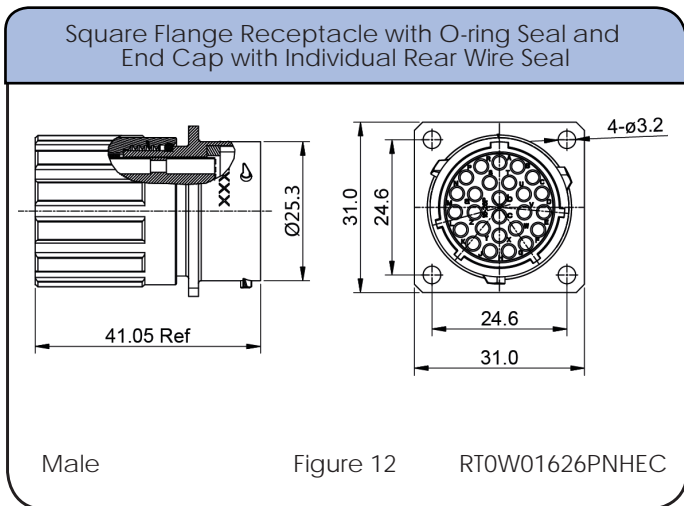
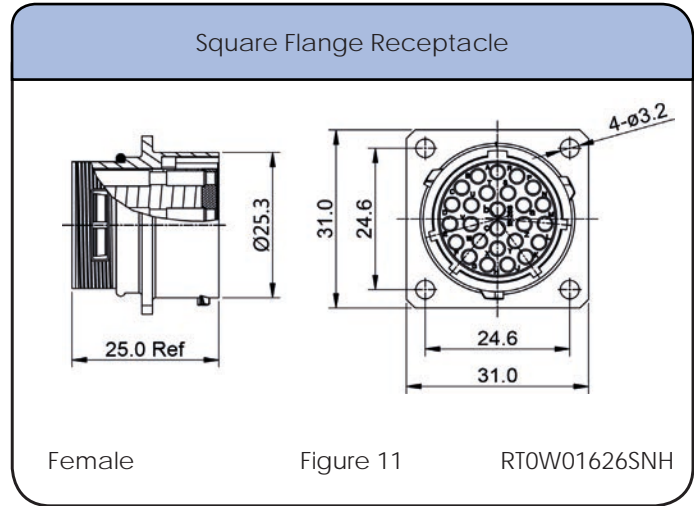
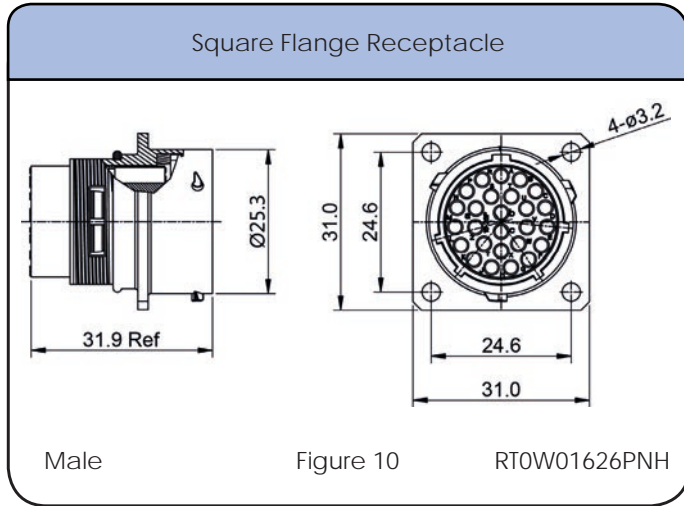

Shell Size: 16 Number of Contacts: 26 Contact Size: 20
Sealing: IP67 Salt Spray: 48h

Dimensions Backshell

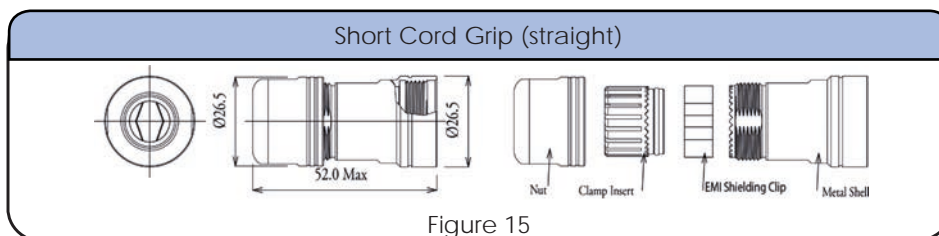

Figure 15

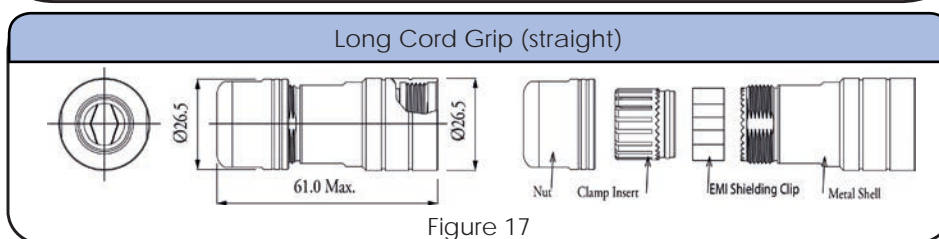

Figure 17

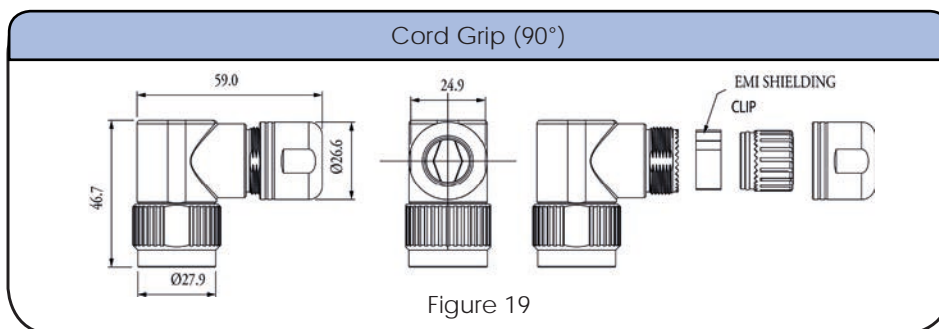











Figure 19

Accessories

<p>Locking Clip with Lanyard</p>  <p>NEW! See Page 16</p> <p>108039116</p>	<p>Plug Dustcap with Chain</p>  <p>RT616DCG</p>	<p>Plug Dustcap without Chain</p>  <p>RT616DC</p>	<p>Receptacle Dustcap with Chain</p>  <p>RT016DCG</p>
<p>Receptacle Dustcap with Nylon Cord, Made of Rubber</p>  <p>RT016RL</p>	<p>Receptacle Dustcap without Chain</p>  <p>RT016DC</p>	<p>Receptacle Dustcap without Nylon Cord, Rubber Material</p>  <p>RB00011916</p>	<p>Sealing Plug</p>  <p>CA402059</p>
<p>Square Flange Receptacle Gaskets, Thickness 0.8mm (±0.2)</p>  <p>RTFD16B</p>			

Shell Size: 16
Sealing: IP67

Number of Contacts: 26
Salt Spray: 48h

Contact Size: 20

Contacts



Crimp Contacts, Machined (7.5A Max)

Part Number		AWG	Wire Range (mm ²)	Plating
Male	Female			
MP20W23F	MS20W23F	22-20	.34-.50	Gold Flash
MP20W23G5	MS20W23G5	22-20	.34-.50	Gold 5μ"
MP20W23G10	MS20W23G10	22-20	.34-.50	Gold 10μ"
MP20W23G15	MS20W23G15	22-20	.34-.50	Gold 15μ"
MP20W23G30	MS20W23G30	22-20	.34-.50	Gold 30μ"
MP24W23F	MS24W23F	26-24	.13-.25	Gold Flash
MP24W23G5	MS24W23G5	26-24	.13-.25	Gold 5μ"
MP24W23G10	MS24W23G10	26-24	.13-.25	Gold 10μ"
MP24W23G15	MS24W23G15	26-24	.13-.25	Gold 15μ"
MP24W23G30	MS24W23G30	26-24	.13-.25	Gold 30μ"
MP28W23F	MS28W23F	30-28	.05-.08	Gold Flash
MP28W23G5	MS28W23G5	30-28	.05-.08	Gold 5μ"
MP28W23G10	MS28W23G10	30-28	.05-.08	Gold 10μ"
MP28W23G15	MS28W23G15	30-28	.05-.08	Gold 15μ"
MP28W23G30	MS28W23G30	30-28	.05-.08	Gold 30μ"

Tools



Shell Size: 16 Number of Contacts: 26 Contact Size: 20
Sealing: IP67 Salt Spray: 48h

Contacts (con't)



Stamped & Formed Contacts

Crimp Contacts, Stamped & Formed (5A Max)

Part Number		AWG	Wire Range (mm ²)	Plating
Male	Female			
SP20W1F	SS20W1F	22-20	.34-.50	Gold Flash
SP20W1G5	SS20W1G5	22-20	.34-.50	Gold 5μ"
SP20W1G10	SS20W1G10	22-20	.34-.50	Gold 10μ"
SP20W1G15	SS20W1G15	22-20	.34-.50	Gold 15μ"
SP20W1G30	SS20W1G30	22-20	.34-.50	Gold 30μ"
SP24W1F	SS24W1F	26-24	.14-.25	Gold Flash
SP24W1G5	SS24W1G5	26-24	.14-.25	Gold 5μ"
SP24W1G10	SS24W1G10	26-24	.14-.25	Gold 10μ"
SP24W1G15	SS24W1G15	26-24	.14-.25	Gold 15μ"
SP24W1G30	SS24W1G30	26-24	.14-.25	Gold 30μ"
SP28W1F	SS28W1F	30-28	.05-.08	Gold Flash
SP28W1G5	SS28W1G5	30-28	.05-.08	Gold 5μ"
SP28W1G10	SS28W1G10	30-28	.05-.08	Gold 10μ"
SP28W1G15	SS28W1G15	30-28	.05-.08	Gold 15μ"
SP28W1G30	SS28W1G30	30-28	.05-.08	Gold 30μ"

Tools



STEP 1
Choose Receptacle Style

STEP 2
Choose Plug Style

STEP 2
Choose Backshell Style

Jam Nut Receptacles



OR
Square Flange Receptacles



Jam Nut Receptacle Kit Including Receptacle & Contacts



Square Flange Receptacle Kit Including Receptacle, Gasket & Contacts



Plug



Backshell



OR

Plug Kit Including Connector, Backshell & Contacts



SEE TABLE ON NEXT PAGE FOR PART DETAILS

CONTACTS SOLD SEPARATELY SEE PAGE 164

Shell Size: 20 Number of Contacts: 28 Contact Size: 16
Sealing: IP67 Salt Spray: 48h

eco | mate[®] rm
Standard Products

- Suitable For Indoor and Outdoor Applications
- EMI/RMI Shielding Capability with Appropriate Backshell
- Operating Temperature: -40°C to +105°C
- 500 Mating Cycles
- Contacts and Cord Grips Ordered Separately
- UL ECBT2 Certified*

An upgraded silicone seal is available for all connector parts. Please add "03" to the end of the part number when ordering. Operating Temperature: -40°C to +125°C. Not available in kits.

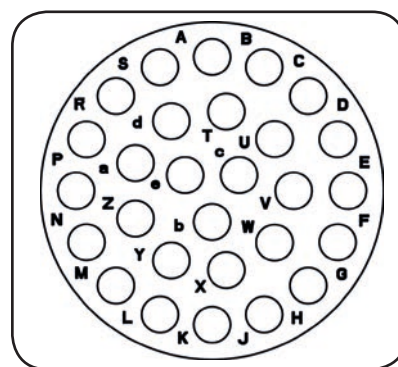

Insert Arrangement
Pin (Male) Faceview

Connector Part Numbers

Part Number		Connector Type	Figure Drawings	
Male	Female		Male	Female
RT072028PNH	RT072028SNH	Jam Nut Receptacle	1,5	2,5
RT072028PNHEC	RT072028SNHEC	Jam Nut Receptacle with O-ring Seal and End Cap with Individual Rear Wire Seal**	3,5	4,5
RT072028PNHK	RT072028SNHK	Jam Nut Receptacle Kit	1,5	2,5
RT062028PNH	RT062028SNH	Plug	6	7
RT062028PNHEC	RT062028SNHEC	Plug with O-ring Seal and End Cap with Individual Rear Wire Seal**	8	9
RT062028PNHK	RT062028SNHK	Plug Kit	6	7
RT002028PNH	RT002028SNH	Square Flange Receptacle	10,14	11,14
RT002028PNHEC	RT002028SNHEC	Square Flange Receptacle with O-ring Seal and End Cap with Individual Rear Wire Seal**	12,14	13,14
RT002028PNHK	RT002028SNHK	Square Flange Receptacle Kit	10,14	11,14

Contacts supplied separately see page 164
**See page 153 for the real seal wire range

Backshells

Part Number	Backshell Type	Cable Range (mm)	Figure Drawings	Shielding
RT0L20CPGS5	Long Cord Grip (straight)	12.5-13.3	15	✓
RT0L20CPGS6	Long Cord Grip (straight)	15.5-19.5	15	✓

*Connector parts with part numbers ending in EC (with an end cap) were not available for submittal at the time of UL certification.

Shell Size: 20 Number of Contacts: 28
 Sealing: IP67 Salt Spray: 48h

Contact Size: 16

Dimensions Jam Nut Receptacle

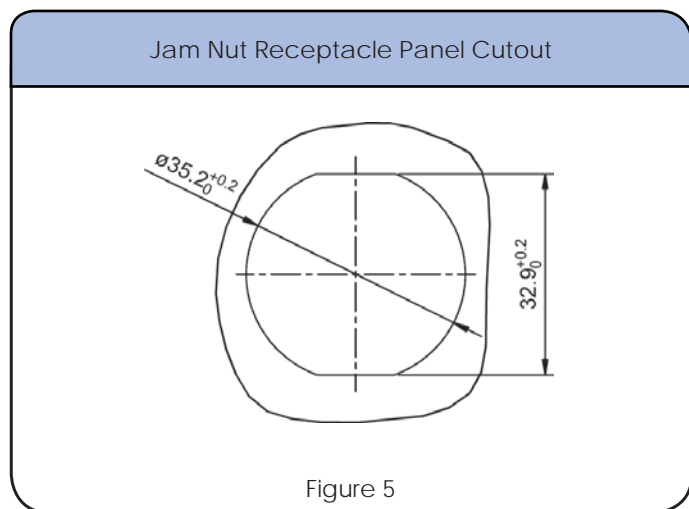
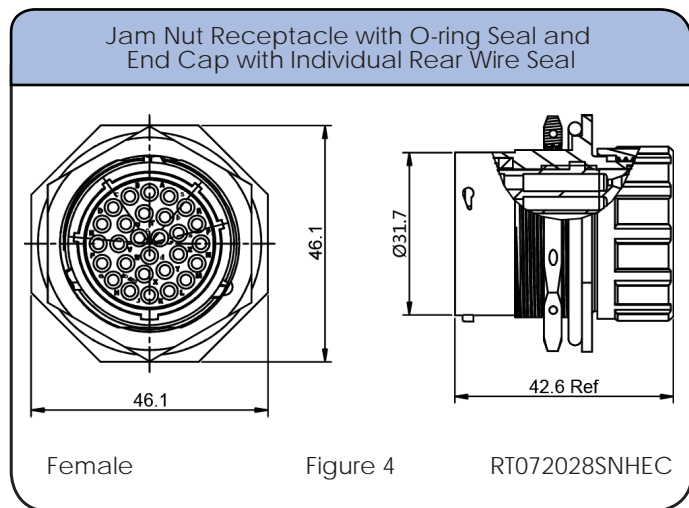
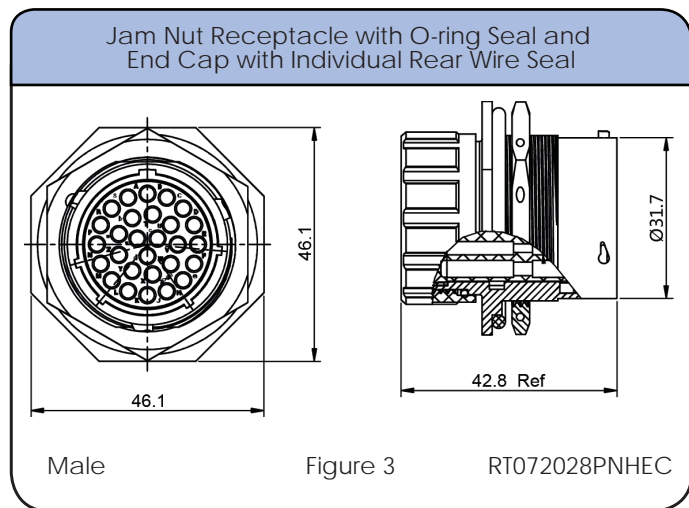
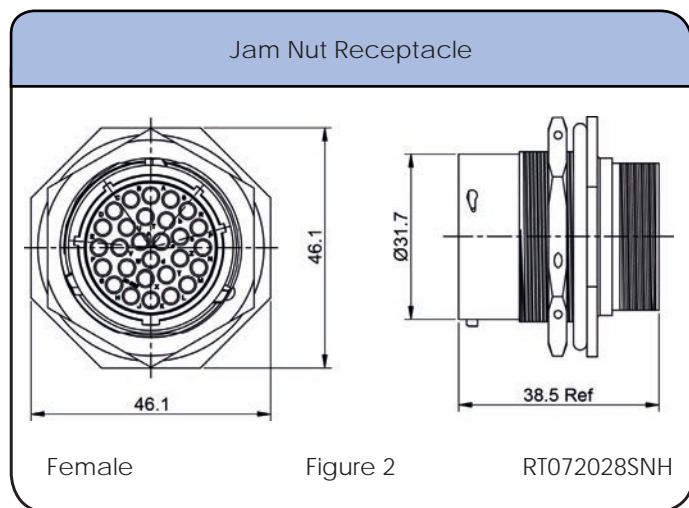
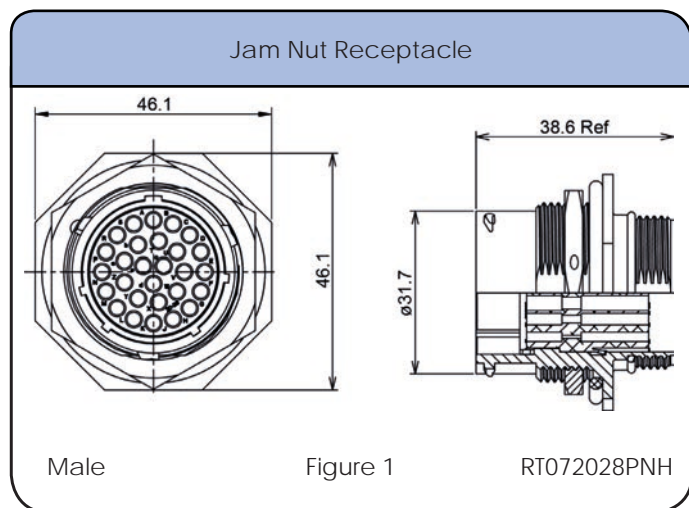

Shell Size: 20
Sealing: IP67

Number of Contacts: 28
Salt Spray: 48h

Contact Size: 16

Dimensions Plug

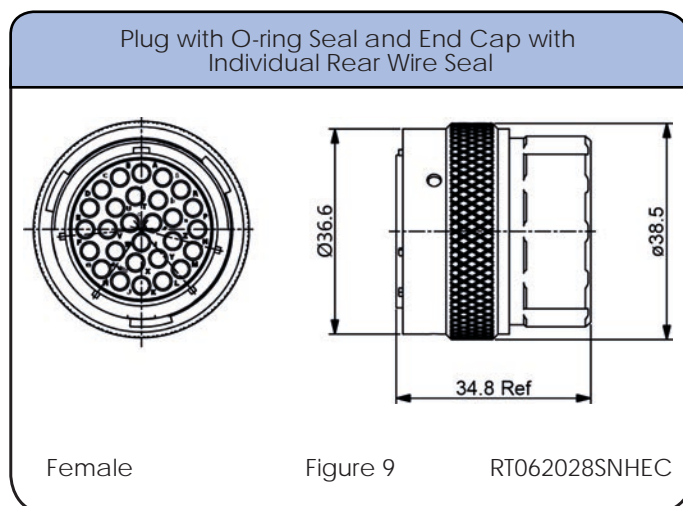
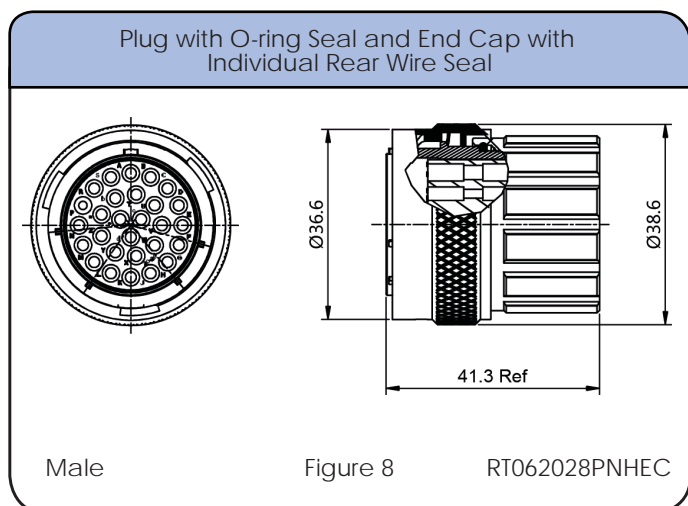
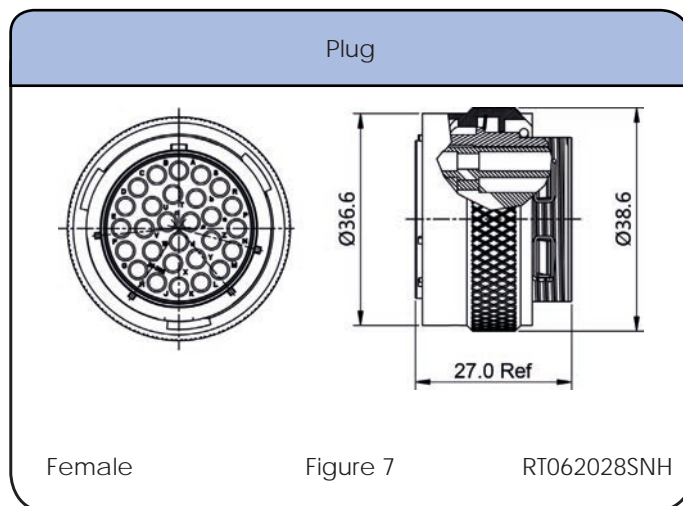
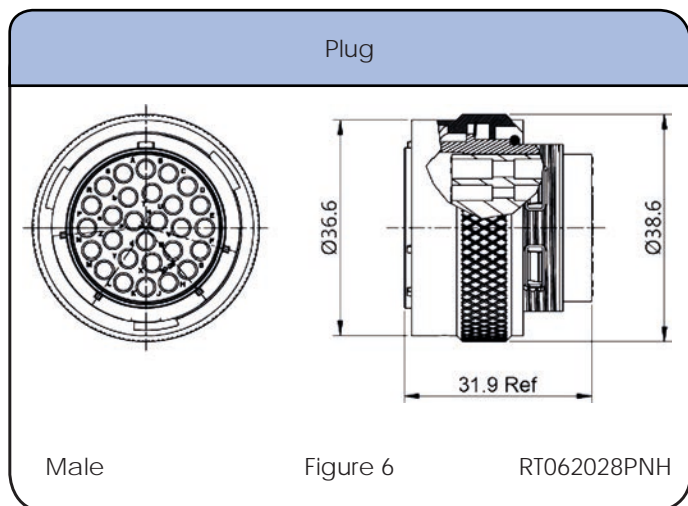

Individual Sealing Wire Range

Contact Size	Insulation Overall Diameter (min-max)	Wire Range
16	Ø2.0mm - Ø3.2mm	14 - 24 AWG

Shell Size: 20 Number of Contacts: 28 Contact Size: 16
 Sealing: IP67 Salt Spray: 48h

Dimensions Square Flange Receptacle

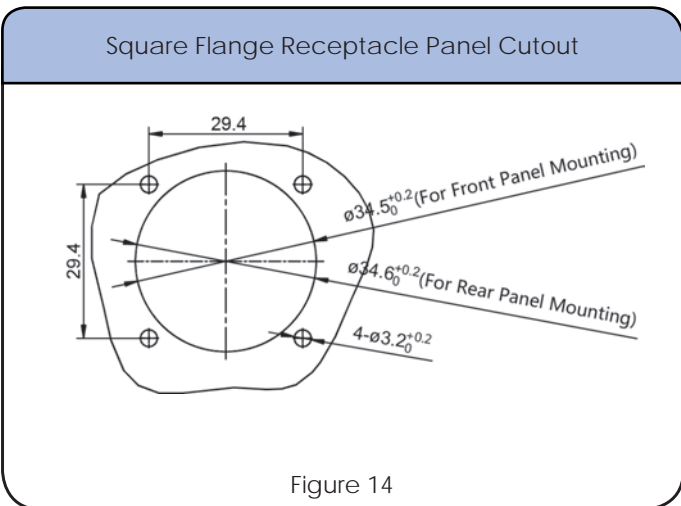
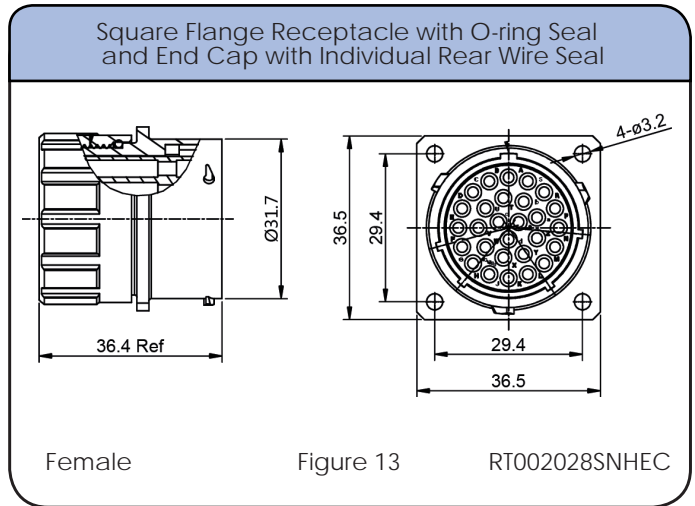
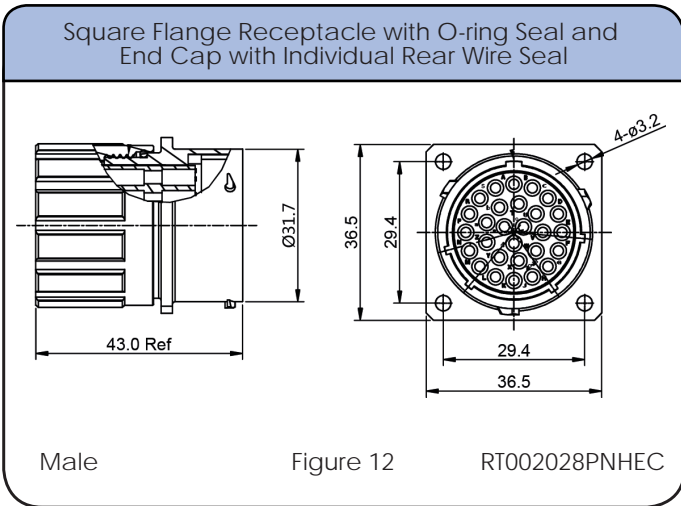
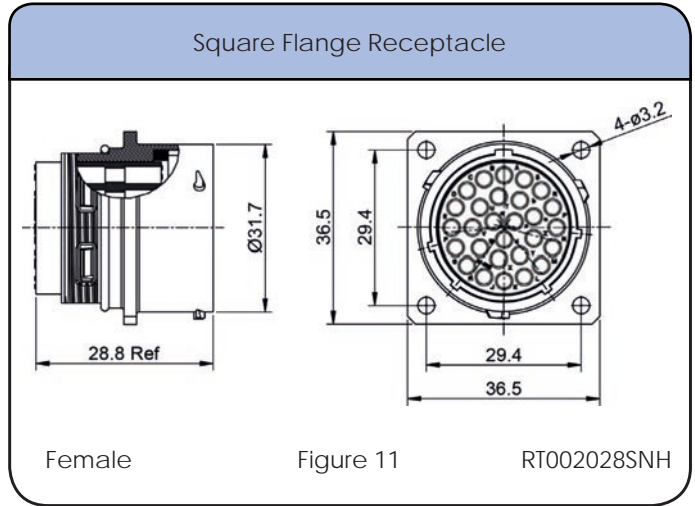
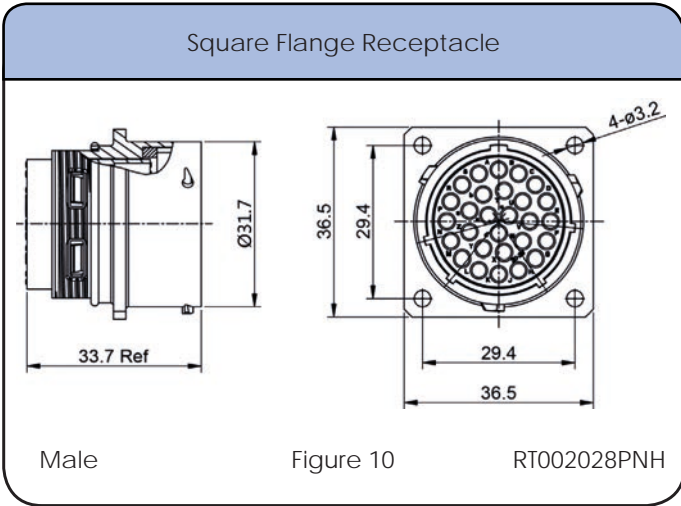

Shell Size: 20 Number of Contacts: 28 Contact Size: 16
Sealing: IP67 Salt Spray: 48h

Dimensions Backshell

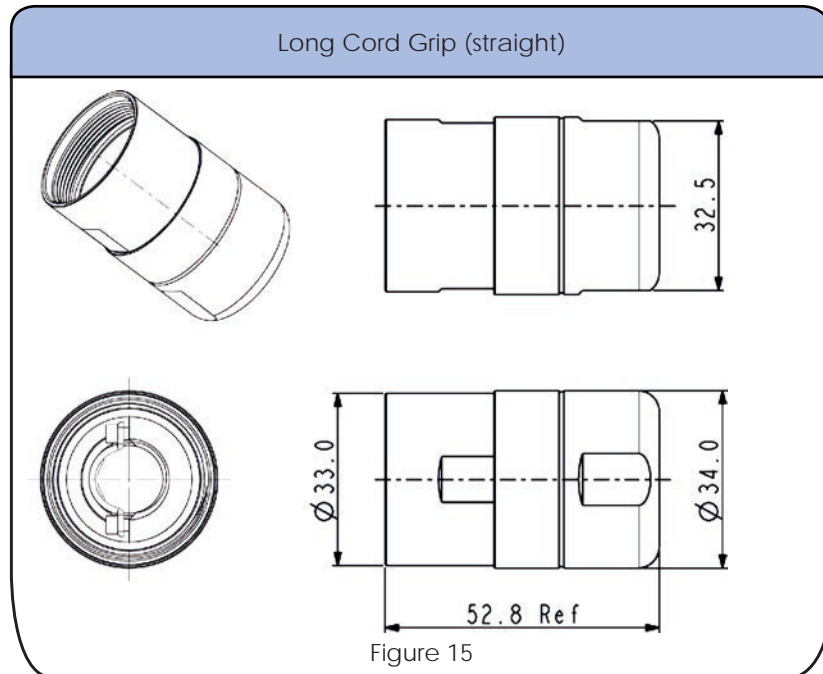

Accessories

<p>Locking Clip with Lanyard</p> <p>108039120</p>	<p>Plug Dustcap with Chain</p> <p>RT620DCG</p>	<p>Plug Dustcap without Chain</p> <p>RT620DC</p>	<p>Receptacle Dustcap with Chain</p> <p>RT020DCG</p>
<p>Receptacle Dustcap with Nylon Cord</p> <p>RT020RL</p>	<p>Receptacle Dustcap without Chain</p> <p>RT020DC</p>	<p>Receptacle Dustcap without Nylon Cord, Rubber Material</p> <p>RB00011920</p>	<p>Sealing Plug</p> <p>CA401659</p>
<p>Square Flange Receptacle Gaskets, Thickness 0.8mm (±0.2)</p> <p>RTFD20B</p>			

Shell Size: 20
Sealing: IP67

Number of Contacts: 28
Salt Spray: 48h

Contact Size: 16

Contacts



Crimp Contacts, Machined

Part Number		AWG	Wire Range	Plating
Male	Female			
MP14M23F	MS14M23F	14	2.0-2.5	Gold Flash
MP14M23G5	MS14M23G5	14	2.0-2.5	Gold 5 μ "
MP14M23G10	MS14M23G10	14	2.0-2.5	Gold 10 μ "
MP14M23G15	MS14M23G15	14	2.0-2.5	Gold 15 μ "
MP14M23G30	MS14M23G30	14	2.0-2.5	Gold 30 μ "
MP16M23F	MS16M23F	18-16	.75-1.5	Gold Flash
MP16M23G5	MS16M23G5	18-16	.75-1.5	Gold 5 μ "
MP16M23G10	MS16M23G10	18-16	.75-1.5	Gold 10 μ "
MP16M23G15	MS16M23G15	18-16	.75-1.5	Gold 15 μ "
MP16M23G30	MS16M23G30	18-16	.75-1.5	Gold 30 μ "
MP20M23F	MS20M23F	22-20	.34-.50	Gold Flash
MP20M23G5	MS20M23G5	22-20	.34-.50	Gold 5 μ "
MP20M23G10	MS20M23G10	22-20	.34-.50	Gold 10 μ "
MP20M23G15	MS20M23G15	22-20	.34-.50	Gold 15 μ "
MP20M23G30	MS20M23G30	22-20	.34-.50	Gold 30 μ "
MP24M23F	MS24M23F	26-24	.14-.25	Gold Flash
MP24M23G5	MS24M23G5	26-24	.14-.25	Gold 5 μ "
MP24M23G10	MS24M23G10	26-24	.14-.25	Gold 10 μ "
MP24M23G15	MS24M23G15	26-24	.14-.25	Gold 15 μ "
MP24M23G30	MS24M23G30	26-24	.14-.25	Gold 30 μ "

Tools

Contact Extraction Tool,
#16 (\varnothing 1.6) Contact



QXRT16

Hand Crimp Tool for
Machined Contacts



MFX-3959

Pneumatic Crimp Tool for
Machined Contacts



MFX-3960

Shell Size: 20 Number of Contacts: 28 Contact Size: 16
Sealing: IP67 Salt Spray: 48h

Contacts (con't)



Stamped & Formed Contacts

Crimp Contacts, Stamped & Formed

Part Number		AWG	Wire Range (mm ²)	Plating
Male	Female			
SP14M1F	SS14M1F	14	2.0-2.5	Gold Flash
SP14M1G5	SS14M1G5	14	2.0-2.5	Gold 5μ"
SP14M1G10	SS14M1G10	14	2.0-2.5	Gold 10μ"
SP14M1G15	SS14M1G15	14	2.0-2.5	Gold 15μ"
SP14M1G30	SS14M1G30	14	2.0-2.5	Gold 30μ"
SP16M1F	SS16M1F	18-16	.75-1.5	Gold Flash
SP16M1G5	SS16M1G5	18-16	.75-1.5	Gold 5μ"
SP16M1G10	SS16M1G10	18-16	.75-1.5	Gold 10μ"
SP16M1G15	SS16M1G15	18-16	.75-1.5	Gold 15μ"
SP16M1G30	SS16M1G30	18-16	.75-1.5	Gold 30μ"
SP20M1F	SS20M1F	22-20	.34-.50	Gold Flash
SP20M1G5	SS20M1G5	22-20	.34-.50	Gold 5μ"
SP20M1G10	SS20M1G10	22-20	.34-.50	Gold 10μ"
SP20M1G15	SS20M1G15	22-20	.34-.50	Gold 15μ"
SP20M1G30	SS20M1G30	22-20	.34-.50	Gold 30μ"
SP24M1F	SS24M1F	22-20	.14-.25	Gold Flash
SP24M1G5	SS24M1G5	26-24	.14-.25	Gold 5μ"
SP24M1G10	SS24M1G10	26-24	.14-.25	Gold 10μ"
SP24M1G15	SS24M1G15	26-24	.14-.25	Gold 15μ"
SP24M1G30	SS24M1G30	26-24	.14-.25	Gold 30μ"

Tools



Contact Extraction Tool, #16 (Ø 1.6) Contact

QXRT16



Hand Tool, Stamped & Formed Contact, Size 16, 20-14AWG

MFX-3954



Crimp Die for Stamped & Formed Contact

MFX-3957

STEP 1
Choose Receptacle Style

STEP 2
Choose Plug Style

STEP 2
Choose Backshell Style

Jam Nut Receptacles



Jam Nut Receptacle Kit Including Receptacle & Contacts



OR
Square Flange Receptacles



Square Flange Receptacle Kit Including Receptacle, Gasket & Contacts



Plug



Backshell



OR

Plug Kit Including Connector, Backshell & Contacts



SEE TABLE ON NEXT PAGE FOR PART DETAILS

CONTACTS SOLD SEPARATELY SEE PAGE 172

Shell Size: 18 Number of Contacts: 32
 Sealing: IP67 Salt Spray: 48h

Contact Size: 20

Dimensions Jam Nut Receptacle

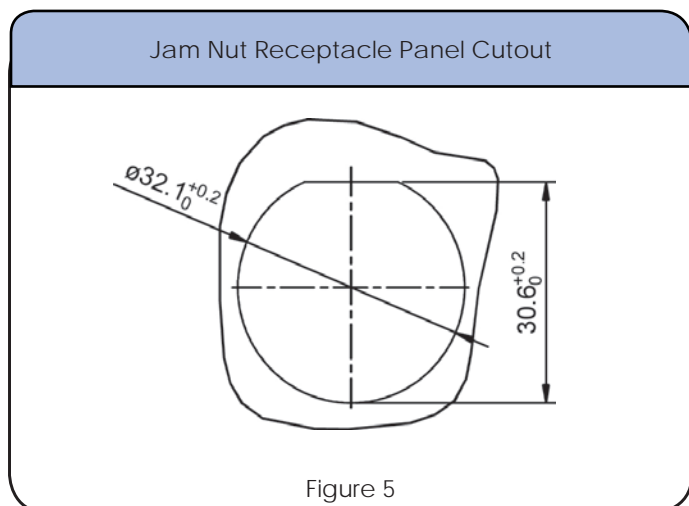
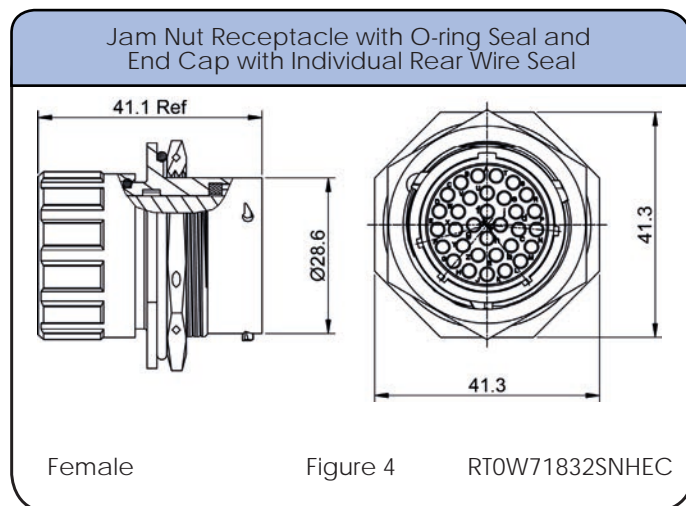
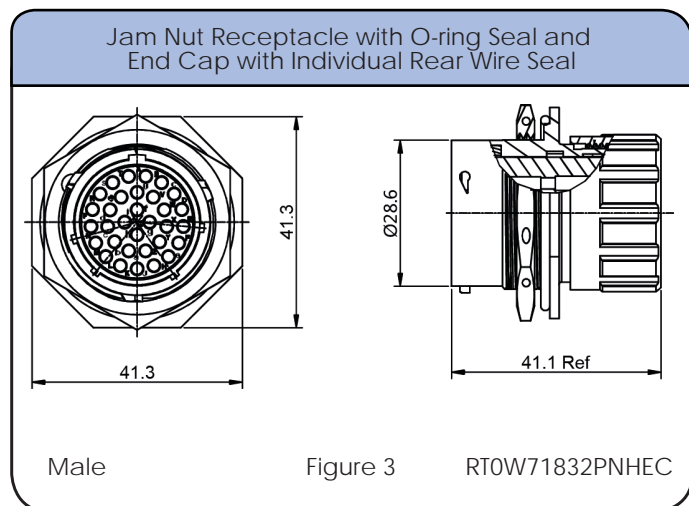
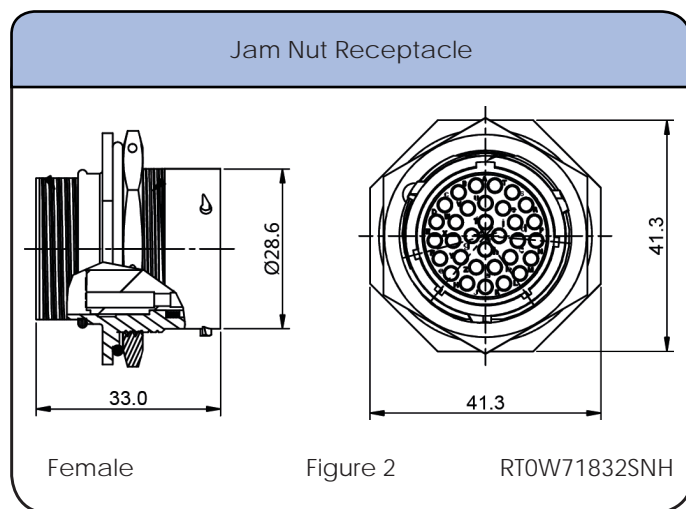
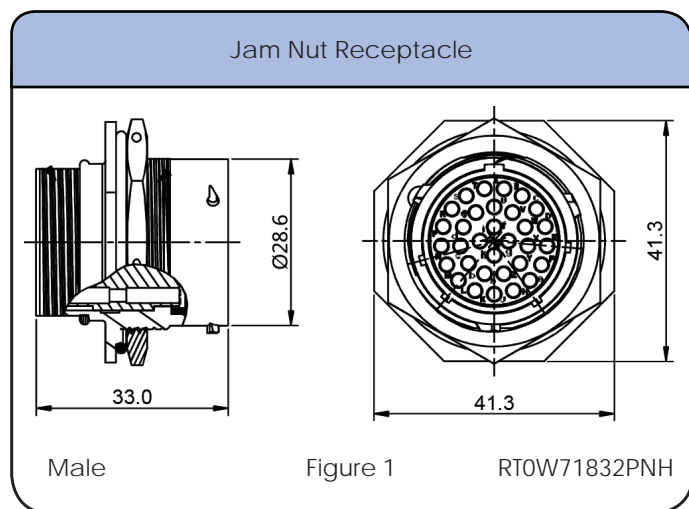

Shell Size: 18 Number of Contacts: 32 Contact Size: 20
Sealing: IP67 Salt Spray: 48h

Dimensions Plug

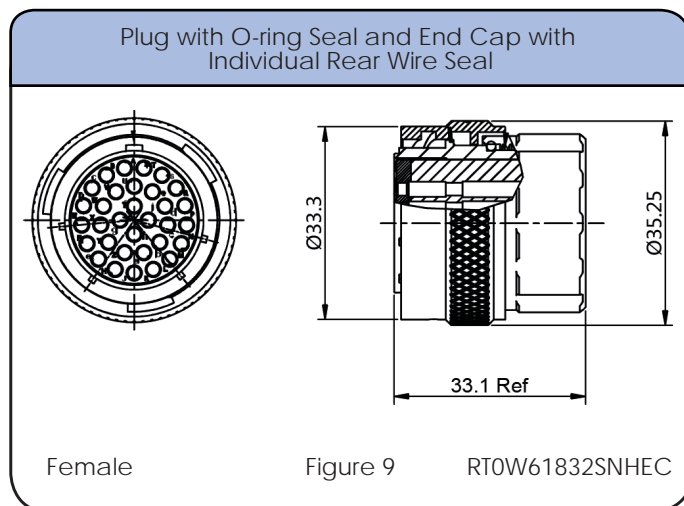
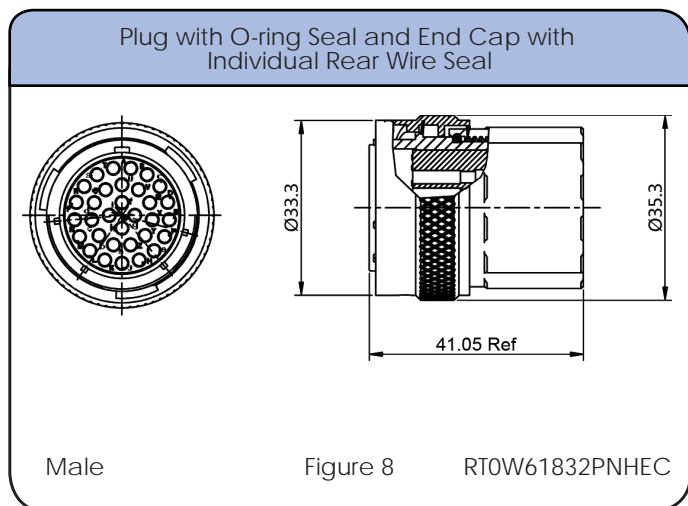
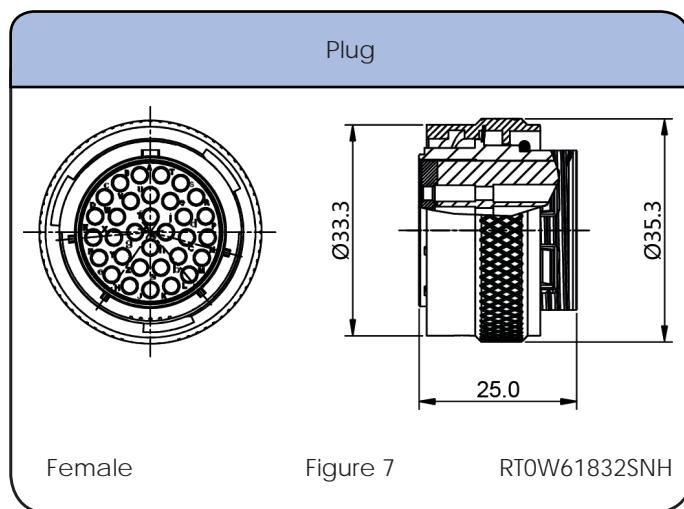
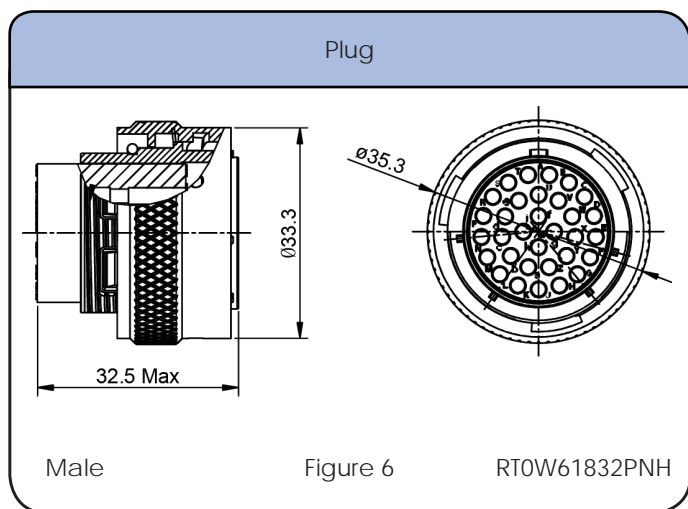

Individual Sealing Wire Range

Contact Size	Insulation Overall Diameter (min-max)	Wire Range
20	Ø1.6mm - Ø2.6mm	20 - 30 AWG

Shell Size: 18 Number of Contacts: 32 Contact Size: 20
 Sealing: IP67 Salt Spray: 48h

Dimensions Square Flange Receptacle

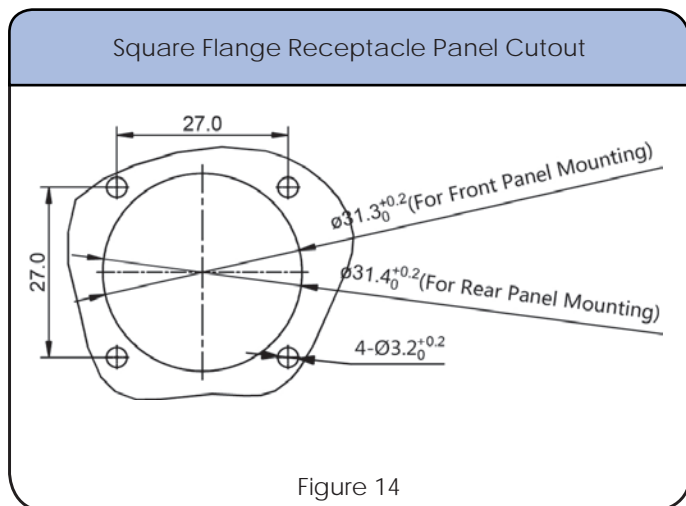
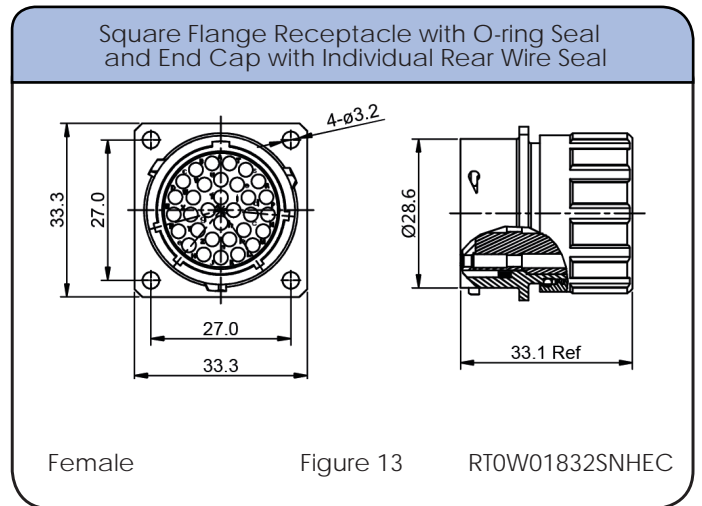
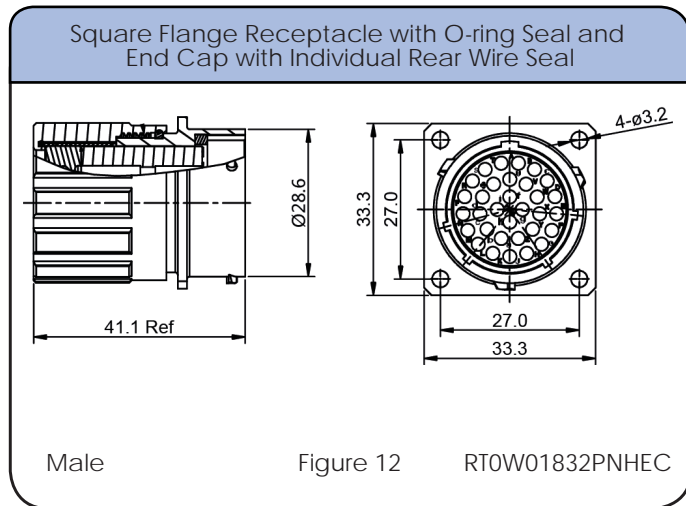
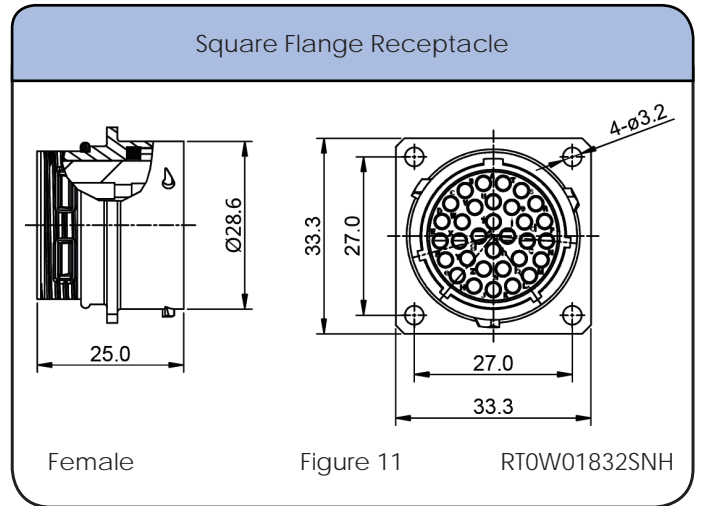
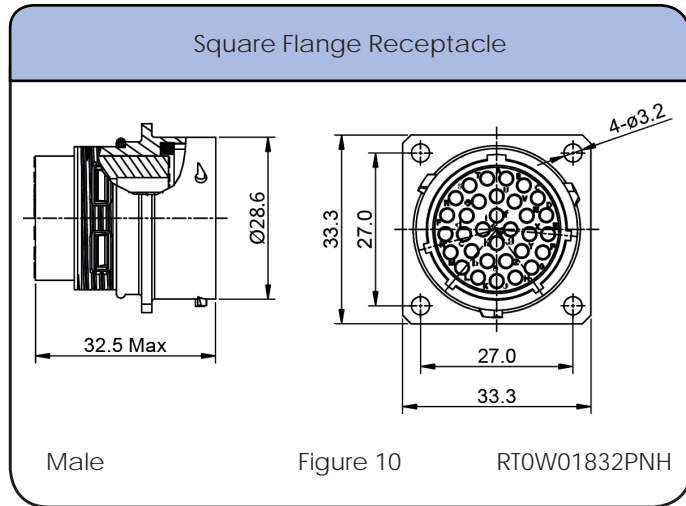

Shell Size: 18 Number of Contacts: 32 Contact Size: 20
Sealing: IP67 Salt Spray: 48h

Dimensions Backshell

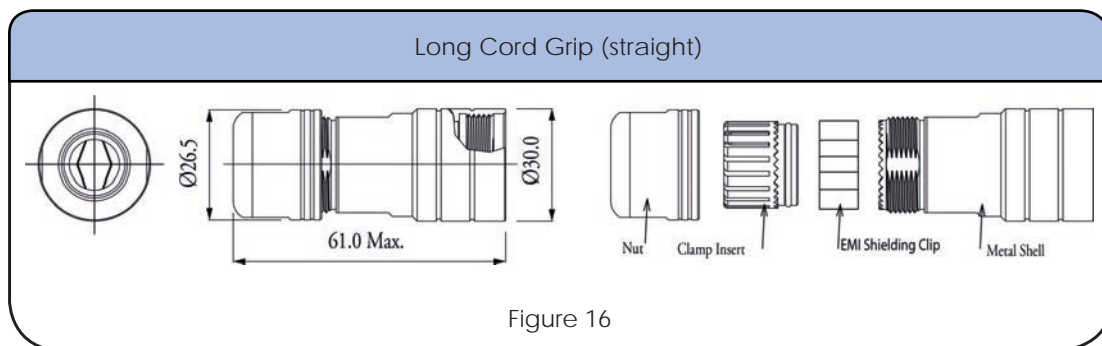
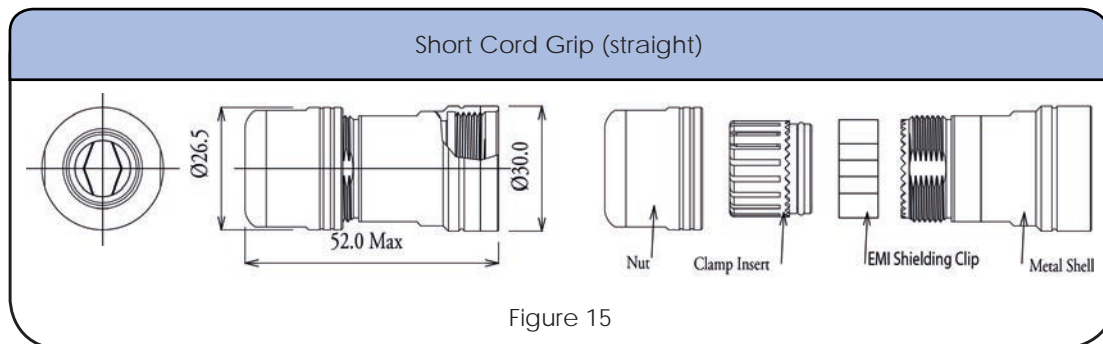

Accessories

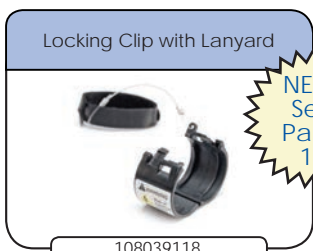
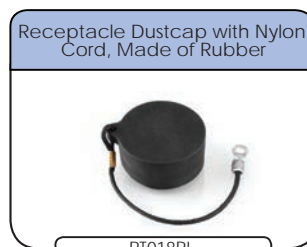
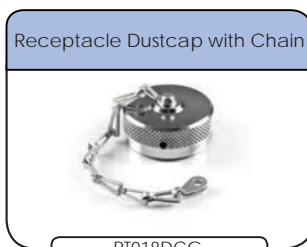

NEW!
See
Page
16

Shell Size: 18
Sealing: IP67

Number of Contacts: 32
Salt Spray: 48h

Contact Size: 20

Contacts



Crimp Contacts, Machined (7.5A Max)

PART NUMBER		AWG	Wire Range (mm ²)	Plating
MALE	FEMALE			
MP20W23F	MS20W23F	22-20	.34-.50	Gold Flash
MP20W23G5	MS20W23G5	22-20	.34-.50	Gold 5μ"
MP20W23G10	MS20W23G10	22-20	.34-.50	Gold 10μ"
MP20W23G15	MS20W23G15	22-20	.34-.50	Gold 15μ"
MP20W23G30	MS20W23G30	22-20	.34-.50	Gold 30μ"
MP24W23F	MS24W23F	26-24	.13-.25	Gold Flash
MP24W23G5	MS24W23G5	26-24	.13-.25	Gold 5μ"
MP24W23G10	MS24W23G10	26-24	.13-.25	Gold 10μ"
MP24W23G15	MS24W23G15	26-24	.13-.25	Gold 15μ"
MP24W23G30	MS24W23G30	26-24	.13-.25	Gold 30μ"
MP28W23F	MS28W23F	30-28	.05-.08	Gold Flash
MP28W23G5	MS28W23G5	30-28	.05-.08	Gold 5μ"
MP28W23G10	MS28W23G10	30-28	.05-.08	Gold 10μ"
MP28W23G15	MS28W23G15	30-28	.05-.08	Gold 15μ"
MP28W23G30	MS28W23G30	30-28	.05-.08	Gold 30μ"

Tools



Shell Size: 18 Number of Contacts: 32 Contact Size: 20
Sealing: IP67 Salt Spray: 48h

Contacts (con't)



Stamped & Formed Contacts

Crimp Contacts, Stamped & Formed (5A Max)

PART NUMBER		AWG	Wire Range (mm ²)	Plating
MALE	FEMALE			
SP20W1F	SS20W1F	22-20	.34-.50	Gold Flash
SP20W1G5	SS20W1G5	22-20	.34-.50	Gold 5μ"
SP20W1G10	SS20W1G10	22-20	.34-.50	Gold 10μ"
SP20W1G15	SS20W1G15	22-20	.34-.50	Gold 15μ"
SP20W1G30	SS20W1G30	22-20	.34-.50	Gold 30μ"
SP24W1F	SS24W1F	26-24	.14-.25	Gold Flash
SP24W1G5	SS24W1G5	26-24	.14-.25	Gold 5μ"
SP24W1G10	SS24W1G10	26-24	.14-.25	Gold 10μ"
SP24W1G15	SS24W1G15	26-24	.14-.25	Gold 15μ"
SP24W1G30	SS24W1G30	26-24	.14-.25	Gold 30μ"
SP28W1F	SS28W1F	30-28	.05-.08	Gold Flash
SP28W1G5	SS28W1G5	30-28	.05-.08	Gold 5μ"
SP28W1G10	SS28W1G10	30-28	.05-.08	Gold 10μ"
SP28W1G15	SS28W1G15	30-28	.05-.08	Gold 15μ"
SP28W1G30	SS28W1G30	30-28	.05-.08	Gold 30μ"

Tools



Shell Size: 24 Number of Contacts: 48 Contact Size: 16
 Sealing: IP67 Salt Spray: 48h



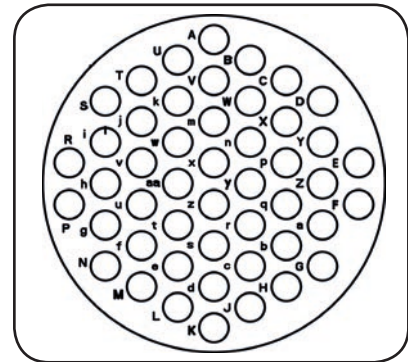

eco | mate[®] rm Standard Products

- Suitable For Indoor and Outdoor Applications
- EMI/RMI Shielding Capability with Appropriate Backshell
- Operating Temperature: -40°C to +105°C
- 500 Mating Cycles
- Contacts and Cord Grips Ordered Separately
- UL ECBT2 Certified*

An upgraded silicone seal is available for all connector parts. Please add "03" to the end of the part number when ordering. Operating Temperature: -40°C to +125°C. Not available in kits.

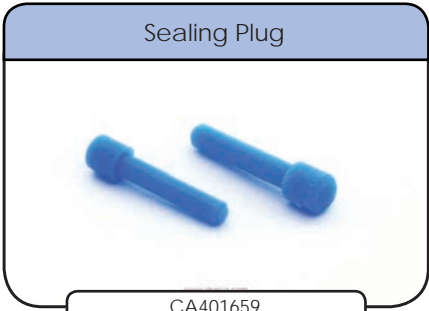
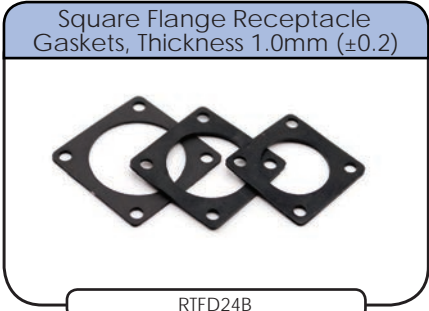

Insert Arrangement
 Pin (Male) Faceview

STEP 1 Choose Receptacle Style		STEP 2 Choose Plug Style		Accessories	
Square Flange Receptacles 		Plug 		Sealing Plug 	
				Square Flange Receptacle Gaskets, Thickness 1.0mm (±0.2) 	
				Locking Clip with Lanyard 	

Connector Part Numbers

Part Number		Connector Type	Figure Drawings	
Male	Female		Male	Female
RT062448PNH	RT062448SNH	Plug	1	2
RT002448PNH	RT002448SNH	Square Flange Receptacle	3,5	4,5

Contacts supplied separately see page 176

CONTACTS SOLD SEPARATELY SEE PAGE 176

Shell Size: 24 Number of Contacts: 48
Sealing: IP67 Salt Spray: 48h

Contact Size: 16

Dimensions Plug

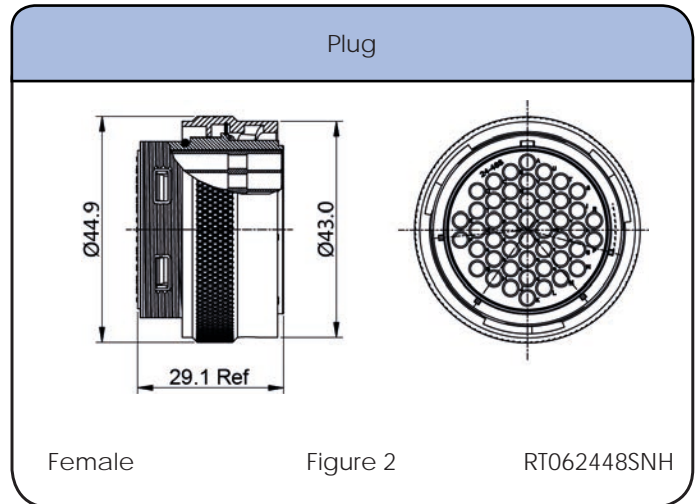
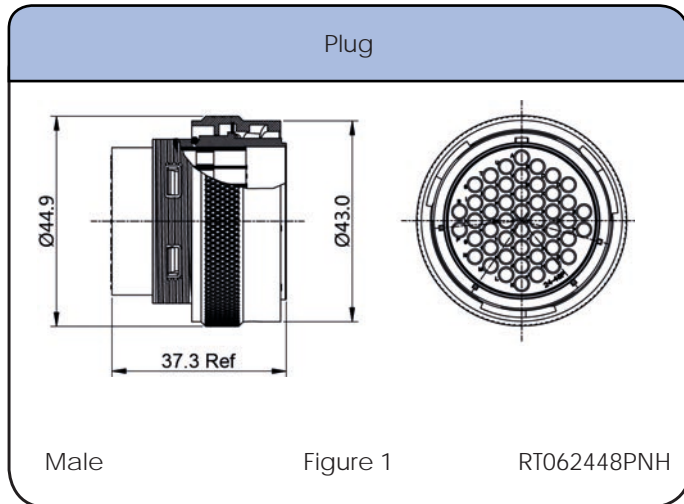

Dimensions Square Flange Receptacle

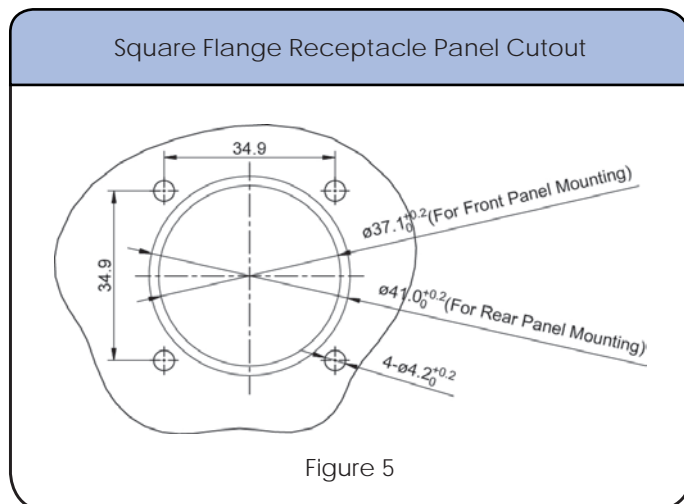
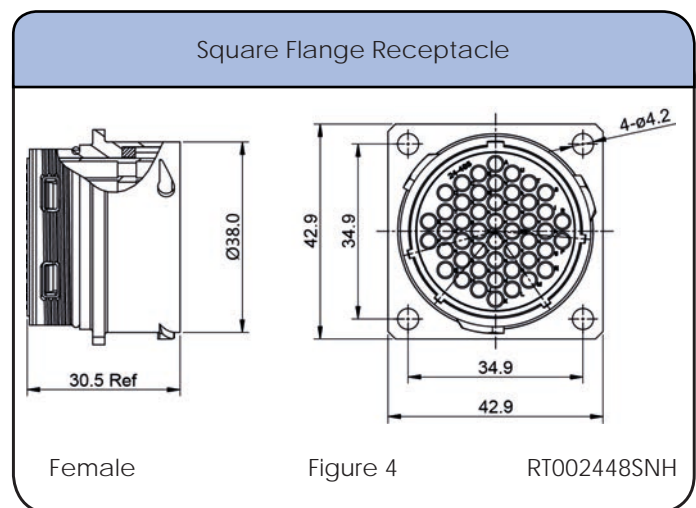
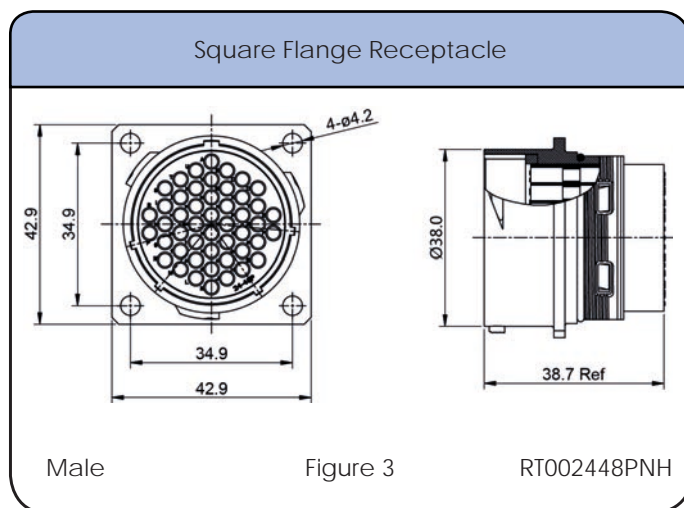

Shell Size: 24
Sealing: IP67

Number of Contacts: 48
Salt Spray: 48h

Contact Size: 16

Contacts



Crimp Contacts, Machined

Part Number		AWG	Wire Range (mm ²)	Plating
Male	Female			
MP14M23F	MS14M23F	14	2.0-2.5	Gold Flash
MP14M23G5	MS14M23G5	14	2.0-2.5	Gold 5μ"
MP14M23G10	MS14M23G10	14	2.0-2.5	Gold 10μ"
MP14M23G15	MS14M23G15	14	2.0-2.5	Gold 15μ"
MP14M23G30	MS14M23G30	14	2.0-2.5	Gold 30μ"
MP16M23F	MS16M23F	18-16	.75-1.5	Gold Flash
MP16M23G5	MS16M23G5	18-16	.75-1.5	Gold 5μ"
MP16M23G10	MS16M23G10	18-16	.75-1.5	Gold 10μ"
MP16M23G15	MS16M23G15	18-16	.75-1.5	Gold 15μ"
MP16M23G30	MS16M23G30	18-16	.75-1.5	Gold 30μ"
MP20M23F	MS20M23F	22-20	.34-.50	Gold Flash
MP20M23G5	MS20M23G5	22-20	.34-.50	Gold 5μ"
MP20M23G10	MS20M23G10	22-20	.34-.50	Gold 10μ"
MP20M23G15	MS20M23G15	22-20	.34-.50	Gold 15μ"
MP20M23G30	MS20M23G30	22-20	.34-.50	Gold 30μ"
MP24M23F	MS24M23F	26-24	.14-.25	Gold Flash
MP24M23G5	MS24M23G5	26-24	.14-.25	Gold 5μ"
MP24M23G10	MS24M23G10	26-24	.14-.25	Gold 10μ"
MP24M23G15	MS24M23G15	26-24	.14-.25	Gold 15μ"
MP24M23G30	MS24M23G30	26-24	.14-.25	Gold 30μ"

Tools



Shell Size: 24 Number of Contacts: 48 Contact Size: 16
Sealing: IP67 Salt Spray: 48h

Contacts (con't)



Stamped & Formed Contacts

Crimp Contacts, Stamped & Formed

Part Number		AWG	Wire Range (mm ²)	Plating
Male	Female			
SP14M1F	SS14M1F	14	2.0-2.5	Gold Flash
SP14M1G5	SS14M1G5	14	2.0-2.5	Gold 5μ"
SP14M1G10	SS14M1G10	14	2.0-2.5	Gold 10μ"
SP14M1G15	SS14M1G15	14	2.0-2.5	Gold 15μ"
SP14M1G30	SS14M1G30	14	2.0-2.5	Gold 30μ"
SP16M1F	SS16M1F	18-16	.75-1.5	Gold Flash
SP16M1G5	SS16M1G5	18-16	.75-1.5	Gold 5μ"
SP16M1G10	SS16M1G10	18-16	.75-1.5	Gold 10μ"
SP16M1G15	SS16M1G15	18-16	.75-1.5	Gold 15μ"
SP16M1G30	SS16M1G30	18-16	.75-1.5	Gold 30μ"
SP20M1F	SS20M1F	22-20	.34-.50	Gold Flash
SP20M1G5	SS20M1G5	22-20	.34-.50	Gold 5μ"
SP20M1G10	SS20M1G10	22-20	.34-.50	Gold 10μ"
SP20M1G15	SS20M1G15	22-20	.34-.50	Gold 15μ"
SP20M1G30	SS20M1G30	22-20	.34-.50	Gold 30μ"
SP24M1F	SS24M1F	22-20	.14-.25	Gold Flash
SP24M1G5	SS24M1G5	26-24	.14-.25	Gold 5μ"
SP24M1G10	SS24M1G10	26-24	.14-.25	Gold 10μ"
SP24M1G15	SS24M1G15	26-24	.14-.25	Gold 15μ"
SP24M1G30	SS24M1G30	26-24	.14-.25	Gold 30μ"

Tools



Contact Extraction Tool, #16 (Ø 1.6) Contact

QXRT16



Hand Tool, Stamped & Formed Contact, Size 16, 20-14AWG

MFX-3954



Crimp Die for Stamped & Formed Contact

MFX-3957

STEP 1
Choose Receptacle Style

STEP 2
Choose Plug Style

Square Flange
Receptacles



RTHP0121PN-16C



RTHP0121PN-H1

Plug



RTHP6121SNH-16S2



RTHP6121SNH16-BS2



Crimp Barrel Contact



Flat Hole Tail Contact
(receptacle only)



Screw Tail Contact
(receptacle only)



SEE TABLE ON NEXT PAGE FOR PART DETAILS

CONTACTS INCLUDED SEE PAGE 179

Shell Size: 12 Number of Contacts: 1 Contact Size: 3.6mm
Sealing: IP67 Salt Spray: 48h

High Amperage eco | mate[®] rm with RADSOK[®] Technology

- Single Pole High Power Arrangements
- 3.6mm Contact Size
- Operating Temperature: -40°C to +125°C
- RoHS Compliant
- Operating Voltage: 630V
- Current Rating at 25°C: 86A
- Flammability Rating: UL94-V0
- High Reliability
- Low Contact Engagement / Separation Forces
- Low Contact Resistance
- High Mating Cycle Durability

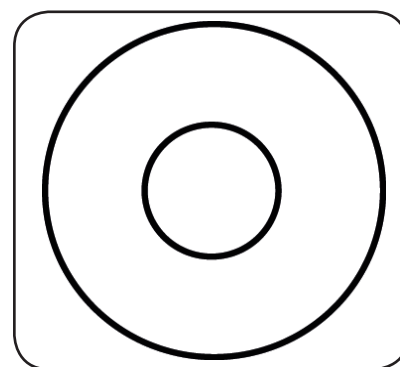

Insert Arrangement
Pin (Male) Faceview

Connector Part Numbers

Connector Part Number	Connector Type	Wire Range (mm ²)	Amps	Contact				Figure Drawings
				Part Number	Type	AWG	Plating	
RTHP6121SNH-16S2	Female Plug Straight, Crimp, with Long Shielded Backshell	10-16	86	MS6ARS8S	Crimp Barrel, Female	8	Silver	1
RTHP6121SNH16-BS2	Female Plug with 90° Shielded Backshell	10-16	86	MS6ARS8S	Crimp Barrel, Female	8	Silver	2
RTHP0121PN-16C	Male Square Flange Receptacle Crimp	10-16	86	MP6ARS8S	Crimp Barrel, Male	8	Silver	3,5
RTHP0121PN-H1	Male Square Flange Receptacle Flat Tail	N/A	86	HPAHS	Flathole Tail, Male	8	Silver	3,5

Contacts included. See chart for specific requirements

Shell Size: 12 Number of Contacts: 1
 Sealing: IP67 Salt Spray: 48h

Contact Size: 3.6mm

Dimensions Plug

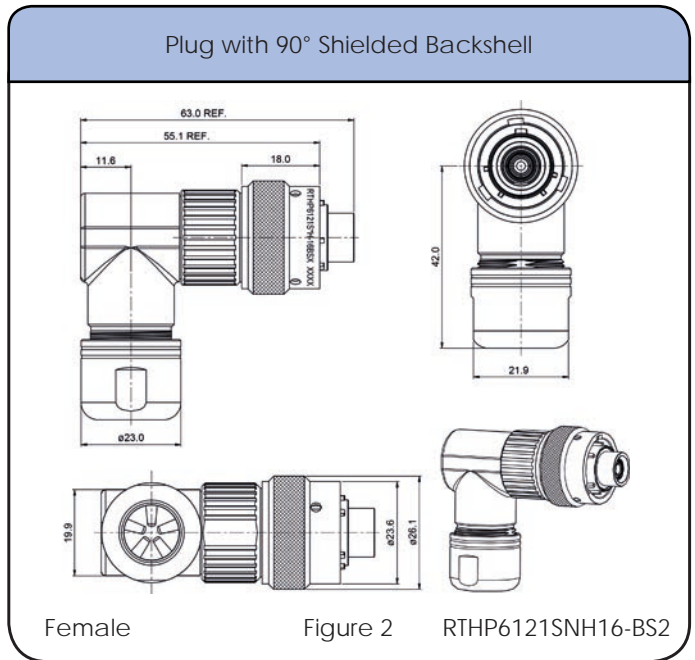
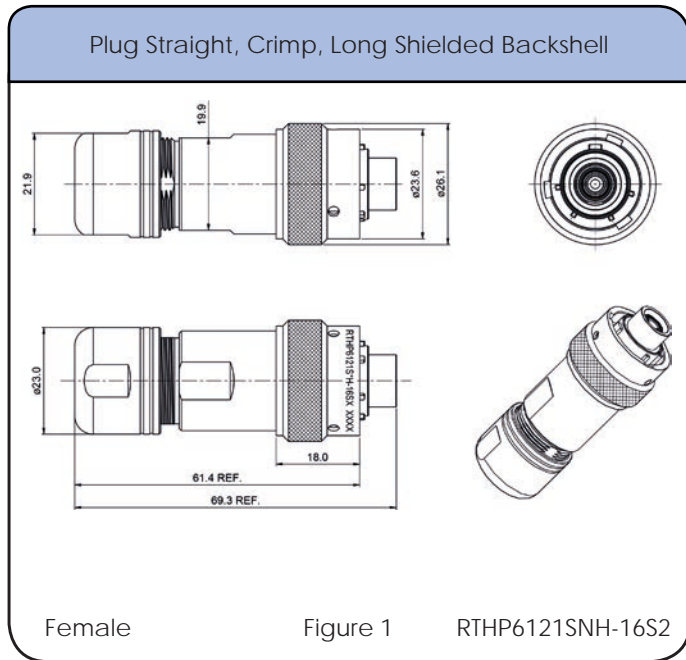

Shell Size: 12 Number of Contacts: 1 Contact Size: 3.6mm
 Sealing: IP67 Salt Spray: 48h

Dimensions Square Flange Receptacle

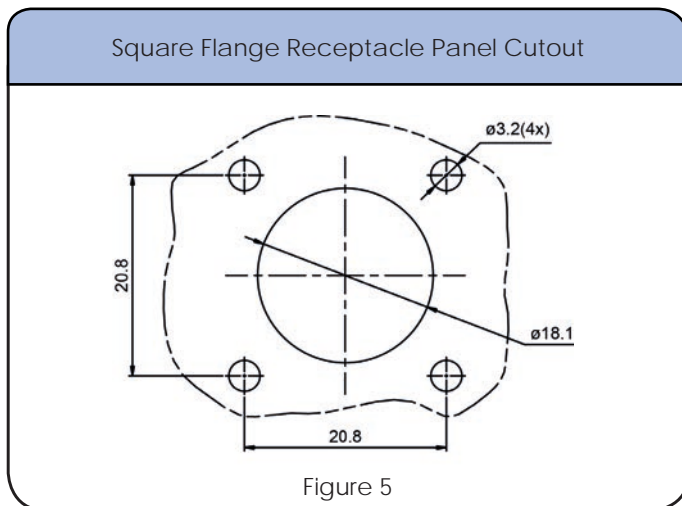
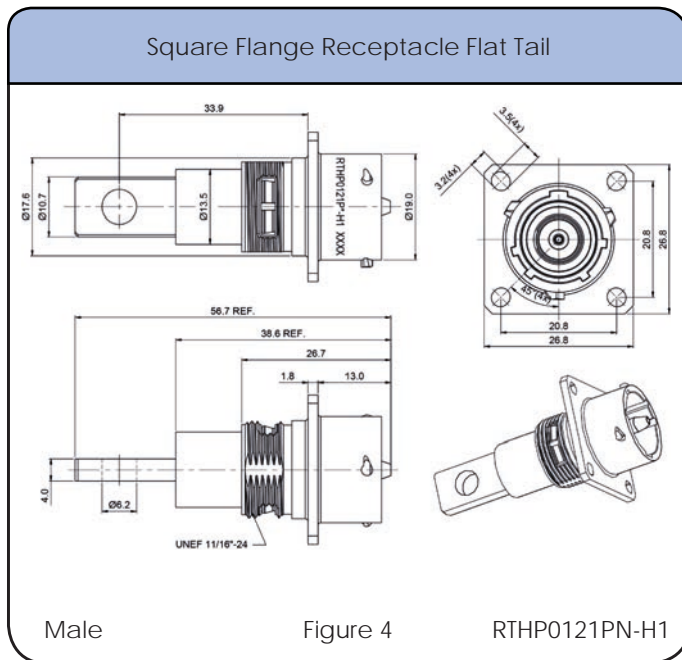
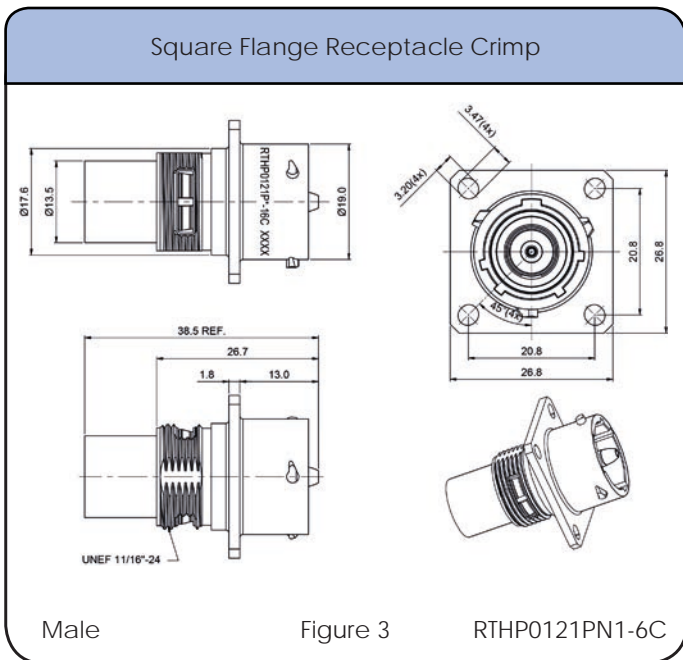

STEP 1
Choose Receptacle Style

STEP 2
Choose Plug Style

Square Flange Receptacles



RTHP0141PN-25C



RTHP0141PN-H1



RTHP0141PN-M1

Plug

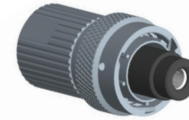

RTHP6141SNH25-EC



RTHP6141SNH25-PS2



RTHP6141SNH-25S2



RTHP6141SNH25-BS2



Crimp Barrel Contact



Flat Hole Tail Contact
(receptacle only)



Screw Tail Contact
(receptacle only)



SEE TABLE ON NEXT PAGE FOR PART DETAILS

CONTACTS INCLUDED SEE PAGE 183

Shell Size: 14 Number of Contacts: 1 Contact Size: 6mm
Sealing: IP67 Salt Spray: 48h

High Amperage eco | mate[®] rm with RADSOK[®] Technology

- Single Pole High Power Arrangements
- 6mm Contact Size
- Operating Temperature: -40°C to +125°C
- RoHS Compliant
- Operating Voltage: 630V
- Current Rating at 25°C: 120A
- Flammability Rating: UL94-V0
- High Reliability
- Low Contact Engagement / Separation Forces
- Low Contact Resistance
- High Mating Cycle Durability

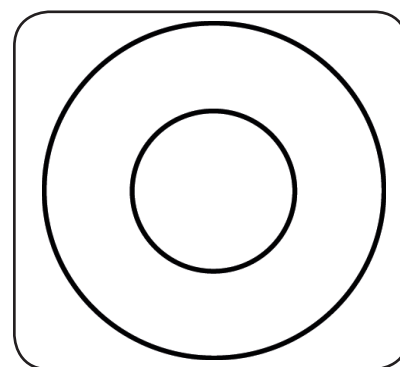

Insert Arrangement
Pin (Male) Faceview

Connector Part Numbers

Connector Part Number	Connector Type	Wire Range (mm ²)	Amps	Contact				Figure Drawings
				Part Number	Type	AWG	Plating	
RTHP6141SNH25-EC	Female Plug with Unshielded Short Backshell and End Cap with Individual Rear Wire Seal	20-25	120	HS25BCS	Crimp Barrel, Female	4	Silver	1
RTHP6141SNH25-PS2	Female Plug with Short Shielded Backshell	20-25	120	HS25BCS	Crimp Barrel, Female	4	Silver	2
RTHP6141SNH-25S2	Female Plug Straight, Crimp, Long Shielded Backshell	20-25	120	HS25BCS	Crimp Barrel, Female	4	Silver	3
RTHP6141SNH25-BS2	Female Plug with 90° Shielded Backshell	20-25	120	HS25BCS	Crimp Barrel, Female	4	Silver	4
RTHP0141PN-25C	Male Square Flange Receptacle Crimp	20-25	120	HP25BCS	Crimp Barrel, Male	4	Silver	5,8
RTHP0141PN-H1	Male Square Flange Receptacle Flat Tail	N/A	120	HPBHS	Flathole Tail, Male	4	Silver	6,8
RTHP0141PN-M1	Male Square Flange Receptacle with Screw Tail	N/A	120	HPBSS	Screw Tail, Male	4	Silver	7,8

Contacts included. See chart for specific requirements

Shell Size: 14 Number of Contacts: 1
 Sealing: IP67 Salt Spray: 48h

Contact Size: 6mm

Dimensions Plug

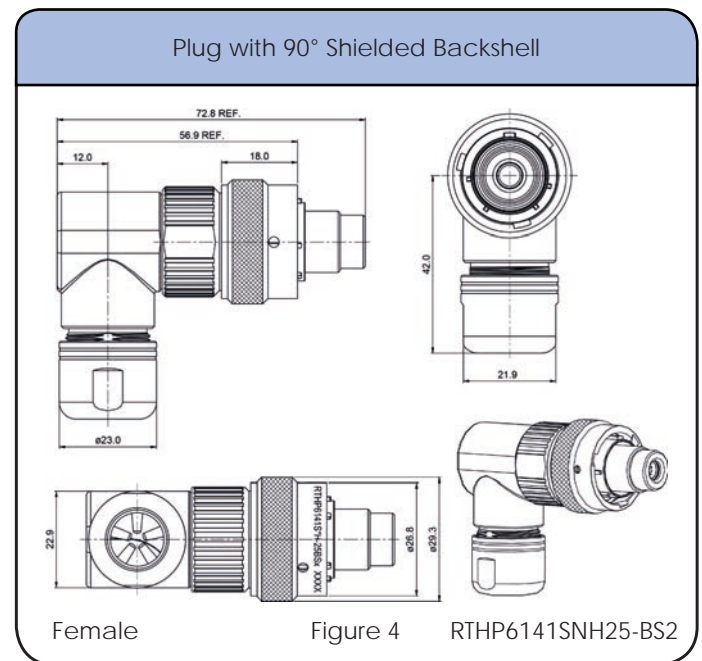
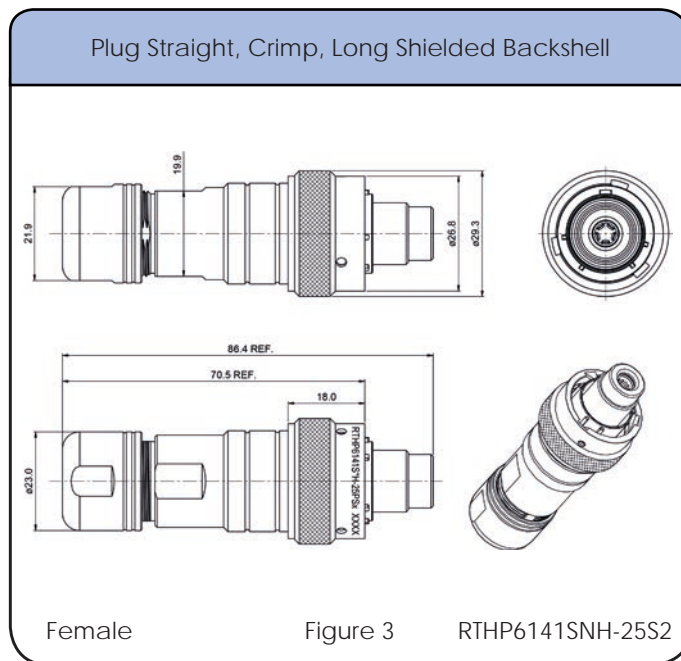
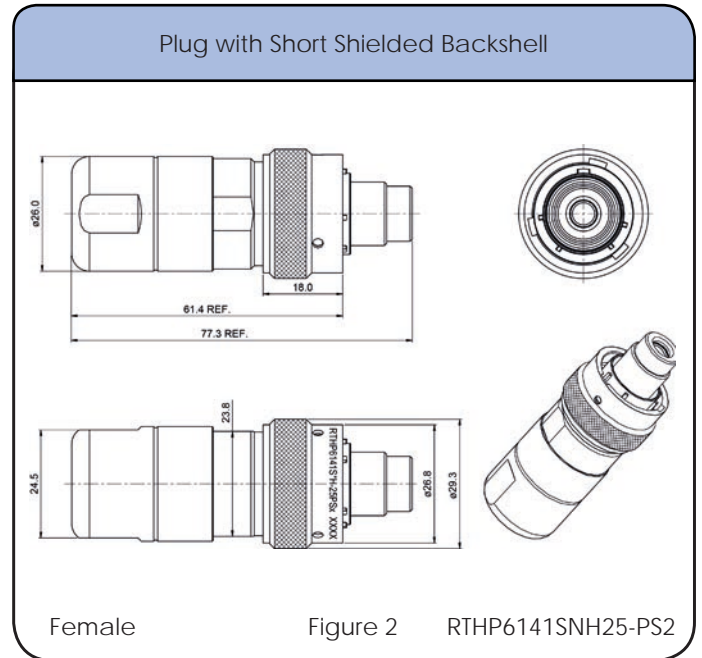
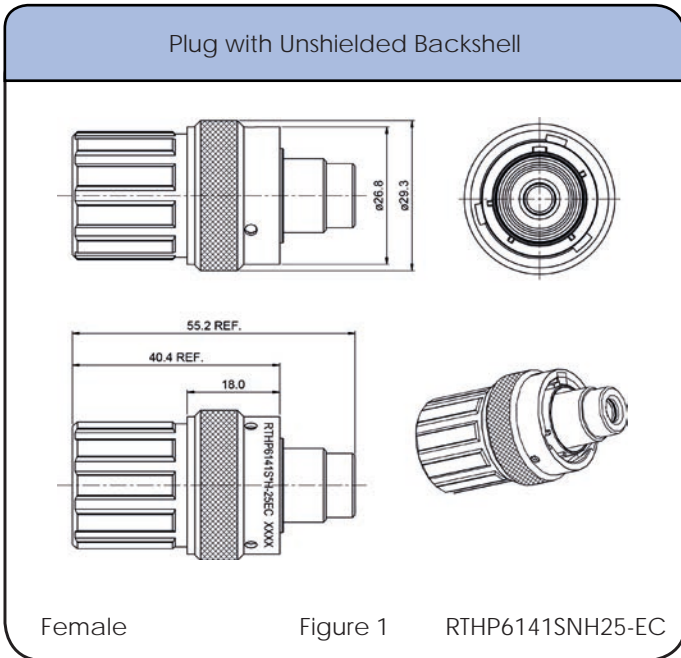

Shell Size: 14 Number of Contacts: 1 Contact Size: 6mm
Sealing: IP67 Salt Spray: 48h

Dimensions Square Flange Receptacle

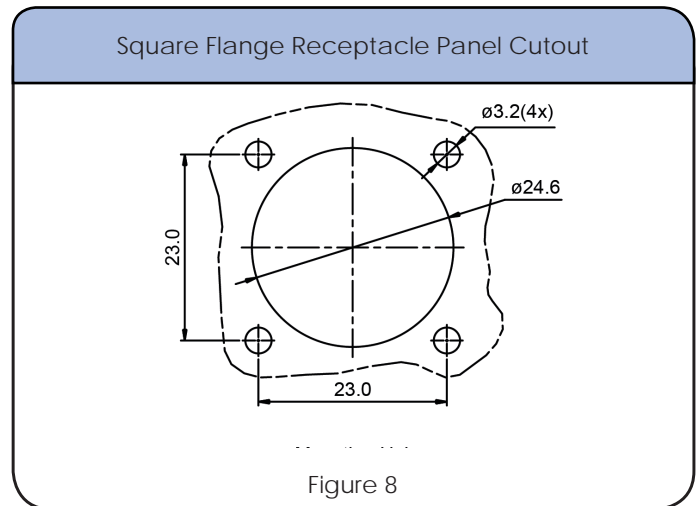
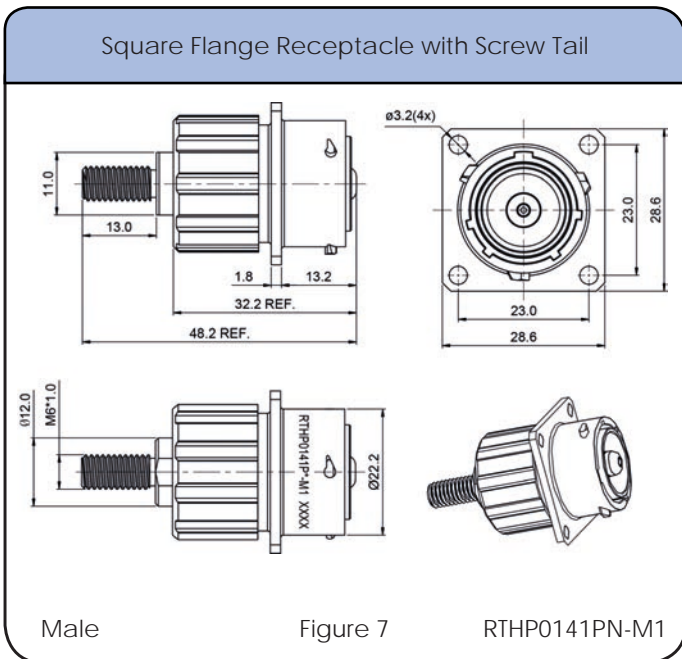
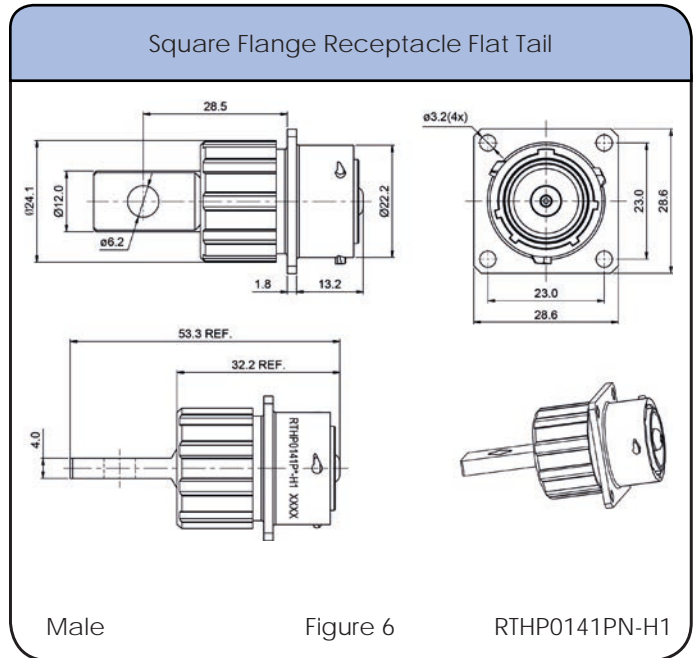
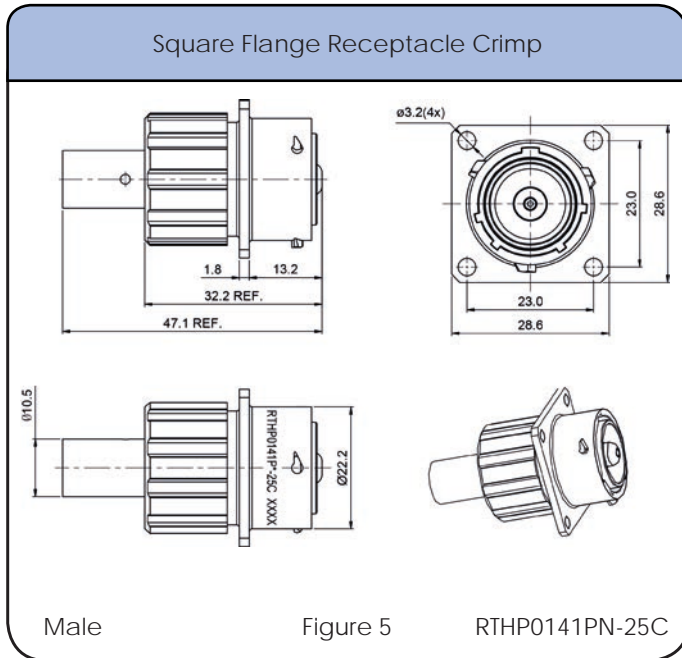

STEP 1
Choose Receptacle Style

STEP 2
Choose Plug Style

Square Flange Receptacles

Plug



RTHP0161PN-35C



RTHP0161PN-50C



RTHP0161PN-H1



RTHP0161PN-M1



RTHP6161SNH25-PS3



RTHP6161SNH35-PS2



RTHP6161SNH50-PS2



RTHP6161SNH-35S2



Crimp Barrel Contact



Flat Hole Tail Contact
(receptacle only)



Screw Tail Contact
(receptacle only)



SEE TABLE ON NEXT PAGE FOR PART DETAILS

CONTACTS INCLUDED SEE PAGE 187

Shell Size: 16 Number of Contacts: 1 Contact Size: 8mm
Sealing: IP67 Salt Spray: 48h

High Amperage eco | mate[®] rm with RADSOK[®] Technology

- Single Pole High Power Arrangements
- 8mm Contact Size
- Operating Temperature: -40°C to +125°C
- RoHS Compliant
- Operating Voltage: 630V
- Current Rating at 25°C: 180A
- Flammability Rating: UL94-V0
- High Reliability
- Low Contact Engagement / Separation Forces
- Low Contact Resistance
- High Mating Cycle Durability

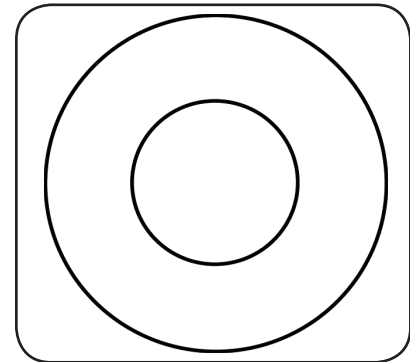

Insert Arrangement
Pin (Male) Faceview

Connector Part Numbers

Connector Part Number	Connector Type	Wire Range (mm ²)	Amps	Contact				Figure Drawings
				Part Number	Type	AWG	Plating	
RTHP6161SNH25-PS3	Female Plug with Short Shielded Backshell	20-25	120	HS25CCS	Crimp Barrel, Female	4	Silver	1
RTHP6161SNH35-PS2	Female Plug with Short Shielded Backshell	30-35	130	HS35CCS	Crimp Barrel, Female	2	Silver	2
RTHP6161SNH50-PS2	Female Plug with Short Shielded Backshell	45-50	180	HS50CCS	Crimp Barrel, Female	2	Silver	3
RTHP6161SNH-35S2	Female Plug Straight, Crimp, Long Shielded Backshell	30-35	130	HS35CCS	Crimp Barrel, Female	2	Silver	4
RTHP0161PN-35C	Male Square Flange Receptacle Crimp	30-35	130	HP35CCS	Crimp Barrel, Male	2	Silver	5,9
RTHP0161PN-50C	Male Square Flange Receptacle with Crimp	40-50	130	HP50CCS	Crimp Barrel, Male	2	Silver	6,9
RTHP0161PN-H1	Male Square Flange Receptacle Flat Tail	N/A	180	HPCHS	Flathole Tail, Male	N/A	Silver	7,9
RTHP0161PN-M1	Male Square Flange Receptacle with Screw Tail	N/A	180	HPCSS	Screw Tail, Male	N/A	Silver	8,9

Contacts included. See chart for specific requirements

Shell Size: 16
Sealing: IP67

Number of Contacts: 1
Salt Spray: 48h

Contact Size: 8mm

Dimensions Plug

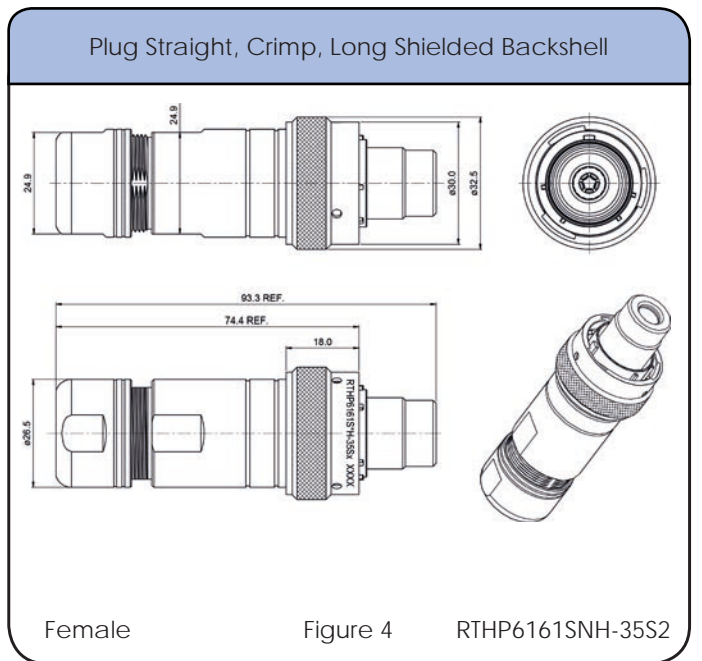
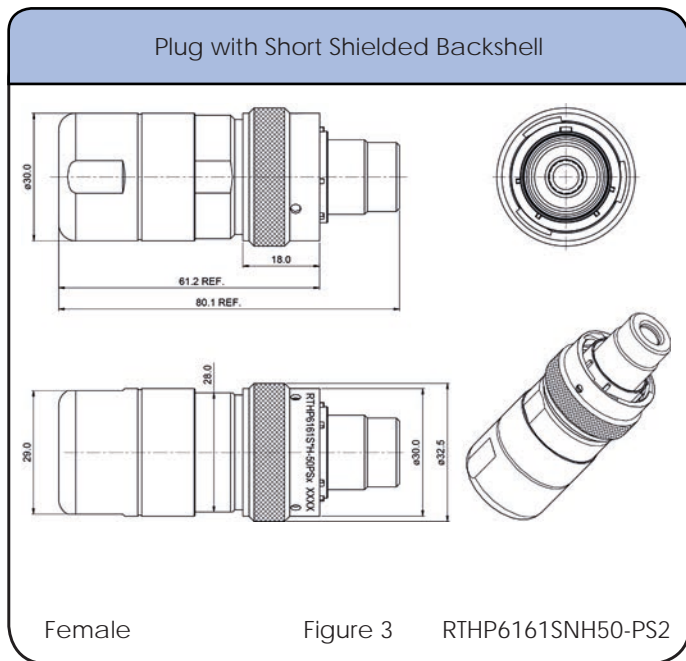
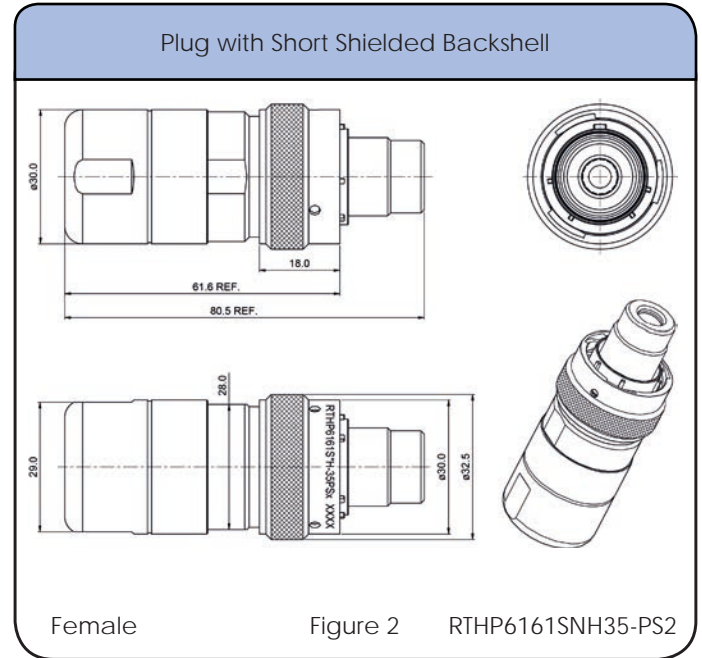
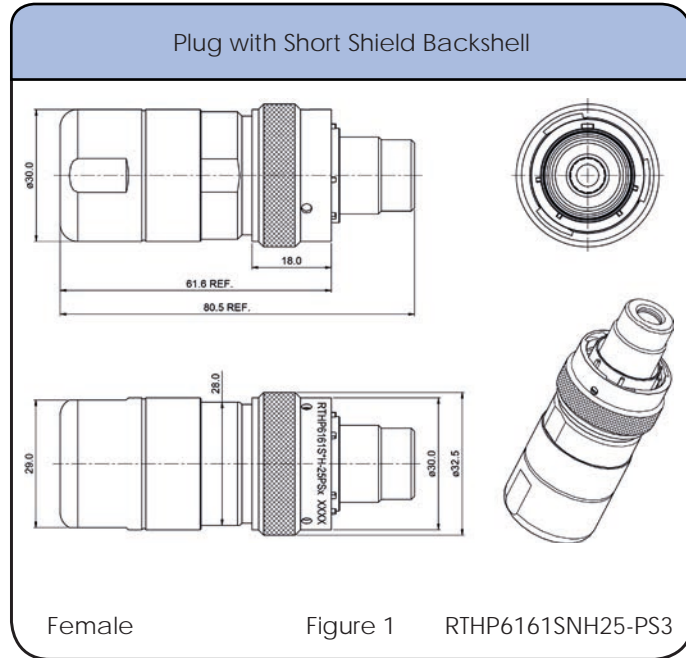

Shell Size: 16 Number of Contacts: 1 Contact Size: 8mm
Sealing: IP67 Salt Spray: 48h

Dimensions Square Flange Receptacle

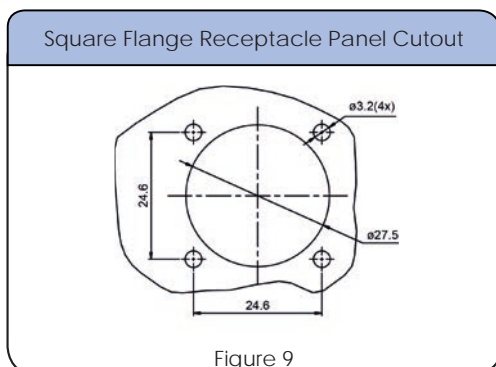
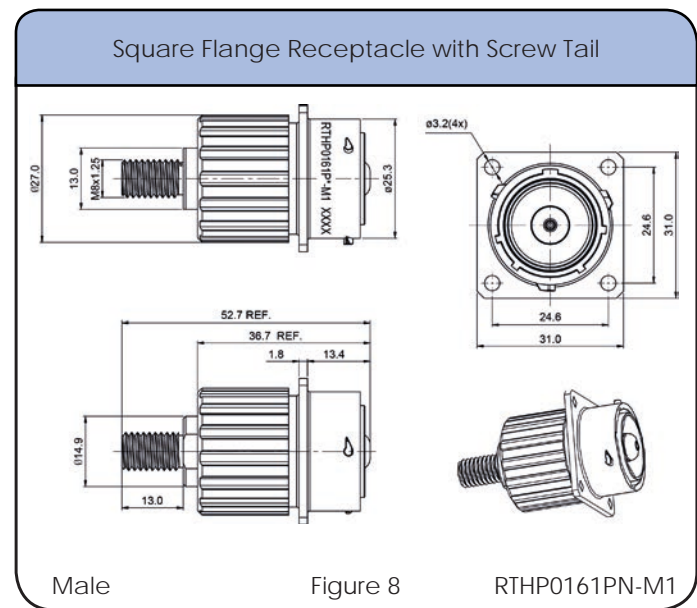
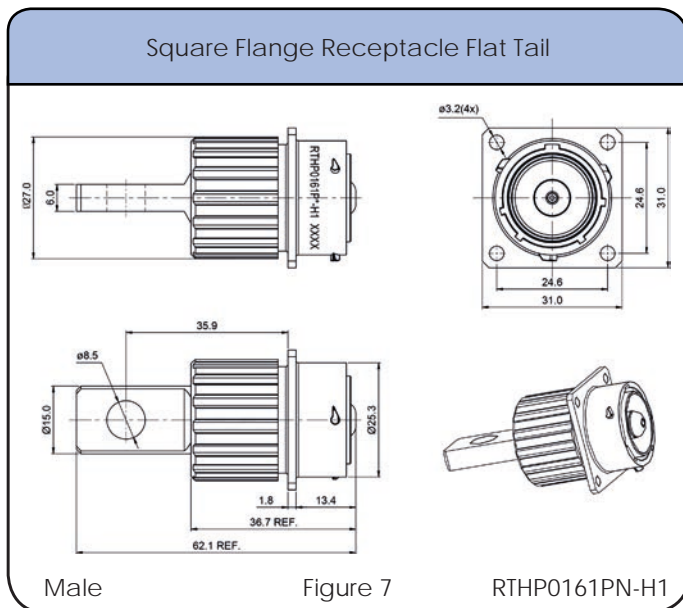
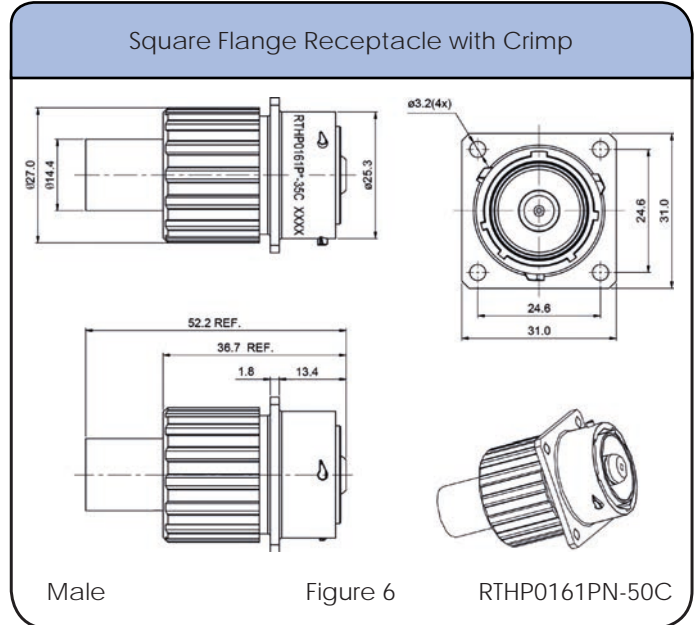
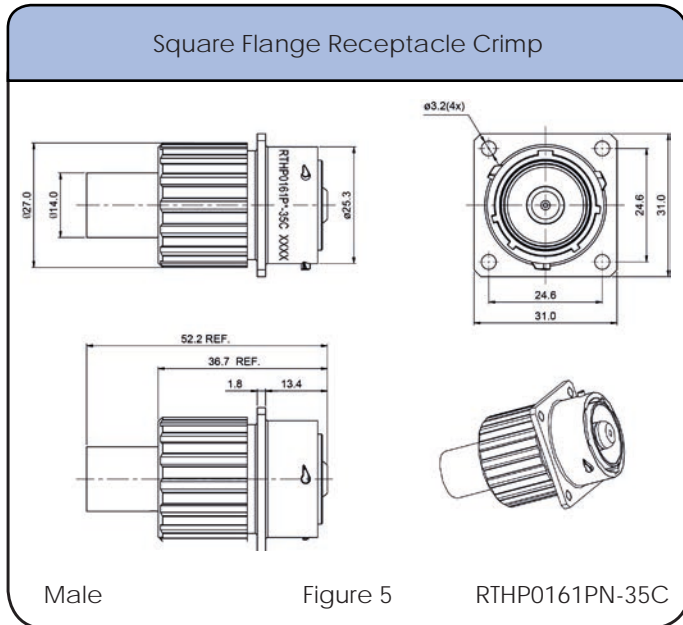

STEP 1
Choose Receptacle Style

STEP 2
Choose Plug Style

Square Flange
Receptacles



RTHP0201PN-50C



RTHP0201PN-70C



RTHP0201PN-95C



RTHP0201PN-H1



RTHP0201PN-M1

Plug



RTHP6201SNH25-PS5



RTHP6201SNH35-PS2



RTHP6201SNH50-PS2



RTHP6201SNH70-PS1



RTHP6201SNH70-PS2



RTHP6201SNH95-PS2



SEE TABLE ON NEXT PAGE FOR PART DETAILS

CONTACTS SOLD SEPARATELY SEE PAGE 191

Shell Size: 20 Number of Contacts: 1 Contact Size: 10mm
Sealing: IP67 Salt Spray: 48h

High Amperage eco | mate[®] rm with RADSOK[®] Technology

- Single Pole High Power Arrangements
- 10mm Contact Size
- Operating Temperature: -40°C to +125°C
- RoHS Compliant
- Operating Voltage: 630V
- Current Rating at 25°C: 300A
- Flammability Rating: UL94-V0
- High Reliability
- Low Contact Engagement / Separation Forces
- Low Contact Resistance
- High Mating Cycle Durability

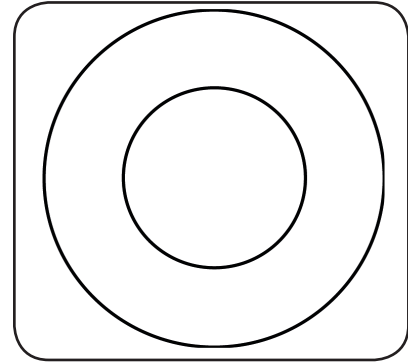

Insert Arrangement
Pin (Male) Faceview

Connector Part Numbers

Connector Part Number	Connector Type	Wire Range (mm ²)	Amps	Contact				Figure Drawings
				Part Number	Type	AWG	Plating	
RTHP6201SNH25-PS5	Female Plug with Short Shielded Backshell	20-25	120	HS25DCS	Crimp Barrel, Female	4	Silver	1
RTHP6201SNH35-PS2	Female Plug with Short Shielded Backshell	30-35	130	HS35DCS	Crimp Barrel, Female	4	Silver	2
RTHP6201SNH50-PS2	Female Plug with Short Shielded Backshell	40-50	180	HS50DCS	Crimp Barrel, Female	1/0-0	Silver	3
RTHP6201SNH70-PS1	Female Plug with Short Shielded Backshell	60-70	250	HS70DCS	Crimp Barrel, Female	2/0-0	Silver	4
RTHP6201SNH70-PS2	Female Plug with Short Shielded Backshell	60-70	250	HS70DCS	Crimp Barrel, Female	2/0-0	Silver	5
RTHP6201SNH95-PS2	Female Plug with Short Shielded Backshell	85-95	300	HS95DCS	Crimp Barrel, Female	3/0-0	Silver	6
RTHP0201PNH-50C	Male Square Flange Receptacle Crimp	40-50	180	HP50DCS	Crimp Barrel, Male	1/0-0	Silver	7,12
RTHP0201PNH-70C	Male Square Flange Receptacle with Crimp	60-70	250	HP70DCS	Crimp Barrel, Male	2/0-0	Silver	8,12
RTHP0201PNH-95C	Male Square Flange Receptacle with Crimp	85-95	300	HP95DCS	Crimp Barrel, Male	3/0-0	Silver	9,12
RTHP0201PNH-H1	Male Square Flange Receptacle with Flat Tail	N/A	300	HPDHS	Flathole Tail, Male	N/A	Silver	10,12
RTHP0201PNH-M1	Male Square Flange Receptacle with Screw Tail	N/A	300	HPDSS	Screw Tail, Male	N/A	Silver	11,12

Contacts included. See chart for specific requirements

Shell Size: 20
Sealing: IP67

Number of Contacts: 1
Salt Spray: 48h

Contact Size: 10mm

Dimensions Plug

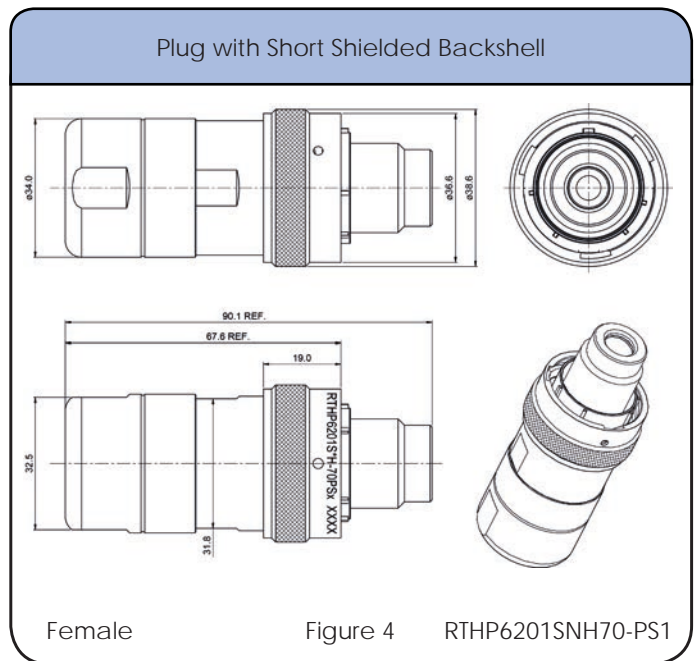
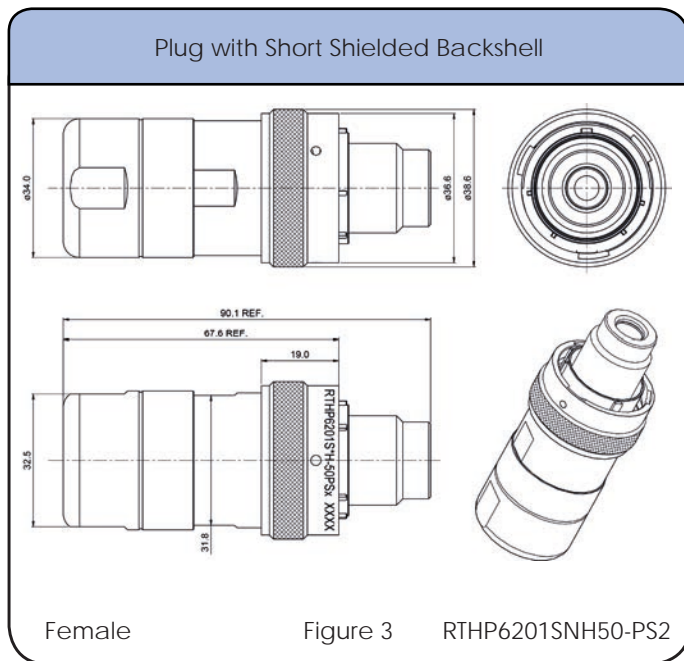
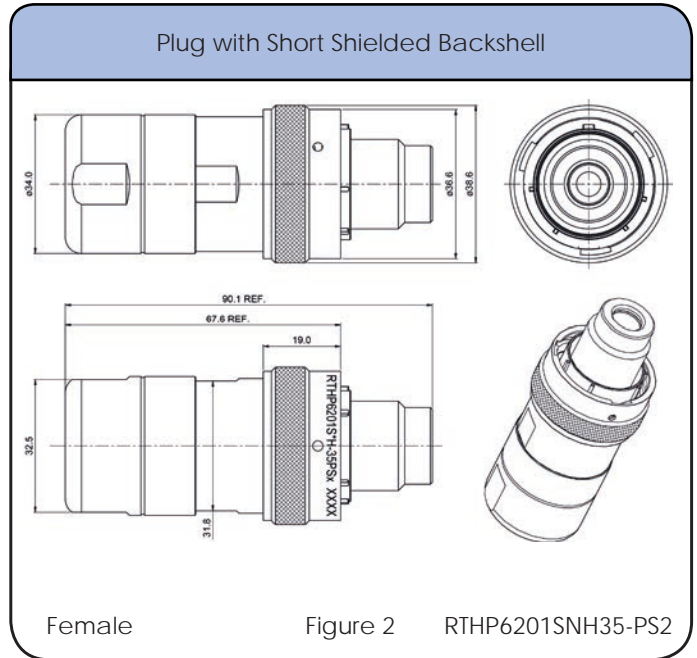
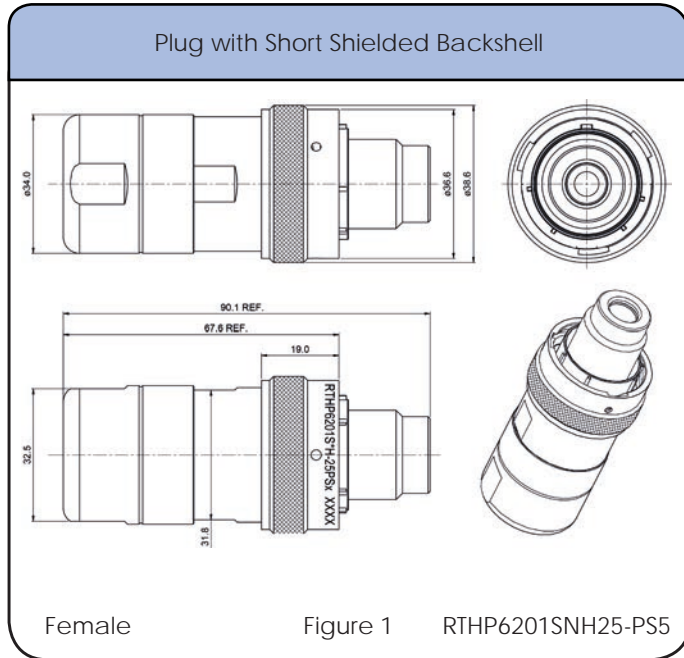

Shell Size: 20 Number of Contacts: 1
Sealing: IP67 Salt Spray: 48h

Contact Size: 10mm

Dimensions Plug (con't)

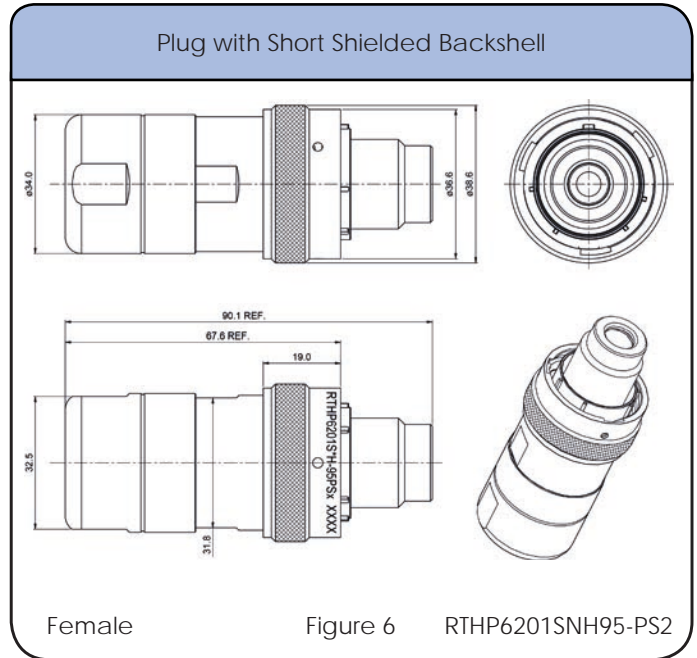
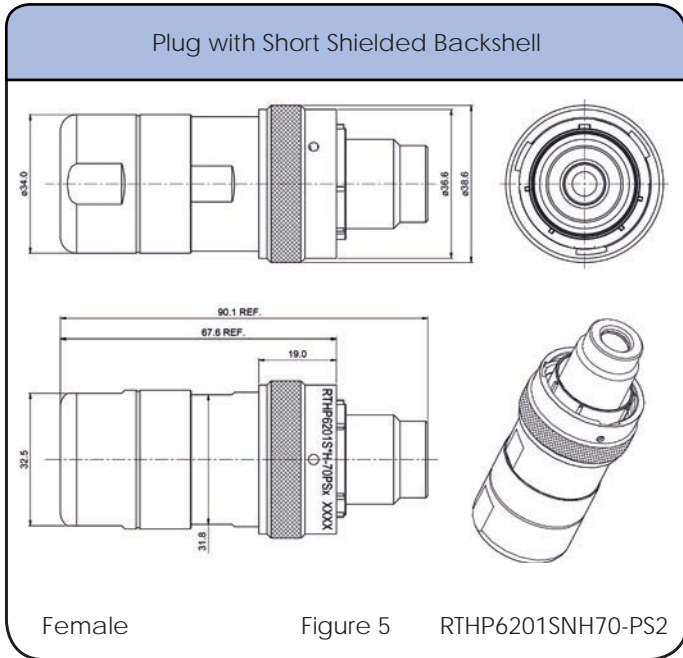

Shell Size: 20 Number of Contacts: 1 Contact Size: 10mm
 Sealing: IP67 Salt Spray: 48h

Dimensions Square Flange Receptacle

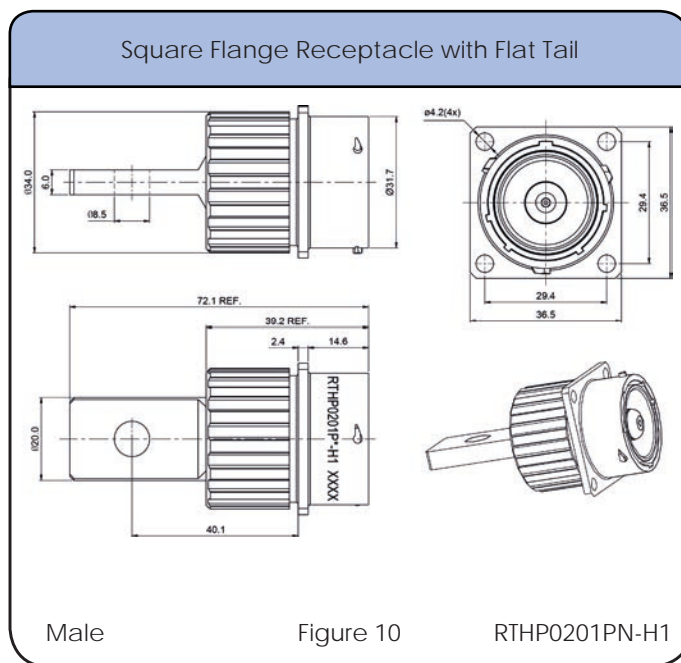
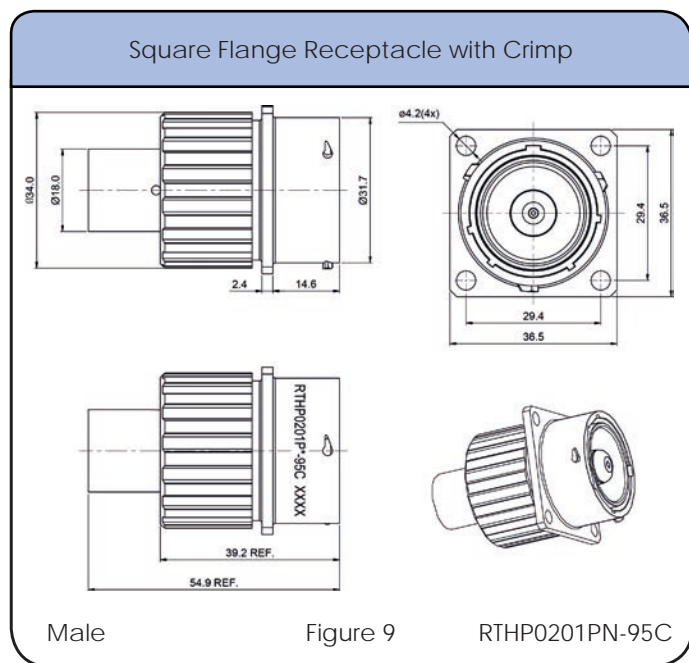
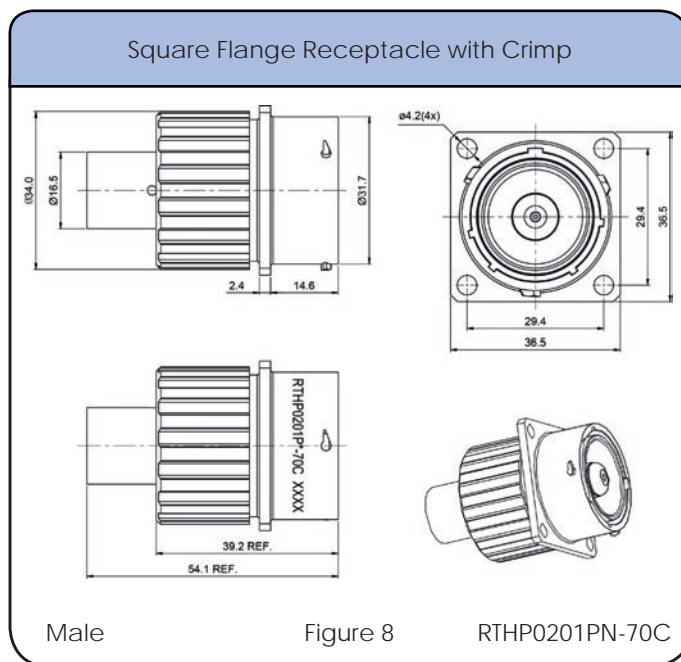
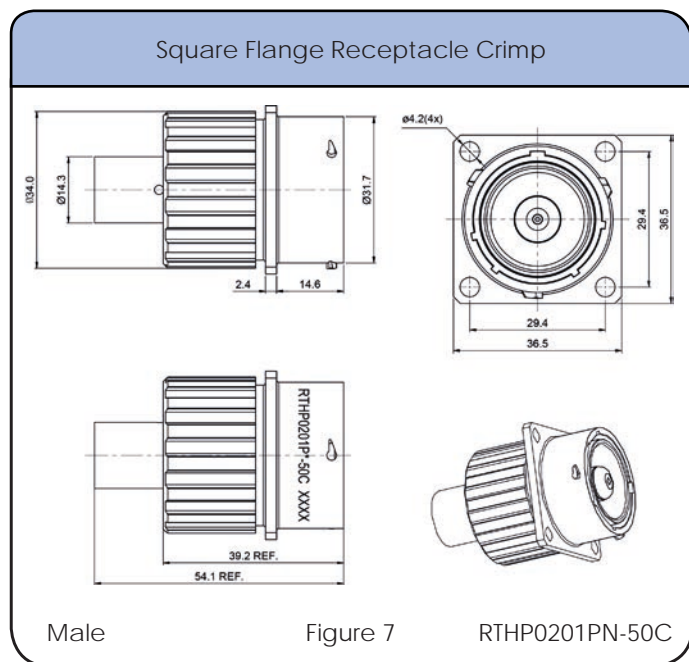

Shell Size: 20 Number of Contacts: 1 Contact Size: 10mm
Sealing: IP67 Salt Spray: 48h

Dimensions Square Flange Receptacle (con't)

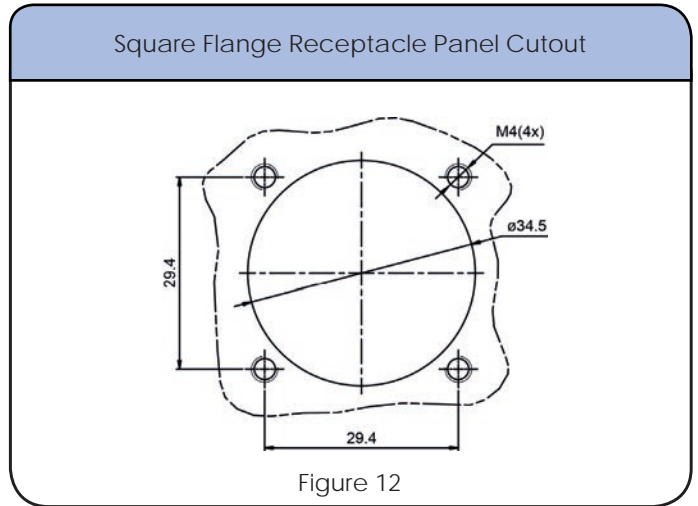
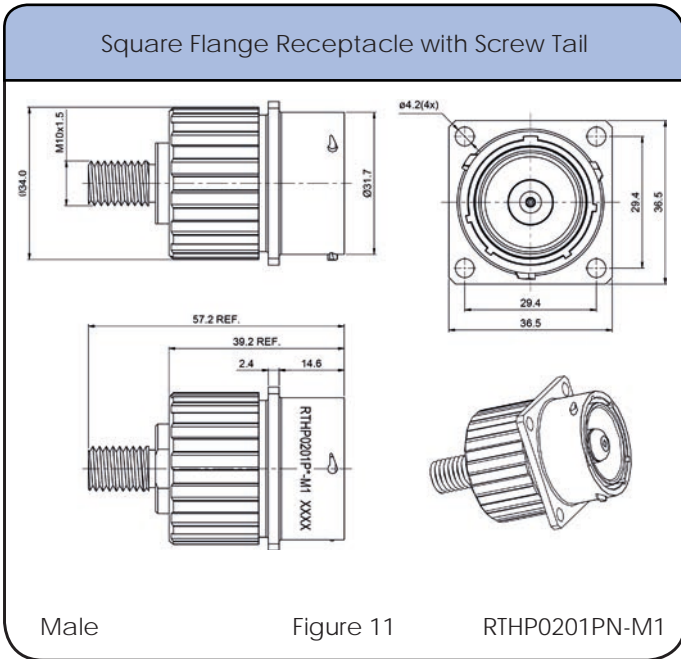

Contacts



STEP 1
Choose Receptacle Style

STEP 2
Choose Plug Style

Square Flange Receptacles



Plug



Crimp Barrel Contact



Flat Hole Tail Contact
(receptacle only)



Screw Tail Contact
(receptacle only)



SEE TABLE ON NEXT PAGE FOR PART DETAILS

CONTACTS INCLUDED SEE PAGE 197

Shell Size: 20 Number of Contacts: 3 Contact Size: 3.6 mm
Sealing: IP67 Salt Spray: 48h

High Amperage eco | mate[®] rm with RADSOK[®] Technology

- Single Pole High Power Arrangements
- 3.6mm Contact Size
- Operating Temperature: -40°C to +125°C
- RoHS Compliant
- Operating Voltage: 630V
- Current Rating at 25°C: 86A
- Flammability Rating: UL94-V0
- High Reliability
- Low Contact Engagement / Separation Forces
- Low Contact Resistance
- High Mating Cycle Durability

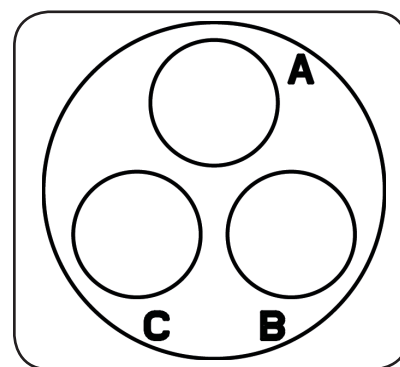

Insert Arrangement
Pin (Male) Faceview

Connector Part Number	Connector Type	Wire Range (mm ²)	Amps	Contact				Figure Drawings
				Part Number	Type	AWG	Plating	
RTHP6203PNH-16S2	Male 3 Position Plug with Shielded Backshell	10-16	86	MP6ARS8S	Crimp Barrel, Male	8	Silver	1
RTHP6203SNH-16S2	Female 3 Position Plug with Shielded Backshell	10-16	86	MS6ARS8S	Crimp Barrel, Female	8	Silver	2
RTHP0203PNH-16C	Male Square Flange Receptacle with Crimp	10-16	86	MP6ARS8S	Crimp Barrel, Male		Silver	3,5
RTHP0203SNH-16C	Female Square Flange Receptacle with Crimp	10-16	86	MS6ARS8S	Crimp Barrel, Female		Silver	4,5

Contacts included. See chart for specific requirements

Shell Size: 20
Sealing: IP67

Number of Contacts: 3
Salt Spray: 48h

Contact Size: 3.6 mm

Dimensions Plug

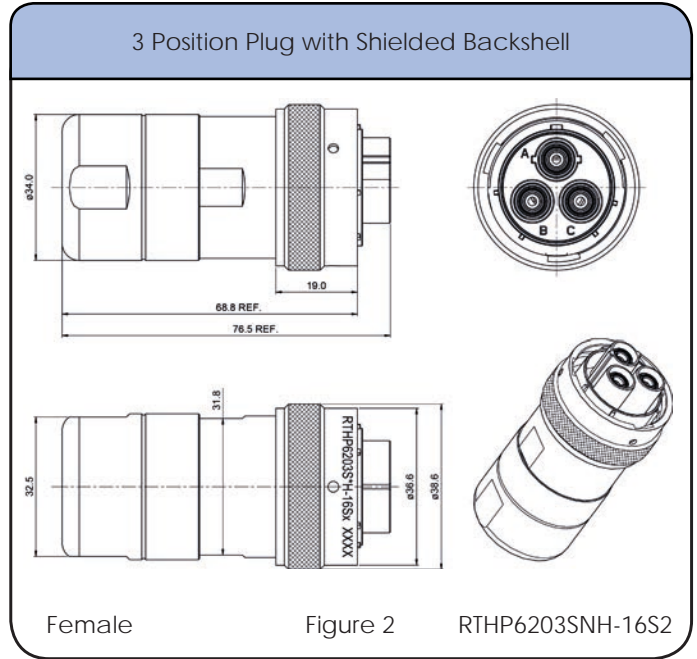
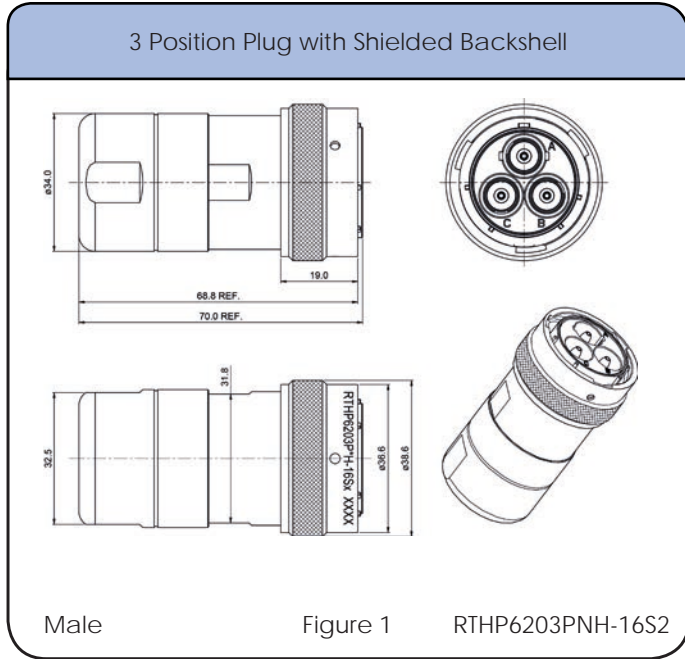

Shell Size: 20 Number of Contacts: 3 Contact Size: 3.6 mm
Sealing: IP67 Salt Spray: 48h

Dimensions Square Flange Receptacle

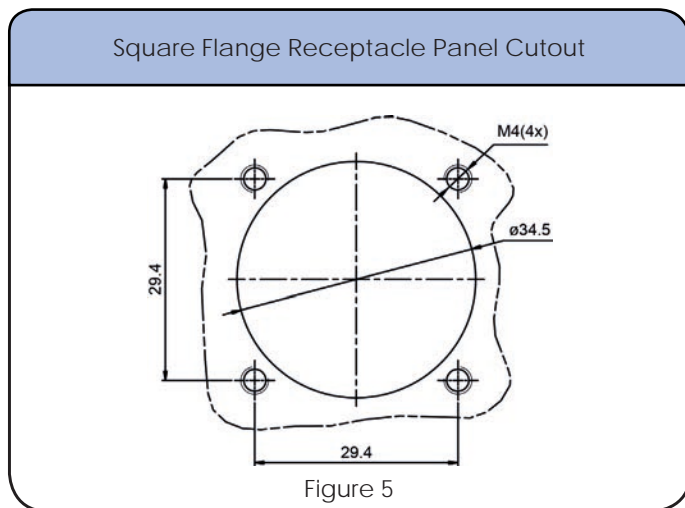
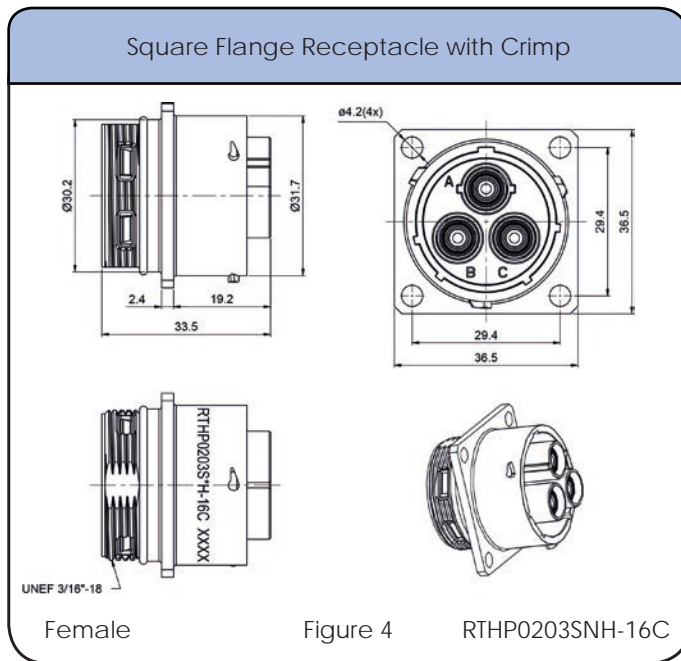
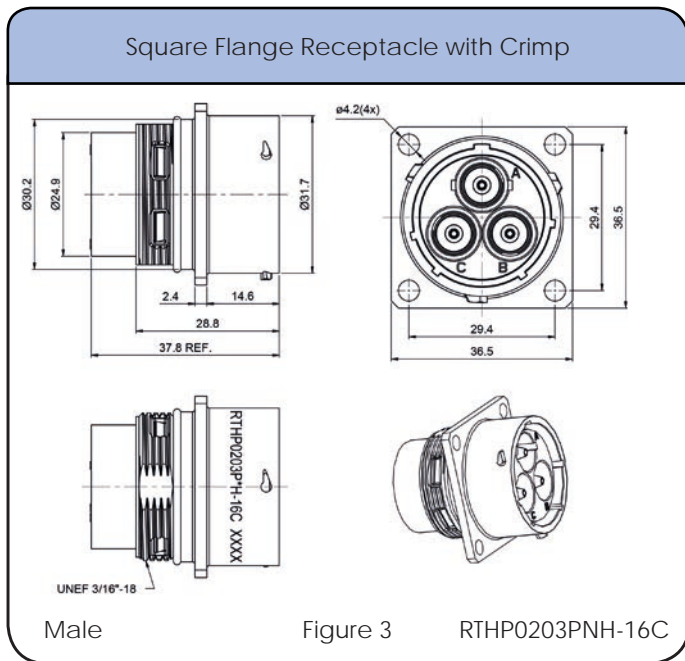

Contacts

Contact Overview

eco | mate[®] rm rugged metal shielded connectors and contacts are sold separately.

The contacts are offered in 2 types: machined and stamped & formed. The machined contacts are available in 3 styles: Standard, RADSOK[®], and PCB.

eco | mate[®] rm contacts are offered in multiple sizes and are designed to be used in any connector with the same active part size regardless of shell size. See our **Connector Guide** starting at page 6 for matching parts and contacts.

Our customers can then choose to buy only one type of contact to equip all of their connectors, even if the shell sizes vary. Our standardized connector solutions makes it easy for our customers to reduce their costs and simplify assembly.

The eco | mate[®] rm rugged metal shielded connectors and contacts are easy to install and remove.



Machined contacts are generally chosen as a better solution for power applications or when lower quantities are needed.



Stamped & Formed contacts are available automatically crimped, making them ideal for high volume production applications.

Technical information about crimped contacts on page 233

Contacts

Plating and Bulk Order Options

Plating Options

Symbol	Plating
T	Tin Plated (For Stamped and Formed Contacts)
S	Silver Plated 5 Um (For Machined Contacts)
F	Gold Plated
G5	Gold Plated (Thickness 5μ")
G10	Gold Plated (Thickness 10μ")
G15	Gold Plated (Thickness 15μ")
G30	Gold Plated (Thickness 30μ")

Contacts supplied separately

Standard Quantity Order Options

Stamped & Formed		Machined	
			
<ul style="list-style-type: none"> • 25 pieces • bulk package 	<ul style="list-style-type: none"> • 3000 pieces • reel 	<ul style="list-style-type: none"> • 25 pieces • bulk package 	<ul style="list-style-type: none"> • 1000 pieces • bulk package

Amphenol offers two types of electrical contacts:

Machined

Contacts

Stamped & Formed Crimped Contact Part Numbers



Contact Size	AWG	Wire range mm ²	Current (A)	Electrical Resistance	Insulation Diameter (mm)	Plating	PART NUMBER	
							Male	Female
2.5mm	14-12	2.5-3.5	23	--	4.3	Tin	SP12A1T	SS12A1T
16 (Ø1.6mm)	14	2.0-2.5	13	<6mΩ	3.2	Gold Flash	SP14M1F	SS14M1F
16 (Ø1.6mm)	14	2.0-2.5	13	<6mΩ	3.2	Gold 5μ"	SP14M1G5	SS14M1G5
16 (Ø1.6mm)	14	2.0-2.5	13	<6mΩ	3.2	Gold 10μ"	SP14M1G10	SS14M1G10
16 (Ø1.6mm)	14	2.0-2.5	13	<6mΩ	3.2	Gold 15μ"	SP14M1G15	SS14M1G15
16 (Ø1.6mm)	14	2.0-2.5	13	<6mΩ	3.2	Gold 30μ"	SP14M1G30	SS14M1G30
16 (Ø1.6mm)	18-16	.75-1.5	13	<6mΩ	3.2	Gold Flash	SP16M1F	SS16M1F
16 (Ø1.6mm)	18-16	.75-1.5	13	<6mΩ	3.2	Gold 5μ"	SP16M1G5	SS16M1G5
16 (Ø1.6mm)	18-16	.75-1.5	13	<6mΩ	3.2	Gold 10μ"	SP16M1G10	SS16M1G10
16 (Ø1.6mm)	18-16	.75-1.5	13	<6mΩ	3.2	Gold 15μ"	SP16M1G15	SS16M1G15
16 (Ø1.6mm)	18-16	.75-1.5	13	<6mΩ	3.2	Gold 30μ"	SP16M1G30	SS16M1G30
16 (Ø1.6mm)	22-20	.34-.50	13	<6mΩ	3.2	Gold Flash	SP20M1F	SS20M1F
16 (Ø1.6mm)	22-20	.34-.50	13	<6mΩ	3.2	Gold 5μ"	SP20M1G5	SS20M1G5
16 (Ø1.6mm)	22-20	.34-.50	13	<6mΩ	3.2	Gold 10μ"	SP20M1G10	SS20M1G10
16 (Ø1.6mm)	22-20	.34-.50	13	<6mΩ	3.2	Gold 15μ"	SP20M1G15	SS20M1G15
16 (Ø1.6mm)	22-20	.34-.50	13	<6mΩ	3.2	Gold 30μ"	SP20M1G30	SS20M1G30
16 (Ø1.6mm)	26-24	.14-.25	13	<6mΩ	3.2	Gold Flash	SP24M1F	SS24M1F
16 (Ø1.6mm)	26-24	.14-.25	13	<6mΩ	3.2	Gold 5μ"	SP24M1G5	SS24M1G5

Available in Packages of 25 pieces or the Standard Reel Size of 3,000 pieces

Contacts

Stamped & Formed Contact Part Numbers (con't)



Contact Size	AWG	Wire range mm ²	Current (A)	Electrical Resistance	Insulation Diameter (mm)	Plating	PART NUMBER	
							Male	Female
16 (Ø1.6mm)	26-24	.14-.25	13	<6mΩ	3.2	Gold 10μ"	SP24M1G10	SS24M1G10
16 (Ø1.6mm)	26-24	.14-.25	13	<6mΩ	3.2	Gold 15μ"	SP24M1G15	SS24M1G15
16 (Ø1.6mm)	26-24	.14-.25	13	<6mΩ	3.2	Gold 30μ"	SP24M1G30	SS24M1G30
20 (Ø1.mm)	22-20	.34-.50	5	<15mΩ	2.6	Gold Flash	SP20W1F	SS20W1F
20 (Ø1.mm)	22-20	.34-.50	5	<15mΩ	2.6	Gold 5μ"	SP20W1G5	SS20W1G5
20 (Ø1.mm)	22-20	.34-.50	5	<15mΩ	2.6	Gold 10μ"	SP20W1G10	SS20W1G10
20 (Ø1.mm)	22-20	.34-.50	5	<15mΩ	2.6	Gold 15μ"	SP20W1G15	SS20W1G15
20 (Ø1.mm)	22-20	.34-.50	5	<15mΩ	2.6	Gold 30μ"	SP20W1G30	SS20W1G30
20 (Ø1.mm)	26-24	.14-.25	5	<15mΩ	2.6	Gold Flash	SP24W1F	SS24W1F
20 (Ø1.mm)	26-24	.14-.25	5	<15mΩ	2.6	Gold 5μ"	SP24W1G5	SS24W1G5
20 (Ø1.mm)	26-24	.14-.25	5	<15mΩ	2.6	Gold 10μ"	SP24W1G10	SS24W1G10
20 (Ø1.mm)	26-24	.14-.25	5	<15mΩ	2.6	Gold 15μ"	SP24W1G15	SS24W1G15
20 (Ø1.mm)	26-24	.14-.25	5	<15mΩ	2.6	Gold 30μ"	SP24W1G30	SS24W1G30
20 (Ø1.mm)	30-28	.05-.08	5	<15mΩ	2.6	Gold Flash	SP28W1F	SS28W1F
20 (Ø1.mm)	30-28	.05-.08	5	<15mΩ	2.6	Gold 5μ"	SP28W1G5	SS28W1G5
20 (Ø1.mm)	30-28	.05-.08	5	<15mΩ	2.6	Gold 10μ"	SP28W1G10	SS28W1G10
20 (Ø1.mm)	30-28	.05-.08	5	<15mΩ	2.6	Gold 15μ"	SP28W1G15	SS28W1G15
20 (Ø1.mm)	30-28	.05-.08	5	<15mΩ	2.6	Gold 30μ"	SP28W1G30	SS28W1G30

Available in Packages of 25 pieces or the Standard Reel Size of 3,000 pieces

Contacts

PCB Contacts



PCB Machined Contact Part Numbers

Contact Size	Description	Plating	PART NUMBER	
			Male	Female
20	Short Version	Gold Flash	MP20W12E06F	MS20W12E06F
20	Short Version	Gold 5 μ "	MP20W12E06G5	MS20W12E06G5
20	Short Version	Gold 10 μ "	MP20W12E06G10	MS20W12E06G10
20	Short Version	Gold 15 μ "	MP20W12E06G15	MS20W12E06G15
20	Short Version	Gold 30 μ "	MP20W12E06G30	MS20W12E06G30
20	Long Version	Gold Flash	MP20W12E09F	MS20W12E09F
20	Long Version	Gold 5 μ "	MP20W12E09G5	MS20W12E09G5
20	Long Version	Gold 10 μ "	MP20W12E09G10	MS20W12E09G10
20	Long Version	Gold 15 μ "	MP20W12E09G15	MS20W12E09G15
20	Long Version	Gold 30 μ "	MP20W12E09G30	MS20W12E09G30
16	Short Version	Gold Flash	MP16M12E06F	MS16M12E06F
16	Short Version	Gold 5 μ "	MP16M12E06G5	MS16M12E06G5
16	Short Version	Gold 10 μ "	MP16M12E06G10	MS16M12E06G10
16	Short Version	Gold 15 μ "	MP16M12E06G15	MS16M12E06G15
16	Short Version	Gold 30 μ "	MP16M12E06G30	MS16M12E06G30
16	Long Version	Gold Flash	MP16M12E09F	MS16M12E09F

Contacts

PCB Machined Contact Part Numbers (con't)



Contact Size	Description	Plating	PART NUMBER	
			Male	Female
16	Long Version	Gold 5μ"	MP16M12E09G5	MS16M12E09G5
16	Long Version	Gold 10μ"	MP16M12E09G10	MS16M12E09G10
16	Long Version	Gold 15μ"	MP16M12E09G15	MS16M12E09G15
16	Long Version	Gold 30μ"	MP16M12E09G30	MS16M12E09G30
2.5 mm	Short Version	Gold Flash	MP10B12E05F	MS10B12E05F
2.5 mm	Short Version	Gold 5μ"	MP10B12E05G5	MS10B12E05G5
2.5 mm	Short Version	Gold 10μ"	MP10B12E05G10	MS10B12E05G10
2.5 mm	Short Version	Gold 15μ"	MP10B12E05G15	MS10B12E05G15
2.5 mm	Short Version	Gold 30μ"	MP10B12E05G30	MS10B12E05G30
2.5 mm	Long Version	Gold Flash	MP10B12E08F	MS10B12E08F
2.5 mm	Long Version	Gold 5μ"	MP10B12E08G5	MS10B12E08G5
2.5 mm	Long Version	Gold 10μ"	MP10B12E08G10	MS10B12E08G10
2.5 mm	Long Version	Gold 15μ"	MP10B12E08G15	MS10B12E08G15
2.5 mm	Long Version	Gold 30μ"	MP10B12E08G30	MS10B12E08G30

Available in Standard Package Sizes: 25 or 1,000 pieces

PCB Soldering

The PNPCF series can be used in a wave soldering process, but not in a reflow soldering process. All high temperature processes are prohibited.

Contacts

PCB Contacts Dimensions

Nominal Length G (mm)

Dimensions of dipsolder contacts out of connector
(contacts to be ordered separately)

All dimensions are in mm
xx=plating options

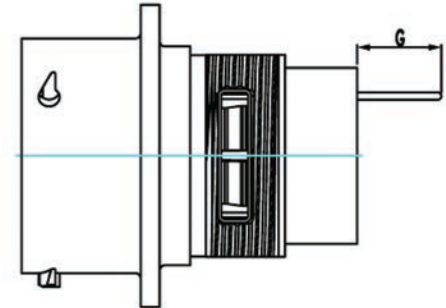

Shell Size	Pin Contact					
	MP20W12E06xx	MP20W12E09xx	MP16M12E04xx	MP16M12E06xx	MP10B12E05xx	MP10B12E08xx
10	4.0	9.5	4.0	8.0	--	--
12	4.0	9.5	4.0	8.0	5.0	--
14	4.0	9.5	4.0	8.0	5.2	--
16	4.0	9.5	4.0	8.0	--	--
18	--	9.5	4.0	8.0	--	--
20	--	9.5	4.0	8.0	--	--
24	--	--	--	3.9	--	--

Shell Size	Socket Contact					
	MS20W12E06xx	MS20W12E09xx	MS16M12E04xx	MS16M12E06xx	MS10B12E05xx	MS10B12E08xx
10	3.3	8.5	2.4	3.0	--	--
12	3.3	8.5	2.4	3.0	--	--
14	3.3	8.5	2.4	3.0	--	--
16	3.3	8.5	2.4	3.0	--	--
18	--	8.5	2.4	--	--	--
20	--	8.5	2.4	--	--	--
24	--	--	--	--	--	--

Contacts

Machined Standard Crimp Contact Part Numbers



Contact Size	AWG	Wire Range mm ²	Plating	Electrical Resistance	Part Number	
					Male	Female
8 (Ø3.6mm)	12-10	3.0-6.0	Silver	<5mΩ	MP10A23S	MS10A23S
16 (Ø1.6mm)	14	2.0-2.5	Gold Flash	<6mΩ	MP14M23F	MS14M23F
16 (Ø1.6mm)	14	2.0-2.5	Gold 5μ"	<6mΩ	MP14M23G5	MS14M23G5
16 (Ø1.6mm)	14	2.0-2.5	Gold 10μ"	<6mΩ	MP14M23G10	MS14M23G10
16 (Ø1.6mm)	14	2.0-2.5	Gold 15μ"	<6mΩ	MP14M23G15	MS14M23G15
16 (Ø1.6mm)	14	2.0-2.5	Gold 30μ"	<6mΩ	MP14M23G30	MS14M23G30
16 (Ø1.6mm)	18-16	.75-1.5	Gold Flash	<6mΩ	MP16M23F	MS16M23F
16 (Ø1.6mm)	18-16	.75-1.5	Gold 5μ"	<6mΩ	MP16M23G5	MS16M23G5
16 (Ø1.6mm)	18-16	.75-1.5	Gold 10μ"	<6mΩ	MP16M23G10	MS16M23G10
16 (Ø1.6mm)	18-16	.75-1.5	Gold 15μ"	<6mΩ	MP16M23G15	MS16M23G15
16 (Ø1.6mm)	18-16	.75-1.5	Gold 30μ"	<6mΩ	MP16M23G30	MS16M23G30
16 (Ø1.6mm)	22-20	.34-.50	Gold Flash	<6mΩ	MP20M23F	MS20M23F
16 (Ø1.6mm)	22-20	.34-.50	Gold 5μ"	<6mΩ	MP20M23G5	MS20M23G5
16 (Ø1.6mm)	22-20	.34-.50	Gold 10μ"	<6mΩ	MP20M23G10	MS20M23G10
16 (Ø1.6mm)	22-20	.34-.50	Gold 15μ"	<6mΩ	MP20M23G15	MS20M23G15
16 (Ø1.6mm)	22-20	.34-.50	Gold 30μ"	<6mΩ	MP20M23G30	MS20M23G30

continued on next page

Contacts

Machined Standard Crimp Contact Part Numbers(con't)



Contact Size	AWG	Wire Range mm ²	Plating	Electrical Resistance	Part Number	
					Male	Female
16 (Ø1.6mm)	26-24	.14-.25	Gold Flash	<6mΩ	MP24M23F	MS24M23F
16 (Ø1.6mm)	26-24	.14-.25	Gold 5μ"	<6mΩ	MP24M23G5	MS24M23G5
16 (Ø1.6mm)	26-24	.14-.25	Gold 10μ"	<6mΩ	MP24M23G10	MS24M23G10
16 (Ø1.6mm)	26-24	.14-.25	Gold 15μ"	<6mΩ	MP24M23G15	MS24M23G15
16 (Ø1.6mm)	26-24	.14-.25	Gold 30μ"	<6mΩ	MP24M23G30	MS24M23G30
20 (Ø1.mm)	22-20	.34-.50	Gold Flash	<15mΩ	MP20W23F	MS20W23F
20 (Ø1.mm)	22-20	.34-.50	Gold 5μ"	<15mΩ	MP20W23G5	MS20W23G5
20 (Ø1.mm)	22-20	.34-.50	Gold 10μ"	<15mΩ	MP20W23G10	MS20W23G10
20 (Ø1.mm)	22-20	.34-.50	Gold 15μ"	<15mΩ	MP20W23G15	MS20W23G15
20 (Ø1.mm)	22-20	.34-.50	Gold 30μ"	<15mΩ	MP20W23G30	MS20W23G30
20 (Ø1.mm)	26-24	.13-.25	Gold Flash	<15mΩ	MP24W23F	MS24W23F
20 (Ø1.mm)	26-24	.13-.25	Gold 5μ"	<15mΩ	MP24W23G5	MS24W23G5
20 (Ø1.mm)	26-24	.13-.25	Gold 10μ"	<15mΩ	MP24W23G10	MS24W23G10
20 (Ø1.mm)	26-24	.13-.25	Gold 15μ"	<15mΩ	MP24W23G15	MS24W23G15
20 (Ø1.mm)	26-24	.13-.25	Gold 30μ"	<15mΩ	MP24W23G30	MS24W23G30
20 (Ø1.mm)	30-28	.05-.08	Gold Flash	<15mΩ	MP28W23F	MS28W23F
20 (Ø1.mm)	30-28	.05-.08	Gold 5μ"	<15mΩ	MP28W23G5	MS28W23G5
20 (Ø1.mm)	30-28	.05-.08	Gold 10μ"	<15mΩ	MP28W23G10	MS28W23G10
20 (Ø1.mm)	30-28	.05-.08	Gold 15μ"	<15mΩ	MP28W23G15	MS28W23G15
20 (Ø1.mm)	30-28	.05-.08	Gold 30μ"	<15mΩ	MP28W23G30	MS28W23G30

Available in Standard Package Sizes: 25 or 1,000 pieces

Contacts

RADSOK® Contacts

RADSOK® Benefits at a Glance



- Cost effective production using stamp & form technology
- Fully automated production for full press capability
- Low insertion and extraction forces
- High number of mating cycles
- Reduced assembly effort
- Contact coverage up to 65%
- Long lasting contact normal forces guaranteed through optimal grid technology
- Self cleaning effect during the mating process
- No torque resistance required of electrical housing - allowing for easier designs
- Absorption of vibrations

RADSOK® Technical Data

High Reliability

Unique RADSOK® design and construction technology creates an electrical contact interface that exceeds typical interconnect requirements. Applications in Aerospace, Medical, Industrial, Automotive, Mining, Offshore and other harsh environments depend on the high reliability of Amphenol RADSOK® technology.

Low Contact Engagement/Separation Forces

The hyperbolic lamella socket contact construction distributes normal forces over a high percentage of the mating surface. This creates a smooth, even engagement effort. This force distribution also contributes to excellent performance in vibration applications with resistance to typical fretting corrosion.

Low Contact Resistance

The large interface between the socket lamella and pin surface result in very low contact resistance, enabling the RADSOK® contacts high current ratings compared to traditional power contact designs.

High Mating Cycle Durability

RADSOK® contacts with typical silver plating finishes have demonstrated survival of 10,000 mating cycles. Even with continuous exposure to harsh environmental abuse (salt, sand and high humidity), RADSOK® contacts have been tested to maintain low contact resistance beyond 10,000 mating cycles.

For more technical information about RADSOK® see page 226

Crimp Barrel Contact



Flat Hole Tail Contact



Screw Tail Contact



Contacts

RADSOK® Machined Contact Part Numbers

Contact Size	Description	Wire Range AWG	Wire range mm ²	Plating	Electrical Resistance	PART NUMBER	
						Male	Female
3.6mm	Crimp Barrel	8	10-16	Silver	<1.0mΩ	MP6ARS8S	MS6ARS8S
3.6mm	Crimp Barrel	8	8-10	Silver	<1.0mΩ	HP10ACS	HS10ACS
3.6mm	Screw Tail	N/A	N/A	Silver	<1.0mΩ	HPASS	HSASS
3.6mm	Flathole Tail	N/A	N/A	Silver	<1.0mΩ	HPAHS	HSAHS
6mm	Crimp Barrel	4	20-25	Silver	<1.0mΩ	HP25BCS	HS25BCS
6mm	Screw Tail	N/A	N/A	Silver	<1.0mΩ	HPBSS	HSBSS
6mm	Flathole Tail	N/A	N/A	Silver	<1.0mΩ	HPBHS	HSBHS
8mm	Crimp Barrel	4	20-25	Silver	<1.0mΩ	--	HS25CCS
8mm	Crimp Barrel	2	30-35	Silver	<1.0mΩ	HP35CCS	HS35CCS
8mm	Crimp Barrel	2	30-35	Silver	<1.0mΩ	HP50CCS	HS50CCS
8mm	Screw Tail	N/A	N/A	Silver	<1.0mΩ	HPCSS	HSCSS
8mm	Flathole Tail	N/A	N/A	Silver	<1.0mΩ	HPCHS	HSCHS
10mm	Crimp Barrel	4	20-25	Silver	<1.0mΩ	--	HS25DCS
10mm	Crimp Barrel	2	30-35	Silver	<1.0mΩ	--	HS35DCS
10mm	Crimp Barrel	1/0-1	40-50	Silver	<1.0mΩ	HP50DCS	HS50DCS
10mm	Crimp Barrel	2/0-1	60-70	Silver	<1.0mΩ	HP70DCS	HS70DCS
10mm	Crimp Barrel	3/0-1	85-95	Silver	<1.0mΩ	HP95DCS	HS95DCS
10mm	Screw Tail	N/A	N/A	Silver	<1.0mΩ	HPDSS	HSDSS
10mm	Flathole Tail	N/A	N/A	Silver	<1.0mΩ	HPDHS	HSDHS

Available in Standard Package Size: 25 or 1,000 pieces

Field of Application Amperage for RADSOK® Machined Contacts



RTHP / RADSOK® Connectors
starting at page 181

	Contact Size	25° C
Amperage	3.6mm	86 A
	6mm	120A
	8mm	180 A
	10mm	300 A

All technical data has been measured in a laboratory environment and can be different during practical usage of the product. Any product information is for descriptive usage only and not legally binding. In particular, the information does not constitute or provide any legal guarantees.

eco|mate[®] rm

Rugged Metal Shielded Connectors

Technical Information

Tooling

Machined	212
Stamped & Formed	212
Contact Extraction Tool	212
Contact Extraction Tool Table	213
Contact Extraction Tool Instruction	214

Assembly Instructions

Jam Nut Assembly and Installation Instructions	215
Flange Assembly and Installation Instructions	216
eco mate [®] rm Standard Product Straight Plug and Receptacle Cable Assembly	217
eco mate [®] rm Standard Product Straight Plug and Receptacle with End Cap	219
eco mate [®] rm Standard Product Right Angle Plug and Receptacle Cable Assembly	220
eco mate [®] rm High Amperage Straight Plug Cable Assembly	222
eco mate [®] rm High Amperage Straight Plug - Shell Size 12 Cable Assembly	223
eco mate [®] rm High Amperage 90° Plug Cable Assembly	224

Technical Data

RADSOK [®] Product Overview	226
RADSOK [®] Advantages and Custom Developed Solutions	227
RADSOK [®] Series Rated Current and Working Voltage	228
RADSOK [®] Series Dynamic Overload Tests at Different Temperatures	229
eco mate [®] rm Standard Product Rated Current and Working Voltage	230
UL94 + UL1977 Industry Standards	231
IP Codes	232
Crimp Connection	233
Composition and Dimensions of Copper Wires	234
Reduction Values	235
Voltage Grading of Connectors	236
Creepage Distance	237

Tooling

Machined



Stamped & Formed

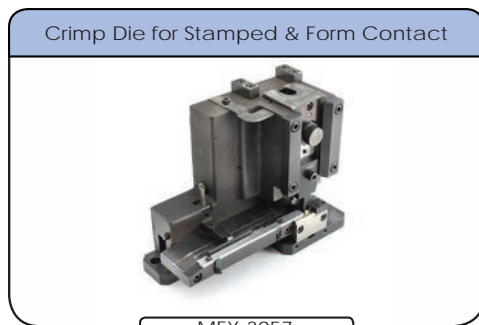

Contact Extraction Tool



Part Number	Description
QRT08R	3.6 mm contacts
QXRT08	3.6 mm contacts (eco mate [®] rm High Amperage)
QXRT125	2.5 mm contacts
QXRT16	#16 contacts
QXRT20	#20 contacts

Tooling

Contact Extraction Tool Table

Contact Size	Contact Part Number		Extraction Tool
	Male	Female	
2.5 mm	SP12A1T	SS12A1T	QXRT125
3.6mm	HP10ACS	HS10ACS	QRT0BR
	HP10AHS	HS10AHS	
	HP10ASS	HS10ASS	
6 mm	HP25BCS	HS25BCS	N/A
	HP25BHS	HS25BHS	
	HP25BSS	HS25BSS	
8 mm	HP35CSS	HS35CSS	N/A
	HP35CCS	HS35CCS	
	HP35CHS	HS35CHS	
10 mm	HP50DCS	HS50DCS	N/A
	HP50DHS	HS50DHS	
	HP50DSS	HS50DSS	
8	MP10A23S	MS10A23S	N/A

Contact Size 16	
Extraction Tool QXRT16	
Contact Part Number	
Male	Female
MP14M23F	MS14M23F
SP14M1F	SS14M1F
MP14M23FG5	MS14M23G5
SP14M1G5	SS14M1G5
SP14M1G10	SS14M1G10
MP14M23FG10	MS14M23G10
SP14M1G15	SS14M1G15
MP14M23FG15	MS14M23G15
MP14M23G30	MS14M23G30
SP14M1G30	SS14M1G30
MP16M23F	MS16M23F
SP16M1F	SS16M1F
MP16M23G5	MS16M23G5
SP16M1G5	SS16M1G5
SP16M1G10	SS16M1G10
MP16M23G10	MS16M23G10
SP16M1G15	SS16M1G15
MP16M23G15	MS16M23G15
SP16M1G30	SS16M1G30
MP16M23G30	MS16M23G30

Contact Size 16 (con't)	
Extraction Tool QXRT16	
Contact Part Number	
Male	Female
SP20M1F	SS20M1F
MP20M23F	MS20M23F
SP20M1G5	SS20M1G5
MP20M23G5	MS20M23G5
SP20M1G10	SS20M1G10
MP20M23G10	MS20M23G10
SP20M1G15	SS20M1G15
MP20M23G15	MS20M23G15
SP20M1G30	SS20M1G30
MP20M23G30	MS20M23G30
SP24M1F	SS24M1F
MP24M23F	MS24M23F
SP24M1G5	SS24M1G5
MP24M23G5	MS24M23G5
MP24M23G10	MS24M23G10
SP24M1G10	SS24M1G10
MP24M23G15	MS24M23G15
SP24M1G15	SS24M1G15
MP24M23G30	MS24M23G30
SP24M1G30	SS24M1G30

Contact Size 20	
Extraction Tool QXRT20	
Contact Part Number	
Male	Female
MP20W23F	MS20W23F
SP20W1F	SS20W1F
SP20W1G5	SS20W1G5
MP20W23G5	MS20W23G5
SP20W1G10	SS20W1G10
MP20W23G10	MS20W23G10
MP20W23G15	MS20W23G15
SP20W1G15	SS20W1G15
MP20W23G30	MS20W23G30
SP20W1G30	SS20W1G30
MP24W23F	MS24W23F
SP24W1F	SS24W1F
SP24W1G5	SS24W1G5
MP24W23G5	MS24W23G5
SP24W1G10	SS24W1G10
MP24W23G10	MS24W23G10
MP24W23G15	MS24W23G15
SP24W1G15	SS24W1G15
MP24W23G30	MS24W23G30
MP28W23F	MS28W23F
SP28W1F	SS28W1F
SP28W1G5	SS28W1G5
MP28W23G5	MS28W23G5
SP28W1G10	SS28W1G10
MP28W23G10	MS28W23G10
MP28W23G15	MS28W23G15
SP28W1G15	SS28W1G15
SP28W1G30	SS28W1G30
MP28W23G30	MS28W23G30

Tooling

Contact Extraction Tool Instruction

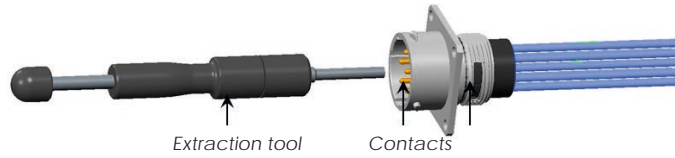

Step 1 Put extraction tool into insert



Step 2 Push the handle to take out the contacts



Step 3



Connector

Step 4



Assembly Instructions

Jam Nut Assembly and Installation Instructions

1. Remove insulation from wires and terminate contacts
2. Push contacts into connector insert
3. Seat o-ring, install and fasten receptacle in the panel cut-out
4. Tighten jam nut

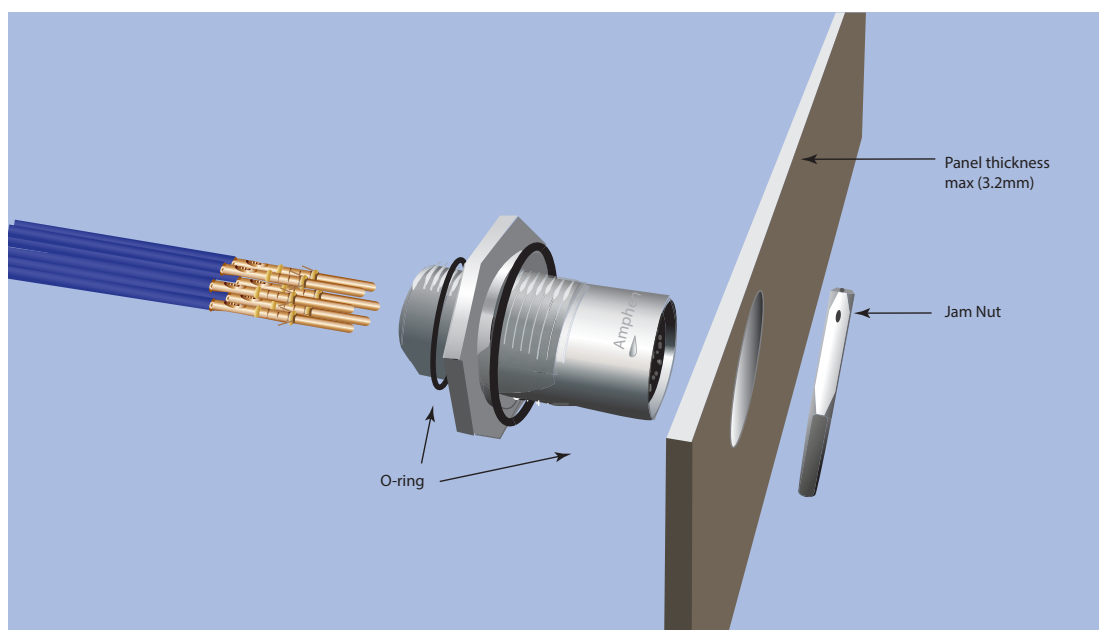

Shell Size	Jam Nut torque (Nm)	Exterior jam nut dim. (min)	Ø Wire max (mm)	Panel thickness max (mm)
10	3.4-4.1	22.2	3.2	3.2
12	5.2-5.6	27.0	3.2	3.2
14	6.2-6.8	32.0	3.2	3.2
16	7.9-8.5	33.3	3.2	3.2
18	9.0-9.6	36.5	3.2	3.2
20	10.2-10.7	39.7	3.2	3.2
22	11.3-12.4	42.9	3.2	3.2
24	12.4-13.6	46.0	3.2	3.2

Assembly Instructions

Flange Assembly and Installation Instructions

Front Assembly

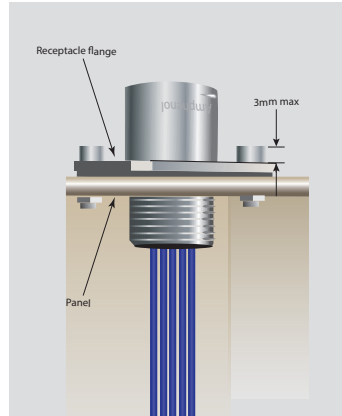
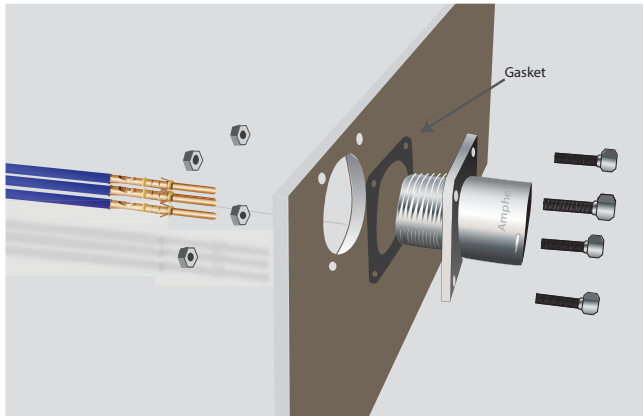

Rear Assembly

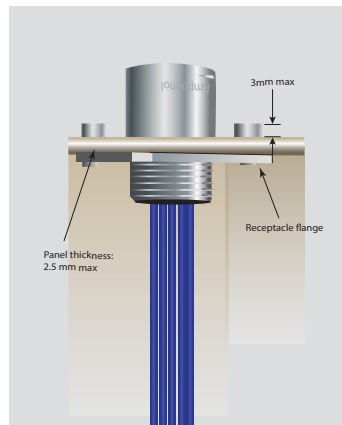
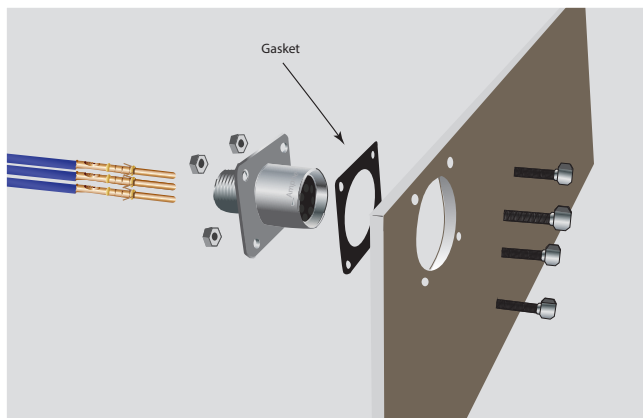

Shell Size	Screw tightening torque (Nm)
10	0.30/0.40
12	0.30/0.40
14	0.30/0.40
16	0.30/0.40
18	0.35/0.45
20	0.50/0.60
22	0.55/0.65
24	0.55/0.65

1. Remove insulation from wires and terminate contacts
2. Push contacts into connector insert
3. Install and fasten receptacle in the panel cutout
4. For increased sealing of the system, use optional gasket

Assembly Instructions

eco | mate[®] rm Straight Plug and Receptacle Cable Assembly



Step 1: Slide parts onto cable



Shell Size	L1 (long back shell)	L1 (short back shell)
10	25-30 mm	20-25 mm
12	30-35 mm	25-30 mm
14	30-35 mm	25-30 mm
16	35-40 mm	30-35 mm
18	35-40 mm	30-35 mm

Step 2: Strip jacket



* Make sure exposed shielding is not nicked or cut

Step 3: Attach tie-wrap



Dimensions are for reference only

Contact Size	L2 (stamped)	L2 (machined)
8#	NA	7.5-8.5 mm
12#	8.2-9.2 mm	8.5-9.5 mm
16#	5.0-5.5 mm	7.5-8.5 mm
20#	5.5-6.0 mm	7.0-8.0 mm

Step 4: Trim tie-wrap



Step 5: Trim braided shield flush to edge of tie-wrap



Step 6: Strip to conductor



Step 7: Attach contacts to wire leads

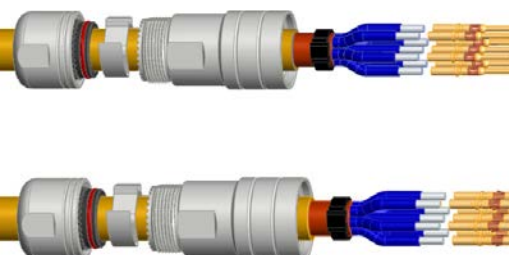

Step 8: Crimp contacts

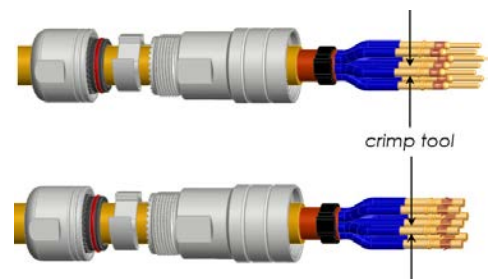

Assembly Instructions

eco | mate[®] rm Straight Plug and Receptacle Cable Assembly (con't)

Step 9: Insert contacts into connector cavities

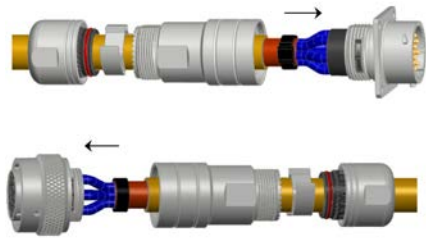

Step 10: Assemble back shell

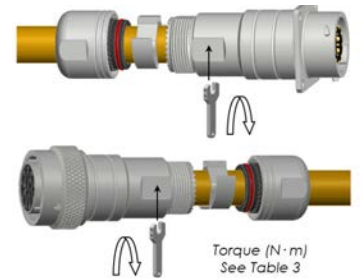

Step 11: Push shielding clip into backshell



Step 12: Push cable grommet into backshell



Step 13: Tighten metal nut



Step 14 Mate receptacle & plug (align the master key)



Size	Torque=T1 (N.m)
10	1.5~2.5 N.m
12	2.5~4.0 N.m
14	2.5~4.0 N.m
16	3.0~4.5 N.m
18	3.0~4.5N.m

Size	Torque=T2 (N.m)
10	2.0~3.0 N.m
12	3.0~5.0 N.m
14	3.5~5.5 N.m
16	4.0~6.0 N.m
18	5.0~8.0 N.m

Assembled Dimensions

Shell Size	Plug with socket match with long cord grip	Plug with socket match with short cord grip	Plug with pin match with long cord grip	Plug with pin match and short cord grip
10	43.0mm	33.0mm	38.0mm	28.0mm
12	45.0mm	35.0mm	35.0mm	25.0mm
14	45.0mm	35.0mm	35.0mm	25.0mm
16	45.0mm	35.0mm	40.0mm	30.0mm
18	48.0mm	39.0mm	40.0mm	32.0mm

Assembly Instructions

eco | mate[®] rm Straight Plug and Receptacle with End Cap

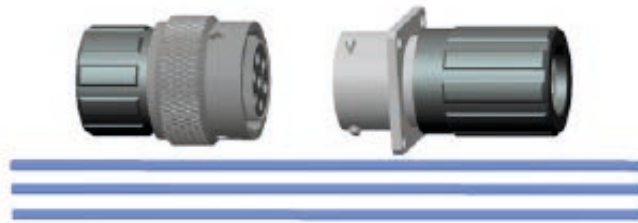

Step 1: Strip insulator

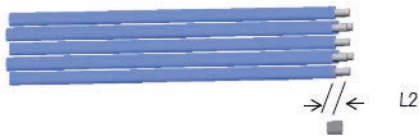
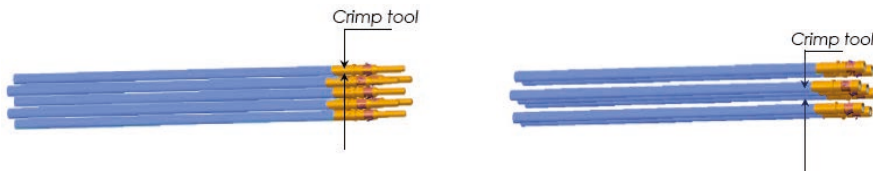

Table 2		
Contact Size	L2 (stamped)	L2 (machined)
8#	NA	7.5-8.5 mm
12#	8.2-9.2 mm	8.5-9.5 mm
16#	5.0-5.5 mm	7.5-8.5 mm
20#	5.5-6.0 mm	7.0-8.0 mm

Step 2: Attach contacts to wire leads



Step 3: Crimp contacts



Step 4: Insert contacts into connector cavities

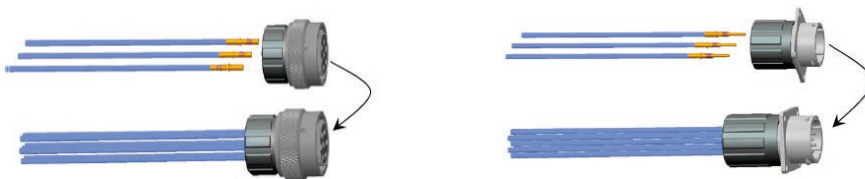

Step 5: Mate plug and receptacle (align the master key)



Assembly Instructions

eco | mate[®] rm Right Angle Plug and Receptacle Cable Assembly



Step 1: Slide parts onto cable

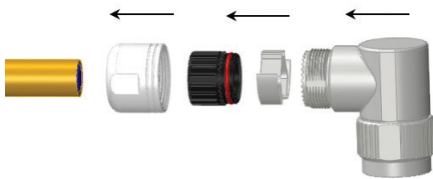
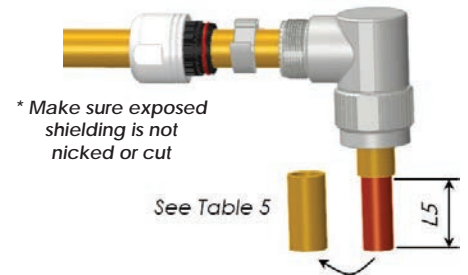

Table 5	
Size	L5 (90° cord grip)
10	NA
12	60-65 mm
14	60-65 mm
16	65-70 mm
18	NA

Dimensions are for reference only

Step 2: Strip jacket



Step 3: Attach tie-wrap

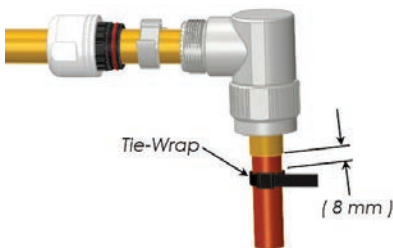
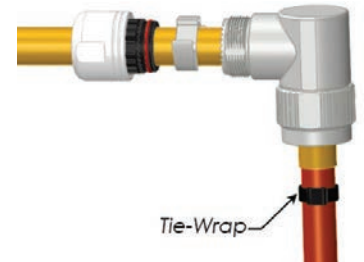

Table 2		
Contact Size	L2 (stamped)	L2 (machined)
8#	NA	7.5-8.5 mm
12#	8.2-9.2 mm	8.5-9.5 mm
16#	5.0-5.5 mm	7.5-8.5 mm
20#	5.5-6.0 mm	7.0-8.0 mm

Step 4: Trim tie-wrap



Step 5: Trim braided shield flush to edge of tie-wrap



Step 6: Strip to conductor

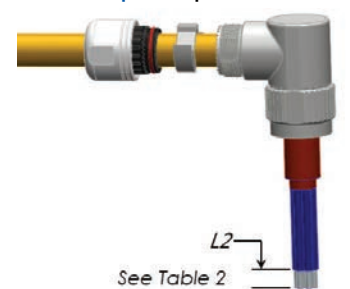

Step 7: Attach contacts to wire leads



Step 8: Crimp contacts

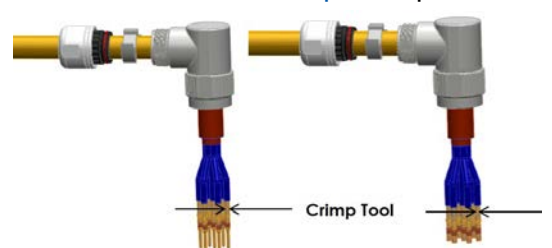

Assembly Instructions

eco | mate[®] rm Right Angle Plug and Receptacle Cable Assembly (cont.)

Step 9: Insert contacts into connector cavities

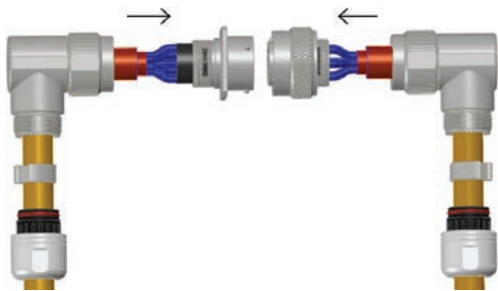

Step 10: Assemble back shell

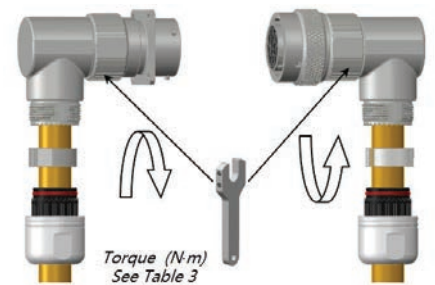

Step 11: Push shielding clip into backshell



Step 12 Push cable grommet into backshell

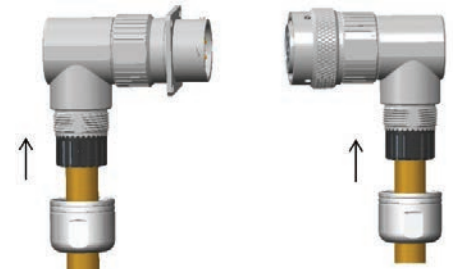
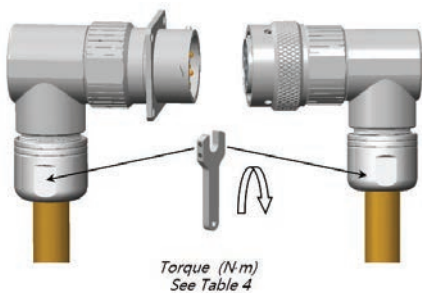
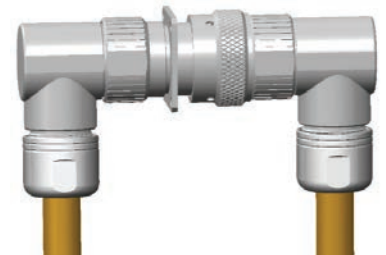

Table 4	
Size	Torque= T2 (N.m)
10	2.0-3.0 N.m
12	3.0-5.0 N.m
14	3.5-5.5 N.m
16	4.0-6.0 N.m
18	5.0-8.0 N.m

Step 13: Tighten metal nut



Step 14: Male receptacle & plug (align the master key)



Assembly Instructions

eco | mate[®] rm High Amperage Straight Plug Cable Assembly

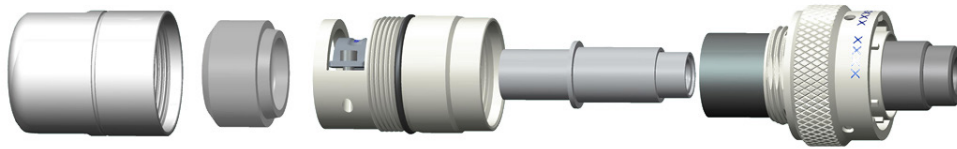

Step 1: Slide components onto cable

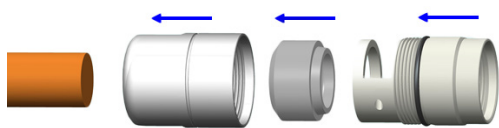

Step 2: Strip jacket

* Make sure exposed shielding is not nicked or cut

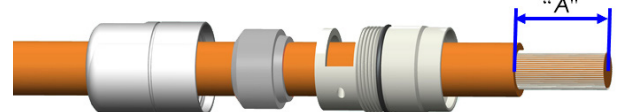

Step 3: Fold braided shielding over jacket

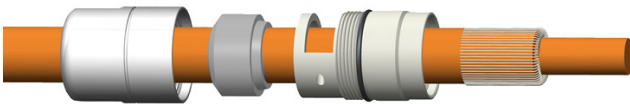

Step 4: Wrap foil over braided shielding



Step 5: Strip to conductor

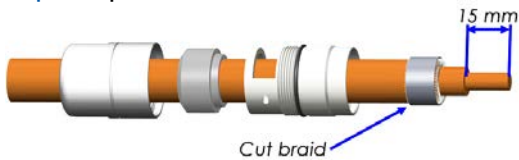

Step 6: Slide onto conductor and crimp



Step 7: Slide plug onto barrel

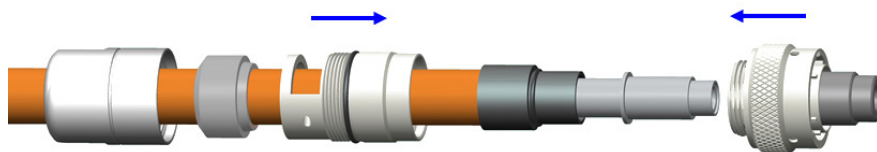

Step 8: Attach and tighten plug as shown

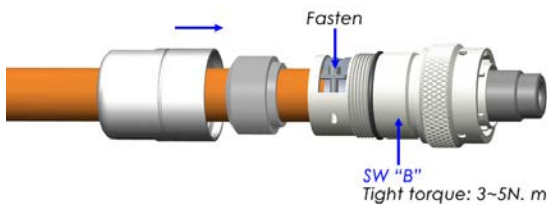

Step 9: Attach and tighten backshell as shown



Data Chart

Instruction	Shell 14	Shell 16	Shell 20
Dimension "A"	25 mm	25 mm	30 mm
SW "B"	24 mm	28 mm	32 mm
SW "C"	24.5 mm	29 mm	32.5 mm

Assembly Instructions

RTHP SERIES™ Straight Plug - Shell Size 12 Cable Assembly



Step 1: Slide parts onto cable

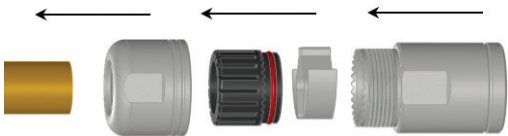

Step 2: Strip jacket to braided shielding and attach tie wrap

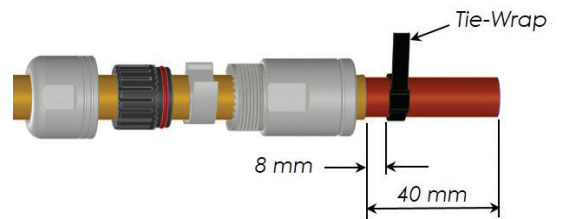

Step 3: Cut tie wrap to remove excessive material. Trim shielding flush to edge of tie wrap

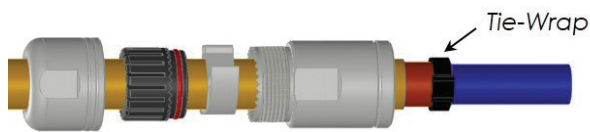

Step 4: Strip to conductor

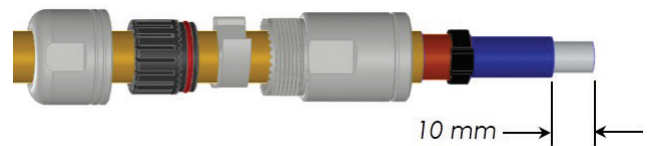

Step 5: Crimp terminal to conductor

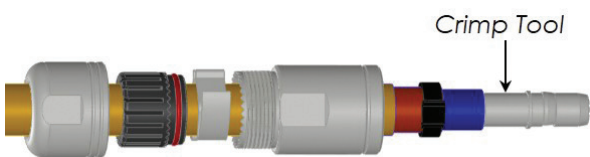

Step 6: Slide plug onto crimped terminal assembly

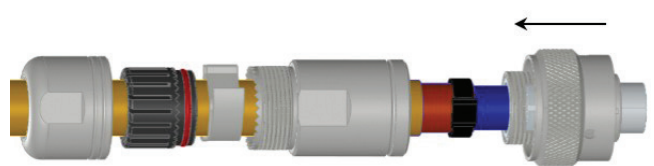

Step 7: Tighten plug to backshell. Perform pull test to assure correct contact assembly

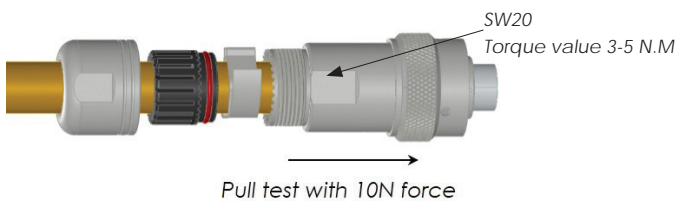

Step 8: Insert shielding clip and cable grommet. Attach and tighten back-nut to backshell

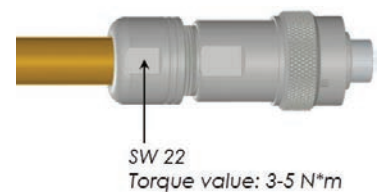

Assembly Instructions

eco | mate[®] rm High Amperage 90° Plug Cable Assembly

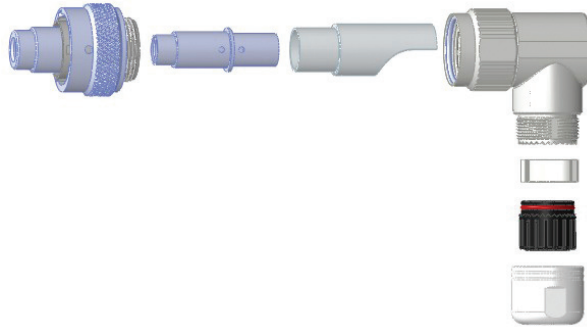

Step 1: Strip jacket to metal braiding

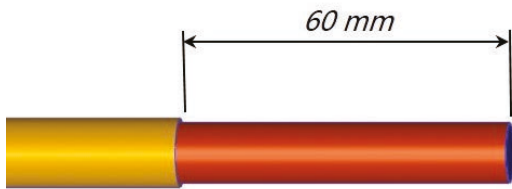

Step 2: Attach tie wrap and trim braiding flush to edge of tie-wrap

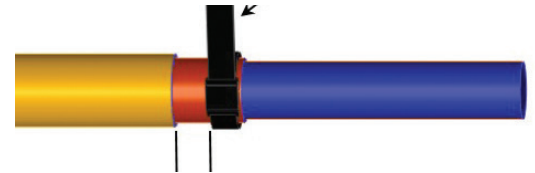

Step 3: Trim tie-wrap

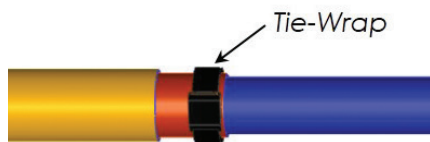

Step 4: Push cable into backshell. Slide components onto cable



Step 5: Trim jacket to conductor

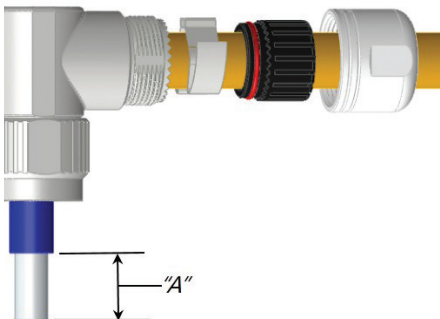

Step 6: Slide heat shrink tubing onto cable

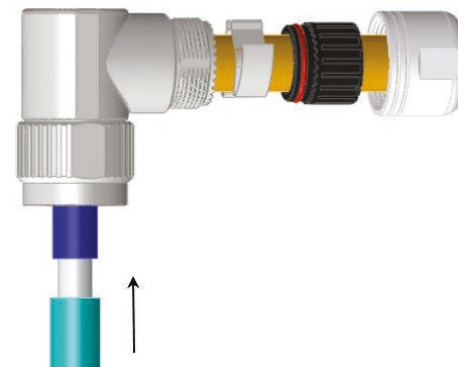

Assembly Instructions

eco | mate[®] rm High Amperage 90° Plug Cable Assembly (cont.)

Step 7: Crimp barrel to conductor

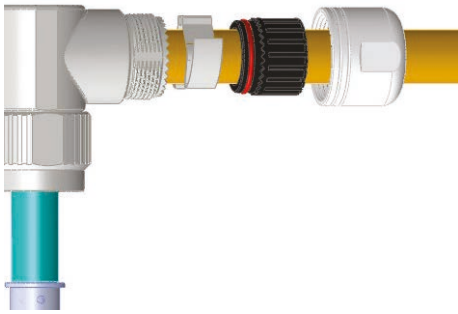

Step 8: Heat shrink tube over crimp

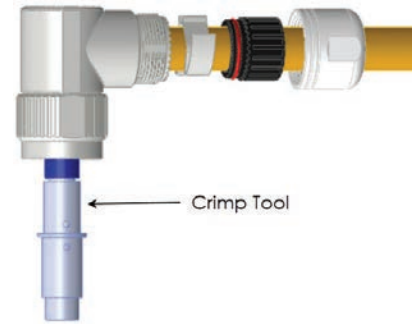

Step 9:



Step 10: Attach plug to backshell

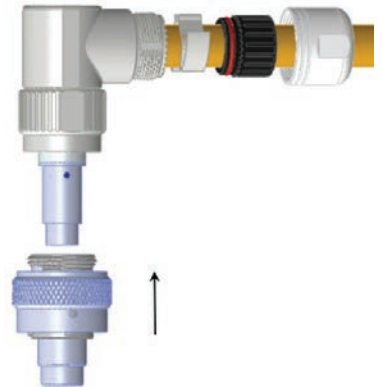

Step 11: Insert shielding clip and cable grommet. Tighten connector to backshell as shown

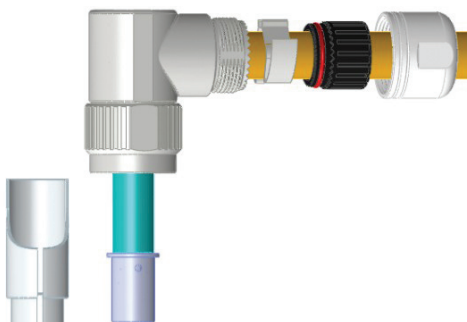

Step 12: Attach cable-nut to backshell and tighten as shown

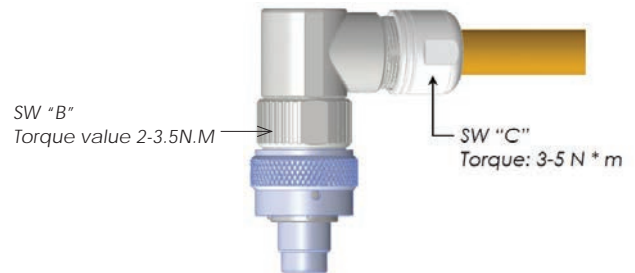

Data Chart

Instruction	Shell 12	Shell 14	Shell 16
Dimension "A"	10 mm	15 mm	15 mm
SW "B"	22 mm	25 mm	28 mm
SW "C"	22 mm	22 mm	25 mm

Technical Data

RADSOK® Product Overview

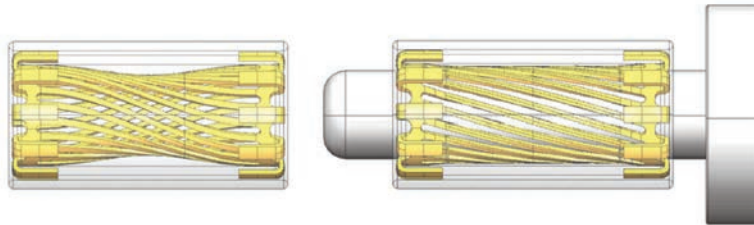

The RADSOK® Design

- Socket cylinder within female contact has several equally spaced longitudinal beams twisted into a hyperbolic shape
- As a male pin is inserted, axial members in the female half deflect, imparting high current flow across the connection with minimal voltage loss
- The hyperbolic, stamped grid configuration ensures a large, coaxial, face-to-face surface area engagement
- Ideal for crimp termination applications requiring repeated mating cycles and high current with a low multi-volt drop



RADSOK® technology is based upon a stamped and formed flat grid, uniquely twisted into a hyperbolic geometry to provide robust, high density contact to the mating pin contact. Most pin and socket technologies rely on spring (beam element) properties of the contact elements, which tend to weaken over time. Unlike most other pin and socket solutions, the RADSOK® contact also utilizes the tensile strength properties of the flat, high conductivity alloy grid. This provides the high normal forces required for conductivity while also providing a large conductive surface area. Correspondingly low voltage drop and low temperature rise are also achieved while maintaining low insertion forces.

RADSOK® Contact (Max. current carrying capacity meet DIN EN 60512 specification.)

Shell size	Applicable Cable	Contact Plating	current (AC)
			temperature
12 (3.6mm)	10mm ² , 16mm ²	Silver Plated	65A (10mm ²), 86A (16mm ²)
14 (6.0mm)	25mm ²	Silver Plated	120A (25mm ²)
16 (8.0mm)	35mm ² , 50mm ²	Silver Plated	130A (35mm ²), 180A (50mm ²)
20 (10.0mm)	50mm ² , 70mm ² , 95mm ²	Silver Plated	180A (50mm ²), 250A (70mm ²), 300A (95mm ²)

Note: The given electrical values correspond to a single contact. With the addition of a housing, an increased number of poles or other modifications, the values must be adjusted downwards accordingly.

Technical Data

RADSOK® Advantages and Custom Developed Solutions

RADSOK® Technology Advantages

- **High Reliability** - Unique design and construction technology create an electrical contact interface that exceeds typical interconnect requirements.
- **Low Contact Engagement/Separation Forces** - The hyperbolic lamella socket contact construction distributes normal forces over a high percentage of the mating pin surface. This creates a smooth, even engagement effort. This force distribution also contributes to excellent performance in vibration applications with resistance to typical fretting corrosion.
- **Low Contact Resistance** - The large interface area between the socket lamella and pin surface result in very low contact resistance, enabling the RADSOK® contacts high current ratings compared to traditional power contact designs.
- **High Mating Cycle Durability** - RADSOK® contacts with typical silver plating finishes have demonstrated survival of 20,000 mating cycles. Specialized plating and contact lubricants can extend cycle life to 200,000 matings or higher. Even with continuous exposure to harsh environmental abuse, RADSOK® contacts have been tested to maintain low contact resistance beyond 10,000 mating cycles.

Standard and Custom-Developed Solutions

- In addition to the various standard sizes of RADSOK® components, custom-developed solutions are also available. Amphenol has the global design, engineering and manufacturing resources to provide RADSOK® sockets pressed into basbars, crimped to cables, assembled into connectors, assembled into customer or Amphenol designed specialized electrical devices, or as stand-alone components. Amphenol also manufactures a full compliment of mating pin contacts for any application.
- Steady-state current capacities for RADSOK® products range from 50 amps to over 1000 amps.
- Amphenol connectors with RADSOK® contacts are offered with a variety of positive locking features (HiLok® and SurLok®) that insure and maintain fully mated connections.
- Sealing (Sealtac™) and high voltage hot break options are available within the RADSOK® itself or within a very wide range of IP rated connector housings to provide environmental protection to the contact area.

Technical Data

RADSOK® Series Rated Current and Working Voltage Contact Current Carrying Capacity

Derating 3.6mm

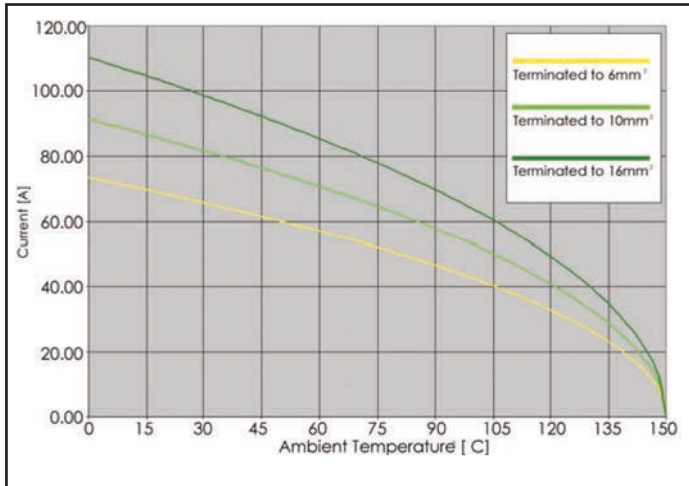

Derating 6mm

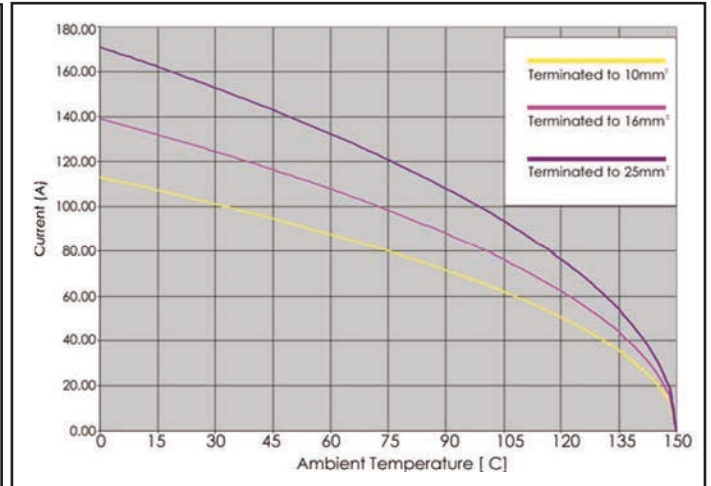

Derating 8mm

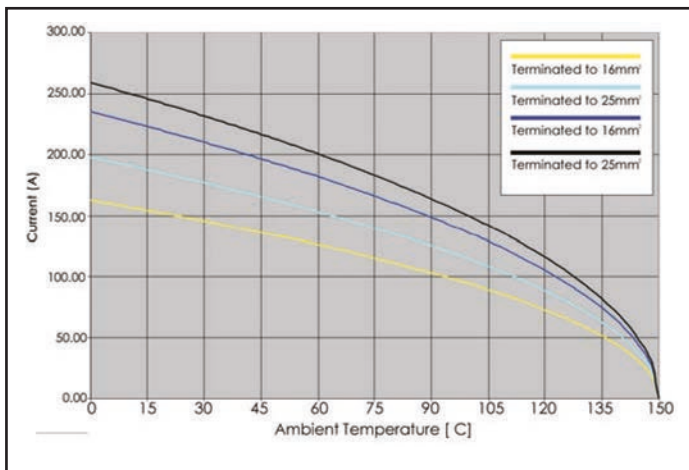

Derating 10mm

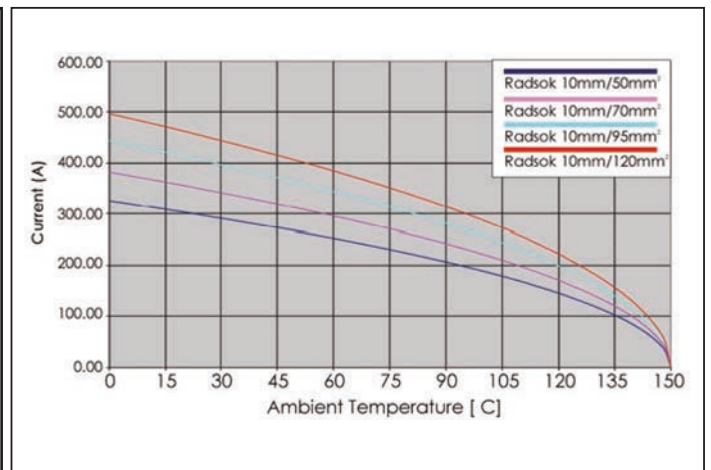

Technical Data

RADSOK® Series Dynamic Overload Tests at Different Temperatures

6mm RADSOK®

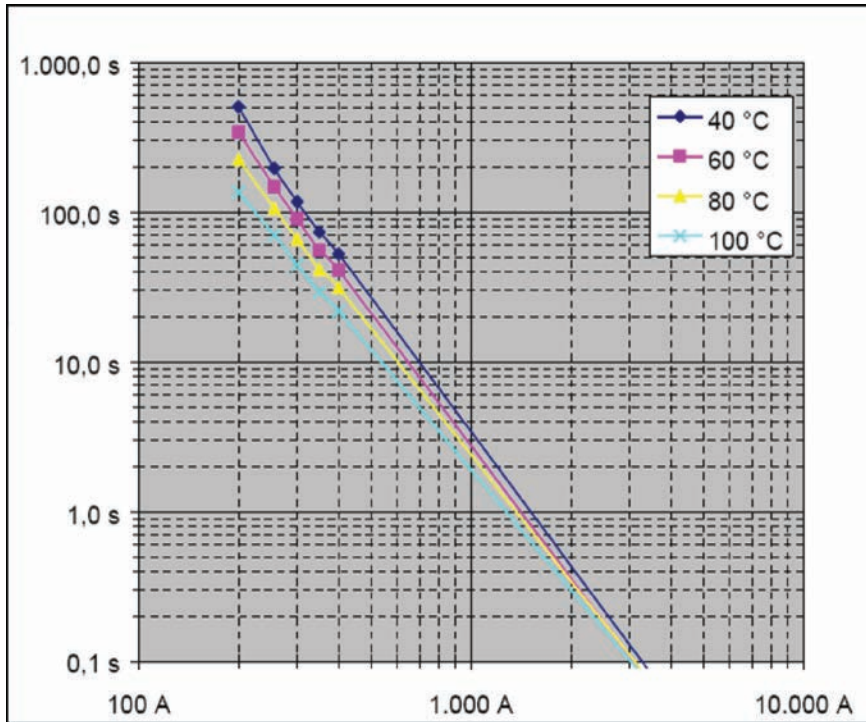

8mm RADSOK®

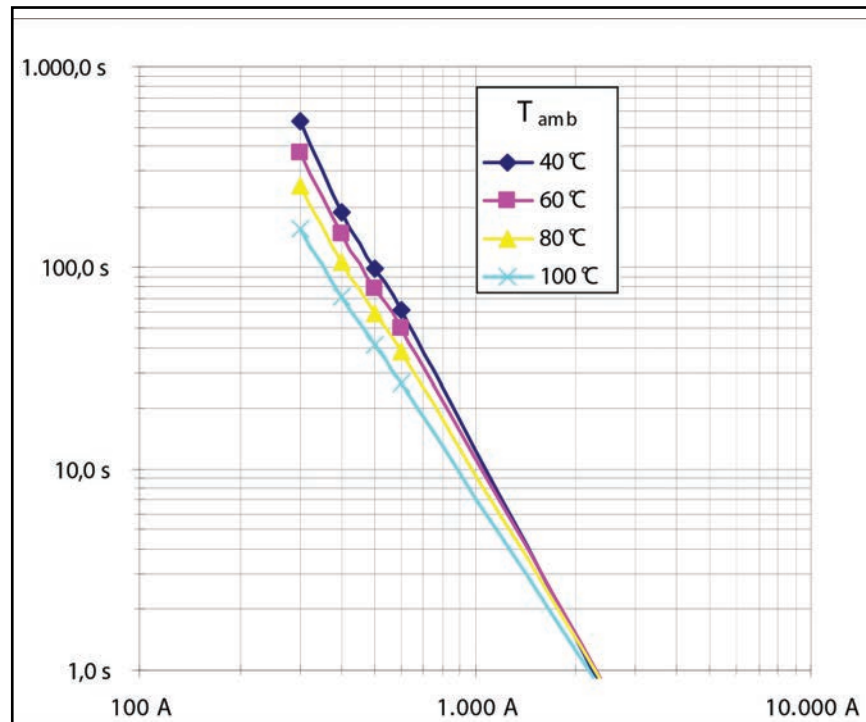

Technical Data

eco | mate[®] rm Rated Current and Working Voltage
 Current Carrying Capacity

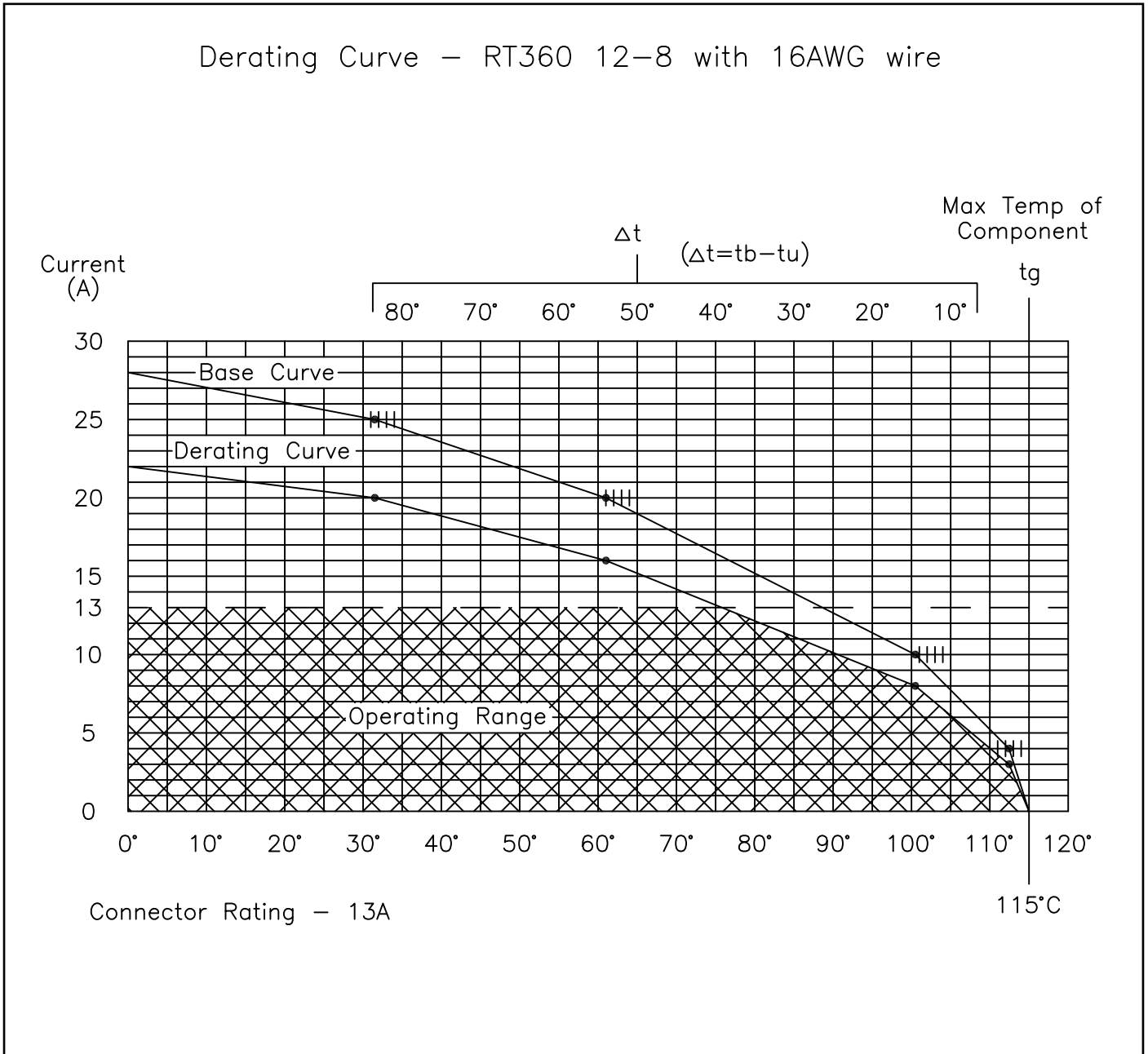

Technical Data

UL94 + UL1977 Industry Standards

There are two main standards for electrical conductors: UL94 and UL1977.

UL94 - The standard for safety of flammability of plastic material for parts in devices and appliance testing.

The eco | mate® rm series has been rated at V-0

The Test Program: Specimen is orientated in a vertical position and is subjected to a flame for ten seconds, then removed. Once the specimen has stopped burning, the flame is then reapplied for another ten seconds and then removed.

V-0 Vertical Burning

- Specimen self extinguishes within 10 seconds after each test flame application
- Specimen must not drip flaming particles that ignite the cotton indicator

UL1977 - The standard for connectors used in data, signal, control and power applications-component.

ECBT2 - A standard of UL1977 covering single and multi-pole connectors. Intended for factory assembly, includes devices that are incomplete in certain constructional features or are restricted in performance capabilities and are intended for use as components of complete equipment submitted for investigation rather than for direct separate installation in the field. The final acceptance of the component is dependent upon its installation and use in complete equipment submitted to UL.

Technical Data

IP Codes

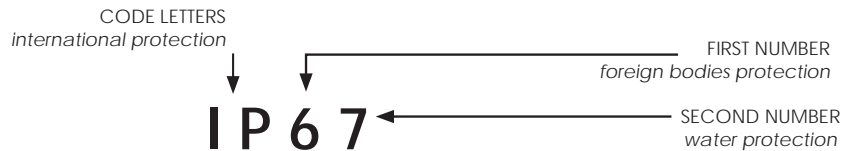

1st digit	Brief description	Definition	2nd digit	Brief Description	Definition
0	Non-protected	--	0	Non-protected	--
1	Protected against access to hazardous parts with the back of a hand. Protected against solid foreign objects of $\geq 50\text{mm } \varnothing$.	The probe, sphere of $50\text{mm } \varnothing$, shall not fully penetrate and shall have adequate clearance from hazardous parts.	1	Protected against vertically falling water drops	Vertically falling drops shall have no harmful effects.
2	Protected against access to hazardous parts with a finger. Protected against solid foreign objects of $\geq 12,5\text{mm } \varnothing$.	The jointed test finger of $12\text{mm } \varnothing$, 80mm length, shall have adequate clearance from hazardous parts. The probe, sphere of $12,5\text{mm } \varnothing$, shall not fully penetrate.	2	Protected against vertically falling water drops when enclosure tilted up to 15°	Vertically falling drops shall have no harmful effects when the enclosure is tilted at any angle up to 15° .
3	Protected against access to hazardous parts with a tool. Protected against solid foreign objects of $\geq 2,5\text{mm } \varnothing$.	The probe of $2,5\text{mm } \varnothing$ shall not penetrate at all.	3	Protected against spraying water	Water sprayed at any angle up to 60° shall have no harmful effects.
4	Protected against access to hazardous parts with a wire.	The probe of $1\text{mm } \varnothing$ shall not penetrate at all.	4	Protected against splashing water	Water splashed against the enclosure from any direction shall have no harmful effects.
5	Protected against access to hazardous parts with a wire. Dust-protected.	The probe of $1\text{mm } \varnothing$ shall not penetrate. Intrusion of dust is not totally prevented, but dust shall not penetrate in a quantity to interfere with satisfactory operation of the device or to impair safety.	5	Protected against water jets	Water projected in jets against the enclosure from any direction shall have no harmful effects.
6	Protected against access to hazardous parts with a wire. Dust-tight.	The probe of $1\text{mm } \varnothing$ shall not penetrate. No intrusion of dust.	6	Protected against powerful water jets	Water projected in powerful jets against the enclosure from any direction shall have no harmful effects.
<p>Electrical connector devices have to be protected for safety reasons from outside influences like dust, foreign objects, direct contact, moisture and water. This protection is provided on industrial connectors by the housing latching devices and sealed cable entries. The degree of protection depends on the type of intended use. The standard IEC 60529 and/or DIN EN 60529 has specified the degree of protection and divided them into several classes. The attached charts gives an overview of all of the protection degrees.</p>			7	Protected against the effects of temporary immersion in water	Intrusion of water in quantities causing harmful effects shall not be possible when the enclosure is temporarily immersed in water for 30 min. in 1m depth.
			8	Protected against the effects of continuous immersion in water	Intrusion of water in quantities causing harmful effects shall not be possible when the enclosure is continuously immersed in water under conditions which shall be agreed between manufacturer and user but which are more severe than for numeral 7.
			9K ¹⁾	Protected against water during high pressure/steam jet cleaning	Water projected in powerful jets with high pressure and heat against the enclosure from any direction shall have no harmful effects.

Technical Data

Crimp Connection

Crimp connection	Chart 2: Tensile strength for crimp connections		
	Wire size		Tensile strength
	mm ²	AWG ¹⁾	N
<p>A crimp connection is a non-detachable electrical connection between a wire and a crimp contact produced with the crimp technology. Precise crimping dies are matched to the crimp barrel and the wire size and a defined deformation results in a reliable electrical connection. There are open barrels (stamped contacts) and closed crimp barrels (turned contacts).</p> <p>The main advantages of crimp connections are:</p> <ul style="list-style-type: none"> • Efficient termination of contacts. • Reproducible electrical and mechanical figures by a constant crimp quality. <p>The requirements for crimp connections are defined in DIN EN 60352-2.</p> <p>An important point for the quality of a crimp connection is the achieved tensile strength of the termination. Measuring the tensile strength is a practical means for quality control purposes. Chart 2 below shows the required minimum tensile strength for open and closed barrels according to the wire size.</p>	0.05	30	6
	0.08	28	11
	0.12	26	15
	0.14		18
	0.22	24	28
	0.25		32
	0.32	22	40
	0.5	20	60
	0.75		85
	0.82	18	90
	1.0		108
	1.3	16	135
	1.5		150
	2.1	14	200
	2.5		230
	3.3	12	275
	4.0		310
	5.3	10	355
6.0		360	
8.4	8	370	
10.0		380	

Cross reference AWG - mm²

The chart below allows a cross reference between American Wire Gauge (AWG) and metric wire sizes (mm²).

Chart 3

AWG	Wire composition	Leiter-Ø	Wire size	AWG	Wire composition	Leiter-Ø	Wire size	
30	1 x 0.25	0.25 mm	0.05 mm ²	20	1 x 0.81	0.81 mm	0.52 mm ²	
	7 x 0.10	0.36 mm	0.06 mm ²		7 x 0.32	0.97 mm	0.56 mm ²	
28	1 x 0.32	0.32 mm	0.08 mm ²	18	19 x 0.20	1.02 mm	0.62 mm ²	
	7 x 0.13	0.38 mm	0.09 mm ²		1 x 1.02	1.02 mm	0.79 mm ²	
26	1 x 0.40	0.40 mm	0.13 mm ²	16	19 x 0.25	1.27 mm	0.96 mm ²	
	7 x 0.16	0.48 mm	0.14 mm ²		19 x 0.29	1.44 mm	1.23 mm ²	
	19 x 0.10	0.51 mm	0.15 mm ²		14	19 x 0.36	1.80 mm	1.95 mm ²
24	1 x 0.51	0.51 mm	0.21 mm ²	12	19 x 0.46	2.29 mm	3.09 mm ²	
	7 x 0.20	0.61 mm	0.23 mm ²		10	37 x 0.40	3.10 mm	4.60 mm ²
	19 x 0.13	0.64 mm	0.24 mm ²		8	133 x 0.29	4.0 mm	8.80 mm ²
22	1 x 0.64	0.64 mm	0.33 mm ²	6	133 x 0.36	5.5 mm		
	7 x 0.25	0.76 mm	0.36 mm ²					
	19 x 0.16	0.81 mm	0.38 mm ²					

It has to be noted that wires of the same AWG number but with different composition have slightly different mm².

Technical Data

Composition and Dimensions of Copper Wires

Chart 4: Composition and Dimensions of Copper Wires

Wire Size	Wire Composition	Wire diameter
0.09 mm ²	12 x 0.10	0.48 mm
0.14 mm ²	18 x 0.10	0.50 mm
0.25 mm ²	14 x 0.15	0.70 mm
0.34 mm ²	7 x 0.25	0.78 mm
0.5 mm ²	16 x 0.20	1.0 mm
0.75 mm ²	24 x 0.20	1.2 mm
1.0 mm ²	32 x 0.20	1.4 mm
1.5 mm ²	30 x 0.25	1.6 mm
2.5 mm ²	35 x 0.30	2.2 mm
4.0 mm ²	56 x 0.30	2.8 mm
6.0 mm ²	19 x 0.64	3.4 mm
10 mm ²	19 x 0.80	4.3 mm

Current carrying capacity

The current carrying capacity of a connector is shown by a derating curve. The curve shows the currents that the connector can carry continuously and simultaneously through all its contacts. The curve is determined by testing following the standard DIN EN 60512. The upper temperature is limited by the contact and insulation material used. The sum of the ambient temperature and the temperature created by the current flow may not exceed the upper temperature. This means that the current carrying capacity has no fixed value but decreases with increasing ambient temperatures.

As a general example it can be said that a given connector which can carry 16A through all its contacts at 40°C ambient temperature can carry less, e.g. 12A, at an ambient temperature of 80°C. On the other hand it is often the case that not all contacts carry the whole rated current, which means that some single contacts may carry a higher current than that according to the derating curve. These currents have to be defined by testing.

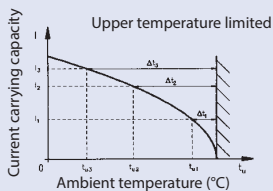
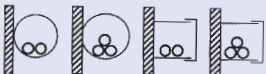
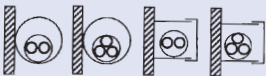



Chart 5: Current carrying capacity of copper wires in (A)

Installation type	Wire size (mm ²)	0.25	0.34	0.5	0.75	1	1.5	2.5	4	6	10
 B1 Wires in conduits and installation channels		-	-	-	7.6	10.4	13.5	18.3	25	32	44
 B2 Cables and conductors in conduits or installation channels		-	-	-	-	9.6	12	16.5	23	29	40
 C Cables and conductors along walls		4.0	5.0	7.1	9.1	11.7	15.2	21	28	36	50
 E Cables and conductors on plank		4.0	5.0	7.1	9.1	11.5	16.1	22	30	37	52

Description according to DIN EN 60204 for PVC insulated copper wires with a working temperature of +40C. For other requirements,

such as for other temperatures, mountings, or wires corresponding correction factors are used (see next page).

Technical Data

Reduction Values

Reduction values	Chart 6	
<p>The values in chart 5 are based on an ambient temperature of 40 °C. For other ambient temperatures the values have to be adjusted using the correction values of chart 6 below.</p> <p>For installations with many cables and conductors under load the current carrying capacity is reduced according to the two following charts 7 and 8.</p>	Ambient temperature (°C)	Correction value
	30	1.15
	35	1.03
	40	1.00
	45	0.91
	50	0.82
	55	0.71
	60	0.58

Chart 7: Reduction values for accumulated conductors

Installation type	Number of cables and conductors / pairs under load			
	2	4	6	9
Three phase cable and conductor				
B1 and B2	0.80	0.85	0.87	0.86
C	0.65	0.75	0.78	0.76
E-one row	0.57	0.72	0.75	0.72
E-multi row	0.50	0.70	0.73	0.88
DC conductor (pair), independent of installation type	1.0	0.76	0.64	0.43

Chart 8: Reduction values for multicore cable and conductors up to 10mm²

Number of conductors (pairs) under load	AC (conductor > 1 mm ²)	DC (Pairs 0,2 to 0,75 mm ²)
5	0.75	0.52
7	0.65	0.45
10	0.55	0.39
24	0.40	0.27

Conductors of control circuits generally do not need a reduction.

Impulse current carrying capacity

A surge can happen to a connector and its contacts by an impulse current, e.g. through a short circuit in the system or by switching operations. The short-timed high current heat cannot be transferred outside fast enough so the contacts

are stressed by the high temperature which in the worst case can lead to a local weld. The robust design of our connectors prevents most damage by impulse currents.

Voltage grading of connectors

General

Clearances and creepage distances are the base for voltage grading of connectors. Valuation and dimensioning of clearances and creepage distances have changed since the introduction of insulation coordination.

Insulation coordination comprises the selection of the electrical insulation performances of the equipment, taking into account the expected use and its environment.

The following standards apply for this:

IEC 60664-1/10.92
Insulation coordination for equipment within low-voltage systems

DIN VDE 0110-1/4.97
Isolationskoordination für elektrische Betriebsmittel in Niederspannungsanlagen

Technical Data

Voltage Grading of Connectors

Clearances					
<p>The clearance is the shortest distance in air between two conductive parts. An important point for the dimensioning of clearances is the determination of the overvoltage category. The above standard specifies the possible overvoltages into the four following categories:</p> <p>Overvoltage category I Equipment intended for the use in appliances or parts of installations in which no overvoltage can occur. Examples are low-voltage equipment.</p> <p>Overvoltage category II Equipment intended for the use in installations or parts of it in which lightning overvoltages do not need to be considered, but switching overvoltages generated by the equipment do need to be considered. Examples are household appliances.</p> <p>Once the overvoltage category has been defined the rated impulse withstand voltage can be selected for the equipment based on the nominal voltage of the supply system and the overvoltage category using chart 9 below:</p>		<p>Overvoltage category III Equipment intended for the use in installations or parts of it in which lightning overvoltages do not need to be considered, however switching overvoltages generated by the equipment, and for cases where the reliability and the availability of the equipment or its dependent circuits are subject to special requirements. Examples are protecting means, switches and sockets.</p> <p>Overvoltage category IV Equipment intended for the use in installations or parts of it in which lightning overvoltage has to be considered. Examples are electricity meters, overcurrent protection switches.</p>			
Chart 9					
Nominal voltage of the supply system in V (based on IEC 60038)		Rated impulse voltage in kV for overvoltage category			
Three phase systems		IV	III	II	I
230/400 277/480		6	4	2,5	1,5
400/690		8	6	4	2,5
1000		12	8	6	4
<p>After the rated impulse withstand voltage has been selected the pollution degree must be defined taking the expected pollution around the equipment into account. The following four degrees of pollution are established: After the rated impulse withstand voltage has been selected the pollution degree must be defined taking the expected pollution around the equipment into account. The following four degrees of pollution are established:</p> <p>Pollution degree 1 No pollution or only dry, non-conductive pollution occurs. The pollution has no influence.</p> <p>Pollution degree 2 Only non-conductive pollution occurs except occasionally a temporary conductivity caused by condensation is to be expected.</p> <p>Pollution degree 3 Conductive pollution occurs or dry non-conductive pollution occurs which becomes conductive due to condensation which is to be expected.</p>		<p>Pollution degree 4 The pollution generates persistent conductivity caused by conductive dust or by rain or snow.</p> <p> It has to be noted that for a connector or plug and socket device with a degree of protection of min. IP 54 the parts inside the enclosure may be dimensioned for a lower pollution degree. This also applies to mated connectors which enclosure is ensured through the connector housing and which may only be disengaged for test and maintenance purposes. When impulse withstand voltage and the pollution degree are defined the minimum clearances can be selected from chart 10.</p>			

Technical Data

Voltage Grading of Connectors (cont.)

Chart 10

Impulse withstand voltage in kV	Minimum clearances in air in mm up to 2000 m above sea level							
	Case A (non homogeneous field)				Case B (homogeneous field)			
	Pollution degree				Pollution degree			
	1	2	3	4	1	2	3	4
0.33	0.01	0.2	0.8	1.6	0.01	0.2	0.8	1.6
0.40	0.02				0.02			
0.50	0.04				0.04			
0.60	0.06				0.06			
0.80	0.10				0.1			
1.0	0.15				0.15			
1.2	0.25	0.25	1.0	2	0.2	0.3	1.2	
1.5	0.5				0.3			
2.0	1.0	1.0	0.45	0.45	0.6	0.6	1.5	
2.5	1.5	1.5	1.5	2	0.8	0.8	2	
3.0	2	2	2	3	1.2	1,2	3	
4.0	3	3	3	4	1.5	1.5	4	
5.0	4	4	4	5.5	2	2	5.5	
6.0	5.5	5.5	5.5	8	3	3	8	
8.0	8	8	8	11	3.5	3.5	11	
10	11	11	11	14	4.5	4.5	14	
12	14	14	14	18	5.5	5.5	18	
15	18	18	18	25	8	8	25	
20	25	25	25	33	10	10	33	
25	33	33	33	40	12.5	12.5	40	
30	40	40	40	60	17	17	60	
40	60	60	60	75	22	22	75	
50	75	75	75	90	27	27	90	
60	90	90	90	130	35	35	130	
80	130	130	130	170	45	45	170	
100	170	170	170					

When defining the minimum clearances for connectors generally the values of the inhomogeneous field can be chosen or the required clearance has to be defined by a voltage test.

Creepage distances

The creepage distance is the shortest distance along the surface of the insulating material between two conductive parts. For the dimensioning of the creepage distance the following factors are taken into account: the rated voltage, the pollution degree and the tracking formation of the insulating material.

The materials are separated into four groups according to their CTI values (Comparative Tracking Index):

- Material group I $600 \leq CTI$
- Material group II $400 \leq CTI < 600$
- Material group IIIa $175 \leq CTI < 400$
- Material group IIIb $100 \leq CTI < 175$

The minimum creepage distances can be selected from chart 11 .

Technical Data

Creepage Distance

Chart 11

U-eff Rated voltage U in V	Min. creepage distance in mm														
	Printed circuits		Other devices												
	Pollution degree		Pollution degree				Pollution degree				Pollution degree				
	1	2	1	2			3				4				
	2)	3)	2)	I	II	IIIa	IIIb	I	II	IIIa	IIIb	I	II	IIIa	IIIb
10	0.025	0.04	0.08	0.4	0.4	0.4		1	1	1		1.6	1.6	1.6	
12.5	0.025	0.04	0.09	0.42	0.42	0.42		1.05	1.05	1.05		1.6	1.6	1.6	
16	0.025	0.04	0.1	0.45	0.45	0.45		1.1	1.1	1.1		1.6	1.6	1.6	
20	0.025	0.04	0.11	0.48	0.48	0.48		1.2	1.2	1.2		1.6	1.6	1.6	
25	0.025	0.04	0.125	0.5	0.5	0.5		1.25	1.25	1.25		1.7	1.7	1.7	
32	0.025	0.04	0.14	0.53	0.53	0.53		1.3	1.3	1.3		1.8	1.8	1.8	
40	0.025	0.04	0.16	0.56	0.8	1.1		1.4	1.6	1.8		1.9	2.4	3	
50	0.025	0.04	0.18	0.6	0.85	1.2		1.5	1.7	1.9		2	2.5	3.2	
63	0.04	0.063	0.2	0.63	0.9	1.25		1.6	1.8	2		2.1	2.6	3.4	
80	0.063	0.1	0.22	0.67	0.95	1.3		1.7	1.9	2.1		2.2	2.8	3.6	
100	0.1	0.16	0.25	0.71	1	1.4		1.8	2	2.2		2.4	3.0	3.8	
125	0.16	0.25	0.28	0.75	1.05	1.5		1.9	2.1	2.4		2.5	3.2	4	
160	0.25	0.4	0.32	0.8	1.1	1.6		2	2.2	2.5		3.2	4	5	
200	0.4	0.63	0.42	1	1.4	2		2.5	2.8	3.2		4	5	6.3	
250	0.56	1	0.56	1.25	1.8	2.5		3.2	3.6	4		5	6.3	8	
320	0.75	1.6	0.75	1.6	2.2	3.2		4	4.5	5		6.3	8	10	
400	1	2	1	2	2.8	4		5	5.6	6.3		8	10	12.5	
500	1.3	2.5	1.3	2.5	3.6	5		6.3	7.1	8.0		10	12.5	16	
630	1.8	3.2	1.8	3.2	4.5	6.3		8	9	10		12.5	16	20	
800	2.4	4	2.4	4	5.6	8		10	11	12.5		16	20	25	
1000	3.2	5	3.2	5	7.1	10		12.5	14	16		20	25	32	
1250			4.2	6.3	9	12.5		16	18	20		25	32	40	
1600			5.6	8	11	16		20	22	25		32	40	50	
2000			7.5	10	14	20		25	28	32		40	50	63	
2500			10	12.5	18	25		32	36	40		50	63	80	
3200			12.5	16	22	32		40	45	50		63	80	100	
4000			16	20	28	40		50	56	63		80	100	125	
5000			20	25	36	50		63	71	80		100	125	160	
6300			25	32	45	63		80	90	100		125	160	200	
8000			32	40	56	80		100	110	125		160	200	250	
10000			40	50	71	100		125	140	160		200	250	320	

Connectors in this catalogue are allocated to fixed rated voltages which apply to the machine building industry. In case of other applications the above chart can be used to determine other rated voltages.

Appendix

Glossary of Terms

American Wire Gauge (AWG)	Connector life
System of numerical designations for wire sizes, based on specified ranges of cross-sectional areas. Starts with 4/0 (000) at the largest size, going to 3/0, 2/0, 1/0, 1, 2, and up to 40 and beyond for the smallest size. A step of one AWG number corresponds to a reduction of cross-sectional area of appr. 20 %.	The number of mating cycles prior to abrasion of the conductive contact surface and which does not result in a significant rise of the contact resistance. Tests according to test 9a of ICE 60512-5 / DIN EN 60512 Part 5.
Attenuation	Contact
A reduction of power. Occurs naturally when waves travel through lines, wave guides, or media such as air or water. Is produced additionally by imperfections in electrical or optical connections (attenuation in fibre optics), e. g. contact resistance, mismatch, etc.	The conductive element in a connector which mates with a corresponding element to provide an electrical path.
Bulkhead connector	Contact resistance
Connector designed to be inserted into a panel cutout from the rear of the panel, thus forming part of the barrier between two spaces. Back-mounted.	The electrical resistance of a mated set of contacts under specified conditions. Tested according to tests 2a, 2b, 2c, of IEC 60 512 -2/ DIN EN 60 512-2.
Clearance	Contact size
The shortest distance in air between two conductive parts, see IEC 60664.	The designation used to differentiate one contact from another. It may be denoted by one of the following numbering systems:
Climatic stability	Creepage distance
General term describing the behavior of components under various climatic conditions, e. g. high and low temperatures, tropical climate, high humidity, moist heat, fungus, atmospheric conditions (industrial atmosphere), reduced air pressure, etc. Climatic conditions for test purposes are explained in IEC 60068, DIN 46 040.	The shortest distance along the surface of the insulating material between two conductive parts. The longer the distance, the less the risk of arc damage or tracking. Minimum creepage distances are specified according to the rated voltage and the applicable pollution degree and Comparative Tracking Index.
Connector	Crimped connection
A component which terminates conductors for the purpose of providing connection and disconnection to a suitable mating component which shall not be engaged or disengaged when live. Depending on the fastening to a cabinet, panel, rack etc. or a cable, they are classified as fixed or free connectors. A connector comprises one or more contacts and a housing which may have a separate connector insert and a separate outer housing or shell.	A solderless connection made by crimping. IEC 60352-2 / DIN IEC 60352 Part 2.
Connector housing	Derating curve
The part of a connector into which the insert and the contacts are assembled. It may function as part of the locking mechanism.	The method for determining derating is specified in IEC 60 512-3. Here the combination of ambient temperature (Tu) and the current (J) leading to the same maximum allowable temperature (Tb) at the hottest point of the connector are plotted.
Connector insert	DIN
An insulating element designed to support and position contacts in a connector housing. In connectors electromagnetic interference is prevented by shielding. Shielded connectors normally provide means to connect the screens of attached cables.	Deutsches Institut für Normung. A German standards organization.
	Electromagnetic interference (EMI)
	General term describing the undesirable effects of the immission or emission of radio frequency fields.
	Funnel entry (restricted entry C146 D series)
	Flared or widened entrance to a conductor barrel permitting easier insertion of the conductor.
	Insertion or withdrawal force
	The force required to fully insert or withdraw a set of mated connectors without the effect of coupling, locking or similar devices. The insertion force is usually greater than the withdrawal force.

Appendix

Connector Glossary

Insulation grip	Shield, shielding
The area of a crimp contact that has been reshaped around the insulation of the conductor by compression during the crimping operation.	Shielding of internal or external electric fields by means of a plane with a uniform electric potential, formed by metal shells or metallic layers on the inside or outside of plastic shells. The shield is normally connected to the shielding braid of the cable and/or chassis ground.
Insulation resistance	Terminal block
The resistance of the insulation between two conductive elements, in particular, the resistance between two contacts or between a contact and a metallic housing or shield. Tested according to test 3a of IEC 60512-2 / DIN IEC 60512 Part 2.	An assembly of terminals in a housing or body of insulating material to facilitate interconnection between multiple conductors. Also called terminal strip or barrier blocks if the terminals are separated by an insulation barrier.
Intermateable	Wire range
Two connectors are intermateable when they are capable of being connected electrically and mechanically but without regard to their performance and intermountability.	The range of wire cross sections which is compatible with the dimensions the terminals of the contact (wire barrel). The wire range is expressed in mm ² or in AWG numbers.
Locator	
In a crimping tool the device used for positioning a crimp contact or terminal end.	
Locking lever	
A mechanical locking device operated by actuating a lever, designed to hold two mated connectors together. Typically the lever can only be fully locked if the two connectors are correctly mated.	
Mating cycle	
One mating cycle comprises one insertion and one withdrawal operation. Term used in the definition of connector life.	
Material group	
Classification of insulation materials according to their CTI values (CTI = Comparative Tracking Index)	
Overvoltage category	
A numeral defining a transient overvoltage condition. Overvoltage categories I, II, III and IV are used.	
Connector with braking capacity (CBC)	
A component which may be engaged or disengaged in normal use, when live or under load. Note: In the sense of this document the term - live- is used if contacts are under voltage not necessarily with a current flowing across the contacts. The term - load - is used if a current is flowing across the contacts.	
Rated current	
A current value assigned by the manufacturer which the connector or PSD can carry continuously (without interruption) and simultaneously through all its contacts wired with the largest conductor preferably at an ambient temperature of 40 °C without the upper temperature being exceeded.	

Appendix

Part Number Index (1-MS)

108039110.....	33,41,75	MFX-3957.....	27,34,45,53	MP16M12E09G5.....	205	MP28W23G5.....	43,76,116,
108039112.....	25,51,83,		77,85,93,109,	MP16M12E09G10.....	205		132,156,172,208
	91,115		117,125,133,141,	MP16M12E09G15.....	205	MP28W23G10.....	43,76,116,
108039114.....	61,123,131,		149,157,165,173,	MP16M12E09G30.....	205		132,156,172,208
	171		177,212	MP16M23F.....	26,34,42,	MP28W23G15.....	43,76,116,
108039116.....	69,107,139,	MFX-3958.....	45,77,117,		52,84,92,		132,156,172,208
	155		133,157,173,212		108,124,140,	MP28W23G30.....	43,76,116,
108039118.....	101,147	MFX-3959.....	26,35,43		148,164,176,207		132,156,172,208
108039120.....	163		52,76,84,92,108,	MP16M23G5.....	26,34,42,	MS6ARS8S.....	210
108039122.....	174		116,124,132,140,		52,84,92,	MS10A23S.....	68,207
CA401259.....	61,101,107,		148,156,164,172,176,212		108,124,140,	MS10B12E05F.....	205
	171	MFX-3960.....	26,35,43,52,		148,164,176,207	MS10B12E05G5.....	205
CA401659.....	25,33,41,51,		76,84,92,108,	MP16M23G10.....	26,34,42,	MS10B12E05G10.....	205
	83,91,107,139,		116,124,132,140,		52,84,92,	MS10B12E05G15.....	205
	147,163,171,174		148,156,164,172,		108,124,140,	MS10B12E05G30.....	205
CA402059.....	41,75,115,		176,212		148,164,176,207	MS10B12E08F.....	205
	123,131,155	MFX-3962.....	53,60,100,	MP16M23G15.....	26,34,42,	MS10B12E08G5.....	205
HP10ACS.....	210,214		109,212		52,84,92,	MS10B12E08G10.....	205
HP25BCS.....	183,210	MP10A23S.....	68,207		108,124,140,	MS10B12E08G15.....	205
HP35CCS.....	187,210	MP10B12E05F.....	205	MP16M23G30.....	26,34,42,	MS10B12E08G30.....	205
HP50CCS.....	187,210	MP10B12E05G5.....	205		52,84,92,	MS14M23F.....	26,34,42,
HP50DCS.....	191,210	MP10B12E05G10.....	205		108,124,140,		52,84,92,
HP70DCS.....	191,210	MP10B12E05G15.....	205		148,164,176,207		108,124,140,
HP95DCS.....	191,210	MP10B12E05G30.....	205	MP24M23F.....	26,34,42,52,		148,164,176,207
HPAHS.....	179,210	MP10B12E08F.....	205		84,92,108,124,	MS14M23G5.....	26,34,42,
HPASS.....	210	MP10B12E08G5.....	205		140,148,164,176,208		52,84,92,
HPBHS.....	183,210	MP10B12E08G10.....	205	MP24M23G5.....	26,34,42,52,		108,124,140,
HPBSS.....	183,210	MP10B12E08G15.....	205		84,92,108,		148,164,176,207
HPCHS.....	187,210	MP10B12E08G30.....	205		124,140,148,	MS14M23G10.....	26,34,42,
HPCSS.....	187,210	MP14M23F.....	26,34,42,		164,176,208		52,84,92,
HPDHS.....	191,210		52,84,92,	MP24M23G10.....	26,34,42,52,		108,124,140,
HPDSS.....	191,210		108,124,140,		84,92,108,		148,164,176,207
HS10ACS.....	210,214		148,164,176,207		124,140,148,	MS14M23G15.....	26,34,42,
HS25BCS.....	183,210	MP14M23G5.....	26,34,42		164,176,208		52,84,92,
HS25CCS.....	187,210		52,84,92,	MP24M23G15.....	26,34,42,52,		108,124,140,
HS25DCS.....	191,210		108,124,140,		84,92,108,		148,164,176,207
HS35CCS.....	187,210		148,164,176,207		124,140,148,	MS14M23G30.....	26,34,42,
HS35DCS.....	191,210	MP14M23G10.....	26,34,42,		164,176,208		52,84,92,
HS50CCS.....	187,210		52,84,92,	MP24M23G30.....	26,34,42,52,		108,124,140,
HS50DCS.....	191,210		108,124,140,		84,92,108,		148,164,176,207
HS70DCS.....	191,210		148,164,176,207		124,140,148,	MS16M12E06F.....	204
HS95DCS.....	191,210	MP14M23G15.....	26,34,42,		164,176,208	MS16M12E06G5.....	204
HPAHS.....	210		52,84,92,	MP24W23F.....	43,76,116,132,	MS16M12E06G10.....	204
HPASS.....	210		108,124,140,		156,172,208	MS16M12E06G15.....	204
HPBHS.....	210		148,164,176,207	MP24W23G5.....	43,76,116,	MS16M12E06G30.....	204
HPBSS.....	210	MP14M23G30.....	26,34,42,		132,156,172,208	MS16M12E09F.....	204
HSCHS.....	210		52,84,92,		132,156,172,208	MS16M12E09G5.....	205
HSCSS.....	210		108,124,140,	MP24W23G10.....	43,76,116,	MS16M12E09G10.....	205
HSDHS.....	210		148,164,176,207		132,156,172,208	MS16M12E09G15.....	205
HSDSS.....	210	MP16M12E06F.....	204	MP24W23G15.....	43,76,116,	MS16M12E09G30.....	205
MFX-3954.....	27,34,45,53	MP16M12E06G5.....	204		132,156,172,208	MS16M23F.....	26,34,42,
	85,93,109,125,	MP16M12E06G10.....	204	MP24W23G30.....	43,76,116,		52,84,92,
	141,149,165,177,212	MP16M12E06G15.....	204		132,156,172,208		108,124,140,
		MP16M12E06G30.....	204	MP28W23F.....	43,76,116,		148,164,176,207
		MP16M12E09F.....	204		132,156,172,208		

Appendix

Part Number Index (MS -RTOW)

MS16M23G5.....26,34,42, 52,84,92, 108,124,140, 148,164,176,207	MS20W23G30...43,76,116, 132,156,172,208	RB00011910.....33,41,75	RTOW01210PNH.....111
MS16M23G10.....26,34,42, 52,84,92, 108,124,140, 148,164,176,207	MS24M23F.....26,34,42,52, 84,92,108, 124,140,148, 164,176,208	RB00011912.....25,83,115	RTOW01210PNHEC.....111
MS16M23G15.....26,34,42, 52,84,92, 108,124,140, 148,164,176,207	MS24M23G5.....26,34,42,52, 84,92,108, 124,140,148, 164,176,208	RB00011914.....51,61,91, 123,131	RTOW01210PNHK.....111
MS16M23G30.....26,34,42, 52,84,92, 108,124,140, 148,164,176,207	MS24M23G10.....26,34,42, 52,84,92, 108,124,140,148, 164,176,208	RB00011916.....69,107, 139,155	RTOW01210SNH.....111
MS20M23F.....26,34,42, 52,84,92, 108,124,140, 148,164,176,207	MS24M23G15.....26,34,42, 52,84,92, 108,124,140,148, 164,176,208	RB00011918.....101,147,171	RTOW01210SNHEC.....111
MS20M23G5.....26,34,42, 52,84,92, 108,124,140, 148,164,176,207	MS24M23G30.....26,34,42, 52,84,92, 108,124,140,148, 164,176,208	RB00011920.....163	RTOW01210SNHK.....111
MS20M23G10.....26,34,42, 52,84,92, 108,124,140, 148,164,176,207	MS24W23F.....43,76,116, 132,156,172,208	RTOB12CGNS1.....21,79,111	RTOW01419PNH.....127
MS20M23G15.....26,34,42, 52,84,92, 108,124,140, 148,164,176,207	MS24W23G5.....43,76,116, 132,156,172,208	RTOB12CGNS2.....21,79,111	RTOW01419PNHEC.....127
MS20M23G30.....26,34,42, 52,84,92, 108,124,140, 148,164,176,207	MS24W23G10...43,76,116, 132,156,172,208	RTOB14CGNS1.....47,55, 87,119,127	RTOW01419PNHK.....127
MS20W12E06F.....204	MS24W23G15.....43,76,116, 132,156,172,208	RTOB14CGNS2.....47,55, 87,119,127	RTOW01419SNH.....127
MS20W12E06G5.....204	MS24W23G30...43,76,116, 132,156,172,208	RTOB16CGNS1.....63,103, 135,151	RTOW01419SNHEC.....127
MS20W12E06G10.....204	MS28W23F.....43,76,116, 132,156,172,208	RTOB16CGNS2.....63,103, 135,151	RTOW01626PNH.....151
MS20W12E06G15.....204	MS28W23G5.....43,76,116, 132,156,172,208	RTOL10CGNS1.....29,37,71	RTOW01626PNHEC.....151
MS20W12E06G30.....204	MS28W23G10...43,76,116, 132,156,172,208	RTOL10CGNS2.....29,37,71	RTOW01626PNHK.....151
MS20W12E09F.....204	MS28W23G15...43,76,116, 132,156,172,208	RTOL12CGNS1.....21,79,111	RTOW01626SNH.....151
MS20W12E09G5.....204	MS28W23G30...43,76,116, 132,156,172,208	RTOL12CGNS2.....21,79,111	RTOW01626SNHEC.....151
MS20W12E09G10.....204	QXRT08.....68	RTOL14CGNS1.....47,55,87, 119,127	RTOW01626SNHK.....151
MS20W12E09G15.....204	QXRT08R.....68	RTOL14CGNS2.....47,55,87, 119,127	RTOW01832PNH.....167
MS20W12E09G30.....204	QXRT12S.....52,53,60, 100,109	RTOL16CGNS1.....63,103, 135,151	RTOW01832PNHEC.....167
MS20W23F.....43,76,116, 132,156,172,208	QXRT16.....26,27,34,35, 43,45,53,84,85,92, 93,108,109,124,125, 140,141,148,149,164, 165,176,177	RTOL16CGNS2.....63,103, 135,151	RTOW01832SNH.....167
MS20W23G5.....43,76,116, 132,156,172,208	QXRT20.....43,45,76,77, 116,117,132,133, 156,157,172,173	RTOL18CGNS1.....95,143,167	RTOW01832SNHEC.....167
MS20W23G10...43,76,116, 132,156,172,208		RTOL18CGNS2.....95,143,167	RTOW01832SNHK.....167
MS20W23G15...43,76,116, 132,156,172,208		RTOL20CPGS5.....159	RTOW6106PNH.....71
		RTOL20CPGS6.....159	RTOW6106PNHEC.....71
		RTOS10CGNS1.....29,37,71	RTOW6106PNHK.....71
		RTOS10CGNS2.....29,37,71	RTOW6106SNH.....71
		RTOS12CGNS1.....21,79,111	RTOW6106SNHEC.....71
		RTOS12CGNS2.....21,79,111	RTOW6106SNHK.....71
		RTOS14CGNS1.....47,55,87, 119,127	RTOW61210PNH.....111
		RTOS14CGNS2.....47,55,87, 119,127	RTOW61210PNHEC.....111
		RTOS16CGNS1.....63,103, 135,151	RTOW61210PNHK.....111
		RTOS16CGNS2.....63,103, 135,151	RTOW61210SNH.....111
		RTOS18CGNS1.....95,143,167	RTOW61210SNHEC.....111
		RTOS18CGNS2.....95,143,167	RTOW61210SNHK.....111
		RTOW0106PNH.....71	RTOW61419PNH.....127
		RTOW0106PNHEC.....71	RTOW61419PNHEC.....127
		RTOW0106PNHK.....71	RTOW61419PNHK.....127
		RTOW0106SNH.....71	RTOW61419SNH.....127
		RTOW0106SNHEC.....71	RTOW61419SNHEC.....127
		RTOW0106SNHK.....71	RTOW61419SNHK.....127
			RTOW61626PNH.....151
			RTOW61626PNHEC.....151
			RTOW61626PNHK.....151
			RTOW61626SNH.....151
			RTOW61626SNHEC.....151
			RTOW61626SNHK.....151

Appendix

Part Number Index (RT0W -RT0)

RT0W61832PNH.....	167	RT00102PNHEC.....	37	RT610DCG.....	75	RT002028SNH.....	159
RT0W61832PNHEC.....	167	RT00102PNHEC.....	37	RT612DC.....	25	RT002028SNHEC.....	159
RT0W61832PNHK.....	167	RT00102PNHK.....	37	RT612DC.....	83	RT002028SNHK.....	159
RT0W61832SNH.....	167	RT00102SNH.....	37	RT612DC.....	115	RT002448PNH.....	174
RT0W61832SNHEC.....	167	RT00102SNHEC.....	37	RT612DCG.....	25	RT002448SNH.....	174
RT0W61832SNHK.....	167	RT00102SNHEC.....	37	RT612DCG.....	83	RT06102PNH.....	37
RT0W71210PNH.....	111	RT00102SNHK.....	37	RT612DCG.....	115	RT06102PNHEC.....	37
RT0W71210PNHEC.....	111	RT00104PNH.....	29	RT614DC.....	51	RT06102SNH.....	37
RT0W71210PNHK.....	111	RT00104PNHEC.....	29	RT614DC.....	61	RT06102SNHEC.....	37
RT0W71210SNH.....	111	RT00104PNHK.....	29	RT614DC.....	91	RT06104PNH.....	29
RT0W71210SNHEC.....	111	RT00104SNH.....	29	RT614DC.....	123	RT06104PNHEC.....	29
RT0W71210SNHK.....	111	RT00104SNHEC.....	29	RT614DC.....	131	RT06104PNHK.....	29
RT0W71419PNH.....	127	RT00104SNHK.....	29	RT614DCG.....	51	RT06104SNH.....	29
RT0W71419PNHEC.....	127	RT00123PNH.....	21	RT614DCG.....	61	RT06104SNHEC.....	29
RT0W71419PNHK.....	127	RT00123PNHEC.....	21	RT614DCG.....	91	RT06104SNHK.....	29
RT0W71419SNH.....	127	RT00123PNHK.....	21	RT614DCG.....	123	RT06123PNH.....	21
RT0W71419SNHEC.....	127	RT00123SNH.....	21	RT614DCG.....	131	RT06123PNHEC.....	21
RT0W71419SNHK.....	127	RT00123SNHEC.....	21	RT616DC.....	69	RT06123PNHK.....	21
RT0W71626PNH.....	151	RT00123SNHK.....	21	RT616DC.....	107	RT06123SNH.....	21
RT0W71626PNHEC.....	151	RT00128PNH.....	79	RT616DC.....	139	RT06123SNHEC.....	21
RT0W71626PNHK.....	151	RT00128PNHEC.....	79	RT616DC.....	155	RT06123SNHK.....	21
RT0W71626SNH.....	151	RT00128PNHK.....	79	RT616DCG.....	69	RT06128PNH.....	79
RT0W71626SNHEC.....	151	RT00128SNH.....	79	RT616DCG.....	107	RT06128PNHEC.....	79
RT0W71626SNHK.....	151	RT00128SNHEC.....	79	RT616DCG.....	139	RT06128PNHK.....	79
RT0W71832PNH.....	167	RT00128SNHK.....	79	RT616DCG.....	155	RT06128SNH.....	79
RT0W71832PNHEC.....	167	RT00142PNH.....	47	RT618DC.....	101	RT06128SNHEC.....	79
RT0W71832PNHK.....	167	RT00142PNHEC.....	47	RT618DC.....	147	RT06128SNHK.....	79
RT0W71832SNH.....	167	RT00142SNH.....	47	RT618DC.....	171	RT06142PNH.....	47
RT0W71832SNHEC.....	167	RT00142SNHEC.....	47	RT618DCG.....	101	RT06142PNHEC.....	47
RT0W71832SNHK.....	167	RT00144PNH.....	55	RT618DCG.....	147	RT06142SNH.....	47
RT010DC.....	33,41,75	RT00144PNHEC.....	55	RT618DCG.....	171	RT06142SNHEC.....	47
RT010DCG.....	33,41,75	RT00144SNH.....	55	RT620DC.....	163	RT06144PNH.....	55
RT010RL.....	33,41,75	RT00144SNHEC.....	55	RT620DCG.....	163	RT06144PNHEC.....	55
RT012DC.....	25,83,115	RT00148PNH.....	87	RT001412PNH.....	119	RT06144SNH.....	55
RT012DCG.....	25,83,115	RT00148PNHEC.....	87	RT001412PNHEC.....	119	RT06144SNHEC.....	55
RT012RL.....	25,83,115	RT00148SNH.....	87	RT001412PNHK.....	119	RT06148PNH.....	87
RT014DC.....	51,61,91, 123,131	RT00148SNHEC.....	87	RT001412SNH.....	119	RT06148PNHEC.....	87
RT014DCG.....	51,61,91, 123,131	RT00164PNH.....	63	RT001412SNHEC.....	119	RT06148SNH.....	87
RT014RL.....	51,61,91, 123,131	RT00164PNHEC.....	63	RT001412SNHK.....	119	RT06148SNHEC.....	87
RT016DC.....	69,107, 139,155	RT00164SNH.....	63	RT001619PNH.....	135	RT06164PNH.....	63
RT016DCG.....	69,107, 139,155	RT00164SNHEC.....	63	RT001619PNHEC.....	135	RT06164PNHEC.....	63
RT016RL.....	69,107,139,155	RT00169PNH.....	103	RT001619PNHK.....	135	RT06164SNH.....	63
RT018DC.....	101,147,171	RT00169PNHEC.....	103	RT001619SNH.....	135	RT06164SNHEC.....	63
RT018DCG.....	101,147,171	RT00169SNH.....	103	RT001619SNHEC.....	135	RT06188PNH.....	95
RT018RL.....	101,147,171	RT00169SNHEC.....	103	RT001619SNHK.....	135	RT06188PNHEC.....	95
RT020DC.....	163	RT00188PNH.....	95	RT001823PNH.....	143	RT06188SNH.....	95
RT020DCG.....	163	RT00188PNHEC.....	95	RT001823PNHEC.....	143	RT06188SNHEC.....	95
RT020RL.....	163	RT00188SNH.....	95	RT001823PNHK.....	143	RT07102PNH.....	37
RT00102PNH.....	37	RT00188SNHEC.....	95	RT001823SNH.....	143	RT07102PNHEC.....	37
		RT610DC.....	33	RT001823SNHEC.....	143	RT07102SNH.....	37
		RT610DC.....	41	RT001823SNHK.....	143	RT07102SNHEC.....	37
		RT610DC.....	75	RT002028PNH.....	159	RT07104PNH.....	29
		RT610DCG.....	33	RT002028PNHEC.....	159	RT07104PNHEC.....	29
		RT610DCG.....	41	RT002028PNHK.....	159	RT07104PNHK.....	29

Appendix

Part Number Index (RT0-SP)

RT07104SNH.....	29	RT061823PNHEC.....	143	RTHP0161PN-M1.....	187	SP16M1G15.....	27,35,44,53, 85,93,109,125,141, 149,165,177,202
RT07104SNHEC.....	29	RT061823PNHK.....	143	RTHP0201PNH-50C.....	191	SP16M1G30.....	27,35,44,53, 85,93,109,125,141, 149,165,177,202
RT07104SNHK.....	29	RT061823SNH.....	143	RTHP0201PNH-70C.....	191	SP20M1F.....	27,35,44,53, 85,93,109,125,141, 149,165,177,202
RT07123PNH.....	21	RT061823SNHEC.....	143	RTHP0201PNH-95C.....	191	SP20M1G5.....	27,35,44,53, 85,93,109,125,141, 149,165,177,202
RT07123PNHEC.....	21	RT061823SNHK.....	143	RTHP0201PNH-H1.....	191	SP20M1G10.....	27,35,44,53, 85,93,109,125,141, 149,165,177,202
RT07123PNHK.....	21	RT062028PNH.....	159	RTHP0201PNH-M1.....	191	SP20M1G15.....	27,35,44,53, 85,93,109,125,141, 149,165,177,202
RT07123SNH.....	21	RT062028PNHEC.....	159	RTHP0203PNH-16C.....	197	SP20W1F.....	45,77,117, 133,157,173,203
RT07123SNHEC.....	21	RT062028PNHK.....	159	RTHP6121SNH-16C.....	197	SP20W1G5.....	45,77,117, 133,157,173,203
RT07123SNHK.....	21	RT062028SNH.....	159	RTHP6121SNH-16S2.....	179	SP20W1G30.....	27,35,44,53, 85,93,109,125,141, 149,165,177,202
RT07128PNH.....	79	RT062028SNHEC.....	159	RTHP6141SNH-16S2.....	179	SP20W1G10.....	45,77,117, 133,157,173,203
RT07128PNHEC.....	79	RT062028SNHK.....	159	RTHP6141SNH25-BS2.....	183	SP20W1G15.....	45,77,117, 133,157,173,203
RT07128PNHK.....	79	RT062448PNH.....	174	RTHP6141SNH25-EC.....	183	SP24M1F.....	27,35,44,53,85, 93,109,125,141, 149,165,177,202
RT07128SNH.....	79	RT062448SNH.....	174	RTHP6141SNH25-PS2.....	183	SP24M1G5.....	27,35,44,53, 85,93,109,125, 141,149,165, 177,202
RT07128SNHEC.....	79	RT071412PNH.....	119	RTHP6141SNH25-PS3.....	183	SP24M1G10.....	27,35,44,53, 85,93,109,125, 141,149,165, 177,202
RT07128SNHK.....	79	RT071412PNHEC.....	119	RTHP6161SNH25-PS2.....	187	SP24M1G15.....	27,35,44,53, 85,93,109,125, 141,149,165, 177,202
RT07142PNH.....	47	RT071412PNHK.....	119	RTHP6161SNH35-PS2.....	187	SP24W1F.....	45,77,117, 133,157,173,203
RT07142PNHEC.....	47	RT071412SNH.....	119	RTHP6161SNH-35S2.....	187	SP24W1G5.....	45,77,117, 133,157,173,203
RT07142SNH.....	47	RT071412SNHEC.....	119	RTHP6161SNH50-PS2.....	187	SP24W1G10.....	45,77,117, 133,157,173,203
RT07142SNHEC.....	47	RT071412SNHK.....	119	RTHP6201SNH25-PS5.....	191	SP24W1G15.....	45,77,117, 133,157,173,203
RT07144PNH.....	55	RT071609PNH.....	103	RTHP6201SNH35-PS2.....	191	SP24M1G30.....	27,35,44,53,85, 93,109,125,141, 149,165,177,202
RT07144PNHEC.....	55	RT071609SNH.....	103	RTHP6201SNH50-PS2.....	191	SP24M1G5.....	27,35,44,53, 85,93,109,125, 141,149,165, 177,202
RT07144SNH.....	55	RT071619PNH.....	135	RTHP6201SNH70-PS1.....	191	SP24M1G10.....	27,35,44,53, 85,93,109,125, 141,149,165, 177,202
RT07144SNHEC.....	55	RT071619PNHEC.....	135	RTHP6201SNH70-PS2.....	191	SP24M1G15.....	27,35,44,53, 85,93,109,125, 141,149,165, 177,202
RT07148PNH.....	87	RT071619PNHK.....	135	RTHP6201SNH95-PS2.....	191	SP24W1F.....	45,77,117, 133,157,173,203
RT07148PNHEC.....	87	RT071619SNH.....	135	RTHP6203PNH-16S2.....	197	SP24W1G5.....	45,77,117, 133,157,173,203
RT07148SNH.....	87	RT071619SNHEC.....	135	RTHP6203SNH-16S2.....	197	SP24W1G10.....	45,77,117, 133,157,173,203
RT07148SNHEC.....	87	RT071619SNHK.....	135	SP12AIT.....	53,60, 100,109,202	SP24W1G15.....	45,77,117, 133,157,173,203
RT07164PNH.....	63	RT071823PNH.....	143	SP14M1F.....	27,35,44,53, 85,93,109,125,141, 149,165,177,202	SP24M1G30.....	27,35,44,53,85, 93,109,125,141, 149,165,177,202
RT07164PNHEC.....	63	RT071823PNHEC.....	143	SP14M1G5.....	27,35,44,53, 85,93,109,125,141, 149,165,177,202	SP24M1G5.....	27,35,44,53, 85,93,109,125, 141,149,165, 177,202
RT07164SNH.....	63	RT071823PNHK.....	143	SP14M1G10.....	27,35,44,53, 85,93,109,125,141, 149,165,177,202	SP24M1G10.....	27,35,44,53, 85,93,109,125, 141,149,165, 177,203
RT07164SNHEC.....	63	RT071823SNH.....	143	SP14M1G15.....	27,35,44,53, 85,93,109,125,141, 149,165,177,202	SP24M1G15.....	27,35,44,53, 85,93,109,125, 141,149,165, 177,203
RT07169PNHEC.....	103	RT071823SNHEC.....	143	SP16M1F.....	27,35,44,53, 85,93,109,125,141, 149,165,177,202	SP24M1G30.....	27,35,44,53, 85,93,109,125, 141,149,165, 177,203
RT07169SNHEC.....	103	RT071823SNHK.....	143	SP16M1G5.....	27,35,44,53, 85,93,109,125,141, 149,165,177,202	SP24M1G10.....	27,35,44,53, 85,93,109,125, 141,149,165, 177,203
RT07188PNH.....	95	RT072028PNH.....	159	SP16M1G10.....	27,35,44,53, 85,93,109,125,141, 149,165,177,202	SP24W1F.....	45,77,117, 133,157,173,203
RT07188PNHEC.....	95	RT072028PNHEC.....	159	SP16M1G15.....	27,35,44,53, 85,93,109,125,141, 149,165,177,202	SP24W1G5.....	45,77,117, 133,157,173,203
RT07188SNH.....	95	RT072028PNHK.....	159	SP14M1G30.....	27,35,44,53, 85,93,109,125,141, 149,165,177,202	SP24W1G10.....	45,77,117, 133,157,173,203
RT07188SNHEC.....	95	RT072028SNH.....	159	SP14M1G5.....	27,35,44,53, 85,93,109,125,141, 149,165,177,202	SP24W1G15.....	27,35,44,53, 85,93,109,125, 141,149,165, 177,203
RT061412PNH.....	119	RT072028SNHEC.....	159	SP16M1G30.....	27,35,44,53, 85,93,109,125,141, 149,165,177,202	SP24M1G30.....	27,35,44,53, 85,93,109,125, 141,149,165, 177,203
RT061412PNHEC.....	119	RT072028SNHK.....	159	RTFD10B.....	33,41,75	SP24M1G10.....	27,35,44,53, 85,93,109,125, 141,149,165, 177,203
RT061412PNHK.....	119	RTFD12B.....	25,83,91,115	RTFD14B.....	51,61,123,131	SP24M1G15.....	27,35,44,53, 85,93,109,125, 141,149,165, 177,203
RT061412SNH.....	119	RTFD16B.....	69,107,139,155	RTFD18B.....	101,147,171	SP24W1F.....	45,77,117, 133,157,173,203
RT061412SNHEC.....	119	RTFD20B.....	163	RTFD24B.....	174	SP24W1G5.....	45,77,117, 133,157,173,203
RT061412SNHK.....	119	RTHP0121PN-16C.....	179	RTHP0121PN-H1.....	179	SP16M1G10.....	27,35,44,53, 85,93,109,125,141, 149,165,177,202
RT061412SNHEC.....	119	RTHP0141PN-25C.....	183	RTHP0141PN-M1.....	183	SP16M1G15.....	27,35,44,53, 85,93,109,125,141, 149,165,177,202
RT061609PNH.....	103	RTHP0141PN-H1.....	183	RTHP0161PN-35C.....	187	SP16M1G30.....	27,35,44,53, 85,93,109,125,141, 149,165,177,202
RT061609PNHEC.....	103	RTHP0161PN-50C.....	187	RTHP0161PN-H1.....	187	SP16M1G5.....	27,35,44,53, 85,93,109,125,141, 149,165,177,202
RT061609SNH.....	103	RT061823PNH.....	143				
RT061609SNHEC.....	103						
RT061619PNH.....	135						
RT061619PNHEC.....	135						
RT061619PNHK.....	135						
RT061619SNH.....	135						
RT061619SNHEC.....	135						
RT061619SNHK.....	135						
RT061823PNH.....	143						

Appendix

Part Number Index (SP-SS)

SP24W1G10.....45,77,117, 133,157,173,203	SS16M1G30...27,35,44,53, 85,93,109,125, 141,149,165, 177,202	SS24W1F.....45,77,117, 133,157,173,203
SP24W1G15.....45,77,117, 133,157,173,203	SS20M1F.....27,35,44,53, 85,93,109,125, 141,149,165, 177,202	SS24W1G5.....45,77,117, 133,157,173,203
SP24W1G30.....45,77,117, 133,157,173,203	SS20M1G5...27,35,44,53, 85,93,109,125, 141,149,165, 177,202	SS24W1G10.....45,77,117, 133,157,173,203
SP28W1F.....45,77,117, 133,157,173,203	SS20M1G10...27,35,44,53, 85,93,109,125, 141,149,165, 177,202	SS24W1G30.....45,77,117, 133,157,173,203
SP28W1G5.....45,77,117, 133,157,173,203	SS20M1G15...27,35,44,53, 85,93,109,125, 141,149,165, 177,202	SS28W1F.....45,77,117, 133,157,173,203
SP28W1G10.....45,77,117, 133,157,173,203	SS20M1G30...27,35,44,53, 85,93,109,125, 141,149,165, 177,202	SS28W1G5.....45,77,117, 133,157,173,203
SP28W1G15.....45,77,117, 133,157,173,203	SS20W1F.....45,77,117, 133,157,173,203	SS28W1G10.....45
SP28W1G30.....45,77,117, 133,157,173,203	SS20W1G5.....45,77,117, 133,157,173,203	SS28W1G10.....45,77,117, 133,157,173,203
SS12A1T.....53,60,100, 109,202	SS20W1G10.....45,77,117, 133,157,173,203	SS28W1G15.....45,77,117, 133,157,173,203
SS14M1F.....27,35,44,53, 85,93,109,125, 141,149,165, 177,202	SS20W1G15.....45,77,117, 133,157,173,203	SS28W1G30.....45,77,117, 133,157,173,203
SS14M1G5.....27,35,44,53, 85,93,109,125, 141,149,165, 177,202	SS20W1G30...445,77,117, 133,157,173,203	
SS14M1G10...27,35,44,53, 85,93,109,125, 141,149,165, 177,202	SS24M1F.....27,35,44,53, 85,93,109,125, 141,149,165, 177,202	
SS14M1G15...27,35,44,53, 85,93,109,125, 141,149,165, 177,202	SS24M1G5.....27,35,44,53, 85,93,109,125, 141,149,165, 177,202	
SS14M1G30...27,35,44,53, 85,93,109,125, 141,149,165, 177,202	SS24M1G10...27,35,44,53, 85,93,109,125, 141,149,165, 177,203	
SS16M1F.....27,35,44,53, 85,93,109,125, 141,149,165, 177,202	SS24M1G15...27,35,44,53, 85,93,109,125, 141,149,165, 177,203	
SS16M1G5.....27,35,44,53, 85,93,109,125, 141,149,165, 177,202	SS24M1G30...27,35,44,53, 85,93,109,125, 141,149,165, 177,203	
SS16M1G10...27,35,44,53, 85,93,109,125, 141,149,165, 177,202		
SS16M1G15...27,35,44,53, 85,93,109,125, 141,149,165, 177,202		

www.amphenol-sine.com

USA

Amphenol Sine Systems
44724 Morley Drive
Clinton Township, MI 48036
Toll-Free: 1-800-394-7732
Fax: 1-586-465-1216
Email: csr@amphenol-sine.com
www.amphenol-sine.com

Germany

Amphenol Tuchel Industrial GmbH
August-Haeusser-Strasse 10
Heilbronn, Germany 74080
Phone: 49(0)-7131-929-0
Email: industrial@amphenol.de
www.amphenol-industrial.de

China

Amphenol Sine Systems
Building 21, 1st Liao Keng Industrial Zone,
Shi Yan Street, Bao An District
Shenzhen, China 518180
Tel: 86-755-8173-8000 ext. 8098
Fax: 86-755-8173-8180
www.amphenol-sine.com.cn

USA

Amphenol Corporation
Corporate Headquarters
358 Hall Ave
Wallingford Ct 06492
Phone: (877) 267-4366
www.amphenol.com

United Kingdom

Amphenol LIMITED
Thanet Way, Whitstable
Kent CT5 3JF, United Kingdom
Phone: 44-1-227-773200
Fax: 44-1-227-276571
www.amphenol.co.uk

India

Amphenol INTERCONNECT INDIA PVT LTD
105 Bhosari Industrial Area
Pune 411 026, India
Phone: +91 20 67360304
Fax: +91 20 67360321
www.amphenol-in.com

Mexico

Prolongacion Reforma 61-6 B2
Col. Paseo de las Lomas
C.P. 01330 Mexico DF, Mexico
Phone: 52-55-5258-9984
Fax: 52-55-5081-6890
Email: info@amphenolmexico.com
www.amphenolmexico.com

Australia

Amphenol AUSTRALIA PTY LIMITED
2 Fiveways Blvd., Keysborough
Melbourne, Victoria 3173 Australia
Phone: 613-8796-8888
Fax: 613-8796-8801
www.amphenol.com.au

Korea

Amphenol DAESHIN
558. Songnae-2 Dong. SoSa-Gu
Bucheon City, Gyeonggi-do,
Korea 422-818
Phone: 81-32-610-3800
Fax: 81-32-673-2507
Email: info@amphenol.co.kr
www.amphenol.co.kr

Argentina

Amphenol ARGENTINA
Avenida Callao 930
2nd floor Office B Plaza
C1023AAP Buenos Aires, Argentina
Phone: 54-11-4815-6886
Fax: 54-11-4814-5779
Email: info@amphenol.com.ar
amphenol.com.ar

Turkey

Amphenol International Ltd Turkey
Sun Plaza Kat. 15
Maslak Mah. Bilim Sok. No. 5
34398 Sisli / Istanbul – Turkey
Tel: + 90 212 367.92.20
Fax: + 90 212 367.92.21
www.amphenol.com.tr

Japan

Amphenol JAPAN
471-1, Deba, Ritto-city
shiga 520-3041, Japan
Phone: 81-77-553-8501
Fax: 81-77-551-2200
www.amphenol.co.jp

Brazil

Amphenol do Brasil Ltda
Rua Diogo Moreira, 132
20 Andar, Rooms 2001-2-3
CEP 05423-101
Sao Paulo- SP, Brazil
Phone: 55-11-3815-1003
Fax: 55-11-3815-1629
www.amphenol.com.br

South Africa

Amphenol International Ltd
South Africa
30 Impala Road
2196 Sandton, Chislehurst
South Africa
Phone: 27-11-783-9517
Fax: 27-11-783-9519
Email: sales@amphenolafrica.com
www.amphenol.com.za

Russia

Amphenol RUSSIA
8 Yaroslavskaja Street
129164 Moscow, Russia
Phone: 7495-937-6341
Fax: 7495-937-6319
www.amphenol.ru

France

Amphenol SOCAPEX
948, Promenade de l'Arve - BP 29
74311 Thyez CEDEX, France
Phone: 33(0)4-50-89-28-40
Fax: 33(0)4-50-96-29-75
www.amphenol-socapex.com

X-ON Electronics

Largest Supplier of Electrical and Electronic Components

Click to view similar products for [Circular MIL Spec Backshells](#) category:

Click to view products by [Amphenol](#) manufacturer:

Other Similar products are found below :

[5M2920-3CW](#) [60-036152-022](#) [610HS012M15](#) [M28840/504WA](#) [M28840/805WB](#) [M28840/809WA](#) [M28840/815WA](#) [M28840/816WA](#)
[627AS017M14](#) [627MA124M14S](#) [655HS002NF11](#) [CW3899-000](#) [M85049/10-134S](#) [M85049/10-17S](#) [M85049/10-33S](#) [M85049/10-94W](#)
[M85049/11-28N](#) [M85049/11-37N](#) [M85049/11-53N](#) [M85049/11-63N](#) [M85049/120-14W](#) [M85049/124-23W](#) [M85049/1720N04B](#)
[M85049/1821W05C](#) [M85049/1825W06C](#) [M85049/1919N05](#) [M85049/23-74W](#) [M85049/24-71N](#) [M85049/25-47N](#) [M85049/25-94W](#)
[M85049/27S12N](#) [M85049/39-11S](#) [M85049/39-17S](#) [M85049/39-9S](#) [M85049/6-10B](#) [M85049/6-19N](#) [M85049/6-20B](#) [M85049/77-20W04](#)
[M85049/78-11N03](#) [M85049/78-15W02](#) [M85049/78-17N04](#) [M85049/78-19N05](#) [M85049/79-19N07](#) [M85049/79-25N04](#) [M85049/82-18N02](#)
[M85049/82-22P02](#) [M85049/83-10W03](#) [M85049/84-20N03](#) [M85049/8-48N](#) [M85049/85-24N01](#)