

Multiport Contacts



Multiport Contacts

Multiport Contacts

SV Microwave is a world leader in the design and manufacture of RF/MW connectors and components. System design and platform needs have required smaller packaging with RF, D/C signal and power all in close proximity. Our proven designs and blindmate technology have enabled the integration of multiport RF signals into single housings for gang mating capability. Various existing form factors such as D38999, ARINC, Micro-D and D-Sub have provided standard components and familiar shell sizes. Hybrid technology fuses RF and D/C contacts into a single connector simplifying design and installation while eliminating discrete wiring.

BMZ Interface Specifications

Materials and Finish

Body	Stainless steel per AMS-5640, UNS-S30300, Type 1, Gold per ASTM B 488 over Nickel per SAE AMS-QQ-N-290, Class 1 or passivated
Contact	Beryllium Copper per ASTM B 195, Gold per ASTM B 488 over Nickel per SAE AMS-QQ-N-290, Class 1
Insulator	PTFE per ASTM D 1710

Electricals (Mated Pair - RG 405 Semi-Rigid Cable)

Impedance	50 Ω	Contact Resistance (Max.)	
Frequency Range	DC – 40 GHz	center conductor:	6.0 m Ω
VSWR	1.07+.01 (freq. GHz)	outer conductor:	3.0 m Ω
Insertion Loss	0.06 $\sqrt{}$ (freq. GHz)	outer to cable:	0.5 m Ω
Insulation Resistance (Min.)	10,000M Ω	DWV	1,000 VRMS
RF Leakage	-(80-freq. GHz)	Corona Extinction Voltage	250 VRMS
		RF High Potential Voltage	500 VRMS

BMA Interface Specifications

Materials and Finish

Body	Stainless steel per AMS-5640, UNS-S30300, Type 1. Brass is also available. Gold per ASTM B 488 over Nickel per SAE AMS-QQ-N-290, Class 1 or passivated
Contact	Beryllium Copper per ASTM B 196, Gold per ASTM B 488 over Nickel per SAE AMS-QQ-N-290, Class 1
Insulator	PTFE per ASTM D 1710
Design	Interface dimensions per MIL-STD-348

Electricals (Mated Pair - RG 405 Semi-Rigid Cable)

Frequency	DC to 22 GHz (DC to 26.5 GHz available for semi-rigid cable and receptacles)
Nominal Impedance	50 Ω
VSWR	
DC to 18 GHz	1.05 + .005f (GHz)
18 to 22 GHz	1.05 + .009f (GHz)

BMA Interface Specifications (continued)

Electricals (continued)

Insertion Loss	.03x√f (GHz)
Insulation Resistance	5,000 Megohms Max.
Contact Resistance	
Center Contact	2.0 Milliohms Max.
Outer Contact	2.0 Milliohms Max.
Dielectric Withstanding Voltage	1,000 Volts RMS
Corona Extinction Voltage at 70,000 Ft.	335 Volts Min.
RF High Potential at 5 MHz	670 Volts RMS
RF Leakage	-(90-fGHz) dB Min.
Interface Only	(fully mated)

SMPM Interface Specifications

Materials and Finish

Female Bullet Adapter	Beryllium Copper per ASTM B196, Copper Alloy UNS C17300, Temper TD04, Gold per ASTM B 488, Type II, Code C, Class 1.27 over Nickel per AMS-QQ-N-290 Class 1
Shroud (Hermetically Sealed with Corning® 7070 Glass)	Kovar® per ASTM-F15, Stainless Steel per AMS 5640, Alloy UNS S30300, Free Machining Type 303, Condition A, Passivated per AMS-QQ-P-35, Type II, Gold per ASTM B 488, Type II, Code C, Class 1.27 over Nickel per AMS-QQ-N-290 Class 1
Shroud Non-Hermetic	Stainless per AMS 5640, Alloy UNS S30300, Free Machining Type 303, Condition A, Passivated per AMS-QQ-P-35, Type II, Gold per ASTM B488, Type II, Code C, Class 1.27 over Nickel per AMS-QQ-N-290 Class 1
Center Contact (Socket)	Beryllium Copper per ASTM B196, Copper Alloy UNS C17300, Temper TD04, Gold per ASTM B488, Type II, Code C, Class 1.27 over Nickel per AMS-QQ-N-290 Class 1
Insulator	Teflon per ASTM D1710 Ultem® 1000 (polyetherimide) per ASTM 5205 Torlon® (polyamide-Imide) per ASTM 5204

Electricals (Mated Pair - RG 405 Semi-Rigid Cable)

Frequency Range	DC to 65 GHz
Nominal Impedance	50 Ω
VSWR	1.1:1 DC to 26.5 GHz (typical) 1.3:1 26.5 to 65 GHz (typical)
Insertion Loss (Adapters)	.10 dB x √f (where f = GHz) dB
Insertion Loss (Cable Connectors)	.12 dB x √f (where f = GHz) dB
RF Leakage (Fully Mated)	-80 dB from DC to 3 GHz; -65 dB from 3 to 65 GHz
Temperature Rating	-65°C to +165°C
Dielectric Withstanding Voltage	325 VRMS min. at sea level
Insulation Resistance	5,000 megohms min.
Center Contact (Socket) Resistance	6.0 milliohms max.
Outer Contact Resistance	2.0 milliohms max.

Coax High Frequency D38999 and ARINC Contacts

Size 8, 50 Ohm, Sockets

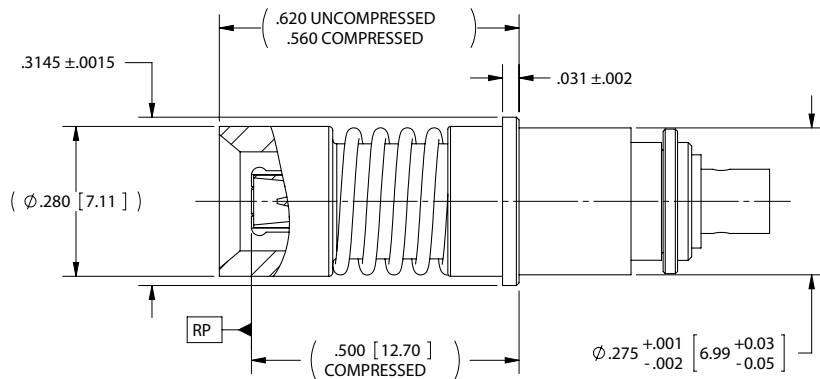

Cable	Max. Freq.	P/N	Interface
RG-142/400	12 GHz	SF9811-6002	BMZ
.085 SR	18 GHz	SF9811-6000	BMZ
.141 SR	18 GHz	SF9811-6001	BMZ
.085 SR	26.5 GHz	SF9411-6000	BMA
.141 SR	26.5 GHz	SF9411-6001	BMA
.085 SR	40 GHz	SF9911-6000	BMZ (mod)

Size 8, 50 Ohm, Pins

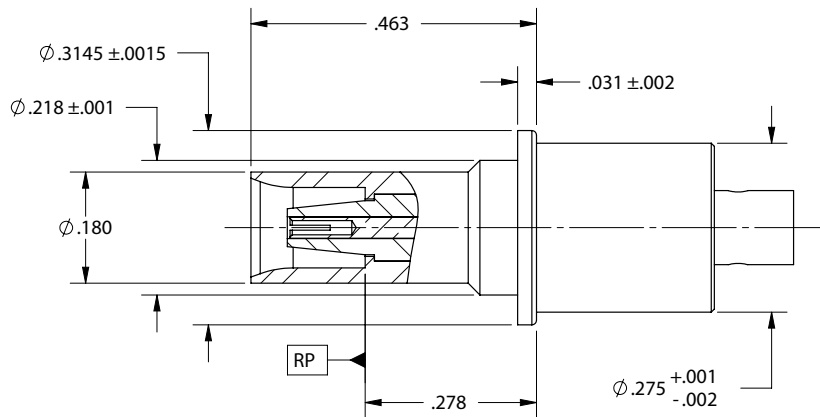

Cable	Max. Freq.	P/N	Interface
RG-142/400	12 GHz	SF9821-6002	BMZ
.085 SR	18 GHz	SF9821-6000	BMZ
.141 SR	18 GHz	SF9821-6001	BMZ
.085 SR	26.5 GHz	SF9421-6000	BMA
.141 SR	26.5 GHz	SF9421-6001	BMA
.085 SR	40 GHz	SF9921-6000	BMZ (mod)

Coax High Frequency D38999 and ARINC Contacts

Size 8, 75 Ohm, Sockets

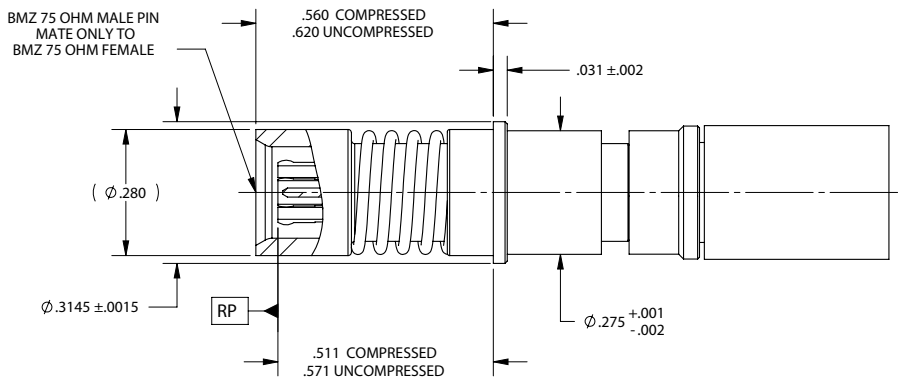

Cable	Max. Freq.	P/N
LMR 240-75	2 GHz	SF9811-60003
RG-179	2 GHz	SF9811-60005

Size 8, 75 Ohm, Pins

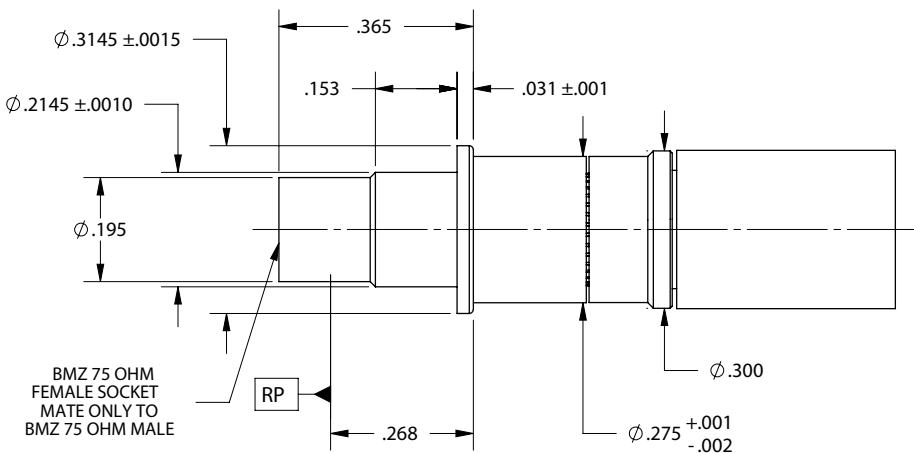

Cable	Max. Freq.	P/N
LMR 240-75	2 GHz	SF9821-60003
RG-179	2 GHz	SF9321-60007

Coax High Frequency D38999, ARINC and HDB3 Contacts

Size 12, 50 Ohm, Sockets

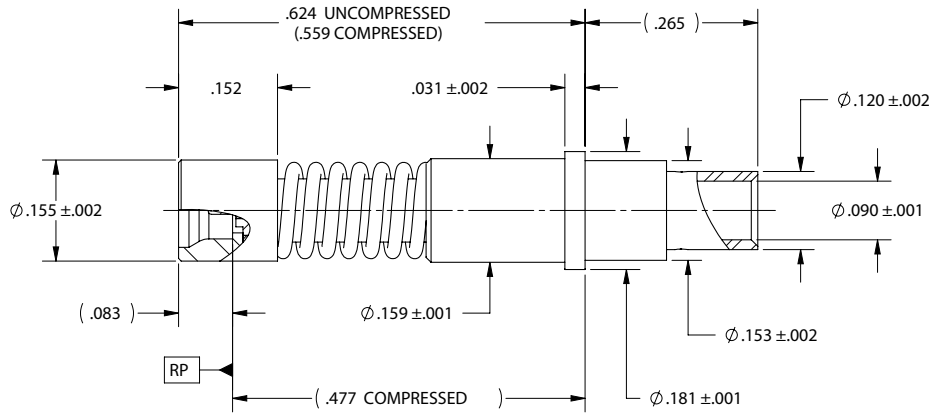

Cable	Max. Freq.	P/N
.085 SR	65 GHz	SF3211-6004

Size 12, 50 Ohm, Pins

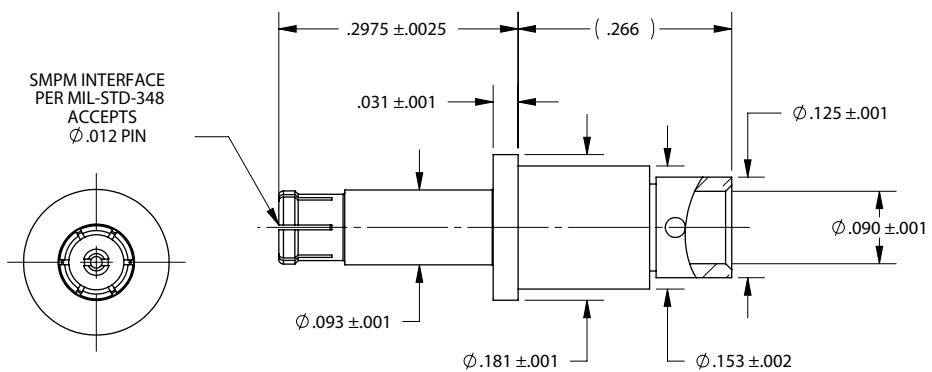

Cable	Max. Freq.	P/N
.085 SR	65 GHz	3221-4002

Coax High Frequency D38999 and ARINC Contacts

Size 16, 50 Ohm, Sockets

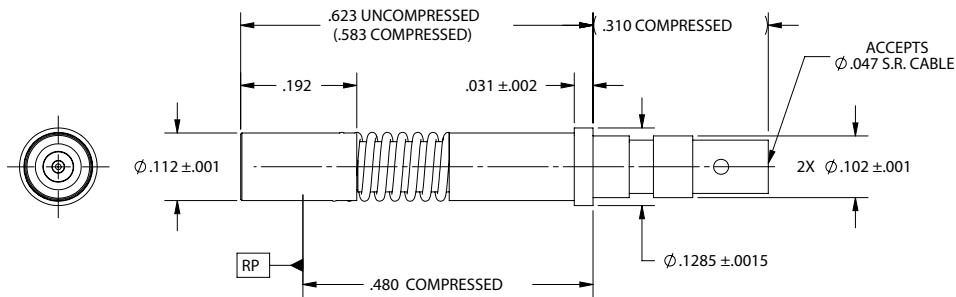

Cable	Max. Freq.	P/N
.047 SR	110 GHz	SF9911-60001

Size 16, 50 Ohm, Pins

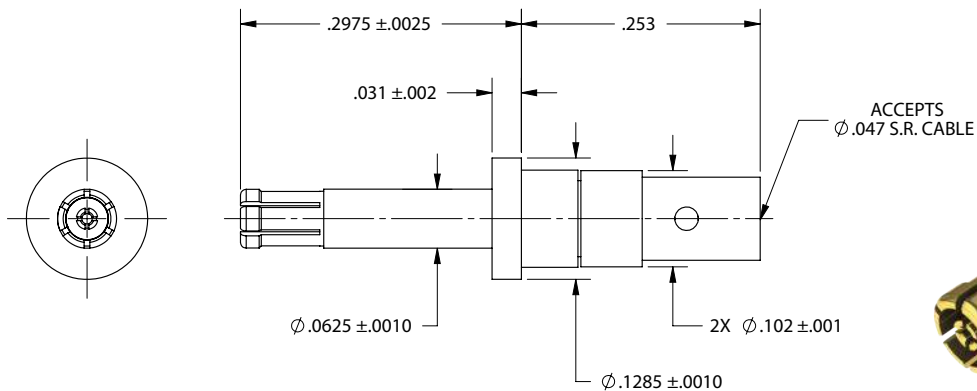

Cable	Max. Freq.	P/N
.047 SR	110 GHz	9921-40001

Amphenol LRM Contacts

Size 12, 50 Ohm, Sockets

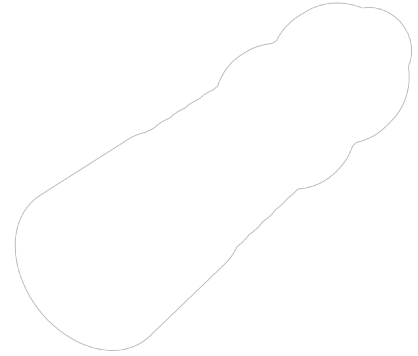
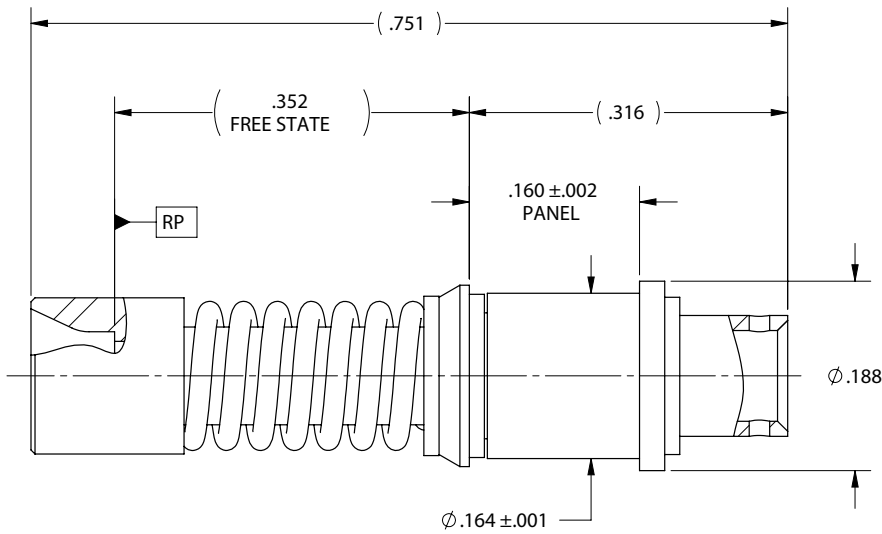

Cable	Max. Freq.	P/N
.085	65 GHz	SF3211-60018

Size 12, 50 Ohm, Pins

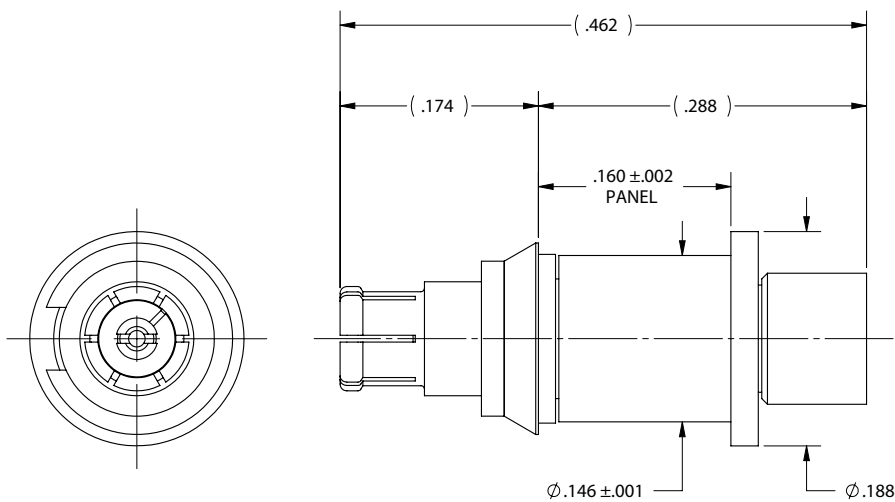

Cable	Max. Freq.	P/N
.085	65 GHz	3221-40010

Amphenol SIM Size 12 Contacts

Size 12, 50 Ohm, Sockets

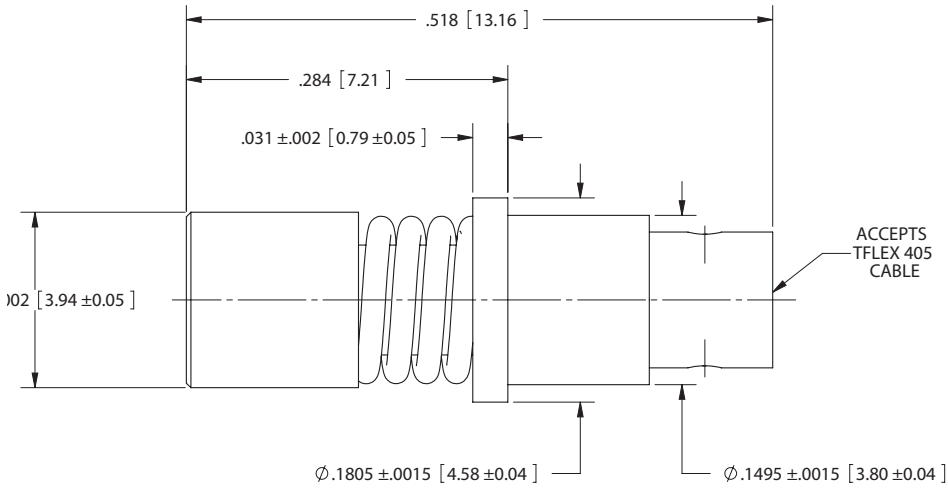

Cable	Max. Freq.	P/N
T-Flex 405	65 GHz	SF9351-60004

Size 12, 50 Ohm, Pins

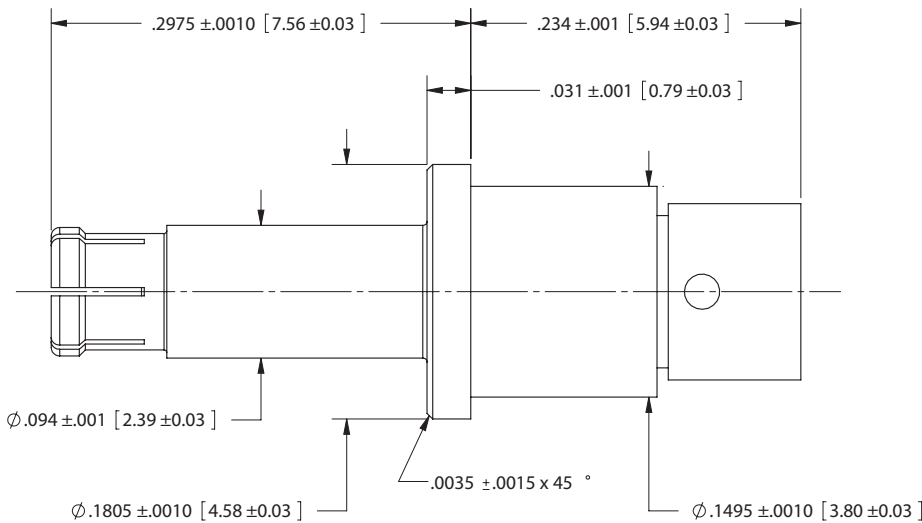

Cable	Max. Freq.	P/N
T-Flex 405	65 GHz	SF9341-40003

Standard M39029 Size 8 Contacts

Size 8, 50 Ohm, Sockets

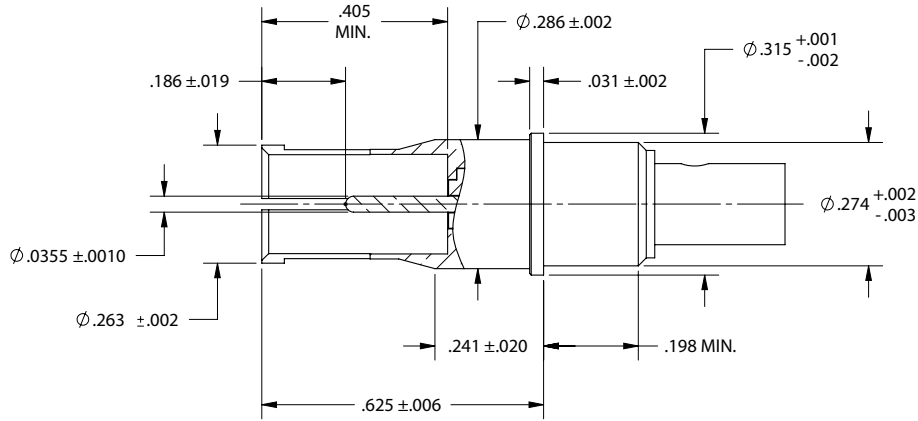

Cable	Max. Freq.	P/N
.085	3 GHz	8001-4108
.141	3 GHz	8001-4103

Size 8, 50 Ohm, Pins

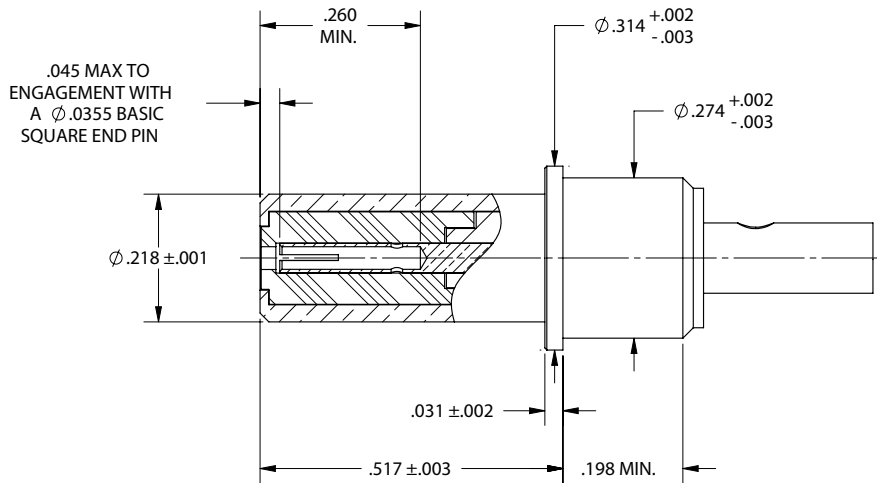

Cable	Max. Freq.	P/N
.085	3 GHz	8001-4107
.141	3 GHz	8001-4101

Standard M39029 Size 12 Contacts

Size 12, 50 Ohm, Sockets

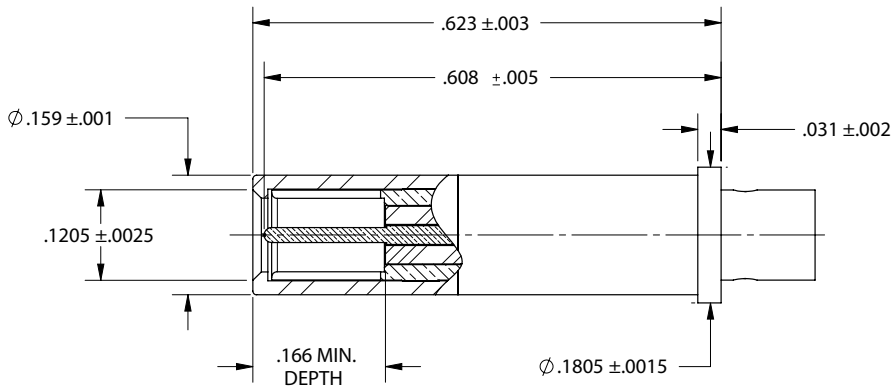

Cable	Max. Freq.	P/N
.085	3 GHz	8001-4104
.141	3 GHz	8001-4105

Size 12, 50 Ohm, Pins

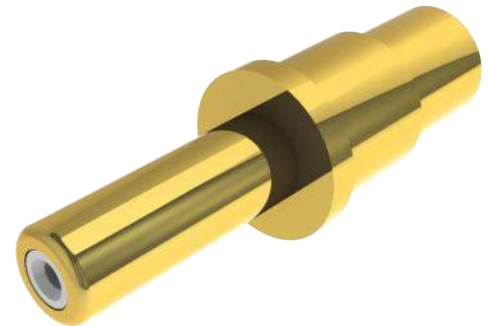
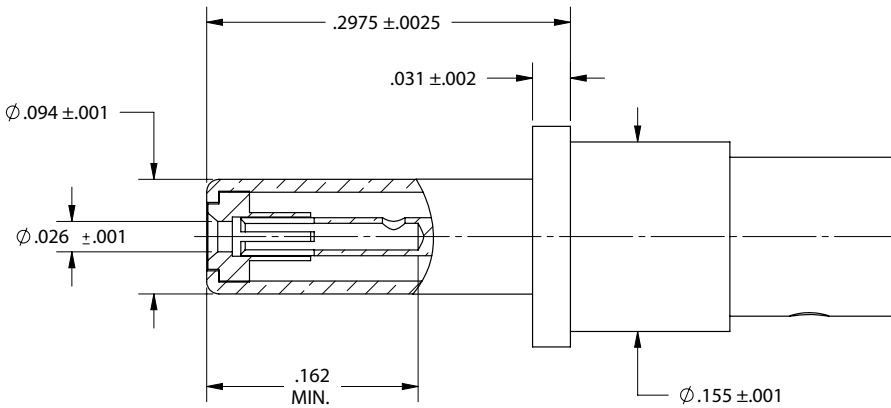

Cable	Max. Freq.	P/N
.085	3 GHz	8001-4102
.141	3 GHz	8001-4106

Size 8 Triax Contacts for D38999

Size 8, Sockets

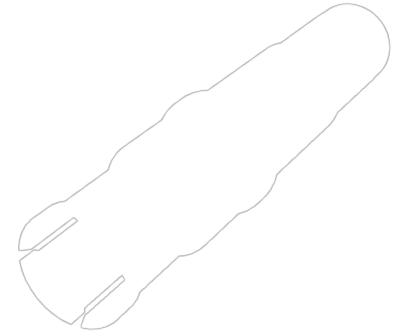
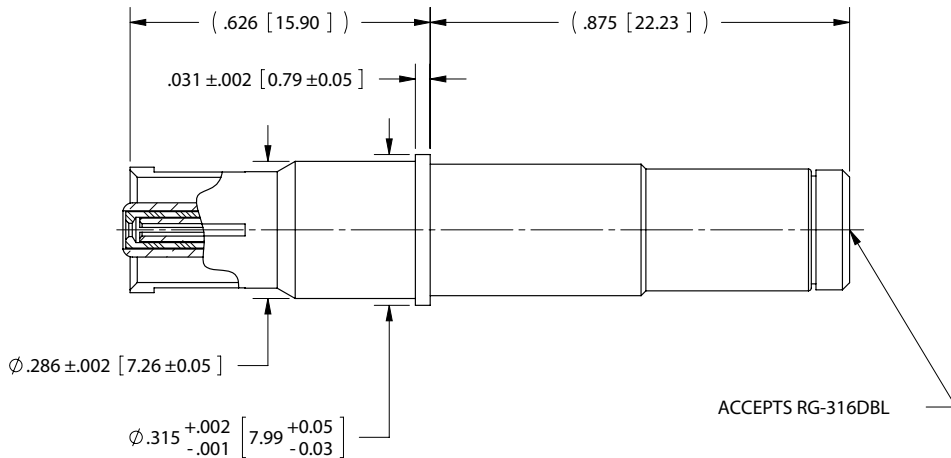

Cable	P/N
RG-316DBL	9311-60006

Size 8, Pins

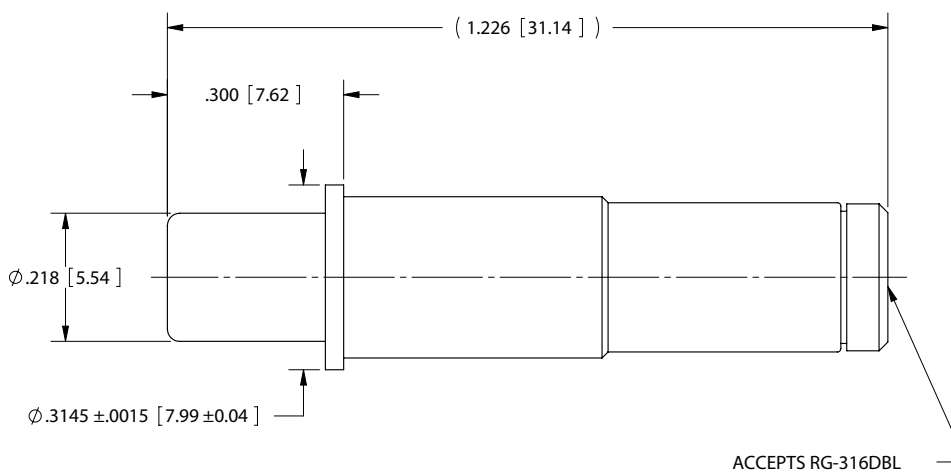

Cable	P/N
RG-316DBL	9321-60008

Size 12 Triax Contacts for D38999

Size 12, Sockets

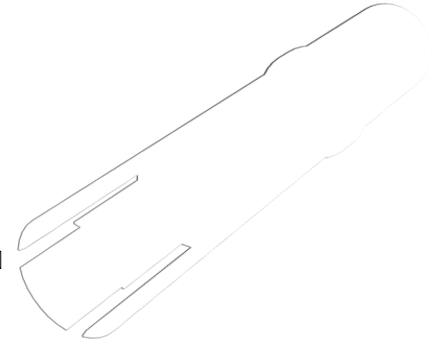
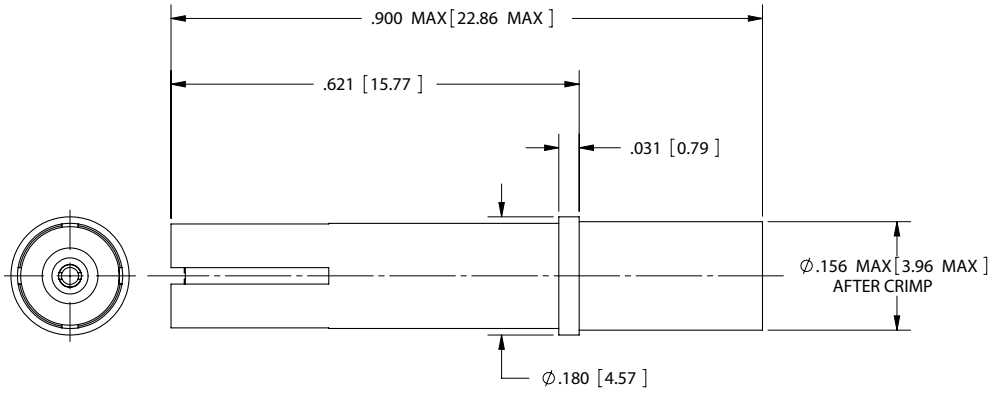

Cable	P/N
RG-403	9351-40001

Size 12, Pins

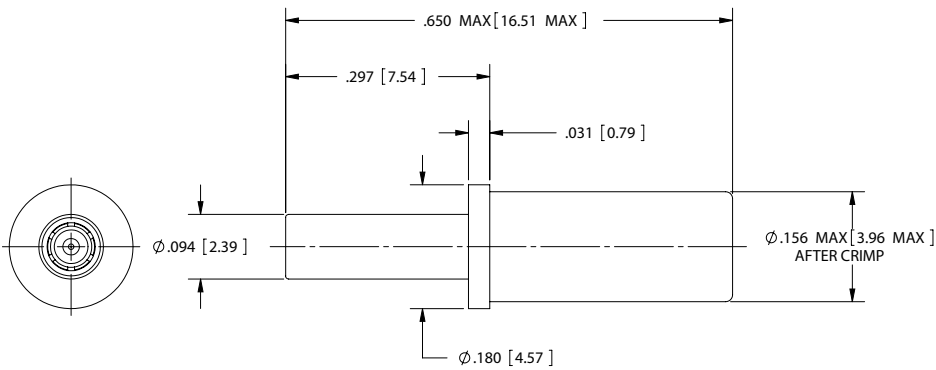

Cable	P/N
RG-403	9341-00004

Micro D Contacts

Micro D, 50 Ohm, Sockets

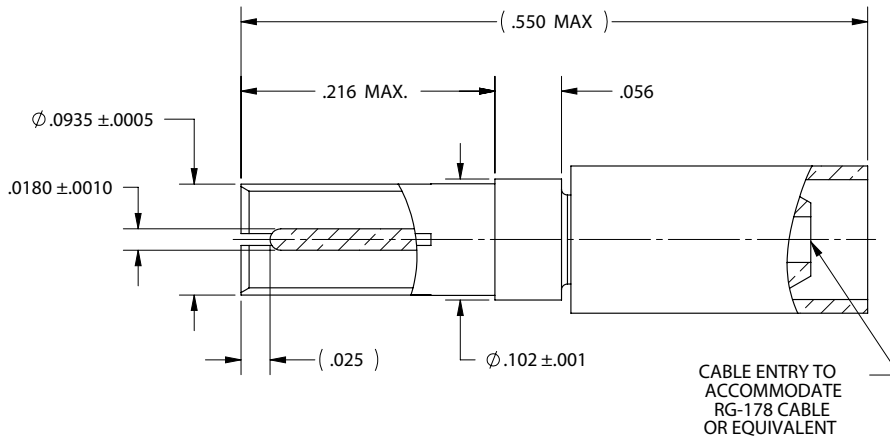

Termination	Max. Freq.	P/N
RG-178	10 GHz	8011-4001

Micro D, 50 Ohm, Pins

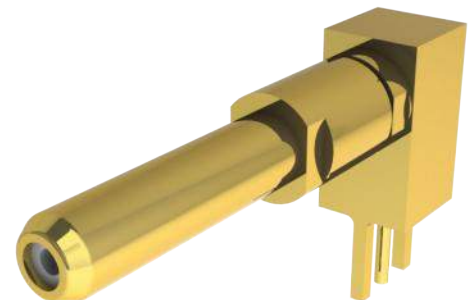
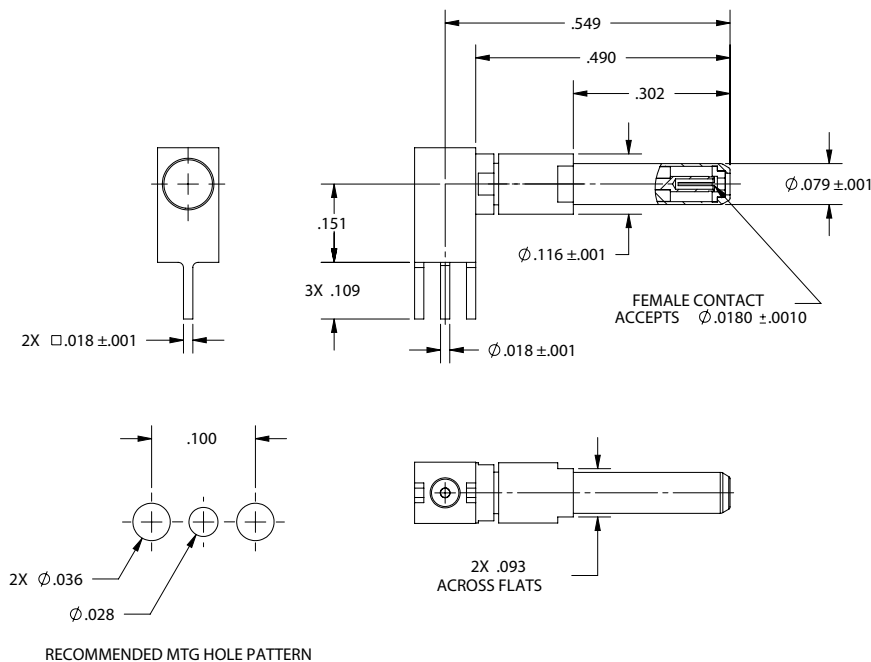

Termination	Max. Freq.	P/N
R/A, PC Mount	10 GHz	8022-0005

Custom Multiports

8 Port Edge Mount SMPM

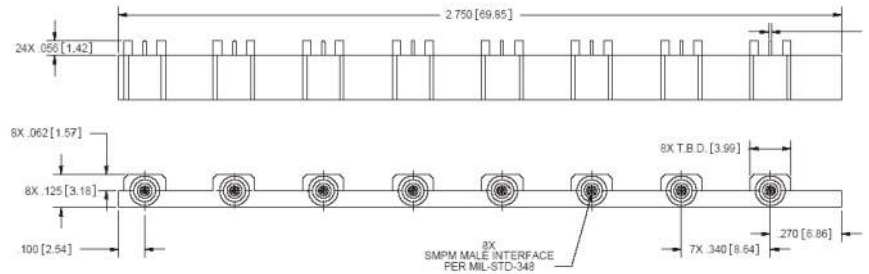
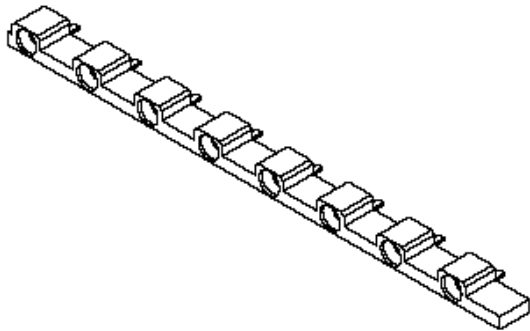

Hybrid RF and D/C Multiport Blocks

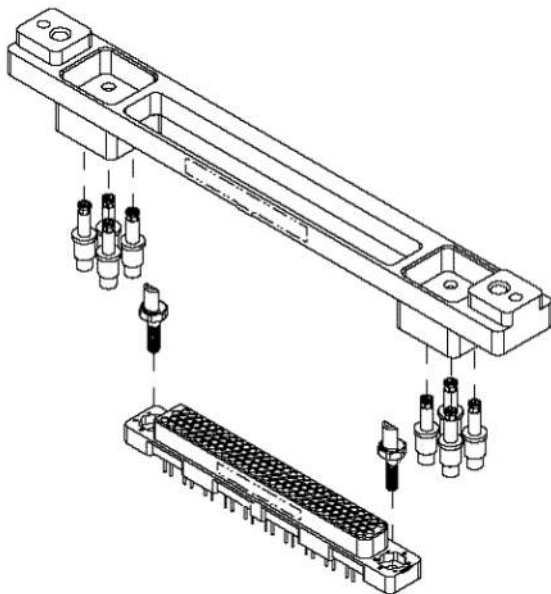

X-ON Electronics

Largest Supplier of Electrical and Electronic Components

Click to view similar products for [RF Connectors / Coaxial Connectors](#) category:

Click to view products by [Amphenol](#) manufacturer:

Other Similar products are found below :

[8915-1511-000](#) [89674-0827](#) [6001-7071-019](#) [6002-7051-003](#) [6059674-1](#) [619550-1](#) [630059-000](#) [M39030/3-01N](#) [6500-7071-046](#) [6769](#)
[CX050L2AQ](#) [7002-1541-010](#) [7002-1542-011](#) [7002-1572-002](#) [7003-1542-011](#) [7004-1512-000](#) [7009-1511-004](#) [7010-1511-000](#) [7029-1511-](#)
[060](#) [7101-1541-010](#) [7101-1571-002](#) [7145-1521-002](#) [7203-1571-003](#) [7209-1511-011](#) [7210-1511-015](#) [7210-1511-019](#) [73137-5015](#) [73216-](#)
[2241](#) [73404-2300](#) [7405-1521-005](#) [7405-1521-802](#) [8527](#) [8547](#) [FS11V](#) [9049-9513-000](#) [9074-9513-000](#) [9101-9573-002](#) [910A205F](#) [9130-](#)
[9573-002](#) [PL11SC-026](#) [PL375-33](#) [PL40-5](#) [PL74C-221](#) [PL75MC-217](#) [PL803-7](#) [980-8666-005](#) [1200690078](#) [1-201144-1](#) [R107003010W](#)
[R110A172100](#)