

| TABLE 1 | | | |
|-------------|------------|----------------------|--------------------------|
| AHSP P/N | LENGTH "A" | ACD P/N | DESCRIPTION |
| NDVVYF-C101 | 1000±20MM | SF-NDVVYF0001-001M | OSFP 30AWG PASSIVE, 1M |
| NDVVYF-C102 | 2000±40MM | TBD | TBD |
| NDVVYF-C104 | 1500±20MM | SF-NDVVYF0004-001.5M | OSFP 30AWG PASSIVE, 1.5M |

| REVISIONS | | | | | | |
|-----------|------|---------------|--|--------|------------|-----------|
| ZONE | REV. | ECN | DESCRIPTION | BY | DATE | APPROVED |
| ALL | A | MKHN-18121403 | NEW RELEASE | HCL-PB | 12/26/2018 | M.HUSSAIN |
| | B | RGAO-20121603 | ADDED ACD P/N COLUMN TO TABLE 1. ADDED CE STAMP TO SHEET 1. ADDED REFERENCE DIMENSION TO BENDING RADIUS. | N.ZENG | 12/16/2020 | Y.CHEN |
| | C | RGAO-21020301 | ADDED DESCRIPTION COLUMN TO TABLE 1. | N.ZENG | 2/4/2021 | Y.CHEN |

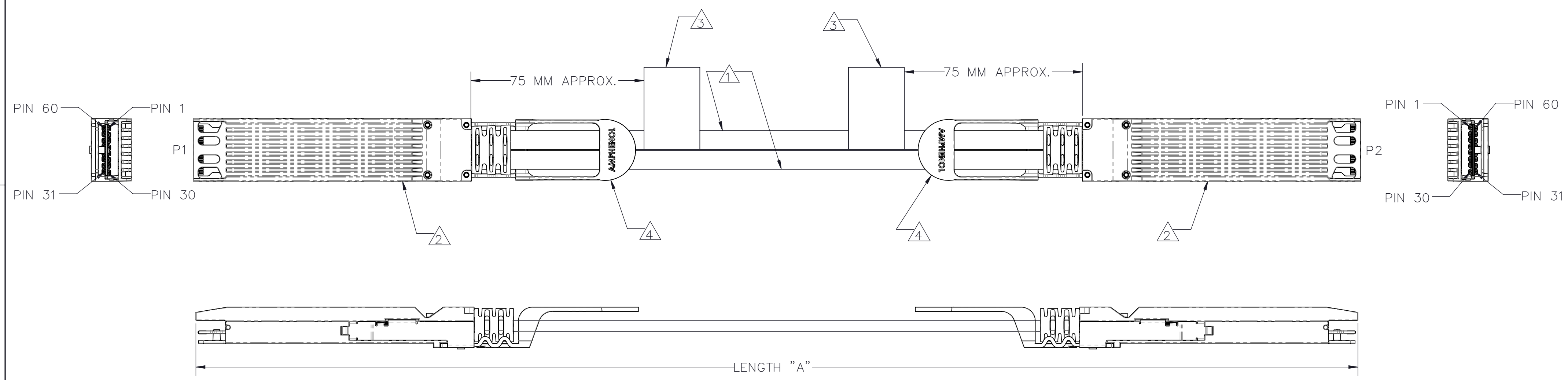

| TABLE 2 | |
|----------|---|
| ITEM No. | DESCRIPTION |
| 1 | 30 AWG, 8-PR, PVC JKT, AWM STYLE 20276 80°C, VM1 |
| 2 | PLUG, OSFP, REFERENCE "OSFP MSA" |
| 3 | LABEL, FLAGGED-AHSP PN, SN, LENGTH |
| 4 | PULL TAB, BLUE 2718 |
| 5 | EPROM - REFERENCE OSFP MSA & SFF-8636, PAGE A0 ONLY |

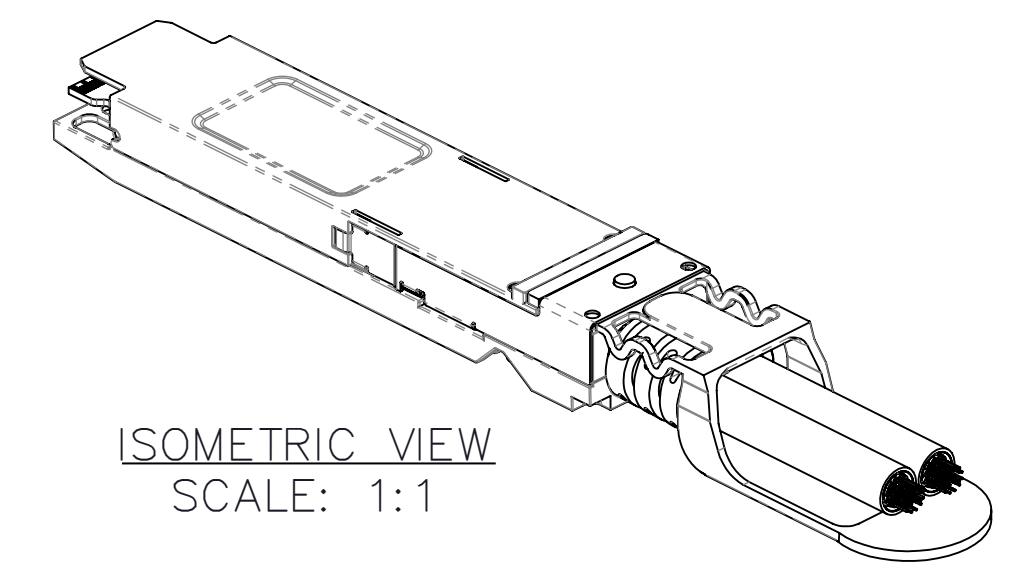
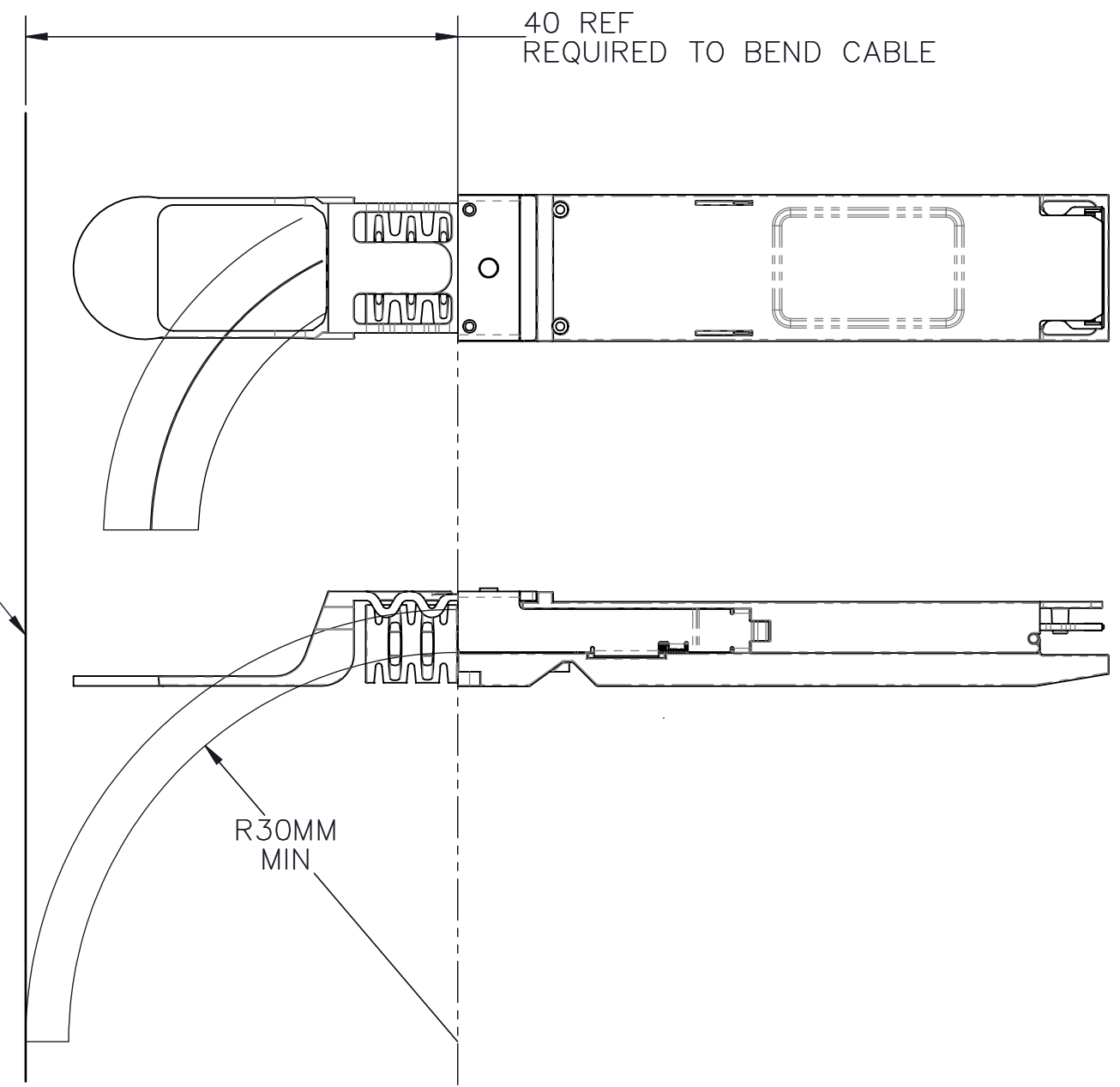

- NOTES:
- THIS DRAWING IS RESERVED FOR AMPHENOL CABLES ON DEMAND.
 - ASSEMBLIES SHALL BE COMPLIANT TO OSFP MSA SPECIFICATION.
 - CABLE ASSEMBLIES, COMPONENTS AND SUB-COMPONENTS SHALL BE COMPLIANT TO EU DIRECTIVE 2011/65/EU-RoHS2.
 - CABLE ASSEMBLIES MUST MEET SHIELDING EFFECTIVENESS REQUIREMENTS OF 35DB MINIMUM FROM 1-10GHZ AND 30DB FROM 10-18 GHZ.
 - EPROM CONTENT SHALL BE COMPLIANT WITH OSFP MSA & SFF-8636 SPECIFICATIONS FOR 100GBASE-CR-4. EPROM REVISION IS EQUAL TO CUSTOMER PART NUMBER REVISION UNLESS OTHERWISE NOTED.
 - PACKAGE COMPLETED ASSY IN AN APPROPRIATELY SIZED ESD BAG.
 - UL LABEL MUST BE ON SHIPPING CARTON PER SUBJECT 764 OF THE UL COMPONENT WIRING HARNESS (ZPFW2) FILE #E86140. CSA LABEL MUST BE ON SHIPPING CARTON.

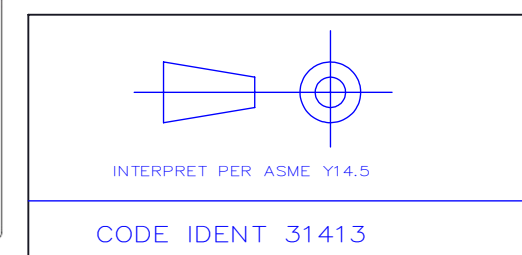
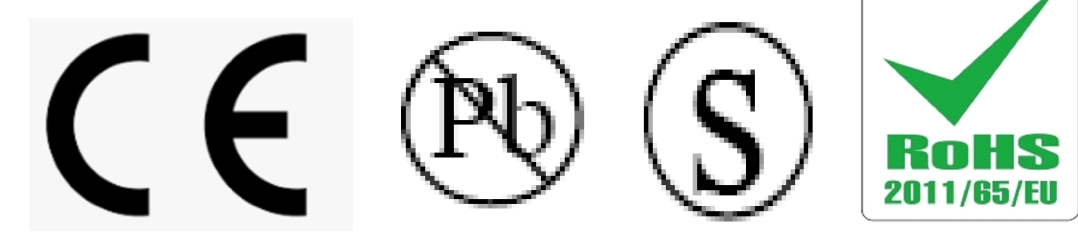

| | | | |
|---|-----------------|---|--|
| TOLERANCES | DWN 12/14/2018 | <p>Amphenol AHSP</p> <p>A Division of Amphenol Corporation</p> <p>200 Innovative Way, Suite 201, Nashua, N.H. 03062 (603) 879-3000</p> | TITLE |
| 0.0 ± 0.1 | M.HUSSAIN | | CABLE ASSY, OSFP PASSIVE, 100Ω, 30 AWG |
| 0.00 ± 0.08 | CHK 12/14/2018 | | PART NO. |
| 0.000 ± - | M.HUSSAIN | | SEE TABLE 1 |
| ANGLES ± 1.0° | APVD 12/14/2018 | | DRAWING NO. |
| UNLESS OTHERWISE SPECIFIED DIMENSIONS ARE IN MM | | | C-NDVVYF-C199 |
| CUSTOMER USE DRAWING | | | SIZE D SCALE 2:1 SHEET 1 of 2 |

| REVISIONS | | | | | | |
|-----------|------|-----|-------------|----|------|----------|
| ZONE | REV. | ECN | DESCRIPTION | BY | DATE | APPROVED |
| | | | SEE SHEET 1 | | | |

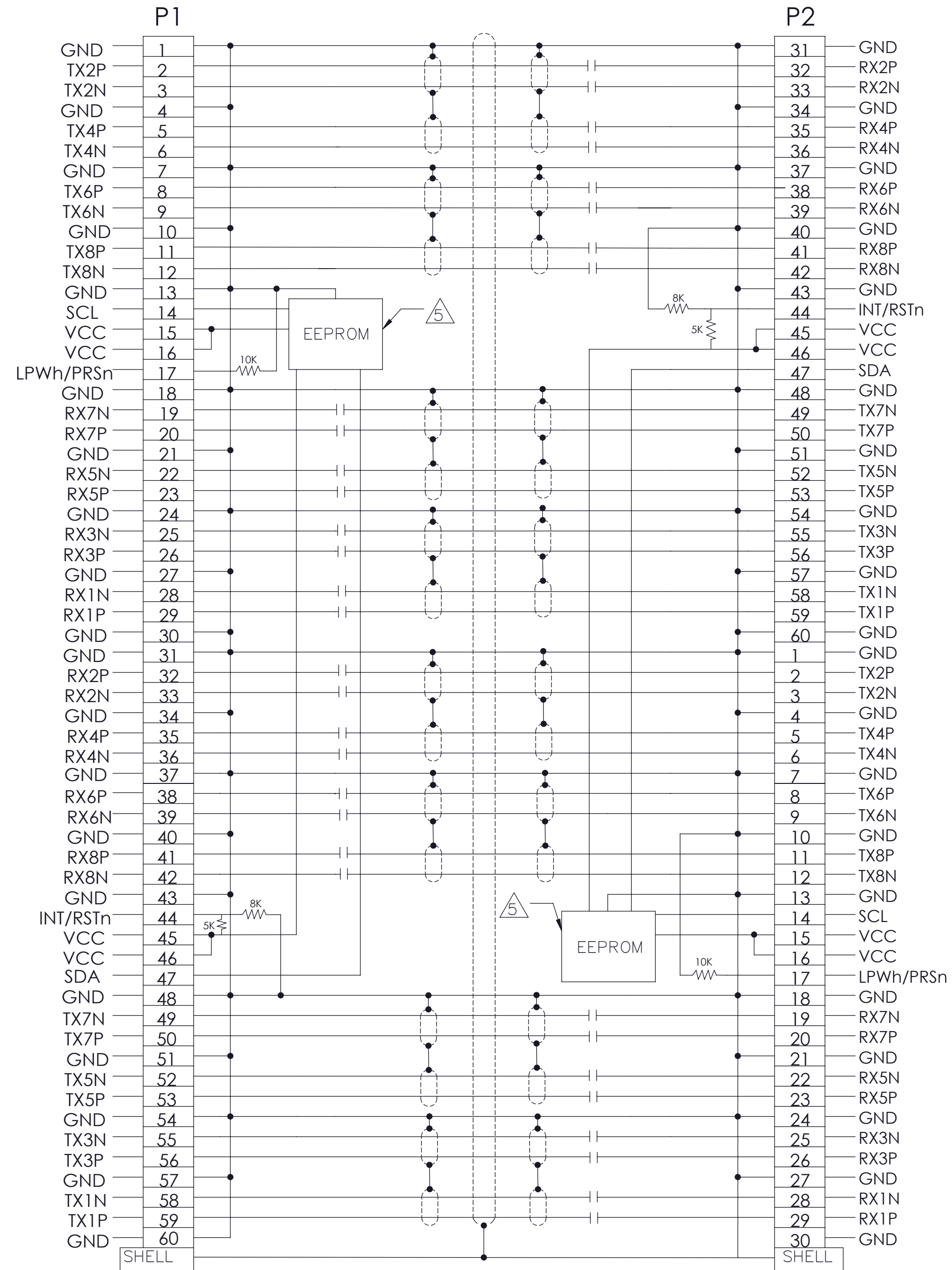

NOTE: DC BLOCKING CAP VALUE IS 100nF

| | | | | |
|---|--------|-------|------------|--|
| TOLERANCES | | DWN | 12/14/2018 | Amphenol AHSP A Division of Amphenol Corporation 200 Innovative Way, Suite 201, Nashua, N.H. 03062 (603) 879-3000 |
| 0.0 | ± 0.1 | CHK | 12/14/2018 | |
| 0.00 | ± 0.08 | | M.HUSSAIN | |
| 0.000 | ± - | APVD | 12/14/2018 | |
| ANGLES | | | M.HUSSAIN | TITLE CABLE ASSY, QSFP PASSIVE, 100Ω, 30 AWG |
| UNLESS OTHERWISE SPECIFIED DIMENSIONS ARE IN MM | | | | |
| CUSTOMER USE DRAWING | | | | PART NO. SEE TABLE 1 REV N/A |
| DRAWING NO. C-NDVVYF-C199 | | | | REV C |
| SIZE | D | SCALE | 1:1 | SHEET 2 of 2 |

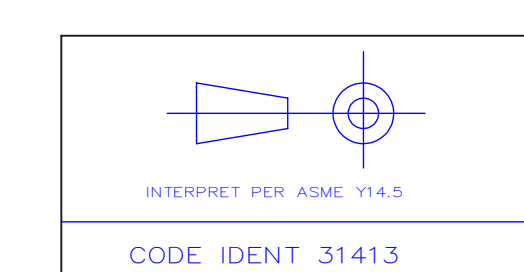

X-ON Electronics

Largest Supplier of Electrical and Electronic Components

Click to view similar products for [Ethernet Cables / Networking Cables](#) category:

Click to view products by [Amphenol](#) manufacturer:

Other Similar products are found below :

[73-6670-7](#) [73-6680-15](#) [73-7797-25](#) [MCJB2-10P6Q7-120](#) [84909-0204](#) [1200700174](#) [1200860368](#) [E16A06002M030](#) [E200102-009-S1](#)
[AX105346-EW](#) [MT14-187L](#) [17-103530](#) [ERWPAB3002M005](#) [190-038045-01](#) [NK5EPC18RDY](#) [NK5EPC18VLY](#) [NK5EPC18YLY](#)
[NK5EPC1GRY](#) [NK5EPC4Y](#) [NK5EPC6YLY](#) [NK5EPC8BLY](#) [NK5EPC9YLY](#) [1969343-6](#) [C501100010](#) [C501106002](#) [C501106007](#)
[C501106015](#) [C501106025](#) [C601102010](#) [C601104010](#) [C601106007](#) [C601106015](#) [2142758-2](#) [2168427-2](#) [CAT1106007](#) [21949-1](#) [2J1866A](#)
[RJF SFTP 5E 0500](#) [AX100351](#) [MN14CEC/ST](#) [C501100015](#) [C501106004](#) [C501106010](#) [C5F1108007](#) [C601104004](#) [C601106004](#)
[CA21106004](#) [CA21106010](#) [CA21106015](#) [CA21109007](#)