

AMPHENOL PART NUMBER CONFIGURATION

U95-Z105-XXX1-3X1

CAGE & CONNECTOR CONTACT PLATING

4 = 0.76 µm MIN. GOLD OVER 1.27-3.81 µm OF NICKEL ON MATING AREA
 0.381-1.52 µm OF MATTE TIN OVER 1.27-3.81 µm OF NICKEL ON PRESS FIT TAIL AREA.
 Ni PLATING FOR CAGE
 (RoHS COMPLIANT PER RoHS DIRECTIVE 2011/65/EU)

OPTIONAL DUST COVER

0 = WITHOUT DUST COVER
 D = WITH DUST COVER

VENT HOLES AND EMI COVER

0 = WITH LARGE VENT HOLES & WITH EMI COVER
 2 = WITH SMALL VENT HOLES & WITH EMI COVER
 4 = WITH RECTANGULAR VENT HOLES & WITH EMI COVER

EMI FINGERS

3 = THROUGH THE BEZEL

OPTIONAL LIGHT PIPES

6 = WITH LIGHT PIPE (TRIANGULAR OUTLET)
 LEFT ARROW POINTING BOTTOM PORT &
 RIGHT ARROW POINTING TOP PORT
 7 = WITHOUT LIGHT PIPE
 8 = WITH LIGHT PIPE (REVERSED DIRECTION)
 LEFT ARROW POINTING TOP PORT &
 RIGHT ARROW POINTING BOTTOM PORT

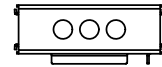
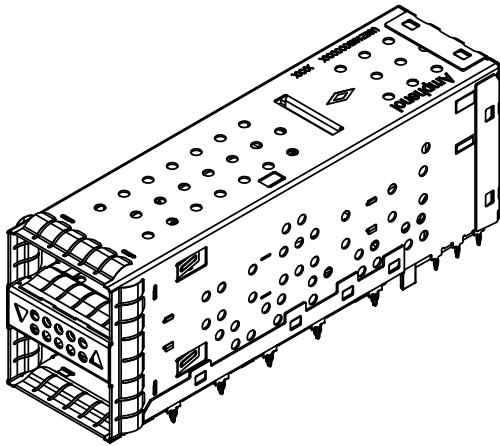

VENT HOLE FOR PART NUMBER U95-Z105-XX71-301

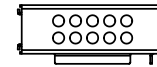

VENT HOLE FOR PART NUMBER U95-Z105-XX71-321

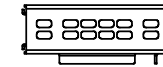

VENT HOLE FOR PART NUMBER U95-Z105-XX71-341

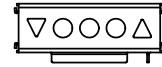

VENT HOLE FOR PART NUMBER U95-Z105-XX61-301

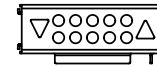

VENT HOLE FOR PART NUMBER U95-Z105-XX61-321

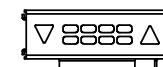

VENT HOLE FOR PART NUMBER U95-Z105-XX61-341

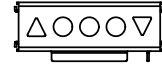

VENT HOLE FOR PART NUMBER U95-Z105-XX81-301

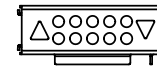

VENT HOLE FOR PART NUMBER U95-Z105-XX81-321



VENT HOLE FOR PART NUMBER U95-Z105-XX81-341

NOTES:

- MATERIAL
 CAGE-PRESS FIT: COPPER ALLOY, NICKEL PLATED
 CONNECTOR-PRESS FIT: PLASTIC HOUSING, FLAMMABILITY RATING UL94 V-0.
 CONTACTS: PHOSPHOR BRONZE
 PLATING OPTION: SEE AMPHENOL PART ON CONFIGURATION
 EMI FINGERS: PHOSPHOR BRONZE WITH NICKEL PLATING
 LIGHT PIPE: GE LEXAN, OPTICAL GRADE
 DUST COVER (IF ORDERED) SHIPPED LOOSE



UNLESS SPECIFIED OTHERWISE	DRAWN	Alvin C	APR 18/13
PRIMARY UNITS MILLIMETERS	CHECKED	ZLJ	APR 18/13
SECONDARY MILLIMETERS	M.E. APP'D		
REFERENCE IN PARENTHESES	Q.A. APP'D		
GENERAL TOLERANCES	DWG APP'D		
1 DECIMAL PLACE ±0.25	ENG. REL. NO.		
2 DECIMAL PLACES ±0.15	REF.		
ANGULAR DEGREES ±0.5°	THIRD ANGLE PROJECTION		

Amphenol High Speed Interconnects A Division of Amphenol Corp. www.amphenol-highspeed.com			
UltraPort QSFP+ 2X1 STACKED COMBO THROUGH BEZEL 4X25G			
DWG. NO.	P-U95-Z105-XXX1-3X1		REV H
CODE ID NO.	03554	DWG SIZE: C	SCALE: 1:1 SHEET 1 OF 4

REVISIONS			
REV	DESCRIPTION, ECN, EAR NO.	DATE	APPD
F	True position tolerance changed plus x-hatch on PCB removed	NOV 11/15	JS
G	Front & Rear EMI pin position added	AUG 29/16	JS
H	Pinout info added	APR 26/17	JS

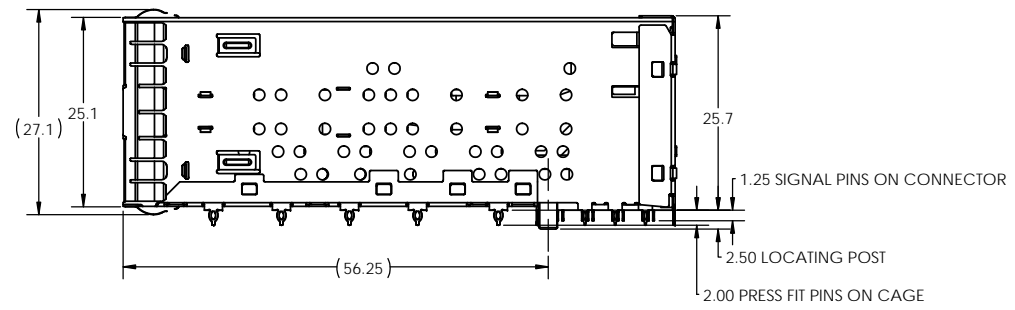
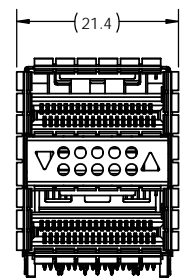
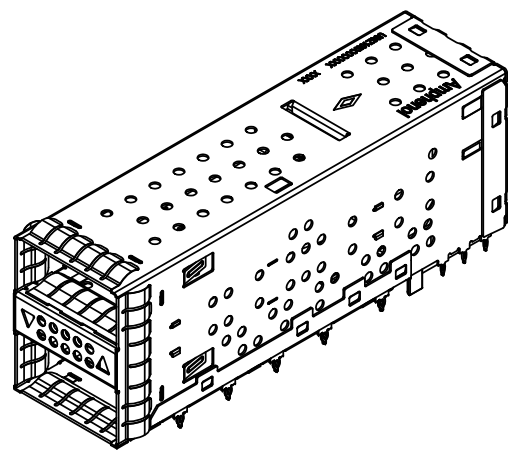
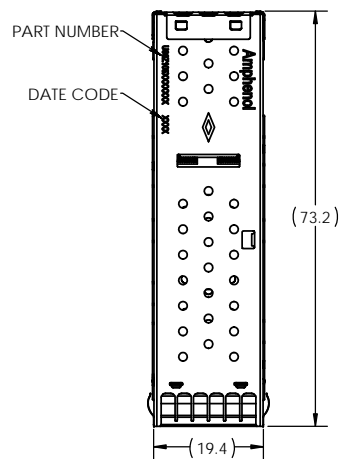

THIS DOCUMENT CONTAINS PROPRIETARY INFORMATION AND SUCH INFORMATION MAY NOT BE DISCLOSED TO OTHERS FOR ANY PURPOSE OR USED FOR MANUFACTURING PURPOSES WITHOUT WRITTEN PERMISSION FROM AMPHENOL CANADA CORP.

UNLESS SPECIFIED OTHERWISE	DRAWN	Alvin C	APR 18/13
PRIMARY UNITS MILLIMETERS	CHECKED	ZLJ	APR 18/13
SECONDARY MILLIMETERS	M.E. APPD		
REFERENCE IN PARENTHESES	Q.A. APPD		
GENERAL TOLERANCES	DWG APPD		
1 DECIMAL PLACE ±0.25	ENG. REL. NO.		
2 DECIMAL PLACES ±0.15	REF.		
ANGULAR DEGREES ±0.5°	THIRD ANGLE PROJECTION		DO NOT SCALE DRAWING

Amphenol High Speed Interconnects
A Division of Amphenol Corp. www.amphenol-highspeed.com

**UltraPort QSFP+ 2X1
STACKED COMBO
THROUGH BEZEL
4X25G**

DWG. NO. **P-U95-Z105-XXX1-3X1** REV **H**

CODE ID NO. 03554 DWG SIZE: C SCALE: 1:1 SHEET 2 OF 4

REVISIONS			
REV	DESCRIPTION, ECN, EAR NO.	DATE	APP'D
F	True position tolerance changed plus x-hatch on PCB removed	NOV 11/15	JS
G	Front & Rear EMI pin position added	AUG 29/16	JS
H	Pinout info added	APR 26/17	JS

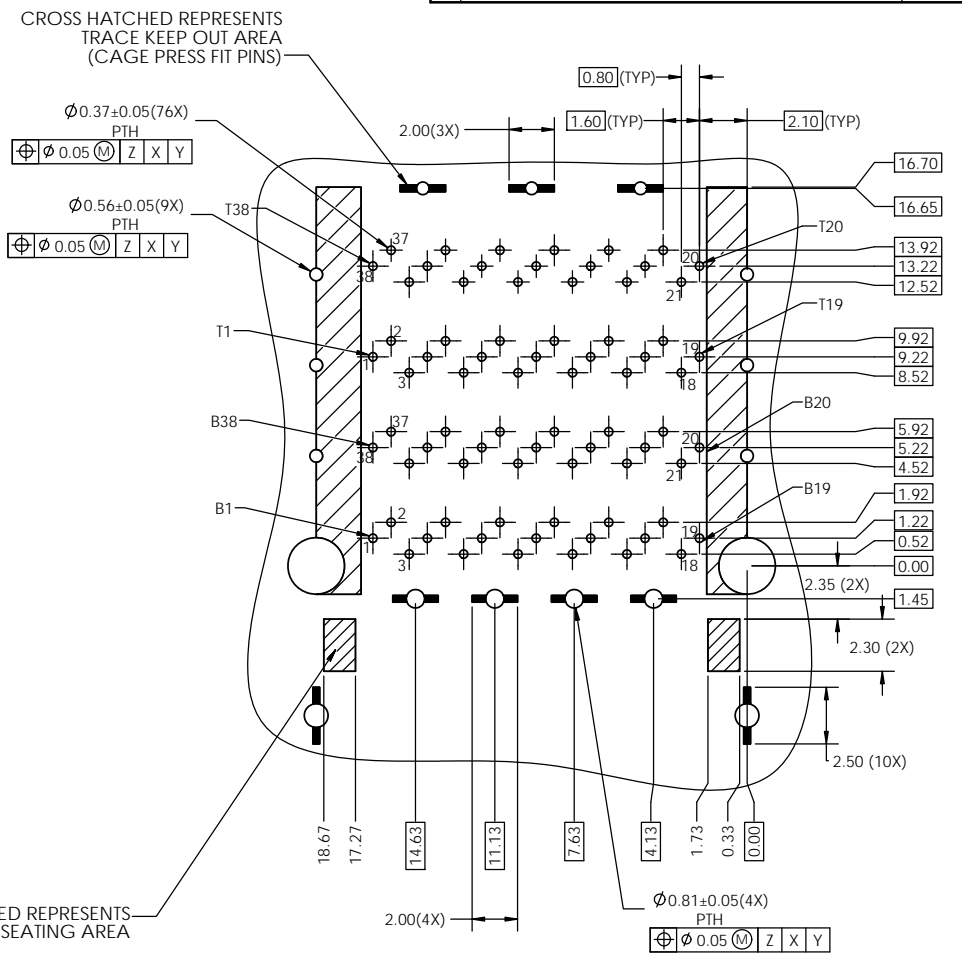
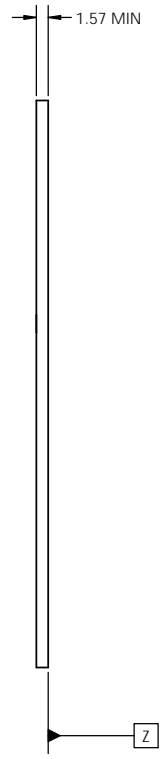
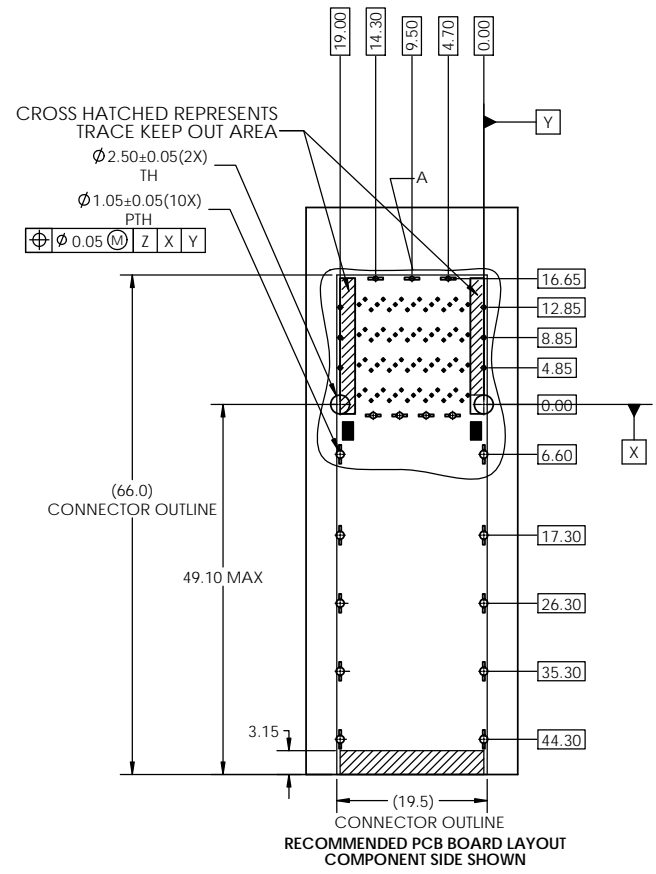

DETAIL A
SCALE 6:1

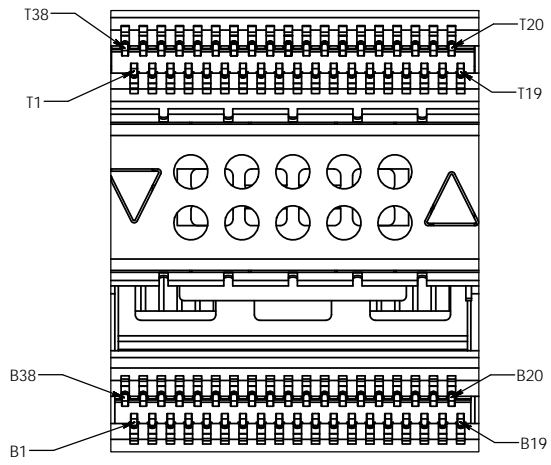

CROSS HATCHED REPRESENTS LED SOLDER PAD SEATING AREA



UNLESS SPECIFIED OTHERWISE	DRAWN	Alvin C	APR 18/13
PRIMARY UNITS MILLIMETERS	CHECKED	ZLJ	APR 18/13
SECONDARY MILLIMETERS	M.E. APP'D		
REFERENCE IN PARENTHESES	Q.A. APP'D		
GENERAL TOLERANCES	DWG APP'D		
1 DECIMAL PLACE ± 0.25	ENG. REL. NO.		
2 DECIMAL PLACES ± 0.15	REF.		
ANGULAR DEGREES $\pm 0.5^\circ$	THIRD ANGLE PROJECTION	DO NOT SCALE DRAWING	

Amphenol High Speed Interconnects
A Division of Amphenol Corp. www.amphenol-highspeed.com

UltraPort QSFP+ 2X1 STACKED COMBO THROUGH BEZEL 4X25G

DWG. NO. **P-U95-Z105-XXX1-3X1** REV **H**

CODE ID NO. 03554 DWG SIZE: C SCALE: 2:1 SHEET 3 OF 4

REVISIONS			
REV	DESCRIPTION, ECN, EAR NO.	DATE	APP'D
F	True position tolerance changed plus x-hatch on PCB removed	NOV 11/15	JS
G	Front & Rear EMI pin position added	AUG 29/16	JS
H	Pinout info added	APR 26/17	JS

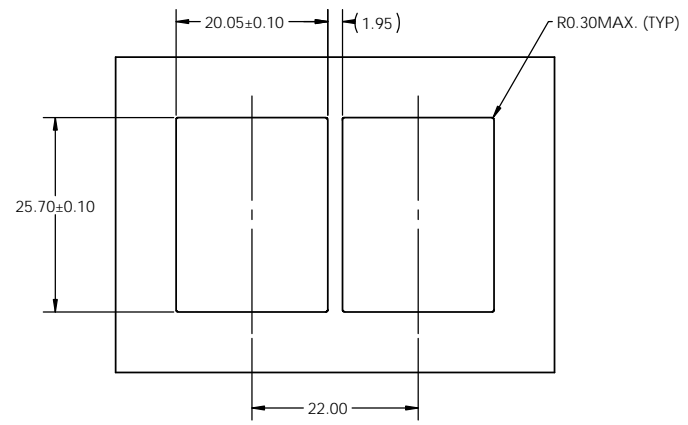
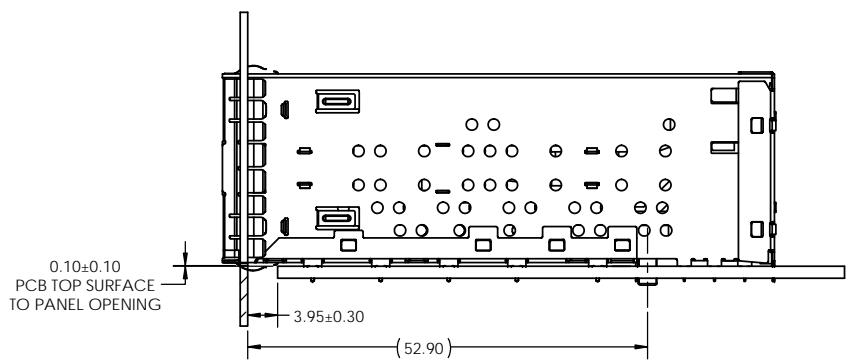

UNLESS SPECIFIED OTHERWISE	DRAWN	Alvin C	APR 18/13
PRIMARY UNITS MILLIMETERS	CHECKED	ZLJ	APR 18/13
SECONDARY MILLIMETERS	M.E. APP'D		
REFERENCE IN PARENTHESES	Q.A. APP'D		
GENERAL TOLERANCES	DWG APP'D		
1 DECIMAL PLACE ±0.25	ENG. REL. NO.		
2 DECIMAL PLACES ±0.15	REF.		
ANGULAR DEGREES ±0.5°	THIRD ANGLE PROJECTION		DO NOT SCALE DRAWING

Amphenol High Speed Interconnects
A Division of Amphenol Corp. www.amphenol-highspeed.com

**UltraPort QSFP+ 2X1
STACKED COMBO
THROUGH BEZEL
4X25G**

DWG. NO. **P-U95-Z105-XXX1-3X1** REV **H**

CODE ID NO. 03554 DWG SIZE: C SCALE: 1:1 SHEET 4 OF 4

THIS DOCUMENT CONTAINS PROPRIETARY INFORMATION AND SUCH INFORMATION MAY NOT BE DISCLOSED TO OTHERS FOR ANY PURPOSE OR USED FOR MANUFACTURING PURPOSES WITHOUT WRITTEN PERMISSION FROM AMPHENOL CANADA CORP.

X-ON Electronics

Largest Supplier of Electrical and Electronic Components

Click to view similar products for [I/O Connectors](#) category:

Click to view products by [Amphenol](#) manufacturer:

Other Similar products are found below :

[571763P](#) [58098-0628](#) [72.250.1628.2](#) [72.250.2428.2](#) [74720-0505](#) [76.350.0729.0](#) [76871-1403](#) [FCN-244F080-G/1](#) [FCN-260A9920](#) [MP-5T180MUNNA-005](#) [PCR-E36PM](#) [PCS-XE26MA+](#) [G38A71314B](#) [1571250010](#) [157-22500-3](#) [MS3471L14-19P L/C](#) [192991-0703](#) [172501-4002](#) [172501-6002](#) [FCN-260C008-A/L0](#) [FCN-260C024-AL0](#) [FCN-261Z008](#) [2000314-1](#) [200331-1](#) [PCR-E36FC+](#) [PCS-E28FS+](#) [PCS-XE26SLFD+](#) [PCS-XE26SLFDT+](#) [G730VID08BDC24](#) [HDR-E14MSG1+](#) [U90B2054081210](#) [UE86K842720321](#) [38113800006](#)
[DP3AR020WQ1R200](#) [Z4.102.0680.0](#) [500-1040](#) [500-1052](#) [500-1054](#) [ZP-4008-66L](#) [0709821002](#) [DX40-20P\(55\)](#) [5554841-1](#) [MS3474W18-8P-LC*](#) [SM3106F14S-7S-LC](#) [U90B3054061110](#) [U65-E04-4020](#) [ZPF000000000097891](#) [557-262M2-06C](#) [747360449](#) [10099439-003C-TRLF](#)