

USBF TV (USB-A)

USB connection system for harsh environment



With USB Field, you can insert a standard USB 2.0 cordset into a metallic plug which will protect it from shocks, dust and fluids.

No hazardous on-field cabling and grounding!

This metallic plug is connected into a receptacle, using a Tri Start Thread coupling mechanism (MIL-DTL-38999 series III type) with anti-decoupling device for high vibrations.

Applications

- Embedded computers
- Data acquisition and transmission in harsh environment
- Railways
- Battelfield communication systems
- Navy systems

Data transmission

USB specification 2.0
Data rate: up to 480 Mbps for high speed USB

Main characteristics

- Sealed against fluids and dusts (IP68)
- Shock, vibration and traction resistant
- No cabling operation in field and no tools required
- Improved EMI protection
- Tri Start Thread coupling mechanism (MIL-DTL-38999 series III type) with anti-decoupling device - Shell size 15
- 2 mechanical coding / polarization possibilities by the user (receptacle insert rotation)
- USBF TV plug retention in the receptacle: 100 N in the axis
- Mating cycles: 500 minimum

Environmental protection

- Sealing (when mated): IP68 (temporary immersion)
- Salt spray: 48 h with nickel plating
> 500 h with olive drab cadmium
1000 h with marine bronze shell
- Fire retardant / low smoke: UL94 V0 and NF F 16 101 & 16 102
- Vibrations: 10 – 500 Hz, 10 g, 3 axes: no discontinuity > 1micro s
- Shocks: IK06: weight of 250 g drop from 40 cm [15.75 in] onto connectors (mated pair)
- Humidity: 21 days, 43°C, 98% humidity
- Temperature range: - 40°C / +85°C

Part number code

Series	USBF TV	2	1	G
USB Field TV				
Shell type				
6: plug				
2: square flange receptacle				
2PE: square flange receptacle with metal backshell (type 1) & with metal backshell + plastic gland (type 2)				
2PEM: square flange receptacle with backshell + metal gland (only for back termination type 2 = Solder)				
7: jam nut receptacle				
7PE: jam nut receptacle with metal backshell (type 1) & with metal backshell + plastic gland (type 2)				
7PEM: jam nut receptacle with backshell + metal gland (only for back termination type 2 = Solder)				
Back terminations (receptacles only)				
1: female USB-A				
2: solder (4 tinned holes)				
Shells material & finish				
N: aluminium shell - nickel plating - ROHS compliant				
G: aluminium shell - olive drab cadmium plating				
BZ: marine bronze shell - ROHS compliant				

- Examples:
- Olive drab cadmium plug: USBF TV 6G
 - Olive drab cadmium square flange receptacle, USB-A back terminat^o: USBF TV 21G
 - Olive drab cadmium jam nut receptacle, USB-A receptacle back terminat^o: USBF TV 71G
 - Nickel jam nut receptacle, solder back termination: USBF TV 72N

Plug

- Shell type 6

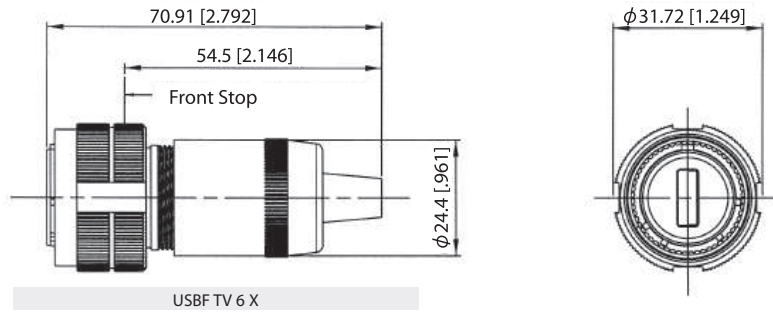

Receptacles

- Square flange receptacle
- 4 mounting holes: shell type 2

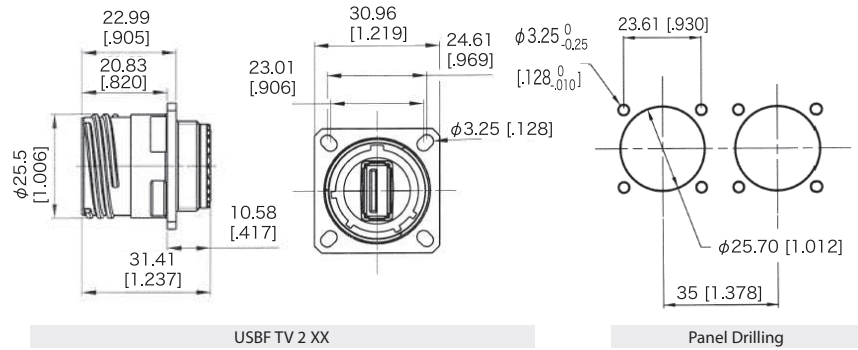

- Jam nut receptacle
- Hexagonal nut mounting: shell type 7

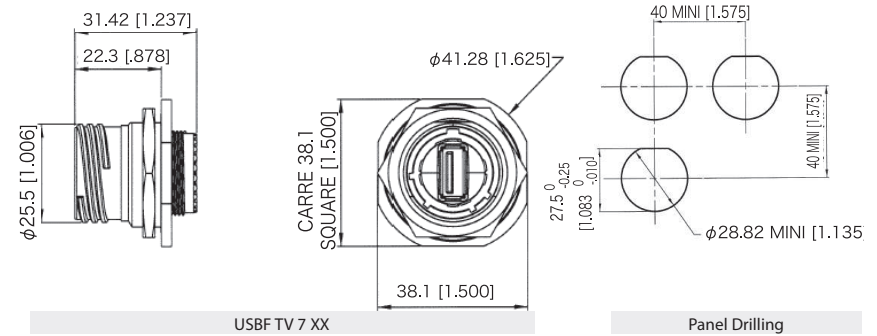

- Receptacles with backshell:
- Shell type 2PE and 7PE

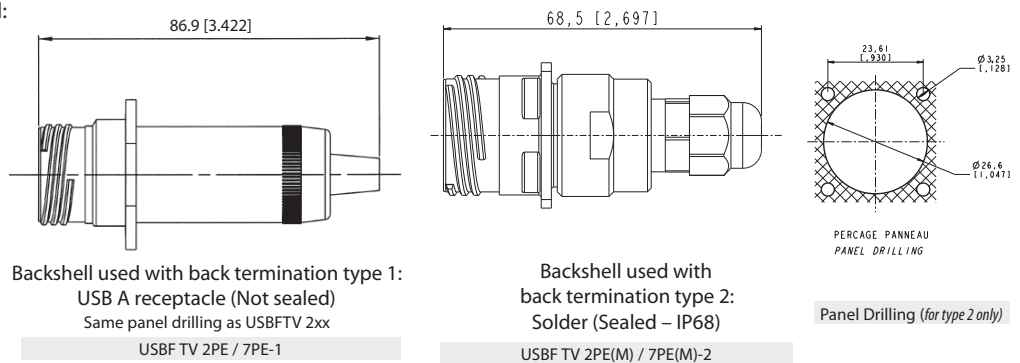

Back terminations

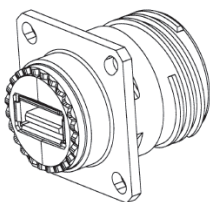

Type 1: female USB-A

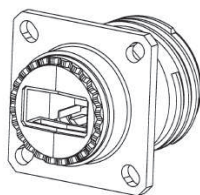

Type 2:
solder 4 Tinned holes to solder your cable

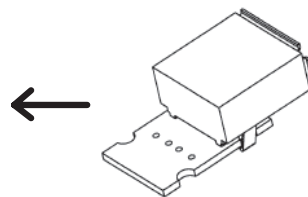

View of the PCB of the Type 2 version with
4 tinned holes for solder termination

Assembly instructions

Can be used with most the USB cordset brands : No tools required!

Plug assembly

1. Only if you need a full sealing (IP68): Install the white sticker around the plug, covering the 4 little holes of the overmolding
2. Insert the black O Ring around the front face of the USB A plug. This O Ring will ensure connection sealing
3. Insert the USB cordset into the metallic backshell
4. Insert the retention spacer laterally to the cable (this spacer is soft, in order to adapt to different shapes of overmolding) and slide the overmolding of the USB-A plug into this retention spacer
5. Insert the friction ring laterally to the cable
6. Choose the right coding (2 positions) and insert the USB-A plug into the protective plug. Note at this step, the main key is used for polarization.

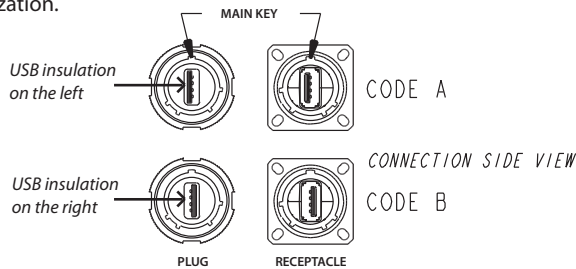

7. Screw the backshell on the plug body. A wrench can be necessary to fully tighten it, and the connection to the receptacle can help

IMPORTANT NOTE

The connection sealing is not done by the black retention spacer (which is slotted), but by the front face ORing (fig.2)

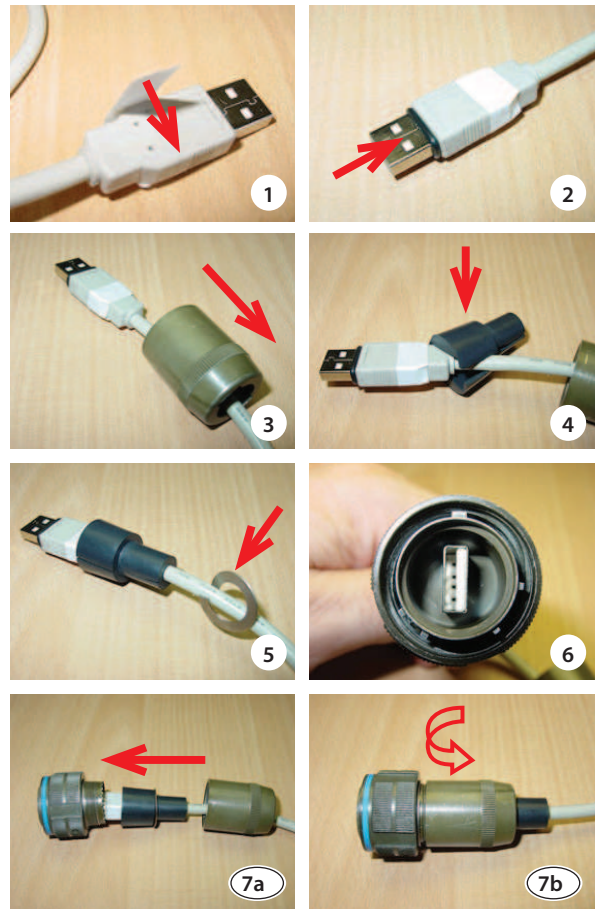

Receptacle assembly

Insert the USB module from the rear. Reference is main key. Beware to have a coding compatible with the coding you used for the plug: on front view, the white shapes in the USBs must be on the same side.

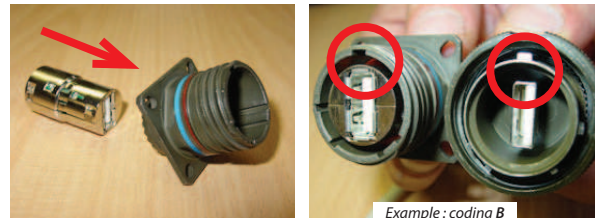

To remove the USB module, insert the removal tool **USBF ODE** from the Front, and push back the module.



Accessories

■ Metallic caps

	USBF TVC	2	G
Connector type			
6: plug			
2: square flange receptacle			
7: jam nut receptacle			
Shells material & finish			
N: aluminium shell - nickel - ROHS compliant			
G: aluminium shell - olive drab cadmium			
BZ: marine bronze shell - ROHS compliant			

- Panel gasket for square flange receptacle
Thickness: 0,8 mm [.031]
P/n: **JE15**

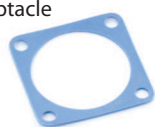

- Receptacle insert removal tool: p/n **USBF ODE**

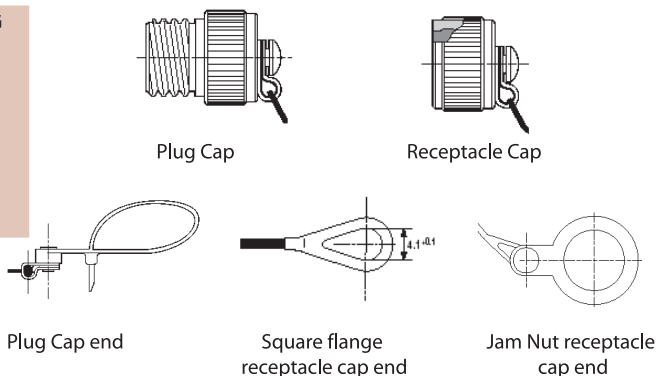

USBF TV

Transversally sealed receptacles



In some applications, a transversal sealing for the receptacle is a « must ». This will prevent fluids and dust from going through the receptacle when plug or cap are not mated to the receptacle. The sealed solution (version "S") has a compound at the rear of the receptacle below. In addition, the Sealed USBF TV has been successfully tested in very high vibration corresponding to airplane applications.

Applications

- Embedded computers
- Data acquisition and transmission in harsh environment
- Railways
- Battelfield communication systems
- Navy systems

Data transmission

USB specification 2.0
Data rate: up to 480 Mb/s for high speed USB

Main characteristics

- Sealed against fluids and dusts (IP68)
- Shock, vibration and traction resistant
- No cabling operation in field and no tools required
- Improved EMI protection
- Tri Start Thread coupling mechanism (MIL-DTL-38999 series III type) with anti-decoupling device - Shell size 15
- 2 mechanical coding/polarization possibilities by the user (receptacle insert rotation)
- USBF TV plug retention in the receptacle: 100 N in the axis
- Mating cycles: 500 minimum

Environmental protection

- Sealing (when mated): IP68 (temporary immersion)
- Salt spray: 48 h with nickel plating
> 500 h with olive drab cadmium
1000 h with marine bronze shell
- Fire retardant / Low smoke: UL94 V0 and NF F 16 101 & 16 102
- Vibrations: 10 – 500 Hz, 10 g, 3 axes: no discontinuity > 1 micro s
- Shocks: IK06 ► weight of 250 g drop from 40 cm [15.75 in] onto connectors (mated pair)
- Humidity: 21 days, 43°C, 98% humidity
- Temperature range: - 40°C / +85°C

Part number code

Series	USBF TV	2PES	A	2	N	03	A
USB Field TV							
Shell Type							
2S : square flange receptacle							
2PES: square flange receptacle + backshell + plastic gland							
2PEMS: square flange receptacle + backshell + metal gland							
7S: jam nut receptacle							
7PES: jam nut receptacle + backshell + plastic gland							
7PEMS: jam nut receptacle + backshell + metal gland							
Coding							
"A" (Standard) or "B"							
Back terminations							
2: rugged USB cable (see corresponding datasheet page 109)							
Shells plating							
N: nickel							
G: olive drab cadmium							
USB cable length							
03: 30 cm [11.81 inches]							
05: 50 cm [19.68 inches]							
10: 1 meter [39.37 inches]							
USB cable end							
A: standard USB-A plug							
OPEN: open cable (no connector)							

Examples: - Olive drab cadmium square flange receptacle with 30 cm of USB cable and standard USB-A plug: USBF TV 2S G 03 A
- Nickel jam nut receptacle + backshell + plastic gland, with 1 meter of USB cable, and a standard USB-A plug: USBF TV 7PES N10 A

Receptacles

■ Square flange receptacle 4 mounting holes: shell type 2

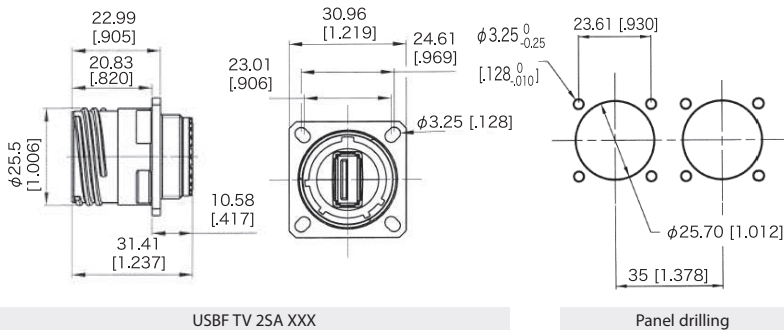

■ Jam nut receptacle hexagonal nut mounting: shell type 7

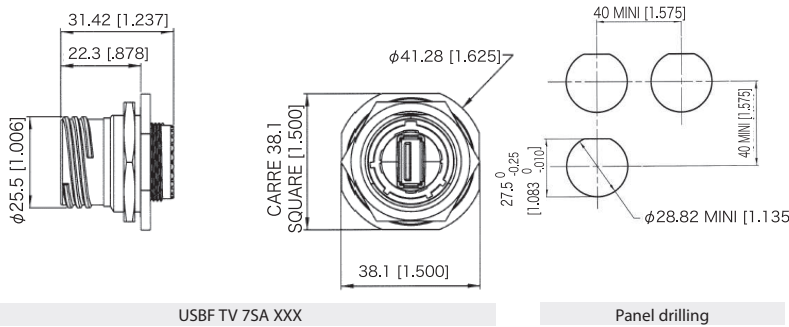

■ Jam nut receptacle hexagonal nut mounting: shell type 7

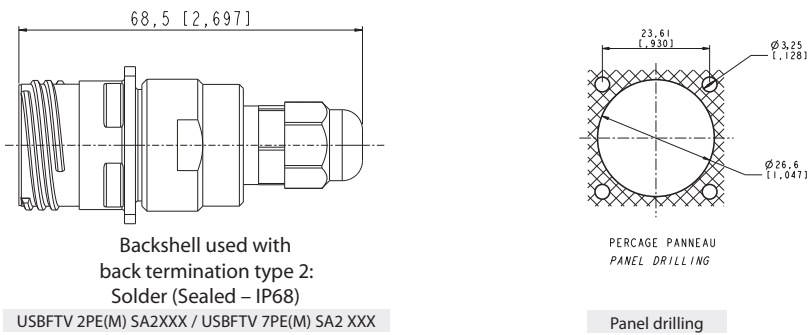

Cordset end

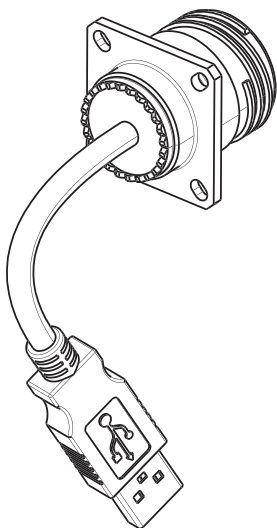

USB cable end type "A"

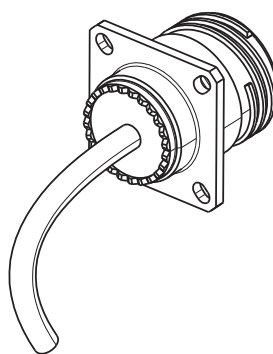

USB cable type "OPEN"



USBF TV

Hermetic receptacles



In some applications, a transversal hermiticity for the receptacle is a « must ». This will prevent gas from going through the receptacle when plug or cap are not mated to the receptacle.

The hermetic solution (version "H") has a compound at the rear of the receptacle. Helium leakage is less than 1.10^{-6} cm³ per second [0.1 micron cubit ft per hour] at one bar [15 psi] pressure differential.

Applications

- Embedded computers
- Data acquisition and transmission in harsh environment
- Railways
- Battelfield communication systems
- Navy systems

Data transmission

USB specification 2.0
Data rate: up to 480 Mb/s for high speed USB

Main characteristics

- Same as the USBF TV (see page 76)... a complete IP68 sealing of the receptacle is added (even with no plug or no protective cap mated).
- Outside dimensions are the same as the standard USBF TV (USB-A).
- Vibrations : the compounded version of the USBF TV has been tested in vibration following the NAS 1599 aeronautic specification (ambient temperature): 5 - 3000 Hz, 20g, 2.5 mm [.1 inch] double amplitude, 3 axes, 12 hours
Note: this specification exceeds MIL-C-26500 requirements.

IMPORTANT NOTE

Due to the compound, the coding of the connector must be done in the factory: use the codes A or B in the part number. **Example:** USBF TV 2H A 2 N 03 A

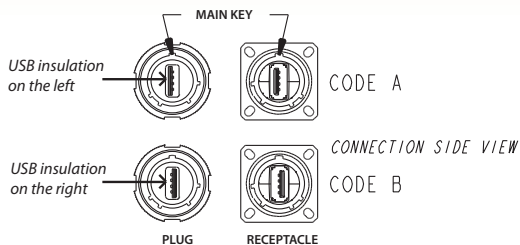

Part number code

Series	USBF TV	2H	A	2	N	03	A
USB Field TV							
Shell type							
2H :	hermetic square flange receptacle						
2PEH:	hermetic square flange receptacle + backshell + plastic gland						
2PEMH:	hermetic square flange receptacle + backshell + metal gland						
7H:	hermetic jam nut receptacle						
7PEH:	hermetic jam nut receptacle + backshell + plastic gland						
7PEMH:	hermetic jam nut receptacle + backshell + metal gland						
Coding							
"A" (standard) or "B"							
Back terminations							
2:	rugged USB cable (see corresponding datasheet page 109)						
Shells plating							
N:	nickel						
G:	olive drab cadmium						
USB cable length							
03:	30 cm [11.81 inches]						
05:	50 cm [19.68 inches]						
10:	1 meter [39.37 inches]						
USB cable end							
A:	standard USB-A plug						
OPEN:	open cable (no connector)						

Examples: - Olive drab cadmium hermetic square flange receptacle with 30 cm of USB cable and standard USB-A plug: USBF TV 2H G 03 A
- Nickel hermetic jam nut receptacle + backshell + plastic gland, with 1 meter of USB cable, and a standard USB-A plug: USBF TV 7PEH N10 A



USBF TV

Receptacles with 360° EMI backshells



USBFTV receptacles series with EMI backshells provide 360° shielding: same protection than the one proposed per standard MIL-DTL-38999 serie III connectors. We offer these EMI backshells with square flange and jam nut receptacles. The available platings are nickel or olive drab cadmium. With those solutions we suggest using our reinforced USB cable (shielded – zero halogen jacket) ► see page 109

We can provide those receptacles:

- with cordset already soldered
- without cordset

Example with a square flange receptacle (provided without cable)

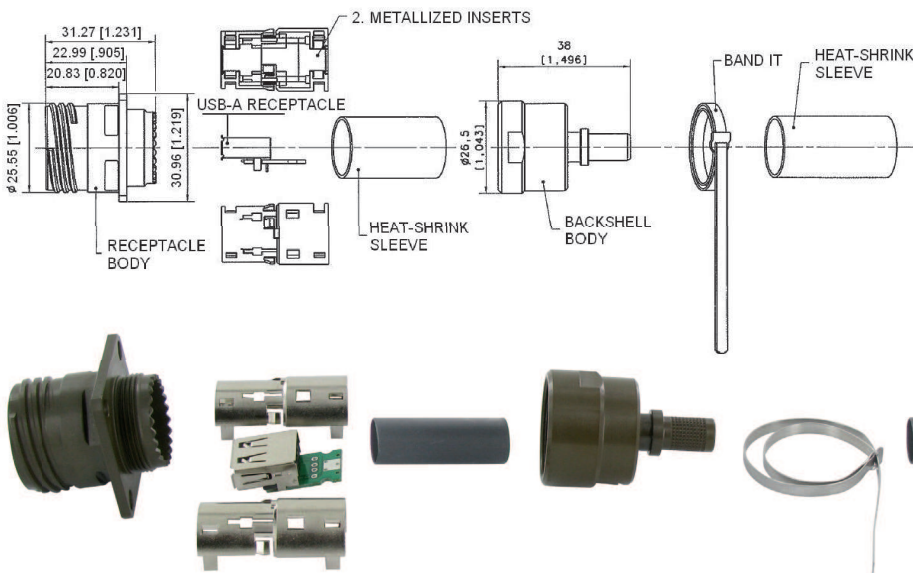

Part number	Plating	Square flange receptacle	Jam nut receptacle
	Nickel - ROHS compliant	KIT40263	KIT40245
Olive drab cadmium	KIT40263G	KIT40245G	

IMPORTANT NOTE

With receptacles provided without cable, customer will have to solder his cable on the PCB ; please find below the cabling specification.

If customer prefers to use his cable, please check with us compatibility with our EMI backshells: www.usbfield.com

WIRES AND SHIELDING WIRE CABLING ON THE PCB

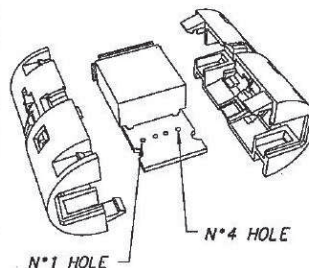
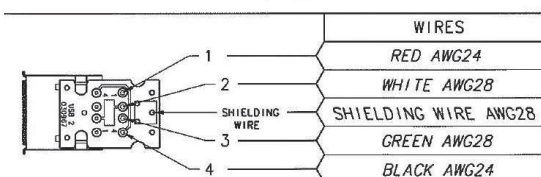



USBF TV

Through bulkhead

Receptacle

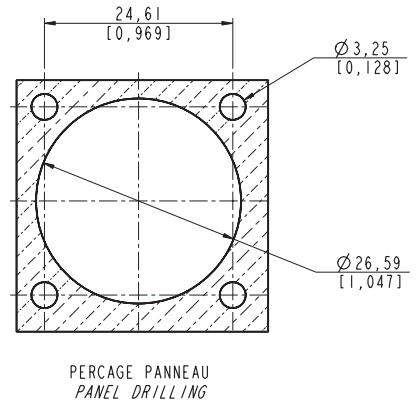
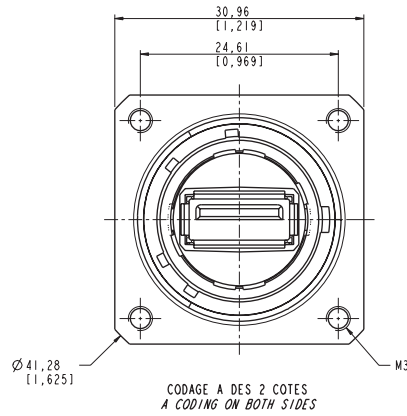
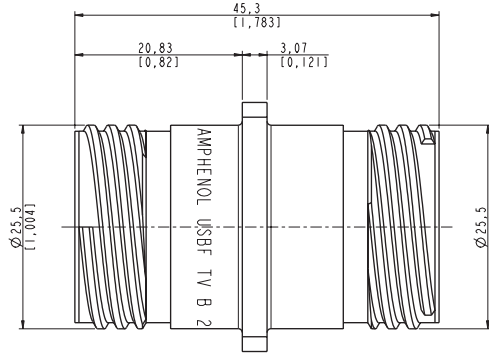

Part number	Plating	P/N
	Nickel - ROHS compliant	USBF TV B 2 N
	Olive drab cadmium	USBF TV B 2 G

Nota : could be used with plug USBFTV, nickel and olive drab cadmium. See page 97.

USBF TV

Stand off receptacles

These receptacles can be soldered directly to your PCB. A compound insures a transversal sealing and good performance in high-vibration environments.
The shell of those receptacles are in the "Stand Off" style.
They can be connected with rugged USBF TV series plugs.

Square flange receptacle

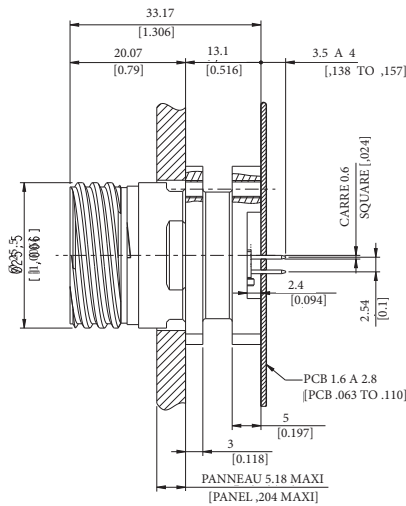

Datas for coding A

Coding B is also available, please consult us.

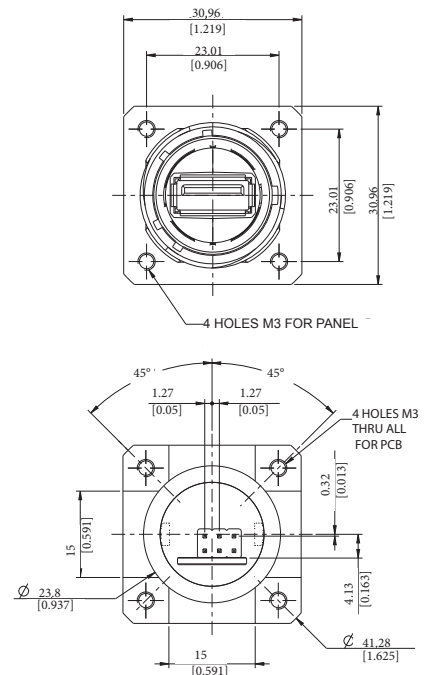

Part number	Plating	P/N for coding A	P/N for coding B
	Nickel - ROHS compliant	USBF TV 25 N F459	USBF TV 2S B 5 N F459
	Olive drab cadmium	USBF TV 25 G F459	USBF TV 2S B 5 G F459

Connection side view

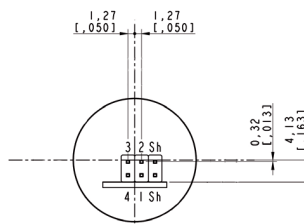
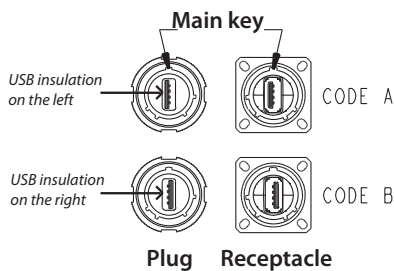

Coding A - Pins position :
1 & 4 = Power - Red & black wires USB2.0 cable
2 & 3 = Signal - White & green wires USB2.0 cable
Sh = Shield

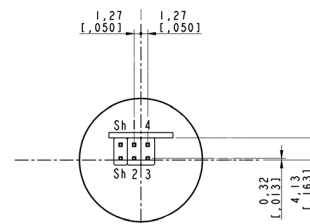

Coding B - Pins position :
1 & 4 = Power - Red & black wires USB2.0 cable
2 & 3 = Signal - White & green wires USB2.0 cable
Sh = Shield

Recommended PCB hole LAYOUT (Coding A) - Solder side view

Nota : for coding B, please consult us.

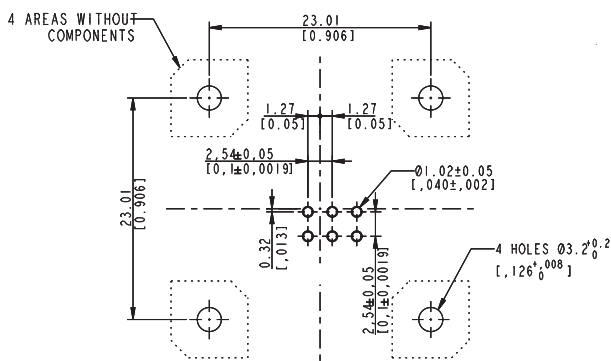

Panel drilling

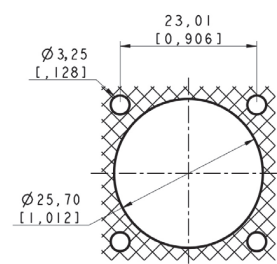

Jam nut receptacle

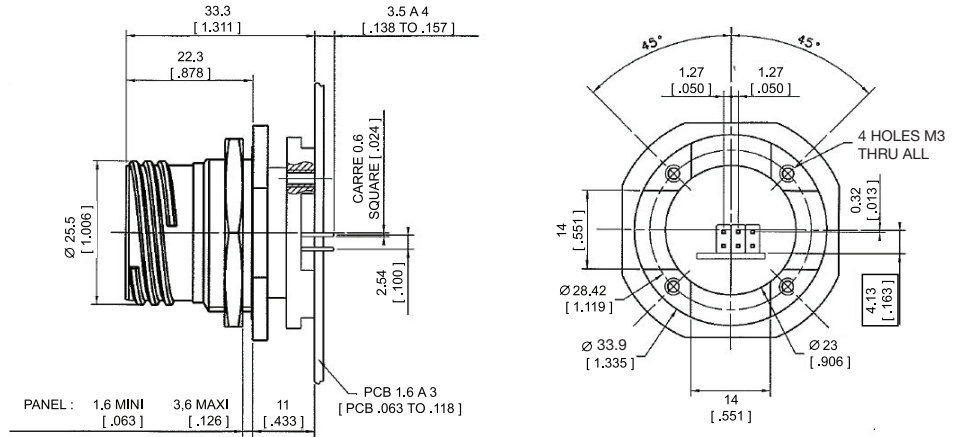

Part number	Plating available	P/N for coding A	P/N for coding B
	Nickel - ROHS compliant	USBF TV 75 N F459	USBF TV 75 B 5 N F459
Olive drab cadmium	USBF TV 75 G F459	USBF TV 75 B 5 G F459	

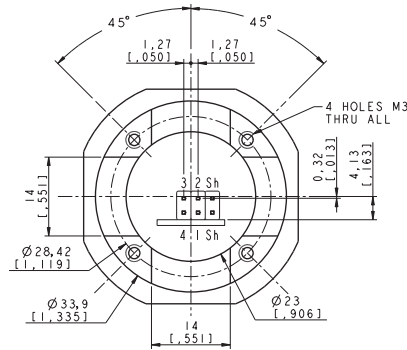
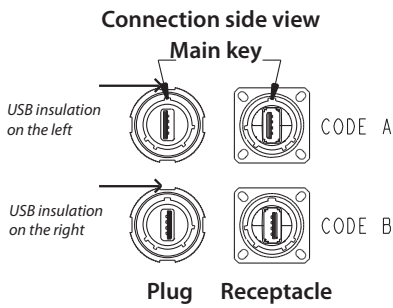

Coding A - Pins position:
 1 & 4 = Power - Red & black wires USB2.0 cable
 2 & 3 = Signal - White & green wires USB2.0 cable
 Sh = Shield

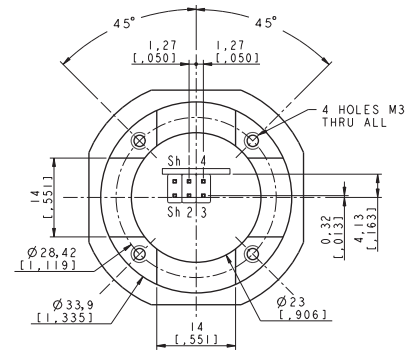

Coding B - Pins position:
 1 & 4 = Power - Red & black wires USB2.0 cable
 2 & 3 = Signal - White & green wires USB2.0 cable
 Sh = Shield

Recommended PCB hole LAYOUT

Solder side view

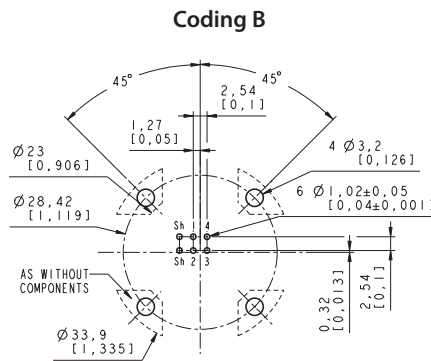
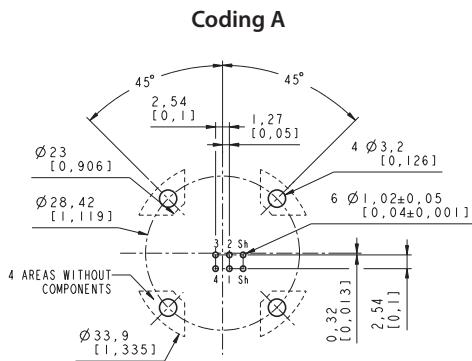

Panel drilling

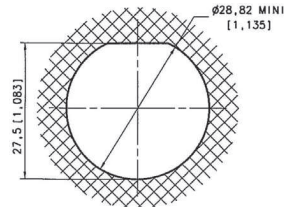

USB 2.0 Receptacle with Self Closing Cap



This Self Closing Cap automatically protects the USB Field square flange receptacles (MIL-C-26482 type), protecting your system from dust and water projections. The same cap can be used to protect RJ45, USB3.0, USBB and IEEE1394 receptacles. A spring automatically closes the upper part of the cap when either the RJ Field plug, RJ45 cordset, USB or IEEE1394 cordset, or USB key are removed from the receptacle.

USBF 21 X SCC

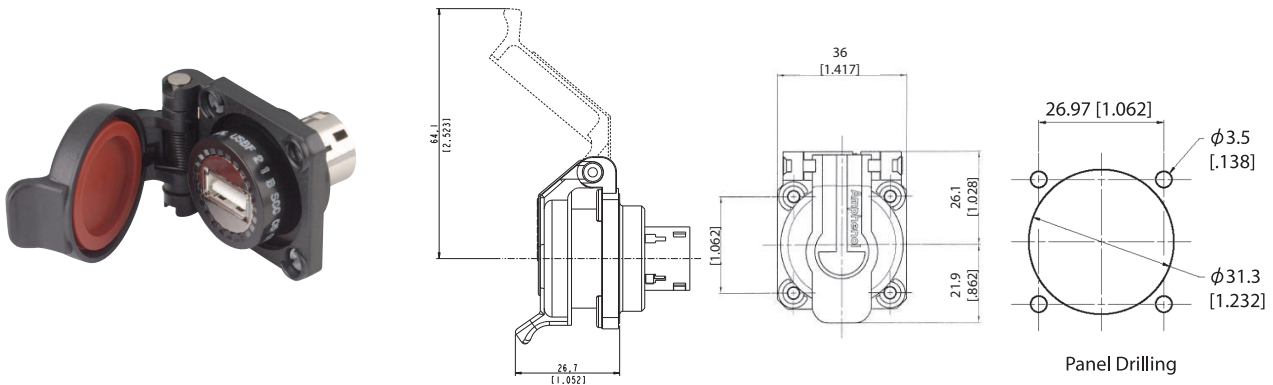

Version: USB-A (front and back termination)

Part number *	Plating		Metallized inserts (EMI)	
	Part number *	Plating	Metallized inserts (EMI)	
USBF 21B SCC	Black coated	No (blank insert)		
USBF 21N SCC	Nickel plated	Yes		
USBF 21G SCC	Olive drab cadmium plated	Yes		

* The part number includes the receptacle + the self closing cap

■ Note: Panel gasket with any of these receptacles: JE18



RJF 21 X SCC, USBBF 21 X SCC, & IEEE1394



RJ45 version
(see page 25)



USB3.0-A version
(see page 94)



USB-B version
(see page 118)



IEEE1394 version
(see page 143)

Metallic Self Closing Cap (SCC)

For USBF TV 2.0 square flange receptacles.

This Self Closing cap automatically protects the USBF TV (2.0 - type A) square flange receptacles (MIL-DTL-38999 type), protecting your system from dust and water projection.

A spring automatically closes the upper part of the cap when the USB plug is removed from the receptacle.

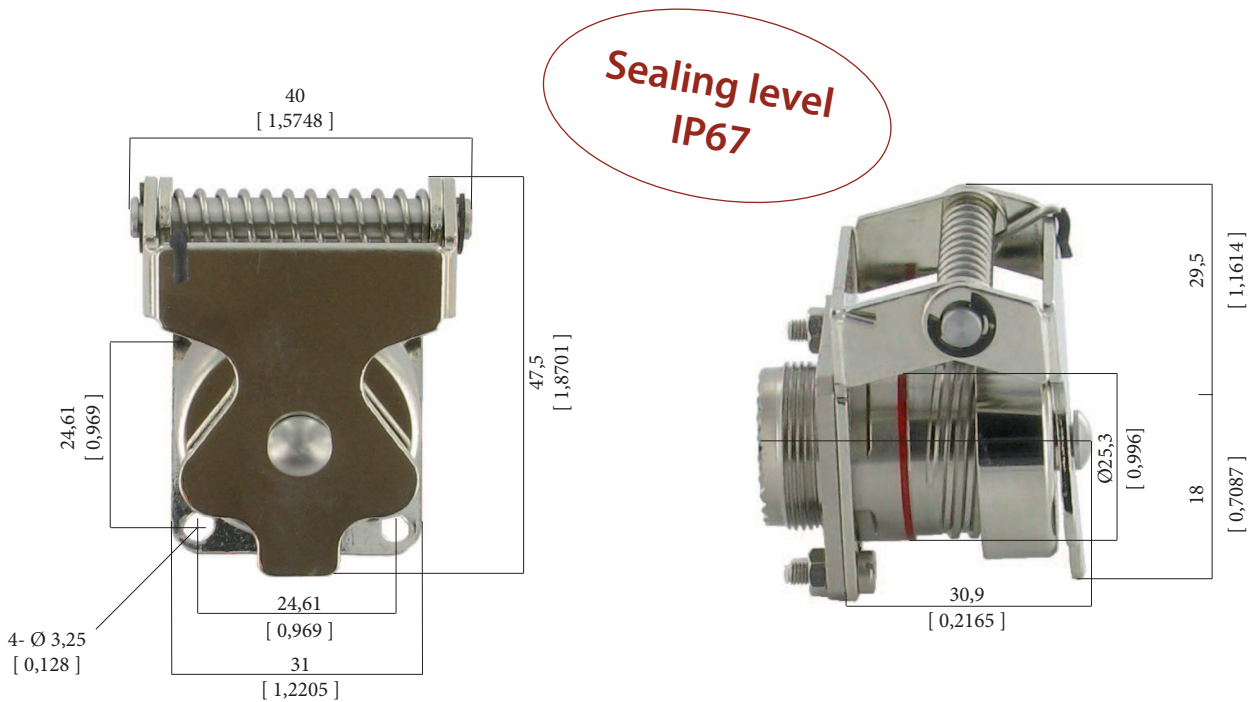

IMPORTANT NOTE

Metal Self Closing cap are sold separately (without receptacle).



Part number	Plating	P/N
	Black - ROHS compliant	USBFTVSCCB
	Nickel - ROHS compliant	USBFTVSCCN
	Olive drab cadmium	USBFTVSCCG

Remark: also compatible with USB3FTV (type A) & USBBFTV (type B) square flange receptacles:

USB3FTVXX (see page 95)

USBBFTV2XX (see page 119)

■ Panel gasket for square flange receptacle (thickness: 0,8 mm [.031]):

Part number: **JE15**

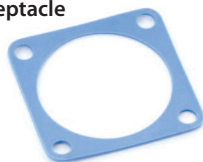

X-ON Electronics

Largest Supplier of Electrical and Electronic Components

Click to view similar products for [USB Connectors](#) category:

Click to view products by [Amphenol](#) manufacturer:

Other Similar products are found below :

[65-647-8-BK-BU](#) [950](#) [E8144-B01021-L](#) [A-USB A-LP-SMT-C](#) [A-USB B-TOP-C](#) [MUSBA511N5](#) [MUSBD11135](#) [217450-1](#) [CA 6 W LD](#)
[KMBVX-TH-5S-B30](#) [896-30-004-00-000000](#) [KUSBVX-BS1N-W30](#) [KUSBX-AP-KIT-SCBLK](#) [KUSBX-AS2N-W](#) [KUSBX-SMT2AP1S-W](#)
[KUSBX-SMT2AP1S-W30](#) [935](#) [957](#) [30-498-6](#) [17-210051](#) [1734082-1](#) [30-1574](#) [30-470](#) [30-489](#) [30-541](#) [30-572-3](#) [MAB 8 SN V](#) [A-USB A-](#)
[2P-C](#) [MIKROE-1451](#) [USBFTV2PEM2G](#) [USBFTVC6ZN](#) [KUSBX-AS2N-W30](#) [KUSBX-SLAS1N-W](#) [KUSBX-SMT-AS1N-W30](#) [4689-1](#) [1-](#)
[1734084-2](#) [E8110-001-01](#) [MUSBA81130](#) [33UBARS1-04SW11](#) [33UBAR-04SW11](#) [USBF21ZNSCC](#) [USBBFTV6ZC](#) [10135326-001LF](#)
[M9177/3-1](#) [USB-A-S-F-B-VT](#) [925](#) [4198](#) [690-024-633-031](#) [KUSBEX-BSFS1N-W](#) [USBFTVC6MRG](#)