

# Amphenol

# PT Series

## PT SERIES

VG 95328  
MIL-C-26482, Series 1  
LN 29500  
BS 9522 N 0001  
NFC 93-422  
NFL 54-125  
Patt. 9522 N 0001 (603)  
Patt. 9522 F 0017 (105)



## General information

The miniature circular connectors of the PT series shown in this catalog are in accordance with MIL-C-26482 series 1 and VG 95328. Amphenol-air LB received approval for military applications as per VG 95328 under authorization no. 14/86.

These connectors must not be connected or disconnected under voltage.

The PT series is mateable and interchangeable with connectors of the following standards:

MIL-C-83723, LN 29500, LN 29504  
NFL 54125, NAS 1599  
DEF 5325-3, DEF 5326-3  
IEC Publ. 130-7

These circular connectors with three pin bayonet couplings are available with solder, crimp, PCB, and wire-wrap connections, and in an HF-sealed version. All series have proven successful in the industrial sector and in particular for aerospace applications as well as for equipment in land vehicles and marine vessels.

Quick installation and a well stocked parts inventory mean that connectors can be supplied at short notice.

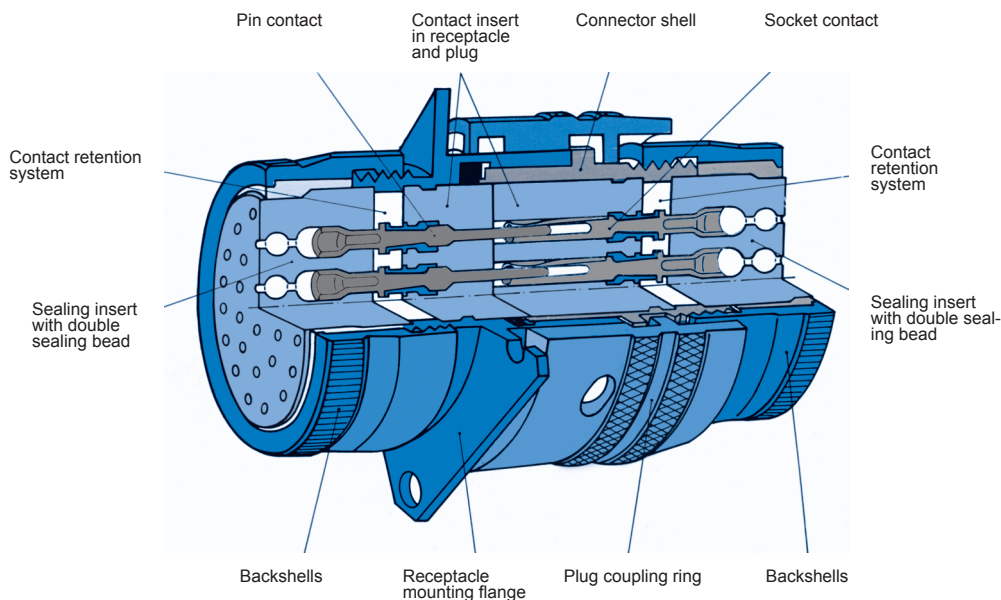

**Receptacle and plug with crimp contacts**

### Safety information

Our products are constantly being developed and improved. Therefore, we reserve the right to change designs for quality improvements, enhancements, or manufacturing needs. All technical specifications concern connectors, which is equipment that cannot be disconnected or separated under voltage.

Series overview	2 - 3
Technical data	4 - 5
Polarization (coding system)	6
Contact arrangements	7 - 9
Connectors – Complete overview	10 - 11
Cross-reference table (PT-MIL-VG)	12 - 13
<b>PT Series</b> (solder connection)	14 - 25
<b>PT Series</b> (solder connection, hermetic)	26 - 29
<b>PT-GS Series</b> (PCB connection)	30 - 37
<b>PT-WW Series</b> (wire-wrap connection)	30+ 38
<b>PT-SE Series</b> (crimp connection)	39 - 52
Accessories	53 - 57
Tools	58 - 59
Assembly instructions	60 - 68
Special designs	68
Ordering information (ordering examples)	69 - 70



Receptacle

Plug

**PT Series**

(solder connection)

The PT series includes plugs and receptacles with **non-removable**, gold plated contacts with solder connections, which are attached by adhesives in a neoprene insert.

The aluminum alloy connector has five guide grooves and lugs, and a three pin bayonet coupling. This creates an absolutely reliable coupling. The wide range of designs, shell sizes and contact arrangements allow a diverse range of applications for industrial and military use.



Receptacle

Plug

**PT-SE Series**

(crimp connection)

The PT-SE series includes plugs and receptacles with **removable**, gold plated contacts with crimp connections, which are held in a contact retainer.

In addition to the proven features of the PT series connectors, PT-SE connectors have excellent properties required for equipment which must handle strong vibration levels, for example in aircraft and land vehicles.



Receptacle with PCB connection

**PT-GS Series**

(PCB connection)

This series contains receptacles with **non-removable** contacts designed for soldering in rigid or flexible PCBs. All design features are identical to those of the PT series.



Receptacle with wire-wrap connection

**PT-WW Series**

(wire-wrap connection)

This series contains receptacles with **non-removable** contacts designed for wire-wrap connections. All other design features are identical to those of the PT series. The cross-section of the wire-wrap pin is 0.6 x 0.6 mm and corresponds to the specifications in DIN 41611, Sheet 2.

### Other series

In addition to the main series PT and PT-SE, the following series available in the PYGMY connector family are not included in this catalog.  
For more information please send us your inquiry.

**PT Series** (bayonet coupling)

**SP Series** (bayonet coupling)  
for harsh environmental conditions

#### SP Series

Connectors with solder contacts. Differences to PT and PT-SE series: Larger mounting flange, hard anodized, non-conductive surface.

#### SP-SE Series

Connectors with removable crimp contacts and retention clip.

#### SP-CE Series

Connectors with removable crimp contacts and contact retainer.

**PC Series**  
(screw coupling)

#### SP Series

Connectors with solder contacts.

#### SP-SE Series

Connectors with removable crimp contacts and retention clip.

Connectors with removable crimp contacts and contact retainer.

#### PC Series (hermetic)

Connectors with pin contacts and solder connection in hermetically sealed contact inserts (glass fusion).

## Technical data as per MIL-C-26482 G

### Current load single contacts

(when at room temperature and connected to cables with maximum cable cross-section)

Contact size	Nominal current A		Test Current A		Voltage drop at test current mV max.	
	Solder contact/ Crimp contact	Solder contact (hermet.)	Solder contact/ Crimp contact	Solder contact (hermet.)	Solder contact/ Crimp contact	Solder contact (hermet.)
20	7.5	5.0	7.5	5.0	55	70
16	13.0	10.0	13.0	10.0	50	65

### Operating voltage

Voltage class (see contact arrangements pages 8 and 9)	Recommended max. operating voltage (at sea level)		Test voltage (at sea level) AC voltage (eff.) V
	AC voltage (eff.) V	DC voltage V	
I	600	850	1800
II	900	1250	2300

### Flashover voltage over barometric altitude

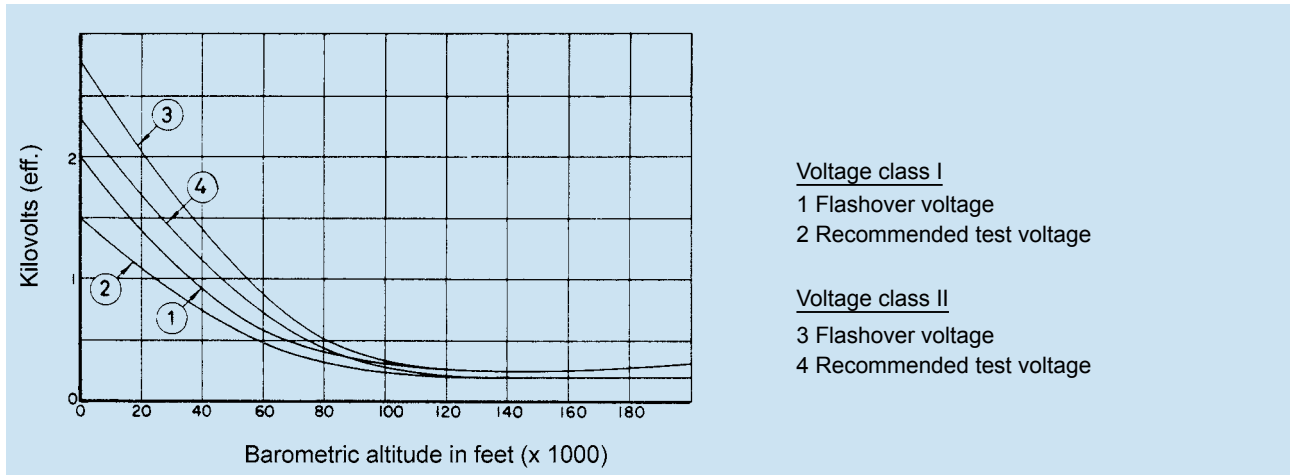

### Operating temperature/insulation resistance

Operating temperature	Insulation resistance
-55° C to +125° C (= ambient temperature + overheating due to current)	$\geq$ 5000 Megohm at 25° C $\geq$ 12 Megohm at 105° C $\geq$ 10 Megohm at 125° C

Current load, ambient and operating temperature as per MIL-C-26482 G § 1.3.1, Fig. 1 B and Table 3/II determine lifetime and areas of use for these connectors.

**Contact information**

Contact size	Dimensions of solder and crimp sleeves			
	Solder connection		Crimp contact	
	Internal- Ø mm	Depth mm	Internal- Ø mm	Depth mm
20	+ 0.10 1.17 0	3.6 ± 0.4	+ 0.05 1.22 0	7.2 ± 0.4
16	+ 0.08 2.00 - 0.07	5.2 ± 0.4	+ 0.05 1.68 0	6.35 ± 0.5

**Connection data**

Contact size	Wire size AWG	Conductor cross-section (mm <sup>2</sup> copper cross-section)	Insulation outer diameter		Strip length crimp contacts mm
			mm min. *	mm max.	
20	24	△ 0.24	1.27	2.29	5 ± 0.5
	22	△ 0.38			
	20	△ 0.62			
16	20	△ 0.62	1.35	2.62	+ 0.5 7 - 1.0
	18	△ 0.96			
	16	△ 1.23			

\*) The minimum insulation diameter is necessary to ensure sufficient moisture protection.

**Coupling torque**

Shell size	Torque max.
8	0.93
10	1.40
12	1.85
14	2.31
16	2.77
18	3.23
20	3.70
22	4.15
24	5.07

**Contact holding force**

Contact size	Load in the axial direction N min.		
20	68		
16	113		

  

**Recommended tightening torque**

Mounting nut of PT 07		Backshell	
Shell size	Torque Nm + 0.5	Shell size	Torque Nm
8	3.6	8	4 + 0.5
10	4.1	10	6 + 0.5
12	5.2	12	8 ± 1.0
14	6.2	14	10 ± 1.0
16	7.3	16	10 ± 1.0
18	9.0	18	13 ± 1.0
20	10.0	20	13 ± 1.0
22	12.4	22	13 ± 1.0
24	13.5	24	13 ± 1.0

## Polarization (coding system)

All connectors have five guide lugs and grooves. If polarization of connectors with the same size and same number of contacts is necessary, this is achieved with different angular positions (W to Z) of the contact insert in relation to the main guide groove.

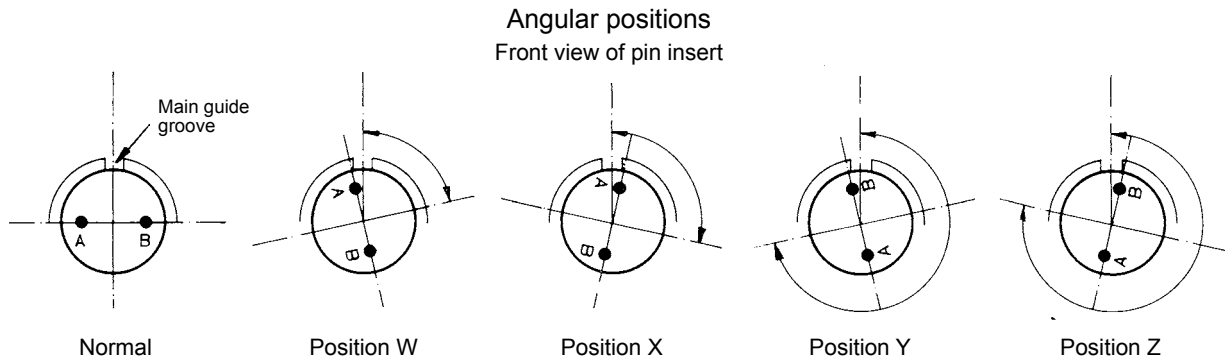

Shell size	Contact arrangement	Angle adjustment in degrees			
		W	X	Y	Z
8	8-2	58	122	–	–
8	8-3	60	210	–	–
8	8-3A*	60	210	–	–
8	8-33	90	–	–	–
8	8-4	45	–	–	–
10	10-6	90	–	–	–
10	10-7	–	–	–	–
10	10-98	90	180	24	270
12	12-3	–	–	180	–
12	12-8	90	112	203	292
12	12-10	60	155	270	295
12	12-14	–	–	–	–
14	14-5	40	92	184	273
14	14-12	43	90	–	–
14	14-15	17	110	155	234
14	14-18	15	90	180	270
14	14-19	30	165	315	–
16	16-8	54	152	180	331
16	16-23	158	270	–	–
16	16-26	60	–	275	338

Shell size	Contact arrangement	Angle adjustment in degrees			
		W	X	Y	Z
18	18-11	62	119	241	340
18	18-30	180	193	285	350
18	18-32	85	138	222	265
20	20-16	238	318	333	347
20	20-24*	70	145	215	290
20	20-25*	72	144	216	288
20	20-27*	72	144	216	288
20	20-39*	63	144	252	333
20	20-41*	45	126	225	–
22	22-21	16	135	175	349
22	22-32*	72	145	215	288
22	22-34*	62	142	218	298
22	22-36*	72	144	216	288
22	22-41*	39	135	264	–
22	22-55*	30	142	226	314
24	24-61	90	160	270	324

\*) These contact arrangements are currently not available for hermetically sealed connectors.

Ordering information page 70



OVERVIEW

Total number of contacts	Contact arrangement	Contact number for each contact size		Contact arrangement					Contact arrangement as per MII and VG		
		20	16	Solder connection	Solder connection hermetic	Crimp connection	PCB connection	Wire-wrap connection	MIL-C-26482		VG 95328*
									Solder connection	Crimp connection	Crimp connection
2	8-2	2		●	●		●	●	●		
3	8-3	3		●	●	●	●	●	●		●
3	8-3A	3		●		●	●	●			●
3	12-3		3	●	●	●			●	●	●
3	8-33	3		●	●	●	●	●	●	●	
4	8-4	4		●	●		●	●	●		
5	14-5		5	●	●	●			●	●	●
6	10-6	6		●	●	●	●	●	●	●	●
6	10-98	6		●	●		●	●	●		
7	10-7	7		●			●	●			
8	12-8	8		●	●	●	●	●			
8	16-8		8	●	●	●			●	●	●
10	12-10	10		●	●	●	●	●	●	●	●
11	18-11		11	●	●	●			●	●	●
12	14-12	8	4	●	●	●			●	●	●
14	12-14	14		●			●	●			
15	14-15	14	1	●	●	●			●	●	●
16	20-16		16	●	●	●			●	●	●
18	14-18	18		●	●	●	●	●			
19	14-19	19		●	●	●	●	●	●	●	●
21	22-21		21	●	●	●			●	●	●
23	16-23	22	1	●	●	●					●
24	20-24	24		●			●	●			
25	20-25	25		●			●	●			
26	16-26	26		●	●	●	●	●	●	●	●
27	20-27	27		●			●	●			
30	18-30	29	1	●	●	●					
32	18-32	32		●	●	●	●	●	●	●	●
32	22-32	32		●		●	●	●			
34	22-34	34		●			●	●			
36	22-36	36		●			●	●			
39	20-39	37	2	●	●	●			●	●	●
41	20-41	41		●	●	●	●	●	●	●	●
41	22-41	27	14	●		●			●	●	●
55	22-55	55		●	●	●	●	●	●	●	●
61	24-61	61		●	●	●	●	●	●	●	●

Additional contact arrangements upon request. These include coaxial, high-voltage, and thermal contacts.

\* Also available with solder connection in style H.

Ordering information page 70

## Contact arrangements

Contact symbols: ● 16 ○ 20

The following images show the front view of the pin insert and the back of the socket insert.

Image (contact arrangement)								
<b>Contact arrangement</b>	<b>8-2*</b>	<b>8-3*</b>	<b>8-3A</b>	<b>8-33</b>	<b>8-4*</b>	<b>10-6</b>	<b>10-7</b>	<b>10-98*</b>
Number of contacts	2	3	3	3	4	6	7	6
Contact size	20	20	20	20	20	20	20	20
Voltage class	I	I	I	I	I	I	I	I
Hermetically sealed	H	H	-	H	H	H	-	H

Image (contact arrangement)					
<b>Contact arrangement</b>	<b>12-3</b>	<b>12-8</b>	<b>12-10</b>	<b>12-14</b>	<b>14-5</b>
Number of contacts	3	8	10	14	5
Contact size	16	20	20	20	16
Voltage class	II	I	I	I	II
Hermetically sealed	H	H	H	-	H

Image (contact arrangement)				
<b>Contact arrangement</b>	<b>14-12</b>	<b>14-15</b>	<b>14-18</b>	<b>14-19</b>
Number of contacts	8 4	14 1	18	19
Contact size	20 16	20 16	20	20
Voltage class	I	I	I	I
Hermetically sealed	H	H	H	H

Image (contact arrangement)				
<b>Contact arrangement</b>	<b>16-8</b>	<b>16-23</b>	<b>16-26</b>	<b>18-11</b>
Number of contacts	8	22 1	26	11
Contact size	16	20 16	20	16
Voltage class	II	I	I	II
Hermetically sealed	H	H	H	H

Ordering information page 70

\*Only available in PT-A and PT-E

Additional contact arrangements upon request

Contact symbols: ● 16 ○ 20











The following images show the front view of the pin insert and the back of the socket insert.

Image (contact arrangement)				
<b>Contact arrangement</b>	<b>18-30</b>	<b>18-32</b>	<b>20-16</b>	
Number of contacts	29 1	32	16	
Contact size	20 16	20	16	
Voltage class	I	I	II	
Hermetically sealed	H	H	H	
Image (contact arrangement)				
<b>Contact arrangement</b>	<b>20-24*</b>	<b>20-25*</b>	<b>20-27*</b>	<b>20-39</b>
Number of contacts	24	25	27	37 2
Contact size	20	20	20	20 16
Voltage class	I	I	I	I
Hermetically sealed	-	-	-	H
Image (contact arrangement)				
<b>Contact arrangement</b>	<b>20-41</b>	<b>22-21</b>	<b>22-32*</b>	<b>22-34*</b>
Number of contacts	41	21	32	34
Contact size	20	16	20	20
Voltage class	I	II	I	I
Hermetically sealed	H	H	-	-
Image (contact arrangement)				
<b>Contact arrangement</b>	<b>22-36*</b>	<b>22-41</b>	<b>22-55</b>	<b>24-61</b>
Number of contacts	36	27 14	55	61
Contact size	20	20 16	20	20
Voltage class	I	I	I	I
Hermetically sealed	-	-	H	H

Ordering information page 70



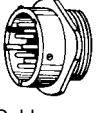
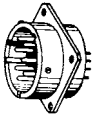

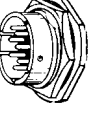
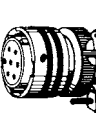
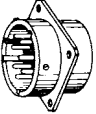
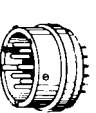



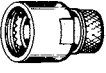

\*Only available in PT-A and PT-E

## PT Series (solder connection, see p. 14-29)

Backshells (See p. 15)	Without backshell	Without special requirements	Without special requirements, with cable clamp	For single wire seals	For single wire seals, with cable clamp	For heat shrink parts	For sealing wire bundles	For sealing wire bundles, with cable clamp	For sealing jacketed cables
									
Shell design		A	A...SR	E	E...SR	E...J	P	P...SR	W
 PT 00 Wall mounting receptacle		●	●	●	●	●	●	●	●
 PT 01 Cable connecting plug		●	●	●	●	●	●	●	●
 PT 02 PT 02 H (hermet.) Box mounting receptacle	● VG 95328 Style H ●								
 PT 06 Straight plug		●	●	●	●	●	●	●	●
 PT 07 PT 07 H (hermet.) Receptacle for single hole mounting	● ● VG 95328 Style F			●*	●*		●	●*	
 PT 08 Angle plug		Backshells see p. 24							
 PTB Thru-bulkhead receptacle	● VG 95328 Style P								
 PTIH (hermet.) Receptacle with solder flange	● VG 95328 Style G								

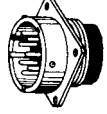
\*) These backshells for PT 07 have an external thread (see page 21)

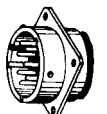
PT-SE Series (solder connection, see p. 39-52)

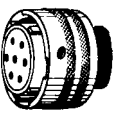
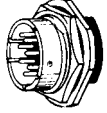
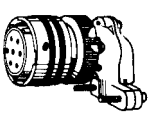
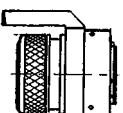
Backshells (See p. 15)	Without backshell	For single wire seals	For single wire seals, with cable clamp	For heat shrink parts (twist-proof)	For heat shrink parts	For shielding braids and heat shrink parts	For sealing wire bundles	For sealing jacketed and shielded cables
	Shell design							
	SE	SE ... SR	SE ... F	SE ... J	SE ... SQ	SP	PG ...	
 PT 00 Wall mounting receptacle		● VG 95328 Style A	● VG 95328 Style B		●	● VG 95328 Style R	●	●
 PT 01 Cable connecting plug		●	●		●	●	●	●
 PT 02 Box mounting receptacle	● VG 95328 Style C							
 PT 06 Straight plug		●	● VG 95328 Style K	●	● VG 95328 Style J		●	●
 PT 06* Wall mounting receptacle (HF-sealed)						● VG 95328 Style M		●
 PT 07 Receptacle for single hole mounting		● ** VG 95328 Style D	● ** VG 95328 Style E			● *** VG 95328 Style T	● **	● **
 PT 08 Angle plug		Backshells see p. 51						
	● VG 95328 Style U	Technical specifications see p. 50						

\*) The PTG plug (G = grounding fingers) is equipped with a grounding ring to ensure 360° HF-sealing and a low coupling resistance between plug and receptacle shell. The plug is only available with backshells SE... PGV, and SE ... SQ (see p. 49 and 50).

\*\*\*) These backshells for PT 07 have an external thread (see page 46).

\*\*\*\*) Backshells for PT 07 with internal threads as with VG 95328 Style M (see p 50).

## Cross-reference table

### PT Series (solder connection)

Connectors	PT designation	MS designation (MIL-C-26482)	VG designation (VG 95328)
Wall mounting receptacle	PT 00 A	- - -	-
	PT 00 A SR	- - -	-
	PT 00 C	- - -	-
	PT 00 E	MS 3110 E	-
	PT 00 E SR	MS 3110 F	-
	PT 00 E J	- - -	-
	PT 00 P	MS 3110 P	-
	PT 00 P SR	- - -	-
	PT 00 W	- - -	-
Cable connecting plug	PT 01 A	- - -	-
	PT 01 A SR	- - -	-
	PT 01 E	MS 3111 E	-
	PT 01 E SR	MS 3111 F	-
	PT 01 E J	- - -	-
	PT 01 P	MS 3111 P	-
	PT 01 P SR	- - -	-
	PT 01 W	- - -	-
Box mounting receptacle	PT 02 A	- - -	-
	PT 02 C	- - -	Style H
	PT 02 E	MS 3112 E	-
	PT 02 H	MS 3112 H	-
Straight plug	PT 06 A	- - -	-
	PT 06 A SR	- - -	-
	PT 06 E	MS 3116 E	-
	PT 06 E SR	MS 3116 F	-
	PT 06 E J	- - -	-
	PT 06 P	MS 3116 P	-
	PT 06 P SR	- - -	-
	PT 06 W	- - -	-
Receptacle for single hole mounting	PT 07 A	- - -	-
	PT 07 C	- - -	-
	PT 07 E	MS 3114 E	-
	PT 07 E SR	MS 3114 F	-
	PT 07 P	MS 3114 P	-
	PT 07 P SR	- - -	-
	PT 07 H	MS 3114 H	Style F
Angle plug	PT 08 E	- - -	-
	PT 08 P	- - -	-
Thru-bulkhead receptacle	PTB	MS 3119	Style P
Receptacle with solder flange	PTIH	MS 3113 H	Style G

Cross-reference example with the contact arrangement of 18 - 32 and pin contacts P

PT 02 E 18-32 P = MS 3112 E 18-32 P = VG 95328 H 18-32 P

**PT-SE Series (crimp connection)**

Connectors	PT designation	MS designation (MIL-C-26482)	VG designation (VH 95328)
Wall mounting receptacle	PT 00 SE PT 00 SE SR PT 00 SE J PT 00 SP PT 00 SE PG PT 00 SE SQ	MS 3120 E MS 3120 F - - - MS 3120 P - - - - - -	Style A Style B - - - Style R
Cable connecting plug	PT 01 SE PT 01 SE SR PT 01 SE J PT 01 SP PT 01 SE PG	MS 3121 E MS 3121 F - - - MS 3121 P - - -	- - - - -
Box mounting receptacle	PT 02 SE	MS 3122 E	Style C
Straight plug	PT 06 SE PT 06 SE SR PT 06 SE F PT 06 SE J PT 06 SP PT 06 SE PG	MS 3126 E MS 3126 F - - - - - - MS 3126 P - - -	- Style K - Style J - -
Straight plug (HF-sealed)	PTU 06 SE SQ PTG 06 SE N PTG 06 SE SQ PTG 06 SE PG	- - - - - - - - - - - -	Style U - Style M -
Receptacle for single hole mounting	PT 07 SE PT 07 SE SR PT 07 SE SQ PT 07 SP PT 07 SE PG	MS 3124 E MS 3124 F - - - MS 3124 P - - -	Style D Style E Style T - -
Angle plug	PT 08 SE PT 08 SP	- - - - - -	- -

**PT-GS and PT-WW Series (PCB and wire-wrap connection)**

Connectors	PT designation	MS designation (MIL-C-26482)	VG designation (VG 95328)
Box mounting receptacle	PT 02 GS PT 02 WW	- - - - - -	- -
Receptacle for single hole mounting	PT 07 GS PT 07 WW	- - - - - -	- -

Cross-reference example with the contact arrangement of 18 - 32 and socket contacts S

PT 02 SE 18-32 S = MS 3122 E 18-32 S = VG 95328 C 18-32 S

## PT Series

Solder connection

The PT series includes the following types of plugs and receptacles with non-removable solder contacts, which are attachable to and interchangeable with all the connectors of the MIL-C-26482, VG 95328, LN 29500, LN 29504, MIL-C-83723, NAS 1599, NFL 54125, DEF 5325-3/5326-3 and IEC publication 130-7 standards.

The connectors in this series, which can be delivered with different backshells depending on service class (see page 15), are specified in accordance with MIL-C-26482, Series 1 (see page 12).

### Design features

#### Shell

- Aluminum alloy.
- Surface treatment: cadmium and green chromate coating; conductive = standard. Other surfaces: see p. 70
- Three pin bayonet coupling.
- 5 guide grooves and lugs for perfect coupling.
- Up to 5 angular positions ensure polarization of the contact insert and main guide groove.
- 8 shell designs (see p. 16 to 29).
- 9 shell sizes (size 8 to 24).
- Sealing elements on mating and termination face (excluding service class "A"). Protection class IEC 529: IP 67 depending on backshell.

#### Contact insert

- Neoprene insert.
- Numerous contact arrangements with 2 to 61 contacts.
- Contact designation on mating and termination face.

#### Solder contacts

- Pin and socket contacts made of high-quality copper alloy.
- Hard gold plated contact surface.
- Contact sizes AWG 16 and 20 (see page 5).
- Pin and socket contacts are non-removable.

Ordering information page 70



**PT 00**  
Wall mounting  
receptacle



**PT 01**  
Cable connecting  
plug



**PT 02**  
Box mounting  
receptacle



**PT 06**  
Straight plug



**PT 07**  
Receptacle for  
single hole mounting



**PTB**  
Thru-bulkhead  
receptacle

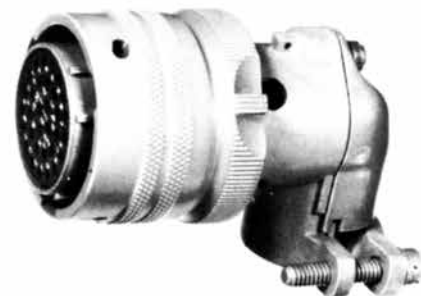

**PT 08**  
Angle plug





## Service classes and backshells

PT connectors are available in six service classes to meet different environmental requirements. There are one or two backshells for each service class, with the exception of "C" and "H".

### Service classes

Service class	Characteristics	Service class	Characteristics
»A«	Without special requirements	»P«	Similar to service class »E«, yet for sealing wire bundles.
»C«	Pressure-proof version. Only for receptacles. Air leakage % $4.55 \times 10^{-3} \text{ cm}^3/\text{s}$ at 1 bar positive pressure.	»W«	Similar to service class »E«, yet for sealing jacketed multi-conductor cables.
»E«	Moisture-proof version. Receptacle pressure-proof to 0.1 bar positive pressure. Single wire seal	»H«	Hermetically sealed version. Helium leakage % $1 \times 10^{-6} \text{ cm}^3/\text{s}$ at 1 bar.

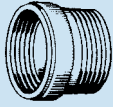
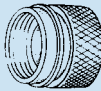
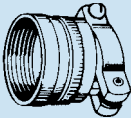
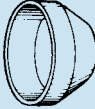
### Backshells

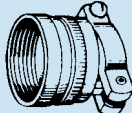
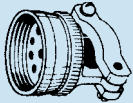
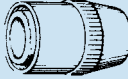
Backshells	Characteristics	Backshells	Characteristics
 A	Backshell for applications without special requirements.	 E ... J	Backshell for attaching heat shrink parts (see p. 60)
 A ... SR	Backshell with cable clamp for applications without special requirements.	 P	Nylon potting boot for sealing open wires.
 E	Backshell with insert for single wire sealing.	 P ... SR	Backshell with cable clamp for sealing wire bundles.
 E ... SR	Backshell with sealing insert and cable clamp for single wire sealing	 W	Neoprene gland for sealing jacketed multi-conductor cables.

### Available connectors

Connector	Service class					
	»A«	»C«	»E«	»P«	»W«	»H«
Wall mounting receptacle	PT 00 A	PT 00 C	PT 00 E	PT 00 P	PT 00 W	— — —
Cable connecting plug	PT 01 A	— — —	PT 01 E	PT 01 P	PT 01 W	— — —
Box mounting receptacle*	PT 02 A	PT 02 C	PT 02 E	— — —	PT 02 W	PT 02 H
Straight plug	PT 06 A	— — —	PT 06 E	PT 00 P	PT 06 W	— — —
Receptacle for single hole mounting	PT 07 A	PT 07 C	PT 07 E	PT 01 P	— — —	PT 07 H
Angle plug	— — —	— — —	PT 08 E	PT 02 P	— — —	— — —
Thru-bulkhead receptacle	— — —	PTB	— — —	— — —	— — —	— — —
Receptacle with solder flange	— — —	— — —	— — —	— — —	— — —	PTIH

\*) The PT 02 receptacle is available in the named service classes, but cannot be equipped with a backshell.

## Wall mounting receptacle PT 00 (MS 3110)

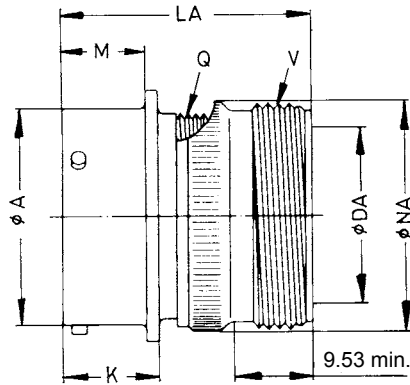

**PT 00 A**  
**PT 00 C**

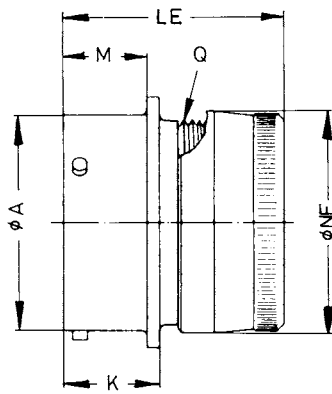
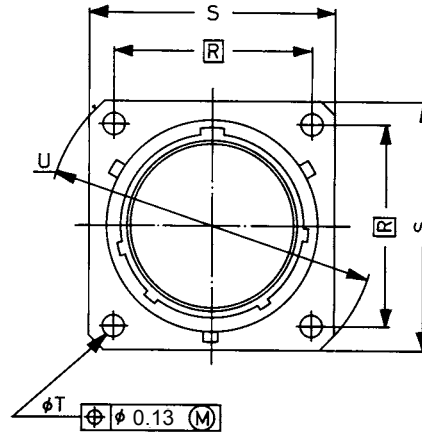

**PT 00 E**  
(MS 3110 E)

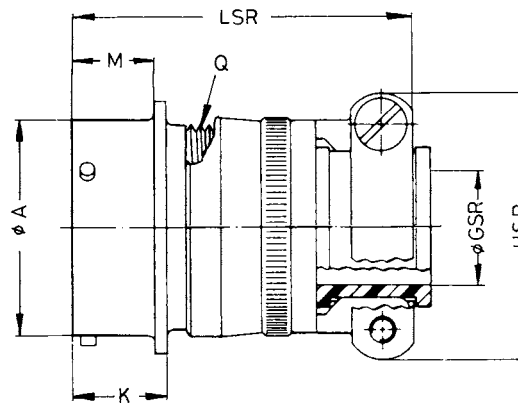

**PT 01 A ... SR**  
**PT 01 E ... SR (MS 3110 F)**  
**PT 01 P ... SR**

Ordering example PT 00 E 14-19 S W SR see p. 70

Dimensions in mm

Shell size	Ø A	Ø DA	Ø GSR	HSR	K	LA	LE	LSR	M	Ø NA	Ø NE	Thread Q	R	S	Ø T	U	Thread V
	+0.03 -0.13	min.	±0.25	max.	+0.64 -0.25	max.	max.	max.	+0.25 0	max.	max.	Class 2 A (inch)	Theoret. dimensions	max.	±0.13	±0.41	Class 2 A (inch)
8	12.01	7.54	3.18	21.02	12.52	39.5	32.70	48.82	10.95	14.99	14.22	0.4375-28 UNEF	15.09	21.02	3.05	26.97	0.5000-28 UNEF
10	14.99	10.69	4.78	22.63	12.52	39.5	32.70	48.82	10.95	18.21	17.40	0.5625-24 NEF	18.26	24.23	3.05	31.75	0.6250-24 NEF
12	19.05	13.87	7.92	25.81	12.52	39.5	32.70	48.82	10.95	21.18	20.65	0.6875-24 NEF	20.62	26.59	3.05	34.93	0.7500-20 UNEF
14	22.23	16.84	9.53	28.98	12.52	39.5	32.70	48.82	10.95	24.64	23.62	0.8125-20 UNEF	23.01	28.98	3.05	38.10	0.8750-20 UNEF
16	25.40	19.99	12.70	30.56	12.52	39.5	32.70	50.80	10.95	27.64	26.85	0.9375-20 UNEF	24.61	31.34	3.05	41.28	1.0000-20 UNEF
18	28.58	22.33	15.88	37.31	12.52	39.5	32.70	50.80	10.95	30.89	29.85	1.0625-18 NEF	26.97	33.73	3.05	44.45	1.1875-18 NEF
20	31.75	25.76	15.88	37.31	16.51	42.6	38.51	55.17	14.12	33.83	33.05	1.1875-18 NEF	29.36	36.91	3.05	47.63	1.1875-18 NEF
22	34.93	28.80	19.05	42.06	16.51	42.6	38.51	55.17	14.12	37.08	36.32	1.3125-18 NEF	31.75	40.08	3.05	50.80	1.4375-18 NEF
24	38.10	31.98	20.32	44.45	17.35	44.1	40.08	56.74	14.96	40.31	39.50	1.4375-18 NEF	34.93	43.26	3.73	55.58	1.4375-18 NEF

Assembly instructions p. 60-68.

## Wall mounting receptacle PT 00 (MS 3110)

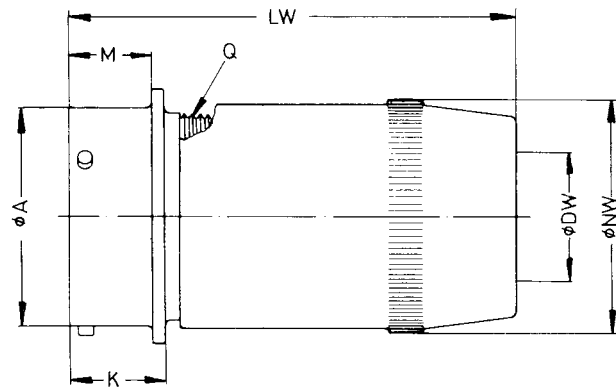
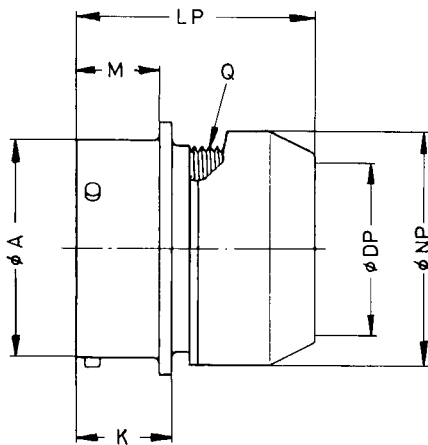
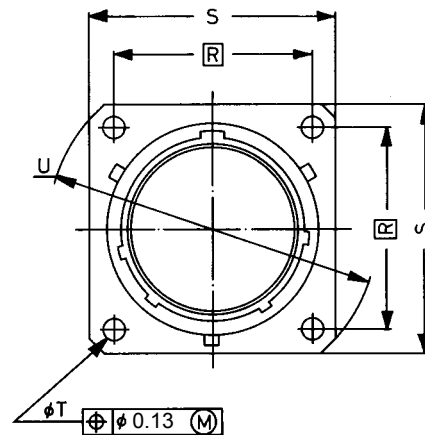
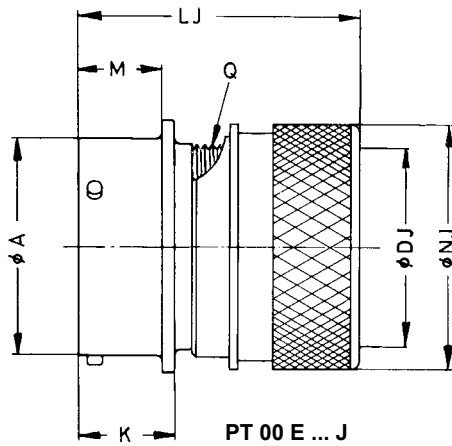

Ordering example PT 00 P 14-19 P W see p. 70

Dimensions in mm

Shell size	Ø A	Ø DJ	Ø DP		Ø DW		K	LJ	LP	LW	M	Ø NJ	Ø NP	Ø NW	Thread Q	R Theoret. dimensions	S	Ø T	U
	+0.03 -0.13	±0.1	min.	min.	max.	+0.64 -0.25													
8	12.01	6.7	8.05	4.27	5.84	12.52	37	36.53	43.31	10.95	14.22	15.44	15.09	0.4375-28 UNEF	15.09	21.02	3.05	26.97	
10	14.99	9.2	11.02	5.21	7.92	12.52	37	36.53	43.31	10.95	17.40	18.64	18.26	0.5625-24 NEF	18.26	24.23	3.05	31.75	
12	19.05	12.0	13.92	8.59	11.23	12.52	37	36.53	46.94	10.95	20.65	21.79	20.62	0.6875-24 NEF	20.62	26.59	3.05	34.93	
14	22.23	15.1	17.09	10.57	13.69	12.52	37	36.53	51.82	10.95	24.5	24.99	23.88	0.8125-20 UNEF	23.01	28.98	3.05	38.10	
16	25.40	18.3	20.27	13.97	15.65	12.52	40	36.53	57.30	10.95	29.8	28.19	27.10	0.9375-20 UNEF	24.61	31.34	3.05	41.28	
18	28.58	19.9	22.83	15.24	17.07	12.52	40	36.53	63.14	10.95	32.0	31.34	30.33	1.0625-18 NEF	26.97	33.73	3.05	44.45	
20	31.75	23.0	26.01	16.13	18.97	16.51	47.5	42.06	72.70	14.12	36.1	34.54	33.58	1.1875-18 NEF	29.36	36.91	3.05	47.63	
22	34.93	25.7	29.18	17.02	21.49	16.51	47.5	42.06	78.38	14.12	38.5	37.69	36.80	1.3125-18 NEF	31.75	40.08	3.05	50.80	
24	38.10	28.6	32.36	18.80	22.71	17.35	47.5	43.61	84.07	14.96	41.5	40.89	40.03	1.4375-18 NEF	34.93	43.26	3.73	55.58	

Assembly instructions p. 60-68.

## Cable connecting plug PT 01 (MS 3111)

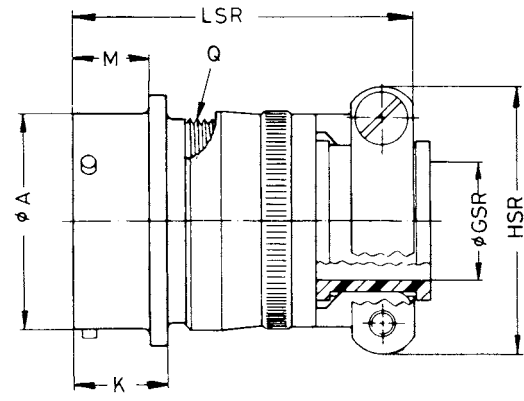
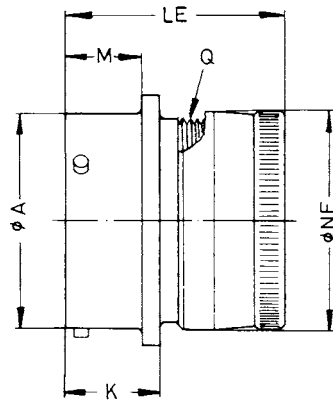
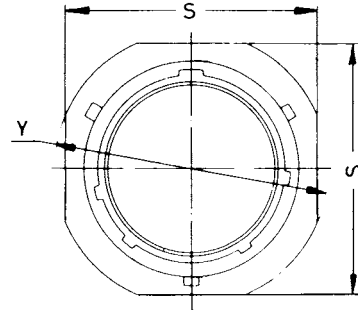
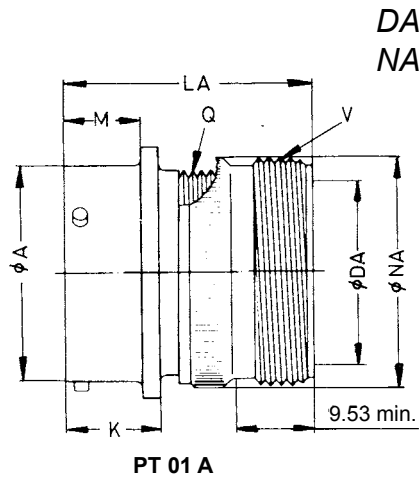

Ordering example PT 01 E 14-19 S W SR see p. 70

### Dimensions in mm

Shell size	$\varnothing A$	$\varnothing DA$	$\varnothing GSR$	HSR	K	LA	LE	LSR	M	$\varnothing NA$	$\varnothing NE$	Thread Q	S	Thread V	Y
	+0.03 -0.13	min.	$\pm 0.25$	max.	+0.64 -0.25	max.	max.	max.	+0.41 0	max.	max.	Class 2 A (inch)	max.	Class 2 A (inch)	$\pm 0.51$
8	12.01	7.54	3.18	21.02	12.55	39.5	32.70	48.82	10.16	14.99	14.22	0.4375-28 UNEF	21.02	0.5000-28 UNEF	23.83
10	14.99	10.69	4.78	22.63	12.55	39.5	32.70	48.82	10.16	18.21	17.40	0.5625-24 NEF	24.23	0.6250-24 NEF	26.97
12	19.05	13.87	7.92	25.81	12.55	39.5	32.70	48.82	10.16	21.18	20.65	0.6875-24 NEF	26.59	0.7500-20 UNEF	29.36
14	22.23	16.84	9.53	28.98	12.55	39.5	32.70	48.82	10.16	24.64	23.62	0.8125-20 UNEF	28.98	0.8750-20 UNEF	31.75
16	25.40	19.99	12.70	30.56	12.55	39.5	32.70	50.80	10.16	27.64	26.85	0.9375-20 UNEF	31.34	1.0000-20 UNEF	34.14
18	28.78	22.33	15.88	37.31	12.55	39.5	32.70	50.80	10.16	30.89	29.85	1.0625-18 NEF	33.73	1.1875-18 NEF	36.53
20	31.75	25.76	15.88	37.31	16.51	42.6	38.51	55.17	13.59	33.83	33.05	1.1875-18 NEF	36.91	1.1875-18 NEF	39.67
22	34.93	28.80	19.05	42.06	16.51	42.6	38.51	55.17	13.59	37.08	36.32	1.3125-18 NEF	40.08	1.4375-18 NEF	42.88
24	38.10	31.98	20.32	44.45	17.35	44.1	40.08	56.74	14.43	40.31	39.50	1.4375-18 NEF	43.26	1.4375-18 NEF	46.02

Assembly instructions p. 60-68.

## Cable connecting plug PT 01 (MS 3111)

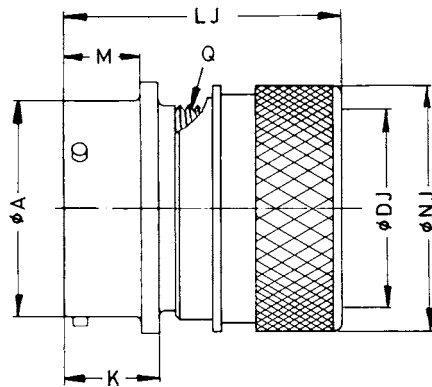

PT 01 E ... J

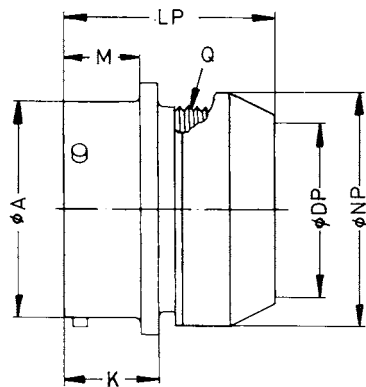
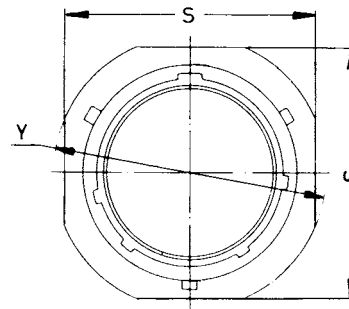

PT 01 P (MS 3111 P)

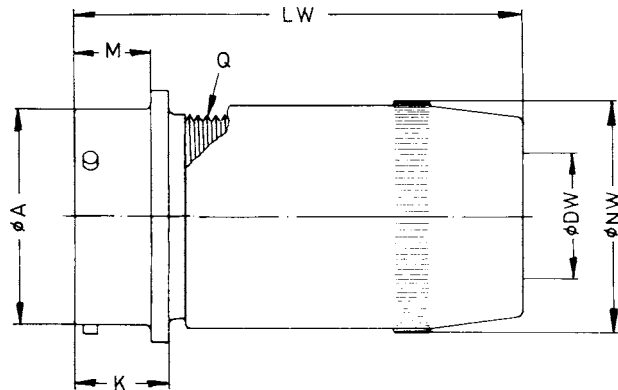

PT 01 W

Ordering example PT 01 W 14-19 P X see p. 70

Dimensions in mm

Shell size	Ø A	Ø DJ	Ø DP	Ø DW		K	LJ	LP	LW	M	Ø NJ	Ø NP	Ø NW	Thread Q	S	Y
				min.	max.											
8	12.01	6.7	8.05	4.27	5.84	12.52	37	36.53	43.31	10.16	15.60	15.44	13.89	0.4375-28 UNEF	21.02	23.83
10	14.99	9.2	11.02	5.21	7.92	12.52	37	36.53	43.31	10.16	18.40	18.64	17.15	0.5625-24 NEF	24.23	26.97
12	19.05	12.0	13.92	8.59	11.23	12.52	37	36.53	46.94	10.16	23.70	21.79	20.64	0.6875-24 NEF	26.59	29.36
14	22.23	15.1	17.09	10.57	13.69	12.52	37	36.53	51.82	10.16	24.5	24.99	23.88	0.8125-20 UNEF	28.98	31.75
16	25.40	18.3	20.27	13.97	15.65	12.52	40	36.53	57.30	10.16	29.8	28.19	27.10	0.9375-20 UNEF	31.34	34.14
18	28.78	19.9	22.83	15.24	17.07	12.52	40	36.53	63.14	10.16	32.0	31.34	30.33	1.0625-18 NEF	33.73	36.53
20	31.75	23.0	26.01	16.13	18.97	16.51	47.5	42.06	74.22	13.59	36.1	34.54	33.58	1.1875-18 NEF	36.91	39.67
22	34.93	25.7	29.18	17.02	21.49	16.51	47.5	42.06	78.38	13.59	38.5	37.69	36.80	1.3125-18 NEF	40.08	42.88
24	38.10	28.6	32.36	18.80	22.71	17.35	47.5	43.61	84.07	14.43	41.5	40.89	40.03	1.4375-18 NEF	43.26	46.02

Assembly instructions p. 60-68.

## Box mounting receptacle PT 02 (VG 95328)

The receptacle PT 02 is available in the service classes A, C, E and H (see page 15), but cannot be equipped with a backshell, as there is no thread for this.

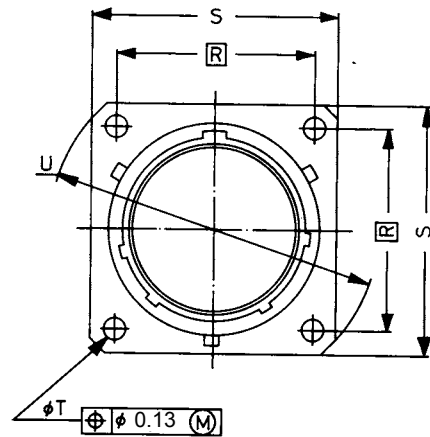
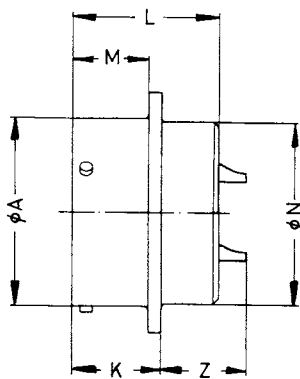

**PT 02 A**  
**PT 02 C**  
**PT 02 E** (VG 95328 H / MS 3112 E)

Ordering example PT 02 C 14-19 S W see p. 70

Dimensions in mm

Housing size	Ø A	K	L	M	Ø N	$\boxed{R}$	S	T	U	Z
	+0.03 -0.13	+0.64 -0.25	max.	+0.25 0	max.	Theoret. dimensions	max.	±0.13	±0.41	max.
8	12.01	12.52	20.96	10.95	11.40	15.09	21.02	3.05	26.97	11.81
10	14.99	12.52	20.96	10.95	14.55	18.26	24.23	3.05	31.75	11.81
12	19.05	12.52	20.96	10.95	17.75	20.62	26.59	3.05	34.93	11.81
14	22.23	12.52	20.96	10.95	20.90	23.01	28.98	3.05	38.10	11.81
16	25.40	12.52	20.96	10.95	24.10	24.61	31.34	3.05	41.28	11.81
18	28.58	12.52	20.96	10.95	27.25	26.97	33.73	3.05	44.45	11.81
20	31.75	16.51	27.33	14.12	30.45	29.36	36.91	3.05	47.63	13.36
22	34.93	16.51	27.33	14.12	33.60	31.75	40.08	3.05	50.80	13.36
24	38.10	17.35	28.17	14.96	36.80	34.93	43.26	3.73	55.58	12.52

Assembly instructions p. 60-68.

## Receptacle for single hole mounting PT 07 (MS 3114)

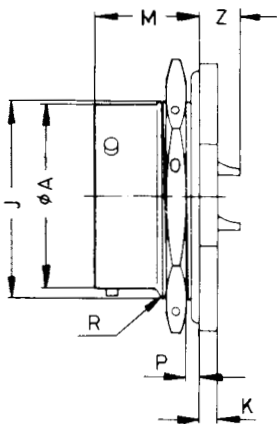

PT 07 A  
PT 07 C

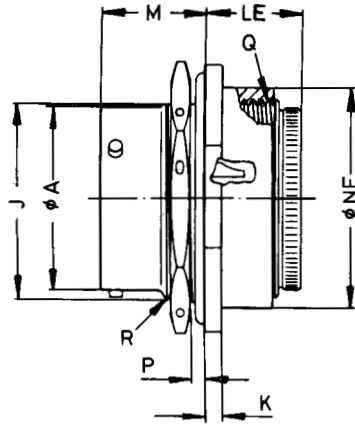

PT 07 E  
(MS 3114 E)

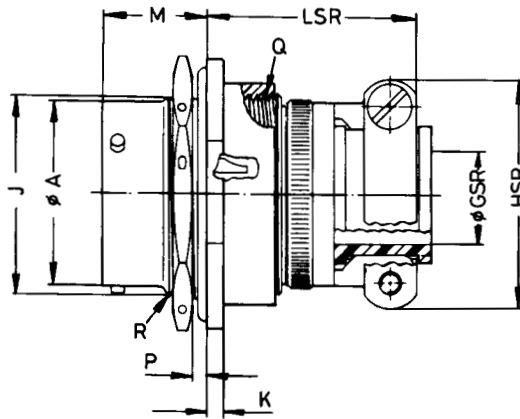
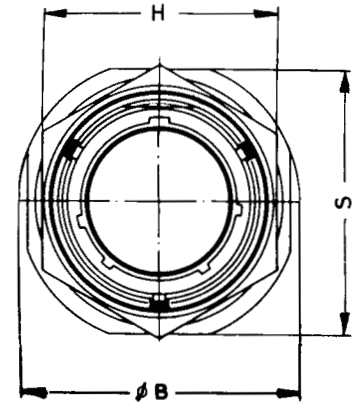

PT 07 E ... SR (MS 3114 F)  
PT 07 P ... SR

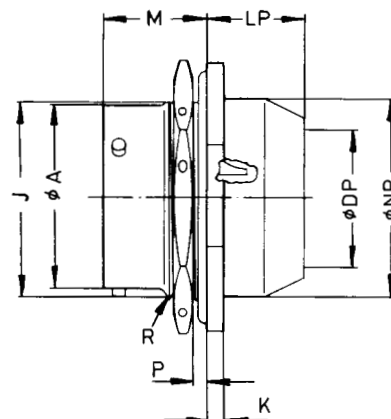

PT 07 P  
(MS 3114 P)

Ordering example PT 07 E 14-19 S W SR see p. 70

### Dimensions in mm

Shell size	$\varnothing A$	$\varnothing B$	$\varnothing DP$	$\varnothing GSR$	H	HSR	J	K	LE	LP	LSR	M	$\varnothing NE$	$\varnothing NP$	P		Thread Q	Thread R	S	Z
	+0.03 -0.13	max.	min.	$\pm 0.25$	$\pm 0.4$	max.	0 -0.25	+0.28 -0.25	max.	max.	max.	$\pm 0.13$	max.	max.	min.	max.	Class 2 B (inch)	Class 2 A (inch)	max.	$\pm 1.02$
8	12.01	27.5	8.05	3.18	19.1	21.02	13.46	3.18	17.19	16.89	31.14	17.68	18.52	15.44	1.6	3.2	0.6250-24 NEF	0.5625-24 NEF	24.24	4.85
10	14.99	30.5	11.02	4.78	22.2	22.63	16.64	3.18	17.19	16.89	31.14	17.68	21.69	18.64	1.6	3.2	0.7500-20 UNEF	0.6875-24 NEF	27.38	4.85
12	19.05	35.5	13.92	7.92	27.0	25.81	20.78	3.18	17.19	16.89	31.14	17.68	24.87	21.79	1.6	3.2	0.8750-20 UNEF	0.8750-20 UNEF	32.16	4.85
14	22.23	38.5	17.09	9.53	30.2	28.98	23.93	3.18	17.19	16.89	31.14	17.68	23.04	24.99	1.6	3.2	1.0000-20 UNEF	1.0000-20 UNEF	35.33	4.85
16	25.40	41.5	20.27	12.70	33.3	30.56	27.08	3.18	17.19	16.89	33.12	17.68	31.22	28.19	1.6	3.2	1.1250-18 NEF	1.1250-18 NEF	38.51	4.85
18	28.58	45.0	22.83	15.88	36.5	37.31	30.25	3.18	17.19	16.89	33.12	17.68	34.39	31.34	1.6	3.2	1.2500-18 NEF	1.2500-18 NEF	41.68	4.85
20	31.75	49.5	26.01	15.88	39.7	37.31	33.43	3.96	18.62	20.07	33.72	22.45	38.35	34.54	1.6	3.2	1.3750-18 NEF	1.3750-18 NEF	46.43	5.61
22	34.93	52.5	29.18	19.05	42.9	42.06	36.60	3.96	18.62	20.07	33.72	22.45	41.53	37.69	1.6	3.2	1.5000-18 NEF	1.5000-18 NEF	49.63	5.61
24	38.10	56.0	32.36	20.32	46.0	44.45	39.78	3.96	19.38	20.07	34.53	23.29	44.70	40.89	1.6	3.2	1.6250-18 NEF	1.6250-18 NEF	52.78	4.78

Assembly instructions p. 60-68.

## Straight plug PT 06 (MS 3116)

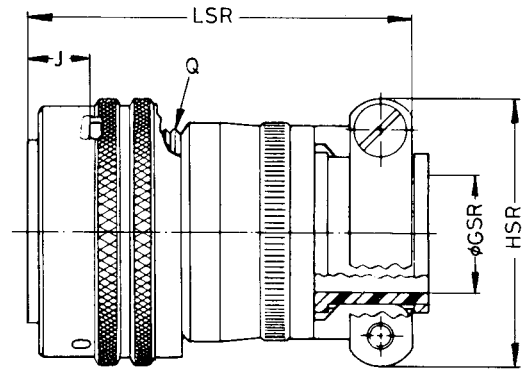
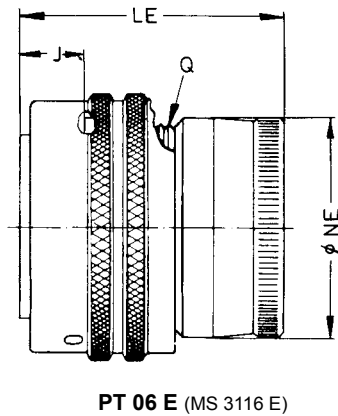
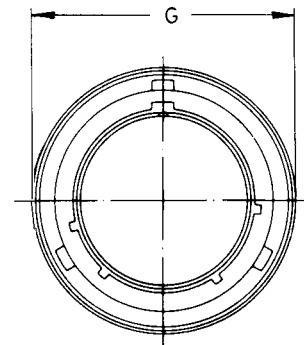
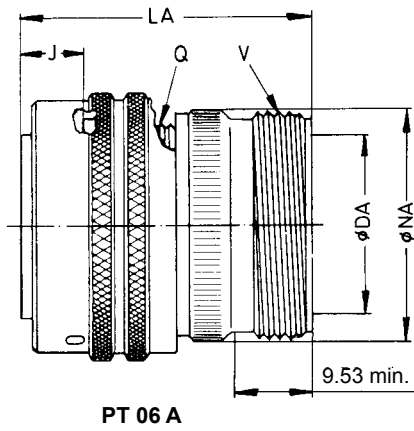

Ordering example PT 06 A 14-19 P W see p. 70

### Dimensions in mm

Shell size	$\phi DA$	$\phi G$	$\phi GSR$	HSR	J	LA	LE	LSR	$\phi NA$	$\phi NE$	Thread Q	Thread V
	min.	max.	$\pm 0.25$	max.	$\pm 0.25$	max.	max.	max.	max.	max.	Class 2 A (inch)	Class 2 A (inch)
8	7.54	19.05	3.18	21.02	8.97	40.87	32.16	48.82	14.99	14.22	0.4375-28 UNEF	0.5000-28 UNEF
10	10.69	21.82	4.78	22.63	8.97	40.87	32.16	48.82	18.21	17.40	0.5625-24 NEF	0.6250-24 NEF
12	13.87	26.19	7.92	25.81	8.97	40.87	32.16	48.82	21.18	20.65	0.6875-24 NEF	0.7500-20 UNEF
14	16.84	29.36	9.53	28.98	8.97	40.87	32.16	48.82	24.64	23.62	0.8125-20 UNEF	0.8750-20 UNEF
16	19.99	32.54	12.70	30.56	8.97	40.87	32.16	50.80	27.64	26.85	0.9375-20 UNEF	1.0000-20 UNEF
18	22.33	35.33	15.88	37.31	8.97	40.87	32.16	50.80	30.89	29.85	1.0625-18 NEF	1.1875-18 NEF
20	25.76	38.89	15.88	37.31	10.54	42.06	36.53	53.57	33.83	33.05	1.1875-18 NEF	1.1875-18 NEF
22	28.80	42.06	19.05	42.06	10.54	42.06	36.53	53.57	37.08	36.32	1.3125-18 NEF	1.4375-18 NEF
24	31.98	45.14	20.32	44.45	10.54	44.45	38.10	55.17	40.31	39.50	1.4375-18 NEF	1.4375-18 NEF

Assembly instructions p. 60-68.



## Straight plug PT 06 (MS 3116)

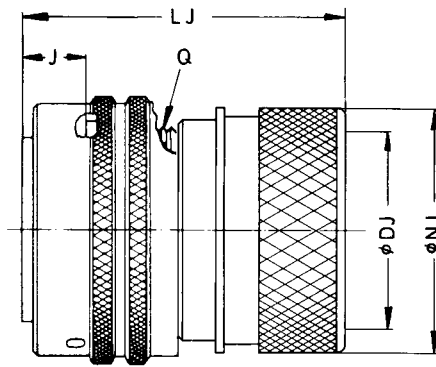

PT 06 E ... J

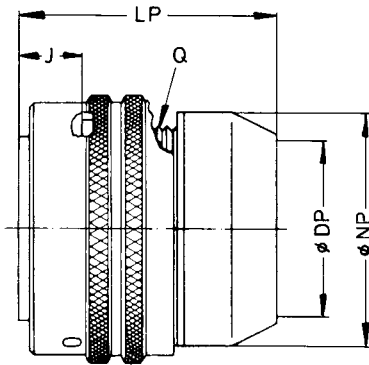
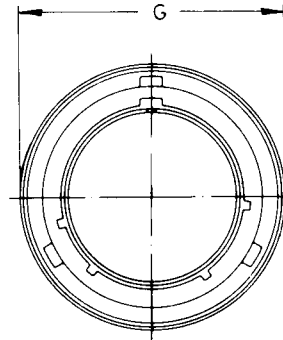

PT 06 P (MS 3116 P)

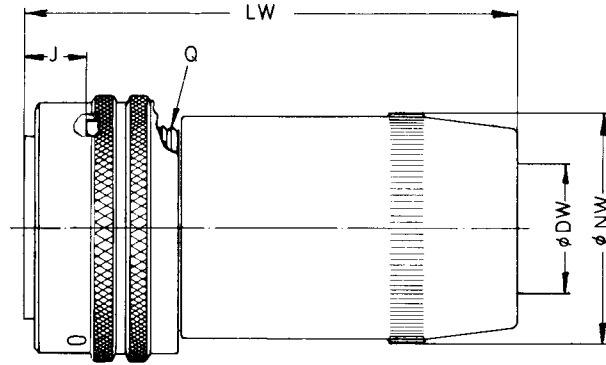

PT 06 W

Ordering example

PT 06 E 14-19 P W J

see p. 70

### Dimensions in mm

Shell size	φ DJ	φ DP	φ DW		G	J	LJ	LP	LW	φ NJ	φ NP	φ NW	Thread Q Class 2 A (inch)
	±0.1	min.	min.	max.	max.	max.	max.	max.	max.	max.	max.	max.	
8	6.7	8.05	4.27	5.84	19.05	8.97	37	38.76	43.31	15.6	15.44	13.89	0.4375-28 UNEF
10	9.2	11.02	5.20	7.92	21.82	8.97	37	38.76	43.31	18.4	18.64	17.15	0.5625-24 NEF
12	12.0	13.92	8.59	11.23	26.19	8.97	37	38.76	46.94	23.7	21.79	20.64	0.6875-24 NEF
14	15.1	17.09	10.57	13.70	29.36	8.97	37	38.76	51.82	24.5	24.99	23.88	0.8125-20 UNEF
16	18.3	20.27	13.97	15.65	32.54	8.97	39	38.76	57.30	29.8	28.19	27.10	0.9375-20 UNEF
18	19.9	22.83	15.20	17.10	35.33	8.97	39	38.76	63.14	32.0	31.34	30.33	1.0625-18 NEF
20	23.0	26.01	16.10	19.00	38.89	10.54	47.5	39.27	72.24	36.1	34.54	33.58	1.1875-18 NEF
22	25.7	29.18	17.00	21.50	42.06	10.54	47.5	39.27	76.20	38.5	37.69	36.80	1.3125-18 NEF
24	28.6	32.36	18.80	22.71	45.14	10.54	47.5	42.06	81.53	41.5	40.89	40.03	1.4375-18 NEF

Assembly instructions p. 60-68.

## Angle plug PT 08

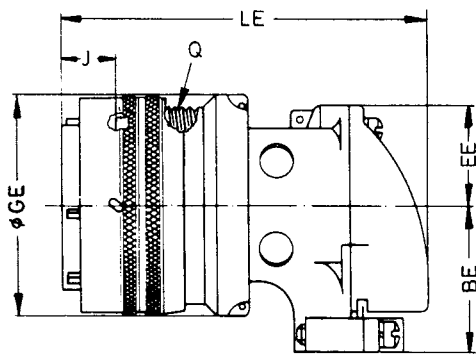

PT 08 E

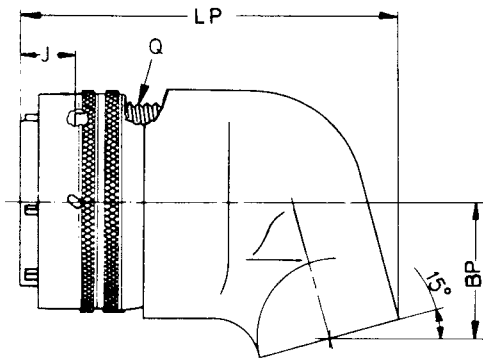
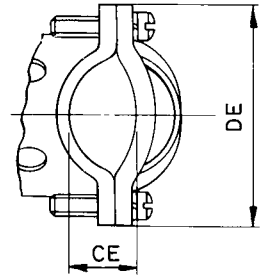
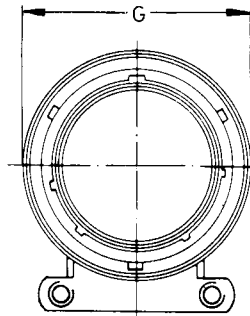

PT 08 P

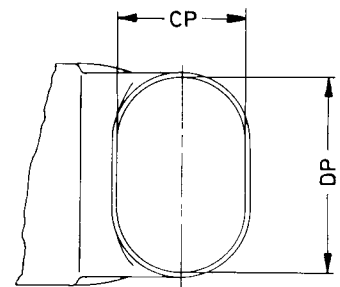
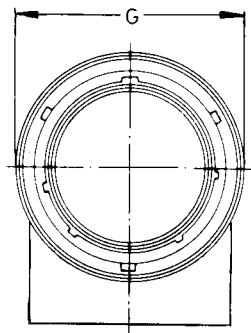

Ordering example PT 08 E 14-19 P W see p. 70

### Dimensions in mm

Shell size	BE	BP	CE	CP	DE	DP	EE	G	øGE	J	LE	LP	Thread Q
	±0.79	max.	+0.25 -0.64	±0.38	±1.57	±0.38	+1.19 -0.64	max.	max.	±0.25	max.	max.	Class 2 A (inch)
8	16.64	11.00	3.96	7.92	23.90	11.13	8.61	19.05	20.21	8.97	53.00	47.0	0.4375-28 UNEF
10	19.02	12.52	4.32	11.13	30.25	14.27	9.98	21.82	23.39	8.97	55.00	50.0	0.5625-24 NEF
12	20.62	14.02	6.71	13.11	30.25	17.48	11.43	26.19	26.57	8.97	58.00	52.0	0.6875-24 NEF
14	22.99	16.33	7.87	15.88	31.85	19.84	13.18	29.36	29.74	8.97	61.00	55.0	0.8125-20 UNEF
16	26.16	16.71	8.38	16.66	33.43	22.61	14.81	32.54	32.94	8.97	65.33	56.0	0.9375-20 UNEF
18	25.78	17.50	11.28	17.86	39.67	25.40	15.77	35.33	36.12	8.97	69.00	57.0	1.0625-18 NEF
20	27.36	19.05	12.95	19.46	41.28	28.58	17.35	38.89	39.67	10.54	71.00	64.0	1.1875-18 NEF
22	28.93	20.17	13.08	20.62	43.66	31.34	18.77	42.06	42.47	10.54	72.00	65.0	1.3125-18 NEF
24	32.13	27.18	16.66	23.32	44.45	34.90	20.24	45.11	45.64	10.54	78.00	74.0	1.4375-18 NEF

Assembly instructions p. 60-68.

## Thru-bulkhead receptacle PTB (MS 3119)

The PTB thru-bulkhead is pressure-proof in accordance with service class "C" (see p. 15). It is equipped with contact pins (P) and socket contacts (S). The socket contacts are always on the connector side marked "P".

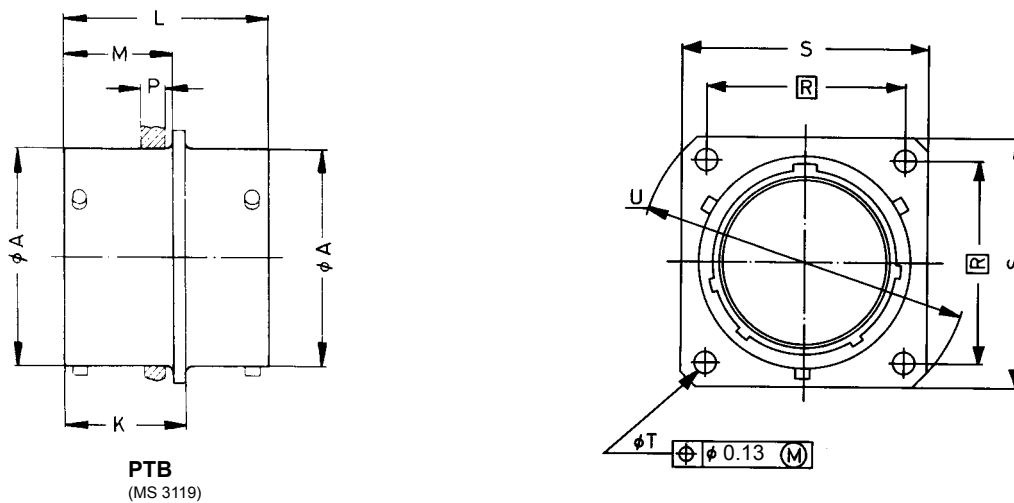

Ordering example      PTB 18-32 PS W      see p. 70

### Dimensions in mm

Shell size	Ø A	K	L	M	P	R	S	Ø T	U
	+0.03 -0.13	+0.41 0	+0.15 -0.13	+0.25 0	max.	Theoretical dimensions	max.	±0.13	±0.41
8	12.01	15.88	26.67	14.27	3.18	15.09	21.02	3.05	26.97
10	14.99	15.88	26.67	14.27	3.18	18.26	24.23	3.05	31.75
12	19.05	15.88	26.67	14.27	3.18	20.62	26.59	3.05	34.93
14	22.23	15.88	26.67	14.27	3.18	23.01	28.98	3.05	38.10
16	25.40	15.88	26.67	14.27	3.18	24.61	31.34	3.05	41.28
18	28.58	15.88	26.67	14.27	3.18	26.97	33.73	3.05	44.45
20	31.75	19.84	33.78	17.48	3.18	29.36	36.91	3.05	47.63
22	34.93	19.84	33.78	17.48	3.18	31.75	40.08	3.05	50.80
24	38.10	19.84	33.78	17.48	3.18	34.93	43.26	3.73	55.58

Assembly instructions p. 60-68.

The PT series also includes hermetically sealed receptacles which are attachable to plugs of the MIL-C-26482, VG 95328, LN 29504, MIL-C-83723, NAS 1599, NFL 54125, DEF 5325-3/5326-3 and IEC-Publication 130-7 standards. These receptacles are available only with pin contacts in the arrangements listed on pages 7 to 9.

Each hermetically sealed socket has a silicone O-ring, which seals the contact insert of the corresponding plug and protects the coupled connector against humidity.

### Design features

- Shell cold-rolled steel, galvanized.
- 9 shell sizes (size 8 to 24).
- 2 to 61 contacts (only pin contacts).
- Contacts made of high-quality nickel alloy, tin-plated.
- Compression glass insert.
- Contacts are labeled on mating and termination face.

### Technical data (see also page 4 and 5)

#### Current load

Contact size 20	5 A max.
Contact size 16	10 A max.

#### Dielectric strength (at sea level)

Voltage class I	1500 V AC voltage (eff.)
Voltage class II	2300 V AC voltage (eff.)

#### Leak rate

1 x 10<sup>-6</sup> cm<sup>3</sup>/s at approx. 1 bar

#### Arc resistance

The dielectric material can withstand the conditions for at least 115 seconds as per MIL-C-5015D.

#### Humidity

Complies with the requirements of MIL-C-5015D and MIL-C-26482

#### Impact

100 g

#### Vibration

Better than MIL-E-5272, Procedure II

#### Operating temperature

-55° C to +125° C  
(= ambient temperature + overheating due to current)

Ordering information page 70

**PT1H**  
Hermetically sealed receptacle with solder flange



**PT 02 H**  
Hermetically sealed receptacle.

**PT 07 H**  
Hermetically sealed receptacle for single hole mounting



## Hermetically sealed receptacle with solder flange PTIH (VG 95328)

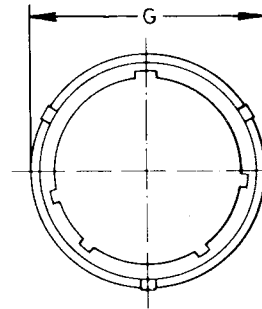
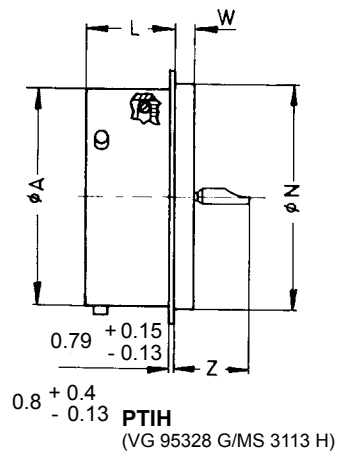

Ordering example      PTIH 18-32 P W      see p. 70

Dimensions in mm

Shell size	$\varnothing A$ $\begin{matrix} +0.025 \\ -0.13 \end{matrix}$	$\varnothing G$ $\pm 0.4$	L $\begin{matrix} +0.64 \\ -0.41 \end{matrix}$	$\varnothing N$ $\begin{matrix} +0.03 \\ -0.13 \end{matrix}$	W $\begin{matrix} +0.28 \\ -0.25 \end{matrix}$	Z max.
8	12.01	15.9	11.35	14.27	2.39	9.80
10	14.99	19.1	11.35	17.07	2.39	9.80
12	19.05	21.4	11.35	19.84	2.39	9.80
14	22.23	24.6	11.35	23.01	2.39	9.80
16	25.40	27.8	11.35	26.19	2.39	9.80
18	28.58	30.9	11.35	29.36	2.39	9.80
20	31.75	33.3	12.93	31.75	2.39	9.80
22	34.93	36.5	12.93	34.92	3.18	10.62
24	38.10	39.7	13.77	38.10	3.18	10.62

Assembly instructions p. 60-68.

## Hermetically sealed receptacle PT 02 H (MS 3112 H)

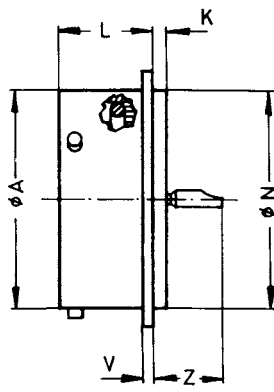

**PT 02 H**  
(MS 3112 H)

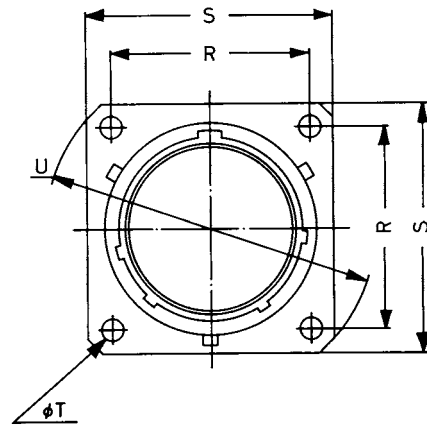

Ordering example      PT 02 H 18-32 P W      see p. 70

### Dimensions in mm

Shell size	Ø A	K	L	Ø N	R	S	T	U	V	Z
	+0.025 -0.13	±0.41	+0.66 -0.38	+0.03 -0.13	±0.15	max.	min.	±0.41	+0.28 -0.25	max.
8	12.01	1.20	12.55	14.27	15.08	21.02	2.9	26.97	1.57	8.74
10	14.99	1.20	12.55	17.07	18.26	24.23	2.9	31.75	1.57	8.74
12	19.05	1.20	12.55	19.84	20.62	26.59	2.9	34.93	1.57	8.74
14	22.23	1.20	12.55	23.01	23.01	28.98	2.9	38.10	1.57	8.74
16	25.40	1.20	12.55	26.19	24.61	31.34	2.9	41.28	1.57	8.74
18	28.58	1.20	12.55	29.36	26.97	33.73	2.9	44.45	1.57	8.74
20	31.75	1.20	14.12	31.75	29.36	36.91	2.9	47.63	1.57	8.74
22	34.93	2.01	14.12	34.93	31.75	40.08	2.9	50.80	1.57	9.58
24	38.10	2.01	14.94	38.10	34.93	43.26	3.6	55.58	1.57	9.58

Assembly instructions p. 60-68.

# Hermetically sealed receptacle for single hole mounting PT 07 H (VG 95328)

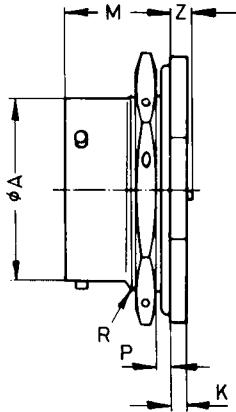

**PT 07 H**  
(VG 95328 F / MS 3114 H)

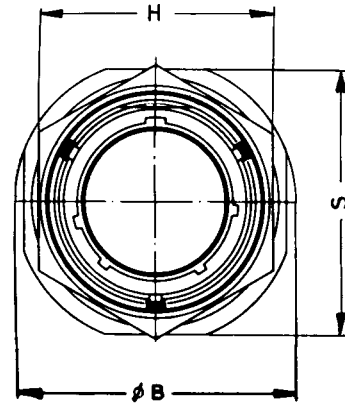

Ordering example      PT 07 H 18-32 P W      see p. 70

## Dimensions in mm

Shell size	Ø A +0.03 -0.13	Ø B max.	H ±0.4	K ±0.5	M ±0.8 0	P (mounting wall)		Thread R Class 2 A (inch)	S max.	Z max.
						min.	max.			
8	12.01	27.5	19.1	3.0	17.5	1.6	3.2	0.5625-24 NEF	24.24	3.28
10	14.99	30.5	22.2	3.0	17.5	1.6	3.2	0.6875-24 NEF	27.28	3.28
12	19.05	35.5	27.0	3.0	17.5	1.6	3.2	0.8750-24 UNEF	32.16	3.28
14	22.23	38.5	30.2	3.0	17.5	1.6	3.2	1.0000-20 UNEF	35.33	3.28
16	25.40	41.5	33.3	3.0	17.5	1.6	3.2	1.1250-20 NEF	38.51	3.28
18	28.58	45.0	36.5	3.0	17.5	1.6	3.2	1.2500-18 NEF	41.68	3.28
20	31.75	49.5	39.7	3.8	22.3	1.6	3.2	1.3750-18 NEF	46.43	0.89
22	34.93	52.5	42.9	3.8	22.3	1.6	3.2	1.5000-18 NEF	49.63	0.89
24	38.10	56.0	46.0	3.8	23.1	1.6	3.2	1.6250-18 NEF	52.78	1.16

Assembly instructions p. 60-68.

## PT-GS Series

PCB connection

This series contains receptacles PT 02 GS and PT 07 GS with **non-removable** contacts. The receptacles are identical to those of service class C (see p. 15), with the exception of contacts designed for soldering onto rigid or flexible PCBs. The contact bore holes necessary for assembly are shown on pages 33 to 37, and show the front view of the pin insert when the receptacle is in the normal position.



**PT 02 GS**  
Box mounting receptacle



**PT 07 GS**  
Receptacle for single hole mounting  
(with O-ring)

## PT-WW Series

Wire-wrap connection

The PT receptacle types PT 02 WW and PT 07 WW are identical to those in PT series operating class C, with the exception of the contacts, which are designed for wire-wrap connections and **non-removable**.

The cross-section of the wire-wrap pin is 0.6 x 0.6 mm and corresponds to the specifications in DIN 41611, Sheet 2.

The contact bore holes with the specified coordinates shown on pages 61 to 65 allow semi- and fully automatic wrapping. They show the front view of the pin insert when the receptacle is in the normal position. (see p. 6)



**PT 02 WW**  
Box mounting receptacle



**PT 07 WW**  
Receptacle for single hole mounting  
(with O-ring)

Assembly instructions p. 60-68.



## Box mounting receptacle PT 02 GS

The dimensions are shown only for pole arrangements with size 20 contacts, such as those on pages 33-37.

Other pole arrangements upon request.

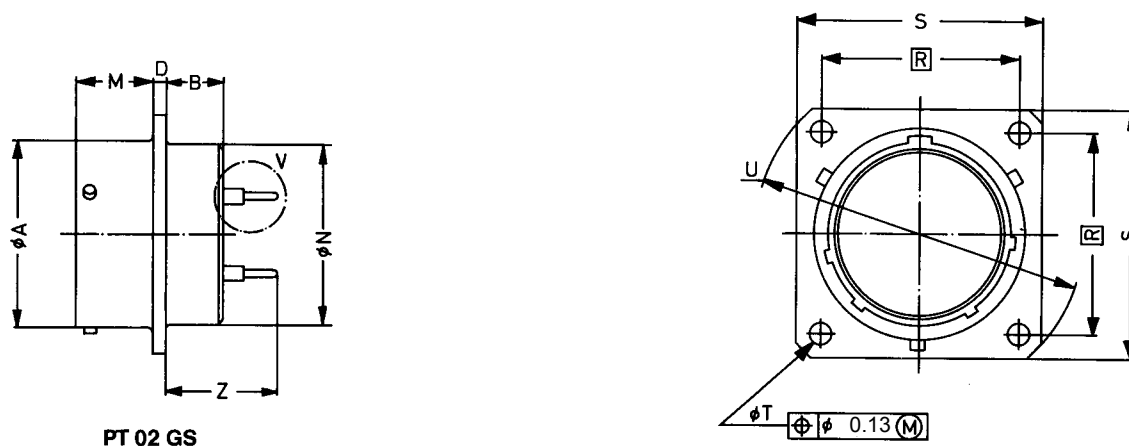

### Detail V

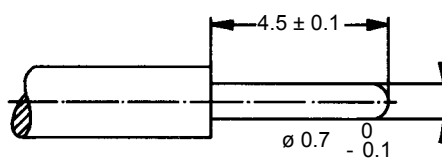

Ordering example      PT 02 GS 18-32 P      see p. 70

### Dimensions in mm

Shell size	∅ A	B	D	M	∅ N	<span style="border: 1px solid black; padding: 0 2px;">R</span>	S	T	U	Z
	+0.03 -0.13	-0.25	±0.25	+0.25 0	max.	Theoret. dimensions	max.	±0.1	±0.41	±0.7
8	12.01	6.35	1.57	10.95	11.40	15.1	21.02	3.05	26.97	15.0
10	14.99	6.35	1.57	10.95	14.55	18.3	24.23	3.05	31.75	15.0
12	19.05	6.35	1.57	10.95	17.75	20.6	26.59	3.05	34.93	15.0
14	22.23	6.35	1.57	10.95	20.90	23.0	28.98	3.05	38.10	15.0
16	25.40	6.35	1.57	10.95	24.10	24.6	31.20	3.05	41.28	15.0
18	28.58	6.35	1.57	10.95	27.25	27.0	33.73	3.05	44.45	15.0
20	31.75	8.74	2.39	14.12	30.45	29.4	36.91	3.05	47.63	17.1
22	34.93	8.74	2.39	14.12	33.60	31.8	40.08	3.05	50.80	17.1
24	38.10	8.74	2.39	14.96	36.80	34.9	43.26	3.73	55.58	16.2

Assembly instructions p. 60-68.

## Receptacle for single hole mounting PT 07 GS

The dimensions are shown only for pole arrangements with size 20 contacts, such as those on pages 33-37.

Other pole arrangements upon request.

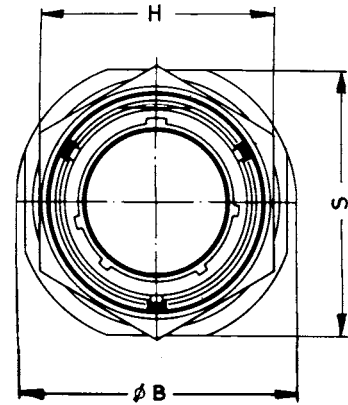
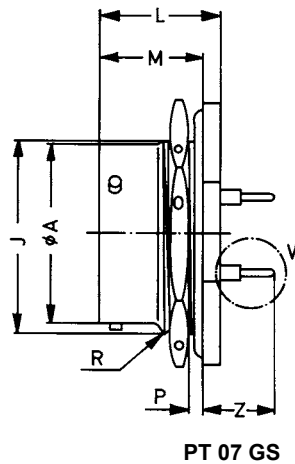

### Detail V

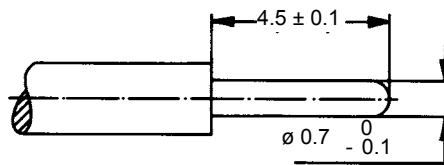

Ordering example      PT 07 GS 18-32 P      see p. 70

### Dimensions in mm

Shell size	Ø A	Ø B	H	J	L	M	P		Thread R Class 2 A (inch)	S	Z
	+0.03 -0.13	max.	±0.4	0 -0.25	±0.13	±0.13	min.	max.		max.	±0.7
8	12.01	27.5	19.1	13.46	20.9	17.68	1.6	3.2	0.5625-24 NEF	24.24	10.0
10	14.99	30.5	22.2	16.64	20.9	17.68	1.6	3.2	0.6875-24 NEF	27.28	10.0
12	19.05	35.5	27.0	20.78	20.9	17.68	1.6	3.2	0.8750-24 UNEF	32.16	10.0
14	22.23	38.5	30.2	23.93	20.9	17.68	1.6	3.2	1.0000-20 UNEF	35.33	10.0
16	25.40	41.5	33.3	27.08	20.9	17.68	1.6	3.2	1.1250-20 NEF	38.51	10.0
18	28.58	45.0	36.5	30.25	20.9	17.68	1.6	3.2	1.2500-18 NEF	41.68	10.0
20	31.75	49.5	39.7	33.43	26.4	22.45	1.6	6.4	1.3750-18 NEF	46.43	11.2
22	34.93	52.5	42.9	36.60	26.4	22.45	1.6	6.4	1.5000-18 NEF	49.63	11.2
24	38.10	56.0	46.1	39.78	27.3	23.39	1.6	6.4	1.6250-18 NEF	52.78	10.5

Assembly instructions p. 60-68.

## Contact bore holes for receptacles

With GS dip solder contacts (p. 30-32)

This and the following pages show the front view of the pin insert  
in the normal position (see p. 6).

**8 - 2**  
2 Contacts  
Size 20

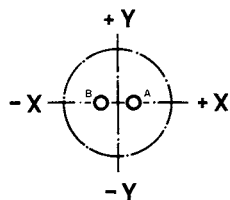

Contact	X	Y
A	+ 1.50	0
B	- 1.50	0

**8 - 3**  
3 Contacts  
Size 20

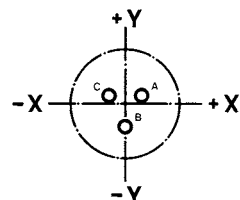

Contact	X	Y
A	+ 1.42	+ 0.46
B	0	- 2.01
C	- 1.42	+ 0.46

**8 - 3A**  
3 Contacts  
Size 20

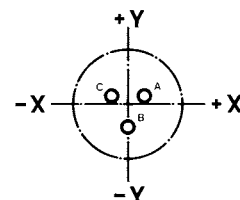

Contact	X	Y
A	+ 1.65	+ 0.95
B	0	- 1.91
C	- 1.65	+ 0.95

**8 - 4**  
4 Contacts  
Size 20

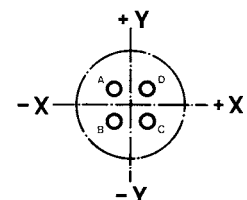

Contact	X	Y
A	- 1.42	+ 1.42
B	- 1.42	- 1.42
C	+ 1.42	- 1.42
D	+ 1.42	+ 1.42

**10 - 6**  
6 Contacts  
Size 20

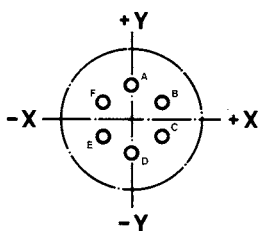

Contact	X	Y
A	0	+ 3.30
B	+ 2.87	+ 1.65
C	+ 2.87	- 1.65
D	0	- 3.30
E	- 2.87	- 1.65
F	- 2.87	+ 1.65

**10 - 98**  
6 Contacts  
Size 20

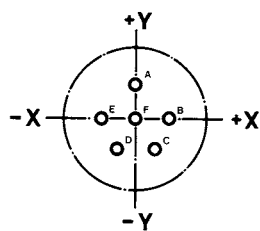

Contact	X	Y
A	0	+ 3.30
B	+ 3.30	0
C	+ 1.65	- 2.87
D	- 1.65	2.87
E	- 3.30	0
F	0	0

**12 - 8**  
8 Contacts  
Size 20

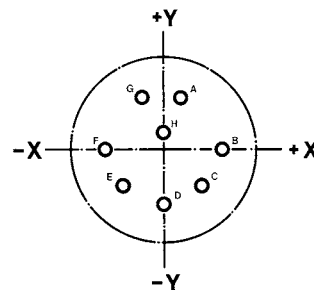

Contact	X	Y
A	+ 1.65	+ 3.99
B	+ 4.32	0
C	+ 3.05	- 3.05
D	0	- 4.32
E	- 3.05	- 3.05
F	- 4.32	0
G	- 1.65	+ 3.99
H	0	+ 1.12

**12 - 10**  
10 Contacts  
Size 20

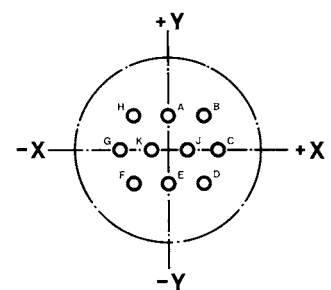

Contact	X	Y
A	0	+ 3.05
B	+ 3.30	+ 3.05
C	+ 4.95	0
D	+ 3.30	- 3.05
E	0	- 3.05
F	- 3.30	- 3.05
G	- 4.95	0
H	- 3.30	+ 3.05
J	+ 1.65	0
K	- 1.65	0

**Contact bore holes for receptacles**  
With GS dip solder contacts (p. 30-32)

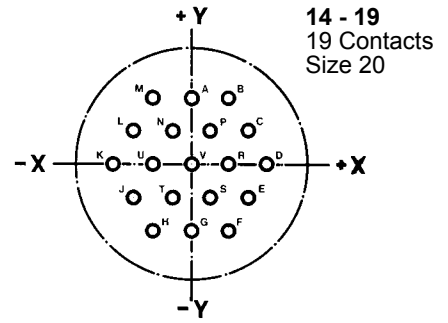
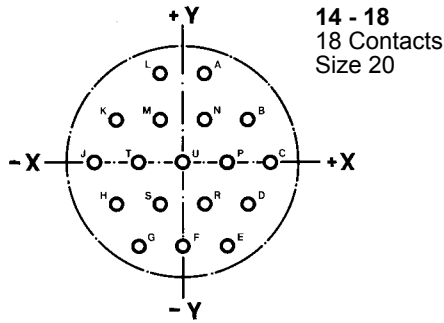

Contact	X	Y	Contact	X	Y
A	+ 1.65	+ 6.40	K	- 4.95	+ 2.87
B	+ 4.95	+ 2.87	L	- 1.65	+ 6.40
C	+ 6.60	0	M	- 1.65	+ 2.87
D	+ 4.95	- 2.87	N	+ 1.65	+ 2.87
E	+ 3.30	- 5.72	P	+ 3.30	0
F	0	- 5.72	R	+ 1.65	- 2.87
G	- 3.30	- 5.72	S	- 1.65	- 2.87
H	- 4.95	- 2.87	T	- 3.30	0
J	- 6.60	0	U	0	0

Contact	X	Y	Contact	X	Y
A	0	+ 5.72	L	- 4.95	+ 2.87
B	+ 3.30	+ 5.72	M	- 3.30	+ 5.72
C	+ 4.95	+ 2.87	N	- 1.65	+ 2.87
D	+ 6.60	0	P	+ 1.65	+ 2.87
E	+ 4.95	- 2.87	R	+ 3.30	0
F	+ 3.30	- 5.72	S	+ 1.65	- 2.87
G	0	- 5.72	T	- 1.65	- 2.87
H	- 3.30	- 5.72	U	- 3.30	0
J	- 4.95	- 2.87	V	0	0
K	- 6.60	0			

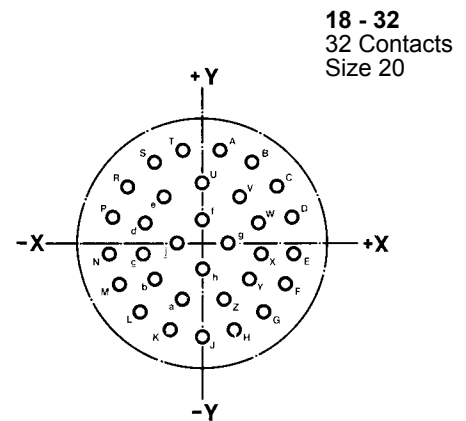
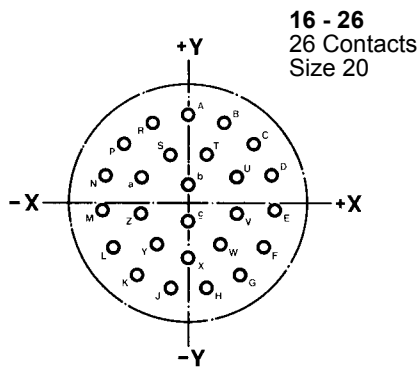

Contact	X	Y	Contact	X	Y
A	0	+ 8.15	P	- 6.07	+ 5.44
B	+ 3.33	+ 7.44	R	- 3.33	+ 7.44
C	+ 6.07	+ 5.44	S	- 1.78	+ 4.50
D	+ 7.75	+ 2.51	T	+ 1.78	+ 4.50
E	+ 8.10	- 0.86	U	+ 4.45	+ 2.39
F	+ 7.06	- 4.09	V	+ 4.52	- 0.91
G	+ 4.80	- 6.60	W	+ 3.02	- 3.84
H	+ 1.70	- 7.98	X	0	+ 5.16
J	- 1.70	- 7.98	Y	- 3.02	- 3.84
K	- 4.80	- 6.60	Z	- 4.52	- 0.91
L	- 7.06	- 4.09	a	- 4.45	+ 2.39
M	- 8.10	- 0.86	b	0	+ 1.65
N	- 7.75	+ 2.51	c	0	- 1.65

Contact	X	Y	Contact	X	Y
A	+ 1.68	+ 8.97	T	- 1.68	+ 8.97
B	+ 4.80	+ 7.75	U	0	+ 5.84
C	+ 7.26	+ 5.51	V	+ 3.15	+ 4.90
D	+ 8.76	+ 2.49	W	+ 5.31	+ 2.41
E	+ 9.07	- 0.84	X	+ 5.79	- 0.84
F	+ 8.15	- 4.06	Y	+ 4.42	- 3.84
G	+ 6.15	- 6.73	Z	+ 1.65	- 5.61
H	+ 3.30	- 8.51	a	- 1.65	- 5.61
J	0	- 9.12	b	- 4.42	- 3.84
K	- 3.30	- 8.51	c	- 5.79	- 0.84
L	- 6.15	- 6.73	d	- 5.31	+ 2.41
M	- 8.15	- 4.06	e	- 3.15	+ 4.90
N	- 9.07	- 0.84	f	0	+ 2.44
P	- 8.76	+ 2.49	g	+ 2.44	0
R	- 7.26	+ 5.51	h	0	- 2.44
S	- 4.80	+ 7.75	j	- 2.44	0

### Contact bore holes for receptacles With GS dip solder contacts (p. 30-32)

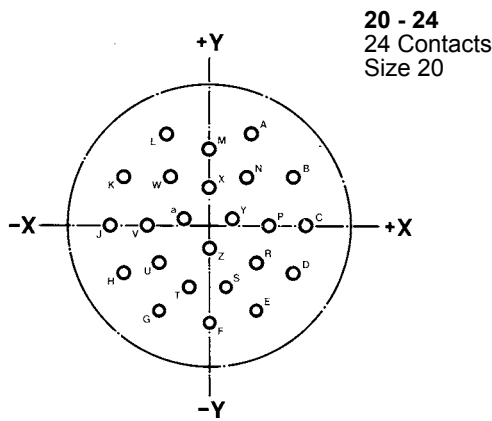

Contact	X	Y	Contact	X	Y
A	+ 4.45	+ 9.53	N	+ 3.81	+ 5.08
B	+ 8.89	+ 5.08	P	+ 6.35	0
C	+10.16	0	R	+ 5.08	- 3.81
D	+ 8.89	- 5.08	S	+ 1.91	- 6.35
E	+ 5.08	- 8.89	T	- 1.91	- 6.35
F	0	-10.16	U	- 5.08	- 3.81
G	- 5.08	- 8.89	V	- 6.35	0
H	- 8.89	- 5.08	W	- 3.81	+ 5.08
J	-10.16	0	X	0	+ 3.81
K	- 8.89	+ 5.08	Y	+ 2.54	+ 0.64
L	- 4.45	+ 9.53	Z	0	- 2.54
M	0	- 7.62	a	- 2.54	+ 0.64

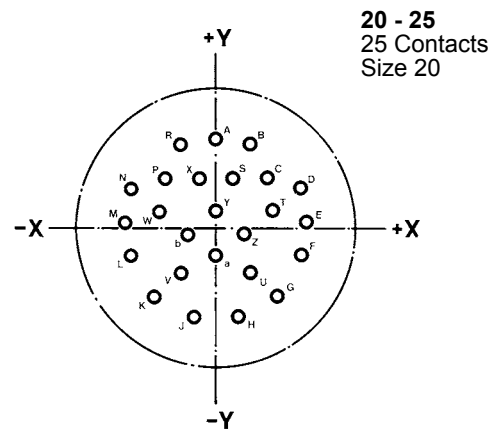

Contact	X	Y	Contact	X	Y
A	0	+ 10.16	P	- 5.72	+ 5.72
B	+ 3.81	+ 9.53	R	- 3.81	+ 9.53
C	+ 5.72	+ 5.72	S	+ 1.91	+ 5.72
D	+ 9.53	+ 4.45	T	+ 6.35	+ 1.91
E	+ 10.16	+ 0.64	U	+ 3.81	- 5.08
F	+ 9.53	- 3.18	V	- 3.81	- 5.08
G	+ 6.99	- 7.62	W	- 6.35	+ 1.91
H	+ 2.54	- 10.16	X	- 1.91	+ 5.72
J	- 2.54	- 10.16	Y	0	+ 1.91
K	- 6.99	- 7.62	Z	+ 3.18	- 0.64
L	- 9.53	- 3.18	a	0	- 3.18
M	- 10.16	+ 0.64	b	- 3.18	- 0.64
N	- 9.53	+ 4.45			

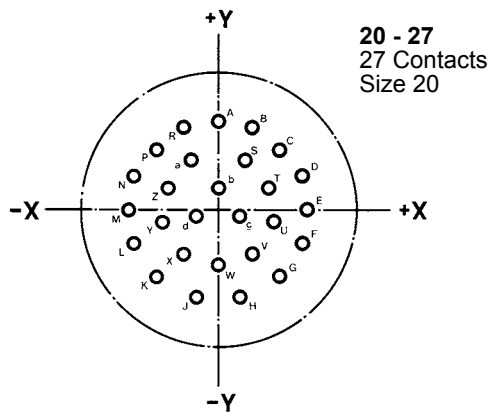

Contact	X	Y	Contact	X	Y
A	0	+ 10.16	R	- 3.81	+ 9.53
B	+ 3.81	+ 9.53	S	+ 3.18	+ 5.72
C	+ 6.99	+ 6.99	T	+ 5.72	+ 2.54
D	+ 9.53	+ 3.81	U	+ 6.35	- 1.27
E	+ 10.16	0	V	+ 3.81	- 5.08
F	+ 9.53	- 3.81	W	0	- 6.35
G	+ 6.99	- 7.62	X	- 3.81	- 5.08
H	+ 2.54	- 10.16	Y	- 6.35	- 1.27
J	- 2.54	- 10.16	Z	- 5.72	+ 2.54
K	- 6.99	- 7.62	a	- 3.18	+ 5.72
L	- 9.53	- 3.81	b	0	+ 2.54
M	- 10.16	0	c	+ 2.54	- 0.64
N	- 9.53	+ 3.81	d	- 2.54	- 0.64
P	- 6.99	+ 6.99			

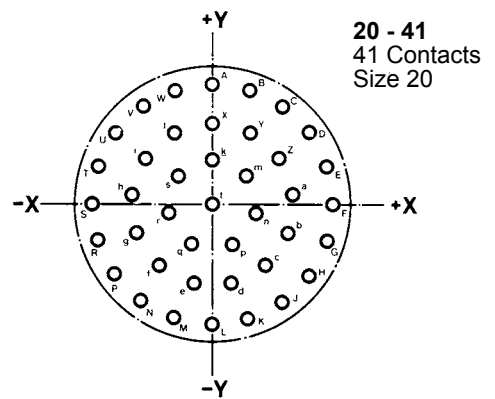

Contact	X	Y	Contact	X	Y
A	0	+ 10.60	Y	+ 3.35	+ 6.38
B	+ 3.28	+ 10.09	Z	+ 5.92	+ 4.09
C	+ 6.23	+ 8.58	a	+ 7.15	+ 0.87
D	+ 8.58	+ 6.23	b	+ 6.73	- 2.55
E	+ 10.09	+ 3.28	c	+ 4.78	- 5.39
F	+ 10.60	0	d	+ 1.73	- 6.99
G	+ 10.09	- 3.28	e	- 1.73	- 6.99
H	+ 8.58	- 6.23	f	- 4.78	- 5.39
J	+ 6.23	- 8.58	g	- 6.73	- 2.55
K	+ 3.28	- 10.09	h	- 7.15	+ 0.87
L	0	- 10.60	i	- 5.92	+ 4.09
M	- 3.28	- 10.09	j	- 3.35	+ 6.38
N	- 6.23	- 8.58	k	0	+ 3.81
P	- 8.58	- 6.23	m	+ 2.98	+ 2.38
R	- 10.09	- 3.28	n	+ 3.71	- 0.85
S	- 10.60	0	p	- 1.66	- 3.43
T	- 10.09	+ 3.28	q	+ 1.66	- 3.43
U	- 8.58	+ 6.23	r	- 3.71	- 0.85
V	- 6.23	+ 8.58	s	- 2.98	+ 2.38
W	- 3.28	+ 10.09	t	0	0
X	0	+ 7.20			

**Contact bore holes for receptacles**  
With GS dip solder contacts (p. 30-32)

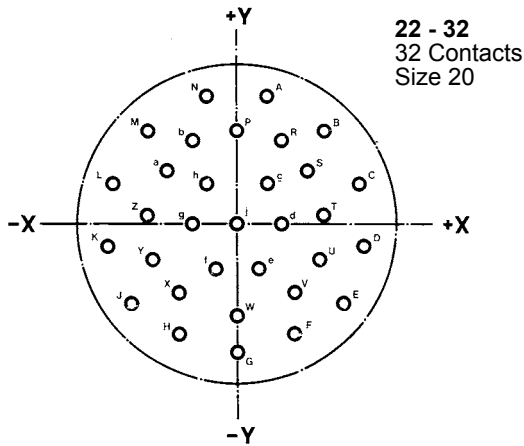

**22 - 32**  
32 Contacts  
Size 20

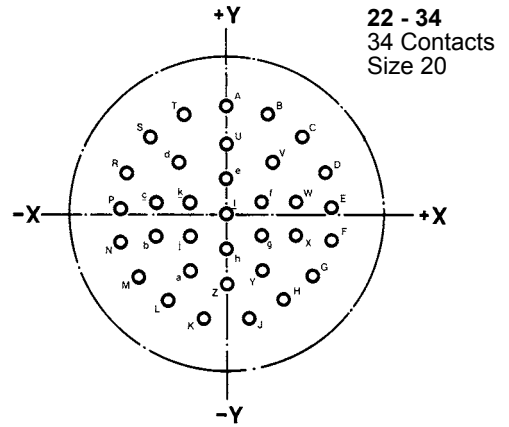

**22 - 34**  
34 Contacts  
Size 20

Contact	X	Y	Contact	X	Y
A	+ 2.54	+ 11.43	T	+ 8.26	+ 0.64
B	+ 8.26	+ 8.26	U	+ 7.62	- 3.18
C	+ 10.80	+ 3.81	V	+ 5.08	- 6.35
D	+ 11.43	- 1.91	W	0	- 7.62
E	+ 9.53	- 6.99	X	- 5.08	- 6.35
F	+ 5.08	- 10.16	Y	- 7.62	- 3.18
G	0	- 11.43	Z	- 8.26	+ 0.64
H	- 5.08	- 10.16	a	- 6.35	+ 4.45
J	- 9.53	- 6.99	b	- 3.81	+ 7.62
K	- 11.43	- 1.91	c	+ 2.54	+ 3.81
L	- 10.80	+ 3.81	d	+ 3.81	0
M	- 8.26	+ 8.26	e	+ 1.91	- 3.81
N	- 2.54	+ 11.43	f	- 1.91	- 3.81
P	0	+ 8.26	g	- 3.81	0
R	+ 3.81	+ 7.62	h	- 2.54	+ 3.81
S	+ 6.35	+ 4.45	j	0	0

Contact	X	Y	Contact	X	Y
A	0	+ 11.43	U	0	+ 7.62
B	+ 4.45	+ 10.80	V	+ 5.08	+ 5.72
C	+ 8.26	+ 8.26	W	+ 7.62	+ 1.27
D	+ 10.80	+ 4.45	X	+ 7.62	- 2.54
E	+ 11.43	+ 0.64	Y	+ 3.81	- 6.35
F	+ 11.43	- 3.18	Z	0	- 7.62
G	+ 9.53	- 6.99	a	- 3.81	- 6.35
H	+ 6.35	- 9.53	b	- 7.62	- 2.54
J	+ 2.54	- 11.43	c	- 7.62	+ 1.27
K	- 2.54	- 11.43	d	- 5.08	+ 5.72
L	- 6.35	- 9.53	e	0	+ 3.81
M	- 9.53	- 6.99	f	+ 3.81	+ 1.27
N	- 11.43	- 3.18	g	+ 3.81	- 2.54
P	- 11.43	+ 0.64	h	0	- 3.81
R	- 10.80	+ 4.45	j	- 3.81	- 2.54
S	- 8.26	+ 8.26	k	- 3.81	+ 1.27
T	- 4.45	+ 10.80	l	0	0

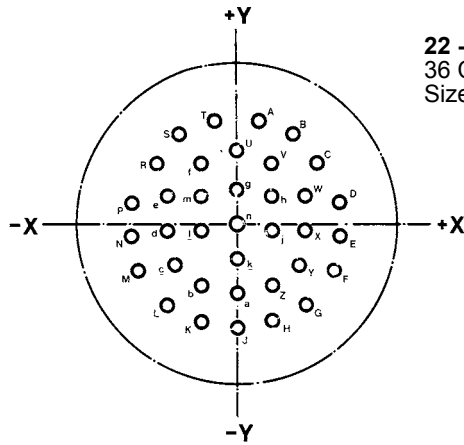

**22 - 36**  
36 Contacts  
Size 20

Contact	X	Y	Contact	X	Y
A	+ 2.54	+ 11.43	V	+ 3.81	+ 6.99
B	+ 6.35	+ 10.16	W	+ 7.62	+ 3.18
C	+ 8.89	+ 6.99	X	+ 7.62	- 0.64
D	+ 11.43	+ 2.54	Y	+ 6.99	- 4.45
E	+ 11.43	- 1.27	Z	+ 3.81	- 6.99
F	+ 10.80	- 5.08	a	0	- 7.62
G	+ 7.62	- 8.89	b	- 3.81	- 6.99
H	+ 3.81	- 10.80	c	- 6.99	- 4.45
J	0	- 11.43	d	- 7.62	- 0.64
K	- 3.81	- 10.80	e	- 7.62	+ 3.18
L	- 7.62	- 8.89	f	- 3.81	+ 6.99
M	- 10.80	- 5.08	g	0	+ 3.81
N	- 11.43	- 1.27	h	+ 3.81	+ 3.18
P	- 11.43	+ 2.54	j	+ 3.81	- 0.64
R	- 8.89	+ 6.99	k	0	- 3.81
S	- 6.35	+ 10.16	l	- 3.81	- 0.64
T	- 2.54	+ 11.43	m	- 3.81	+ 3.18
U	0	+ 8.26	n	0	0

## Contact bore holes for receptacles

With GS dip solder contacts (p. 30-32)

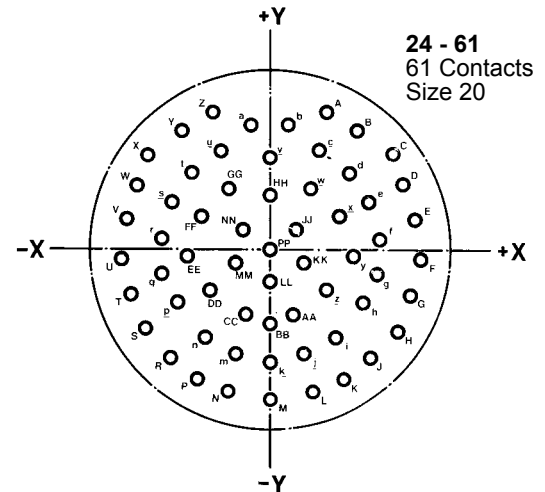
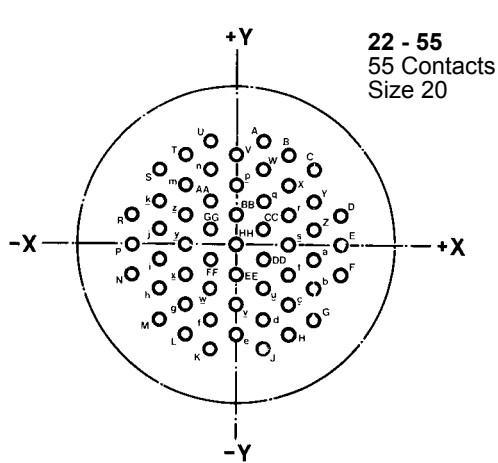

Contact	X	Y	Contact	X	Y
A	+ 2.84	+ 11.56	f	- 2.84	- 8.26
B	+ 5.72	+ 9.91	g	- 5.72	- 6.60
C	+ 8.53	+ 8.26	h	- 8.53	- 4.95
D	+ 11.43	+ 3.30	i	- 8.53	- 1.65
E	+ 11.43	0	j	- 8.53	+ 1.65
F	+ 11.43	- 3.30	k	- 8.53	+ 4.95
G	+ 8.53	- 8.26	m	- 5.72	- 6.60
H	+ 5.72	- 9.91	n	- 2.84	+ 8.26
J	+ 2.84	- 11.56	p	0	+ 6.60
K	- 2.84	- 11.56	q	+ 2.84	+ 4.95
L	- 5.72	- 9.91	r	+ 5.72	+ 3.30
M	- 8.53	- 8.26	s	+ 5.72	0
N	- 11.43	- 3.30	t	+ 5.72	- 3.30
P	- 11.43	0	u	+ 2.84	- 4.95
R	- 11.43	+ 3.30	v	0	- 6.60
S	- 8.53	+ 8.26	w	- 2.84	- 4.95
T	- 5.72	+ 9.91	x	- 5.72	- 3.30
U	- 2.84	+ 11.56	y	- 5.72	0
V	0	+ 9.91	z	- 5.72	+ 3.30
W	+ 2.84	+ 8.26	AA	- 2.84	+ 4.95
X	+ 5.72	+ 6.60	BB	0	+ 3.30
Y	+ 8.53	+ 4.95	CC	+ 2.84	+ 1.65
Z	+ 8.53	+ 1.65	DD	+ 2.84	- 1.65
a	+ 8.53	- 1.65	EE	0	- 3.30
b	+ 8.53	- 4.95	FF	- 2.84	- 1.65
c	+ 8.53	- 6.60	GG	- 2.84	+ 1.65
d	+ 2.84	- 8.26	HH	0	0
e	0	- 9.91			

Contact	X	Y	Contact	X	Y
A	+ 4.98	+ 12.70	i	+ 6.38	- 7.98
B	+ 7.98	+ 11.05	j	+ 3.38	- 9.63
C	+ 10.49	+ 8.71	k	0	- 10.21
D	+ 12.32	+ 5.84	m	- 3.38	- 9.63
E	+ 13.39	+ 2.57	n	- 6.38	- 7.98
F	+ 13.61	- 0.76	p	- 8.66	- 5.41
G	+ 12.98	- 4.17	q	- 9.96	- 2.24
H	+ 11.53	- 7.29	r	- 10.13	+ 1.17
J	+ 9.35	- 9.93	s	- 9.19	+ 4.45
K	+ 6.58	- 11.94	t	- 7.24	+ 7.19
L	+ 3.40	- 13.18	u	- 4.39	+ 9.22
M	0	- 13.64	v	0	+ 8.59
N	- 3.40	- 13.18	w	+ 3.73	+ 5.66
P	- 6.58	- 11.94	x	+ 6.02	+ 3.10
R	- 9.35	- 9.93	y	+ 6.78	- 0.25
S	- 11.53	- 7.29	z	+ 5.79	- 3.53
T	- 12.98	- 4.17	AA	+ 3.33	- 5.92
U	- 13.61	- 0.76	BB	0	- 6.78
V	- 13.39	+ 2.57	CC	- 3.33	- 5.92
W	- 12.32	+ 5.84	DD	- 5.79	- 3.53
X	- 10.49	+ 8.71	EE	- 6.78	- 0.25
Y	- 7.98	+ 11.05	FF	- 6.02	+ 3.10
Z	- 4.98	+ 12.70	GG	- 3.73	+ 5.66
a	- 1.73	+ 11.53	HH	0	+ 5.08
b	+ 1.73	+ 11.53	JJ	+ 2.67	+ 2.39
c	+ 4.93	+ 9.22	KK	+ 3.43	- 1.04
d	+ 7.24	+ 7.19	LL	0	- 3.35
e	+ 9.19	+ 4.45	MM	- 3.43	- 1.04
f	+ 10.13	+ 1.17	NN	- 2.67	+ 2.39
g	+ 9.96	- 2.24	PP	0	0
h	+ 8.66	- 5.41			

**Box mounting receptacle PT 02 WW**

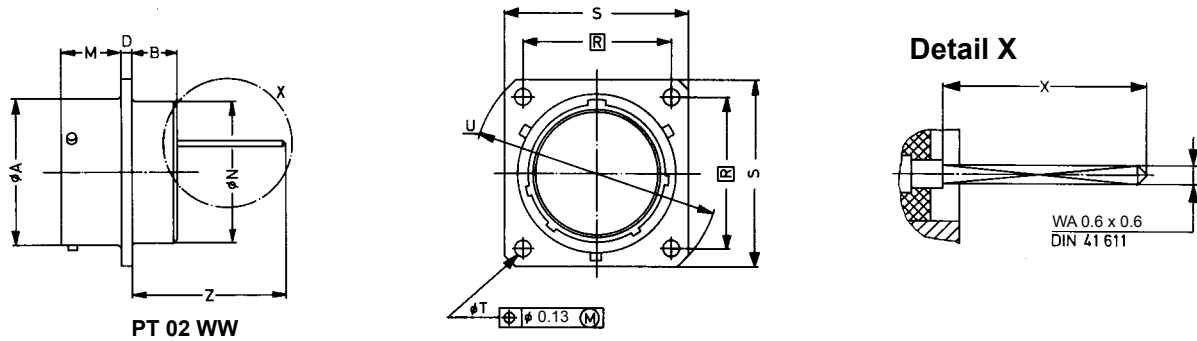

Ordering example **PT 02 WW 14-19 P W** see p. 70

Dimensions in mm

Shell size	Ø A	B	D	M	Ø N	R	S	T	U	X	Z
	+0.03 -0.13	-0.25	±0.25	+0.25 0	max.	Theor. dimension	max.	±0.13	±0.41	±0.5	max.
8	12.01	6.35	1.57	10.95	11.40	15.09	21.02	3.05	26.97	13	20.2
10	14.99	6.35	1.57	10.95	14.55	18.26	24.23	3.05	31.75	13	20.2
12	19.05	6.35	1.57	10.95	17.75	20.62	26.59	3.05	34.93	13	20.2
14	22.23	6.35	1.57	10.95	20.90	23.01	28.98	3.05	38.10	13	20.2
16	25.40	6.35	1.57	10.95	24.10	24.61	31.34	3.05	41.28	13	20.2
18	28.58	6.35	1.57	10.95	27.25	26.97	33.83	3.05	44.45	13	20.2
20	31.75	8.74	2.39	14.12	30.45	29.36	36.91	3.05	47.63	13	23.3
22	34.93	8.74	2.39	14.12	33.60	31.75	40.08	3.05	50.80	13	23.3
24	38.10	8.74	2.39	14.96	36.80	34.93	43.26	3.73	55.58	13	22.5

**Receptacle for single hole mounting PT 07 WW**

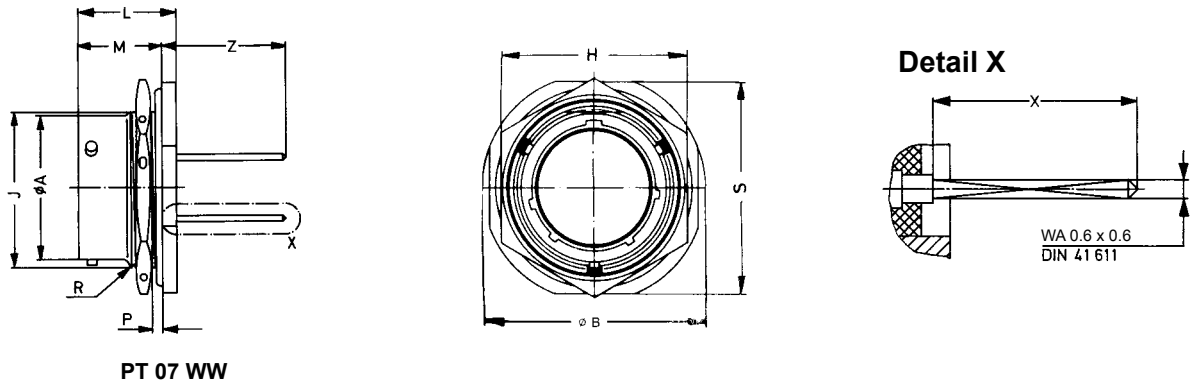

Ordering example **PT 07 WW 14-19 P W** see p. 70

Dimensions in mm

Shell size	Ø A	Ø B	H	J	L	M	P		Thread R Class 2 A (inch)	S max.	X ±0.5	Z max.
	+0.03 -0.13	max.	±0.4	0 -0.3	±0.13	±0.13	min.	max.				
8	12.01	27.5	19.1	13.46	20.9	17.68	1.6	3.2	0.5625-24 NEF	24.24	13	15.1
10	14.99	30.5	22.2	16.64	20.9	17.68	1.6	3.2	0.6875-24 NEF	27.38	13	15.1
12	19.05	35.5	27.0	20.78	20.9	17.68	1.6	3.2	0.8750-20 UNEF	32.16	13	15.1
14	22.23	38.5	30.2	23.93	20.9	17.68	1.6	3.2	1.0000-20 UNEF	35.33	13	15.1
16	25.40	41.5	33.3	27.08	20.9	17.68	1.6	3.2	1.1250-18 NEF	38.51	13	15.1
18	28.58	45.0	36.5	30.25	20.9	17.68	1.6	3.2	1.2500-18 NEF	41.68	13	15.1
20	31.75	49.5	39.7	33.43	26.4	22.45	1.6	6.4	1.3750-18 NEF	46.43	13	17.3
22	34.93	52.5	42.9	36.60	26.4	22.45	1.6	6.4	1.5000-18 NEF	49.63	13	17.3
24	38.10	56.0	46.0	39.78	27.3	23.39	1.6	6.4	1.6250-18 NEF	52.78	13	16.6

WW version only with contact size 20.  
Other contact sizes upon request.

Assembly instructions p. 60-68.



The PT-SE series includes the following types of plugs and receptacles with removable crimp contacts. The connectors of this series are attachable to and interchangeable with all the connectors of the MIL-C-26482, VG 95328, LN 29500, LN 29504, MIL-C-83723, NAS 1599, NFL 54125, DEF 5325-3/5326-3 and IEC publication 130-7 standards.

The connectors in this series, which can be delivered with different backshells depending on service class (see page 40), are specified in accordance with MIL-C-26482, Series 1 and VG 95328 (see p. 13).

### Shell design features

- Aluminum alloy.
- Surface treatment: cadmium and green chromate coating; conductive = standard. Other surfaces: see p. 70
- Three pin bayonet coupling.
- 5 guide grooves and lugs for perfect coupling.
- Up to 5 angular positions ensure polarization of the contact insert and main guide groove.
- 7 shell designs (see p. 41 to 51).
- 9 shell sizes (size 8 to 24).
- HF-sealed 360° via grounding ring in plug PTG 06 SE.
- Protection class as per IEC 529: IP 67 depending on backshell.

### Contact insert

- Neoprene insert.
- Numerous contact arrangements with 3 to 61 contacts.
- Contact designation on mating and termination face.
- Sealing elements on mating and termination face.

### Crimp contacts

- Pin and socket contacts made of high-quality copper alloy.
- Hard gold plated contact surface.
- Contact sizes AWG 16 and 20 (see page 5).
- Pin and socket contacts are removable.
- Ordering information page 70



**PT 00 SE**  
Wall mounting  
receptacle



**PT 01 SE**  
Cable connecting  
plug



**PT 02 SE**  
Box mounting  
receptacle



**PT 07 SE**  
Receptacle  
for single hole  
mounting  
(with O-ring)



**PT 06 SE**  
Straight plug



**PT 06 SE ... SQ**  
Straight plug  
(HF-sealed)



**PT 08 SE**  
Angle plug

## Service classes and backshells

In order to meet different environmental requirements, PT-SE connectors are available in both service classes named below, with several different backshells.

### Service classes

Service class	Characteristics
»SE«	Moisture-proof version. Single wire seals.
»SP«	Similar to service class »SE«, yet for sealing wire bundles.

### Backshells

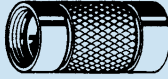
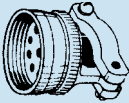
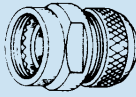
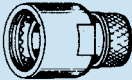
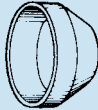
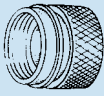
Backshells	Characteristics	Backshells	Characteristics
 SE	Backshell for single wire sealing.	 SE ... PG	Backshells for sealing jacketed and shielded/unshielded wires.
 SE ... SR	Backshell with cable clamp for single wire sealing.	 SE ... SQ	Backshells for attaching shielding braids and heat shrink parts (see p. 60).
 SE ... F	Backshell (twist-proof) for attaching heat shrink parts (see p. 60).	 SP	Nylon potting boot for sealing wire bundles.
 SE ... J	Backshell for attaching heat shrink parts (see p. 60).		

### Available connectors

Connector	Service class	
	»SE«	»SP«
Wall mounting receptacle	PT 00 SE	PT 00 SP
Cable connecting plug	PT 01 SE	PT 01 SP
Box mounting receptacle*	PT 02 SE	- - -
Straight plug	PT 06 SE	PT 06 SP
Straight plug (HF-sealed)	PTG 06 SE	- - -
Receptacle for single hole mounting	PT 07 SE	PT 07 SP
Angle plug	PT 08 SE	PT 08 SP

\*) The receptacle PT 02 SE has no single wire sealing and no backshell.

Ordering information page 70

## Wall mounting receptacle PT 00 SE (VG 95328)

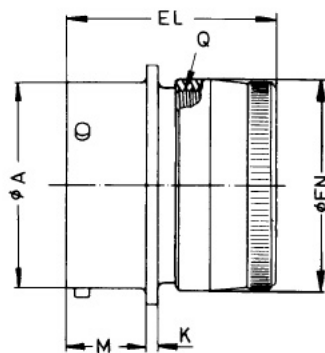

**PT 00 SE**  
(VG 95328 A / MS 3120 E)

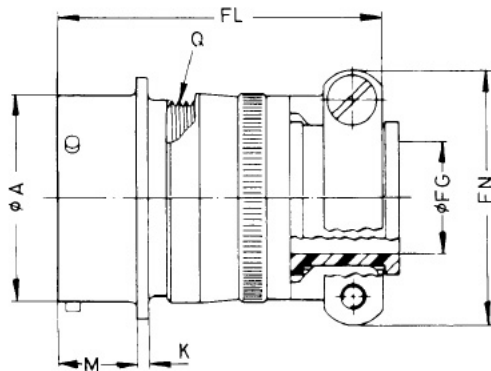
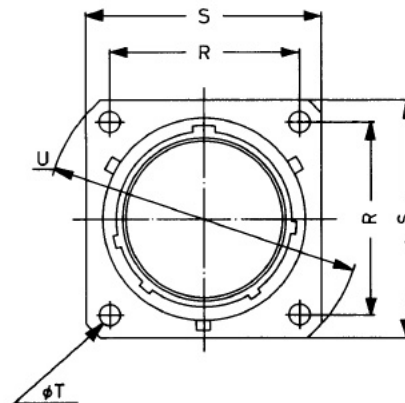

**PT 00 SE...SR**  
(VG 95328 B / MS 3120 F)

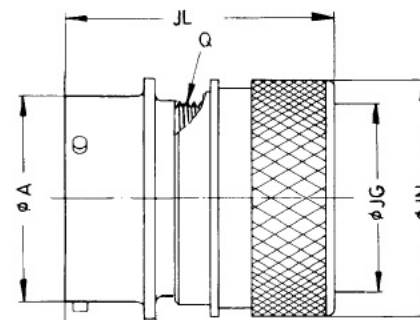

**PT 00 SE...J**

Ordering example      PT 00 SE 14-19 PW SR      see p. 70

Shell size	φA +0.025 -0.13	EL max.	φ EN max.	φ FG ± 0.25	FL max.	FN max.	Ø JG ± 0.1	JL max.	φ JN max.	K max.	M +0.8	Thread Q Class 2 A (inch)	R ±0.15	S max.	φ T min.	U ±0.41
8	12.01	33.73	14.22	3.18	48.82	21.02	7.9	36.91	15.6	2.0	10.94	0.4375-28 UNEF	15.08	21.03	2.9	26.97
10	14.99	33.73	17.40	4.78	48.82	22.63	10.9	37.41	18.4	2.0	10.94	0.5625-24 NEF	18.26	24.23	2.9	31.75
12	19.05	33.73	20.65	7.92	48.82	25.81	13.8	38.21	23.7	2.0	10.94	0.6875-24 NEF	20.62	26.59	2.9	34.93
14	22.23	33.73	23.62	9.53	48.82	28.98	16.9	38.41	24.5	2.0	10.94	0.8125-20 UNEF	23.01	28.98	2.9	38.10
16	25.40	33.73	26.85	12.70	50.80	30.56	20.1	37.91	29.8	2.0	10.94	0.9375-20 UNEF	24.61	31.34	2.9	41.28
18	28.58	33.73	29.85	15.88	50.80	37.31	22.7	38.61	32.0	2.0	10.94	1.0625-18 NEF	26.97	33.73	2.9	44.45
20	31.75	34.52	33.05	15.88	55.17	37.31	25.9	44.78	36.1	2.8	14.12	1.1875-18 NEF	29.36	36.91	2.9	47.63
22	34.93	34.52	36.27	19.05	55.17	42.06	29.0	44.28	38.5	2.8	14.12	1.3125-18 NEF	31.75	40.08	2.9	50.80
24	38.10	36.12	38.94	20.32	56.74	44.45	32.2	44.58	41.5	2.8	14.96	1.4375-18 NEF	34.93	43.26	3.6	55.58

Assembly instructions p. 60-68.

## Wall mounting receptacle PT 00 SE (M 3120)

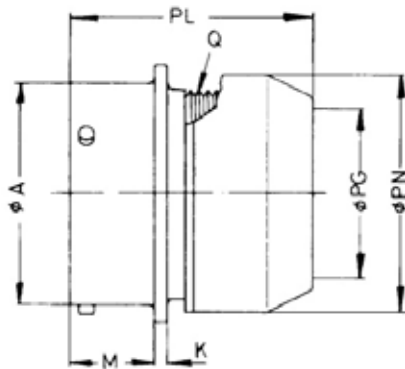

**PT 00 SP**  
(MS 3120 P)

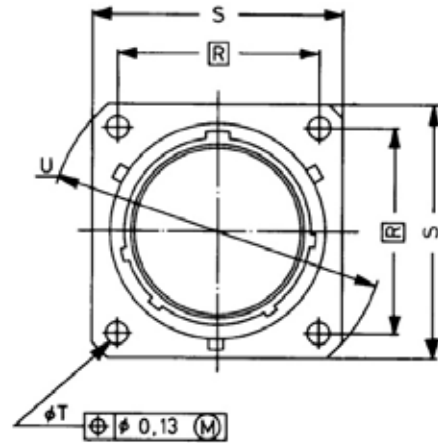

Ordering example      PT 00 SE 14-19 P W SQ      see p. 70

Shell size	Ø A +0.025 - 0.13	K ± 0.41	M + 0.25 0	ø PG min.	PL max.	ø PN max.	Thread Q Class 2 A (inch)	$\overline{R}$ Theor. dimensions	S max.	ø T ± 0.13	U ± 0.41
8	12.01	1.57	10.95	8.05	42.06	15.44	0.4375-28 UNEF	15.09	21.02	3.05	26.97
10	14.99	1.57	10.95	11.02	42.06	18.64	0.5625-24 NEF	18.26	24.23	3.05	31.75
12	19.05	1.57	10.95	13.92	42.06	21.79	0.6875-24 NEF	20.62	26.59	3.05	34.93
14	22.23	1.57	10.95	17.09	42.06	24.99	0.8125-20 UNEF	23.01	28.98	3.05	38.10
16	25.40	1.57	10.95	20.27	42.06	28.19	0.9375-20 UNEF	24.61	31.34	3.05	41.28
18	28.58	1.57	10.95	22.83	42.06	31.34	1.0625-18 NEF	26.97	33.73	3.05	44.45
20	31.75	2.39	14.12	26.01	44.45	34.54	1.1875-18 NEF	29.36	36.91	3.05	47.63
22	34.93	2.39	14.12	29.18	44.45	37.69	1.3125-18 NEF	31.75	40.08	3.05	50.80
24	38.10	2.39	14.96	32.36	45.26	40.89	1.4375-18 NEF	34.93	43.26	3.73	55.58

Assembly instructions p. 60-68.

## Cable connecting plug PT 01 SE (MS 3121)

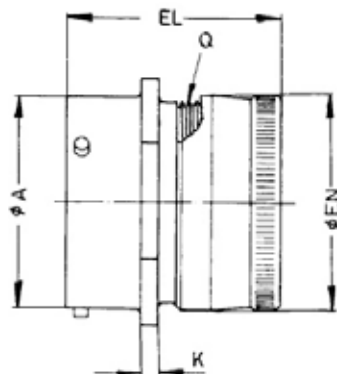

**PT 01 SE**  
(MS 3121 E)

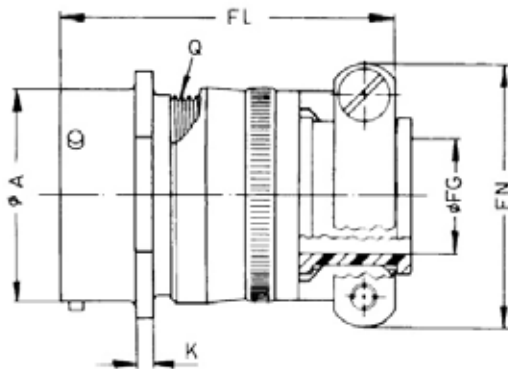
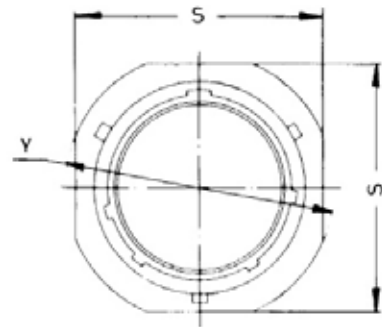

**PT 01 SE...SR** (MS 3121 F)

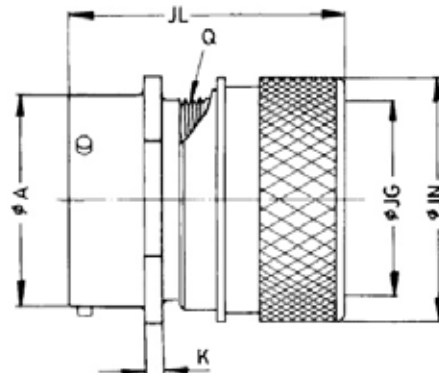

**PT 01 SE...J**

Ordering example PT 01 SE 14-19 P W SR see p. 70

Shell size	Ø A	EL	Ø EN	Ø FG	FL	FN	Ø JG	JL	Ø JN	K	Thread Q	S	Y
	+0.03 - 0.13	max.	max.	± 0.25	max.	max.	+ 0.1	max.	max.	± 0.41	Class 2 A (inch)	max.	± 0.51
8	12.01	33.73	14.22	3.18	48.82	21.02	7.9	36.91	15.6	2.39	0.4375-28 UNEF	21.02	23.83
10	14.99	33.73	17.40	4.78	48.82	22.63	10.9	37.41	18.4	2.39	0.5625-24 NEF	24.26	26.97
12	19.05	33.73	20.65	7.92	48.82	25.81	13.8	38.21	23.7	2.39	0.6875-24 NEF	26.62	29.30
14	22.23	33.73	23.62	9.53	48.82	28.98	16.9	38.41	24.5	2.39	0.8125-20 UNEF	29.01	31.75
16	25.40	33.73	26.85	12.70	50.80	30.56	20.1	37.91	29.8	2.39	0.9375-20 UNEF	31.39	34.14
18	28.58	33.73	29.85	15.88	50.80	37.31	22.7	38.61	32.0	2.39	1.0624-18 NEF	33.76	36.53
20	31.75	34.52	33.05	15.88	55.17	37.31	25.9	44.78	36.1	2.92	1.1875-18 NEF	36.96	39.67
22	34.93	34.52	36.27	19.05	55.17	42.06	29.0	44.28	38.5	2.92	1.3125-18 NEF	40.11	42.88
24	38.10	36.12	38.94	20.32	56.74	44.45	32.2	44.58	41.5	2.92	1.4375-18 NEF	43.28	46.02

Assembly instructions p. 60-68.

## Cable connecting plug PT 01 SE (MS 3121)

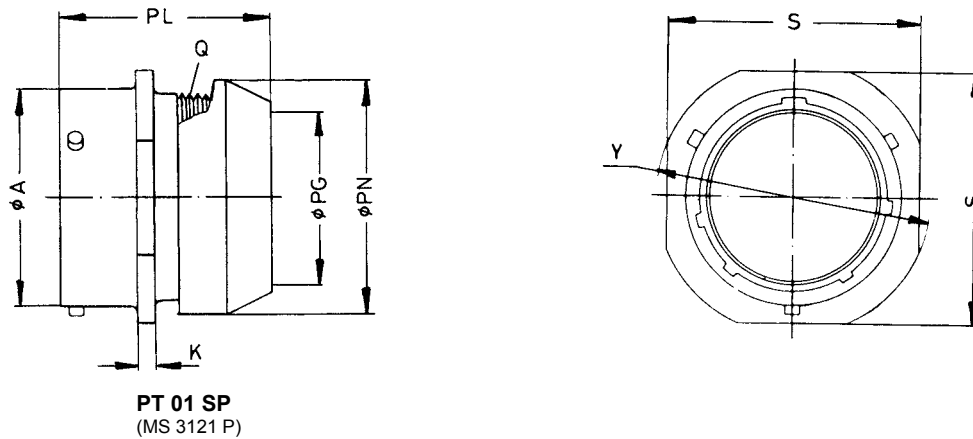

Ordering example    PT 01 SE 14-19 P W SQ    see p. 70

Dimensions in mm

Shell size	Ø A + 0.025 - 0.13	K ± 0.41	Ø PG min.	PL max.	Ø PN max.	Thread Q Class 2 A (inch)	S max.	Y ± 0.51
8	12.01	2.39	8.05	42.06	15.44	0.4375-28 UNEF	21.02	23.83
10	14.99	2.39	11.02	42.06	18.64	0.5625-24 NEF	24.26	26.97
12	19.05	2.39	13.92	42.06	21.79	0.6875-24 NEF	26.62	29.30
14	22.23	2.39	17.09	42.06	24.99	0.8125-20 UNEF	29.01	31.75
16	25.40	2.39	20.27	42.06	28.19	0.9375-20 UNEF	31.39	34.14
18	28.58	2.39	22.83	42.06	31.34	1.0625-18 NEF	33.76	36.53
20	31.75	2.92	26.01	44.45	34.54	1.1875-18 NEF	36.96	39.67
22	34.93	2.92	29.18	44.45	37.69	1.3125-18 NEF	40.11	42.88
24	38.10	2.92	32.36	45.26	40.89	1.4375-18 NEF	43.28	46.02

Assembly instructions p. 60-68.

## Box mounting receptacle PT 02 SE (VG 95328)

This receptacle cannot be equipped with a backshell.

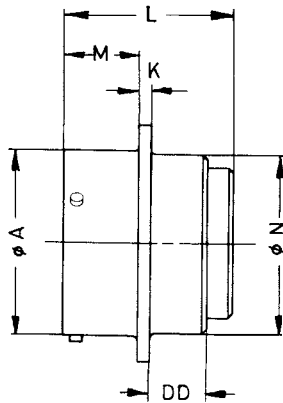

**PT 02 SE**  
(VG 95328 C / MS 3122 E)

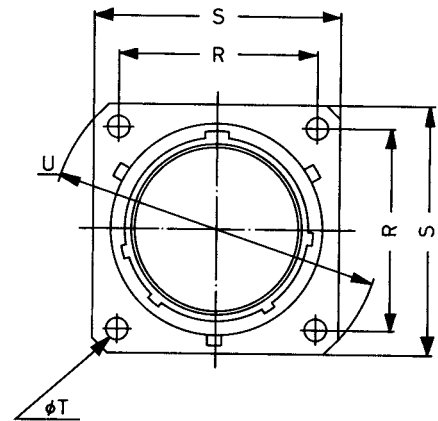

Ordering example

PT 02 SE 14-19 P W

see p. 70

Dimensions in mm

Shell size	$\varnothing A$ + 0.025 -0.13	DD max.	K $\pm 0.41$	L max.	M 0.8 0	$\varnothing N$ max.	R $\pm 0.15$	S max.	$\varnothing T$ min.	U $\pm 0.41$
8	12.01	6.35	1.57	33.5	10.94	11.40	15.08	21.02	2.9	26.97
10	14.99	6.35	1.57	33.5	10.94	14.55	18.26	24.23	2.9	31.75
12	19.05	6.35	1.57	33.5	10.94	17.75	20.62	26.59	2.9	34.93
14	22.23	6.35	1.57	33.5	10.94	20.90	23.01	28.98	2.9	38.10
16	25.40	6.35	1.57	33.5	10.94	24.10	24.61	31.34	2.9	41.28
18	28.58	6.35	1.57	33.5	10.94	27.25	26.97	33.73	2.9	44.45
20	31.75	8.74	2.39	34.7	14.12	30.45	29.36	36.91	2.9	47.63
22	34.93	8.74	2.39	36.0	14.12	33.60	31.75	40.08	2.9	50.80
24	38.10	9.53	2.39	36.0	14.96	36.80	34.93	43.26	3.6	55.58

Assembly instructions p. 60-68.

## Receptacle for single hole mounting PT 07 SE (VG 95328)

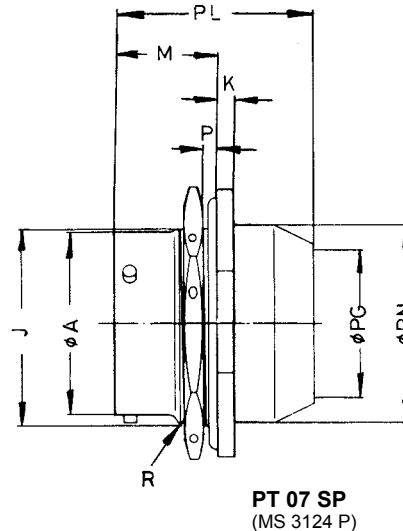
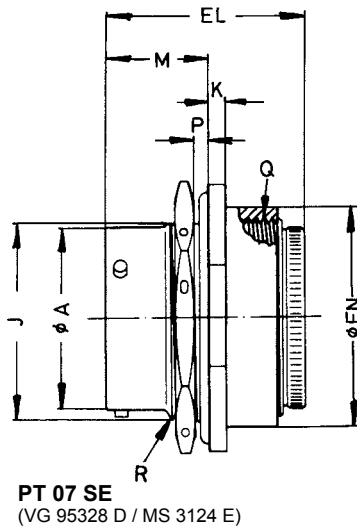
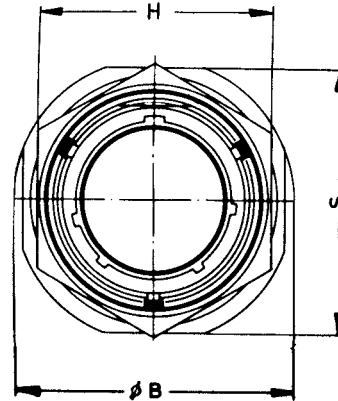
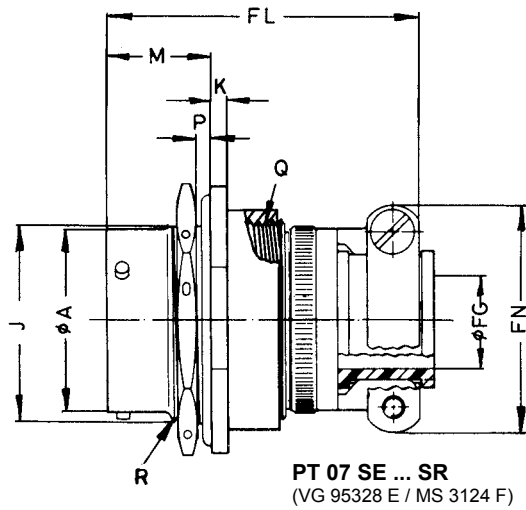

Ordering example

PT 07 SE 14-19 P W SR

see p. 70

Dimensions in mm

Shell size	Ø A	Ø B	EL	ø EN	ø FG	FL	FN	H	J	K	M	P		ø PG	PL	ø PN	Thread Q	Thread R	S
	+0.025 -0.13	max.	max.	max.	±0.25	max.	max.	±0.4	0 -0.25	±0.5	±0.13	(Mounting wall) min. max.	min.	max.	max.	Class 2 B (inch)	Class 2 A (inch)	max.	
8	12.01	27.3	39.29	19.0	3.18	48.82	21.02	19.1	13.46	3.0	17.68	1.6	3.2	8.05	42.06	15.44	0.625-24 NEF	0.5625-24 NEF	24.24
10	14.99	30.5	39.29	22.2	4.78	48.82	22.63	22.2	16.64	3.0	17.68	1.6	3.2	11.02	42.06	18.64	0.750-20 UNEF	0.6875-24 NEF	27.38
12	19.05	35.5	39.29	25.4	7.92	48.82	25.81	27.0	20.78	3.0	17.68	1.6	3.2	13.92	42.06	21.79	0.875-20 UNEF	0.8750-20 UNEF	32.16
14	22.23	38.5	39.29	28.5	9.53	48.82	28.98	30.2	23.93	3.0	17.68	1.6	3.2	17.09	42.06	24.99	1.000-20 UNEF	1.0000-20 UNEF	35.33
16	25.40	41.6	39.29	31.7	12.70	50.80	30.56	33.3	27.08	3.0	17.68	1.6	3.2	20.27	42.06	28.19	1.125-18 NEF	1.1250-18 NEF	38.51
18	28.58	44.8	39.29	34.9	15.88	50.80	37.31	36.5	30.25	3.0	17.68	1.6	3.2	22.83	42.06	31.34	1.250-18 NEF	1.2500-18 NEF	41.68
20	31.75	49.6	43.40	38.8	15.88	55.17	37.31	39.7	33.43	3.8	22.45	1.6	3.2	26.01	48.82	34.54	1.375-18 NEF	1.3750-18 NEF	46.43
22	34.93	52.7	43.40	42.0	19.05	55.17	42.06	42.9	36.60	3.8	22.45	1.6	3.2	29.18	48.82	37.69	1.500-18 NEF	1.5000-18 NEF	49.63
24	38.10	55.9	43.40	45.2	20.32	56.74	44.45	46.0	39.78	3.8	23.39	1.6	3.2	32.36	49.56	40.89	1.625-18 NEF	1.6250-18 NEF	52.78

Assembly instructions p. 60-68.



## Straight plug PT 06 SE (VG 95328)

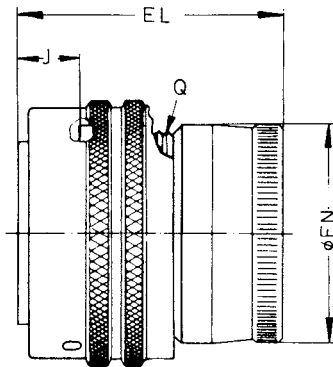

**PT 06 SE**  
(MS 3126 E)

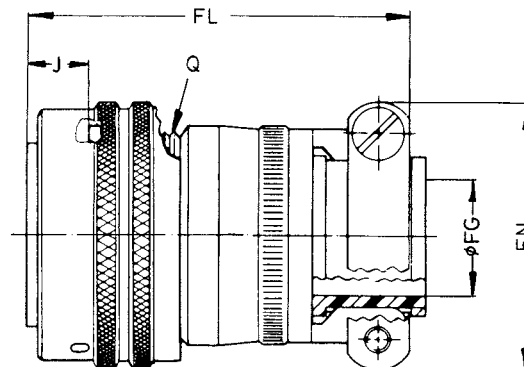

**PT 06 SE ... SR**  
(VG 95328 K / MS 3126 F)

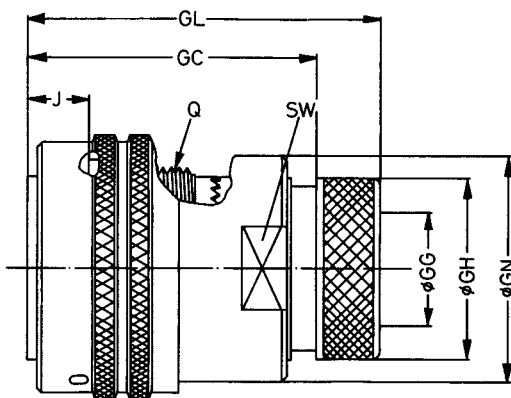
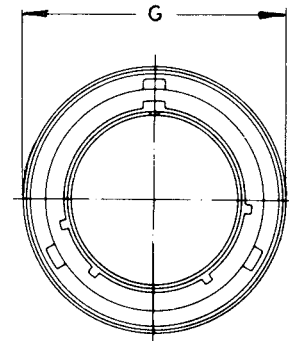

**PT 06 SE ... F**

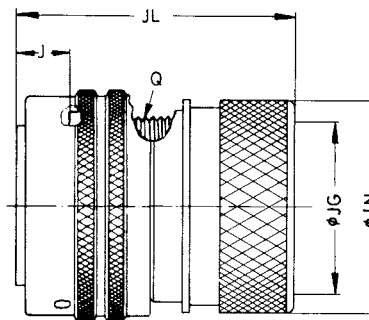

**PT 06 SE ... J**  
(VG 95328 J)

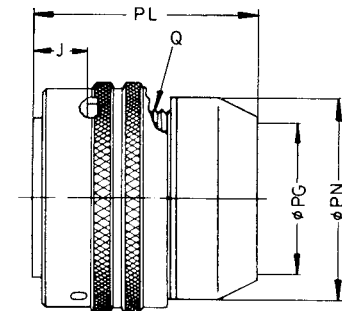

**PT 06 SE ... SP**  
(MS 3126 P)

Ordering example **PT 06 SE 14-19 W SR** see p. 70

Dimensions in mm

Shell size	EL	ø EN	ø FG	FL	FN	ø G	GC	ø GG	ø GH	GL	ø GN	J	ø JG	JL	ø JN	ø PG	PL	ø PN	Thread Q Class 2 A (inch)	SW -0.2
	max.	max.	±0.25	max.	max.	max.	max.	+0.2	-0.5	max.	±0.2	±0.25	+0.1	max.	max.	min.	max.	max.		
8	33.73	14.22	3.18	48.82	21.02	19.05	—	—	—	—	—	8.97	7.9	37	15.6	8.05	44.45	15.44	0.4375-28 UNEF	—
10	33.73	17.40	4.78	48.82	22.63	21.82	37.5	8.0	12.0	46	18	8.97	10.9	37	18.4	11.02	44.45	18.64	0.5625-24 NEF	16
12	33.73	20.65	7.92	48.82	25.81	26.19	37.5	11.0	15.0	46	21	8.97	13.8	37	23.7	13.92	44.45	21.79	0.6875-24 NEF	19
14	33.73	23.62	9.53	48.82	28.98	29.36	37.5	14.4	18.3	46	24	8.97	16.9	37	24.5	17.09	44.45	24.99	0.8125-20 UNEF	22
16	33.73	26.85	12.70	50.80	30.56	32.54	37.5	17.4	21.5	46	27	8.97	20.1	39	29.8	20.27	44.45	28.19	0.9375-20 UNEF	25
18	33.73	29.85	15.88	50.80	37.31	35.33	37.5	19.8	24.0	46	30	8.97	22.7	39	32.0	22.83	44.45	31.34	1.0625-18 NEF	28
20	32.94	33.05	15.88	53.57	37.31	38.89	39.0	21.9	27.2	50	34	10.54	25.9	42	36.1	26.01	44.45	34.54	1.1875-18 NEF	32
22	32.94	36.27	19.05	53.57	42.06	42.06	39.0	25.2	30.5	50	37	10.54	29.0	42	38.5	29.18	44.45	37.69	1.3125-18 NEF	35
24	34.52	38.94	20.32	55.17	44.45	45.14	41.0	28.0	33.5	51.5	40	10.54	32.2	42	41.5	32.36	44.86	40.89	1.4375-18 NEF	38

Assembly instructions p. 60-68.

## Straight plug PT 06 SE

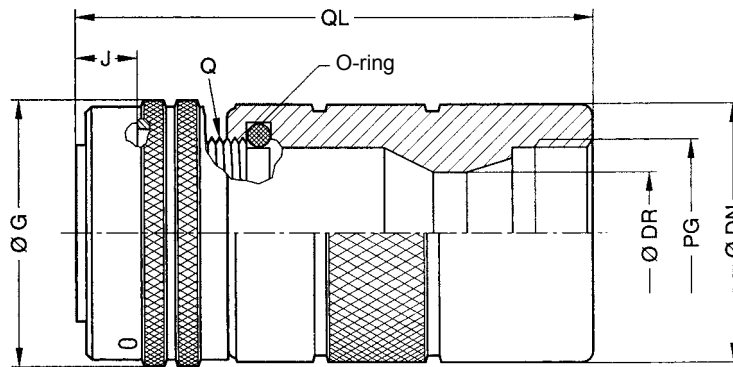

Ordering example      PT 06 SE 14-19 P W PG      see p. 70

Dimensions in mm

Size	DN + 0.5 - 0.5	DR + 0.5	J ± 0.25	QL max.	Q Thread UNEF-2A	PG Thread	ø G max.
8	15.5	6.5	8.97	57	7/16 - 28	PG 07	19.05
10	18.5	9.5	8.97	57	9/16 - 24	PG 09	21.82
12	21.5	11.0	8.97	62	11/16 - 24	PG 11	26.19
14	24.5	13.0	8.97	62	13/16 - 20	PG 13.5	29.36
16	27.5	15.5	8.97	62	15/16 - 20	PG 16	32.54
18	30.6	15.5	8.97	62	1 1/16 - 18	PG 16	35.33
20	33.5	20.5	10.54	70	1 3/16 - 18	PG 21	38.89
22	36.5	20.5	10.54	70	1 5/16 - 18	PG 21	42.06
24	40.0	20.5	10.54	72	1 7/16 - 18	PG 21	45.14

Assembly instructions p. 60-68.

## Straight plug PT 06 SE (HF-sealed)

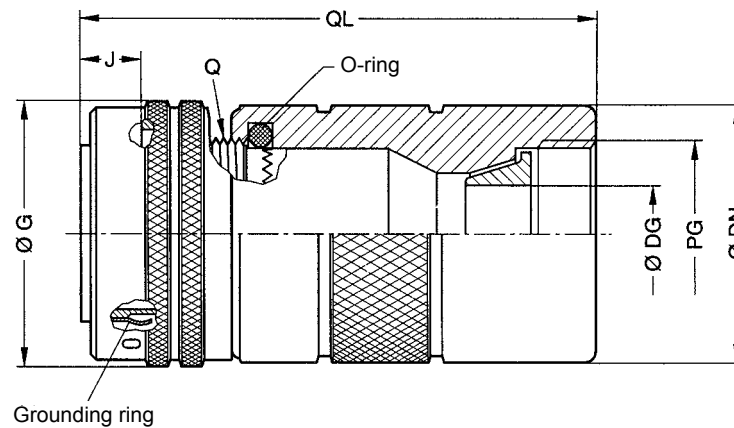

Ordering example PT 06 SE 14-19 P W <sup>Suffix</sup> PGV see p. 70

Dimensions in mm

Size	DN	DG	J	QL	Q	PG	ø G	Suffix
	+ 0.5 - 0.5	+ 0.5	± 0.25	max.	Thread UNEF-2A	Thread	max.	
8	15.5	4.5	8.97	57	7/16-28	PG 07	19.05	- PGV
10	18.5	5.5	8.97	57	9/16-24	PG 09	21.82	- PGV
12	21.5	8.5	8.97	62	11/16-24	PG 11	26.19	- PGV
14	24.5	10.5	8.97	62	13/16-20	PG 13.5	29.36	- PGV
14	24.5	8.5	8.97	62	13/16-20	PG 13.5	29.36	- PGS
16	27.5	12.5	8.97	62	15/16-20	PG 16	32.54	- PGV
16	27.5	10.5	8.97	62	15/16-20	PG 16	32.54	- PGS
18	30.6	12.5	8.97	62	1 1/16-18	PG 16	35.33	- PGV
18	30.6	10.5	8.97	62	1 1/16-18	PG 16	35.33	- PGS
20	33.5	18.5	10.54	70	1 3/16-18	PG 21	38.89	- PGV
20	33.5	12.5	10.54	70	1 3/16-18	PG 21	38.89	- PGS
22	36.5	18.5	10.54	70	1 5/16-18	PG 21	42.06	- PGV
22	36.5	12.5	10.54	70	1 5/16-18	PG 21	42.06	- PGS
24	40.0	18.5	10.54	72	1 7/16-18	PG 21	45.14	- PGV
24	40.0	12.5	10.54	72	1 7/16-18	PG 21	45.14	- PGS

Assembly instructions p. 60-68.

## HF sealed connectors

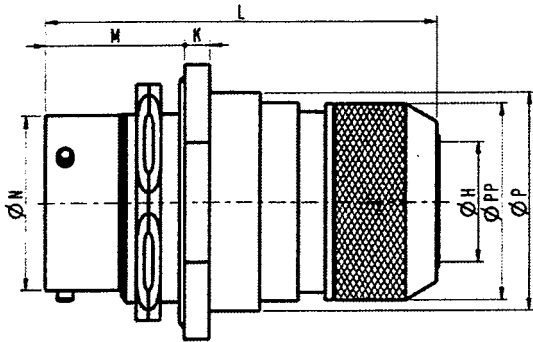

**PT 07 SE ... SQ**  
(VG 95328 T)

Shell size	M	K	ø H	ø PP	ø P	ø N	L
	+0.8 0	±0.5			max.		max.
8	17.5	3.0	6.7	16	18.5	12.01	62
10			9.2	18	21.6	14.99	
12			12.2	22	24.8	19.05	
14			15.2	25	28.0	22.23	
16			18.3	28	31.2	25.40	
18			20.0	32	34.3	28.58	
20	22.3	3.8	23.0	34	38.3	31.75	
22			26.0	38	41.5	34.93	
24			28.8	41	44.7	38.10	

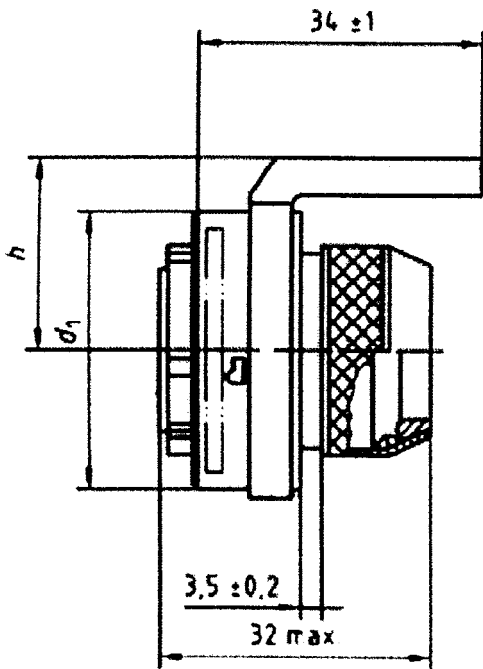

Shell size	d1	h
	±1	±1
12	24	19
14	28	20
16	31	21

**PTU 06 SE ... SQ**  
(VG 95328 U)

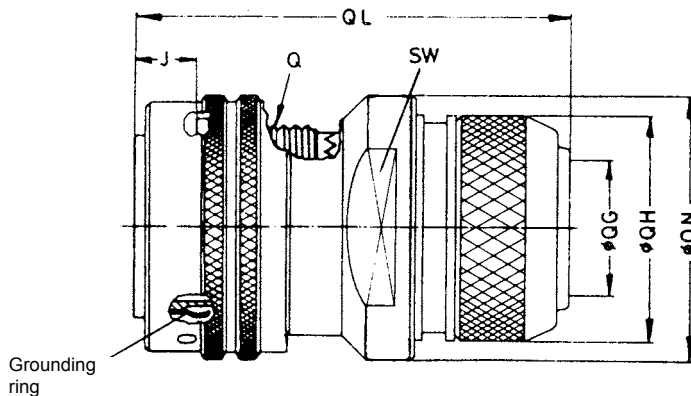

**PTG 06 SE ... SQ**  
(VG 95328 M)

Shell size	J	ø QG	ø QH	QL	ø QN	SW
	±0.25	min.	+0.5	max.	max.	-0.2
8	8.97	6.7	16	51	20	18
10	8.97	9.2	18	51	23	21
12	8.97	12.2	22	54	27	24
14	8.97	15.2	25	54	30	28
16	8.97	18.3	28	54	33	31
18	8.97	20	32	54	36	34
20	10.54	23	34	56	40	37
22	10.54	26	38	56	43	41
24	10.54	28.8	41	58	48	44

Assembly instructions p. 60-68.

## Angle plug PT 08 SE

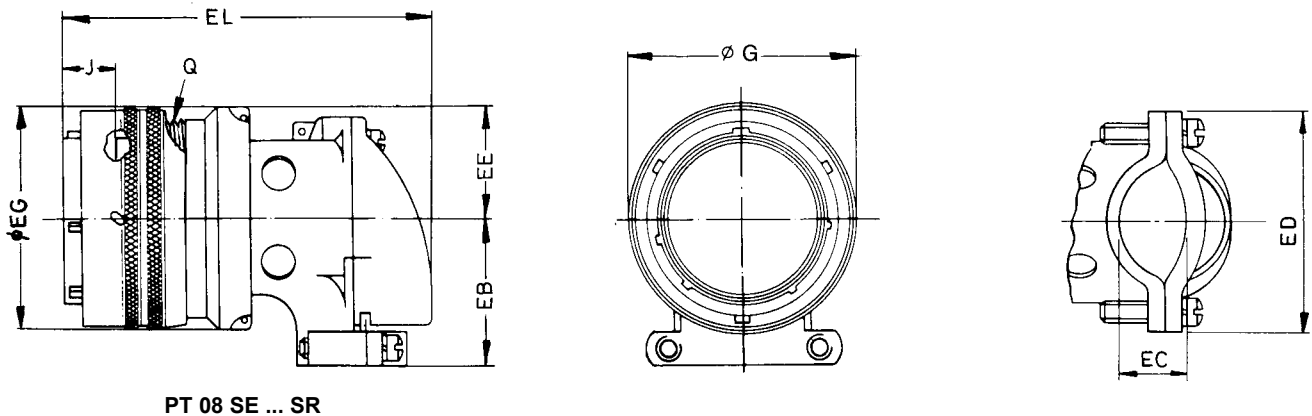

Ordering example PT 08 SE 14-19 P W SR see p. 70

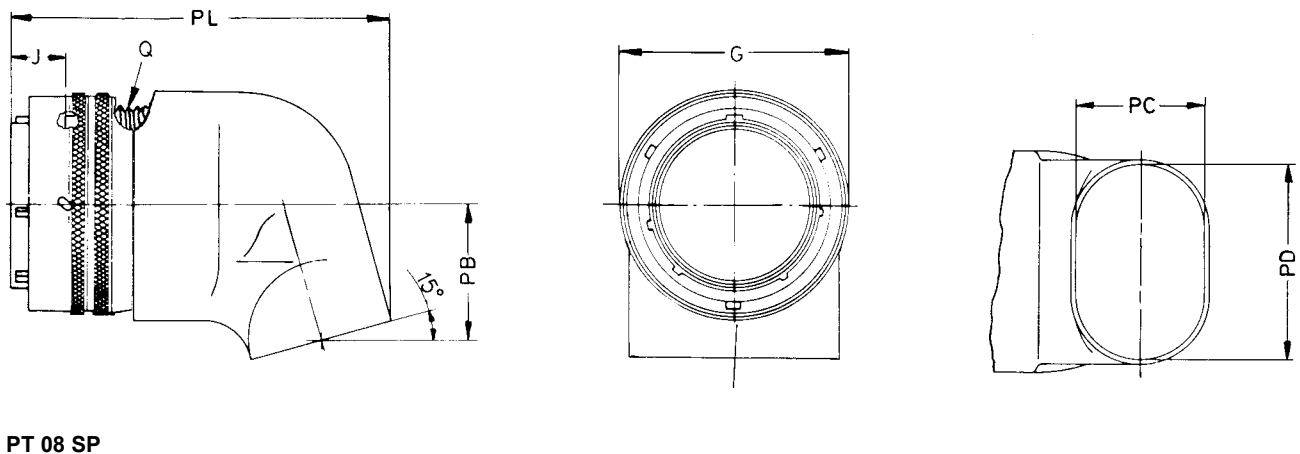

Ordering example PT 08 SP 14-19 P W see p. 70

### Dimensions in mm

Shell size	EB	EC	ED	EE	ø EG	EL	ø G	J	PB	PC	PO	PL	Thread Q
	± 0.79	+ 0.25 - 0.64	± 1.57	+ 1.19 - 0.64	max.	max.	max.	± 0.25	max.	± 0.38	± 0.38		Class 2A (inch)
8	16.64	3.96	23.90	8.61	20.21	53.00	19.05	8.97	11.00	7.92	11.13	47.0	0.4375-28 UNEF
10	19.02	4.32	30.25	9.98	23.39	54.28	21.82	8.97	12.52	11.13	14.27	50.0	0.5625-24 NEF
12	20.62	6.71	30.25	11.43	26.57	56.44	26.19	8.97	14.02	13.11	17.48	52.0	0.6875-24 NEF
14	22.99	7.87	31.85	13.18	29.74	60.20	29.36	8.97	16.33	15.88	19.84	55.0	0.8125-20 UNEF
16	26.16	8.38	33.43	14.81	32.94	65.33	32.54	8.97	16.71	16.66	22.61	56.0	0.9375-20 UNEF
18	25.78	11.28	39.67	15.77	36.12	68.07	35.33	8.97	17.50	17.86	25.40	57.0	1.0625-18 NEF
20	27.38	12.95	41.28	17.35	39.67	69.93	38.89	10.54	19.05	19.46	28.58	64.0	1.1875-18 NEF
22	28.93	13.08	43.66	18.77	42.47	71.09	42.06	10.54	20.17	20.62	31.34	65.0	1.3125-18 NEF
24	31.75	16.66	44.45	20.24	45.64	77.14	45.14	10.54	27.18	23.32	34.90	74.0	1.4375-18 NEF

Assembly instructions p. 60-68.



**CRIMP CONTACTS**



Connector	Order code			
	Pin contact		Socket contact	
	With cup	Without cup	With cup	Without cup
20	42966-903		42969-903	
16	–	39819-903	–	39827-903
		VG designation		
20	VG 95328-P20C	–	VG 95328 S20 C	–
16	–	VG 95328 P16	–	VG 95328 S16

**Crimp coaxial contacts**

Contact size	Usable with cable	Order code	
		Pin contact	Socket contact
16	M 17/094/RG 179 1 } M 17/113/RG 316 J }	21-33656-1	21-33655-1

**Sealing plug**

Sealing plug size	Color code	Order code	
		Order No.	MS/DIN
20	red	10-405 996-202	MS 27488-20-2
16	green	10-405 996-162	MS 27488-16-2

The sealing plugs shown above are used for sealing unused contact openings.

Technical data see p. 5

Assembly instructions p. 60-68.



**Dummy**  
**10-263999**  
(MS 3115)  
VG 95328 T07 C XX

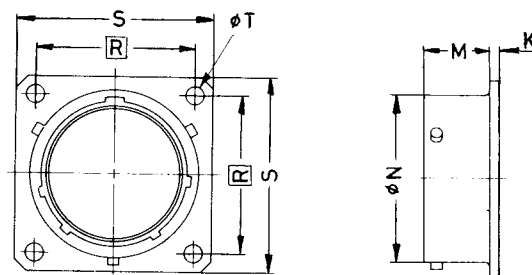

Shell size	Order number	Dimensions in mm					
		K ± 0.41	M + 0.79	∅ N + 0.03 - 0.13	R Theoret. dimensions	S max.	T ± 0.13
08	10-263999-083	1.57	11.73	12.01	15.09	21.03	3.05
10	10-263999-103	1.57	11.73	14.99	18.26	24.23	3.05
12	10-263999-123	1.57	11.73	19.05	20.62	26.59	3.05
14	10-263999-143	1.57	11.73	22.23	23.01	28.98	3.05
16	10-263999-163	1.57	11.73	25.40	24.61	31.34	3.05
18	10-263999-183	1.57	11.73	28.58	26.97	33.73	3.05
20	10-263999-203	2.39	14.12	31.75	29.36	36.91	3.05
22	10-263999-223	2.39	14.12	34.93	31.75	40.08	3.05
24	10-263999-243	2.39	14.96	38.10	34.93	43.26	3.73

**Flange gasket**

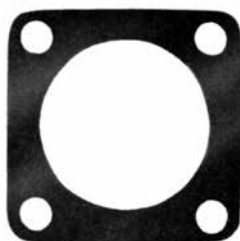

**Without metal reinforcement**  
**10-101949-XX**  
(VG 95328 T07 A)

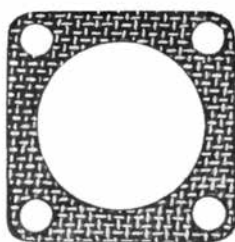

**With metal reinforcement**  
**10-40450-XX S-AT**  
(VG 95328 T07 B)

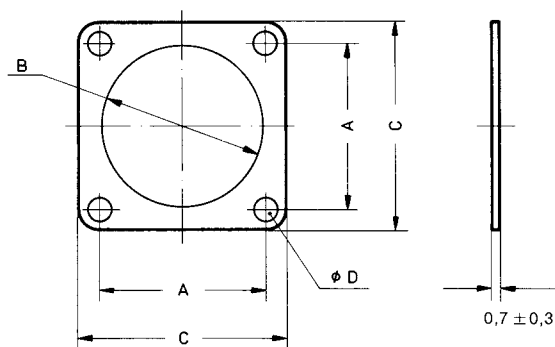

Shell size	Order number flange gasket		Dimensions in mm			
	Without shielding braid	With shielding braid	A ± 0.3	∅ B + 1	C max.	∅ D min.
08	10-101949-08	10-40450-08S-AT	15.1	12.7	22.7	3.0
10	10-101949-10	10-40450-10S-AT	18.3	15.9	25.8	3.0
12	10-101949-12	10-40450-12S-AT	20.6	19.0	28.2	3.0
14	10-101949-14	10-40450-14S-AT	23.0	22.2	30.6	3.0
16	10-101949-16	10-40450-16S-AT	24.6	25.4	33.0	3.0
18	10-101949-18	10-40450-18S-AT	27.0	28.6	35.4	3.0
20	10-101949-20	10-40450-20S-AT	29.4	31.7	38.5	3.0
22	10-101949-22	10-40450-22S-AT	31.8	34.9	41.7	3.0
24	10-101949-24	10-40450-24S-AT	34.9	38.1	44.9	4.2

Assembly instructions p. 60-68.

**Angular potting boot  
(75°)  
10-101988**

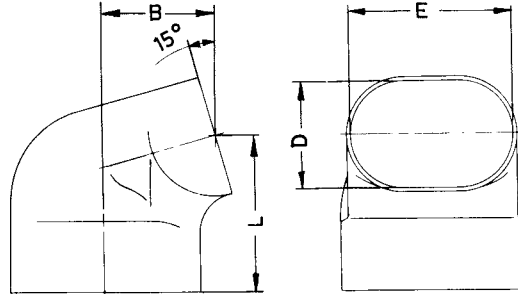

Shell size	Order number	Dimensions in mm			
		B max.	D ± 0.38	E ± 0.38	L max.
08	42806-011	11.00	07.92	11.13	19.46
10	42806-012	12.52	11.13	14.27	21.08
12	42806-013	14.02	13.11	17.48	21.87
14	42806-014	16.33	15.88	19.84	23.27
16	42806-015	16.71	16.66	22.61	23.77
18	42806-016	17.50	17.86	25.40	24.36
20	42806-017	19.05	19.46	28.58	26.72
22	42806-018	20.18	20.62	31.34	27.25
24	42806-019	27.18	23.32	34.90	33.27

The angular potting cap (75°) can be used for sealing wire bundles if angulation is desired.



**Plastic dust cap  
37024**

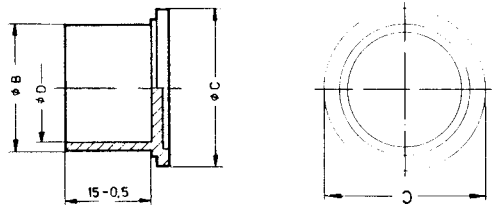

Dimensions in mm

Shell size	Order code (for plugs)	Dimensions in mm		
		ø B - 0.2	ø C ± 0.2	ø D - 0.2
08	S 8	12.0	16.0	10.0
10	D 8 S 10	15.0	20.0	13.0
12	D 10 S 12	18.3	23.0	16.3
14	D 12 S 14	21.5	27.0	19.5
16	D 14 S 16	25.0	29.5	23.0
18	D 16 S 18	27.7	32.0	25.7
20	D 18 S 20	30.9	35.5	28.9
22	D 20 S 22	34.1	39.0	32.1
24	D 22 S 24	37.3	42.0	35.3

Shell size	Order code (for receptacles)	Dimensions in mm		
		ø B - 0.2	ø C ± 0.2	ø D - 0.2
08	D 8 S 10	15.0	20.0	13.0
10	D 10 S 12	18.3	23.0	16.3
12	D 12 S 14	21.5	27.0	19.5
14	D 14 S 16	25.0	29.5	23.0
16	D 16 S 18	27.7	32.0	25.7
18	D 18 S 20	30.9	35.5	28.9
20	D 20 S 22	34.1	39.0	32.1
22	D 22 S 24	37.3	42.0	35.3
24	D 24	42.0	46.0	40.0

The dust caps protect the contacts during shipping and storage.



**Metal protective cap**  
for receptacles with rectangular flange

VG 95328 Z1 A  
VG 95328 Z1 B

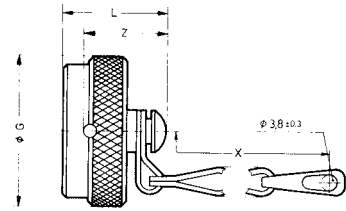

Shell size	Order number				Dimensions in mm			
	With link chain (MS 3181C) Amphenol designation	With link chain VG designation	With nylon cord Amphenol designation	With nylon cord VG designation	∅ G max.	L max.	X + 13 - 7	Z max.
08	38822-071	VG 95328 Z1 A 08	51546-061	VG 95328 Z1 B 08	18.65	21.5	77	17.5
10	38822-072	VG 95328 Z1 A 10	51546-062	VG 95328 Z1 B 10	21.82	21.5	77	17.5
12	38822-073	VG 95328 Z1 A 12	51546-063	VG 95328 Z1 B 12	25.50	21.5	89	17.5
14	38822-074	VG 95328 Z1 A 14	51546-064	VG 95328 Z1 B 14	28.58	21.5	89	17.5
16	38822-075	VG 95328 Z1 A 16	51546-065	VG 95328 Z1 B 16	31.75	21.5	89	17.5
18	38822-076	VG 95328 Z1 A 18	51546-066	VG 95328 Z1 B 18	34.93	21.5	89	17.5
20	38822-077	VG 95328 Z1 A 20	51546-067	VG 95328 Z1 B 20	38.10	21.5	102	17.5
22	38822-078	VG 95328 Z1 A 22	51546-068	VG 95328 Z1 B 22	41.28	21.5	102	17.5
24	38822-079	VG 95328 Z1 A 24	51546-069	VG 95328 Z1 B 24	44.45	22.3	102	20.0

The protective cap is attached to one of the receptacle flange screws by means of a chain link or grommet.  
The protective cap is fitted with a seal which guarantees watertight sealing between the cap and the receptacle.

VG 95328 Z1 C



Case

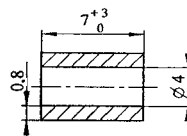

Terminal unit

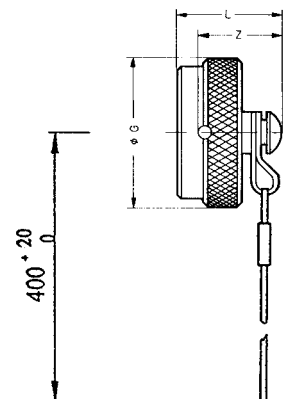
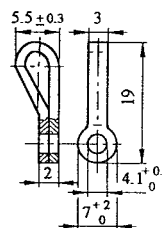

Shell size	Order number		Dimensions in mm		
	With nylon cord Amphenol designation	With nylon cord VG designation	∅ G max.	L max.	Z max.
08	38828-071	VG 95328 Z1 C 08	18.65	21.5	17.5
10	38828-072	VG 95328 Z1 C 10	21.82	21.5	17.5
12	38828-073	VG 95328 Z1 C 12	25.50	21.5	17.5
14	38828-074	VG 95328 Z1 C 14	28.58	21.5	17.5
16	38828-075	VG 95328 Z1 C 16	31.75	21.5	17.5
18	38828-076	VG 95328 Z1 C 18	34.93	21.5	17.5
20	38828-077	VG 95328 Z1 C 20	38.10	21.5	17.5
22	38828-078	VG 95328 Z1 C 22	41.28	21.5	17.5
24	38828-079	VG 95328 Z1 C 24	44.45	22.3	20.0

The sleeve is used to fix the terminal unit to the rope. Sleeve and terminal unit are delivered unassembled.  
The user can therefore set the desired rope length.

## Accessories



**Metal protective cap**  
for cable connecting plugs

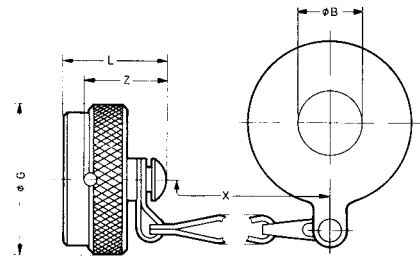

Shell size	Order number		Dimensions in mm				
	With link chain	With nylon cord	$\varnothing B + 0.25$ 0	$\varnothing G$ max.	L max.	X min.	Z max.
08	38823-071	38830-071	11.53	18.65	21.5	70	17.5
10	38823-072	38830-072	14.68	21.82	21.5	70	17.5
12	38823-073	38830-073	17.86	25.50	21.5	70	17.5
14	38823-074	38830-074	21.44	28.58	21.5	70	17.5
16	38823-075	38830-075	24.61	31.75	21.5	70	17.5
18	38823-076	38830-076	27.79	34.93	21.5	70	17.5
20	38823-077	38830-077	30.96	38.10	21.5	70	17.5
22	38823-078	38830-078	34.11	41.28	21.5	70	17.5
24	38823-079	38830-079	36.91	44.45	22.3	70	20.0

The fastening ring of the protective cap is mounted between the cable connecting plug and the backshell. The protective cap is fitted with a seal which guarantees watertight sealing between the protective cap and the connector.



**Metal protective cap**  
Receptacle for single hole mounting  
VG 95328 Z3 C

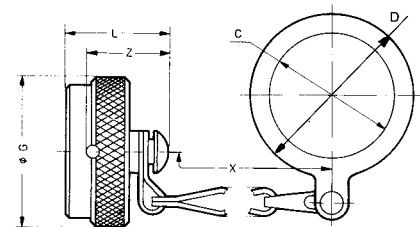

Shell size	Order number			Dimensions in mm					
	With link chain (MS 3181 N) (VG 95328 Z3 alt) Amphenol designation	With nylon cord Amphenol designation	With nylon cord VG designation	$\varnothing C$ 0 min.	$\varnothing G$ max.	L max.	X min.	Z max.	D max.
08	38824-071	38826-071	VG 95328 Z3 C 08	14.68	18.65	21.5	70	17.5	20.62
10	38824-072	38826-072	VG 95328 Z3 C 10	17.86	21.82	21.5	70	17.5	25.40
12	38824-073	38826-073	VG 95328 Z3 C 12	22.63	25.50	21.5	70	17.5	30.18
14	38824-074	38826-074	VG 95328 Z3 C 14	25.81	28.58	21.5	70	17.5	36.53
16	38824-075	38826-075	VG 95328 Z3 C 16	28.98	31.75	21.5	70	17.5	39.67
18	38824-076	38826-076	VG 95328 Z3 C 18	32.16	34.93	21.5	70	17.5	42.88
20	38824-077	38826-077	VG 95328 Z3 C 20	35.33	38.10	21.5	70	17.5	46.02
22	38824-078	38826-078	VG 95328 Z3 C 22	38.51	41.28	21.5	70	17.5	49.23
24	38824-079	38826-079	VG 95328 Z3 C 24	41.68	44.45	22.3	70	20.0	52.37

The fastening ring of the protective cap attaches the cap to the receptacle. The protective cap is fitted with a seal which enables watertight sealing between the cap and the receptacle.



**Metal protective cap**  
(for plugs)

VG 95328 Z2 A  
VG 95328 Z2 B

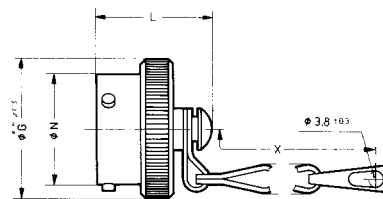

Shell size	Order number				Dimensions in mm			
	With link chain (MS 3180C) Amphenol designation	With link chain VG designation	With nylon cord Amphenol designation	With nylon cord VG designation	∅ G max.	L max.	∅ N + 0.03 - 0.13	X + 13 - 7
08	42167-061	VG 95328 Z2 A 08	52152-061	VG 95328 Z2 B 08	18.27	20	12.01	77
10	42167-062	VG 95328 Z2 A 10	52152-062	VG 95328 Z2 B 10	21.44	20	14.99	77
12	42167-063	VG 95328 Z2 A 12	52152-063	VG 95328 Z2 B 12	25.50	20	19.05	89
14	42167-064	VG 95328 Z2 A 14	52152-064	VG 95328 Z2 B 14	28.58	20	22.23	89
16	42167-065	VG 95328 Z2 A 16	52152-065	VG 95328 Z2 B 16	31.75	20	25.40	89
18	42167-066	VG 95328 Z2 A 18	52152-066	VG 95328 Z2 B 18	34.93	20	28.58	89
20	42167-067	VG 95328 Z2 A 20	52152-067	VG 95328 Z2 B 20	38.10	21	31.75	102
22	42167-068	VG 95328 Z2 A 22	52152-068	VG 95328 Z2 B 22	41.28	21	34.93	102
24	42167-069	VG 95328 Z2 A 24	52152-069	VG 95328 Z2 B 24	44.45	22	38.10	102

A chain link/grommet attaches the protective cap. The protective cap is fitted with a seal which guarantees watertight sealing between the plug and the cap. The VG 95328 protective cap is equivalent to the protective cap MS 3180C. Other fastening types are available. Please send inquiry. The protective cap is also available with wire rope.

VG 95328 Z2 C

Sleeve

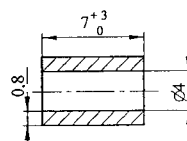

Terminal unit

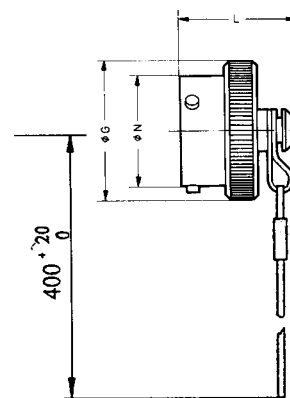
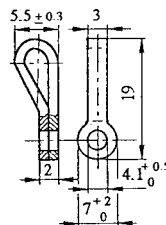

Shell size	Order number		Dimensions in mm		
	With nylon cord Amphenol designation	With nylon cord VG designation	∅ G max.	L max.	∅ N + 0.03 - 0.13
08	42169-061	VG 95328 Z2 C 08	18.27	20	12.01
10	42169-062	VG 95328 Z2 C 10	21.44	20	14.99
12	42169-063	VG 95328 Z2 C 12	25.50	20	19.05
14	42169-064	VG 95328 Z2 C 14	28.58	20	22.23
16	42169-065	VG 95328 Z2 C 16	31.75	20	25.40
18	42169-066	VG 95328 Z2 C 18	34.93	20	28.58
20	42169-067	VG 95328 Z2 C 20	38.10	21	31.75
22	42169-068	VG 95328 Z2 C 22	41.28	21	34.93
24	42169-069	VG 95328 Z2 C 24	44.45	22	38.10

The sleeve is used to fix the terminal unit to the rope. Sleeve and terminal unit are delivered unassembled. The user can therefore set the desired rope length.

**Crimp tool MS 3191-1**

(4-notch crimping)



Crimp tool	Order code		Color code	Contact size	Wire size AWG
	Crimp insert (positioner)				
MS 3191-1 = incl. inserts	MS 3191-12 A		yellow	12	12 to 14
MS 3191-A = without inserts	MS 3191-16 A		blue	16	16 to 20
	MS 3191-20 A		red	20	20 to 24

**Crimp tool M 22520/1-01**

(8-notch crimping)



Crimp tool	Order code		Color code	Contact size	Wire size AWG
	Crimp insert (turret)				
M 22520/1-01	M 22520/1-02		yellow	12	12 to 14
			blue	16	16 to 20
			red	20	20 to 24

This tool allows the setting of eight different crimping depths depending on contact and wire size. Crimp tool and crimp insert must be ordered separately.

Assembly instructions p. 60-68.



Contact installation tool 11-7401

VG/MS-designation	Order number	Contact size
M 81969/17-05	11-7401-12	12
M 81969/17-04	11-7401-16	16
M 81969/17-03	11-7401-20	20



Contact removal tool 11-7880

VG/MS-designation	Order number	Contact size
M 81969/19-02 RevB	11-7880-12	12
M 81969/19-01 RevB	11-7880-16	16
M 81969/19-06 RevB	11-7880-20	20

Assembly instructions p. 60-68.

## Backshell mounting

These assembly instructions contain the most important steps of the installation. Our sales team is always ready to answer any questions you may have regarding wiring, assembly, and installation of connectors.

**Backshell »A« SR.** Place the backshell over the wire bundles. Strip the conductor (see p. 5 stripping length), tin-plate and solder to the contacts. Screw the backshell to the connector.

**Backshell »A« SR.** Place the rubber grommet and cable clamp over wire bundle. Strip the conductor (see p. 5 stripping length) and solder to the contacts. Screw the cable clamp to connector, insert the rubber grommet into the cable clamp and tighten the screws.

**Backshell »E«.** Place the coupling ring and cable clamp over wire bundle. Push single wires through the holes in the sealing insert, strip (see p. 5) and solder to the contacts. Place sealing inserts over solder connections. Place sealing plugs in unused seals (see p. 52). Push the clamping ring onto the sealing insert and screw the coupling ring onto the connector. The sealing insert should protrude somewhat over the ring.

**Backshell »E« SR.** Place the rubber grommet, cable clamp and clamping ring over wire bundle. Push single wires through holes in the sealing insert, strip (see p. 5) and solder to the contacts. Place the sealing insert over the solder connections, push the clamping ring onto the sealing insert and screw the cable clamp onto the connector. Place sealing plugs in unused seals (see p. 52). Place rubber grommet in the cable clamp and fasten the screws.

**Backshells »E« J.** Place backshell and clamping ring over wire bundle. Push single wires through the holes in the sealing insert, strip (see p. 5) and solder to the contacts. Place sealing inserts over solder connections. Place sealing plugs in unused seals (see p. 52), push clamping ring onto sealing insert. Screw the backshell to the connector. Attach suitable heat shrink tubing.

**Backshell »P«.** Place backshell over cable, strip single wires (see p. 5) and solder to contacts. Screw potting boot to the connector. Pot the wire bundle following the instructions from the potting compound supplier.

**Backshell »P« SR.** Pull the rubber grommet and cable clamp over wire bundle. Strip wire (see p. 5) and solder to the contacts. Screw cable clamp to the connector without strain relief. Pot the wire bundle following the instructions from the potting compound supplier. Place rubber grommet in the cable clamp and fasten strain relief.

**Backshell »W«.** The following strip lengths must be observed when using jacketed multi-conductor cables:

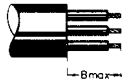
	Shell size	8 10 12 14 16 18 20 22 24
	B max. (mm)	16 16 18 21 23 28 32 35 42

Strip stranded wire to 3.2mm or 6.3mm with contact sizes of 20 and 16 respectively. Make sure that the diameter of the cable jacket is within » DW « dimensions (see page 17, 19, 23). Place the coupling ring and sealing sleeve over wire bundle. Solder single wires to contacts. Push sealing sleeve onto connector and make sure that the two cams align properly with the grooves on the connector. Screw coupling ring to the connector.

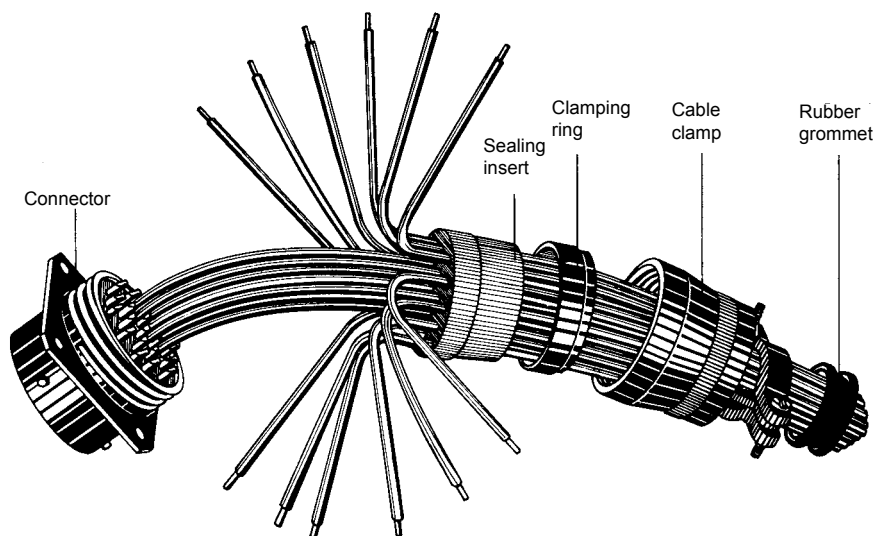

Mounting example: Connector with backshell »E« SR.

## Crimping of the contacts

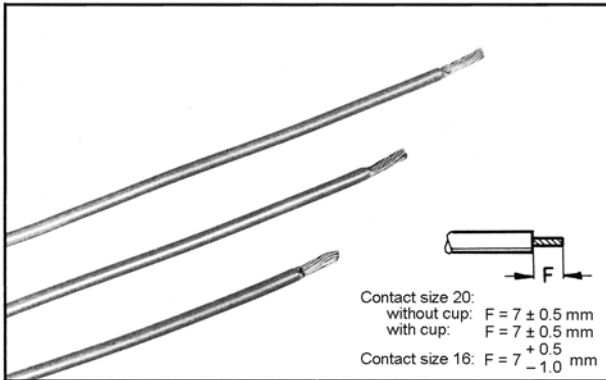

① Cut the conductor to the required length and strip following the instructions mentioned. Do not bend or cut stranded wire. Thermal insulation is recommended.

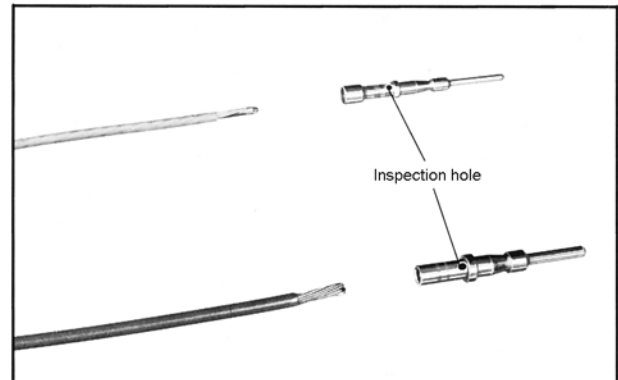

② Put stripped stranded wire into contact crimp sleeve. Make sure that the stranded wire is visible through the inspection hole.

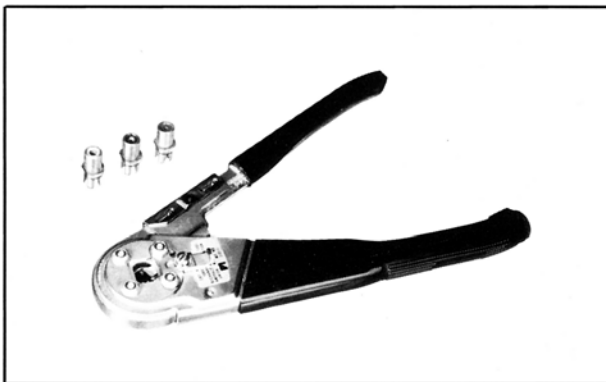

③ The crimp tool MS 3191-1 (4-notch crimping) is delivered together with several inserts. Make sure that the correct insert is chosen (see page 58). Proper crimp tool use is described in the manufacturer's instructions.

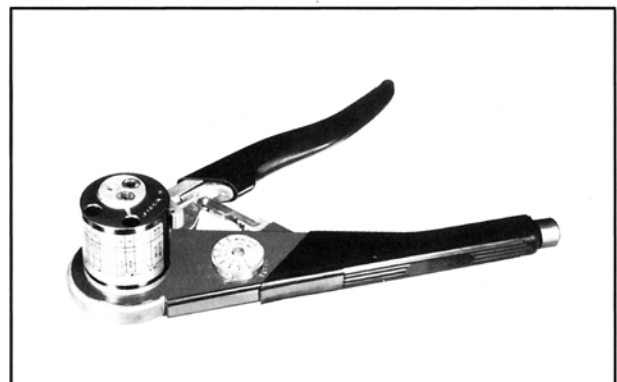

④ The crimp tool M 22520/1-01 (8-notch crimping) is equipped with a single insert (see page 58), which allows the crimping of 3 contact sizes. See also user manual provided by manufacturer.



⑤ Close and open crimp tool MS 3191-1 once before actual crimping to ensure that the jaws are open. Insert contact with conductor into receptacle. Close tool completely until it automatically reopens. Remove contact from the receptacle and check if conductor is visible through the inspection hole.



⑥ After properly setting the wire size and contact values, close and reopen tool M 22520/1-01 to ensure that the crimp jaws are open. Insert contact with the conductor into receptacle. Close tool completely until it automatically reopens. Remove contact from the receptacle and check if conductor is visible through the inspection hole.

### Insertion of contacts

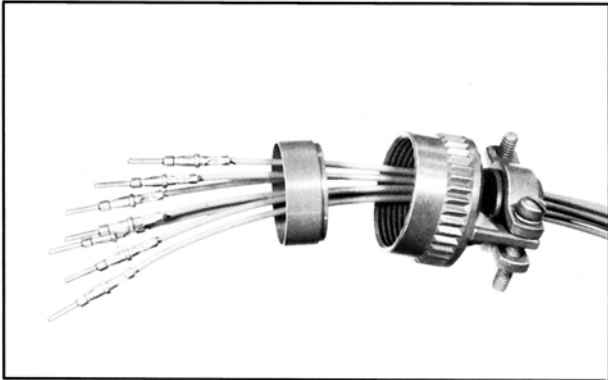

① Remove individual backshell components from the connector and place them over the wire bundles in the correct order.

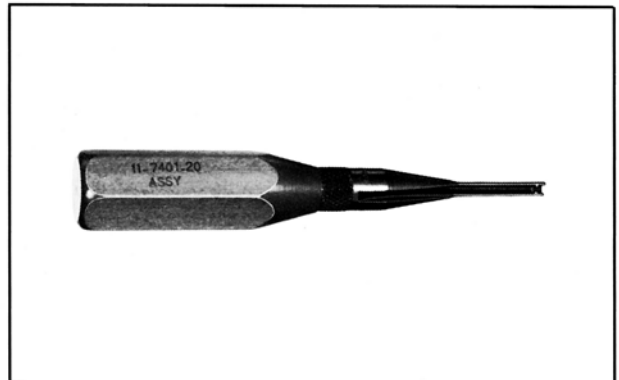

② Use tool 11-7401 to insert contacts into the connector (see page 59).

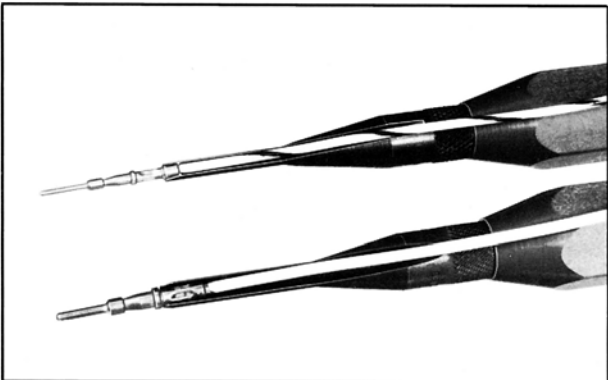

③ Place the contacts in the insertion tool (11-7401) as shown above.

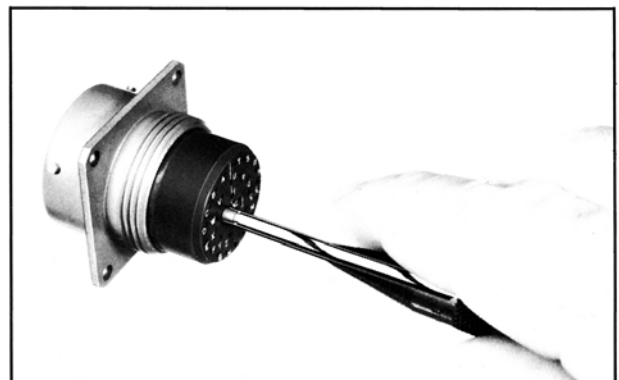

④ Insert the contact on the back of the connector lineally and press forward until it clicks into place. Remove tool. By pulling gently on the conductor, check that the contact is correctly inserted.

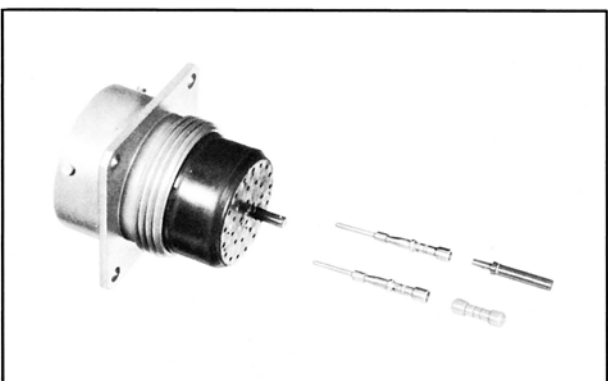

⑤ Place an uncrimped contact and a sealing plug in unused contact openings. The sealing plug must protrude from the sealing insert.



⑥ After equipping the connector, determine by visual inspection if all contacts are inserted correctly. The backshell can then be screwed on.





The contact retention system used in the connector PT-SE is a "Front Removable System", meaning the contacts must be removed from the plug side to the wiring side.

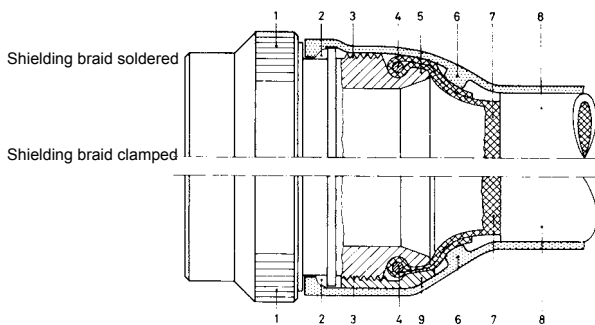

### Clamping of shielding braid

- Loosen the clamping nut (9). Place heat shrink part (6) and clamping nut over cables (8).
- Push shielding braid (7) onto backshell (1) and over the thread (3).
- Fasten shielding braid (7) to the rounded groove with binding wire (4).
- Fold the protruding shielding braid back over the cone (5).
- Screw the clamping nut (9) onto the backshell (1) (the folded shielding braid must protrude under the clamping nut on the cable side).
- Apply adhesive from the rectangular groove (2) down to the clamping nut (9).
- Shrink-fit heat shrink part (6) (the lip of the heat shrink part grips into the rectangular groove (2)).

## Removal of contacts from the connector

Place the removal tool 11-7880 over the pin or sleeve contact on the mating side of the connector and push twisting slightly until it stops. Push the pin of the tool forward. The contact is now detached and can be removed by pulling the conductor on the back of the connector. Make sure that the tool is in an axial position to the contact during insertion and removal.

In the case of contacts without wires, the sealing plug must be removed and the contact removed as described above. After extraction of the removal tool, use a suitable pin to push the contact out from the back side of the connector.

## Mounting the backshell SE . . . SQ

This backshell is used for attaching a shielding braid and a heat shrink part (see page 67) in order to meet particularly high requirements for RF sealing and coupling resistance between the cable and connector. The backshell has anti-rotation teeth which function as an anti-rotation mechanism. The shielding braid can be mounted using the following two methods.

### Soldering of the shielding braid

- Remove the clamping nut (9). It is no longer needed.
- Place heat shrink part (6) and clamping nut over cables (8).
- Tin-plate the rounded groove.
- Push shielding braid (7) onto backshell (1) and over the thread (3).
- Fasten shielding braid to the rounded groove with binding wire (4).
- Fold the protruding shielding braid back over the cone (5).
- Solder the shielding braid (7) to the rounded groove.
- Apply adhesive from the rectangular groove (2) down to the soldering point.
- Shrink-fit heat shrink part (6). The lip of the heat shrink part grips into the rectangular groove (2).

## Assembly instructions

The receptacles with rectangular flange of the series PT and PT-SE are installed on the front side of the mounting wall. With the thru-bulkhead PTB (see installation example), screw length and screw head diameters which guarantee perfect coupling must be selected. Flange gaskets see p. 53

Dimensions in mm

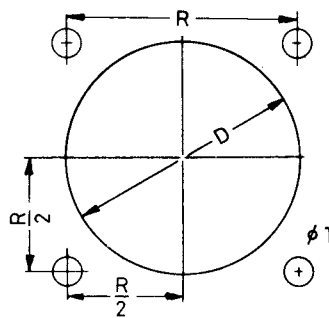

Mounting hole

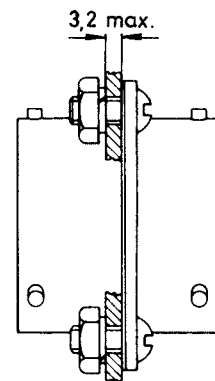

Installation example: PTB

Shell size	8	10	12	14	16	18	20	22	24
∅ D only for PTB	14.00	17.00	22.00	25.00	28.00	31.00	34.50	37.50	41.00
∅ D for PT, PT-SE	12.10	15.20	18.40	21.60	24.80	27.90	31.10	34.30	37.40
R. Theoret. dim.	15.09	18.26	20.62	23.01	24.61	26.97	29.36	31.75	34.93
∅ T min. +0.13	3.50	3.50	3.50	3.50	3.50	3.50	3.50	3.50	4.00

### Receptacles for single hole mounting

The receptacles for single hole mounting can be fixed to mounting walls with a thickness of 1.6 mm to 3.2 mm with shell sizes 8 to 18, and from 5.5 mm max. with shell sizes 20 to 24.

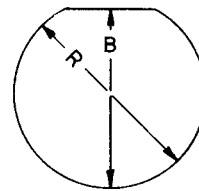

Mounting hole

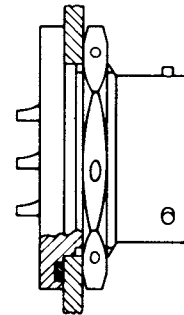

Installation example: PT 07

Dimensions in mm

Shell size	8	10	12	14	16	18	20	22	24
B - 0.25	13.77	16.99	21.08	24.26	27.53	30.68	33.86	37.06	40.01
∅ R + 0.25	14.53	17.70	22.45	25.58	28.80	31.98	35.15	38.28	41.50

### Hermetically sealed receptacle

The receptacle must be mounted in such a manner that the hermetic seal provided by the compression glass insert is maintained. The shell surface is tin-plated to facilitate soldering. Soldering tin with a low melting point is recommended. The solder is applied at the points indicated by arrows.

Dimensions in mm

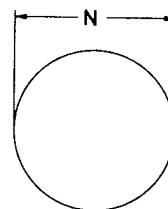

Mounting hole

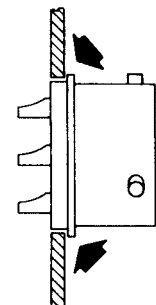

Installation example: PTIH

Shell size	8	10	12	14	16	18	20	22	24
∅ N max.	14.78	17.58	20.35	23.52	26.70	29.87	35.43	34.93	38.61



**Receptacle PT 07 SE and plug PT 06 SE**  
with backshells

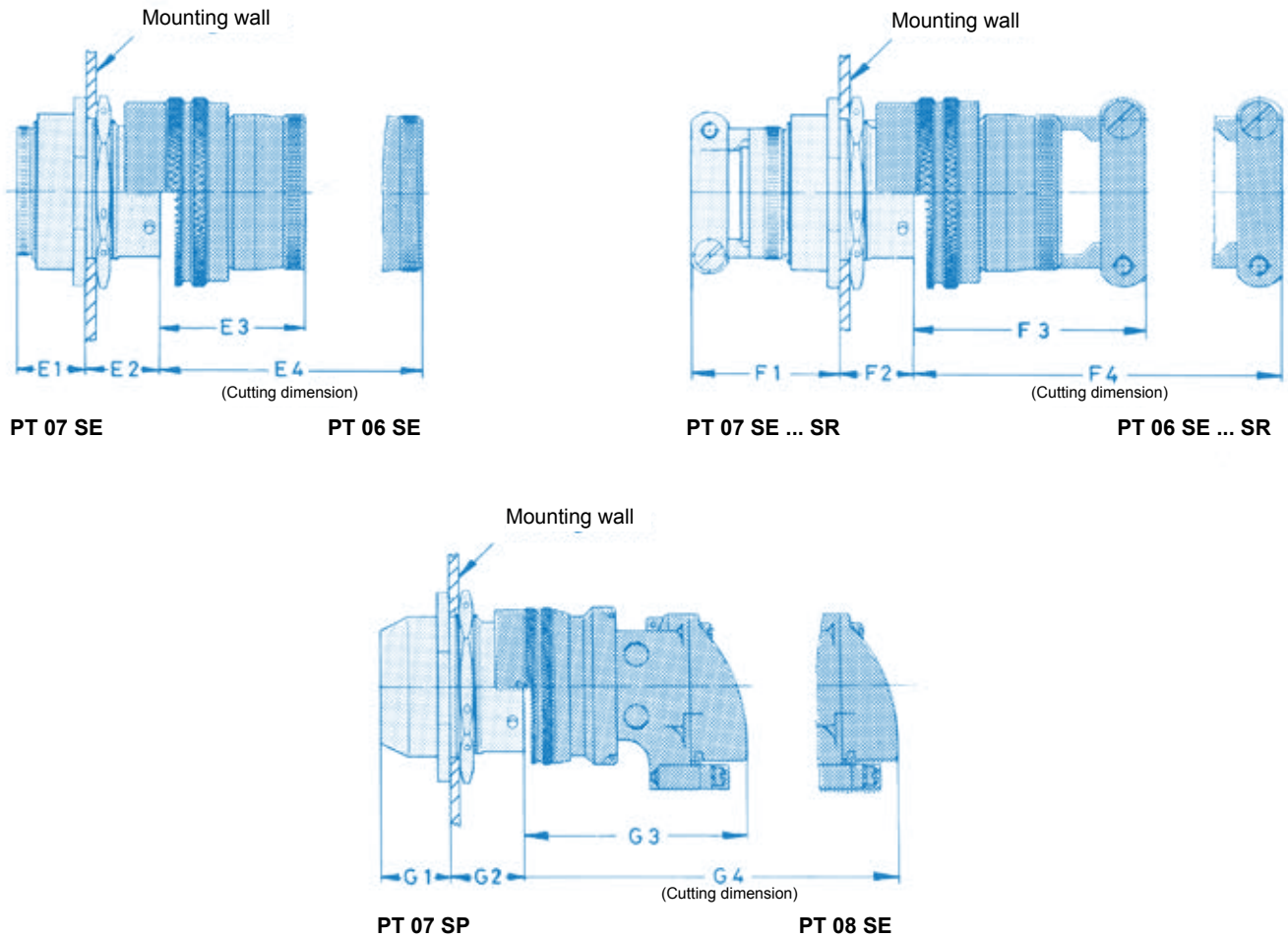

Dimensions in mm

Shell size	E1	E2	E3	E4	F1	F2	F3	F4	G1	G2	G3	G4
8	19	18	25	39	32	18	40	54	25	18	45	59
10	19	18	25	39	32	18	40	54	25	18	46	60
12	19	18	25	39	32	18	40	54	25	18	48	62
14	19	18	25	39	32	18	40	54	25	18	52	66
16	19	18	25	39	34	18	42	56	25	18	57	71
18	19	18	25	39	34	18	42	56	25	18	60	74
20	19	23	23	38	33	23	44	59	27	23	60	75
22	19	23	23	38	33	23	44	59	27	23	61	77
24	20	24	24	40	34	24	45	61	27	24	67	83

## Application examples of heat shrink parts

The heat shrink parts shown (also referred to as shrinkable parts) are suitable for shrink-fitting to fully assembled connectors which use backshells SE ... SQ or SE... F.

The molded parts 202 K and 222 K can be obtained from the RAYCHEM company. The order codes and dimensions below are for informational purposes only.

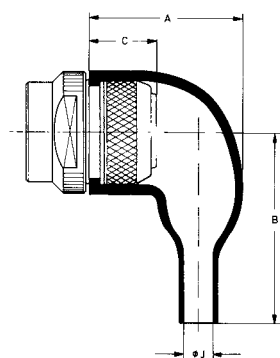

Backshell SE ... SQ with molded part 222

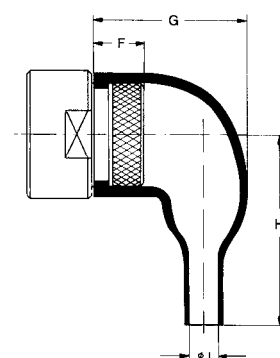

Backshell SE ... F with molded part 222

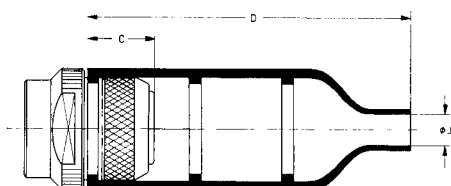

Backshell SE ... SQ with molded part 202

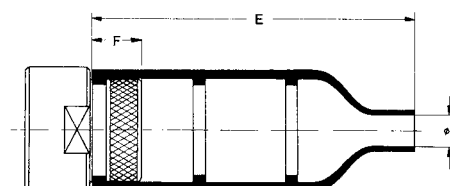

Backshells ... F with molded part 202

## Dimensions in mm

Backshell SE ... SQ

Shell size	Molded part order code	Dimensions in mm				
		A	B	C	D	ø J max.
8	222 K 121	25.4	25.0	16	38.4	5.6
	202 K 121					
10	222 K 132	27.2	32.0	17	54.9	6.6
	202 K 132					
12	222 K 132	27.2	32.0	17	54.9	6.6
	202 K 132					
14	222 K 142	30.5	39.4	17	66.8	7.1
	202 K 142					
16	222 K 152	38.0	46.4	18	80.0	8.4
	202 K 153					
18	222 K 152	38.0	46.4	18	80.0	8.4
	202 K 153					
20	222 K 163	45.0	55.0	18	99.1	9.9
	202 K 163					
22	222 K 163	45.0	55.0	18	99.1	9.9
	202 K 163					
24	222 K 174	54.0	80.0	18	130.0	15.7
	202 K 174					

Backshell SE ... F

Shell size	Molded part order code	Dimensions in mm				
		E	F	G	H	ø J max.
8	222 A 111	25.4	12	20.1	17.3	3.8
	202 A 111					
10	222 K 121	38.4	12	25.4	25.0	5.6
	202 K 121					
12	222 K 132	38.4	12	25.4	25.0	5.6
	202 K 132					
14	222 K 132	54.9	12	27.2	32.0	6.6
	202 K 132					
16	222 K 142	66.8	12	30.5	39.4	7.1
	202 K 142					
18	222 K 142	66.8	12	30.5	39.4	7.1
	202 K 142					
20	222 K 152	80.0	12	38.0	46.4	8.4
	202 K 153					
22	222 K 163	99.1	14	45.0	55.0	9.9
	202 K 163					
24	222 K 163	99.1	14	45.0	55.0	9.9
	202 K 163					

## General considerations for PG backshells with shield connection

### Standard version

- Overall shielded cable  
Shield sizes see p. 49.

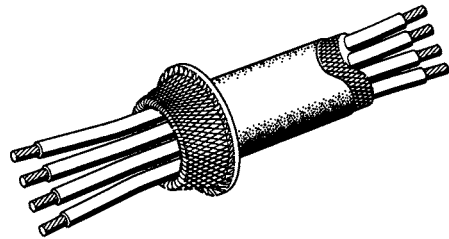
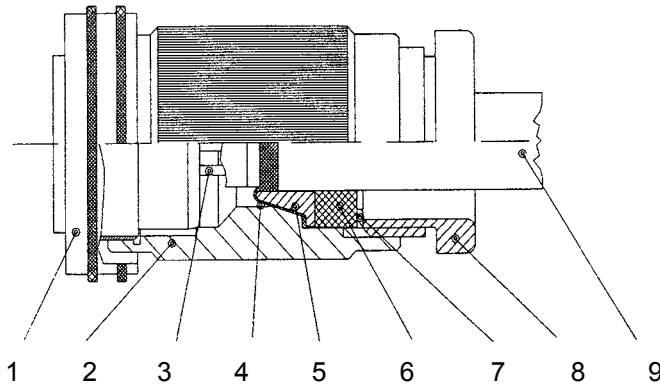

- |            |                |                   |
|------------|----------------|-------------------|
| 1) Plug    | 4) Shield      | 7) Disk           |
| 2) Adapter | 5) Cone ring   | 8) Pressing screw |
| 3) Wire    | 6) Rubber ring | 9) Cable          |

### Special versions Please send inquiry.

- Individually shielded cables  
Shielding cones must be fitted to the individual cables.

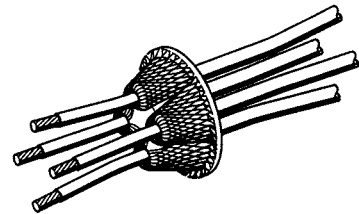
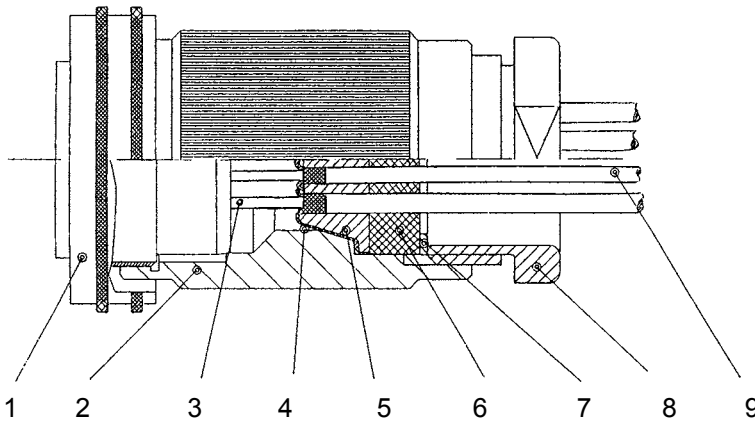

## Ordering example as per VG 95328

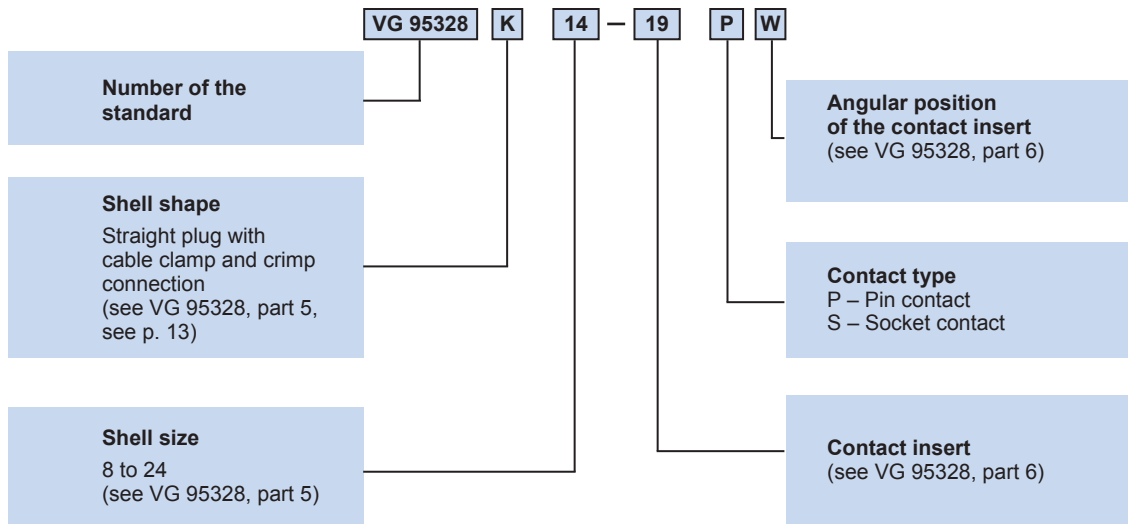

## Ordering example as per MIL-C-26482

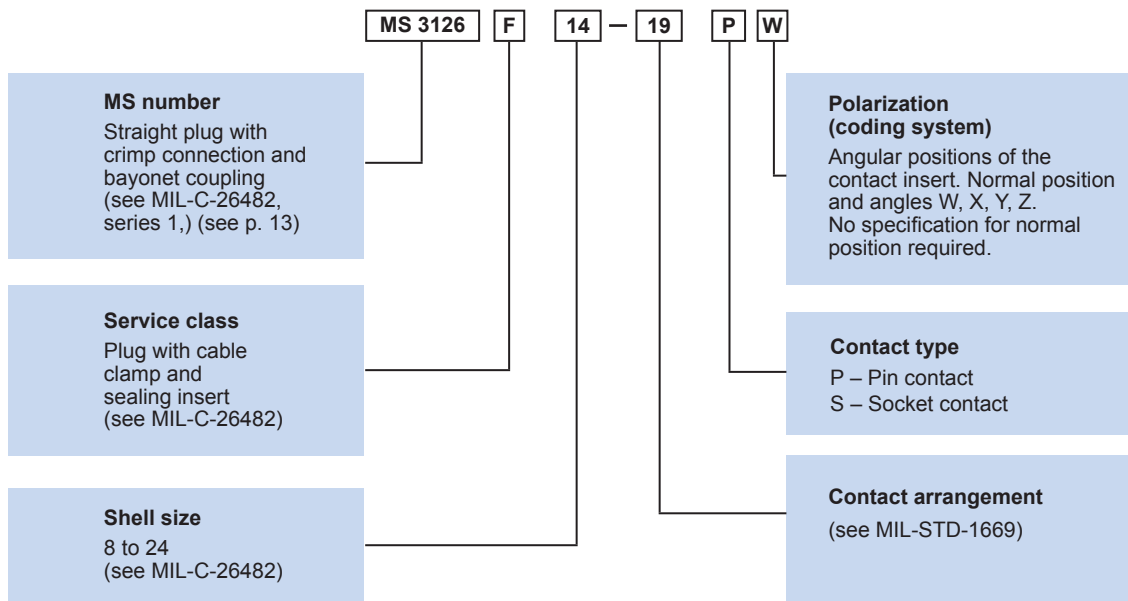

Special designs following customer specifications upon request.

# Ordering example

PT G 06 SE 14-19 P W SQ XXX

## Series

PT – Pygmy Tri-Lock  
Circular connectors with  
three pin bayonet coupling

G – grounding ring (HF-sealed)  
Only with plug PTG 06 of  
service class SE.

## Design (see 10, 11)

00 – Wall mounting receptacle  
01 – Cable connecting plug  
02 – Box mounting receptacle  
06 – Straight plug  
07 – Receptacle for single hole mount-  
ing  
08 – Angle plug  
B – Thru-bulkhead receptacle  
I – Receptacle with solder flange

## Service class (See pages 15 and 40)

### Connectors with solder connection

A – Version without special requirements.  
C – Pressure-proof version.  
Only for receptacles.  
E – Moisture-proof version.  
Pressure-proof receptacles.  
P – Similar to service class »E«,  
yet for sealing wire bundles.  
W – Similar to service class »E«,  
yet for sealing jacketed  
multi-conductor cables.  
H – Hermetically sealed version.  
GS – Version with solder contacts  
for printed circuit boards.

### Receptacles with wire-wrap connections

WW – Pressure-proof version  
with wire-wraps

### Receptacles with crimp connections

SE – Moisture-proof version.  
SP – Similar to service class »E«,  
yet for sealing wire bundles.

## Surface treatment

- WITHOUT-cadmium and green chromate coating
- CD-free alternatives
  - 023 – nickel-plated
  - 024 – galvanized (ZnCo) green
  - 025 – galvanized (ZnCo) black
- Other surface treatments upon request.

## Backshells

(See pages 15 and 40)

For the following backshells, the abbreviated designation together with service class must be indicated.

- F – Backshells for heat shrink parts (with anti-rotation mechanism)
- J – Backshell for heat shrink parts
- SQ – Backshell for shielding braids (HF-seal)
- SR – Cable clamp
- PG – Backshell with PG-thread
- PGV/ – Backshell with PG and shield connection

## Polarization (coding system) (page 6)

Angle adjustment of the contact insert:

Normal position and angle settings W, X, Y, Z.

No specification for normal position required.

## Contact type

- P – Pin contact (Pin)
- S – Socket contact (socket)

## Contact arrangement (See 7–9)

The contact arrangement is shown in the appropriate contact arrangement image. It consists of a double designation (here, 14-19), in which the first of the two numbers indicates the size of shell. The second number shows the number of contacts, with the exception of the contact arrangement image 10-98.



**Other connector series from our sales program for military, aerospace, and industrial applications:**

<b>MS u. 97</b>	as per MIL-C-5015 in standard and special designs.
<b>QWLD</b>	as per MIL-C-22992. Connectors for use with high mechanical and electrical stress.
<b>602 GB</b>	as per PAN 6432-1 and -4 as per MIL-C-83723, Series 1
<b>LJT</b>	as per MIL-C-38999, Series 1
<b>JT</b>	as per MIL-C 38999, Series 2
<b>SJT</b>	as per VG 96912; LN 29729; PAN 6433-2, JN 1003; EN 3372
<b>TRI-START</b>	as per MIL-C-38999, Series 3; JN 1034; EN 3645
<b>711/715</b>	as per MIL-STD 1553 B (DATA-BUS) as per PAN 6484/PAN 6486, JN 1032, JN 1033, JN 1056, JN 1057
<b>348</b>	as per MIL-C-81511 and VG 95329
<b>B<sup>3</sup></b>	Brush connector with up to 400 contacts for printed circuit boards
<b>DIN</b>	Connector for printed circuit boards as per DIN 41612 and VG 95324
–	Coaxial connectors as per MIL-C-39012
–	Connectors for fiber optic cables
–	Special designs following customer specifications
–	Filter connectors

◀ **Ordering information see overleaf**

PT 04/15  
Printed on chlorine-free bleached paper, subject to change.  
Copyright 03/02 by Amphenol-air LB GmbH, Germany

# Amphenol

Amphenol-Air LB GmbH

Am Kleinbahnhof 4 • D-66740 Saarlouis • Telephone +49 (0) 68 31 / 98 10 - 0 • Telefax +49 (0) 68 31 / 98 10 - 20 • <http://www.amphenol-airlb.de>

## X-ON Electronics

Largest Supplier of Electrical and Electronic Components

*Click to view similar products for [Circular MIL Spec Connector](#) category:*

*Click to view products by [Amphenol](#) manufacturer:*

Other Similar products are found below :

[0025-262-542](#) [0025-264-3014](#) [58-570121-04S](#) [0134-202-1200](#) [0134-207-1206](#) [0134-207-1800](#) [0134-207-2207](#) [0134-213-0806](#) [0134-213-1007](#) [0134-213-1009](#) [0134-213-1208](#) [0134-213-1800](#) [0134-213-2209](#) [0025-258-000](#) [015-9516-002](#) [60-042217-10P](#) [60-042722-19P](#) [0114-201-1278](#) [602GB06EG24-61SN](#) [0134-201-1207](#) [0134-201-1806](#) [0134-201-2006](#) [0134-201-2007](#) [0134-201-2010](#) [0134-202-1400](#) [0134-207-0809](#) [0134-207-1208](#) [0134-207-2009](#) [0134-213-1006](#) [6104-207-2302](#) [6104-208-1902](#) [6131-202-19149P](#) [6131-204-21149P](#) [6131-207-13149P](#) [6131-208-13149P](#) [6131-209-17149P](#) [6131-210-11149P](#) [6131-211-19149P](#) [6131-216-19149P](#) [6131-220-25149P](#) [6131-259-11149P](#) [6131-259-21149P](#) [6131-259-23149P](#) [6131-263-19149P](#) [6131-265-17149P](#) [6131-265-19149P](#) [6134-203-21149](#) [CS3102A-20-15P](#) [CS3102A-20-15S](#) [CS3102A-28-15S](#)