

AS3681

Power & Lighting Management Unit

Product Brief

1 General Description

The AS3681 is a highly-integrated, ultra-flexible CMOS Power- and Lighting Management Unit to supply power to LCD- and camera-modules in mobile telephones, and other 1-cell Li+ or 3-cell NIMH powered devices.

The AS3681 incorporates one low-power, low-dropout regulator (LDO), one Step Up DC/DC Converter for white backlight LEDs, one high-power Charge Pump for camera flash LEDs, one Analog-to-Digital Converter, support for up to 11 current sinks, a serial interface, and control logic all onto a single die.

The linear analog regulator features extremely high analog performance regarding:

- Noise (< 30 μ Vrms from 100Hz to 100kHz)
- Line/load Regulation (<1mV Static and <20mV Transient)
- Power Supply Rejection (>70dB@1kHz)
- Ultra-Low Power Consumption (1 μ A Shutdown, 6 μ A Standby)

LDO output voltages and output currents are programmable via a serial interface.

2 Key Features

- Programmable High-Performance Regulator
 - Low-Noise LDO (1.8 to 3.4V, 100mA)
 - 2.8V Default Output Voltage after Power-up
 - 3 μ A Quiescent Current in Standby (I_{out} <5mA)
 - Turns On/Off with Rising/Falling Edge of GPIO Supply Voltage
 - Programmable via Serial Interface
- High-Efficiency Step Up DC/DC Converter
 - Up to 25V/50mA for White LEDs
 - Programmable Output Voltage with External Resistors and Serial Interface
- High-Efficiency High-Power Charge Pump
 - 1:1, 1.5:1 and 2:1 Mode
 - Output Current up to 400mA
 - Efficiency up to 95%
 - Only 4 External Capacitors Required: 2 x 1 μ F Flying Capacitors, 2 x 2.2 μ F Input/Output Capacitors
 - Supports LCD White Backlight LEDs, Camera Flash White LEDs, and Keypad Backlight LEDs

- Supports up to 11 Current Sinks
 - Three Programmable (4-bit) from: 10 to 150mA resp. 300mA
 - Two Programmable (4-bit) from: 2.5 to 37.5 mA
 - Three Programmable (4-bit) from: 2.5 to 37.5 mA for RGB LEDs
 - Three Programmable (4-bit) from: 2.5 to 37.5mA for General Purpose Applications
 - Programmable Hardware Control (Strobe, PWM)
 - Selectively Enable/Disable Current Sinks
- 10-bit Successive Approximation ADC
 - 11 μ s Conversion Time
 - Two Selectable Inputs: GPIO0 and GPIO1
- Four General Purpose Inputs/Outputs
 - Digital Input, Digital Output, and Tristate
 - Programmable Pull-Up, and Pull-Down
 - GPIO2 can be used as Camera Flash Strobe
- Negative or High-Voltage Charge Pump
 - Regulated Output Voltage, Programmable by Dual Resistors e.g. -6V, 10mA for OLED or \pm 15V, 5mA for TFT
 - \pm 5% Accuracy
 - Requires Few External Components
- Standby LDO
 - Regulated 2.5V
 - Maximum Output Current 10mA
 - Always On (Supplies Internal Digital Blocks)
 - 3 μ A Quiescent Current
- Wide Battery Supply Range: 3.0 to 5.5V
- Serial Interface Control
- On-Chip Bandgap Tuning for High Accuracy (\pm 1%)
- Overcurrent and Thermal Protection
- 32-Pin, Small Form-Factor QFN Package (5 x 5 x 1mm, 0.5mm pitch), Enhanced Thermal Characteristics
- 1 Watt Power Dissipation @ T_{Ambient} = 70°C

3 Application

Power- and lighting-management for mobile telephones and other 1-cell Li+ or 3-cell NIMH powered devices.

Figure 2. Option (by software): General Purpose Current Sinks (Pins 23, 24, 28, 29) and External Charge Pump (Pins 25, 26, 27).

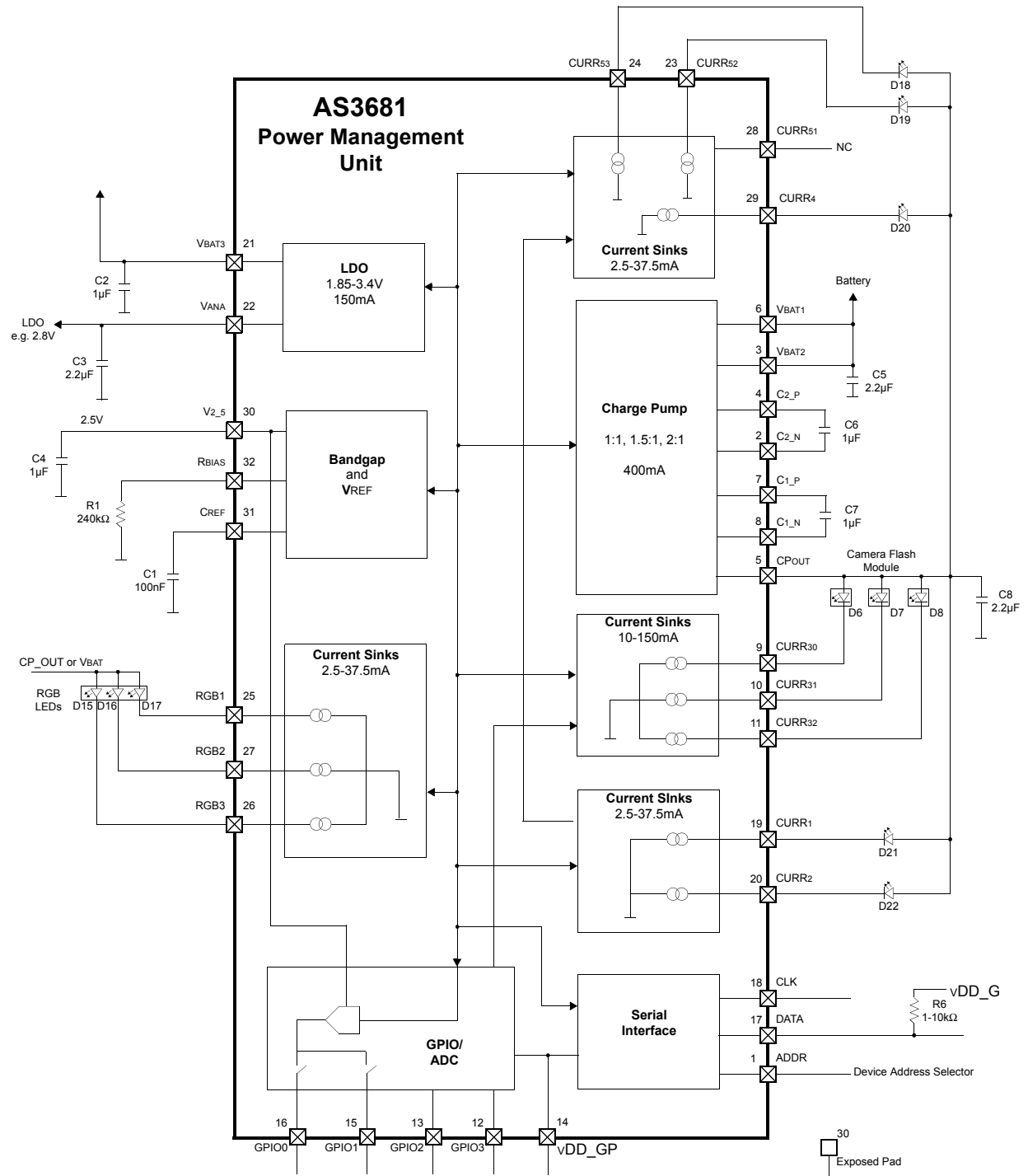

Copyrights

Copyright © 1997-2004, austriamicrosystems AG, Schloss Premstaetten, 8141 Unterpremstaetten, Austria-Europe. Trademarks Registered ®. All rights reserved. The material herein may not be reproduced, adapted, merged, translated, stored, or used without the prior written consent of the copyright owner.

All products and companies mentioned are trademarks or registered trademarks of their respective companies.

Disclaimer

Devices sold by austriamicrosystems AG are covered by the warranty and patent indemnification provisions appearing in its Term of Sale. austriamicrosystems AG makes no warranty, express, statutory, implied, or by description regarding the information set forth herein or regarding the freedom of the described devices from patent infringement. austriamicrosystems AG reserves the right to change specifications and prices at any time and without notice. Therefore, prior to designing this product into a system, it is necessary to check with austriamicrosystems AG for current information. This product is intended for use in normal commercial applications. Applications requiring extended temperature range, unusual environmental requirements, or high reliability applications, such as military, medical life-support or life-sustaining equipment are specifically not recommended without additional processing by austriamicrosystems AG for each application.

The information furnished here by austriamicrosystems AG is believed to be correct and accurate. However, austriamicrosystems AG shall not be liable to recipient or any third party for any damages, including but not limited to personal injury, property damage, loss of profits, loss of use, interruption of business or indirect, special, incidental or consequential damages, of any kind, in connection with or arising out of the furnishing, performance or use of the technical data herein. No obligation or liability to recipient or any third party shall arise or flow out of austriamicrosystems AG rendering of technical or other services.

Contact Information

Headquarters

austriamicrosystems AG
A-8141 Schloss Premstaetten, Austria

Tel: +43 (0) 3136 500 0

Fax: +43 (0) 3136 525 01

e-mail: info@austriamicrosystems.com

For Sales Offices, Distributors and Representatives, please visit:

<http://www.austriamicrosystems.com>

austriamicrosystems – a leap ahead in mixed signal

X-ON Electronics

Largest Supplier of Electrical and Electronic Components

Click to view similar products for [LED Lighting Development Tools](#) category:

Click to view products by [ams](#) manufacturer:

Other Similar products are found below :

[MIC2870YFT EV](#) [1278.1010](#) [ADP1660CB-EVALZ](#) [ADP8860DBCP-EVALZ](#) [AS1119-DB](#) [HV9919BDB1](#) [LM2796TLEV](#)
[LM3404MREVAL](#) [LP55231SQEVM](#) [ADM8843EB-EVALZ](#) [ADM8845EB-EVALZ](#) [ADP8861DBCBC-EVALZ](#) [TDGL014](#) [MIC2873YCS-EV](#)
[ISL97682IRTZEVALZ](#) [UCC25710EVM-654](#) [LM3508TLEV](#) [LM3549SQEV/NOPB](#) [LP3943ISQEV](#) [EA6358NH](#) [TPS61158EVM-565](#)
[TPS61187EVM-528](#) [TLC5929EVM-118](#) [ZLED7020Kit-D1 V2.0](#) [XRP7613EVB](#) [MAX16836EVKIT](#) [MAX16834EVKIT+](#)
[MAX16826EVKIT](#) [MAX16824EVKIT+](#) [MAX16823EVKIT+](#) [MAX16822BEVKIT+](#) [MAX16821BEVKIT+](#) [MAX16820EVKIT+](#)
[MAX16803EVKIT+](#) [NCL30081LEDGEVB](#) [STEVAL-ILL002V4](#) [MAX16833EVKIT+](#) [MAX16839EVKIT+](#) [TPS92315EVM-516](#)
[KIT12XS6EVM](#) [DC994A](#) [ISL78171EVAL1Z](#) [TLC59282EVM-118](#) [MAX6956EVKIT+](#) [TWR-MC36XSDEVB](#) [OM13321,598](#) [DC805A](#)
[DC381A](#) [ADM00942](#) [3106](#)