

# AS3911B

## NFC Initiator / HF Reader IC

### General Description

The AS3911B is a highly integrated NFC Initiator / HF Reader IC. It includes the analog front end (AFE) and a highly integrated data framing system for ISO 18092 (NFCIP-1) initiator, ISO 18092 (NFCIP-1) active target, ISO 14443 A and B reader (including high bit rates) and FeliCa™ reader. Implementation of other standard and custom protocols like MIFARE™ Classic<sup>1</sup> is possible through using the AFE and implementing framing in the external microcontroller (Stream and Transparent modes).

Compared with concurrent NFC devices designed with the mobile phone in mind, the AS3911B is positioned perfectly for the infrastructure side of the NFC system, where users need optimal RF performance and flexibility combined with low power.

With **ams'** unique Automatic Antenna Tuning technology, the device is optimized for applications with directly driven antennas. The AS3911B is alone in the domain of HF Reader ICs in that it contains two differential low impedance ( $1\Omega$ ) antenna drivers.

The AS3911B includes several features, which make it very well suited for low power applications. It contains a low power capacitive sensor, which can be used to detect the presence of a card without switching on the reader field. Additionally, the presence of a card can also be detected by performing a measurement of amplitude or phase of signal on antenna LC tank and comparing it to stored reference. It also contains a low power RC oscillator and wake-up timer, which can be used to wake the system after a defined time period and check for the presence of a tag using one or more techniques of low power detection of card presence (capacitive, phase or amplitude).

The AS3911B is designed to operate from a wide power supply range from 2.4 V to 5.5 V; peripheral interface IO pins support power supply range from 1.65 V to 5.5 V.

*Ordering Information and Content Guide appear at end of datasheet.*

---

1. MIFARE™ and MIFARE™ Classic are trademarks of NXP B.V.

## Key Benefits & Features

The benefits and features of AS3911B, NFC Initiator / HF Reader IC are listed below:

**Figure 1:**  
**Added Value of Using AS3911B**

Benefits	Features
<ul style="list-style-type: none"> <li>NFC Active P2P support</li> </ul>	<ul style="list-style-type: none"> <li>ISO 18092 (NFCIP-1) Active P2P</li> <li>ISO14443 A, B and FeliCa (TM)</li> </ul>
<ul style="list-style-type: none"> <li>High data transfer with ASK VHBR and fast SPI</li> </ul>	<ul style="list-style-type: none"> <li>Support of VHBR (3.4 Mbit/s PICC to PCD framing, 6.8 Mbit/s AFE and PCD to PICC framing)</li> </ul>
<ul style="list-style-type: none"> <li>6<math>\mu</math>A consumption at sensing every 100ms</li> </ul>	<ul style="list-style-type: none"> <li>Capacitive sensing - Wake-up</li> </ul>
<ul style="list-style-type: none"> <li>Antenna tuning on the fly</li> </ul>	<ul style="list-style-type: none"> <li>Automatic Antenna Tuning system providing tuning of antenna LC tank</li> </ul>
<ul style="list-style-type: none"> <li>Stable modulation index at ASK modulation</li> </ul>	<ul style="list-style-type: none"> <li>Automatic modulation index adjustment</li> </ul>
<ul style="list-style-type: none"> <li>No communication holes</li> </ul>	<ul style="list-style-type: none"> <li>AM and PM (I/Q) demodulator channels with automatic selection</li> </ul>
<ul style="list-style-type: none"> <li>High output power for EMVCo readers</li> </ul>	<ul style="list-style-type: none"> <li>Up to 1 W in case of differential output</li> </ul>
<ul style="list-style-type: none"> <li>High Rx sensitivity</li> </ul>	<ul style="list-style-type: none"> <li>User selectable and automatic gain control</li> </ul>
<ul style="list-style-type: none"> <li>Allows implementation of custom framings</li> </ul>	<ul style="list-style-type: none"> <li>Transparent and Stream modes to implement MIFARE™ Classic compliant or other custom protocols</li> </ul>
<ul style="list-style-type: none"> <li>Multi Antenna support</li> </ul>	<ul style="list-style-type: none"> <li>Possibility of driving two antennas in single ended mode</li> </ul>
<ul style="list-style-type: none"> <li>Smaller Oscillator size</li> </ul>	<ul style="list-style-type: none"> <li>Oscillator input capable of operating with 13.56 MHz or 27.12 MHz crystal with fast start-up</li> </ul>
<ul style="list-style-type: none"> <li>Easy FIFO handling</li> </ul>	<ul style="list-style-type: none"> <li>10 M bit SPI with 96 bytes FIFO</li> </ul>
<ul style="list-style-type: none"> <li>Battery powered operation</li> </ul>	<ul style="list-style-type: none"> <li>Wide supply voltage range from 2.4 V to 5.5 V</li> </ul>
<ul style="list-style-type: none"> <li>Fits Temperature requirements for various applications</li> </ul>	<ul style="list-style-type: none"> <li>Wide temperature range: -40°C to 125°C</li> </ul>
<ul style="list-style-type: none"> <li>Small outline, good cooling through exposed pad</li> </ul>	<ul style="list-style-type: none"> <li>QFN 5x5 LD32 package</li> </ul>

### Applications

The AS3911B is suitable for a wide range of applications including:

- EMV Payment
- Access Control
- NFC Infrastructure
- Ticketing

### Block Diagram

The functional blocks of this device for reference are shown below:

**Figure 2:**  
AS3911B Block Diagram

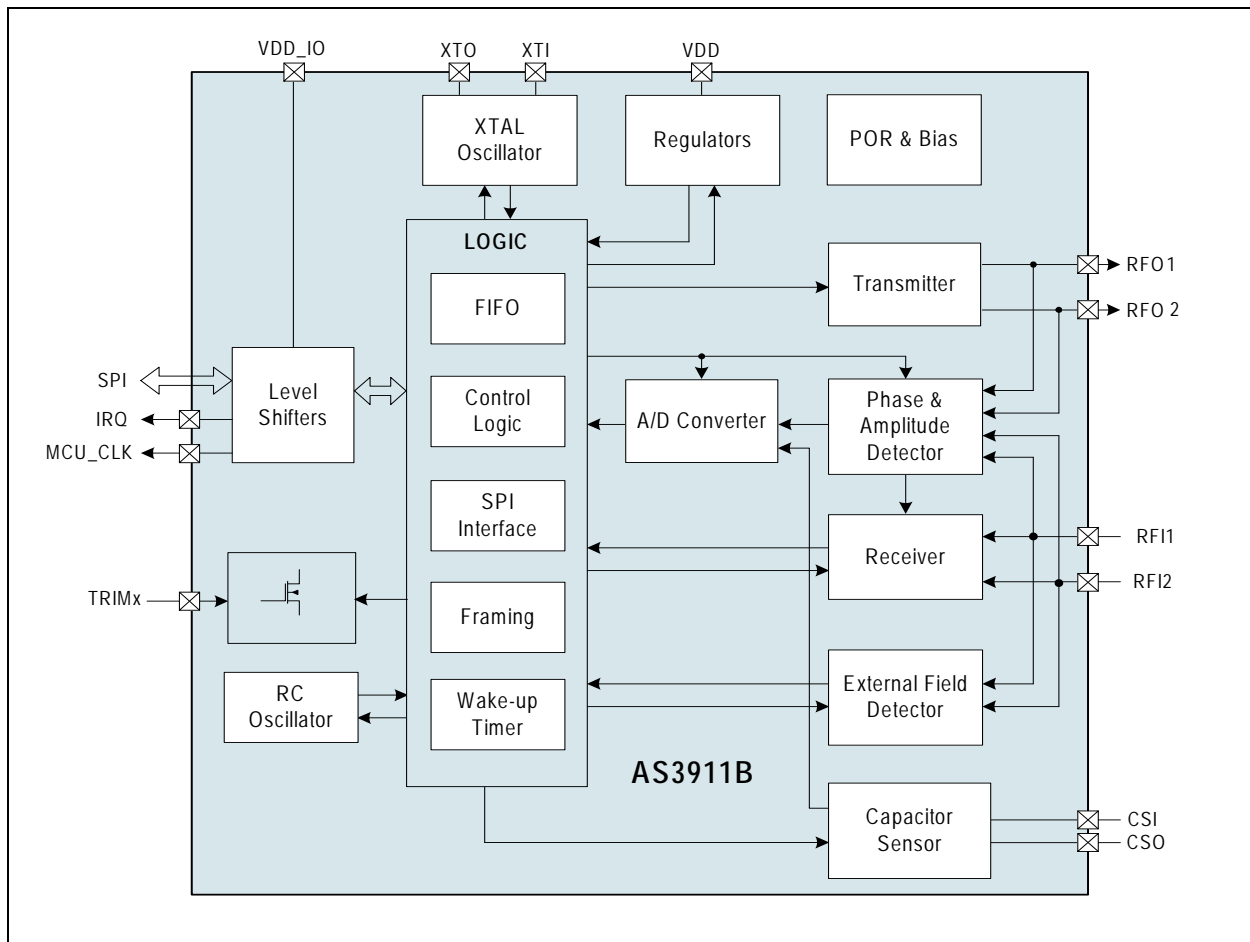

## Pin Assignment

The AS3911B pin and pad assignments are described below.

**AS3911B Pin Assignment:** This figure shows the pin assignment and location viewed from top.

**Figure 3:**  
QFN Pin Diagram

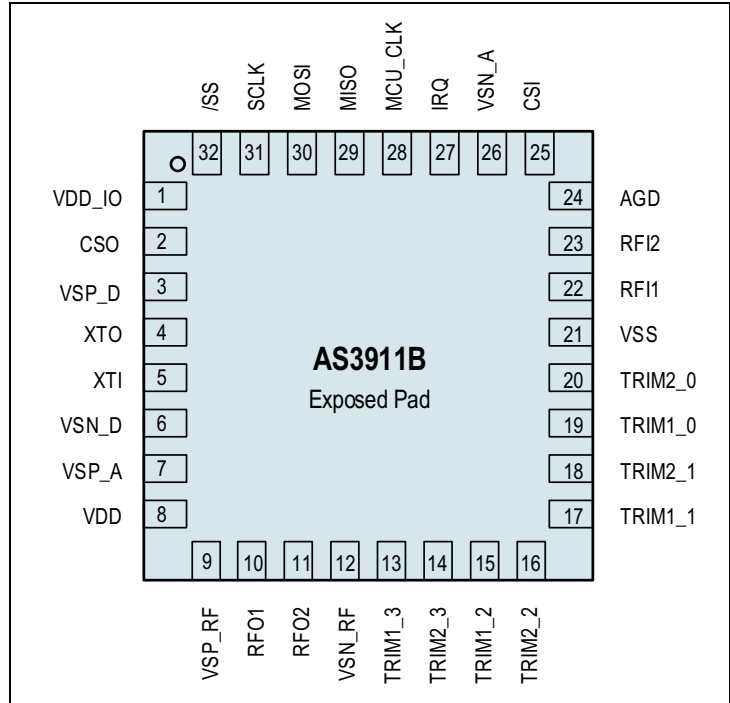

**Figure 4:**  
Die Pad Diagram

**AS3911B Pad Assignment:** This figure shows the pad assignment and location viewed from top.

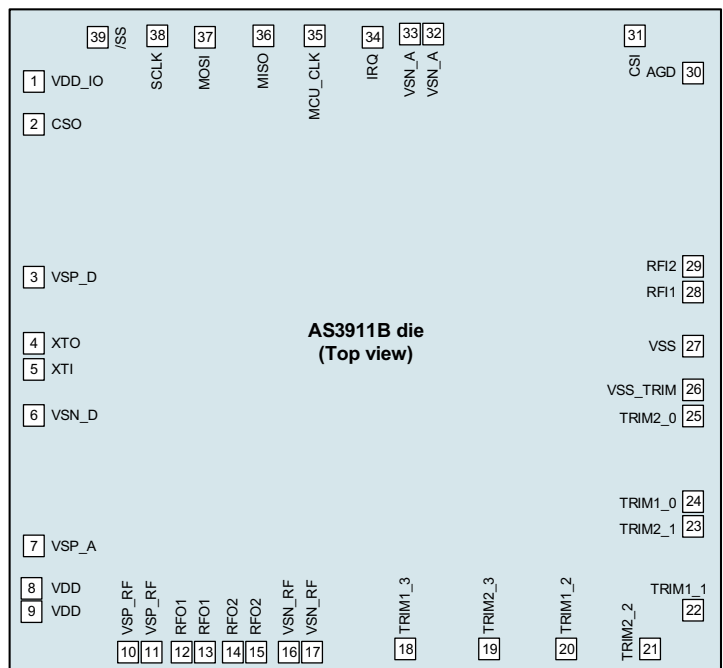

**Figure 5:**  
**Pin and Pad Description**

Pin Number		Pin Name	Pin Type	Description
QFN	Die			
1	1	V <sub>DD_IO</sub>	Supply pad	Positive supply for peripheral communication
2	2	CSO	Analog output	Capacitor sensor output
3	3	VSP_D		Digital supply regulator output
4	4	XTO		Xtal oscillator output
5	5	XTI	Analog input / Digital input	Xtal oscillator input
6	6	VSN_D	Supply pad	Digital ground
7	7	VSP_A	Analog output	Analog supply regulator output
8	8,9	V <sub>DD</sub>	Supply pad	External positive supply
9	10,11	VSP_RF	Analog output	Supply regulator output for antenna drivers
10	12,13	RFO1		Antenna driver output
11	14,15	RFO2		
12	16,17	VSN_RF	Supply pad	Ground of antenna drivers
13	18	TRIM1_3	Analog I/O	Input to trim antenna resonant circuit
14	19	TRIM2_3		
15	20	TRIM1_2		
16	21	TRIM2_2		
17	22	TRIM1_1		
18	23	TRIM2_1		
19	24	TRIM1_0		
20	25	TRIM2_0		
NA	26	V <sub>SS_TRIM</sub>	Supply pad	Ground, die substrate potential
21	27	V <sub>SS</sub>	Supply pad	Ground, die substrate potential
22	28	RFI1	Analog input	Receiver input
23	29	RFI2		
24	30	AGD	Analog I/O	Analog reference voltage
25	31	CSI	Analog input	Capacitor sensor input

Pin Number		Pin Name	Pin Type	Description
QFN	Die			
26	32, 33	VSN_A	Supply pad	Analog ground
27	34	IRQ	Digital output	Interrupt request output
28	35	MCU_CLK		Microcontroller clock output
29	36	MISO	Digital output / tristate	Serial Peripheral Interface data output
30	37	MOSI	Digital input	Serial Peripheral Interface data input
31	38	SCLK		Serial Peripheral Interface clock
32	39	/SS		Serial Peripheral Interface enable (active low)
#	NA	VSS	Exposed Pad	Ground, die substract potential, connect to VSS on PCB

## Absolute Maximum Ratings

Stresses beyond those listed under [Absolute Maximum Ratings](#) may cause permanent damage to the device. These are stress ratings only. Functional operation of the device at these or any other conditions beyond those indicated under [Operating Conditions](#) is not implied. Exposure to absolute maximum rating conditions for extended periods may affect device reliability.

**Figure 6:**  
Absolute Maximum Ratings

Symbol	Parameter	Min	Max	Unit	Comments
<b>Electrical Parameters</b>					
$V_{DD}$	DC supply voltage	-0.5	6.0	V	
$V_{DD\_IO}$	DC_IO supply voltage	-0.5	6.0	V	
$V_{INTRIM}$	Input pin voltage TRIM pins	-0.5	25.0	V	
$V_{IN}$	Input pin voltage for peripheral communication pins	-0.5	6.5	V	
$V_{INA}$	Input pin voltage for analog pins	-0.5	6.0	V	
$I_{scr}$	Input current (latch-up immunity)	-100	100	mA	Norm: JEDEC 78
$I_{outmax}$	Drive capability of output driver	0	600	mA	
<b>Electrostatic Discharge</b>					
ESD	Electrostatic discharge	$\pm 2$		kV	Standard MIL-STD-883-J-3015.9 (Human Body Model)
		$\pm 500$		V	Valid for Trimx.x pins (pins 13 - 20)
<b>Temperature Ranges and Storage Conditions</b>					
$T_{strg}$	Storage temperature	-55	125	°C	
$T_{body}$	Package body temperature		260	°C	Norm: IPC/JEDEC J-STD-020. <i>The reflow peak soldering temperature (body temperature) is specified according IPC/JEDEC J-STD-020 "Moisture/Reflow Sensitivity Classification for Non-hermetic Solid State Surface Mount Devices."</i> The lead finish for Pb-free leaded packages is matte tin (100% Sn).
$RH_{NC}$	Relative Humidity non-condensing	5	85	%	
MSL	Moisture Sensitivity Level	3			Represents a max. floor life time of 168h

## Electrical Characteristics

All limits are guaranteed. The parameters with min and max values are guaranteed with production tests or SQC (Statistical Quality Control) methods.

### Operating Conditions

All defined tolerances for external components in this specification need to be assured over the whole operation condition range and also over lifetime.

**Figure 7:**  
Operating Conditions

Symbol	Parameter	Min	Max	Unit	Comments
$V_{DD}$	Positive supply voltage	2.4	5.5	V	In case power supply is lower than 2.6 V, PSSR cannot be improved using internal regulators (minimum regulated voltage is 2.4 V)
$V_{DD\_IO}$	Peripheral communication supply voltage	1.65	5.5	V	
$V_{SS}$	Negative supply voltage	0	0	V	
$V_{INTRIM}$	Input pin voltage TRIM pins		20	V	
$T_{JUN}$	Junction temperature	-40	125	°C	
$V_{RFI\_A}$	RFI input amplitude	150 m	3	$V_{pp}$	Minimum RFI input signal definition is meant for NFC receive mode. In HF reader mode and NFC transmit mode, the recommended signal level is 2.5 $V_{pp}$
RFO	Driver current	0	500	mA	

## DC/AC Characteristics for Digital Inputs and Outputs

### CMOS Inputs:

Valid for input pins /SS, MOSI, and SCLK

**Figure 8:**  
CMOS Inputs

Symbol	Parameter	Min	Max	Unit
$V_{IH}$	High level input voltage	$0.7 * V_{DD\_IO}$	$V_{DD\_IO}$	V
$V_{IL}$	Low level input voltage	VSS	$0.3 * V_{DD\_IO}$	V
$I_{LEAK}$	Input leakage current	-1	1	$\mu A$



**CMOS Outputs:**

Valid for output pins MISO, IRQ and MCU\_CLK,  $io\_18=0$  (IO Configuration Register 2).

**Figure 9:**  
CMOS Outputs

Symbol	Parameter	Conditions	Min	Typ	Max	Unit
$V_{OH}$	High level output voltage	$I_{SOURCE/SINK} = 1\text{mA}$ measured at $V_{DDIO} = 2.4\text{V}$	$0.9 * V_{DD\_IO}$		$V_{DD\_IO}$	V
$V_{OL}$	Low level output voltage	$I_{SOURCE/SINK} = 0.5\text{mA}$ measured at $V_{DDIO} = 1.65\text{V}$	0		$0.1 * V_{DD\_IO}$	V
$C_L$	Capacitive load		0		50	pF
$R_O$	Output Resistance		0	250	550	$\Omega$
$R_{PD}$	Pull-down resistance pin MISO	Pull-down can be enabled while MISO output is in tristate. The activation is controlled by register setting.	5	10	15	k $\Omega$

**Electrical Specification**

$V_{DD} = 3.3\text{V}$ , Temperature  $25^\circ\text{C}$  unless noted otherwise.

3.3V supply mode, regulated voltages set to 3.4 V, 27.12 MHz Xtal connected to XTO and XTI.

**Figure 10:**  
Electrical Specification

Symbol	Parameter	Min	Typ	Max	Unit	Comments
$I_{PD}$	Supply current in Power-down mode	0.2	0.7	2	$\mu\text{A}$	Register 00 <sub>h</sub> set to 0F <sub>h</sub> (no clock on MCU_CLK), register 01 <sub>h</sub> set to 80 <sub>h</sub> (3V supply mode), register 02 <sub>h</sub> set to 00 <sub>h</sub> register 03 <sub>h</sub> set to 08 <sub>h</sub> , other registers in default state.
$I_{NFCT}$	Supply current in initial NFC Target mode	2.2	3.5	7	$\mu\text{A}$	Register 00 <sub>h</sub> set to 0F <sub>h</sub> (no clock on MCU_CLK), register 01 <sub>h</sub> set to 80 <sub>h</sub> (3V supply mode), register 02 <sub>h</sub> set to 00 <sub>h</sub> register 03 <sub>h</sub> set to 80 <sub>h</sub> (enable NFC Target mode), other registers in default state.

Symbol	Parameter	Min	Typ	Max	Unit	Comments
$I_{WU}$	Supply current in Wake-up mode	1.6	3.6	8	$\mu\text{A}$	Register 00 <sub>h</sub> set to 0F <sub>h</sub> (no clock on MCU_CLK), register 01 <sub>h</sub> set to 80 <sub>h</sub> (3V supply mode), register 02 <sub>h</sub> set to 04 <sub>h</sub> (enable Wake-up mode), register 03 <sub>h</sub> set to 08 <sub>h</sub> , register 31 <sub>h</sub> set to 08 <sub>h</sub> (100ms timeout, IRQ at every timeout), other registers in default state.
$I_{CS}$	Capacitive sensor supply current	0.6	1.1	2	mA	Register 00 <sub>h</sub> set to 0F <sub>h</sub> (no clock on MCU_CLK), register 01 <sub>h</sub> set to 80 <sub>h</sub> (3 V supply mode), register 02 <sub>h</sub> set to 00 <sub>h</sub> , analog test mode 14, other registers in default state.
$I_{RD}$	Supply current in Ready mode	4	5.4	7.5	mA	Register 00 <sub>h</sub> set to 0F <sub>h</sub> (no clock on MCU_CLK), register 01 <sub>h</sub> set to C0 <sub>h</sub> (3 V supply mode, disable VSP_D), register 02 <sub>h</sub> set to 80 <sub>h</sub> , register 03 <sub>h</sub> set to 08 <sub>h</sub> , other registers in default state, short VSP_A and VSP_D.
$I_{AL}$	Supply current all active	6.2	8.7	12.5	mA	Register 00 <sub>h</sub> set to 0F <sub>h</sub> , register 01 <sub>h</sub> set to C0 <sub>h</sub> (3V supply mode, disable VSP_D), register 02 <sub>h</sub> set to E8 <sub>h</sub> (one channel Rx, enable Tx), register 03 <sub>h</sub> set to 08, register 0B <sub>h</sub> set to 00, register 27 <sub>h</sub> set to FF (all RFO segments disabled), other registers in default state, short VSP_A and VSP_D.
$I_{LP}$	Supply current all active, low power receiver mode	4.8	6.8	10	mA	Register 00 <sub>h</sub> set to 0F <sub>h</sub> , register 01 <sub>h</sub> set to C0 <sub>h</sub> (3V supply mode, disable VSP_D), register 02 <sub>h</sub> set to E8 <sub>h</sub> (one channel Rx, enable Tx), register 03 <sub>h</sub> set to 08, register 0B <sub>h</sub> set to 80 (low power mode), register 27 <sub>h</sub> set to FF (all RFO segments disabled), other registers in default state, short VSP_A and VSP_D.

Symbol	Parameter	Min	Typ	Max	Unit	Comments
$R_{RFO}$	RFO1 and RFO2 driver output resistance	0.25	0.6	1.8	$\Omega$	$I_{RFO} = 10 \text{ mA}$ The following measurement procedure which cancels resistance of measurement setup is used: <ul style="list-style-type: none"> <li>All driver segments are switched on, resistance is measured,</li> <li>All driver segments except the MSB segment are switched on, resistance is measured,</li> <li>Difference between the two measurements is resistance of MSB segment,</li> <li>Resistance of MSB segment multiplied by two is the value of <math>R_{RFO}</math>.</li> </ul>
$Z_{load}$	Load impedance across RFO1 & RFO2	8	10	50	$\Omega$	Using Load impedance lower than minimum value can result in permanent damage of the IC
$V_{RFI}$	RFI input sensitivity		0.5		$\text{mV}_{\text{rms}}$	$f_{\text{SUB}}=848 \text{ kHz}$ , AM channel with peak detector input stage selected.
$R_{RFI}$	RFI input resistance	5	10	15	$\text{k}\Omega$	
$V_{POR}$	Power on Reset Voltage	1.31	1.5	1.75	V	
$V_{AGD}$	AGD voltage	1.4	1.5	1.6	V	Register 00 <sub>h</sub> set to 0F <sub>h</sub> (no clock on MCU_CLK), register 01 <sub>h</sub> set to C0 <sub>h</sub> (3 V supply mode, disable VSP_D), register 02 <sub>h</sub> set to 80 <sub>h</sub> , register 03 <sub>h</sub> set to 08 <sub>h</sub> , other registers in default state, short VSP_A and VSP_D.
$V_{REG}$	Regulated voltage	2.80	3.0	3.32	V	Manual regulator mode, regulated voltage set to 3.0 V, measured on pin VSP_RF: register 00 <sub>h</sub> set to 0F <sub>h</sub> , register 01 <sub>h</sub> set to 80 <sub>h</sub> (3V supply mode), register 02 <sub>h</sub> set to E8 <sub>h</sub> (one channel Rx, enable Tx), register 2A <sub>h</sub> set to D8 <sub>h</sub> .
$T_{OSC}$	Oscillator start-up time	0.65	0.7	10	ms	13.56MHz or 27.12MHz crystal $ESR_{\text{MAX}} = 150 \Omega$ max, load capacitance according to crystal specification, IRQ is issued once the oscillator frequency is stable. This parameter changes with ESRMAX parameter.

Typical Operating Characteristics

Thermal Resistance and Max. Power Dissipation

Figure 11: TCASE vs. Power with Different Copper Area @  $T_{AMB} = 25^{\circ}C$

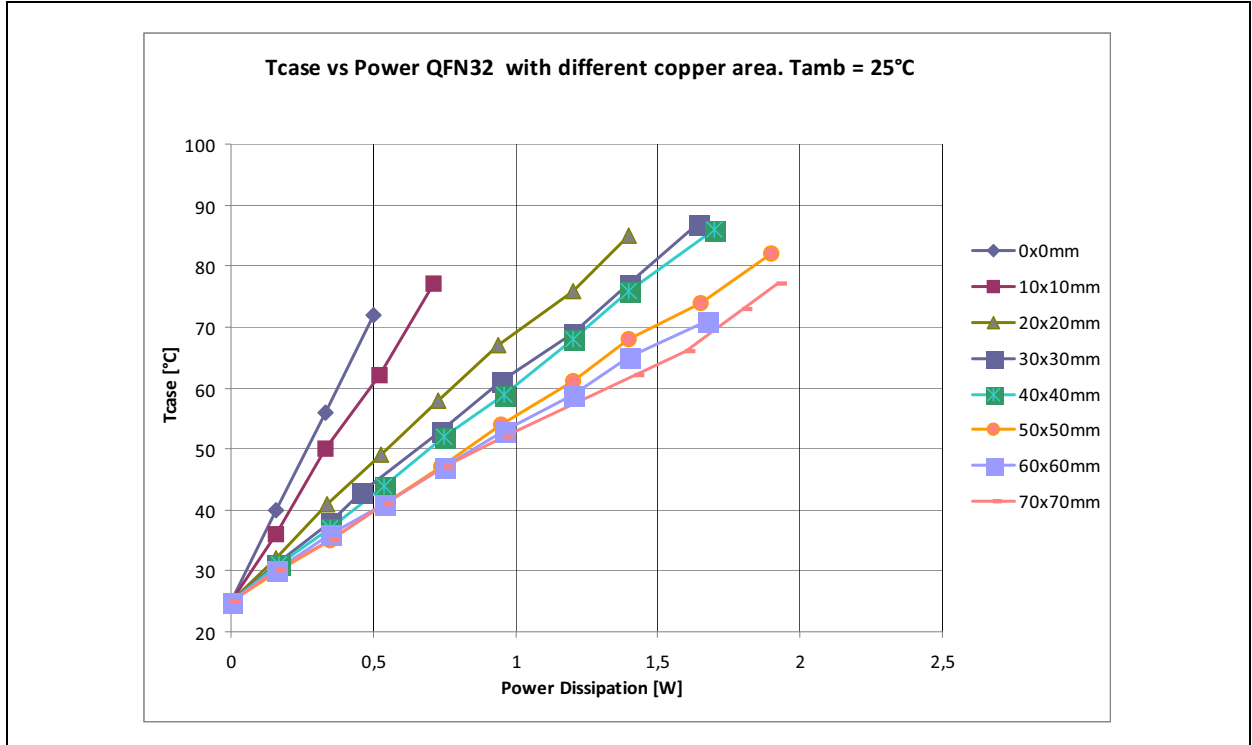
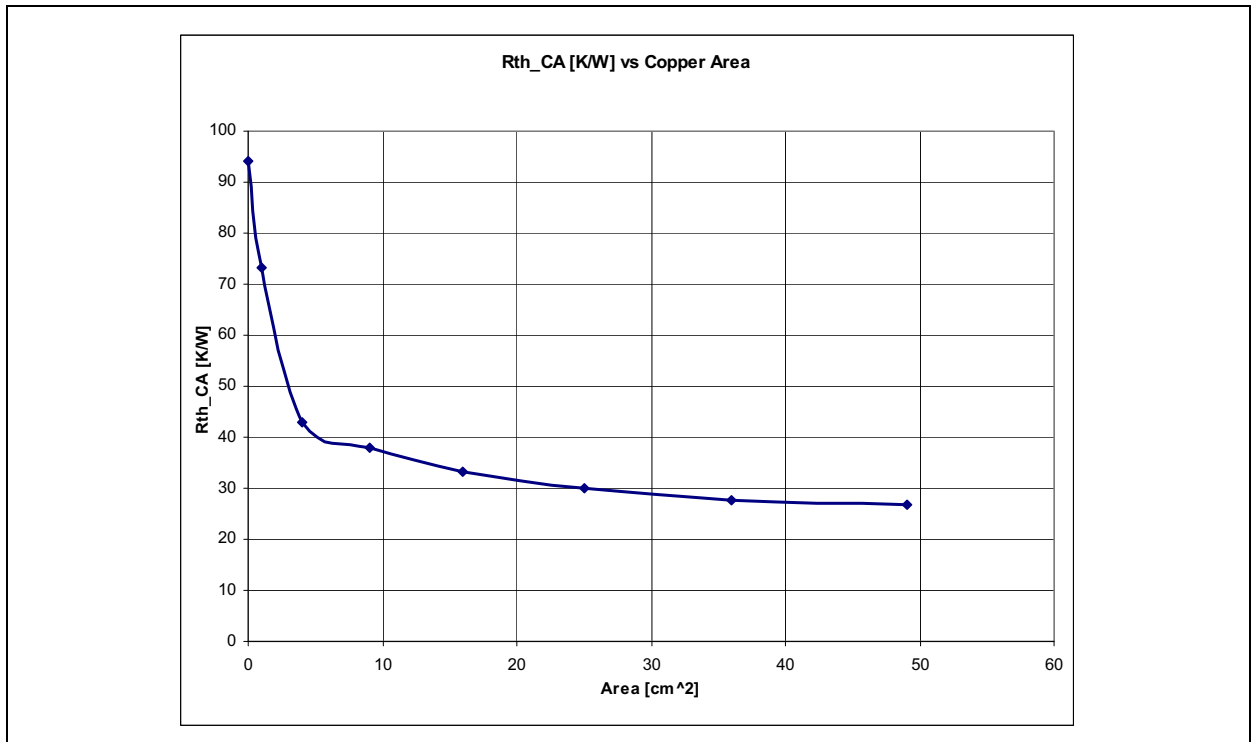
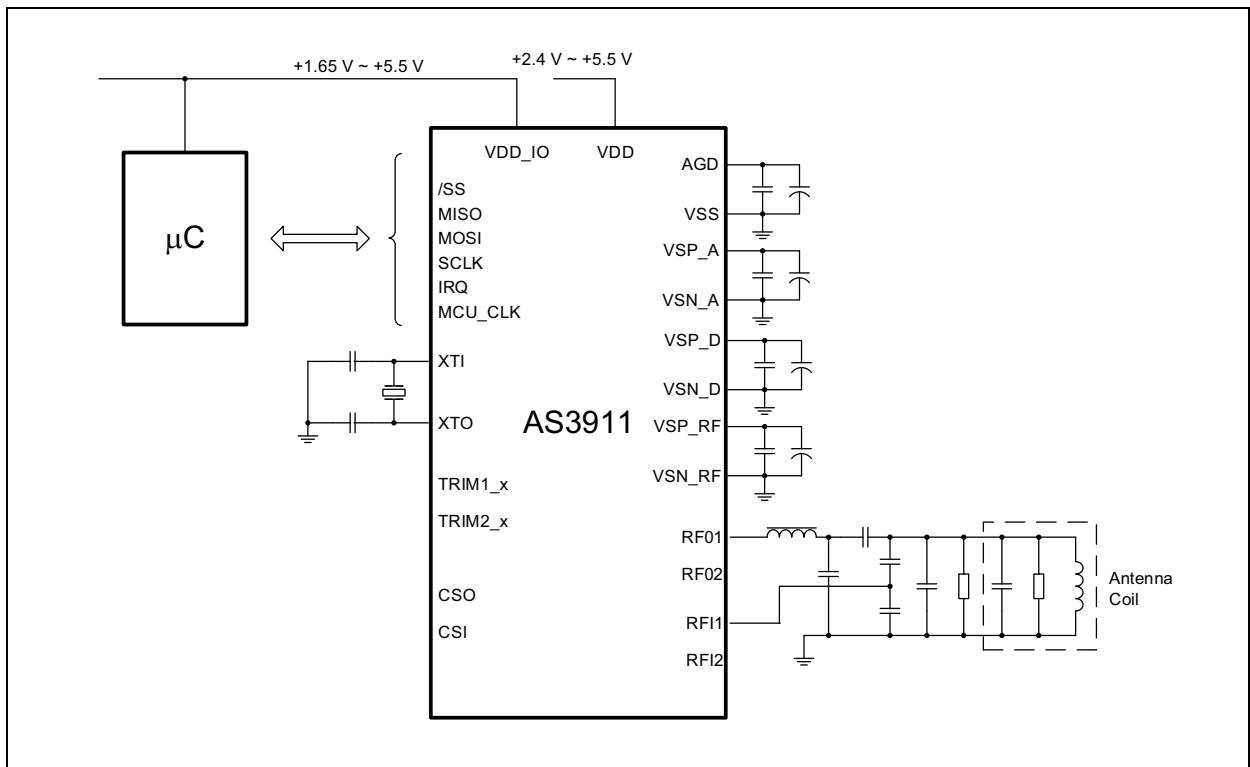

Figure 12: RthCA vs. Copper Area



## Detailed Description

**Figure 13:**  
Minimum Configuration with Single Sided Antenna Driving Including EMC Filter



**Figure 14:**  
Minimum Configuration with Differential Antenna Driving Including EMC Filter

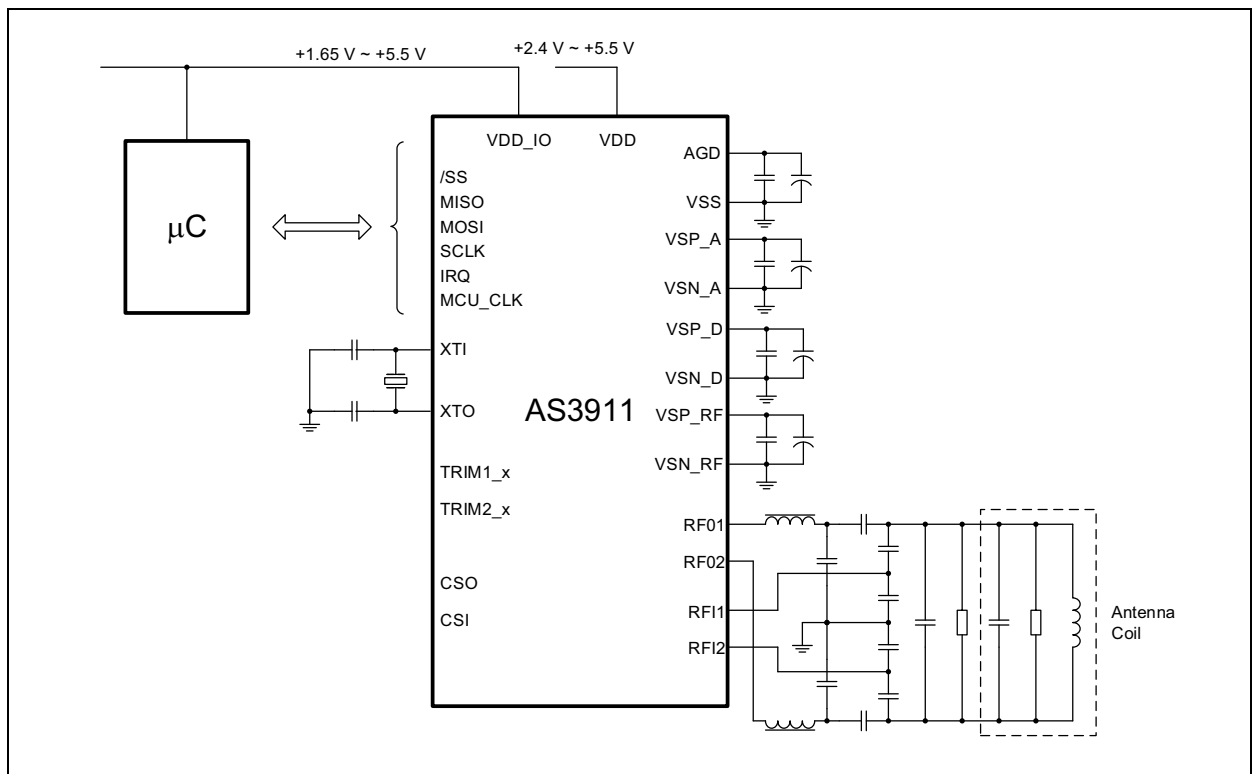

## Transmitter

The transmitter incorporates drivers which drive external antenna through pins RFO1 and RFO2. Single sided and differential driving is possible. The transmitter block additionally contains a sub-block which modulates transmitted signal (OOK or configurable AM modulation).

The AS3911B transmitter is intended to directly drive antennas (without 50  $\Omega$  cable, usually antenna is on the same PCB). Operation with 50  $\Omega$  cable is also possible, but in that case some of the advanced features are not possible.

By applying FFh to the register 27h, the output driver are in tristate.

## Receiver

The receiver detects transponder modulation superimposed on the 13.56MHz carrier signal. The receiver contains two receive chains (one for AM and another for PM demodulation) which are composed of a peak detector followed by two gain and filtering stages and a final digitizer stage. The filter characteristics are adjusted to optimize performance over different ISO modes and bit rates (sub-carrier frequencies from 212 kHz to 6.8 MHz are supported). The receiver chain inputs are RF11 and RF12 pins; output of digitizer stage is demodulated sub-carrier signal. The receiver chain incorporates several features which enable reliable operation in challenging phase and noise conditions.

## Phase and Amplitude Detector

The phase detector is observing the phase difference between the transmitter output signals (RFO1 and RFO2) and the input signals RF11 and RF12. Signals RF11 and RF12 are proportional to the signal on the antenna LC tank. RF11 and RF12 signals are also used to run the self-mixer which generates output proportional to their amplitude. The phase detector and self-mixer blocks are used for several purposes:

- PM demodulation by observing RF11 and RF12 phase variation (LF signal is fed to the Receiver)
- Average phase difference between RFOx pins and RF1x pins is used to check antenna tuning
- Output of mixer is used to measure amplitude of signal present on pins RF11 and RF12

## A/D Converter

The AS3911B contains a built in A/D Converter. Its input can be multiplexed from different sources and is used in several applications (measurement of RF amplitude and phase, calibration of modulation depth...). The result of A/D conversion is stored in a register which can be read through the SPI interface.

## Capacitive Sensor

The Capacitive sensor is used to implement low power detection of transponder presence. Capacitive sensor performs measurement of capacitance between its two electrodes. Presence of an object (card, hand) changes the capacitance. During calibration the reference capacitance, which represents parasitic capacitance of environment is stored. In normal operation capacitance is periodically measured and compared to stored reference value. When the measured capacitance is larger than stored reference value (threshold value can be defined in a register) an interrupt is sent to external controller.

## External Field Detector

The External Field Detector is a low power block which is used in NFC mode to detect presence of external RF field. It supports two different detection thresholds, Peer Detection Threshold and Collision Avoidance Threshold. Peer Detection Threshold is used in the NFCIP-1 target mode to detect presence of initiator field. It is also used in active communication initiator mode to detect activation of target field. Collision Avoidance Threshold is used to detect a presence of RF field during NFCIP-1 RF Collision Avoidance procedure.

## Quartz Crystal Oscillator

The quartz crystal oscillator can operate with 13.56 MHz and 27.12 MHz crystals. At start-up the transconductance of the oscillator is increased to achieve fast start-up. Since the start-up time varies depending on crystal type, temperature and other parameters, the oscillator amplitude is observed and an interrupt is sent when stable operation is reached to inform the controller that the clock signal is stable and reader field can be switched on. The use of 27.12 MHz crystal is mandatory in case VHBR framing is used.

It also provides a clock signal to the external microcontroller (MCU\_CLK) according to setting in the control register.

## Power Supply Regulators

Integrated power supply regulators ensure high power supply rejection of a complete reader system. In case PSRR of the reader system has to be improved, the command [Adjust Regulators](#) is sent. As result of this command, the power supply level of  $V_{DD}$  is measured in maximum load conditions and the regulated voltage reference is set 250 mV below this measured level to assure a stable regulated supply. The resulting regulated voltage is stored in a register. It is also possible to define regulated voltage by writing a configuration register. In order to decouple any noise sources from different parts of IC there are three regulators integrated with separated external blocking capacitors (regulated voltage of all is the same in 3.3 V supply mode). One regulator is for the analog blocks, one for

digital blocks, there is also a separate one for the antenna drivers. In case of low cost applications some (or all) regulators may not be used to save on external components.

This block additionally generates a reference voltage for the analog processing (AGD - analog ground). This voltage also has an associated external buffer capacitor.

### **POR and Bias**

This block contains the bias current and voltage generator which provides bias currents and reference voltages to all other blocks. It also incorporates a Power on Reset (POR) circuit which provides a reset at power-up and at low supply levels.

### **RC Oscillator and Wake-up Timer**

The AS3911B includes several possibilities of low power detection of a card presence (capacitive sensor, phase measurement, amplitude measurement). RC oscillator and register configurable Wake-up timer are used to schedule periodic detection. When presence of a card is detected an interrupt is sent to controller.

### **ISO14443 and NFCIP-1 Framing**

This block performs framing for receive and transmit according to the selected ISO mode and bit rate settings.

In reception it takes demodulated sub-carrier signal from Receiver. It recognizes the SOF, EOF and data bits, performs parity and CRC check, organizes the received data in bytes and places them in the FIFO.

During transmit, it operates inversely, it takes bytes from FIFO, generates parity and CRC bits, adds SOF and EOF and performs final encoding before passing modulation signal to transmitter.

In Transparent mode, the framing and FIFO are bypassed, the digitized sub-carrier signal, which is Receiver output, is directly sent to MISO pin, signal applied to MOSI pin is directly used to modulate the transmitter.

### **FIFO**

The AS3911B contains a 96 byte FIFO. Depending on the mode, it contains either data which has been received or data which is to be transmitted.

### **Control Logic**

The control logic contains I/O registers which define operation of device.

### **SPI Interface**

A 4-wire Serial Peripheral Interface (SPI) is used for communication between external microcontroller and the AS3911B.



## Application Information

### Operating Modes

The AS3911B operating mode is defined by the contents of the [Operation Control Register](#).

At power-up all bits of the [Operation Control Register](#) are set to 0, the AS3911B is in **Power-down** mode. In this mode AFE static power consumption is minimized, only the POR and part of the bias are active, the regulators are transparent and are not operating. The SPI is still functional in this mode so all settings of ISO mode definition and configuration registers can be done.

Control bit *en* (bit 7 of the [Operation Control Register](#)) is controlling the quartz crystal oscillator and regulators. When this bit is set, the device enters in **Ready** mode. In this mode the quartz crystal oscillator and regulators are enabled. An interrupt is sent to inform the microcontroller when the oscillator frequency is stable.

Enable of Receiver and Transmitter are separated so it is possible to operate one without switching on the other (control bits *rx\_en* and *tx\_en*). In some cases this may be useful, in case the reader field has to be maintained and there is no transponder response expected receiver can be switched-off to save current. Another example is NFCIP-1 active communication receive mode in which RF field is generated by the initiator and only Receiver operates.

Asserting the [Operation Control Register](#) bit *wu* while the other bits are set to 0 puts the AS3911B into the **Wake-up** mode which is used to perform low power detection of card presence. In this mode the low power RC oscillator and register configurable Wake-up timer are used to schedule periodic measurement(s). When a difference to the predefined reference is detected an interrupt is sent to wake-up the micro. Capacitive sensor, phase measurement and amplitude measurement are available.

### Transmitter

The Transmitter contains two identical push-pull driver blocks connected to the pins RFO1 and RFO2. These drivers are differentially driving external antenna LC tank. It is also possible to operate only one of the two drivers by setting the [IO Configuration Register 1](#) bit *single*. Each driver is composed of 8 segments having binary weighted output resistance. The MSB segment typical ON resistance is 2  $\Omega$ , when all segments are turned on; the output resistance is typically 1  $\Omega$ . Usually all segments are turned on to define the normal transmission (non-modulated) level. It is also possible to switch off certain segments when driving the non-modulated level to reduce the amplitude of signal on the antenna and/or to reduce the antenna Q factor without making any hardware changes. The [RFO Normal Level Definition Register](#) defines which segments

are turned on to define the normal transmission (non-modulated) level. Default setting is that all segments are turned on.

Using the single driver mode the number and therefore the cost of the antenna LC tank components is halved, but also the output power is reduced. In single mode it is possible to connect two antenna LC tanks to the two RFO outputs and multiplex between them by controlling the [IO Configuration Register 1](#) bit *rfo2*.

In order to transmit the data the transmitter output level needs to be modulated. The AM and OOK modulation are supported. The type of modulation is defined by setting the bit *tr\_am* in the [Auxiliary Definition Register](#). For the operation modes supported by the AS3911B framing the setting of modulation type is done automatically by sending direct command [Analog Preset](#).

During the OOK modulation (for example ISO14443A) the Transmitter drivers stop driving the carrier frequency; drivers are frozen in state before the modulation. As consequence the amplitude of the antenna LC tank oscillation decays, the time constant of the decay is defined with the LC tank Q factor. The decay time in case of OOK modulation can be shortened by asserting the [Auxiliary Definition Register](#) bit *ook\_hr*. When this bit is set to logic one the drivers are put in tristate during the OOK modulation.

AM modulation (for example ISO14443B) is done by increasing the output driver impedance during the modulation time. This is done by reducing the number of driver segments which are turned on. The AM modulated level can be automatically adjusted to the target modulation depth by defining the target modulation depth in the [AM Modulation Depth Control Register](#) and sending the [Calibrate Modulation Depth](#) direct command. Please refer to [AM Modulation Depth: Definition and Calibration](#) for further details.

### **Slow Transmitter Ramping**

When transmitter is enabled it starts to drive the antenna LC tank with full power, the ramping of field emitted by antenna is defined by antenna LC tank Q factor.

However there are some reader systems where the reader field has to transition with a longer transition time when it is enabled. The STIF (Syndicat des transports d'Ile de France) specification requires a transition time from 10% to 90% of field longer than or equal to 10  $\mu$ s.

The AS3911B supports that feature. It is realized by collapsing VSP\_RF regulated voltage when transmitter is disabled and ramping it when transmitter is enabled. Typical transition time is 15  $\mu$ s at 3 V supply and 20  $\mu$ s at 5 V supply.

Procedure to implement the slow transition:

- When transmitter is disabled set [IO Configuration Register 2](#) bit *slow\_up* to 1. Keep this state at least 2 ms to allow discharge of VSP\_RF.
- Enable transmitter, its output will ramp slowly.
- Before sending any command set the bit *slow\_up* back to 0.

### **Receiver**

The receiver performs demodulation of the transponder sub-carrier modulation which is superimposed on the 13.56MHz carrier frequency. It performs AM and/or PM demodulation, amplification, band-pass filtering and digitalization of sub-carrier signals. Additionally it performs RSSI measurement, automatic gain control (AGC) and Squelch function.

In typical application the Receiver inputs RF1 and RF2 are outputs of capacitor dividers connected directly to the terminals of antenna coil. Such concept assures that the two input signals are in phase to the voltage on antenna coil. Care has to be taken during design of capacitive divider that the RF1 and RF2 input signal pp value does not exceed the VSP\_A supply voltage.

Receiver comprises two complete receive channels for AM demodulation and PM demodulation. In case both channels are active the selection of channel used for reception framing is done automatically by receive framing logic. The receiver is switched on when [Operation Control Register](#) bit *rx\_en* is set to one. Additionally the [Operation Control Register](#) contains bits *rx\_chn* and *rx\_man*; *rx\_chn* defines whether both, AM and PM, demodulation channels will be active or only one of them, while bit *rx\_man* defines the channel selection mode in case both channels are active (automatic or manual). Operation of the Receiver is controlled by four Receiver Configuration registers.

The operation of the receiver is additionally controlled by the signal *rx\_on* which is set high when modulated signal is expected on the receiver input. This signal is used to control

RSSI and AGC and also enables processing of receiver output by Framing logic. Signal *rx\_on* is automatically set high after Mask Receive timer expires. Signal *rx\_on* can also be directly controlled by the controller by sending direct commands [Mask Receive Data](#) and [Unmask Receive Data](#). [Figure 15](#) illustrates the Receiver block diagram.

### **Demodulation Stage**

First stage performs demodulation of transponder sub-carrier response signal, which is superimposed on HF field carrier. Two different blocks are implemented for AM demodulation: Peak Detector and AM demodulator mixer. The choice of the demodulator, which is used, is made by the [Receiver Configuration Register 1](#) bit *amd\_sel*.

Peak detector performs AM demodulation using peak follower. Both, the positive and negative peaks are tracked to suppress common mode signal. It is limited in speed; it can operate for sub-carrier frequencies up to  $f_c/8$  (1700 kHz). It has demodulation gain  $G = 0.7$ . Its input is taken from one demodulator input only (usually RF11).

AM demodulator mixer uses synchronous rectification of both receiver inputs (RF11 and RF12). Its gain is  $G = 0.55$ . Mixer demodulator is optimized for VHBR sub-carrier frequencies ( $f_c/8$  and higher). For sub-carrier frequency  $f_c/8$  (1700 kHz) both peak follower and mixer can be used, while for  $f_c/4$  and  $f_c/2$  are supported only by mixer.

By default the Peak detector is used, for data rates  $f_c/8$  and higher use of mixer is automatically preset by sending direct command [Analog Preset](#).

PM demodulation is also done by a mixer. The PM demodulator mixer has differential outputs with 60mV differential signal for 1% phase change (16.67 mV per degree). Its operation is optimized for sub-carrier frequencies up to  $f_c/8$  (1700 kHz).

In case the demodulation is done externally of the AS3911B it is possible to multiplex the LF signals applied to pins RF11 and RF12 directly to the gain and filtering stage by selecting the [Receiver Configuration Register 2](#) bit *lf\_en*.

**Figure 15:**  
**Receiver Block Diagram**

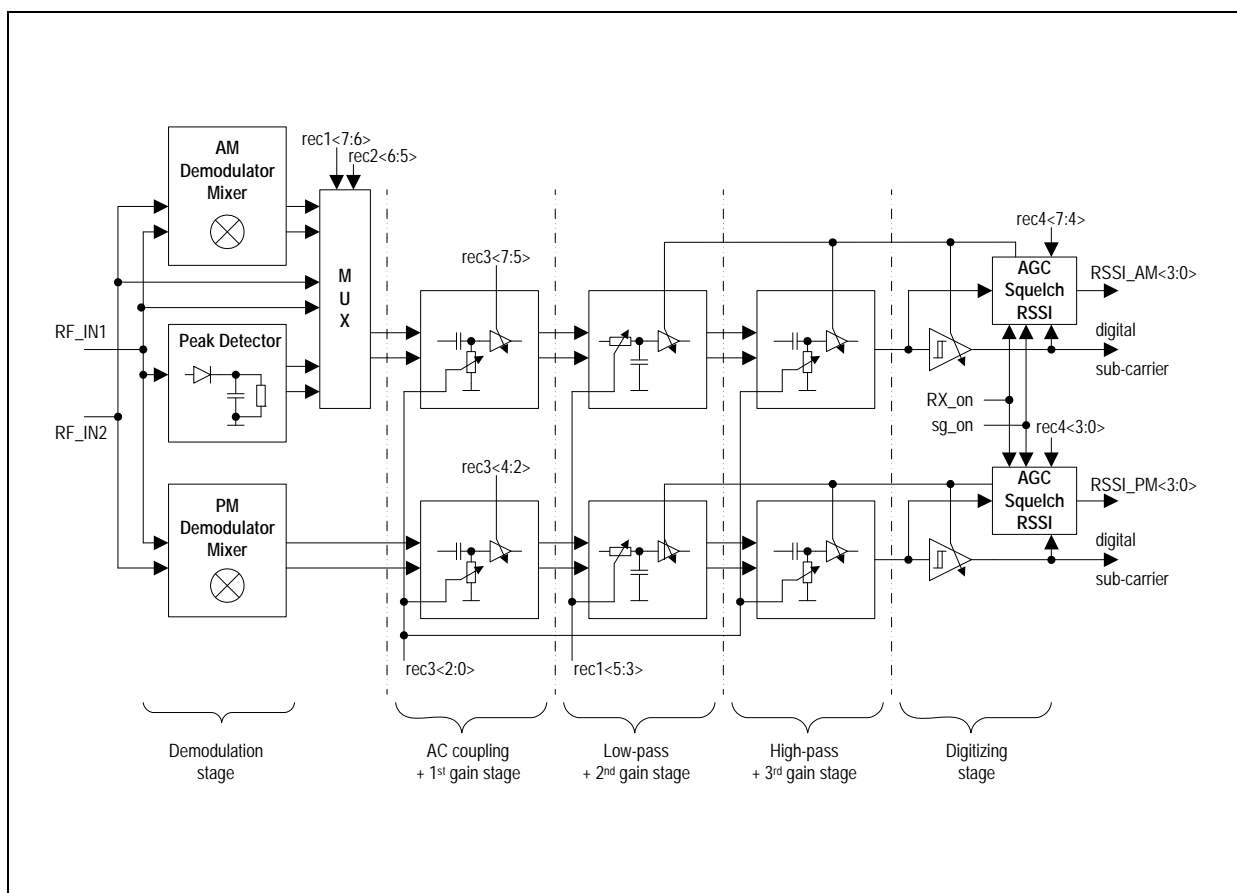

### Filtering and Gain Stages

The receiver chain has band pass filtering characteristics. Filtering is optimized to pass sub-carrier frequencies while rejecting carrier frequency and low frequency noise and DC component. Filtering and gain is implemented in three stages where the first and the last stage have the first order high pass characteristics, while the mid stage has second order low pass characteristic.

Gain and filtering characteristics can be optimized for current application by writing the [Receiver Configuration Register 1](#) (filtering), [Receiver Configuration Register 3](#) (gain in first stage) and [Receiver Configuration Register 4](#) (gain in second and third stage).

Gain of first stage is about 20dB and can be reduced in six 2.5 dB steps. There is also a special boost mode available, which boosts the maximum gain for additional 5.5 dB. In case of VHBR ( $f_c/8$  and  $f_c/4$ ) the gain is lower. The first stage gain can only be modified by writing [Receiver Configuration Register 3](#). The default setting of this register is the minimum gain. Default first stage zero is located at 60 kHz, it can also be lowered to 40kHz or 12 kHz by writing option bits in the [Receiver Configuration Register 1](#). The control of the first and third stage zeros is done with common control bits (see [Figure 17](#)).

Gain in the second and third stage is 23 dB and can be reduced in six 3 dB steps. Gain of these two stages is included in AGC and Squelch loops or can be manually set in [Receiver Configuration Register 4](#). Sending of direct command [Reset Rx Gain](#) is necessary to reset the AGC, Squelch and RSSI block. Sending this command clears the current Squelch setting and loads the gain reduction configuration from [Receiver Configuration Register 4](#) into the internal shadow registers of AGC/Squelch block. Second stage has a second order low pass filtering characteristic, the pass band is adjusted according to sub-carrier frequency using the bits lp2 to lp0 of the [Receiver Configuration Register 1](#). See [Figure 16](#) for -1dB cut-off frequency for different settings.

**Figure 16:**  
Low Pass Control

rec1<5> lp2	rec1<4> lp1	rec1<3> lp0	-1 dB point
0	0	0	1200 kHz
0	0	1	600 kHz
0	1	0	300 kHz
1	0	0	2 MHz
1	0	1	7 MHz
Other			Not used

**Figure 17:**  
First and Third Stage Zero Setting

rec1<2> h200	rec1<1> h80	rec1<0> z12k	First Stage Zero	Third Stage Zero
0	0	0	60 kHz	400 kHz
1	0	0	60 kHz	200 kHz
0	1	0	40 kHz	80 kHz
0	0	1	12 kHz	200 kHz
0	1	1	12 kHz	80 kHz
1	0	1	12 kHz	200 kHz
Other			Not used	

Figure 18 provides information on the recommended filter settings. For all supported operation modes and receive bit rates there is an automatic preset defined, additionally some alternatives are listed. Automatic preset is done by sending direct command [Analog Preset](#). There is no automatic preset for Steam and Transparent modes. Since selection of filter characteristics also modifies gain, the gain range for different filter settings is also listed.

**Figure 18:**  
**Receiver Filter Selection and Gain Range**

rec1<5:3> lp<2:0>	rec1<2> h200	rec1<1> h80	rec1<0> z12k	Gain [dB]					Comment
				Max All	Min1 Max23	Max1 Min23	Min All	With Boost	
000	0	0	0	43.4	28	26.4	11	49.8	Automatic preset for ISO14443A fc/128 and NFC Forum Type 1 Tag
000	1	0	0	44	29	27.5	12	49.7	Automatic preset for ISO14443B fc/128 ISO14443 fc/64
001	1	0	0	44.3	29	27	11.7	49.8	Recommended for 424/484 kHz sub-carrier
000	0	1	0	41.1	25.8	23.6	8.3	46.8	Alternative choice for ISO14443 fc/32 and fc/16
100	0	1	0	32	17	17.2	2	37.6	Automatic preset for ISO14443 fc/32 and fc/16 Alternative choice for fc/8 (1.7 kb/s)
100	0	0	0	32	17	17.2	2	37.6	Alternative choice for fc/8 (1.7 kb/s)
000	0	1	1	41.1	25.8	23.6	8.3	46.8	Automatic preset FeliCa (fc/64, fc/32) Alternative choice for ISO14443 fc/32 and fc/16
101	0	1	0	30	20	12	2	34	Alternative choice for fc/8 and fc/4
101	1	0	0	30	20	12	2	34	Automatic preset for fc/8 and fc/4
000	1	0	1	36.5	21.5	24.9	9.9	41.5	Automatic preset for NFCIP-1 (initiator and target)

### Digitizing Stage

Digitizing stage is producing a digital form of sub-carrier signal which is output of Receiver and input to Framing Logic. It is a window comparator with adjustable digitizing window (five possible settings, 3 dB steps, adjustment range from  $\pm 33$  mV to  $\pm 120$  mV). Adjustment of the digitizing window is included in AGC and Squelch loops or can be manually set in [Receiver Configuration Register 4](#).

### **AGC, Squelch and RSSI**

As mentioned above second and third gain stage gain and the Digitizing stage digitizing window are included in AGC and Squelch loops. Eleven settings are available, default state features minimum digitizer window and maximum gain, first four steps increase the digitizer window in 3 dB steps, next six steps additionally reduce the gain in 2<sup>nd</sup> and 3<sup>rd</sup> gain stage also in 3 dB steps. The initial setting with which Squelch and AGC start is defined in [Receiver Configuration Register 4](#). The [Gain Reduction State Register](#) displays the actual state of gain which results from Squelch, AGC and initial settings in [Receiver Configuration Register 4](#). During bit anticollision like Type A, the AGC should be disabled.

#### **Squelch**

This feature is designed for operation of receiver in noisy environment. The noise can come from tags in which processing of data sent by the reader is going on and an answer is being prepared. Noise can also be generated by noisy environment. This noise may be misinterpreted as start of transponder response which results in decoding error.

During execution of the Squelch procedure the output of Digitizing comparator is observed. In case there are more than two transitions on this output in 50  $\mu$ s time period, gain is reduced for 3 dB and output is observed during next 50  $\mu$ s. This procedure is repeated until number of transitions in 50  $\mu$ s is lower or equal to 2 or until maximum gain reduction is reached. This setting is cleared by sending direct command [Reset Rx Gain](#).

There are two possibilities of performing squelch: automatic mode and using direct command [Squelch](#).

- Automatic mode is started in case bit *sqm\_dyn* in the [Receiver Configuration Register 2](#) is set. It is activated automatically 18.88  $\mu$ s after end of Tx and is terminated with Mask Receive timer expire. This mode is primarily intended to suppress noise generated by tag processing during the time when the tag response is not expected (covered by Mask Receive timer).
- Command [Squelch](#) is accepted in case it is sent when signal *rx\_on* is low. It can be used in case the time window in which noise is present is known by the controller.

#### **AGC**

AGC (automatic gain control) is used to reduce gain to keep receiver chain out of saturation. In case gain is properly adjusted the demodulation process is also less influenced by system noise.

AGC action starts when signal *rx\_on* is asserted high and is reset when it is reset to low. At high to low transitions of the *rx\_on* the state of the receiver gain is stored in the [Gain Reduction State Register](#), therefore reading this register later gives the information of the gain setting used during last reception.



When AGC is switched on receiver gain is reduced so that the input to digitizer stage is not saturated. The AGC system comprises a window comparator which has its window 3.5 times larger than window of digitalization window comparator. When the AGC function is enabled gain is reduced until there are no transitions on its output. Such procedure assures that the input to digitalization window comparator is less than 3.5 times larger than its window.

AGC operation is controlled by the control bits *agc\_en*, *agc\_m* and *agc\_fast* in the [Receiver Configuration Register 2](#). Bit *agc\_en* enables the AGC operation; bit *agc\_m* defines the AGC mode while bit *agc\_alg* define the AGC algorithm.

Two AGC modes are available, AGC can operate during complete Rx process (as long as signal *rx\_on* is high) or it can be enabled only during first eight sub-carrier pulses.

Two AGC algorithms are available; AGC can either start by presetting of code  $4_h$  (max digitizer window, max gain) or by resetting the code to  $0_h$  (min digitizer window, max gain).

Algorithm with preset code is faster, therefore it is recommended for protocols with short SOF (like ISO14443A fc/128).

Default AGC settings are: AGC is enabled, AGC operates during complete Rx process, algorithm with preset is used.

### **RSSI**

The receiver also performs the RSSI (Received Signal Strength Indicator) measurement of both channels. RSSI measurement is started after rising edge of *rx\_on*. It stays active while signal *rx\_on* is high; while *rx\_on* is low it is frozen. It is a peak hold system; the value can only increase from initial zero value. Every time the AGC reduces the gain the RSSI measurement is reset and starts from zero. Result of RSSI measurements is 4-bit value which can be observed by reading the [RSSI Display Register](#). The LSB step is 2.8 dB, the maximum code is  $D_h$  ( $13_d$ ).

Since the RSSI measurement is of peak hold type the RSSI measurement result does not follow any variations in the signal strength (the highest value will be kept). In order to follow RSSI variation it is possible to reset RSSI bits and restart the measurement by sending direct command [Clear RSSI](#).

### **Receiver in NFCIP-1 Active Communication Mode**

There are several features built in receiver to enable reliable reception of active NFCIP-1 communication. All these settings are automatically preset by sending direct command [Analog Preset](#) after the NFCIP-1 mode has been configured. In addition to filtering options there are two NFC specific configuration bits stored in the [Receiver Configuration Register 3](#).

Bit *lim* enables clipping circuits which are positioned after first and second gain stages. The intention of clipping circuits is to limit the signal level for the following filtering stage (in case the NFC peer is close the input signal level can be quite high).

Bit *rg\_nfc* forces gain reduction of second and third filtering stage to -6dB while keeping the digitizer comparator window at maximum level.

### Capacitive Sensor

The Capacitive Sensor block provides a possibility of low power detection of tag presence.

The capacitive measurement system comprises two electrodes. One is excitation electrode emitting electrical field of a fixed frequency in range of few hundred kHz (CSO) and the second one is the sensing electrode (CSI). The amount of charge generated in sensing electrode represents the capacitance between the two electrodes. Capacitive sensor electrodes are tolerant to parasitic capacitance to ground (up to 25 pF) and to input leakage (up to 1 MΩ).

Since the charge on the sensing electrode is generated with the frequency of excitation electrode, synchronous rectifier is used to detect it. This ensures good rejection of interference and high tolerance to parasitic capacitances (to all nodes except the excitation electrode).

Capacitive sensor system depicted on figure below uses a synchronous rectifier to convert the AC charge generated by the excitation signal on the sensing electrode. This yields a DC output voltage, which is linearly proportional to the capacitance between the excitation and sensing electrode. The output DC voltage is converted by an AD converter in absolute mode. Result is stored in the [A/D Converter Output Register](#) (see also [A/D Converter](#)).

**Figure 19:**  
Capacitive Sensor Block Diagram

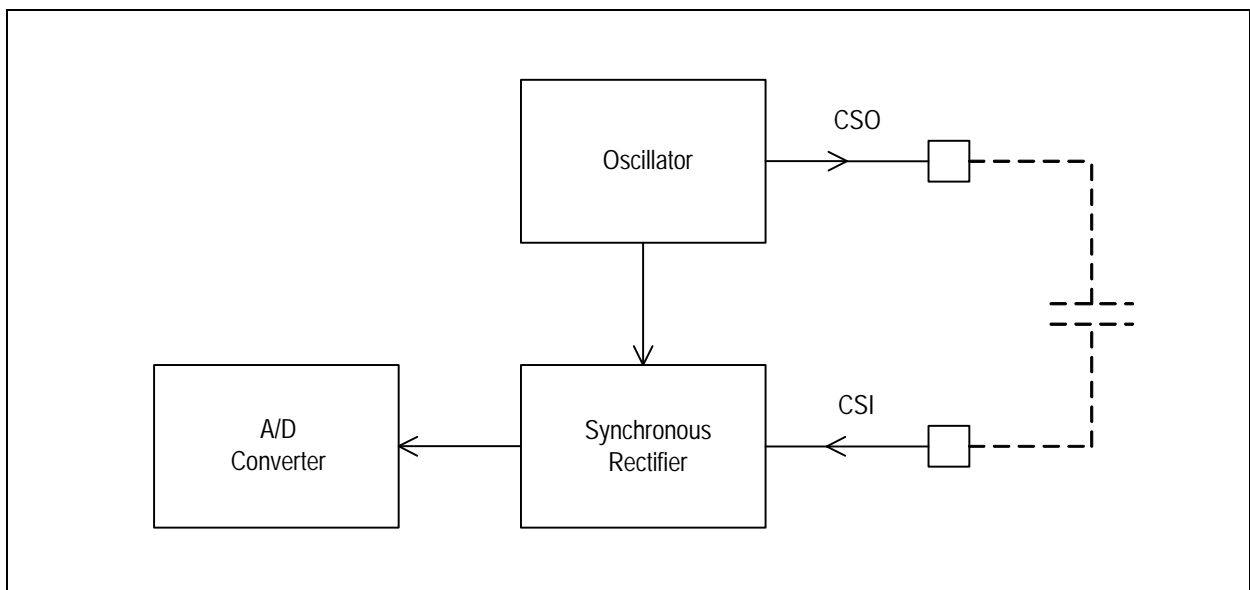

Any conductive object (human hand or tag's antenna windings) approaching the two electrodes changes the capacitance between the excitation and sensing electrode as it 'shortens' the distance between the two by providing conductance on the part of the path between the two electrodes.

Capacitance measurement is started by sending direct command [Measure Capacitance](#). The AS3911B can also be configured to periodically wake-up and perform the capacitance measurement. The result is compared to a stored reference or to an average of previous measurements and in case the difference is greater than a predefined value an IRQ is triggered to wake-up the controller (see also [Wake-Up Mode](#)).

Capacitor sensor gain can be adjusted by setting in [Capacitive Sensor Control Register](#). Default gain is 2.8 V/pF typ., maximum gain is 6.5 V/pF typ. Since LSB of AD converter corresponds to approximately 7.8mV, the default gain results in sensitivity of 2.8 fF/LSB (1.2 fF/LSB maximum).

Capacitance measurement duration is 200  $\mu$ s, current consumption during measurement is 1.1 mA typ. In case capacitive measurement is performed every 100 ms in Wake-up mode the resulting typical average consumption is 5.8  $\mu$ A (3.6  $\mu$ A is standby consumption in Wake-up mode).

### **Capacitor Sensor Calibration**

Capacitor sensor comprises calibration unit internally compensates the parasitic capacitances between CSI and CSO, thus leaving full measurement range for information about capacitance variation. 5 bits are used to control the calibration, minimum calibration step is 0.1 pF, calibration range is 3.1 pF. Calibration can be done manually by writing [Capacitive Sensor Control Register](#) or automatically by sending direct command [Calibrate Capacitive Sensor](#). The status of [Calibrate Capacitive Sensor](#) command and resulting calibration value are stored in the [Capacitive Sensor Display Register](#).

In order to avoid interference of Capacitive Sensor with Xtal oscillator and reader magnetic field and to assure repetitive results it is strongly recommended to perform capacitance measurement and calibration in Power-down mode only.

## Wake-Up Mode

Asserting the [Operation Control Register](#) bit *wu* while the other bits are set to 0 puts the AS3911B into the Wake-up mode which is used to perform low power detection of card presence. The AS3911B includes several possibilities of low power detection of a card presence (capacitive sensor, phase measurement, amplitude measurement). Low power 32 kHz RC oscillator and register configurable Wake-up timer are used to schedule periodic detection.

Usually the presence of a card is detected by so called polling. In this process the reader is periodically turned on and the controller activates the protocol to check whether a card is present. Such procedure consumes a lot of energy since reader field has to be turned on for 5 ms before a command can be issued.

Low power detection of card presence is performed by detecting a change in reader environment, which is produced by presence of a card. When a change is detected, an interrupt is sent to the controller. As a result, the controller can activate the protocol for tag detection.

In the Wake-up mode the AS3911B periodically performs the configured measurements and sends an IRQ to the controller, which is in deep sleep to minimize the current consumption, only when a difference to the build in reference is detected.

Detection of card presence can be done by performing phase, amplitude and capacitive sensor measurements.

Presence of a card close to the reader antenna coil produces due to the magnetic coupling of the two coils a change of the antenna LC tank signal phase and amplitude. The reader field activation time needed to perform the phase or the amplitude measurement is extremely short (~20  $\mu$ s) comparing to the activation time needed to send a protocol activation command. Additionally the power level during the measurement can be lower than the power level during normal operation since the card does not have to be powered to produce the coupling effect. The emitted power can be reduced by increasing the [RFO Normal Level Definition Register](#).

Capacitance Sensor detects a change of the parasite capacitance between the two excitation electrodes which is caused by a card antenna and a hand holding it. See [Capacitive Sensor](#) for a detailed information on the capacitive sensor.

The registries on locations from 31<sub>h</sub> to 3D<sub>h</sub> are dedicated to Wake-up configuration and display. The [Wake-Up Timer Control Register](#) is the main Wake-up mode configuration register. The timeout period between the successive detections and the measurements which are going to be used are selected in this register. Timeouts in the range from 10 ms to 800 ms are

available, 100 ms is the default value. Any combination of available measurements can be selected (one, two or all of them).

The following twelve registers (32<sub>h</sub> to 3D<sub>h</sub>) are configuring the three possible detection measurements and storing the results, four registers are used for each measurement.

An IRQ is sent when the difference between a measured value and reference value is larger than configured threshold value. There are two possibilities how to define the reference value:

- The AS3911B can calculate the reference based on previous measurements (auto-averaging)
- The controller determines the reference and stores it in a register

The first register in the series of four is the Measurement Configuration Register (see for e.g. [Amplitude Measurement Configuration Register](#)). The difference to reference which triggers the IRQ, the method of reference value definition and the weight of last measurement result in case of auto-averaging are defined in this register. The next register is storing the reference value in case the reference is defined by the controller. The following two registers are display registers. The first one stores the auto-averaging reference; the second one stores the result of the last measurement.

Wake-up mode configuration registers have to be configured before wake-up mode is actually entered. Any modification of Wake-up mode configuration while it is active may result in unpredictable behavior.

### **Auto-Averaging**

In case of auto-averaging the reference value is recalculated after every measurement. The last measurement value, the old reference value and the weight are used in this calculation. The following formula is used to calculate the new reference value.

$$(EQ1) \quad \text{NewAverage} = \text{OldAverage} + \frac{\text{MeasuredValue} - \text{OldAverage}}{\text{Weight}}$$

The calculation is done on 10 bits to have sufficient precision. The auto-averaging process is initialized when Wake-up mode is first time entered after initialization (power-up or using [Set Default](#) command). The initial value is taken from the Measurement Display Register (for example [Amplitude Measurement Display Register](#)) until the content of this register is not zero.

Every Measurement Configuration register contains a bit which defines whether the measurement which causes an interrupt is taken in account for the average value calculation (for example bit **am\_aam** of the [Amplitude Measurement Configuration Register](#)).

## Quartz Crystal Oscillator

The quartz crystal oscillator can operate with 13.56 MHz and 27.12 MHz crystals. The operation of quartz crystal oscillator is enabled when the [Operation Control Register](#) bit *en* is set to one. An interrupt is sent to inform the microcontroller when the oscillator frequency is stable (see [Main Interrupt Register](#)).

The status of oscillator can be observed by observing the [Auxiliary Display Register](#) bit *osc\_ok*. This bit is set to '1' when oscillator frequency is stable.

The oscillator is based on an inverter stage supplied by controlled current source. A feedback loop is controlling the bias current in order to regulate amplitude on XTI pin to  $1 V_{pp}$ . In order to enable a fast reader start-up an interrupt is sent when oscillator amplitude exceeds  $750 mV_{pp}$ .

Division by two assures that 13.56 MHz signal has a duty cycle of 50% which is better for the Transmitter performance (no PW distortion). Use of 27.12 MHz crystal is therefore recommended for better performance.

In case of 13.56 MHz crystal, the bias current of stage which is digitizing oscillator signal is increased to assure as low PW distortion as possible.

Please note that in case of VHBR reception (bit rates  $f_c/8$  and above) it is mandatory to use the 27.12 MHz crystal since high frequency clock is needed for receive framing.

The oscillator output is also used to drive a clock signal output pin (MCU\_CLK), which can be used by the external microcontroller. The MCU\_CLK pin is configured in the [IO Configuration Register 2](#).

## Timers

The AS3911B contains several timers which eliminate the need to run counters in the controller, thus reducing the effort of the controller code implementation and improve portability of code to different controllers.

Every timer has one or more associated configuration registers in which the timeout duration and different operating modes are defined. These configuration registers have to be set while the corresponding timer is not running. Any modification of timer configuration while the timer is active may result in unpredictable behavior.

All timers except the Wake-up timer are stopped by direct command [Clear](#).

**Exception:** In case bit *nrt\_emv* in the [General Purpose and No-Response Timer Control Register](#) is set to one, the No-Response Timer is not stopped.

### **Mask Receive Timer and No-Response Timer**

Mask Receive Timer and No-Response Timer are both automatically started at the end of transmission (at the end of EOF).

#### **Mask Receive Timer**

The Mask Receive Timer is blocking the receiver and reception process in framing logic by keeping the *rx\_on* signal low after the end of Tx during the time the tag reply is not expected. While the Mask Receive Timer is running, the Squelch is automatically turned on (if enabled). Mask Receive Timer does not produce an IRQ.

The Mask Receive Timer timeout is configured in the [Mask Receive Timer Register](#).

In the NFCIP-1 active communication mode the Mask Receive Timer is started when the peer NFC device (a device with which communication is going on) switches on its field.

The Mask Receive Timer has a special use in the low power Initial NFC Target Mode. After the initiator field has been detected the controller turns on the oscillator, regulator and receiver. Mask Receive Timer is started by sending direct command [Start Mask-Receive Timer](#). After the Mask Receive Timer expires the receiver output starts to be observed to detect start of the initiator message. In this mode the Mask Receive Timer clock is additionally divided by eight it (one count is  $512/f_c$ ) to cover range up to  $\sim 9.6$  ms.

#### **No-Response Timer**

As its name indicates this timer is intended to observe whether a tag response was detected in a configured time started by end of transmission. The *l\_nre* flag in the [Timer and NFC Interrupt Register](#) is signaling interrupt events resulting from this timer timeout.

The No-Response Timer is configured by writing two No-Response Timer setting registers: [No-Response Timer Register 1](#) and [No-Response Timer Register 2](#). Operation options of the No-Response Timer are defined by setting bits *nrt\_emv* and *nrt\_step* in the [General Purpose and No-Response Timer Control Register](#).

Bit *nrt\_step* configures the time step of the No-Response Timer. Two steps are available,  $64/f_c$  (4.72  $\mu$ s), which covers range up to 309 ms and  $4096/f_c$ , which covers range up to 19.8 s.

Bit *nrt\_emv* controls the timer operation mode:

- When this bit is set to 0 (default mode) the IRQ is produced in case the No-Response Timer expires before a start of a tag reply is detected **and rx\_on is forced to low to stop receiver process**. In the opposite case, when start of a tag reply is detected before timeout, the timer is stopped, and no IRQ is produced.
- When this bit is set to 1 the timer unconditionally produces an IRQ when it expires, it is also not stopped by direct command [Clear](#). This means that IRQ is independent of the fact whether or not a tag reply was detected. In case at the moment of timeout a tag reply is being processed

no other action is taken, in the opposite case, when no tag response is being processed additionally the signal `rx_on` is forced to low to stop receive process.

The No-Response Timer can also be started using direct command [Start No-Response Timer](#). The intention of this command is to extend the No-Response Timer timeout beyond the range defined in the No-Response Timer control registers. In case this command is sent while the timer is running, it is reset and restarted. In NFCIP-1 active communication mode the No-Response Timer cannot be started using the direct command.

In case this timer expires before the peer NFC device (a device with which communication is going on) switches on its field an interrupt is sent.

*In all modes, where timer is set to nonzero value, it is a must that `M_txe` is not set and interrupt `I_txe` is read via SPI for synchronization between transmitter and timer.*

### **General Purpose Timer**

The triggering of the General Purpose Timer is configured by setting the [General Purpose and No-Response Timer Control Register](#). It can be used to survey the duration of reception process (triggering by start of reception, after SOF) or to timeout the PCD to PICC response time (triggered by end of reception, after EOF). In the NFCIP-1 active communication mode it is used to timeout the field switching off. In all cases an IRQ is sent when it expires.

The General Purpose Timer can also be started by sending the direct command [Start General Purpose Timer](#). In case this command is sent while the timer is running, it is reset and restarted.

### **Wake-Up Timer**

Wake timer is primarily used in the Wake-up mode (see [Wake-Up Mode](#)). Additionally it can be used by sending a direct command [Start Wake-Up Timer](#). This command is accepted in any operation mode except Wake-up mode. When this command is sent the RC oscillator, which is used as clock source for wake-up timer is started, timeout is defined by setting in the [Wake-Up Timer Control Register](#). When the timer expires, an IRQ with the `I_wt` flag in the [Error and Wake-Up Interrupt Register](#) is sent.

Wake-Up Timer is useful in the Low Power operation mode, in which other timers cannot be used (in the Low Power operation mode the crystal oscillator, which is clock source for the other timers, is not running). Please note that the tolerance of Wake-Up Timer timeout is defined by tolerance of the RC oscillator.



## A/D Converter

The AS3911B contains an 8-bit successive approximation A/D converter. Input to A/D converter can be multiplexed from different sources to be used in several direct commands and adjustment procedures. The result of last A/D conversion is stored in the [A/D Converter Output Register](#). Typical conversion time is  $224/f_c$  (16.5  $\mu$ s).

The A/D converter has two operating modes, absolute and relative.

- In absolute mode the low reference is 0V and the high reference is 2V. This means that A/D converter input range is from 0 to 2V,  $00_h$  code means input is 0V or lower,  $FF_h$  means that input is 2V - 1LSB or higher, LSB is 7.8125 mV.
- In relative mode low reference is 1/6 of VSP\_A and high reference is 5/6 of VSP\_A, so the input range is from 1/6 VSP\_A to 5/6 VSP\_A.

Relative mode is only used in phase measurement (phase detector output is proportional to power supply). In all other cases absolute mode is used.

## Phase and Amplitude Detector

This block is used to provide input to A/D Converter to perform measurements of amplitude and phase, expected by direct commands [Measure Amplitude](#) and [Measure Phase](#). Several phase and amplitude measurements are also performed by direct commands [Calibrate Modulation Depth](#) and [Calibrate Antenna](#).

### Phase Detector

The phase detector is observing phase difference between the transmitter output signals (RFO1 and RFO2) and the receiver input signals RF11 and RF12, which are proportional to the signal on the antenna LC tank. These signals are first passed by digitizing comparators. Digitized signals are processed by a phase detector with a strong low pass filter characteristics to get average phase difference. The Phase Detector output is inversely proportional to the phase difference between the two inputs. The 90° phase shift results in VSP\_A/2 output voltage, in case both inputs are in phase output voltage is VSP\_A in case they are in opposite phase output voltage is zero. During execution of direct command [Measure Phase](#) this output is multiplexed to A/D Converter input (A/D Converter is in relative mode during execution of command [Measure Phase](#)). Since the A/D converter range is from 1/6 VSP\_A to 5/6 VSP\_A the actual phase detector range is from 30° to 150°. Figures below depict the two inputs and output of phase detector in case of 90° and 135° phase shift.

**Figure 20:**  
Phase Detector Inputs and Output in case of 90° Phase Shift

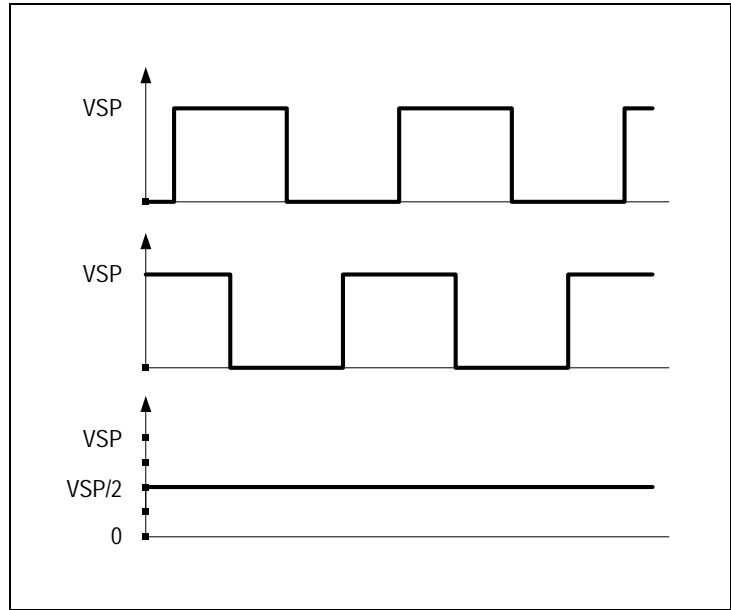

**Figure 21:**  
Phase Detector Inputs and Output in case of 135° Phase Shift

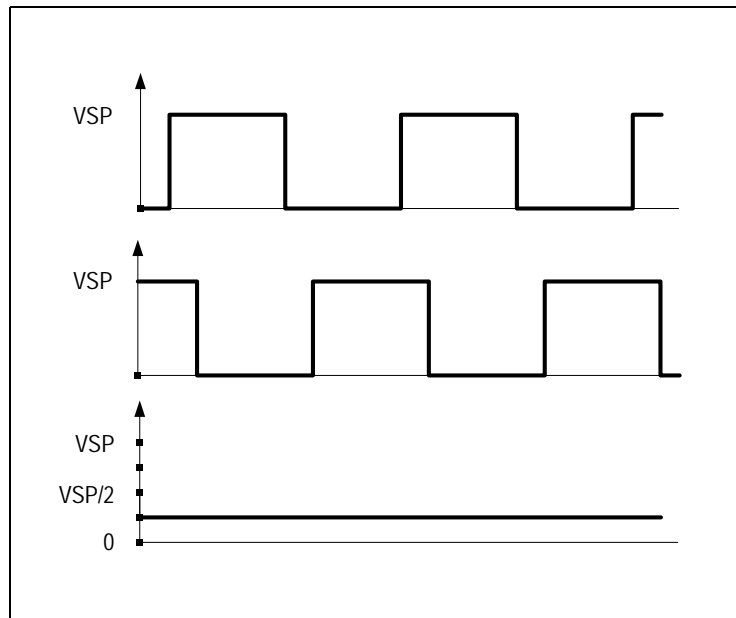

**Amplitude Detector**

Signals from pins RF11 and RF12 are used as inputs to the self-mixing stage. Output of this stage is DC voltage proportional to amplitude of signal on pins RF11 and RF12. During execution of direct command [Measure Amplitude](#) this output is multiplexed to A/D Converter input.

## External field Detector

The External Field Detector is used to detect the presence of an external device generating an RF field. It is automatically switched on in NFCIP-1 active communication modes; it can also be used in other modes. The External Field Detector supports two different detection thresholds, Peer Detection Threshold and Collision Avoidance Threshold. The two thresholds can be independently set by writing the [External Field Detector Threshold Register](#). The actual state of the External Field Detector output can be checked by reading the [Auxiliary Display Register](#). Input to this block is the signal from the RFI1 pin.

### **Peer Detection Threshold**

This threshold is used to detect the field emitted by peer NFC device with which NFC communication is going on (initiator field in case the AS3911B is a target and the opposite, target field in case the AS3911B is an initiator). It can be selected in the range from 75 mV<sub>pp</sub> to 800 mV<sub>pp</sub>. When this threshold is enabled the External Field Detector is in low power mode. An interrupt is generated when an external field is detected and also when it is switched off. With such implementation it can also be used to detect the moment when the external field disappears. This is useful to detect the moment when the peer NFC device (it can be either an initiator or a target) has stopped emitting an RF field.

The External Field Detector is automatically enabled in the low power Peer Detection mode when NFCIP-1 mode (initiator or target) is selected in the [Bit Rate Definition Register](#). Additionally it can be enabled by setting bit *en\_fd* in the [Auxiliary Definition Register](#).

### **Collision Avoidance Threshold**

This threshold is used during the RF Collision Avoidance sequence which is executed by sending NFC Field ON commands (see [NFC Field ON Commands](#)). It can be selected in the range from 25 mV<sub>pp</sub> to 800 mV<sub>pp</sub>.

## Power Supply System

The AS3911B features two positive supply pins,  $V_{DD}$  and  $V_{DD\_IO}$ .  $V_{DD}$  is the main power supply pin. It supplies the AS3911B blocks through three regulators (VSP\_A, VSP\_D and VSP\_RF).  $V_{DD}$  range from 2.4 to 5.5 V is supported.

$V_{DD\_IO}$  is used to define supply level for digital communication pins (/SS, MISO, MOSI, SCLK, IRQ, MCU\_CLK). Digital communication pins interface to the AS3911B logic through level shifters, therefore the internal supply voltage can be either higher or lower than  $V_{DD\_IO}$ .  $V_{DD\_IO}$  range from 1.65 V to 5.5 V is supported.

Figure 23 shows the building blocks of the AS3911B power supply system. It contains three regulators, a power-down support block, a block generating analog reference voltage (AGD) and a block performing automatic power supply adjustment procedure. The three regulators are providing supply to analog blocks (VSP\_A), logic (VSP\_D) and transmitter (VSP\_RF). The use of VSP\_A and VSP\_D regulators is mandatory at 5V power supply to provide regulated voltage to analog and logic blocks which only use 3.3 V devices. The use of VSP\_A and VSP\_D regulators at 3 V supply and VSP\_RF regulator at any supply voltage is recommended to improve system PSRR. Regulated voltage can be adjusted automatically to have maximum possible regulated voltage while still having good PSRR. All regulator pins also have corresponding negative supply pins which are externally connected to ground potential (VSS). The reason for separation is in decoupling of noise induced by voltage drops on the internal power supply lines. Figure 13 and Figure 14 depict typical AS3911B application schematics with all regulators used. All regulator pins and AGD voltage are buffered with capacitor. Recommended blocking capacitor values can be found in the table below are 2.2  $\mu$ F in parallel with 10 nF, for pin AGD 1  $\mu$ F in parallel with 10 nF is suggested.

**Figure 22:**  
Recommended Blocking Capacitor Values

Pins	Recommended Capacitors
AGD-VSS	1 $\mu$ F    10nF
VSP_A-VSN_A VSP_D-VSN_D	2.2 $\mu$ F    10nF 2.2 $\mu$ F    10nF
VSP_RF-VSN_RF	2.2 $\mu$ F    10nF

**Figure 23:**  
The AS3911B Power Supply System

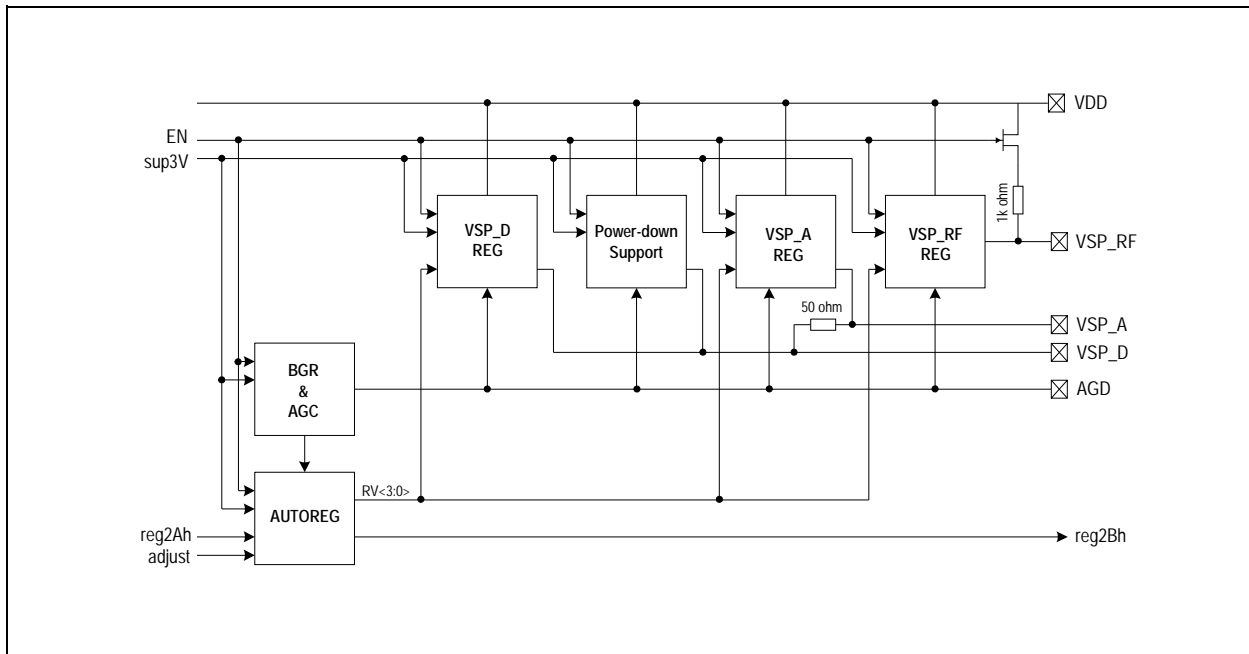

Regulators have two basic operation modes depending on supply voltage, 3.3 V supply mode (max 3.6 V) and 5 V supply mode (max 5.5V). The supply mode is set by writing bit *sup3V* in the [IO Configuration Register 2](#). Default setting is 5 V so this bit has to be set to one after power-up in case of 3.3 V supply.

In 3.3 V mode all regulators are set to the same regulated voltage in range from 2.4 V to 3.4 V, while in 5 V only the VSP\_RF can be set in range from 3.9 V to 5.1 V, while VSP\_A and VSP\_D are fixed to 3.4 V.

[Figure 23](#) depicts signals controlling the power supply system. The regulators are operating when signal *en* is high (*en* is configuration bit in [Operation Control Register](#)). When signal *en* is low the AS3911B is in low power Power-down mode. In this mode consumption of the power supply system is also minimized.

### VSP\_RF Regulator

The intention of this regulator is to improve PSRR of the Transmitter (the noise of the Transmitter power supply is emitted and fed back to the Receiver). The VSP\_RF regulator operation is controlled and observed by writing and reading two regulator registers:

- **Regulator Voltage Control Register** controls the regulator mode and regulated voltage. Bit *reg\_s* controls regulator mode. In case it is set to 0 (default state) the regulated voltage is set using direct command [Adjust Regulators](#). When bit *reg\_s* is asserted to 1 regulated voltage is defined by bits *rege\_3* to *rege\_1* of the same register. The regulated voltage adjustment range depends on the power supply mode. In case of 5 V supply mode the adjustment range is between 3.9 V and 5.1 V in steps of 120 mV, in case of 3.3 V supply mode the adjustment range is from 2.4 V to 3.4 V with steps of 100 mV. Default regulated voltage is the maximum one (5.1 V and 3.4 V in case of 5 V and 3.3 V supply mode respectively).
- **Regulator and Timer Display Register** is a read only register which displays actual regulated voltage when regulator is operating. It is especially useful in case of automatic mode, since the actual regulated voltage, which is result of direct command [Adjust Regulators](#), can be observed.

The VSP\_RF regulator also includes a current limiter which limits the regulator typically to current of 200 mA<sub>rms</sub> in normal operation (500 mA in case of short). In case the Transmitter output current higher the 200 mA<sub>rms</sub> is required, VSP\_RF regulator cannot be used to supply the Transmitter, VSP\_RF has to be externally connected to V<sub>DD</sub> (connection of VSP\_RF to supply voltage higher than V<sub>DD</sub> is not allowed).

The voltage drop of the Transmitter current is the main source of the AS3911B power dissipation. This voltage drop is composed of drop in the Transmitter driver and in the drop on VSP\_RF regulator. Due to this it is recommended to set regulated voltage using direct command [Adjust Regulators](#). It results in good power supply rejection ration with relatively low dissipated power due to regulator voltage drop.

In Power-down mode the VSP\_RF regulator is not operating. VSP\_RF pin is connected to V<sub>DD</sub> through 1 kΩ resistor. Connection through resistors assures smooth power-up of the system and a smooth transition from Power-down mode to other operating modes.

### **VSP\_A and VSP\_D Regulators**

VSP\_A and VSP\_D regulators are used to supply the AS3911B analog and digital blocks respectively. In 3.3 V mode, VSP\_A and VSP\_D regulator are set to the same regulated voltage as the VSP\_RF regulator, in 5 V mode VSP\_A and VSP\_D regulated voltage is fixed to 3.4 V.

The use of VSP\_A and VSP\_D regulators is obligatory in 5 V mode since analog and digital blocks supplied with these two pins contain low voltage transistors which support maximum supply voltage of 3.6 V. In 3.3 supply mode the use of regulators is strongly recommended in order to improve PSRR of analog processing.

For low cost applications it is possible to disable the VSP\_D regulator and to supply digital blocks through external short between VSP\_A and VSP\_D (configuration bit *vspd\_off* in the [IO Configuration Register 2](#)). In case VSD\_D regulator is disabled VSP\_D can alternatively be supplied from  $V_{DD}$  (in 3.3 V mode only) in case VSP\_A is not more than 300 mV lower than  $V_{DD}$ .

### **Power-Down Support Block**

In the Power-down mode the regulators are disabled in order to save current. In this mode a low power Power-down support block which maintains the VSP\_D and VSP\_A in below 3.6 V is enabled. Typical regulated voltage in this mode is 3.1 V at 5 V supply and 2.2 V at 3 V supply. When 3.3 V supply mode is set the Power-down support block is disabled, its output is connected to  $V_{DD}$  through 1 k $\Omega$  resistor.

Typical consumption of Power-down support block is 600 nA at 5 V supply.

### **Measurement of Supply Voltages**

Using direct command [Measure Power Supply](#) it is possible to measure  $V_{DD}$  and regulated voltages VSP\_A, VSP\_D, and VSP\_RF.

### Communication to External Microcontroller

The AS3911B is a slave device and the external microcontroller initiates all communication. Communication is performed by a 4-wire Serial Peripheral Interface (SPI). The AS3911B asks microcontroller for its attention by sending an interrupt (pin IRQ). In addition, the microcontroller can use clock signal available on pin MCU\_CLK when the oscillator is running.

#### Serial Peripheral Interface (SPI)

While signal /SS is high the SPI interface is in reset, while it is low the SPI interface is enabled. It is recommended to keep signal /SS high whenever the SPI interface is not in use. MOSI is sampled at the falling edge of SCLK. All communication is done in blocks of 8 bits (bytes). First two bits of first byte transmitted after high to low transition of /SS define SPI operation mode. MSB bit is always transmitted first (valid for address and data). Read and Write modes support address auto-incrementing, which means that in case after the address and first data byte some additional data bytes are sent (read), they are written to (read from) addresses incremented by '1'. [Figure 26](#) defines possible modes.

MISO output is usually in tristate, it is only driven when output data is available. Due to this the MOSI and the MISO can be externally shorted to create a bidirectional signal.

During the time the MISO output is in tristate, it is possible to switch on a 10 kΩ pull down by activating option bits *miso\_pd1* and *miso\_pd2* in the [IO Configuration Register 2](#).

**Figure 24:**  
Serial Data Interface (4-wire interface) Signal Lines

Name	Signal	Signal Level	Description
/SS	Digital input	CMOS	SPI Enable (active low)
MOSI	Digital input	CMOS	Serial data input
MISO	Digital output with tristate	CMOS	Serial data output
SCLK	Digital input	CMOS	Clock for serial communication



**Figure 25:**  
Signal to Microcontroller

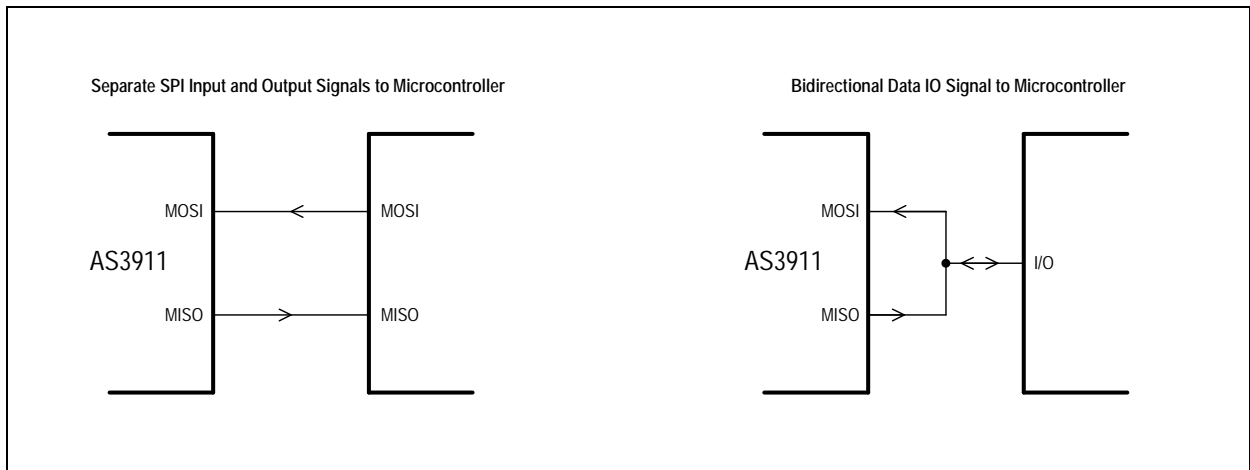

Figure 26 provides information on the SPI operation modes. Reading and writing of registers is possible in any AS3911B operation mode. FIFO operations are possible in case *en* (bit 7 of the [Operation Control Register](#)) is set and Xtal oscillator frequency is stable.

**Figure 26:**  
SPI Operation Modes

MODE	MODE Pattern (communication bits)								MODE Related Data
	MODE		Trailer						
	M1	M0	C5	C4	C3	C2	C1	C0	
Register Write	0	0	A5	A4	A3	A2	A1	A0	Data byte (or more bytes in case of auto-incrementing)
Register Read	0	1	A5	A4	A3	A2	A1	A0	Data byte (or more bytes in case of auto-incrementing)
FIFO Load	1	0	0	0	0	0	0	0	One or more bytes of FIFO data
FIFO Read	1	0	1	1	1	1	1	1	One or more bytes of FIFO data
Direct Command Mode	1	1	C5	C4	C3	C2	C1	C0	

### Writing of Data to Addressable Registers (Write Mode)

Following figures show cases of writing a single byte and writing multiple bytes with auto-incrementing address. After the SPI operation mode bits, the address of register to be written is provided. Then one or more data bytes are transferred from the SPI, always from the MSB to the LSB. The data byte is written in register on falling edge of its last clock. In case the communication is terminated by putting /SS high before a packet of 8 bits composing one byte is sent, writing of this register is not performed. In case the register on the defined address does not exist or it is a read only register no write is performed.

**Figure 27:**  
SPI Communication: Writing of Single Byte

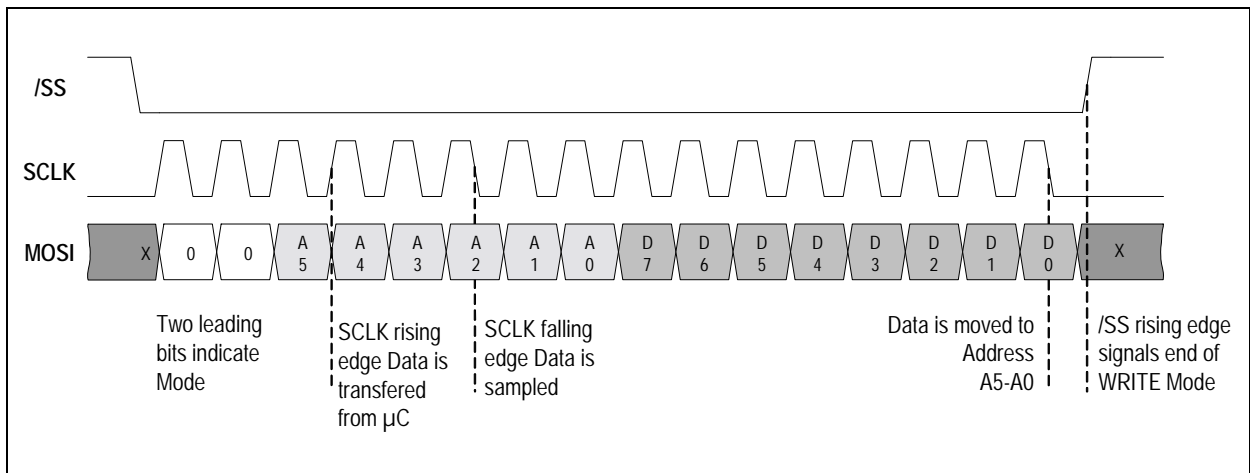

**Figure 28:**  
SPI Communication: Writing of Multiple Bytes

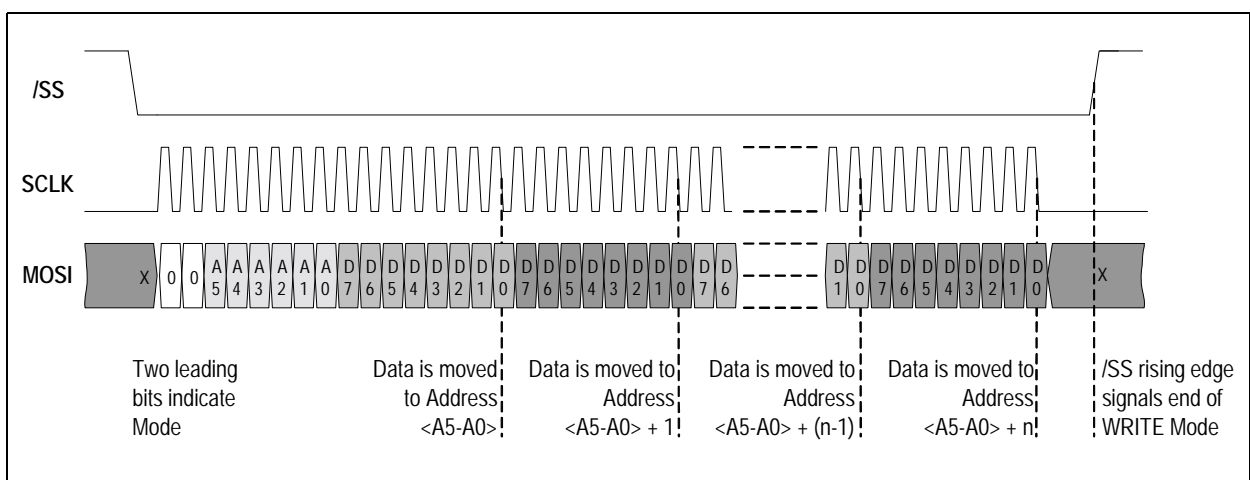

### Reading of Data from Addressable Registers (Read Mode)

After the SPI operation mode bits the address of register to be read has to be provided from the MSB to the LSB. Then one or more data bytes are transferred to MISO output, always from the MSB to the LSB. As in case of the write mode also the read mode supports auto-incrementing address.

MOSI is sampled at the falling edge of SCLK (like shown in the following diagrams), data to be read from the AS3911B internal register is driven to MISO pin on rising edge of SCLK and is sampled by the master at the falling edge of SCLK.

In case the register on defined address does not exist all 0 data is sent to MISO.

Figure 29 provides an example for reading of single byte.

**Figure 29:**  
SPI Communication: Reading of Single Byte

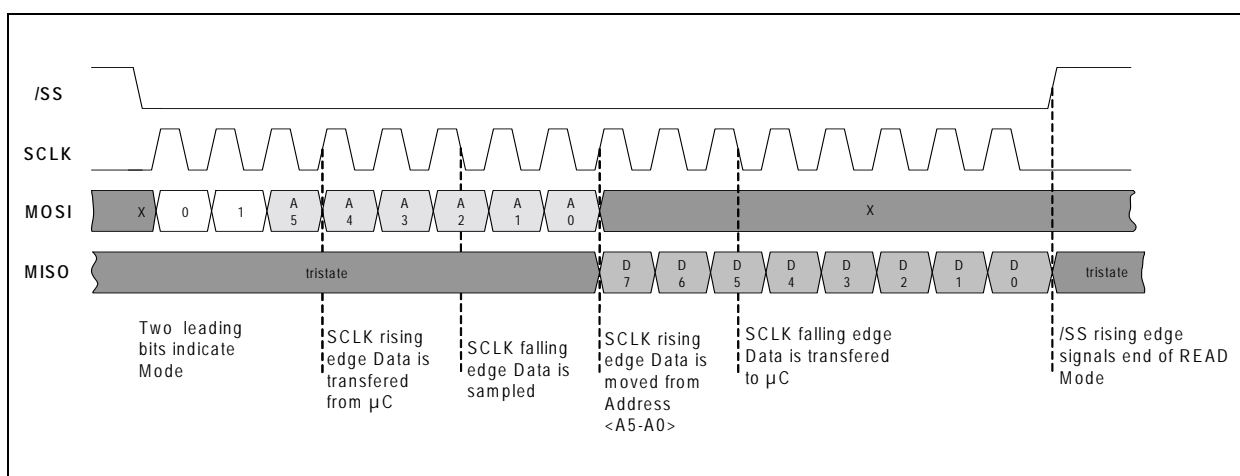

### Loading Transmitting Data into FIFO

Loading the transmitting data into the FIFO is similar to writing data into an addressable registers. Difference is that in case of loading more bytes all bytes go to the FIFO. SPI operation mode bits 10 indicate FIFO operations. In case of loading transmitting data into FIFO all bits <C5 – C0> are set to 0. Then a bit-stream, the data to be sent (1 to 96 bytes), can be transferred. In case the command is terminated by putting /SS high before a packet of 8 bits composing one byte is sent, writing of that particular byte in FIFO is not performed.

Figure 30 shows how to load the Transmitting Data into the FIFO.

**Figure 30:**  
**SPI Communication: Loading of FIFO**

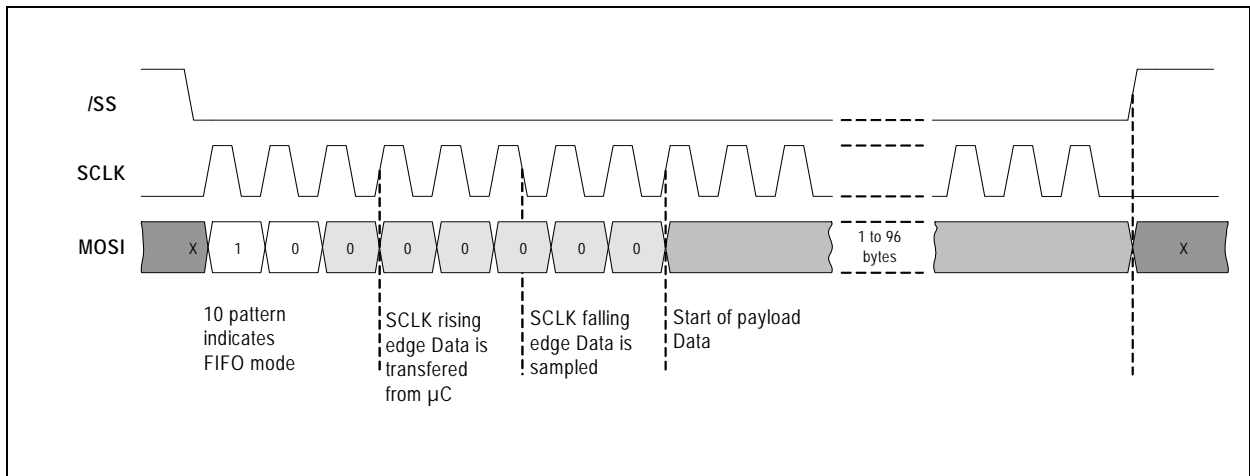

**Reading Received Data from FIFO**

Reading received data from the FIFO is similar to reading data from an addressable registers. Difference is that in case of reading more bytes they all come from the FIFO. SPI operation mode bits 10 indicate FIFO operations. In case of reading the received data from the FIFO all bits <C5 – C0> are set to 1. On the following SCLK rising edges the data from FIFO appears as in case of read data from addressable registers. In case the command is terminated by putting /SS high before a packet of 8 bits composing one byte is read that particular byte is considered unread and will be the first one read in next FIFO read operation.

**Figure 31:**  
**SPI Communication: Reading of FIFO**

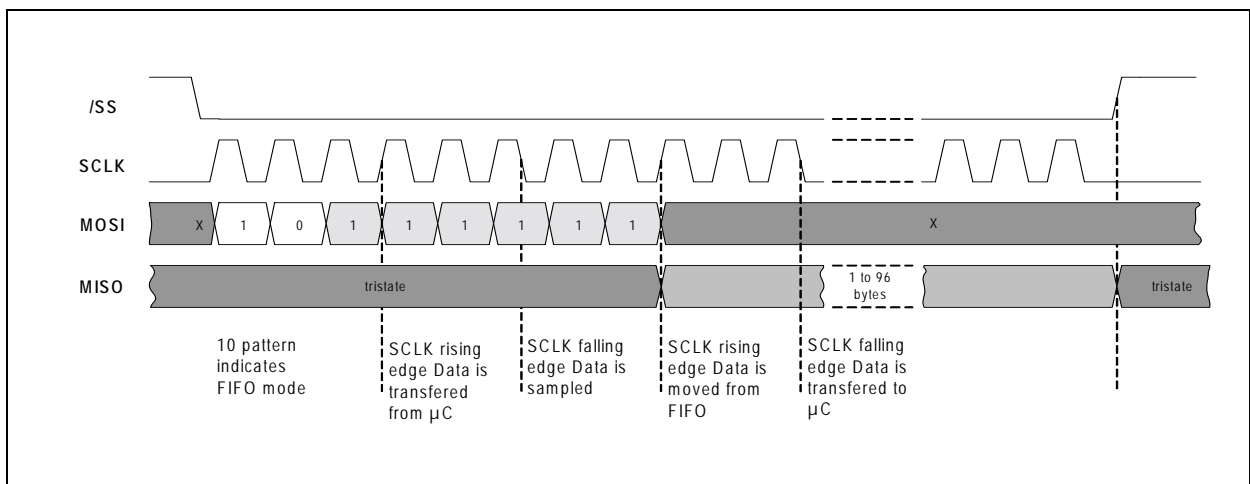

### Direct Command Mode

Direct Command Mode has no arguments, so a single byte is sent. SPI operation mode bits 11 indicate Direct Command Mode. The following six bits define command code, sent MSB to the LSB. The command is executed on falling edge of last clock.

While execution of some Direct Commands is immediate, there are others which start a process of certain duration (calibration, measurement...). During execution of such commands it is not allowed to start another activity over the SPI interface. After execution of such a command is terminated an IRQ is sent.

**Figure 32:**  
SPI Communication: Direct Command

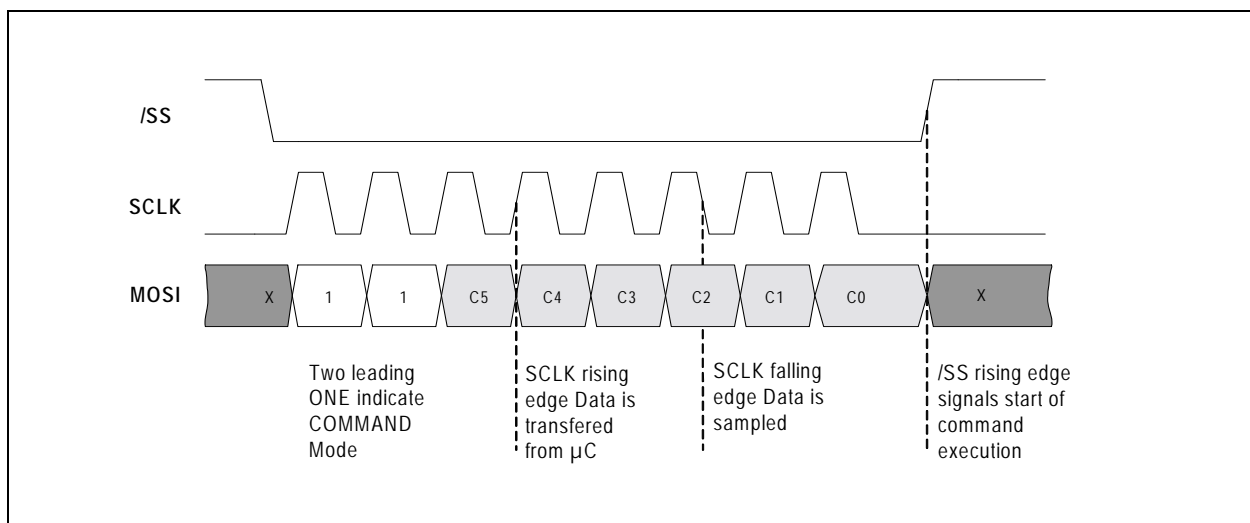

### Direct Command Chaining

Direct commands with immediate execution can be followed by another SPI mode (Read, Write or FIFO) without deactivating /SS signal in between.

**Figure 33:**  
Direct Command Chaining

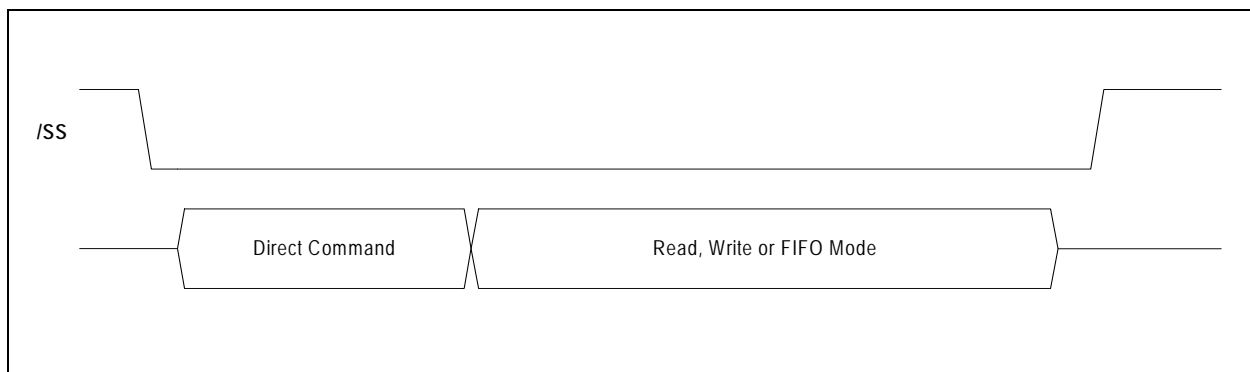

**SPI Timing**

**Figure 34:**  
SPI Timing

Symbol	Parameter	Min	Typ	Max	Unit	Notes
<b>General Timing (<math>V_{DD} = V_{DD\_IO} = VSP\_D = 3.3\text{ V}</math>, Temperature <math>25^{\circ}\text{C}</math>)</b>						
$T_{SCLK}$	SCLK period	100			ns	$T_{SCLK} = T_{SCLKL} + T_{SCLKH}$ , use of shorter SCLK period may lead to incorrect operation of FIFO
$T_{SCLKL}$	SCLK low	40		*1	ns	
$T_{SCLKH}$	SCLK high	40			ns	
$T_{SSH}$	SPI reset (/SS high)	100			ns	
$T_{NCSL}$	/SS falling to SCLK rising	25			ns	First SCLK pulse
$T_{NC SH}$	SCLK falling to /SS rising	25 (tbd)			ns	Last SCLK pulse
$T_{DIS}$	Data in setup time	10			ns	
$T_{DIH}$	Data in hold time	10			ns	
<b>Read Timing (<math>V_{DD} = V_{DD\_IO} = VSP\_D = 3.3\text{ V}</math>, Temperature <math>25^{\circ}\text{C}</math>, <math>C_{LOAD} \leq 50\text{ pF}</math>)</b>						
$T_{DOD}$	Data out delay		20		ns	
$T_{DOHZ}$	Data out to high impedance delay		20		ns	

**Figure 35:**  
SPI General Timing

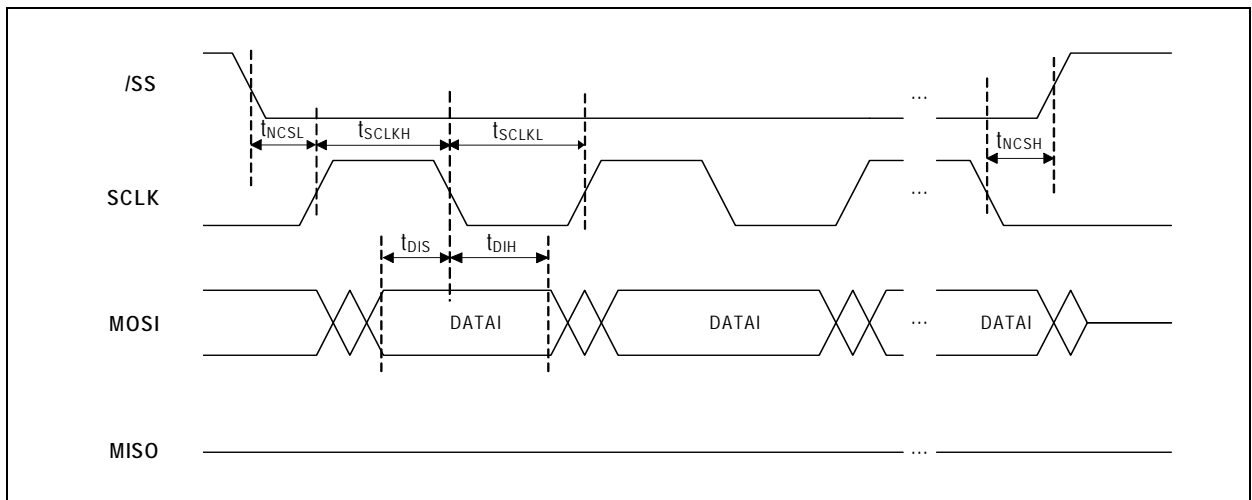

**Figure 36:**  
SPI Read Timing

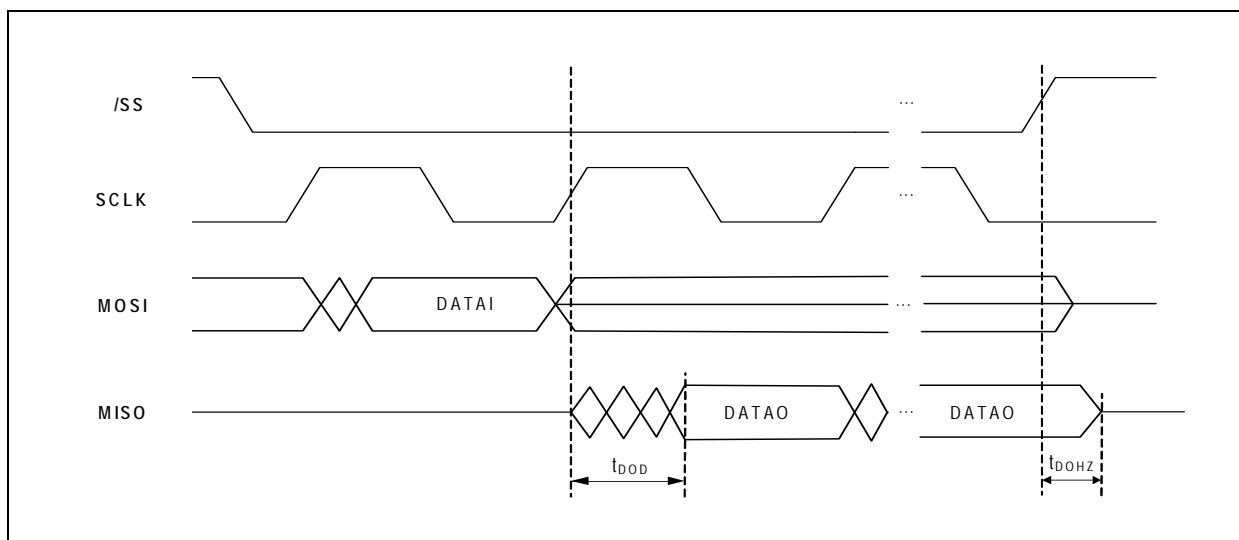

### Interrupt Interface

There are three interrupt registers implemented in the AS3911B (Main Interrupt Register and auxiliary Timer and NFC Interrupt Register and Error and Wake-Up Interrupt Register). Main Interrupt Register contains information about six interrupt sources, while two bits reference to interrupt sources detailed in Timer and NFC Interrupt Register and Error and Wake-Up Interrupt Register.

When an interrupt condition is met the source of interrupt bit is set in the Main Interrupt Register and the IRQ pin transitions to high.

The microcontroller then reads the Main Interrupt Register to distinguish between different interrupt sources. The interrupt registers 0x17, 0x18 and 0x19 are to be read in one attempt. After a particular Interrupt Register is read, its content is reset to 0. Exceptions to this rule are the bits pointing to auxiliary registers. These bits are only cleared when corresponding auxiliary register is read. IRQ pin transitions to low after the interrupt bit(s) which caused its transition to high has been read. Please note that there may be more than one interrupt bits set in case the microcontroller did not immediately read the interrupt registers after the IRQ signal was set and another event causing interrupt occurred. In that case the IRQ pin transitions to low after the last bit which caused interrupt is read.

In case an interrupt from a certain source is not required it can be disabled by setting corresponding bit in the Mask Interrupt registers. In case of masking a certain interrupt source the interrupt is not produced, but the source of interrupt bit is still set in interrupt registers.

Figure 37:  
IRQ Output

Name	Signal	Signal Level	Description
IRQ	Digital output	CMOS	Interrupt output pin

**FIFO Water Level and FIFO Status Registers**

The AS3911B contains a 96 byte FIFO. In case of transmitting the Control logic shifts the data, which was previously loaded by the external microcontroller to the Framing Block and further to the Transmitter. During reception, the demodulated data is stored in the FIFO and the external microcontroller can download received data once reception was terminated.

Transmit and receive capabilities of the AS3911B are not limited by the FIFO size due to a FIFO water level interrupt system. During transmission an interrupt is sent (IRQ due to FIFO water level in the [Main Interrupt Register](#)) when the content of data in the FIFO passes from (*water level + 1*) to *water level* and the complete transmit frame has not been loaded in the FIFO yet. The external microcontroller can now add more data in the FIFO. The same stands for the reception: when the number of received bytes passes from (*water level - 1*) to *water level* an interrupt is sent to inform the external controller that data has to be downloaded from FIFO in order not to lose receive data due to FIFO overflow.

During transmission water level IRQ is additionally set in case all transmission bytes have not been written in FIFO yet and if number of bytes written into FIFO is lower than water level. In this case an IRQ is sent when number of bytes in FIFO drops below 4.

It is important to note that FIFO IRQ is not produced while SPI is active in FIFO load or read mode. Due to this the FIFO loading/reading rate has to be higher than Tx/Rx bit rate, once FIFO loading/reading is finished the /SS pin has to be pulled to V<sub>DD</sub> (logic remains in FIFO load/read mode as long as /SS remains low).

In case controller knows that the receive data frame is smaller than the FIFO size the water level interrupt does not have to be served. In such case the water level interrupt can be masked.

The external controller has to serve the FIFO faster than data is transmitted or received. Using SCLK frequency which is at least double than the actual receive or transmit bit rate is recommended.

There are two settings of the FIFO water level available for receive and transmit in the [IO Configuration Register 1](#).

After data reception is terminated the external microcontroller needs to know how much data is still stored in the FIFO: This information is available in the [FIFO Status Register 1](#) and [FIFO Status Register 2](#) which displays number of bytes in the FIFO



which were not read out. [FIFO Status Register 1](#) can also be read while reception and transmission processes are active to get info about current number of bytes in FIFO. In that case user has to take in account that Rx/Tx process is going on and that the number of data bytes in FIFO may have already changed by the time the reading of register is finished.

The [FIFO Status Register 2](#) additionally contains two bits which indicate that the FIFO was not correctly served during reception or transmission process (FIFO overflow and FIFO underflow).

FIFO overflow is set when too much data is written in FIFO. In case this bit is set during reception the external controller did not react on time on water level IRQ and more than 96 bytes were written in the FIFO. The received data is of course corrupted in such a case. During transmission this means that controller has written more data than FIFO size. The data to be transmitted was corrupted.

FIFO underflow is set when data was read from empty FIFO. In case this bit is set during reception the external controller read more data than was actually received. During transmission this means that controller has failed to provide the quantity of data defined in number of transmitted bytes registers on time.

### ***Pin MCU\_CLK***

Pin MCU\_CLK may be used as clock source for the external microcontroller. Depending on the operation mode either a low frequency clock (32 kHz) from the RC oscillator or the clock signal derived from crystal oscillator is available on pin MCU\_CLK. The MCU\_CLK output pin is controlled by bits *out\_c1*, *out\_c10* and *If\_clk\_off* in the [IO Configuration Register 1](#). Bits *out\_c1* enable the use of pin MCU\_CLK as clock source and define the division for the case the crystal oscillator is running (13.56 MHz, 6.78 MHz and 3.39 MHz are available). Bit *If\_clk\_off* controls the use of low frequency clock (32 kHz) in case the crystal oscillator is not running. By default configuration, which is defined at power-up, the 3.39 MHz clock is selected and the low frequency clock is enabled.

In case the Transparent mode (see [Stream Mode and Transparent Mode](#)) is used the use of MCU\_CLK is mandatory since clock which is synchronous to the field carrier frequency is needed to implement receive and transmit framing in the external controller. The use of MCU\_CLK is recommended also for the case where the internal framing is used. Using MCU\_CLK as the microcontroller clock source generates noise which is synchronous to the reader carrier frequency and is therefore filtered out by the receiver while using some other incoherent clock source may produce noise which perturbs the reception. Use of MCU\_CLK is also better for EMC compliance.

## Direct Commands

**Figure 38:**  
List of Direct Commands

Command Code (hex)	Command	Comments	Command Chaining	Interrupt after Termination	Operation Mode <sup>(1)</sup>
C1	Set Default	Puts the AS3911B in default state (same as after power-up)	No	No	all
C2, C3	Clear	Stops all activities and clears FIFO	Yes	No	en
C4	Transmit With CRC	Starts a transmit sequence using automatic CRC generation	Yes	No	en, tx_en
C5	Transmit Without CRC	Starts a transmit sequence without automatic CRC generation	Yes	No	en, tx_en
C6	Transmit REQA	Transmits REQA command (ISO14443A mode only)	Yes	No	en, tx_en
C7	Transmit WUPA	Transmits WUPA command (ISO14443A mode only)	Yes	No	en, tx_en
C8	NFC Initial Field ON	Performs Initial RF Collision avoidance and switch on the field	Yes	Yes	en <sup>(2)</sup>
C9	NFC Response Field ON	Performs Response RF Collision avoidance and switch on the field	Yes	Yes	en <sup>(2)</sup>
CA	NFC Response Field ON with n=0	Performs Response RF Collision avoidance with n=0 and switch on the field	Yes	Yes	en <sup>(2)</sup>
CB	Go to Normal NFC Mode	Accepted in NFCIP-1 active communication bit rate detection mode	Yes	No	
CC	Analog Preset	Presets Rx and Tx configuration based on state of <a href="#">Mode Definition Register</a> and <a href="#">Bit Rate Definition Register</a>	Yes	No	all
D0	Mask Receive Data	Receive after this command is ignored	Yes	No	en, rx_en

Command Code (hex)	Command	Comments	Command Chaining	Interrupt after Termination	Operation Mode <sup>(1)</sup>
D1	Unmask Receive Data	Receive data following this command is normally processed (this command has priority over internal Mask Receive Timer)	Yes	No	en, rx_en
D2	see note (3)	Not used			
D3	Measure Amplitude	Amplitude of signal present on RFI inputs is measured, result is stored in <a href="#">A/D Converter Output Register</a>	No	Yes	en
D4	Squelch	Performs gain reduction based on the current noise level	No	No	en, rx_en
D5	Reset Rx Gain	Clears the current Squelch setting and loads the manual gain reduction from <a href="#">Receiver Configuration Register 4</a>	No	No	en <sup>(4)</sup>
D6	Adjust Regulators	Adjusts supply regulators according to the current supply voltage level	No	Yes	en <sup>(5)</sup>
D7	Calibrate Modulation Depth	Starts sequence which activates the Tx, measures the modulation depth and adapts it to comply with the specified modulation depth	No	Yes	en
D8	Calibrate Antenna	Starts the sequence to adjust parallel capacitances connected to TRIMx pins so that the antenna LC tank is in resonance	No	Yes	en
D9	Measure Phase	Measurement of phase difference between the signal on RFO and RFI	No	Yes	en
DA	Clear RSSI	Clears RSSI bits and restarts the measurement	Yes	No	en
DC	Transparent Mode	Enter in Transparent mode	No	No	en
DD	Calibrate Capacitive Sensor	Calibrates capacitive sensor	No	Yes	see note (6)

Command Code (hex)	Command	Comments	Command Chaining	Interrupt after Termination	Operation Mode <sup>(1)</sup>
DE	Measure Capacitance	Performs Capacitor Sensor Measurement	No	Yes	see note (7)
DF	Measure Power Supply		No	Yes	en
E0	Start General Purpose Timer		Yes	No	en
E1	Start Wake-Up Timer		Yes	No	all except wu
E2	Start Mask-Receive Timer		Yes	No	see note (8)
E3	Start No-Response Timer		Yes	No	en, rx_en
FC	Test Access	Enable /W to test registers	Yes	No	all
Other Fx		Reserved for test			
Other codes		Not used			

**Note(s) and/or Footnote(s):**

1. The 'Operation Mode' column in the above table defines which [Operation Control Register](#) bits have to be set in order to accept a particular command.
2. After termination of this command **I\_cat** or **I\_cac** IRQ is sent.
3. Was AD Convert in the AS3910.
4. Called Clear Squelch in the AS3910.
5. This command is not accepted in case the external definition of the regulated voltage is selected in the [Regulator Voltage Control Register](#) (bit **reg\_s** is set to high).
6. Accepted in all modes in case **cs\_mcal=0** ([Capacitive Sensor Control Register](#)), it is recommended to execute this command in Power-down mode.
7. Accepted in all modes, it is recommended to execute this command in Power-down mode.
8. Accepted only in the Initial NFC Active Target Communication Mode.
9. Called Check Antenna Resonance in the AS3910.
10. Called Measure RF in the AS3910.

### **Set Default**

This direct command puts the AS3911B in the same state as power-up initialization. All registers are initialized to the default state. The only exception are [IO Configuration Register 1](#), [IO Configuration Register 2](#) and [Operation Control Register](#) which are not affected by **Set Default** command and are only set to default state at power-up. Please note that results of different calibration and adjust commands are also lost.

This direct command is accepted in all operating modes. In case this command is sent while *en* (bit 7 of the [Operation Control Register](#)) is not set FIFO and FIFO Status Registers are *not* cleared.

Direct command chaining is not allowed since this command clears all registers.

IRQ due to termination of direct command is not produced.

### **Clear**

This direct command stops all current activities (transmission or reception), clears FIFO, clears FIFO Status Registers and stops all timers except Wake-up timer (in case bit *nrt\_emv* in the [General Purpose and No-Response Timer Control Register](#) is set to one, the No-Response Timer is not stopped). It also clears collision and interrupt registers. This command has to be sent first in a sequence preparing a transmission before writing data to be transmitted in FIFO (except in case of direct commands [Transmit REQA](#) and [Transmit WUPA](#)).

This command is accepted in case *en* (bit 7 of the [Operation Control Register](#)) is set and Xtal oscillator frequency is stable.

Direct command chaining is possible.

IRQ due to termination of direct command is not produced.

### **Transmit Commands**

All Transmit commands ([Transmit With CRC](#), [Transmit Without CRC](#), [Transmit REQA](#) and [Transmit WUPA](#)) are only accepted in case the Transmitter is enabled (bit *tx\_en* is set).

Before sending commands [Transmit With CRC](#) and [Transmit Without CRC](#) direct command [Clear](#) has to be sent, followed by definition of number of transmitted bytes and writing data to be transmitted in FIFO.

Direct commands [Transmit REQA](#) and [Transmit WUPA](#) are used to transmit ISO14443A commands REQA and WUPA respectively. Sending command [Clear](#) before these two commands is not necessary.

The number of valid bits in the last byte must be set to zero (*nbtx<2:0>* in the [Number of Transmitted Bytes Register 2](#)) prior to executing [Transmit REQA](#) or [Transmit WUPA](#).

Direct command chaining is possible.

IRQ due to termination of direct command is not produced.

**NFC Field ON Commands**

These commands are used to perform the RF collision avoidance and switch the field on in case no collision was detected. The Collision avoidance threshold defined in the [External Field Detector Threshold Register](#) is used to observe the RF\_IN inputs and to determine whether there is some other device, which is emitting the 13.56 MHz field, present close to the AS3911B antenna. In case collision is not detected the reader field is switched on automatically (bit *tx\_en* in the [Operation Control Register](#) is set) and an IRQ with *I\_cat* flag in [Timer and NFC Interrupt Register](#) is sent after minimum guard time defined by the NFCIP-1 standard to inform the controller that message transmission using a Transmit command can be initiated.

In case a presence of external field is detected an IRQ with *I\_cac* flag is sent. In such case a transmission cannot be performed, NFC Field ON command has to be repeated as long as collision is not detected any more.

Command [NFC Initial Field ON](#) performs Initial Collision Avoidance according to NFCIP-1 standard; number *n* is defined by bits *nfc\_n1* and *nfc\_n0* in [Auxiliary Definition Register](#).

Command [NFC Response Field ON](#) performs Response Collision Avoidance according to NFCIP-1 standard; number *n* is defined by bits *nfc\_n1* and *nfc\_n0* in [Auxiliary Definition Register](#).

Command [NFC Response Field ON with n=0](#), performs Response Collision Avoidance where *n* is 0.

Implemented active delay time is on lower NFCIP-1 specification limit, since the actual active delay time will also include detection of the field deactivation, controller processing delay and sending the NFC Field ON command.

**Figure 39:**  
Direct Command NFC Initial Field ON

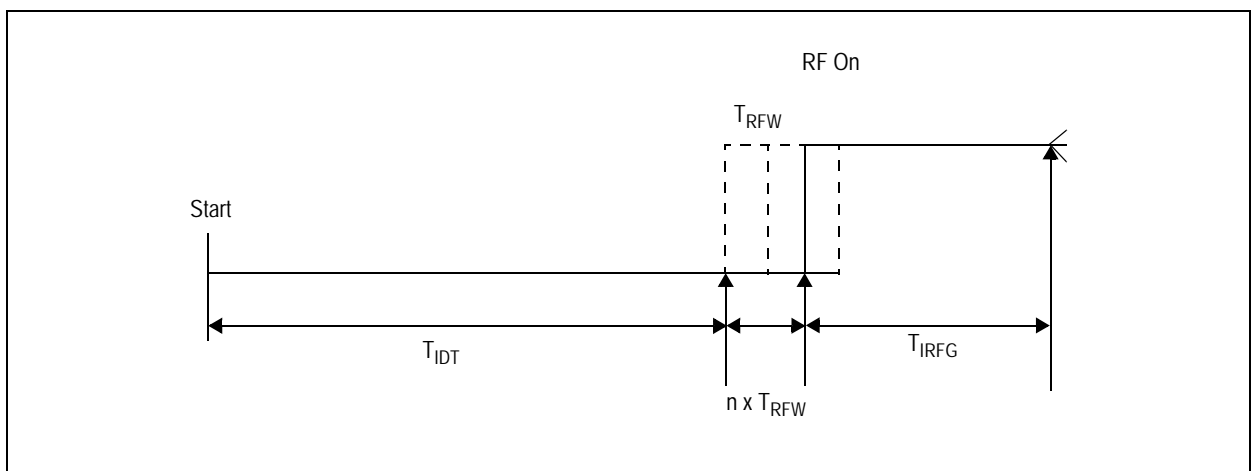

**Figure 40:**  
Direct Command NFC Response Field ON

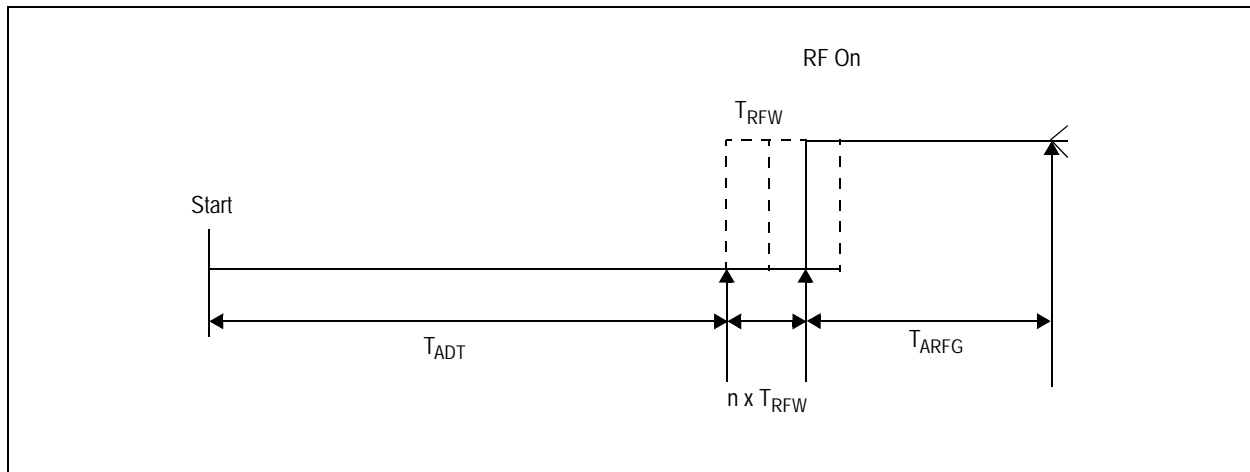

**Figure 41:**  
Timing Parameters of NFC Field ON Commands

Symbol	Parameter	Value	Unit	Note
$T_{IDT}$	Initial delay time	4096	/fc	NFC Initial Field ON
$T_{RWF}$	RF waiting time	512	/fc	
$T_{IRFG}$	Initial guard time	>5	ms	NFC Initial Field ON
$T_{ADT}$	Active delay time	768	/fc	NFC Response Field ON
$T_{ARFG}$	Active guard time	1024	/fc	NFC Response Field ON

This command is accepted in case *en* (bit 7 of the [Operation Control Register](#)) is set and Xtal oscillator frequency and amplitude are stable.

#### **Go to Normal NFC Mode**

This command is used to transition from NFC target bit rate detection mode to normal mode. Additionally it copies the content of the [NFCIP Bit Rate Detection Display Register](#) to the [Bit Rate Definition Register](#) and correctly sets the bit *tr\_am* in the [Auxiliary Definition Register](#).

#### **Analog Preset**

This command is used to preset Receiver and Transmitter configuration based on state of [Mode Definition Register](#) and [Bit Rate Definition Register](#). In case of Sub-carrier bit stream or BPSK bit stream mode, this command should not be used. The list of configuration bits that are preset is given in [Figure 42](#).

**Figure 42:**  
**Register Preset Bits**

Bit	Bit Name	Function
<b>Address 02<sub>h</sub>: Operation Control Register</b>		
5	rx_chn	<b>1:</b> one channel enabled → NFCIP-1 active communication (both initiator and target)
3	tx_en	<b>0:</b> disable TX operation → NFCIP-1 active communication (both initiator and target)
<b>Note:</b> In case of any target mode or NFCIP-1 initiator mode bit <b>tx_en</b> is set to 0 to disable transmitter in case it was enabled. In NFCIP-1 mode the switching on of the transmitter field is controlled by dedicated commands.		
<b>Address 05<sub>h</sub>: ISO14443A and NFC 106kb/s Settings Register</b>		
5	nfc_f0	<b>1:</b> Add SB (F0) and LEN byte during Tx and skip SB (F0) byte during TX → NFCIP-1 active communication (both initiator and target)
<b>Address 09<sub>h</sub>: Auxiliary Definition Register</b>		
5	tr_am	Tx Modulation type (depends on mode definition and Tx bit rate) <b>0:</b> OOK → ISO14443A, NFCIP-1 106 kb/s (both initiator and target), NFC Forum Type 1 Tag <b>1:</b> AM → ISO14443B, FeliCa, NFCIP-1 212 kb/s and 424 kb/s
4	en_fd	Enable External Field Detector with Peer Detection threshold <b>0:</b> All modes except NFCIP-1 active communication <b>1:</b> NFCIP-1 active communication (both initiator and target)
<b>Address 0A<sub>h</sub>: Receiver Configuration Register 1</b>		
7	ch_sel	<b>0:</b> Enable AM channel → NFCIP-1 active communication (both initiator and target)
6	amd_sel	AM demodulator select (depend on Rx bit rate) <b>0:</b> Peak detector → All Rx bit rates equal or below $f_c/16$ (848 kb/s) <b>1:</b> Mixer → All VHBR Rx bit rates ( $f_c/8$ and $f_c/4$ )
5	lp2	Low pass control (depends on mode definition and Rx bit rate) (see <a href="#">Figure 18</a> )
4	lp1	
3	lp0	
2	h200	First and third stage zero setting (depends on mode definition and Rx bit rate) (see <a href="#">Figure 18</a> )
1	h80	
0	z12k	
<b>Address 0C<sub>h</sub>: Receiver Configuration Register 3</b>		
1	lim	Clip output of 1 <sup>st</sup> and 2 <sup>nd</sup> stage <b>0:</b> All modes except NFCIP-1 active communication <b>1:</b> NFCIP-1 active communication (both initiator and target)
0	rg_nfc	Forces gain reduction in 2 <sup>nd</sup> and 3 <sup>rd</sup> gain stage <b>0:</b> All modes except NFCIP-1 active communication <b>1:</b> NFCIP-1 active communication (both initiator and target)



### **Mask Receive Data and Unmask Receive Data**

After the direct command [Mask Receive Data](#) the signal *rx\_on*, which enables the RSSI and AGC operation of the Receiver (see also [Receiver](#)) is forced to low, processing of the receiver output by the receive data framing block is disabled. This command is useful to mask receiver and receive framing from processing the data when there is actually no input and only a noise would be processed (for example in case where a transponder processing time after receiving a command from the reader is long). Masking of receive is also possible using Mask Receive Timer. Actual masking is a logical or of the two mask receive processes.

The direct command [Unmask Receive Data](#) is enabling normal processing of the received data (signal *rx\_on* is set high to enable the RSSI and AGC operation), the receive data framing block is enabled. A common use of this command is to enable again the receiver operation after it was masked by the command [Mask Receive Data](#). In case *Mask Receive Timer* is running while command [Unmask Receive Data](#) is received, reception is enabled, *Mask Receive Timer* is reset.

The commands [Mask Receive Data](#) and [Unmask Receive Data](#) are only accepted when the Receiver is enabled (bit *rx\_en* is set).

Direct command chaining is possible.

IRQ due to termination of direct command is not produced.

### **Measure Amplitude**

This command measures the amplitude on the RFI inputs and stores result in the [A/D Converter Output Register](#).

When this command is executed the Transmitter and Amplitude Detector are enabled, the output of the Amplitude Detector is multiplexed to the A/D Converter input (the A/D Converter is in absolute mode). The Amplitude Detector conversion gain is  $0.6 V_{INPP} / V_{OUT}$ . One LSB of the A/D converter output represents  $13.02 \text{ mV}_{pp}$  on the RFI inputs. A  $3 V_{pp}$  signal, which is maximum allowed level on each of the two RFI inputs, results in 1.8 V output DC voltage and would produce a value of 1110 0110b on the A/D converter output.

Duration time: 25  $\mu\text{s}$  max.

This command is accepted in case *en* (bit 7 of the [Operation Control Register](#)) is set and Xtal oscillator frequency is stable.

Direct command chaining is not possible.

IRQ due to termination of direct command is produced after command execution is terminated.

### **Squelch**

This direct command is intended to avoid demodulation problems of transponders which produce a lot of noise during data processing. It can also be used in a noisy environment. The operation of this command is explained in [Squelch](#).

Duration time: 500  $\mu$ s max.

This command is only accepted when the Transmitter and the Receiver are operating. Command is actually executed only in case signal *rx\_on* is low.

Direct command chaining is not possible.

IRQ due to termination of direct command is not produced.

### **Reset Rx Gain**

This command initializes the AGC, Squelch and RSSI block. Sending this command stops a squelch process in case it is going on, clears the current Squelch setting and loads the manual gain reduction from [Receiver Configuration Register 4](#).

This command is accepted in case *en* (bit 7 of the [Operation Control Register](#)) is set and Xtal oscillator frequency is stable.

Direct command chaining is possible.

IRQ due to termination of direct command is not produced.

### **Adjust Regulators**

When this command is sent the power supply level of  $V_{DD}$  is measured in maximum load conditions and the regulated voltage reference is set 250 mV below this measured level to assure maximum possible stable regulated supply (see [Power Supply System](#)). Using this command increases the system PSSR.

At the beginning of execution of this command, both the receiver and transmitter are switched on to have the maximum current consumption, the regulators are set to the maximum regulated voltage (5.1 V in case of 5 V supply and 3.4 V in case of 3.3 V supply mode). After 300  $\mu$ s  $V_{SP\_RF}$  is compared to  $V_{DD}$ , in case  $V_{SP\_RF}$  is not at least 250 mV lower the regulator setting is reduced for one step (120 mV in case of 5 V supply and 100 mV in case of 3.3 V supply mode) and measurement is done after next 300  $\mu$ s. Procedure is repeated until  $V_{SP\_RF}$  drops at least 250 mV below  $V_{DD}$  or until minimum regulated voltage (3.9 V in case of 5 V supply and 2.4 V in case of 3.3 V supply mode) is reached.

Duration time: 5 ms max.

This command is accepted in case *en* (bit 7 of the [Operation Control Register](#)) is set and Xtal oscillator frequency is stable.

This command is not accepted in case the external definition of the regulated voltage is selected in the [Regulator Voltage Control Register](#) (bit *reg\_s* is set to H)

Direct command chaining is not possible.

IRQ due to termination of direct command is produced after command execution is terminated.

**Calibrate Modulation Depth**

Starts a patent pending sequence, which activates the transmission, measures the modulation depth and adapts it to comply with the modulation depth specified in the [AM Modulation Depth Control Register](#). When calibration procedure is finished result is displayed in the [AM Modulation Depth Display Register](#). Please refer to [AM Modulation Depth: Definition and Calibration](#) for details about setting the AM modulation depth and running this command.

Duration time: 275  $\mu$ s max.

This command is accepted in case *en* (bit 7 of the [Operation Control Register](#)) is set and Xtal oscillator frequency is stable.

Direct command chaining is not possible.

IRQ due to termination of direct command is produced after command execution is terminated.

**Calibrate Antenna**

Sending this command starts a sequence which adjusts the parallel capacitances connected to TRIMx pins so that the antenna LC tank is in resonance. See [Antenna Tuning](#) for details.

Duration time: 250  $\mu$ s max.

This command is accepted in case *en* (bit 7 of the [Operation Control Register](#)) is set and Xtal oscillator frequency is stable.

**Measure Phase**

This command measures the phase difference between the signals on the RFO outputs and the signals on the RFI inputs and stores the result in the [A/D Converter Output Register](#).

During execution of the direct command [Measure Phase](#) the Transmitter and Phase Detector are enabled, the Phase Detector output is multiplexed on the input of A/D converter, which is set in relative mode. Since the A/D converter range is from 1/6 VSP\_A to 5/6 VSP\_A the actual phase detector range is from 30° to 150°. Values below 30° result in FF<sub>h</sub> while values above 150° result in 00<sub>h</sub>. 1 LSB of the A/D conversion output represents 0.13% of carrier frequency period (0.468°). The result of A/D conversion is in case of 90° phase shift in the middle of range (1000 0000b or 0111 1111b). Value higher than 1000 0000b means that phase detector output voltage is higher than VSP\_A/2, which corresponds to case with phase shift lower than 90°. In the opposite case, when the phase shift is higher than 90°, the result of A/D conversion is lower than 0111 1111b. For example, the phase difference of 135° depicted in [Figure 21](#) results in 0.75 VSP\_A, result stored in A/D converter is 31<sub>d</sub> (1F<sub>h</sub>).

The phase measurement result can be calculating using the following formulas:

$$0 \leq \phi \leq 30^\circ : result[dec] = 255$$

$$30 < \phi < 150^\circ : angle\_degrees = 30.0 + ((255.0 - u\_angle) / 255.0) * 120.0$$

$$150 \geq \phi \geq 180^\circ : result[dec] = 0$$

Duration time: 25  $\mu$ s max.

This command is accepted in case *en* (bit 7 of the [Operation Control Register](#)) is set and Xtal oscillator frequency is stable.

Direct command chaining is not possible.

IRQ due to termination of direct command is produced after command execution is terminated.

### **Clear RSSI**

The Receiver automatically clears the RSSI bits in the *Receiver State Display Register* and starts to measure the RSSI of the received signal when the signal *rx\_on* is asserted. Since the RSSI bits store peak value (peak-hold type) eventual variation of the receiver input signal will not be followed (this may happen in case of long message or test procedure). The direct command [Clear RSSI](#) clears the RSSI bits in the *Receiver State Display Register*, the RSSI measurement is restarted (in case of course *rx\_on* is still high).

This command is accepted in case *en* (bit 7 of the [Operation Control Register](#)) is set and Xtal oscillator frequency is stable.

Direct command chaining is possible.

IRQ due to termination of direct command is not produced.

### **Transparent Mode**

Enter in the Transparent mode. The Transparent mode is entered on the rising edge of signal */SS* and is maintained as long as signal */SS* is kept high. See [Transparent Mode](#) for more details.

This command is accepted in case *en* (bit 7 of the [Operation Control Register](#)) is set and Xtal oscillator frequency is stable.

### **Calibrate Capacitive Sensor**

This command calibrates the Capacitive Sensor. See [Capacitive Sensor](#) for more details.

Duration time: 3 ms max.

This command is executed in case capacitive sensor automatic calibration mode is set (all bits *cs\_mcal* in the [Capacitive Sensor Control Register](#) are set to 0). In order to avoid interference with Xtal oscillator and reader magnetic field it strongly recommended to use this command in Power-down mode only.

Direct command chaining is not possible.

IRQ due to termination of direct command is produced after command execution is terminated.

### **Measure Capacitance**

This command performs the capacitance measurement. See [Capacitive Sensor](#) for more details.

Duration time: 250  $\mu$ s max.

In order to avoid interference with Xtal oscillator and reader magnetic field it strongly recommended to use this command in Power-down mode only.

Direct command chaining is not possible.

IRQ due to termination of direct command is produced after command execution is terminated.

### **Measure Power Supply**

This command performs the power supply measurement. Configuration bits *mpsv1* and *mpsv0* of the [Regulator Voltage Control Register](#) define which power supply is measured ( $V_{DD}$ , VSP\_A, VSP\_D and VSP\_RF can be measured). Result of measurement is stored in the [A/D Converter Output Register](#). During the measurement the selected supply input is connected to a 1/3 resistive divider output of which is multiplexed to A/D converter in absolute mode. Due to 1/3 division one LSB represents 23.438 mV.

Duration time: 25  $\mu$ s max.

This command is accepted in case *en* (bit 7 of the [Operation Control Register](#)) is set and Xtal oscillator frequency is stable.

Direct command chaining is not possible.

IRQ due to termination of direct command is produced after command execution is terminated.

### **Start Timers**

See [Timers](#).

### **Test Access**

The AS3911B does not contain any dedicated test pins. A direct command Test Access is used to enable RW access of test registers and entry in different test modes. Pins CSI and CSO are used as test pins.

### **Test Mode Entry and Access to Test Registers**

Test registers are not part of normal SPI register address space. After sending a direct command Test Access, test registers can be accessed using normal Read/Write Register SPI command. Access to test register is possible in a chained command sequence where first command Test Access is sent, followed by read/write access to test registers using auto increment feature. After SPI interface reset (SS toggle) the content of test registers is kept. Test registers are set to default state at power-up and by sending commands Set Default and Clear Test Registers.

**Figure 43:**  
Analog Test and Observation Register

Test Address 01 <sub>h</sub> : Analog Test and Observation Register				Type: RW
Bit	Name	Default	Function	Comments
7	tana_7	0	Do not change	
6	tana_6	0	Do not change	
5	tana_5	0	Do not change	
4			Not used	
3	tana_3	0	See <a href="#">Figure 44</a>	These test modes are also intended for observation in normal mode. Several modes of this register are also available when <i>analog test mode</i> is not set.
2	tana_2	0		
1	tana_1	0		
0	tana_0	0		

**Note(s) and/or Footnote(s):**

1. Default setting is set at power-up and after commands [Set Default](#) and Clear Test Registers

**Figure 44:**  
Test Access Register - Tana Signal Selection Of CSI and CSO Pins

Tana_				Pin CSI		Pin CSO		
3	2	1	0	Pin Type	Functionality	Pin Type	Functionality	Comment
0	0	0	1	AO	Analog output of AM channel (before digitizer)	DO	Digital output of AM channel (after digitizer)	Normal operation
0	0	1	0	AO	Analog output of PM channel (before digitizer)	DO	Digital output of PM channel (after digitizer)	Normal operation
0	0	1	1	AO	Analog output of AM channel (before digitizer)	AO	Analog output of PM channel (before digitizer)	Normal operation
0	1	0	0	DO	Digital output of AM channel (after digitizer)	DO	Digital output of PM channel (after digitizer)	Normal operation
0	1	0	1	AO	Analog signal after first stage	AO	Analog signal after second stage	Normal operation PM channel if enabled, AM if PM is not enabled

Tana_				Pin CSI		Pin CSO		
3	2	1	0	Pin Type	Functionality	Pin Type	Functionality	Comment
1	0	0	1	DO	Channel selection from logic	DO	Collision avoidance detector output	Collision avoidance detectors are enabled
1	0	1	0	DO	Digital TX modulation signal	DO	Select PM	Analog part of channel selection

## Registers

The 6-bit register addresses below are defined in the hexadecimal notation. The possible address range is from 00<sub>h</sub> to 3F<sub>h</sub>.

There are two types of registers implemented in the AS3911B: configuration registers and display registers. The configuration registers are used to configure the AS3911B. They can be written and read through the SPI (RW). The display registers are read only (RO); they contain information about the AS3911B internal state.

Registers are set to their default state at power-up and after sending direct command [Set Default](#). The only exceptions are the [IO Configuration Register 1](#) and the [IO Configuration Register 2](#) which are only set to default state at power-up. Configuration bits of these two registries are related to hardware configuration which is in most cases not going to change during the operation.

**Figure 45:**  
Register Description

Address[hex]	Content	Comment	Type
<b>IO Configuration Registers</b>			
00	<a href="#">IO Configuration Register 1</a>	Set to default state only at power-up	RW
01	<a href="#">IO Configuration Register 2</a>		RW
<b>Operation Control and Mode Definition Registers</b>			
02	<a href="#">Operation Control Register</a>	Set to default state only at power-up	RW
03	<a href="#">Mode Definition Register</a>		
04	<a href="#">Bit Rate Definition Register</a>		RW

Address[hex]	Content	Comment	Type
<b>Configuration Registers</b>			
05	ISO14443A and NFC 106kb/s Settings Register		RW
06	ISO14443B Settings Register 1		RW
07	ISO14443B and FeliCa Settings Register		RW
08	Stream Mode Definition Register		RW
09	Auxiliary Definition Register		RW
0A	Receiver Configuration Register 1		RW
0B	Receiver Configuration Register 2		RW
0C	Receiver Configuration Register 3		RW
0D	Receiver Configuration Register 4		RW
<b>Timer Definition Registers</b>			
0E	Mask Receive Timer Register		RW
0F	No-Response Timer Register 1		RW
10	No-Response Timer Register 2		RW
11	General Purpose and No-Response Timer Control Register		RW
12	General Purpose Timer Register 1		RW
13	General Purpose Timer Register 2		RW
<b>Interrupt and Associated Reporting Registers</b>			
14	Mask Main Interrupt Register		RW
15	Mask Timer and NFC Interrupt Register		RW
16	Mask Error and Wake-Up Interrupt Register		RW
17	Main Interrupt Register		R
18	Timer and NFC Interrupt Register		R
19	Error and Wake-Up Interrupt Register		R
1A	FIFO Status Register 1		R
1B	FIFO Status Register 2		R
1C	Collision Display Register		R



Address[hex]	Content	Comment	Type
<b>Definition of Number of Transmitted Bytes</b>			
1D	Number of Transmitted Bytes Register 1		RW
1E	Number of Transmitted Bytes Register 2		RW
<b>NFCIP Bit Rate Detection Display Register</b>			
1F	NFCIP Bit Rate Detection Display Register		R
<b>A/D Converter Output Register</b>			
20	A/D Converter Output Register		R
<b>Antenna Calibration Registers</b>			
21	Antenna Calibration Control Register		RW
22	Antenna Calibration Target Register		RW
23	Antenna Calibration Display Register		R
<b>AM Modulation Depth and Antenna Driver Registers</b>			
24	AM Modulation Depth Control Register		RW
25	AM Modulation Depth Display Register		R
26	RFO AM Modulated Level Definition Register		RW
27	RFO Normal Level Definition Register		RW
<b>External Field Detector Threshold Registers</b>			
29	External Field Detector Threshold Register		RW
<b>Regulator Registers</b>			
2A	Regulator Voltage Control Register		RW
2B	Regulator and Timer Display Register		R
<b>Receiver State Display Registers</b>			
2C	RSSI Display Register		R
2D	Gain Reduction State Register		R
<b>Capacitive Sensor Registers</b>			
2E	Capacitive Sensor Control Register		RW
2F	Capacitive Sensor Display Register		R
<b>Auxiliary Display Register</b>			
30	Auxiliary Display Register		R

Address[hex]	Content	Comment	Type
<b>Wake-Up Registers</b>			
31	Wake-Up Timer Control Register		RW
32	Amplitude Measurement Configuration Register		RW
33	Amplitude Measurement Reference Register		RW
34	Amplitude Measurement Auto-Averaging Display Register		R
35	Amplitude Measurement Display Register		R
36	Phase Measurement Configuration Register		RW
37	Phase Measurement Reference Register		RW
38	Phase Measurement Auto-Averaging Display Register		R
39	Phase Measurement Display Register		R
3A	Capacitance Measurement Configuration Register		RW
3B	Capacitance Measurement Reference Register		RW
3C	Capacitance Measurement Auto-Averaging Display Register		R
3D	Capacitance Measurement Display Register		R
<b>IC Identity Register</b>			
3F	IC Identity Register		R

### IO Configuration Register 1

Figure 46:  
IO Configuration Register 1

Address 00 <sub>h</sub> : IO Configuration Register 1				Type: RW		
Bit	Name	Default	Function			Comments
7	single	0	1: Only one RFO driver will be used			Choose between single and differential driving of antenna
6	rfo2	0	0: RFO1, RF11 1: RFO2, RF12			Choose which output driver and which input will be used in case of single driving
5	fifo_lr	0	0: 64 1: 80			FIFO water level for receive
4	fifo_lt	0	0: 32 1: 16			FIFO water level for transmit
3	osc	1	0: 13.56 MHz Xtal 1: 27.12 MHz Xtal			Selector for crystal oscillator Use of VHBR is only possible with 27.12 MHz Xtal
2	out_cl1	0	out_cl1	out_cl0	MCU_CLK	Selection of clock frequency on MCU_CLK output in case Xtal oscillator is running. In case of "11" MCU_CLK output is permanently low.
			0	0	3.39 MHz	
1	out_cl0	0	0	1	6.78 MHz	
			1	0	13.56 MHz	
0	lf_clk_off	0	1	1	disabled	
			1: No LF clock on MCU_CLK			By default the 32 kHz LF clock is present on MCU_CLK output when Xtal oscillator is not running and the MCU_CLK output is not disabled.

**Note(s) and/or Footnote(s):**

1. Default setting is set at power-up only.

## IO Configuration Register 2

**Figure 47:**  
IO Configuration Register 2

Address 01 <sub>h</sub> : IO Configuration Register 2				Type: RW
Bit	Name	Default	Function	Comments
7	sup3 V	0	<b>0:</b> 5 V supply <b>1:</b> 3.3 V supply	5 V supply, range: 4.1 V to 5.5 V 3.3 V supply, range: 2.4 V to 3.6 V min. 3.0V for VHBR
6	vspd_off	0	<b>1:</b> Disable VSP_D regulator	Used for low cost applications. When this bit is set: At 3 V or 5 V supply VSP_D and VSP_A shall be shorted externally At 3.3 V applications VSP_D can alternatively be supplied from V <sub>DD</sub> in case VSP_A is not more than 300 mV lower than V <sub>DD</sub>
5			Not used	
4	miso_pd2	0	<b>1:</b> Pull-down on MISO, when /SS is low and MISO is not driven by the AS3911B	
3	miso_pd1	0	<b>1:</b> Pull-down on MISO when /SS is high	
2	io_18	0	<b>1:</b> Increase MISO driving level in case of 1.8 V V <sub>DD_IO</sub>	
1			Not used	
0	slow_up	0	<b>1:</b> Slow ramp at Tx on	≥ 10μs 10% to 90%, for B

**Note(s) and/or Footnote(s):**

1. Default setting is set at power-up only.

**Operation Control Register****Figure 48:**  
**Operation Control Register**

Address 02 <sub>h</sub> : Operation Control Register				Type: RW
Bit	Name	Default	Function	Comments
7	en	0	<b>1:</b> Enables oscillator and regulator (Ready mode)	
6	rx_en	0	<b>1:</b> Enables Rx operation	
5	rx_chn	0	<b>0:</b> Both, AM and PM, channels enabled <b>1:</b> One channel enabled	In case only one Rx channel is enabled, selection is done by the <a href="#">Receiver Configuration Register 1</a> bit <i>ch_sel</i>
4	rx_man	0	<b>0:</b> Automatic channel selection <b>1:</b> Manual channel selection	In case both Rx channels are enabled, it chooses the method of channel selection, manual selection is done by the <a href="#">Receiver Configuration Register 1</a> bit <i>ch_sel</i>
3	tx_en	0	<b>1:</b> Enables Tx operation	This bit is automatically set by NFC Field ON commands and reset in NFC active communication modes after transmission is finished
2	wu	0	<b>1:</b> Enables Wake-up mode	According to settings in <a href="#">Wake-Up Timer Control Register</a>
1			Not used	
0				

**Note(s) and/or Footnote(s):**

1. Default setting is set at power-up only.

**Mode Definition Register**

**Figure 49:**  
Mode Definition Register

Address 03 <sub>h</sub> : Mode Definition Register				Type: RW
Bit	Name	Default	Function	Comments
7	targ	0	<b>0:</b> Initiator <b>1:</b> Target	
6	om3	0	Refer to <a href="#">Initiator Operation Modes</a> and <a href="#">Target Operation Modes</a>	Selection of operation mode. Different for initiator and target mode.
5	om2	0		
4	om1	0		
3	om0	1		
2		0	Not used	
1		0		
0	nfc_ar	0		Automatic start of Response RF Collision Avoidance sequence

**Note(s) and/or Footnote(s):**

1. Default setting is set at power-up and after [Set Default](#) command.

**Figure 50:**  
Initiator Operation Modes

Initiator Operation Modes				
om3	om2	om1	om0	Comment
0	0	0	0	NFCIP-1 active communication
0	0	0	1	ISO14443A
0	0	1	0	ISO14443B
0	0	1	1	FeliCa
0	1	0	0	NFC Forum Type 1 Tag (Topaz)
1	1	1	0	Sub-carrier stream mode
1	1	1	1	BPSK stream mode
Other combinations				Not used

**Note(s) and/or Footnote(s):**

1. In case an operation mode which is not supported is selected, the Tx/Rx operation is disabled.

**Figure 51:**  
**Target Operation Modes**

Target Operation Modes				
om3	om2	om1	om0	Comment
0	0	0	0	NFCIP-1 active communication, bit rate detection mode
0	0	0	1	NFCIP-1 active communication, normal mode
Other combinations				Not used

**Note(s) and/or Footnote(s):**

1. In case an operation mode which is not supported is selected, the Tx/Rx operation is disabled.

### ***Bit Rate Definition Register***

**Figure 52:**  
**Bit Rate Definition Register**

Address 04 <sub>h</sub> : Bit Rate Definition Register				Type: RW
Bit	Name	Default	Function	Comments
7	tx_rate3	0	Refer to <a href="#">Bit Rate Coding</a>	Selects bit rate for Tx
6	tx_rate2	0		
5	tx_rate1	0		
4	tx_rate0	0		
3	rx_rate3	0		Selects bit rate for Rx in case selected protocol allows different bit rates for Rx and Tx
2	rx_rate2	0		
1	rx_rate1	0		
0	rx_rate0	0		

**Note(s) and/or Footnote(s):**

1. Default setting is set at power-up and after [Set Default](#) command.
2. Automatically loaded by direct command [Go to Normal NFC Mode](#).

**Figure 53:**  
Bit Rate Coding

Bit Rate Coding					
rate3	rate2	rate1	rate0	Bit rate [kbit/s]	Comment
0	0	0	0	fc/128 (~106)	
0	0	0	1	fc/64 (~212)	
0	0	1	0	fc/32 (~424)	
0	0	1	1	fc/16 (~848)	
0	1	0	0	fc/8 (~1695)	VHBR Tx is supported only for ISO14443B mode VHBR Rx is supported only for fc/8 and fc/4
0	1	0	1	fc/4 (~3390)	
0	1	1	0	fc/2 (~6780)	
Other combinations					Not used

**Note(s) and/or Footnote(s):**

1. In case a bit rate which is not supported is selected, the Tx/Rx operation is disabled.

**ISO14443A and NFC 106kb/s Settings Register**

**Figure 54:**  
ISO14443A and NFC 106kb/s Settings Register

Address 05 <sub>h</sub> : ISO14443A and NFC 106kb/s Settings Register				Type: RW
Bit	Name	Default	Function	Comments
7	no_tx_par	0	<b>1:</b> No parity bit is generated during Tx	Data stream is taken from FIFO, transmit has to be done using command <a href="#">Transmit Without CRC</a>
6	no_rx_par	0	<b>1:</b> Receive without parity and CRC	When set to 1 received bit stream is put in the FIFO, no parity and CRC detection is done
5	nfc_f0	0	<b>1:</b> Support of NFCIP-1 Transport Frame format	Add SB (F0) and LEN bytes during Tx and skip SB (F0) byte during Rx in NFC Active communication mode
4	p_len3	0	Refer to <a href="#">ISO14443A Modulation Pulse Width</a>	Modulation pulse width; defined in number of 13.56 MHz clock periods.
3	p_len2	0		
2	p_len1	0		
1	p_len0	0		



Address 05 <sub>h</sub> : ISO14443A and NFC 106kb/s Settings Register				Type: RW
Bit	Name	Default	Function	Comments
0	antcl	0	1: ISO14443 anticollision frame	Has to be set to 1 when ISO14443A bit oriented anticollision frame is sent

**Note(s) and/or Footnote(s):**

1. Default setting is set at power-up and after [Set Default](#) command.
2. no\_tx\_par and no\_rx\_par are used to send and receive custom frames like Mifare™ Classic frames.

**Figure 55:**  
ISO14443A Modulation Pulse Width

ISO14443A Modulation Pulse Width							
p_len3	p_len2	p_len1	p_len0	Pulse Width in Number of 1/fc for Different Bit Rates			
				fc/128	fc/64	fc/32	fc/16
0	1	1	1	42			
0	1	1	0	41	20		
0	1	0	1	40	21		
0	1	0	0	39	22	13	
0	0	1	1	38	21	12	8
0	0	1	0	37	20	11	7
0	0	0	1	36	19	10	6
0	0	0	0	35	18	9	5
1	1	1	1	34	17	8	4
1	1	1	0	33	16	7	3
1	1	0	1	32	15	6	2
1	1	0	0	31	14	5	
1	0	1	1	30	13		
1	0	1	0	29	12		
1	0	0	1	28			
1	0	0	0	27			

**ISO14443B Settings Register 1**
**Figure 56:**  
 ISO14443B Settings Register

Address 06 <sub>h</sub> : ISO14443B Settings Register 1							Type: RW
Bit	Name	Default	Function				Comments
7	egt2	0	egt2	egt1	egt0	Number of EGT	EGT time defined in number of etu
			0	0	0	0	
6	egt1	0	0	0	1	1	
			.	.	.	.	
5	egt0	0	1	1	0	6	
			1	1	1	6	
4	sof_0	0	0 → 10 etu, 1 → 11 etu				SOF, number of etu with logic 0 (10 or 11)
3	sof_1	0	0 → 2 etu, 1 → 3 etu				SOF, number of etu with logic 1 (2 or 3)
2	eof	0	0 → 10 etu, 1 → 11 etu				EOF, number of etu with logic 0 (10 or 11)
1	half		<b>1:</b> SOF 10.5, 2.5, EOF: 10.5				Sets SOF and EOF settings in middle of specification
0	rx_st_om		<b>1:</b> Start/stop bit omission for Rx				SOF= fixed to 10 low - 2 high, EOF not defined, put in FIFO last full byte <sup>(2)</sup>

**Note(s) and/or Footnote(s):**

1. Default setting is set at power-up and after [Set Default](#) command.
2. Start/stop bit omission for Tx can be implemented by using Stream mode.

**ISO14443B and FeliCa Settings Register****Figure 57:**  
ISO14443B and FeliCa Settings Register

Address 07 <sub>h</sub> : ISO14443B and FeliCa Settings Register				Type: RW
Bit	Name	Default	Function	Comments
7	tr1_1	0	Refer to <a href="#">Minimum TR1 Coding</a>	
6	tr1_0	0		
5	no_sof	0	<b>1:</b> No SOF PICC to PCD	According to ISO14443-3 chapter 7.10.3.3 Support of B'
4	no_eof	0	<b>1:</b> No EOF PICC to PCD	According to ISO14443-3 chapter 7.10.3.3
3	eof_12	0	<b>0:</b> PICC EOF 10 to 11 etu <b>1:</b> PICC EOF 10 to 12 etu	Support of B' <sup>(2)</sup>
2	phc_th	0	<b>1:</b> Increased tolerance of phase change detection	
1	f_p1	0	<b>00:</b> 48 <b>01:</b> 64 <b>10:</b> 80 <b>11:</b> 96	FeliCa preamble length (valid also for NFCIP-1 active communication bit rates 242 and 484 kb/s)
0	f_p0	0		

**Note(s) and/or Footnote(s):**

1. Default setting is set at power-up and after [Set Default](#) command.
2. Detection of EOF requires larger tolerance range for bit rates with only one sub-carrier frequency period per bit ( $f_c/16$  and higher). Due to this it is not possible to distinguish between EOF with 11 and 12 etu and setting this bit has no impact on EOF detection.

**Figure 58:**  
Minimum TR1 Codings

Minimum TR1 Coding			
tr1_1	tr1_0	Minimum TR1 for a PICC to PCD Bit Rate	
		$f_c / 128$	$> f_c / 128$
0	0	80 / fs	80 / fs
0	1	64 / fs	32 / fs
1	0	Not used	Not used
1	1	Not used	Not used

**Note(s) and/or Footnote(s):**

1. TR1 is defined in number of sub-carrier cycles, therefore at VHBR the absolute time becomes shorter.

**Stream Mode Definition Register**

**Figure 59:**  
Stream Mode Definition Register

Address 08 <sub>n</sub> : Stream Mode Definition Register				Type: RW		
Bit	Name	Default	Function			Comments
7		0				
6	scf1	0	Refer to <a href="#">Sub-Carrier Frequency Definition for Sub-Carrier and BPSK Stream Mode</a>			Sub-carrier frequency definition for Sub-carrier and BPSK stream mode
5	scf0	0				
4	scp1	0	scp1	scp0	number of pulses	Number of sub-carrier pulses in report period for Sub-carrier and BPSK stream mode
			0	0	1 (BPSK only)	
			0	1	2	
3	scp0	0	1	0	4	
			1	1	8	
2	stx2	0	Refer to <a href="#">Definition of Time Period for Stream Mode Tx Modulator Control</a>			Definition of time period for Tx modulator control (for Sub-carrier and BPSK stream mode)
1	stx1	0				
0	stx0					

**Note(s) and/or Footnote(s):**

1. Default setting is set at power-up and after [Set Default](#) command.

**Figure 60:**  
Sub-Carrier Frequency Definition for Sub-Carrier and BPSK Stream Mode

Sub-Carrier Frequency Definition for Sub-Carrier and BPSK Stream Mode			
scf1	scf0	Sub-Carrier Mode	BPSK Mode
0	0	fc/64 (212 kHz)	fc/16 (848 kHz)
0	1	fc/32 (424 kHz)	fc/8 (1695 kHz)
1	0	fc/16 (848 kHz)	fc/4 (3390 kHz)
1	1	fc/8 (1695 kHz)	Not used

**Figure 61:**  
**Definition of Time Period for Stream Mode Tx Modulator Control**

Definition of Time Period for Stream Mode Tx Modulator Control			
stx2	stx1	stx0	Time Period
0	0	0	fc/128 (106 kHz)
0	0	1	fc/64 (212 kHz)
0	1	0	fc/32 (424 kHz)
0	1	1	fc/16 (848 kHz)
1	0	0	fc/8 (1695 kHz)
1	0	1	fc/4 (3390 kHz)
1	1	0	fc/2(6780 kHz)
1	1	1	not used

## Auxiliary Definition Register

**Figure 62:**  
Auxiliary Definition Register

Address 09 <sub>n</sub> : Auxiliary Definition Register				Type: RW
Bit	Name	Default	Function	Comments
7	no_crc_rx	0	<b>1:</b> Receive without CRC	Valid for all protocols, for ISO14443A REQA, WUPA and anticollision receive without CRC is done automatically <sup>(2)</sup>
6	crc_2_fifo	0	<b>1:</b> Make CRC check, but put CRC bytes in FIFO and add them to number of receive bytes	Needed for EMV compliance
5	tr_am	0	<b>0:</b> OOK, <b>1:</b> AM	Set automatically by command <a href="#">Analog Preset</a> , can be modified by register write, has to be defined for transparent and bit stream mode Tx <sup>(3)</sup>
4	en_fd	0	<b>1:</b> Enable External Field Detector	External Field Detector with Peer Detection threshold is activated. Preset for NFCIP-1 active communication mode
3	ook_hr	0	<b>1:</b> Puts RFO driver in three-state during OOK modulation	Valid for all protocols using OOK modulation (also in Transparent mode)
2	rx_tol	1	<b>1:</b> BPSK fc/32: more tolerant BPSK decoder for bit rate fc/32, ISO14443A fc/128, NFCIP-1 fc/128: more tolerant processing of first byte	
1	nfc_n1	0		Definition on n for direct commands <a href="#">NFC Initial Field ON</a> and <a href="#">NFC Response Field ON</a>
0	nfc_n0	0		

**Note(s) and/or Footnote(s):**

- Default setting is set at power-up and after [Set Default](#) command.
- Receive without CRC is done automatically in case REQA and WUPA commands are sent using direct commands [Transmits REQA command](#) and [Transmits WUPA command](#), respectively, and in case anticollision is performed by setting bit antcl.
- Automatic preset of the **tr\_am**
- 0: OOK \* ISO14443A, NFCIP-1 106 kb/s, NFC Forum Type 1 Tag
- 1: AM \* ISO14443B, FeliCa, NFCIP-1 212 and 424 kb/s
- While en\_fd is set, and field detected in AP2P mode, this timer is reserved for internal use.

**Receiver Configuration Register 1****Figure 63:**  
**Receiver Configuration Register 1**

Address 0A <sub>n</sub> : Receiver Configuration Register 1 (Filter and Demodulator Settings)				Type: RW
Bit	Name	Default	Function	Comments
7	ch_sel	0	<b>0:</b> Enable AM channel <b>1:</b> Enable PM channel	In case only one Rx channel is enabled in the <a href="#">Operation Control Register</a> it defines which channel is enabled. In case both channels are enabled and manual channel selection is active, it defines which channel is used for receive framing.
6	amd_sel	0	<b>0:</b> Peak detector <b>1:</b> Mixer	AM demodulator type select, VHBR automatic preset to mixer
5	lp2	0	Low pass control ( <a href="#">Figure 16</a> )	For automatic and other recommended filter settings, refer to <a href="#">Figure 18</a> .
4	lp1	0		
3	lp0	0		
2	h200	0	First and third stage zero setting (see <a href="#">Figure 17</a> )	
1	h80	0		
0	z12k	0		

**Note(s) and/or Footnote(s):**

1. Default setting is set at power-up and after [Set Default](#) command.

## Receiver Configuration Register 2

**Figure 64:**  
Receiver Configuration Register 2

Address 0B <sub>h</sub> : Receiver Configuration Register 2				Type: RW
Bit	Name	Default	Function	Comments
7	rx_lp	0	<b>1:</b> Low power receiver operation	
6	lf_op	0	<b>0:</b> Differential LF operation <b>1:</b> LF input split (RFI1 to AM channel, RFI2 to PM channel)	
5	lf_en	0	<b>1:</b> LF signal on receiver input	
4	agc_en	1	<b>1:</b> AGC is enabled	
3	agc_m	1	<b>0:</b> AGC operates on first eight sub-carrier pulses <b>1:</b> AGC operates during complete receive period	
2	agc_alg	0	<b>0:</b> Algorithm with preset is used <b>1:</b> Algorithm with reset is used	Algorithm with preset is recommended for protocols with short SOF (like ISO14443A fc/128)
1	sqm_dyn	1	<b>1:</b> Automatic squelch activation after end of Tx	Activated 18.88 $\mu$ s after end of Tx, terminated with Mask Receive Timer expire
0	pmix_cl	0	<b>0:</b> RFO <b>1:</b> Internal signal	PM demodulator mixer clock source, in single mode internal signal is always used

**Note(s) and/or Footnote(s):**

1. Default setting is set at power-up and after [Set Default](#) command.



### Receiver Configuration Register 3

**Figure 65:**  
Receiver Configuration Register 3

Address 0C <sub>h</sub> : Receiver Configuration Register 3 (1 <sup>st</sup> stage gain settings)				Type: RW
Bit	Name	Default	Function	Comments
7	rg1_am2	1	Gain reduction/boost in first gain stage of AM channel.	<b>0:</b> Full gain <b>1-6:</b> Gain reduction 2.5 dB per step (15 dB total) <b>7:</b> Boost +5.5 dB
6	rg1_am1	1		
5	rg1_am0	0		
4	rg1_pm2	1	Gain reduction/boost in first gain stage of PM channel.	<b>0:</b> Full gain <b>1-6:</b> Gain reduction 2.5 dB per step (15 dB total) <b>7:</b> Boost +5.5 dB
3	rg1_pm1	1		
2	rg1_pm0	0		
1	lim	0	<b>1:</b> Clip output of 1 <sup>st</sup> and 2 <sup>nd</sup> stage	Signal clipped to 0.6 V, preset for NFCIP-1 active communication mode
0	rg_nfc	0	<b>1:</b> Forces gain reduction in 2 <sup>nd</sup> and 3 <sup>rd</sup> gain stage to -6 dB and maximum comparator window	Preset for NFCIP-1 active communication mode. After clearing this bit, receiver must be restarted.

**Note(s) and/or Footnote(s):**

1. Default setting is set at power-up and after [Set Default](#) command.

### Receiver Configuration Register 4

**Figure 66:**  
Receiver Configuration Register 4

Address 0D <sub>h</sub> : Receiver Configuration Register 4 (2 <sup>nd</sup> and 3 <sup>rd</sup> stage gain settings)				Type: RW
Bit	Name	Default	Function	Comments
7	rg2_am3	0	<b>AM channel:</b> Gain reduction in second and third stage and digitizer	Values from 0 <sub>h</sub> to A <sub>h</sub> are used. Other values are not used. Settings 1 <sub>h</sub> to 4 <sub>h</sub> reduce gain by increasing the digitizer window in 3dB steps, values from 5 <sub>h</sub> to A <sub>h</sub> additionally reduce the gain in 2 <sup>nd</sup> and 3 <sup>rd</sup> gain stage also in 3 dB steps.
6	rg2_am2	0		
5	rg2_am1	0		
4	rg2_am0	0		
3	rg2_pm3	0	<b>PM channel:</b> Gain reduction in second and third stage and digitizer	Values from 0 <sub>h</sub> to A <sub>h</sub> are used. Other values are not used. Settings 1 <sub>h</sub> to 4 <sub>h</sub> reduce gain by increasing the digitizer window in 3dB steps, values from 5 <sub>h</sub> to A <sub>h</sub> additionally reduce the gain in 2 <sup>nd</sup> and 3 <sup>rd</sup> gain stage also in 3 dB steps.
2	rg2_pm2	0		
1	rg2_pm1	0		
0	rg2_pm0	0		

**Note(s) and/or Footnote(s):**

1. Default setting is set at power-up and after [Set Default](#) command.
2. Sending of direct command [Reset Rx Gain](#) is necessary to load the value of this register into AGC, Squelch, and RSSI block.

**Mask Receive Timer Register****Figure 67:**  
Mask Receive Timer Register

Address 0E <sub>h</sub> : Mask Receive Timer Register				Type: RW
Bit	Name	Default	Function	Comments
7	mrt7	0	Defined in steps of 64/fc (4.72 μs). Range from 256/fc (~18.88 μs) to 16320/fc (~1.2 ms) Timeout = $mrt<7:0> * 64/fc$ Timeout ( $0 \leq mrt<7:0> \leq 4$ ) = $4 * 64/fc$ (18.88 μs) In NFCIP-1 bit rate detection mode one step is 512/fc (37.78 μs)	Defines time after end of Tx during which receiver output is masked (ignored). For the case of ISO14443A 106 kbit/s the Mask Receive Timer is defined according to PCD to PICC frame delay time definition, where mrt<7:0> define number of n/2 steps. Minimum mask receive time of 18.88 μs covers the transients in receiver after end of transmission.
6	mrt6	0		
5	mrt5	0		
4	mrt4	0		
3	mrt3	1		
2	mrt2	0		
1	mrt1	0		
0	mrt0	0		

**Note(s) and/or Footnote(s):**

1. Default setting is set at power-up and after [Set Default](#) command.
2. In NFCIP-1 bit rate detection mode, the clock of the Mask Receive Timer is additionally divided by eight (one count is 512/fc) to cover range up to ~9.6 ms.

**No-Response Timer Register 1****Figure 68:**  
No-Response Timer Register 1

Address 0F <sub>h</sub> : No-Response Timer Register 1				Type: RW
Bit	Name	Default	Function	Comments
7	nrt15	0	No-Response Timer definition MSB bits Defined in steps of 64/fc (4.72 μs). Range from 0 to 309 ms  In case bit <i>nrt_step</i> in <a href="#">General Purpose and No-Response Timer Control Register</a> is set the step is changed to 4096/fc	Defines timeout after end of Tx. In case this timeout expires without detecting a response a No-response interrupt is sent. In NFC mode the NO response timer is started only when external field is detected" with "In the NFCIP-1 active communication mode the No-Response Timer is automatically started when the transmitter is turned off after the message has been sent <b>All 0:</b> No-Response timer is not started. No-Response timer is reset and restarted with <a href="#">Start No-Response Timer</a> direct command.
6	nrt14	0		
5	nrt13	0		
4	nrt12	0		
3	nrt11	0		
2	nrt10	0		
1	nrt9	0		
0	nrt8	0		

**Note(s) and/or Footnote(s):**

1. Default setting is set at power-up and after [Set Default](#) command.

**No-Response Timer Register 2**

**Figure 69:**  
No-Response Timer Register 2

Address 10 <sub>h</sub> : No-Response Timer Register 2				Type: RW
Bit	Name	Default	Function	Comments
7	nrt7	0	No-Response Timer definition LSB bits	
6	nrt6	0		
5	nrt5	0		
4	nrt4	0		
3	nrt3	0		
2	nrt2	0		
1	nrt1	0		
0	nrt0	0		

**Note(s) and/or Footnote(s):**

1. Default setting is set at power-up and after [Set Default](#) command.

**General Purpose and No-Response Timer Control Register**

**Figure 70:**  
General Purpose and No-Response Timer Control Register

Address 11 <sub>h</sub> : General Purpose and No-Response Timer Control Register				Type: RW
Bit	Name	Default	Function	Comments
7	gptc2	0	Defines the timer trigger source. Refer to <a href="#">Timer Trigger Source</a> .	
6	gptc1	0		
5	gptc0	0		
4		0		
3		0		
2		0		

Address 11 <sub>h</sub> : General Purpose and No-Response Timer Control Register				Type: RW
Bit	Name	Default	Function	Comments
1	nrt_emv	0	<b>1</b> : EMV mode of No-Response timer	
0	nrt_step	0	<b>0</b> : 64/fc <b>1</b> : 4096/fc	Selects the No-Response Timer step.

**Note(s) and/or Footnote(s):**

1. Default setting is set at power-up and after [Set Default](#) command.

**Figure 71:**  
**Timer Trigger Source**

Timer Trigger Source			
gptc2	gptc1	gptc0	Trigger Source
0	0	0	No trigger source, start only with direct command <a href="#">Start General Purpose Timer</a> .
0	0	1	End of Rx (after EOF)
0	1	0	Start of Rx
0	1	1	End of Tx in NFC mode, when General Purpose Timer expires the field is switched off
1	0	0	Not used
1	0	1	
1	1	0	
1	1	1	

### General Purpose Timer Register 1

Figure 72:  
General Purpose Timer Register 1

Address 12 <sub>n</sub> : General Purpose Timer Register 1				Type: RW
Bit	Name	Default	Function	Comments
7	gpt15		General purpose timeout definition MSB bits Defined in steps of 8/fc (590 ns) Range from 590 ns to 38,7 ms	
6	gpt14			
5	gpt13			
4	gpt12			
3	gpt11			
2	gpt10			
1	gpt9			
0	gpt8			

**Note(s) and/or Footnote(s):**

1. Default setting is set at power-up and after [Set Default](#) command.

### General Purpose Timer Register 2

Figure 73:  
General Purpose Timer Register 2

Address 13 <sub>n</sub> : General Purpose Timer Register 2				Type: RW
Bit	Name	Default	Function	Comments
7	gpt7		General purpose timeout definition LSB bits Defined in steps of 8/fc (590 ns) Range from 590 ns to 38,7 ms	
6	gpt6			
5	gpt5			
4	gpt4			
3	gpt3			
2	gpt2			
1	gpt1			
0	gpt0			

**Note(s) and/or Footnote(s):**

1. Default setting is set at power-up and after [Set Default](#) command.

**Mask Main Interrupt Register****Figure 74:**  
Mask Main Interrupt Register

Address 14 <sub>h</sub> : Mask Main Interrupt Register				Type: RW
Bit	Name	Default	Function	Comments
7	M_osc	0	Mask IRQ when oscillator frequency is stable	
6	M_wl	0	Mask IRQ due to FIFO water level	
5	M_rxs	0	Mask IRQ due to start of receive	
4	M_rxe	0	Mask IRQ due to end of receive	
3	M_txe	0	Mask IRQ due to end of transmission	
2	M_col	0	Mask IRQ due to bit collision	
1		0	Not used	
0		0		

**Note(s) and/or Footnote(s):**

1. Default setting is set at power-up and after [Set Default](#) command.

**Mask Timer and NFC Interrupt Register****Figure 75:**  
Mask Timer and NFC Interrupt Register

Address 15 <sub>h</sub> : Mask Timer and NFC Interrupt Register				Type: RW
Bit	Name	Default	Function	Comments
7	M_dct	0	Mask IRQ due to termination of direct command	
6	M_nre	0	Mask IRQ due to No-Response Timer expire	
5	M_gpe	0	Mask IRQ due to general purpose timer expire	
4	M_eon	0	Mask IRQ due to detection of external field higher than Target activation level	
3	M_eof	0	Mask IRQ due to detection of external field drop below Target activation level	

Address 15 <sub>h</sub> : Mask Timer and NFC Interrupt Register				Type: RW
Bit	Name	Default	Function	Comments
2	M_cac	0	Mask IRQ due to detection of collision during RF Collision Avoidance	
1	M_cat	0	Mask IRQ after minimum guard time expire	
0	M_nfct	0	Mask IRQ when in target mode the initiator bit rate was recognized	

**Note(s) and/or Footnote(s):**

1. Default setting is set at power-up and after [Set Default](#) command.

**Mask Error and Wake-Up Interrupt Register**

**Figure 76:**  
Mask Error and Wake-Up Interrupt Register

Address 16 <sub>h</sub> : Mask Error and Wake-Up Interrupt Register				Type: RW
Bit	Name	Default	Function	Comments
7	M_crc	0	Mask IRQ due to CRC error	
6	M_par	0	Mask IRQ due to parity error	
5	M_err2	0	Mask IRQ due to soft framing error	
4	M_err1	0	Mask IRQ due to hard framing error	
3	M_wt	0	Mask IRQ due to wake-up interrupt	
2	M_wam	0	Mask Wake-up interrupt due to Amplitude Measurement	
1	M_wph	0	Mask Wake-up interrupt due to Phase Measurement.	
0	M_wcap	0	Mask Wake-up interrupt due to Capacitance Measurement	

**Note(s) and/or Footnote(s):**

1. Default setting is set at power-up and after [Set Default](#) command.



### Main Interrupt Register

**Figure 77:**  
Main Interrupt Register

Address 17 <sub>n</sub> : Main Interrupt Register				Type: R
Bit	Name	Default	Function	Comments
7	I_osc		IRQ when oscillator frequency is stable	Set after oscillator is started by setting <a href="#">Operation Control Register</a> bit <i>en</i> .
6	I_wl		IRQ due to FIFO water level	Set during receive, informing that FIFO is almost full and has to be read out. Set during transmit, informing that FIFO is almost empty and that additional data has to be sent.
5	I_rxs		IRQ due to start of receive	
4	I_rxe		IRQ due to end of receive	
3	I_txe		IRQ due to end of transmission	
2	I_col		IRQ due to bit collision	
1	I_tim		IRQ due to timer or NFC event	Details are in <a href="#">Timer and NFC Interrupt Register</a>
0	I_err		IRQ due to error and wake-up timer	Details are in <a href="#">Error and Wake-Up Interrupt Register</a>

**Note(s) and/or Footnote(s):**

1. At power-up and after [Set Default](#) command, content of this register is set to 0.
2. After [Main Interrupt Register](#) has been read, its content is set to 0, except for bits 1 and 0, which are set to 0 after corresponding interrupt register is read.

### Timer and NFC Interrupt Register

**Figure 78:**  
Timer and NFC Interrupt Register

Address 18 <sub>n</sub> : Timer and NFC Interrupt Register				Type: R
Bit	Name	Default	Function	Comments
7	I_dct		IRQ due to termination of direct command	
6	I_nre		IRQ due to No-Response Timer expire	
5	I_gpe		IRQ due to general purpose timer expire	
4	I_eon		IRQ due to detection of external field higher than Target activation level	
3	I_eof		IRQ due to detection of external field drop below Target activation level	
2	I_cac		IRQ due to detection of collision during RF Collision Avoidance	An external field was detected during RF Collision Avoidance
1	I_cat		IRQ after minimum guard time expire	An external field was not detected during RF Collision Avoidance, field was switched on, IRQ is sent after minimum guard time according to NFCIP-1
0	I_nfct		IRQ when in target mode the initiator bit rate was recognized	

**Note(s) and/or Footnote(s):**

1. At power-up and after [Set Default](#) command, content of this register is set to 0.
2. After [Timer and NFC Interrupt Register](#) has been read, its content is set to 0.

### Error and Wake-Up Interrupt Register

**Figure 79:**  
Error and Wake-Up Interrupt Register

Address 19 <sub>n</sub> : Error and Wake-Up Interrupt Register				Type: R
Bit	Name	Default	Function	Comments
7	I_crc		CRC error	
6	I_par		Parity error	
5	I_err2		Soft framing error	Framing error which does not result in corrupted Rx data
4	I_err1		Hard framing error	Framing error which results in corrupted Rx data
3	I_wt		Wake-up interrupt	Timeout after execution of <a href="#">Start Wake-Up Timer</a> command In case option with IRQ at every timeout is selected
2	I_wam		Wake-up interrupt due to Amplitude Measurement	Result of Amplitude Measurement was $\Delta am$ larger than reference
1	I_wph		Wake-up interrupt due to Phase Measurement.	Result of Phase Measurement was $\Delta pm$ larger than reference
0	I_wcap		Wake-up interrupt due to Capacitance Measurement	Result of Capacitance Measurement was $\Delta cm$ larger than reference

**Note(s) and/or Footnote(s):**

1. At power-up and after [Set Default](#) command, content of this register is set to 0
2. After [Error and Wake-Up Interrupt Register](#) has been read, its content is set to 0

### FIFO Status Register 1

**Figure 80:**  
FIFO Status Register 1

Address 1A <sub>h</sub> : FIFO Status Register 1				Type: R
Bit	Name	Default	Function	Comments
7				
6	fifo_b6		Number of bytes (binary coded) in the FIFO which were not read out	Valid range is from 0 (000 0000b) to 96 (110 0000b)
5	fifo_b5			
4	fifo_b4			
3	fifo_b3			
2	fifo_b2			
1	fifo_b1			
0	fifo_b0			

**Note(s) and/or Footnote(s):**

1. At power-up and after direct commands [Set Default](#) and [Clear](#), content of this register is set to 0.

## FIFO Status Register 2

**Figure 81:**  
FIFO Status Register 2

Address 1B <sub>h</sub> : FIFO Status Register 2				Type: R
Bit	Name	Default	Function	Comments
7				
6	fifo_unf		FIFO underflow	Set when more bytes than actual content of FIFO were read
5	fifo_ovr		FIFO overflow	
4	fifo_ncp		Last FIFO byte is not complete	
3	fifo_lb2		Number of bits in last FIFO byte in case it was not complete (fifo_npc=1)	In case of incomplete byte the LSB part is valid
2	fifo_lb1			
1	fifo_lb0			
0	np_lb		Parity bit is missing in last byte	This is a framing error

**Note(s) and/or Footnote(s):**

- At power-up and after direct commands [Set Default](#) and [Clear](#), content of this register is set to 0.
- If FIFO is empty, the value of register FIFO Status Register 1 (0x1A<sub>h</sub>) is 0x00, register bits **fifo\_ncp**, **fifo\_lb2**, **fifo\_lb1** and **fifo\_lb0** in register block 0x1B<sub>h</sub> are cleared. Correct procedure for FIFO read is to read both "FIFO Status Register 1 & 2" and then read FIFO. Second register values need to be saved in MCU, if non-complete bytes are in FIFO.

### Collision Display Register

**Figure 82:**  
Collision Display Register

Address 1C <sub>n</sub> : Collision Display Register (for ISO14443A and NFCIP-1bit rate fc/128 Rx)				Type: R
Bit	Name	Default	Function	Comments
7	c_byte3		Number of full bytes before the bit collision happened.	The <a href="#">Collision Display Register</a> range covers ISO14443A anticollision command. In case collision (or framing error which is interpreted as collision) happens in a longer message, the <a href="#">Collision Display Register</a> is not set.
6	c_byte2			
5	c_byte1			
4	c_byte0			
3	c_bit2		Number of bits before the collision in the byte where the collision happened	
2	c_bit1			
1	c_bit0			
0	c_pb		Collision in parity bit	

**Note(s) and/or Footnote(s):**

1. At power-up and after direct commands [Set Default](#) and [Clear](#), content of this register is set to 0.

### Number of Transmitted Bytes Register 1

**Figure 83:**  
Number of Transmitted Bytes Register 1

Address 1D <sub>h</sub> : Number of Transmitted Bytes Register 1				Type: RW
Bit	Name	Default	Function	Comments
7	ntx12	0	Number of full bytes to be transmitted in one command, MSB bits	Maximum supported number of bytes is 8191
6	ntx11	0		
5	ntx10	0		
4	ntx9	0		
3	ntx8	0		
2	ntx7	0		
1	ntx6	0		
0	ntx5	0		

**Note(s) and/or Footnote(s):**

1. Default setting is set at power-up and after [Set Default](#) command.

### Number of Transmitted Bytes Register 2

**Figure 84:**  
Number of Transmitted Bytes Register 2

Address 1E <sub>h</sub> : Number of Transmitted Bytes 2				Type: RW
Bit	Name	Default	Function	Comments
7	ntx4	0	Number of full bytes to be transmitted in one command, MSB bits	Maximum supported number of bytes is 8191
6	ntx3	0		
5	ntx2	0		
4	ntx1	0		
3	ntx0	0		
2	nbtx2		Number of bits in the split byte 000 means that there is no split byte (all bytes all complete)	Applicable for ISO14443A: <ul style="list-style-type: none"> <li>• Bit oriented anticollision frame in case last byte is split byte</li> <li>• Tx is done without parity bit generation</li> </ul>
1	nbtx1			
0	nbtx0			

**Note(s) and/or Footnote(s):**

1. Default setting is set at power-up and after [Set Default](#) command.
2. If anctl bit is set while card is in idle state and nbtx is not 000, then i\_par will be triggered during WUPA direct command is issued.

**NFCIP Bit Rate Detection Display Register**

**Figure 85:**  
NFCIP Bit Rate Detection Display Register

Address 1F <sub>h</sub> : NFCIP Bit Rate Detection Display Register				Type: R
Bit	Name	Default	Function	Comments
7	nfc_rate3		Refer to <a href="#">Bit Rate Coding</a>	This register stores result of automatic bit rate detection in the NFCIP-1 active communication bit rate detection mode
6	nfc_rate2			
5	nfc_rate1			
4	nfc_rate0			
3			Not used	
2				
1				
0				

**Note(s) and/or Footnote(s):**

1. At power-up and after [Set Default](#) command, content of this register is set to 0.

**A/D Converter Output Register**

**Figure 86:**  
A/D Converter Output Register

Address 20 <sub>h</sub> : A/D Converter Output Register				Type: R
Bit	Name	Default	Function	Comments
7	ad7		Displays result of last A/D conversion.	
6	ad6			
5	ad5			
4	ad4			
3	ad3			
2	ad2			
1	ad1			
0	ad0			

**Note(s) and/or Footnote(s):**

1. At power-up and after [Set Default](#) command, content of this register is set to 0.



**Antenna Calibration Control Register****Figure 87:**  
**Antenna Calibration Control Register**

Address 21 <sub>h</sub> : Antenna Calibration Control Register				Type: RW
Bit	Name	Default	Function	Comments
7	trim_s	0	<b>0:</b> LC trim switches are defined by result of <a href="#">Calibrate Antenna</a> command <b>1:</b> LC trim switches are defined by bits <i>tre_x</i> written in this register	Defines source of driving switches on TRIMx pins
6	tre_3	0	MSB	LC trim switches are defined by data written in this register in case trim_s=1. A bit set to 1 switch on transistor on TRIM1_x and TRIM2_x pin.
5	tre_2	0		
4	tre_1	0		
3	tre_0	0	LSB	
2				
1				
0				

**Note(s) and/or Footnote(s):**

1. Default setting is set at power-up and after [Set Default](#) command.

### Antenna Calibration Target Register

**Figure 88:**  
Antenna Calibration Target Register

Address 22 <sub>h</sub> : Antenna Calibration Target Register				Type: RW
Bit	Name	Default	Function	Comments
7	act7	1	Define target phase for <a href="#">Calibrate Antenna</a> direct command	
6	act6	0		
5	act5	0		
4	act4	0		
3	act3	0		
2	act2	0		
1	act1	0		
0	act0	0		

**Note(s) and/or Footnote(s):**

1. Default setting is set at power-up and after [Set Default](#) command.

### Antenna Calibration Display Register

**Figure 89:**  
Antenna Calibration Display Register

Address 23 <sub>h</sub> : Antenna Calibration Display Register				Type: R
Bit	Name	Default	Function	Comments
7	tri_3		MSB	This register stores result of <a href="#">Calibrate Antenna</a> command. LC trim switches are defined by data written in this register in case <i>trim_s</i> = 0. A bit set to 1 indicates that corresponding transistor on TRIM1_x and TRIM2_x pin is switched on.
6	tri_2			
5	tri_1			
4	tri_0		LSB	
3	tri_err		<b>1:</b> Antenna calibration error	Set when Calibrate antenna sequence was not able to adjust resonance
2			Not used	
1				
0				

**Note(s) and/or Footnote(s):**

1. At power-up and after [Set Default](#) command, content of this register is set to 0.

**AM Modulation Depth Control Register****Figure 90:**  
**AM Modulation Depth Control Register**

Address 24 <sub>n</sub> : AM Modulation Depth Control Register				Type: RW
Bit	Name	Default	Function	Comments
7	am_s	0	<b>0:</b> AM modulated level is defined by bits mod5 to mod0. Level is adjusted automatically by <a href="#">Calibrate Modulation Depth</a> command <b>1:</b> AM modulated level is defined by bits dram7 to dram0.	
6	mod5	0	MSB	See Application Notes for details about AM modulation level definition.
5	mod4	0		
4	mod3	0		
3	mod2	0		
2	mod1	0		
1	mod0	0	LSB	
0				

**Note(s) and/or Footnote(s):**

1. Default setting is set at power-up and after [Set Default](#) command.

**AM Modulation Depth Display Register**

**Figure 91:**  
AM Modulation Depth Display Register

Address 25 <sub>h</sub> : AM Modulation Depth Display Register				Type: R
Bit	Name	Default	Function	Comments
7	md_7		MSB	Displays result of <a href="#">Calibrate Modulation Depth</a> command. Antenna drivers are composed of 8 binary weighted segments. Bit <i>md_x</i> set to one indicates that this particular segment will be disabled during AM modulated state. In case of error all 1 value is set.
6	md_6			
5	md_5			
4	md_4			
3	md_3			
2	md_2			
1	md_1			
0	md_0		LSB	

**Note(s) and/or Footnote(s):**

1. At power-up and after [Set Default](#) command, content of this register is set to 0.

**RFO AM Modulated Level Definition Register**

**Figure 92:**  
RFO AM Modulated Level Definition Register

Address 26 <sub>h</sub> : RFO AM Modulated Level Definition Register				Type: RW
Bit	Name	Default	Function	Comments
7	dram7	0	MSB	Antenna drivers are composed of 8 binary weighted segments. Setting a bit dram to 1 will disable corresponding segment during AM modulated state in case <i>am_s</i> bit is set to 1.
6	dram6	0		
5	dram5	0		
4	dram4	0		
3	dram3	0		
2	dram2	0		
1	dram1	0		
0	dram0	0	LSB	

**Note(s) and/or Footnote(s):**

1. Default setting is set at power-up and after [Set Default](#) command.

**RFO Normal Level Definition Register****Figure 93:**  
RFO Normal Level Definition Register

Address 27 <sub>n</sub> : RFO Normal Level Definition Register				Type: RW
Bit	Name	Default	Function	Comments
7	droff7	0	2 Ohm	Antenna drivers are composed of 8 binary weighted segments. Setting a bit droff to 1 will disable corresponding segment during normal non-modulated operation. The TX drivers are made up of 8 segments. Binary weighted from 2 Ohm to 256Ohm. By setting register 0x27 to 0xc0 you disable the 2 Ohm and 4 Ohm segments.
6	droff6	0	4 Ohm	
5	droff5	0	8 Ohm	
4	droff4	0	16 Ohm	
3	droff3	0	32 Ohm	
2	droff2	0	64 Ohm	
1	droff1	0	128 Ohm	
0	droff0	0	256 Ohm	

**Note(s) and/or Footnote(s):**

1. Default setting is set at power-up and after [Set Default](#) command.

Applying value FFh to the register 27h will put the drivers in tristate.

**External Field Detector Threshold Register****Figure 94:**  
External Field Detector Threshold Register

Address 29 <sub>n</sub> : External Field Detector Threshold Register				Type: RW
Bit	Name	Default	Function	Comments
7			Not used	
6	trg_l2	0	Peer Detection Threshold MSB	Peer Detection Threshold. Refer to <a href="#">Peer Detection Threshold as Seen on RF11 Input</a> .
5	trg_l1	1		
4	trg_l0	1	Peer Detection Threshold LSB	
3	rfe_t3	0	Collision Avoidance Threshold MSB	Collision Avoidance Threshold. Refer to <a href="#">Collision Avoidance Threshold as Seen on RF11 Input</a> .
2	rfe_t2	0		
1	rfe_t1	1		
0	rfe_t0	1	Collision Avoidance Threshold LSB	

**Note(s) and/or Footnote(s):**

1. Default setting is set at power-up and after [Set Default](#) command.

**Figure 95:**  
Peer Detection Threshold as Seen on RF11 Input

Peer Detection Threshold as Seen on RF11 Input			
trg_l2	trg_l1	trg_l0	Target Peer Detection Threshold Voltage [ $mV_{pp}$ on RF11]
0	0	0	75
0	0	1	105
0	1	0	150
0	1	1	205
1	0	0	290
1	0	1	400
1	1	0	560
1	1	1	800

**Figure 96:**  
Collision Avoidance Threshold as Seen on RFI1 Input

Collision Avoidance Threshold as Seen on RFI1 Input				
rfe_3	rfe_2	rfe_1	rfe_0	Typical Collision Avoidance Threshold Voltage [ $mV_{pp}$ on RFI1]
0	0	0	0	75
0	0	0	1	105
0	0	1	0	150
0	0	1	1	205
0	1	0	0	290
0	1	0	1	400
0	1	1	0	560
0	1	1	1	800
1	0	0	0	25
1	0	0	1	33
1	0	1	0	47
1	0	1	1	64
1	1	0	0	90
1	1	0	1	125
1	1	1	0	175
1	1	1	1	250

### Regulator Voltage Control Register

**Figure 97:**  
Regulator Voltage Control Register

Address 2A <sub>h</sub> : Regulated Voltage Control Register				Type: RW
Bit	Name	Default	Function	Comments
7	reg_s	0	<b>0:</b> Regulated voltages are defined by result of <a href="#">Adjust Regulators</a> command <b>1:</b> Regulated voltages are defined by <i>rege_x</i> bits written in this register	Defines mode of regulator voltage setting.
6	rege_3	0	MSB	External definition of regulated voltage. Refer to <a href="#">Regulated Voltage</a> for definition. In 5 V mode VSP_D and VSP_A regulators are set to 3.4 V
5	rege_2	0		
4	rege_1	0		
3	rege_0	0	LSB	
2	mpsv1	0	<b>00:</b> V <sub>DD</sub> <b>01:</b> VSP_A <b>10:</b> VSP_D <b>11:</b> VSP_RF	Define source of direct command <a href="#">Measure Power Supply</a> .
1	mpsv0	0		
0				

**Note(s) and/or Footnote(s):**

1. Default setting is set at power-up and after [Set Default](#) command.



### Regulator and Timer Display Register

**Figure 98:**  
Regulator and Timer Display Register

Address 2B <sub>h</sub> : Regulator and Timer Display Register				Type: R
Bit	Name	Default	Function	Comments
7	reg_3		MSB	This register displays actual regulated voltage setting. Refer to <a href="#">Regulated Voltage</a> for definition.
6	reg_2			
5	reg_1			
4	reg_0		LSB	
3				
2	gpt_on		<b>1:</b> General purpose timer is running	
1	nrt_on		<b>1:</b> No-response timer is running	
0	mrt_on		<b>1:</b> Mask receive timer is running	

**Note(s) and/or Footnote(s):**

1. At power-up and after [Set Default](#) command, regulated voltage is set to maximum 3.4V.

**Figure 99:**  
Regulated Voltages

Regulated Voltage					
reg_3 rege_3	reg_2 rege_2	reg_1 rege_1	reg_0 rege_0	Typical Regulated Voltage [V]	
				5 V Mode	3.3 V Mode
1	1	1	1	5.1	3.4
1	1	1	0	4.98	3.3
1	1	0	1	4.86	3.2
1	1	0	0	4.74	3.1
1	0	1	1	4.62	3.0
1	0	1	0	4.50	2.9
1	0	0	1	4.38	2.8
1	0	0	0	4.26	2.7
0	1	1	1	4.14	2.6
0	1	1	0	4.02	2.5
0	1	0	1	3.90	2.4
other combinations				not used	

**RSSI Display Register****Figure 100:**  
RSSI Display Register

Address 2C <sub>h</sub> : RSSI Display Register				Type: R
Bit	Name	Default	Function	Comments
7	rss_i_am_3		MSB	Stores peak value of AM channel RSSI measurement. Automatically cleared at beginning of transponder message and with <a href="#">Clear RSSI</a> command.
6	rss_i_am_2			
5	rss_i_am_1			
4	rss_i_am_0		LSB	
3	rss_i_pm_3		MSB	Stores peak value of PM channel RSSI measurement. Automatically cleared at beginning of transponder message and with <a href="#">Clear RSSI</a> command.
2	rss_i_pm_2			
1	rss_i_pm_1			
0	rss_i_pm_0		LSB	

**Note(s) and/or Footnote(s):**

1. At power-up and after [Set Default](#) command, content of this register is set to 0.
2. Bit 0x30[7] indicates which RSSI value is use in the logic for internal use.

**Figure 101:**  
 RSSI Table

RSSI Table				
rss_i_3	rss_i_2	rss_i_1	rss_i_0	Typical Signal on RF11 [mV <sub>rms</sub> ]
0	0	0	0	≤20
0	0	0	1	>20
0	0	1	0	>27
0	0	1	1	>37
0	1	0	0	>52
0	1	0	1	>72
0	1	1	0	>99
0	1	1	1	>136
1	0	0	0	>190
1	0	0	1	>262
1	0	1	0	>357
1	0	1	1	>500
1	1	0	0	>686
1	1	0	1	>950
1	1	1	0	not used
1	1	1	1	

**Gain Reduction State Register****Figure 102:**  
**Gain Reduction State Register**

Address 2D <sub>h</sub> : Gain Reduction State Register				Type: R
Bit	Name	Default	Function	Comments
7	gs_am_3		MSB	Actual gain reduction of second stage of AM channel (including register gain reduction, squelch and AGC)
6	gs_am_2			
5	gs_am_1			
4	gs_am_0		LSB	
3	gs_pm_3		MSB	Actual gain reduction of second stage of PM channel (including register gain reduction, squelch and AGC)
2	gs_pm_2			
1	gs_pm_1			
0	gs_pm_0		LSB	

**Note(s) and/or Footnote(s):**

1. At power-up and after [Set Default](#) command, content of this register is set to 0.

### Capacitive Sensor Control Register

**Figure 103:**  
Capacitive Sensor Control Register

Address 2E <sub>n</sub> : Capacitive Sensor Control Register				Type: RW
Bit	Name	Default	Function	Comments
7	cs_mcal4	0	Manual calibration value All 0 value enables automatic calibration mode	Binary weighted, step 0.1 pF, max 3.1 pF
6	cs_mcal3	0		
5	cs_mcal2	0		
4	cs_mcal1	0		
3	cs_mcal0	0		
2	cs_g2	0	<b>000:</b> 2.8 V/pF <b>001:</b> 6.5 V/pF <b>010:</b> 1.1 V/pF <b>100:</b> 0.5 V/pF <b>110:</b> 0.35 V/pF <b>Other:</b> Not used	Capacitor sensor gain typical values
1	cs_g1	0		
0	cs_g0	0		

**Note(s) and/or Footnote(s):**

1. At power-up and after [Set Default](#) command, content of this register is set to 0.

**Capacitive Sensor Display Register****Figure 104:**  
Capacitive Sensor Display Register

Address 2F <sub>h</sub> : Capacitive Sensor Display Register				Type: R
Bit	Name	Default	Function	Comments
7	cs_cal4		Capacitive Sensor calibration value	Binary weighted, step 0.1 pF, max 3.1 pF
6	cs_cal3			
5	cs_cal2			
4	cs_cal1			
3	cs_cal0			
2	cs_cal_end		<b>1</b> : Calibration ended	
1	cs_cal_err		<b>1</b> : Calibration error	
0				

**Note(s) and/or Footnote(s):**

- At power-up and after [Set Default](#) command, content of this register is set to 0.

**Auxiliary Display Register****Figure 105:**  
Auxiliary Display Register

Address 30 <sub>h</sub> : Auxiliary Display Register				Type: R
Bit	Name	Default	Function	Comments
7	a_cha		<b>0</b> : AM <b>1</b> : PM	Currently selected channel
6	efd_o			External Field Detector output
5	tx_on		<b>1</b> : Transmission is active	
4	osc_ok		<b>1</b> : X-tal oscillation is stable	Indication that x-tal oscillator is active and its output is stable
3	rx_on		<b>1</b> : Receive coder is enabled	
2	rx_act		<b>1</b> : Receive coder is receiving a message	
1	nfc_t		<b>1</b> : External Field Detector is active in peer detection mode	
0	en_ac		<b>1</b> : External Field Detector is active in RF collision avoidance mode	

**Note(s) and/or Footnote(s):**

- At power-up and after [Set Default](#) command, content of this register is set to 0.

**Wake-Up Timer Control Register**

**Figure 106:**  
Wake-Up Timer Control Register

Address 31 <sub>h</sub> : Wake-Up Timer Control Register				Type: RW
Bit	Name	Default	Function	Comments
7	wur	0	<b>0:</b> 100 ms <b>1:</b> 10 ms	Wake-up timer range
6	wut2	0	Refer to <a href="#">Typical Wake-Up Time</a>	Wake-up timer timeout value
5	wut1	0		
4	wut0	0		
3	wto	0	<b>1:</b> IRQ at every timeout	
2	wam	0	<b>1:</b> At timeout perform Amplitude measurement	IRQ if difference larger than $\Delta am$
1	wph	0	<b>1:</b> At timeout perform Phase measurement	IRQ if difference larger than $\Delta pm$
0	wcap	0	<b>1:</b> At timeout perform Capacitance measurement	IRQ if difference larger than $\Delta cm$

**Note(s) and/or Footnote(s):**

1. Default setting is set at power-up and after [Set Default](#) command.

**Figure 107:**  
Typical Wake-Up Time

Typical Wake-Up Time				
wut2	wut1	wut0	100 ms Range (wur=0)	10 ms Range (wur=1)
0	0	0	100 ms	10 ms
0	0	1	200 ms	20 ms
0	1	0	300 ms	30 ms
0	1	1	400 ms	40 ms
1	0	0	500 ms	50 ms
1	0	1	600 ms	60 ms
1	1	0	700 ms	70 ms
1	1	1	800 ms	80 ms



### Amplitude Measurement Configuration Register

**Figure 108:**  
Amplitude Measurement Configuration Register

Address 32 <sub>h</sub> : Amplitude Measurement Configuration Register				Type: RW
Bit	Name	Default	Function	Comments
7	am_d3	0	Definition of $\Delta am$ (difference to reference which triggers interrupt)	
6	am_d2	0		
5	am_d1	0		
4	am_d0	0		
3	am_aam	0	<b>0:</b> Exclude the IRQ measurement <b>1:</b> Include the IRQ measurement	Include/exclude the measurement which causes IRQ (having difference > $\Delta am$ to reference) in auto-averaging
2	am_aew1	0	<b>00:</b> 4 <b>01:</b> 8 <b>10:</b> 16 <b>11:</b> 32	Define weight of last measurement result for auto-averaging
1	am_aew2	0		
0	am_ae	0	<b>1:</b> Use amplitude measurement auto-averaging as reference	

**Note(s) and/or Footnote(s):**

1. Default setting is set at power-up and after [Set Default](#) command.

**Amplitude Measurement Reference Register**

**Figure 109:**  
Amplitude Measurement Reference Register

Address 33 <sub>h</sub> : Amplitude Measurement Reference Register				Type: RW
Bit	Name	Default	Function	Comments
7	am_ref7	0		
6	am_ref6	0		
5	am_ref5	0		
4	am_ref4	0		
3	am_ref3	0		
2	am_ref2	0		
1	am_ref1	0		
0	am_ref0	0		

**Note(s) and/or Footnote(s):**

1. Default setting is set at power-up and after [Set Default](#) command.

**Amplitude Measurement Auto-Averaging Display Register**

**Figure 110:**  
Amplitude Measurement Auto-Averaging Display Register

Address 34 <sub>h</sub> : Amplitude Measurement Auto-Averaging Display Register				Type: R
Bit	Name	Default	Function	Comments
7	am_aad7			
6	am_aad6			
5	am_aad5			
4	am_aad4			
3	am_aad3			
2	am_aad2			
1	am_aad1			
0	am_aad0			

**Note(s) and/or Footnote(s):**

1. At power-up and after [Set Default](#) command, content of this register is set to 0.

### Amplitude Measurement Display Register

**Figure 111:**  
Amplitude Measurement Display Register

Address 35 <sub>n</sub> : Amplitude Measurement Display Register				Type: R
Bit	Name	Default	Function	Comments
7	am_amd7			
6	am_amd6			
5	am_amd5			
4	am_amd4			
3	am_amd3			
2	am_amd2			
1	am_amd1			
0	am_amd0			

**Note(s) and/or Footnote(s):**

1. At power-up and after [Set Default](#) command, content of this register is set to 0.

### Phase Measurement Configuration Register

**Figure 112:**  
Phase Measurement Configuration Register

Address 36 <sub>h</sub> : Phase Measurement Configuration Register				Type: RW
Bit	Name	Default	Function	Comments
7	pm_d3	0	Definition of $\Delta pm$ (difference to reference which triggers interrupt)	
6	pm_d2	0		
5	pm_d1	0		
4	pm_d0	0		
3	pm_aam	0	<b>0:</b> Exclude the IRQ measurement <b>1:</b> Include the IRQ measurement	Include/exclude the measurement which causes IRQ (having difference > $\Delta pm$ to reference) in auto-averaging
2	pm_aew1	0	<b>00:</b> 4 <b>01:</b> 8 <b>10:</b> 16 <b>11:</b> 32	Define weight of last measurement result for auto-averaging
1	pm_aew0	0		
0	pm_ae	0	<b>1:</b> Use phase measurement auto-averaging as reference	

**Note(s) and/or Footnote(s):**

1. Default setting is set at power-up and after [Set Default](#) command.

### Phase Measurement Reference Register

**Figure 113:**  
Phase Measurement Reference Register

Address 37 <sub>n</sub> : Phase Measurement Reference Register				Type: RW
Bit	Name	Default	Function	Comments
7	pm_ref7	0		
6	pm_ref6	0		
5	pm_ref5	0		
4	pm_ref4	0		
3	pm_ref3	0		
2	pm_ref2	0		
1	pm_ref1	0		
0	pm_ref0	0		

**Note(s) and/or Footnote(s):**

1. Default setting is set at power-up and after [Set Default](#) command.

### Phase Measurement Auto-Averaging Display Register

**Figure 114:**  
Phase Measurement Auto-Averaging Display Register

Address 38 <sub>n</sub> : Phase Measurement Auto-Averaging Display Register				Type: R
Bit	Name	Default	Function	Comments
7	pm_aad7			
6	pm_aad6			
5	pm_aad5			
4	pm_aad4			
3	pm_aad3			
2	pm_aad2			
1	pm_aad1			
0	pm_aad0			

**Note(s) and/or Footnote(s):**

1. At power-up and after [Set Default](#) command, content of this register is set to 0.

### Phase Measurement Display Register

**Figure 115:**  
Phase Measurement Display Register

Address 39 <sub>h</sub> : Phase Measurement Display Register				Type: R
Bit	Name	Default	Function	Comments
7	pm_amd7			
6	pm_amd6			
5	pm_amd5			
4	pm_amd4			
3	pm_amd3			
2	pm_amd2			
1	pm_amd1			
0	pm_amd0			

**Note(s) and/or Footnote(s):**

1. At power-up and after [Set Default](#) command, content of this register is set to 0.

### Capacitance Measurement Configuration Register

**Figure 116:**  
Capacitance Measurement Configuration Register

Address 3A <sub>h</sub> : Capacitance Measurement Configuration Register				Type: RW
Bit	Name	Default	Function	Comments
7	cm_d3	0	Definition of $\Delta cm$ (difference to reference which triggers interrupt)	
6	cm_d2	0		
5	cm_d1	0		
4	cm_d0	0		
3	cm_aam	0	<b>0:</b> Exclude the IRQ measurement <b>1:</b> Include the IRQ measurement	Include/exclude the measurement which causes IRQ (having difference > $\Delta cm$ to reference) in auto-averaging
2	cm_aew1	0	<b>00:</b> 4 <b>01:</b> 8 <b>10:</b> 16 <b>11:</b> 32	Define weight of last measurement result for auto-averaging
1	cm_aew0	0		
0	cm_ae	0	<b>1:</b> Use capacitance measurement auto-averaging as reference	

**Note(s) and/or Footnote(s):**

1. Default setting is set at power-up and after [Set Default](#) command.

**Capacitance Measurement Reference Register**

**Figure 117:**  
Capacitance Measurement Reference Register

Address 3B <sub>n</sub> : Capacitance Measurement Reference Register				Type: RW
Bit	Name	Default	Function	Comments
7	cm_ref7	0		
6	cm_ref6	0		
5	cm_ref5	0		
4	cm_ref4	0		
3	cm_ref3	0		
2	cm_ref2	0		
1	cm_ref1	0		
0	cm_ref0	0		

**Note(s) and/or Footnote(s):**

1. Default setting is set at power-up and after [Set Default](#) command.

**Capacitance Measurement Auto-Averaging Display Register**

**Figure 118:**  
Capacitance Measurement Auto-Averaging Display Register

Address 3C <sub>n</sub> : Capacitance Measurement Auto-Averaging Display Register				Type: R
Bit	Name	Default	Function	Comments
7	cm_aad7			
6	cm_aad6			
5	cm_aad5			
4	cm_aad4			
3	cm_aad3			
2	cm_aad2			
1	cm_aad1			
0	cm_aad0			

**Note(s) and/or Footnote(s):**

1. At power-up and after [Set Default](#) command, content of this register is set to 0.



### Capacitance Measurement Display Register

**Figure 119:**  
Capacitance Measurement Display Register

Address 3D <sub>h</sub> : Capacitance Measurement Display Register				Type: R
Bit	Name	Default	Function	Comments
7	cm_amd7			
6	cm_amd6			
5	cm_amd5			
4	cm_amd4			
3	cm_amd3			
2	cm_amd2			
1	cm_amd1			
0	cm_amd0			

**Note(s) and/or Footnote(s):**

1. At power-up and after [Set Default](#) command, content of this register is set to 0.

### IC Identity Register

**Figure 120:**  
IC Identity Register

Address 3F <sub>h</sub> : IC Identity Register				Type: R
Bit	Name	Default	Function	Comments
7	ic_type4		Code for AS3911B: 00001	5 bit IC type code
6	ic_type3			
5	ic_type2			
4	ic_type1			
3	ic_type0			
2	ic_rev2		010: silicon r3.1 011: silicon r3.3 100: silicon r4.0	3 bit IC revision code
1	ic_rev1			
0	ic_rev0			

## Power-Up Sequence

At power-up, the AS3911B enters the Power-down mode. The content of all registers is set to the default state.

1. Firstly, the microcontroller after a power-up must correctly configure the two IO configuration registers. The content of these two registers defines operation options related to hardware (power supply mode, Xtal type, use of MCU\_CLK clock, antenna operation mode).
2. Configure the regulators. It is recommended to use direct command [Adjust Regulators](#) to improve the system PSRR.
3. If implementing the LC tank tuning, then send the direct command [Calibrate Antenna](#).
4. If using the AM modulation (ISO14443B for example), then set the modulation depth in the [AM Modulation Depth Control Register](#) and send the command [Calibrate Modulation Depth](#).
5. The AS3911B is now ready to operate.

## Reader Operation

To begin with, the operation mode and data rate have to be configured by writing the [Mode Definition Register](#) and [Bit Rate Definition Register](#). Additionally, the receiver and transmitter operation options related to operation mode have to be defined. This is done automatically by sending the direct command [Analog Preset](#). If more options are required apart from those defined by [Analog Preset](#), then such options must be additionally set by writing the appropriate registers.

Next, the Ready mode has to be entered by setting the bit *en* of the [Operation Control Register](#). In this mode the oscillator is started and the regulators are enabled. When the oscillator operation is stable, an interrupt is sent.

Before sending any command to a transponder, the transmitter and receiver have to be enabled by setting the bits *rx\_en* and *tx\_en*. RFID protocols usually require that the reader field is turned on for a while before sending the first command (5 ms for ISO14443). General purpose timer can be used to count this time.

In case REQA or WUPA has to be sent this is simply done by sending appropriate direct command otherwise the following sequence has to be followed:

1. Send the direct command [Clear](#)
2. Define the number of transmitted bytes in the [Number of Transmitted Bytes Register 1](#) and [Number of Transmitted Bytes Register 2](#)
3. Write the bytes to be transmitted in the FIFO
4. Send the direct command [Transmit With CRC](#) or [Transmit Without CRC](#) (whichever is appropriate)
5. When all the data is transmitted an interrupt is sent to inform the microcontroller that the transmission is finished (IRQ due to end of transmission)

After the transmission is executed, the AS3911B receiver automatically starts to observe the RFI inputs to detect a transponder response. The RSSI and AGC (in case it is enabled) are started. The framing block processes the sub-carrier signal from receiver and fills the FIFO with data. When the reception is finished and all the data is in the FIFO an interrupt is sent to the microcontroller (IRQ due to end of receive), additionally the [FIFO Status Register 1](#) and [FIFO Status Register 2](#) display the number of bytes in the FIFO so the microcontroller can proceed with downloading the data.

In case there was an error or bit collision detected during reception, an interrupt with appropriate flag is sent. Microcontroller has to take appropriate action.

***Transmit and Receive in Case Data Packet is Longer than FIFO:***

In case a data packet is longer than FIFO the sequence explained above is modified.

Before transmit the FIFO is filled. During transmit an interrupt is sent when remaining number of bytes is lower than the water level (IRQ due to FIFO water level). The microcontroller in turn adds more data in the FIFO. When all the data is transmitted an interrupt is sent to inform the microcontroller that transmission is finished.

During reception situation is similar. In case the FIFO is loaded with more data than the receive water level, an interrupt is sent and the microcontroller in turn reads the data from the FIFO. When reception is finished an interrupt is sent to the microcontroller (IRQ due to end of receive), additionally the [FIFO Status Register 1](#) and [FIFO Status Register 2](#) display the number of bytes in the FIFO which are still to be read out.

***Anticollision – ISO 14443A***

**Note(s):** For this section, it is assumed that there are more than one ISO/IEC 14443A PICC in the reader's RF field and all are compatible to ISO/IEC 14443 up to level 4.

This section highlights on a procedure of performing anticollision with AS3911B for ISO14443A tags. After an ISO14443 type A tag enters in the reader field, the reader has

to perform a selection process which brings it into the PROTOCOL state in which the actual application implemented in the tag can be executed. This selection process is described in the ISO/IEC 14443-3. The Figure 121 depicts the states which a tag and a reader have to pass through to enter the protocol state.

**Figure 121:**  
ISO14443A States for PCD and PICC

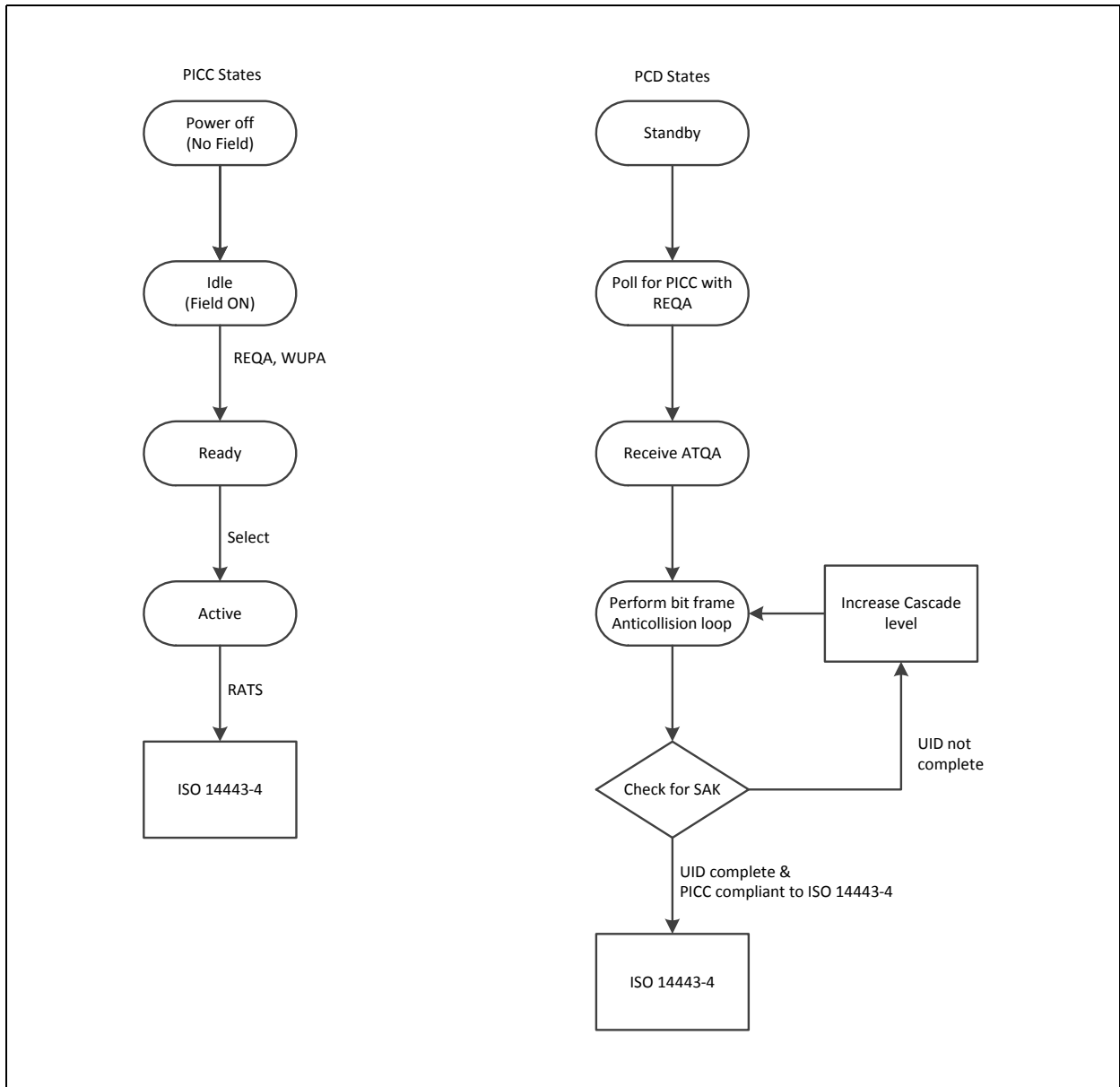

The selection procedure starts when a PICC enters the reader field and the PCD sends a REQA (or WUPA) command followed by an Anticollision procedure (incl. SELECT, RATS and PPS).

### Setting up AS3911B for ISO 14443A Anticollision

To setup the AS3911B for the ISO14443A anticollision following steps are to be followed:

1. The Initiator operation mode of AS3911B must be setup for ISO 14443A in the [Mode Definition Register](#) (default is already for ISO14443A).
2. The Tx and Rx bit rates must be set up to default 106kbps in the [Bit Rate Definition Register](#).
3. Set the *antcl* bit in the [ISO14443A and NFC 106kb/s Settings Register](#). This needs to be set before sending the REQA (or WUPA). As a result of setting this bit, the AS3911B will not trigger a framing error if in case the collision occurs in the ATQA or during anticollision procedure.

**Note(s):** This bit must be set to one for REQA, WUPA and ANTOCOLLISION commands, for other commands it has to be zero.

4. Review and set the value for [Mask Receive Timer Register](#) less than the Frame delay time as required by the ISO14443A. And set the [No-Response Timer Register 1&No-Response Timer Register 2](#) according to the requirements. This is typically larger than the FDT.

**Note(s):** AS3911B offers the resolution of  $n/2$  ( $64/fc$  - half steps) compared to  $n$  ( $128/fc$ ) as mentioned in 14443A so that the receiver can be unmasked  $n/2$  step before the actual transmission from the PIC.

5. According to ISO 14443A the FDT must be  $1236/fc$  if last transmitter bit is 1 or  $1172/fc$  if last transmitter bit is 0. As a simple rule one can follow the following.

**Figure 122:**  
Selection of MRT & NRT for a Given FDT

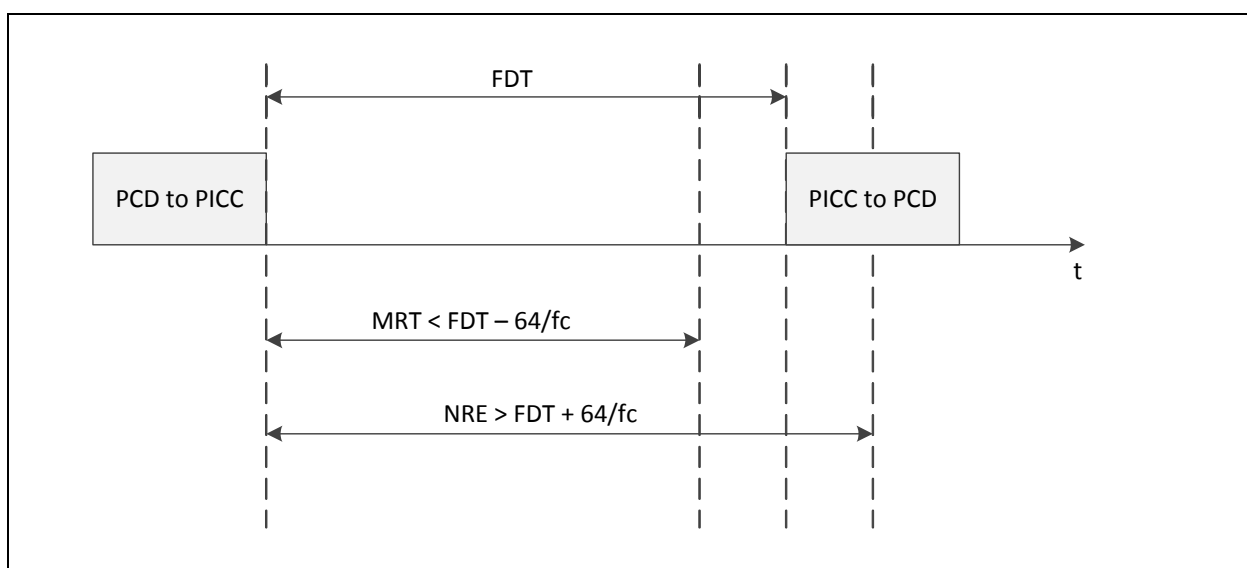

6. The receiver and transmitter operation options related to operation mode have to be defined. This is done automatically by sending the direct command [Analog Preset](#). If different options are required apart from those defined by [Analog Preset](#), then such options must be additionally set by writing the appropriate registers.
7. Set *rx\_en* and *tx\_en* in the [Operation Control Register](#). RFID protocols usually require that the reader field is turned on for a while before sending the first command (5 ms for ISO14443). General purpose timer can be used to count this time.
8. The reply form PICC for the REQA, WUPA and replies within ANTICOLLISION sequence before till before SAK do not contain CRC. In this case the *no\_CRC\_rx* bit in the [Auxiliary Definition Register](#) must be set to 1 (receive without CRC) before sending these commands.

### **REQA and WUPA**

Sending of these two commands is simple since they are implemented as the AS3911B direct commands (Transmit REQA and Transmit WUPA). The end of transmission of these commands is signaled to microcontroller by an interrupt - IRQ (due to end of transmission). After the transmission is executed, the AS3911B receiver automatically starts to observe the RFI inputs to detect a transponder after the expiration of the Mask Receive Timer.

As a response to REQA (or WUPA) all the PICC in the field respond simultaneously with an ATQA. A collision can occur in this state if there are PICC with different UID size or has the Bit frame anticollision bits set differently. Hence it is important to set the *antcl* bit to 1. If there is any IRQ (except *l\_nre*) that AS3911B signals, the microcontroller must consider as a valid presence of tag and must proceed with the ANTICOLLISION procedure.

If more than one PICC are expected in the field, following algorithm must be used to select multiple tags:

1. Send REQA, if there was any answer continue
2. Perform anticollision, and singulate one PICC
3. Select the found Tag and send HLTA to move it to HALT state
4. Go to 1 and repeat this procedure till all the PICC are in HALT state and all the UIDs have been extracted.

### **ANTICOLLISION Procedure**

After receiving the ATQA from the tags in the field, the next step is to execute the anticollision procedure to singulate the tags. the procedure mainly uses the ANTICOLLISION and SELECT commands which consist of:

- Select code SEL (1byte)
- Number of valid bits NVB (1 byte)
- 0 to 40 data bits of UID CLn according to the value of NVB

The anticollision command uses standard frame which do not use CRC. In this case the transmit needs to be done with direct command [Transmit Without CRC](#) and for the receive, the *no\_CRC\_rx* bit in the [Auxiliary Definition Register](#) must be set to 1. The final SELECT command and its response SAK contains a CRC, so the transmit needs to be done with command [Transmit With CRC](#) and before sending this command the configuration bit *no\_CRC\_rx* bit in the [Auxiliary Definition Register](#) must be set back to 0.

If there are more than one PICC in the field, the collision will occur when the tags reply to the SEL command during anticollision when the PICC reply back with their UID. This collision can occur after a complete byte (called as FULL BYTE scenario) or it can occur within a byte (called as SPLIT BYTE scenario). The *antcl* bit in [ISO14443A and NFC 106kb/s Settings Register](#) must be set during this procedure too. As a result, AS3911B will not trigger a Framing Error. This bit is also responsible for correct timing of anticollision and correct parity extraction.

**Note(s):** It must only be set before sending an anticollision frame, REQA or WUPA. This bit must not be used in any other commands.

The [Figure 123](#) depicts the flowchart on how to implement the anticollision with AS3911B.

**Figure 123:**  
**Flowchart for ISO14443A Anticollision with AS3911B**

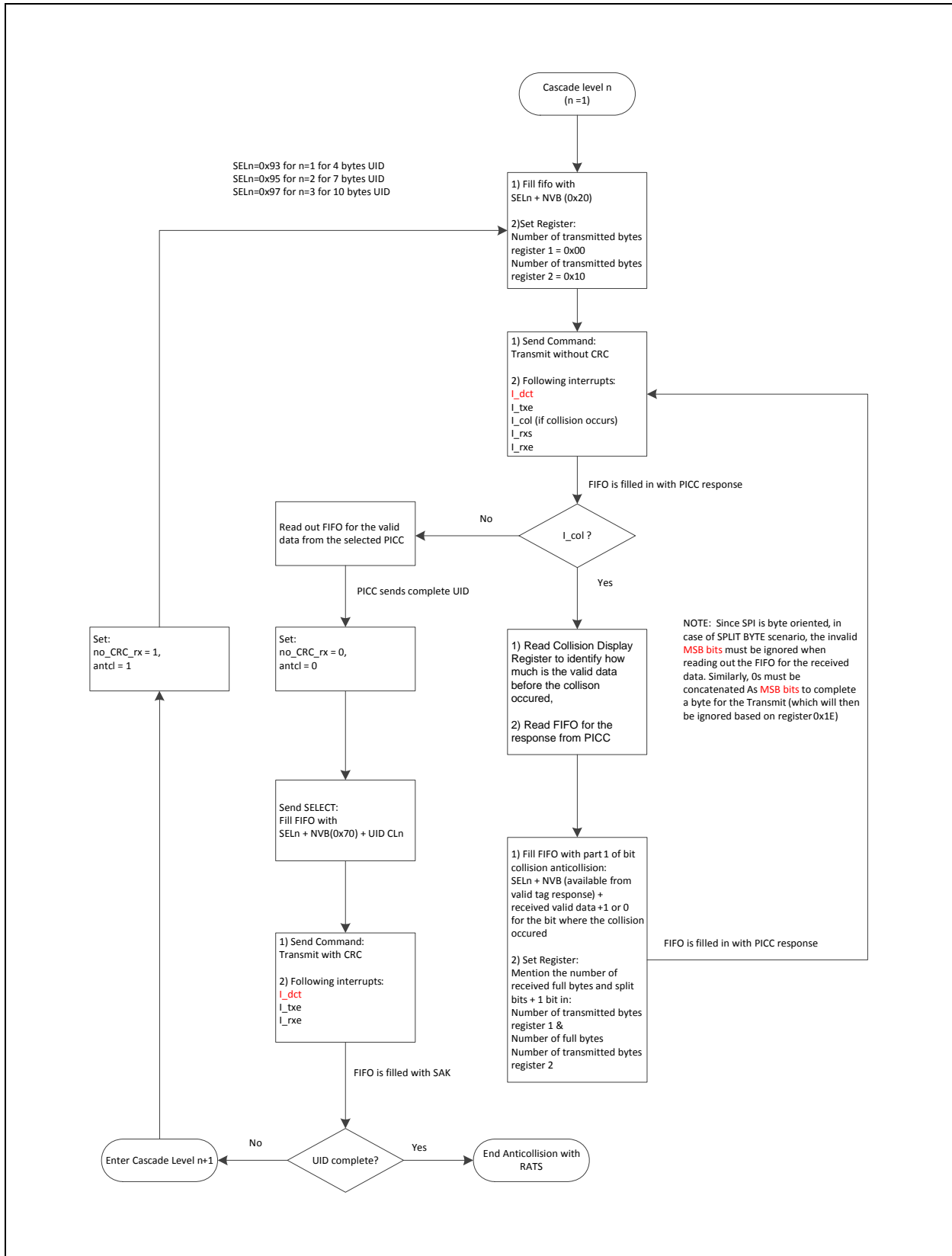



## FeliCa Reader Mode

The general recommendation from previous chapter is valid also for FeliCa reader mode. Bit rates 212 and 424 kb/s are supported. Bit rates are the same in both (reader to tag and tag to reader) directions. Modulation reader to tag is AM.

In FeliCa mode the FeliCa frame format is supported.

**Figure 124:**  
**FeliCa Frame Format**

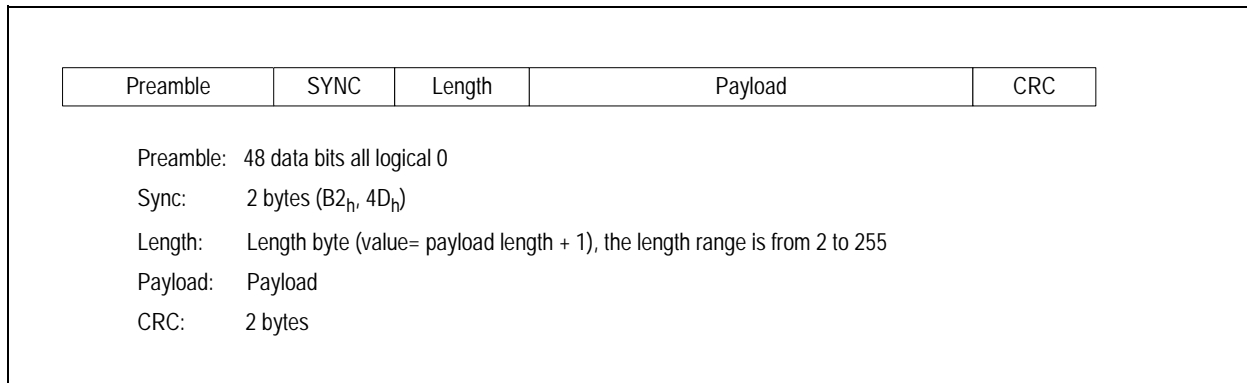

### FeliCa Transmission

In order to transmit FeliCa frame only the Payload data is put in the FIFO. The number of Payload bytes is defined in the [Number of Transmitted Bytes Register 1](#) and [Number of Transmitted Bytes Register 2](#). Preamble length is defined by bits  $f\_p1$  and  $f\_p0$  in the [ISO14443B](#) and [FeliCa Settings Register](#), default value is 48 bits, but also other options are possible.

Transmission is triggered by sending direct command [Transmit With CRC](#). First preamble is sent, followed by SYNC and Length bytes. Then Payload stored in FIFO is sent, transmission is terminated by two CRC bytes which are calculated by the AS3911B. Length byte is calculated from 'number of transmitted bytes'. The following equation is used:

$$\text{length} = \text{payload length} + 1 = \text{number of transmitted bytes} + 1$$

### FeliCa Reception

After transmission is done the AS3911B logic starts to parse the receiver output to detect the Preamble of FeliCa tag reply.

Once the Preamble followed by the two SYNC bytes is detected the Length byte and Payload data are put in the FIFO. CRC bytes are internally checked.

### NFCIP-1 Operation

The AS3911B supports all NFCIP-1 initiator modes and active communication target modes. All NFCIP-1 bit rates (106, 212 and 424 kbit/s) are supported.

**NFCIP-1 Passive Communication Initiator**

NFCIP-1 passive communication is equivalent to reader (PCD) to tag (PICC) communication where initiator acts as a reader and target acts as tag. The only difference is that in case of the NFCIP-1 passive communication the initiator performs Initial RF Collision Avoidance procedure at the beginning of communication.

In order to act as NFCIP-1 passive communication initiator the AS3911B has to be configured according to table below:

**Figure 125:**  
**Operation Mode and Bit Rate Setting for NFCIP-1 Passive Communication**

NFCIP-1 Bit Rate [kb/s]	Operation Mode Setting	Bit Rate for Tx [kb/s]	Bit Rate for Rx [kb/s]	Comment
106	ISO14443A	fc/128 (~106)	fc/128 (~106)	
212	FeliCa	fc/64 (~212)	x	In FeliCa mode data rate is the same in both directions
424	FeliCa	fc/32 (~424)	x	

Initial set-up of the [Operation Control Register](#) before the start of communication is the same as in case of reader to tag communication, with the exception that the transmitter is not enabled by setting the *tx\_en* bit. The direct command [NFC Initial Field ON](#) is sent instead.

This command first performs the Initial RF Collision avoidance with Collision Avoidance Threshold defined in the [External Field Detector Threshold Register](#). The timing of collision avoidance is according to NFCIP-1 standard (for timing details see [Figure 41](#)). In case collision is not detected the *tx\_en* bit is automatically set to switch the transmitter on. After minimum guard time  $T_{IRFG}$  the *I\_cat* IRQ is sent to inform controller that the first initiator command can be send.

From this point on communication is the same as in case of ISO14443A (for 106 kb/s) or FeliCa (for 242 and 424 kb/s) reader communication.

In case a presence of external field is detected an *I\_cac* IRQ is sent. In such case a transmission should not be performed, command [NFC Initial Field ON](#) has to be repeated as long as collision is not detected any more.

Initial collision avoidance is not limited to modes supported by NFCIP-1. The initial collision avoidance according to procedure described above can be performed before any reader mode is started to avoid collision with an HF reader or an NFC device operating in proximity.

**Support of NFCIP-1 Transport Frame Format**

[Figure 126](#) depicts the Transport Frame according to NFCIP-1 standard.

**Figure 126:**  
**Transport Frame Format According to NFCIP-1**

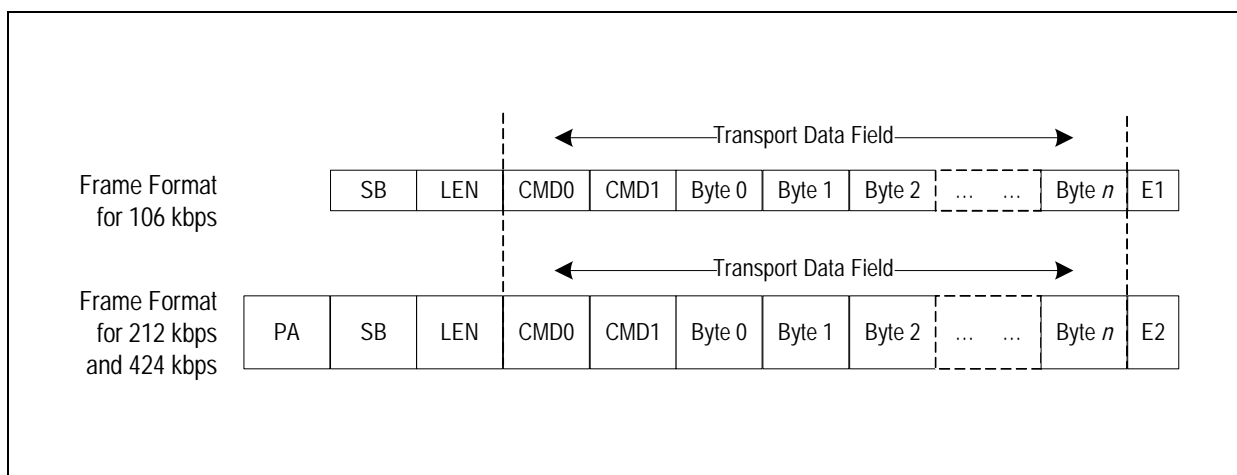

Transport Frame for bit rate 212 and 424 kb/s has the same format as communication frame used during Initialization and SDD. This format is also used in FeliCa protocol (see also [FeliCa Reader Mode](#)). In case of 106 kb/s the SB (Start byte at F0<sub>h</sub>) and LEN (length byte) are only used in Transport Frame.

Support of Transport Frame for 106 kb/s NFCIP-1 communication is enabled by setting bit nfc\_f0 in the [ISO14443A and NFC 106kb/s Settings Register](#).

Once this bit is set and ISO 14443A mode with bit rate 106 kb/s is configured, the behavior of the AS3911B framing is as follows:

#### **Transmission**

In order to transmit a Transport Frame only the Transport Data has to be put in FIFO. The number of Transport Data bytes is defined in the [Number of Transmitted Bytes Register 1](#) and [Number of Transmitted Bytes Register 2](#). Transmission is triggered by sending direct command [Transmit With CRC](#). First Start byte with value F0<sub>h</sub> followed by Length byte are sent. Then Transport Data stored in FIFO is sent, transmission is terminated by two CRC bytes (E1 in [Figure 126](#)) which are calculated by the AS3911B. Length byte is calculated from 'number of transmitted bytes'. The following equation is used:

$$\text{length} = \text{Transport Data length} + 1 = \text{number of transmitted bytes} + 1$$

#### **Reception**

After transmission is done the AS3911B logic starts to parse the receiver output to detect the start of tag reply.

Once the start of communication sequence is detected the first byte (Start Byte with value F0<sub>h</sub>) is checked the Length byte and Transport Data bytes are put in the FIFO. CRC bytes are internally checked. In case the Start byte is not equal to F0<sub>h</sub> the following data bytes are still put in FIFO, additionally a soft framing error IRQ is set to indicate the Start Byte error.

**NFCIP-1 Active Communication Initiator**

During NFCIP-1 active communication both, initiator and target switch on its field when transmitting and switch off its field when receiving. In order to operate as NFCIP-1 active communication initiator the AS3911B has to be configured according to table below (bit *targ* in the [Mode Definition Register](#) has to be 0):

**Figure 127:**  
**Operation Mode and Bit Rate Setting for NFCIP-1 Active Communication Initiator**

NFCIP-1 Bit Rate [kb/s]	Initiator Operation Mode Setting	Bit Rate for Tx [kb/s]	Bit Rate for Rx [kb/s]	Comment
106	NFCIP-1 active communication	fc/128 (~106)	x	For all NFCIP-1 communication, data rate is the same in both directions.
212	NFCIP-1 active communication	fc/64 (~212)	x	
424	NFCIP-1 active communication	fc/32 (~424)	x	

After selecting the NFCIP-1 active communication mode the Receiver and Transmitter have to be configured properly. This configuration can be done automatically by sending direct command [Analog Preset](#) (see [Analog Preset](#)).

During NFCIP-1 active communication the RF Collision avoidance and switching on the field is performed using ‘NFC Field ON’ commands (see [NFC Field ON Commands](#)), while the sending of message is performed using Transmit commands as in the case of reader communication. Alternatively the Response RF Collision Avoidance sequence is started automatically when the switching off of target field is detected in case the bit *nfc\_ar* in the [Mode Definition Register](#) is set.

When NFCIP-1 mode is activated the External Field Detector is automatically enabled by setting bit *en\_fd* in the [Auxiliary Display Register](#). The Peer Detection Threshold is used to detect target field. During execution of ‘NFC Field ON’ commands, the Collision Avoidance Threshold is used.

Initial set-up of the [Operation Control Register](#) before the start of communication is the same as in case of reader to tag communication with the exception that the transmitter is not enabled by setting the *tx\_en* bit. The *tx\_en* bit and therefore switching on of the transmitter is controlled by NFC Field ON commands. Switching off the field is performed automatically after a message has been sent. The [General Purpose and No-Response Timer Control Register](#) is used to define the time during which the field stays switched on after a message has been transmitted.

In order to receive the NFCIP-1 active reply only the AM demodulation channel is used. Due to this the Receiver AM channel has to be enabled. The preset done by [Analog Preset](#) command enables only the AM demodulation channel, while PM channel is disabled to save current.

In NFCIP-1 active communication the NFCIP-1Transport Frame format (see [Figure 126](#)) is always used. Due to this the [ISO14443A and NFC 106kb/s Settings Register](#) bit *nfc\_f0* is set by Analog Preset command (see [Support of NFCIP-1Transport Frame Format](#)).

NFCIP-1 active communication sequence when bit *nfc\_ar* in the [Mode Definition Register](#) is set (automatic Response RF Collision Avoidance sequence). During this sequence bits *nfc\_n1* and *nfc\_n0* of the [Auxiliary Definition Register](#) have to be 0 to produce Response Collision Avoidance sequence with  $n=0$ :

1. First the direct command [NFC Initial Field ON](#) is sent. In case no collision was detected during RF collision avoidance the field is switched on and an IRQ with *l\_cat* flag set is sent to controller after  $T_{IRFG}$ .
2. The message, which was prepared as in case of reader to tag communication, is transmitted using Transmit command.
3. After the message is sent the field is switched off. The time between the end of the message and switching off the field is defined by the General Purpose Timer. (The General Purpose Timer IRQ may be masked since controller does not need this information).
4. After switching off its field the AS3911B starts the No-Response Timer and observes the External Field Detector output to detect the switching on of the target field. In case the target field is not detected before No-Response Timer timeout, an IRQ due No-Response Timer expire is sent.
5. When Target field is detected an IRQ with *l\_eon* flag set is sent to controller and Mask-receive Timer is started. After the Mask Receive Timer expires the receiver output starts to be observed to detect start of the target response. The reception process goes on as in case of reader to tag communication.
6. When the External Field Detector detects that the target has switched off its field, it sends an IRQ with *l\_eof* flag set to the controller, and in case bit *nfc\_ar* is set automatically activates the sequence of direct command [NFC Response Field ON](#). In case no collision is detected during RF collision avoidance the field is switched on and an IRQ with *l\_cat* flag set is sent to controller after  $T_{ARFG}$ .

7. Sequence loops through point 2. In case the last initiator command is sent in next sequence (DLS\_REQ in case of NFCIP-1 protocol) the bit *nfc\_ar* in the [Mode Definition Register](#) has to be put to 0 to avoid switching on the initiator field after the target has switched of its field.

### **NFCIP-1 Active Communication Target**

The AS3911B target mode is activated by setting bit *targ* in the [Mode Definition Register](#) to 1. When target mode is activated the External Field Detector is automatically enabled by setting bit *en\_fd* in the [Auxiliary Definition Register](#).

When bit *targ* is set and all bits of the [Operation Control Register](#) are set to 0, the AS3911B is in low power Initial NFC Target Mode. In this mode the External Field Detector with Peer Detection Threshold is enabled.

There are two different NFC target modes implemented (defined by mode bits of the [Mode Definition Register](#)): the bit rate detection mode and normal mode. In the bit rate detection mode the framing logic performs automatic detection of the initiator data rate and writes it in the [NFCIP Bit Rate Detection Display Register](#). In the normal mode it is supposed that the data rate defined in the [Bit Rate Definition Register](#) is used.

After selecting the NFCIP-1 active target mode the Receiver and Transmitter have to be configured properly. Configuration is the same as in case of NFCIP-1 active initiator mode. This configuration can be done automatically by sending direct command [Analog Preset](#) (see [Analog Preset](#)).

NFCIP-1 active communication sequence when bit *nfc\_ar* in the [Mode Definition Register](#) is set (automatic Response RF Collision Avoidance sequence). During this sequence bits *nfc\_n1* and *nfc\_n0* of the [Auxiliary Definition Register](#) have to be 0 to produce Response Collision Avoidance with  $n=0$ .

The following sequence assumes that the AS3911B is in the low power Initial NFC Target Mode with the bit rate detection mode selected. Bit *nfc\_ar* in the [Mode Definition Register](#) is set (automatic Response RF Collision Avoidance sequence). When the initiator field is detected the following sequence is executed:

1. An IRQ with *I\_eon* flag set is sent to the controller.
2. The controller turns on the oscillator, regulator and receiver. Mask-receive Timer is started by sending direct command [Start Mask-Receive Timer](#). After the Mask Receive Timer expires the receiver output starts to be observed to detect start of the initiator message.
3. Once the start of initiator message is detected, an IRQ due to start of receive is sent, the framing logic switches on a module which automatically recognizes the bit rate of signal sent by the initiator. Once the bit rate is recognized an IRQ with *I\_nfct* flag set is sent and the bit rate is automatically loaded in the [NFCIP Bit Rate Detection Display Register](#). Detection of bit rate is also a condition that automatic Response RF Collision

Avoidance sequence is enabled). The received message is decoded and put into the FIFO, IRQ is sent as after any received message.

4. The controller sends direct command [Go to Normal NFC Mode](#), to copy the content of the [NFCIP Bit Rate Detection Display Register](#) to the Bit Rate Definition Register and to change the NFCIP-1 target mode to normal (the command Go To Normal Mode and reading of received data can be chained). Since the Tx modulation type depends on bit rate, the Tx modulation type also has to be correctly set at this point.
5. When the External Field Detector detects that the target has switched off its field, it sends an IRQ with *l\_eof* flag set to the controller, and in case bit *nfc\_ar* is set automatically activates the sequence of direct command [NFC Response Field ON](#). Bits *nfc\_n1* and *nfc\_n0* of the [Auxiliary Definition Register](#) are used to define number n of Response RF Collision Avoidance sequence. In case no collision is detected during RF collision avoidance the field is switched on and an IRQ with *l\_cat* flag set is sent to controller after  $T_{ARFG}$ .
6. The reply, which was prepared as in case of reader to tag communication is transmitted using Transmit command.
7. After the message is sent the field is switched off. The time between the end of the message and switching off the field is defined in the General Purpose Timer. (The General Purpose Timer IRQ may be masked since controller does not need this information).

From this point on the communication with initiator loops through the following sequence (during this sequence bits *nfc\_n1* and *nfc\_n0* of the [Auxiliary Definition Register](#) have to be 0 to produce Response RF Collision Avoidance with n=0):

1. After switching off its field the AS3911B starts the No-Response Timer and observes the External Field Detector output to detect the switching on of the initiator field. In case the initiator field is not detected before No-Response Timer timeout, an IRQ due No-Response Timer expire is sent.
2. When initiator field is detected an IRQ with *l\_eon* flag set is sent to controller and Mask-Receive Timer is started. After the Mask Receive Timer expires the receiver output starts to be observed to detect start of the initiator response. The reception process goes on as in case of reader to tag communication.
3. When the External Field Detector detects that the target has switched off its field, it sends an IRQ with *l\_eof* flag set to the controller, and in case bit *nfc\_ar* is set automatically activates the sequence of direct command [NFC Response Field ON](#). In case no collision is detected during RF collision avoidance the field is switched on and an IRQ with *l\_cat* flag set is sent to controller after  $T_{ARFG}$ .

4. The reply which was prepared as in case of reader to tag communication is transmitted using Transmit command
5. After the message is sent the field is switched off. The time between the end of the message and switching off the field is defined in General Purpose Timer. In case a new command from initiator is expected the General Purpose Timer IRQ may be masked since controller does not need this information.
6. In case a new command from Initiator is expected the sequence loops through point 1. In case the target reply was the last in a sequence (DLS\_RES in case of NFCIP-1 protocol) a new command from initiator is not expected. At the moment the field is switched off, a General Purpose Timer IRQ is received and the AS3911B is put back in the low power NFC Target Mode by deactivating the [Operation Control Register](#). NFC mode is changed back to rate detection mode by writing the [Mode Definition Register](#).

### AM Modulation Depth: Definition and Calibration

The AS3911B Transmitter supports OOK and AM modulation. The choice between OOK and AM modulation is done by writing [Auxiliary Definition Register](#) bit *tr\_am*. AM modulation is preset by direct command [Analog Preset](#) in case the following protocols are configured:

- ISO14443B
- FeliCa
- NFCIP-1 212 and 424 kb/s

The AM modulation depth can be automatically adjusted by setting the [AM Modulation Depth Control Register](#) and sending the direct command [Calibrate Modulation Depth](#). There is also an alternative possibility where the command [Calibrate Modulation Depth](#) is not used and the modulated level is defined by writing the Antenna driver [RFO AM Modulated Level Definition Register](#).



### **AM Modulation Depth Definition Using the 'Calibrate Modulation Depth' Direct Command**

Before sending the direct command [Calibrate Modulation Depth](#) the [AM Modulation Depth Control Register](#) has to be configured in the following way:

- The bit 7 (*am\_s*) has to be set to 0 to choose definition by the command [Calibrate Modulation Depth](#)
- Bits 6 to 1 (*mod5* to *mod0*) define target AM modulation depth

#### **Definition of Modulation Depth Using Bits *mod5* to *mod0*:**

The RFID standard documents usually define the AM modulation level in form of the modulation index. The modulation index is defined by formula  $(a-b)/(a+b)$  where *a* is amplitude of the non-modulated carrier and *b* is the amplitude of the modulated carrier.

The modulation index specification is different for different standards. The ISO14443B modulation index is typically 10% with allowed range from 8% to 14%, range from 10 to 30% is defined in the ISO15693 and 8% to 30% in the FeliCa™ and NFCIP-1 212 kb/s and 424 kb/s.

The bits *mod5* to *mod0* are used to calculate the amplitude of the modulated level. The non-modulated level which was before measured by the A/D converter and stored in an 8 bit register is divided by a binary number in range from 1 to 1.98. The bits *mod5* to *mod0* define binary decimals of this number.

#### **Example:**

In case of the modulation index 10% the modulated level amplitude is 1.2222 times lower than the non-modulated level. 1.2222 converted to binary and truncated to 6 decimals is 1.001110. So in order to define the modulation index 10% the bits *mod5* to *mod0* have to be set to 001110.

The table below depicts setting of the mod bits for some often used modulation indexes.

**Figure 128:**  
**Setting of the mod Bits for Some Often Used Modulation Indexes**

Modulation Index [%]	a/b [dec]	a/b [bin]	mod5.....mod0
8	1.1739	1.001011	001011
10	1.2222	1.001110	001110
14	1.3256	1.010100	010100
20	1.5000	1.100000	100000
30	1.8571	1.110111	110111
33	1.9843	1.111111	111111

**Execution of Direct Command 'Calibrate Modulation Depth':**

The modulation level is adjusted by increasing the RFO1 and RFO2 driver output resistance. The RFO drivers are composed of 8 binary weighted segments. Usually all these segments are turned on to define the normal, non-modulated level, there is also a possibility to increase the output resistance of the non-modulated state by writing the [RFO Normal Level Definition Register](#).

Before sending the direct command [Calibrate Modulation Depth](#) the oscillator and regulators have to be turned on. When the direct command [Calibrate Modulation Depth](#) is sent the following procedure is executed:

- The Transmitter is turned on, non-modulated level is established.
- The amplitude of the non-modulated carrier level established on the inputs RF11 and RF12 is measured by the A/D converter and stored in the [A/D Converter Output Register](#).
- Based on the measurement of the non-modulated level and the target modulated level defined by the bits mod5 to mod0 the target modulated level is calculated.
- The output driver control is taken over by the *Calibrate Register*. Content of the *Calibrate Register* is modified using successive approximation algorithm as long as long as the measured level is equal or as close as possible to target modulated level calculated in previous step.
- Final state of the *Calibrate Register* is copied in the [AM Modulation Depth Display Register](#). Content of this register is used to define the AM modulated level.

**Note(s):** After this calibration procedure is finished, the content of the [RFO Normal Level Definition Register](#) should not be changed. Modification of this register content will change the non-modulated amplitude and therefore the ratio between the modulated and non-modulated level will be changed. Please also note that in case the calibration of antenna resonant frequency in used, command [Calibrate Antenna](#) has to be run before AM modulation depth adjustment.

**AM Modulation Depth Definition using the 'RFO AM Modulated Level Definition' Register**

When the bit 7 (*am\_s*) of the [AM Modulation Depth Control Register](#) is set to 1 the AM modulated level is controlled by writing the [RFO AM Modulated Level Definition Register](#). In case setting of the modulated level is already known it is not necessary to run the calibration procedure, the modulated level can simply be defined by writing this register.

It is also possible to implement calibration procedure in external controller using the [RFO Normal Level Definition Register](#) and the direct command [Measure Amplitude](#). This procedure has to be used in case the target modulation depth is deeper than 33%.

The procedure is the following:

- Write the non-modulated level in the [RFO Normal Level Definition Register](#) (usually it is all 0 to have the lower possible output resistance).
- Switch on the transmitter.
- Send the direct command [Measure Amplitude](#). Read result from the [A/D Converter Output Register](#).
- Calculate the target modulated level from the target modulation index and result of the previous point.
- In the following iterations content of the [RFO Normal Level Definition Register](#) is modified, the command [Measure Amplitude](#) executed and result compared to the target modulated level as long as the result is not equal or as close as possible to the target modulated level.
- At the end the content of the [RFO Normal Level Definition Register](#) which results in the target modulated level is written in the [RFO AM Modulated Level Definition Register](#) while the [RFO Normal Level Definition Register](#) is restored with the non-modulated definition value.

## Antenna Tuning

The AS3911B comprises the building blocks which make possible checking and adjustment of the antenna LC tank resonance frequency. The AS3911B Phase and Amplitude Detector block is used for resonance frequency checking and adjustment.

In order to implement the antenna LC tank calibration tuning capacitors have to be connected between the two coil terminals to the pins TRIM1\_3 to TRIM1\_0 and TRIM2\_3 to TRIM2\_0. In case single driver is used only the pins TRIM1\_3 to TRIM1\_0 are used, pins TRIM2\_3 to TRIM2\_0 are left open. [Figure 129](#) depicts connection of the trim capacitors for both, single and differential driving for the simple case where the antenna LC tank is directly connected to RFO pins.

The TRIM pins contain the HVNMOS switching transistors to  $V_{SS}$ . The on resistance of TRIM1\_0 and TRIM2\_0 switch transistors, which are meant to be connected to LSB tuning capacitor is  $50\ \Omega$  typ. at  $3\ V_{VSP\_D}$ , the on resistance of other pins is binary weighted (the on resistance of TRIM1\_3 and TRIM2\_3 is  $6.25\ \Omega$  typ.) The breakdown voltage of the HVNMOS switch transistors is 25V, which limits the maximum peak to peak voltage on LC tank in case tuning is used.

During tuning procedure the resonance frequency is adjusted by connecting some of the tuning capacitors to  $V_{SS}$  and leaving others floating. The Switches of the same binary weight are driven from the same source and are both on or off (the switches TRIM1\_2 and TRIM2\_2 are for example both either on or off).

Antenna tuning can be automatically performed by sending direct command [Calibrate Antenna](#) or by an algorithm implemented in external controller by performing phase and amplitude measurements and controlling the TRIM switches using [Antenna Calibration Control Register](#).

### ***Antenna Tuning Using Direct Command ‘Calibrate Antenna’***

In order to perform the antenna LC tank using direct command [Calibrate Antenna](#) binary weighted tuning capacitors have to be connected between the two coil terminals to the pins TRIM1\_3 to TRIM1\_0 and TRIM2\_3 to TRIM2\_0.

During automatic procedure, started by sending the direct command [Calibrate Antenna](#), the AS3911B finds position of TRIM switches at which the phase difference between the RFO output signal and RFI input signal is as close as possible to target phase defined in the [Antenna Calibration Target Register](#).

In case the antenna LC tank is directly connected to RFO pins (as in case of [Figure 129](#)) there is 90° phase shift between signal on the RFO outputs and the voltage on the RFI inputs when antenna LC tank is in resonance. In case additional EMC filter is inserted between RFO outputs and antenna LC tank the phase shift in case of resonance depends on additional phase shift generated by EMC filter.

During execution of the direct command [Calibrate Antenna](#) the AS3911B runs several phase measurements and changes configuration of TRIM pins in order to find the best possible setting. Due to this the format of the [Antenna Calibration Target Register](#) is the same as the format of direct command [Measure Phase](#) result.

The TRIM pin configuration which is result of the direct command [Calibrate Antenna](#) can be observed by reading the [Antenna Calibration Display Register](#). This register also contains an error flag which is set in case the tuning to target phase was not possible.

After the execution of direct command [Calibrate Antenna](#) the actual phase can be checked by sending direct command [Measure Phase](#).

**Figure 129:**  
**Connection of Tuning Capacitors to the Antenna LC Tank in Case of Single (left) and Differential Driving (right)**

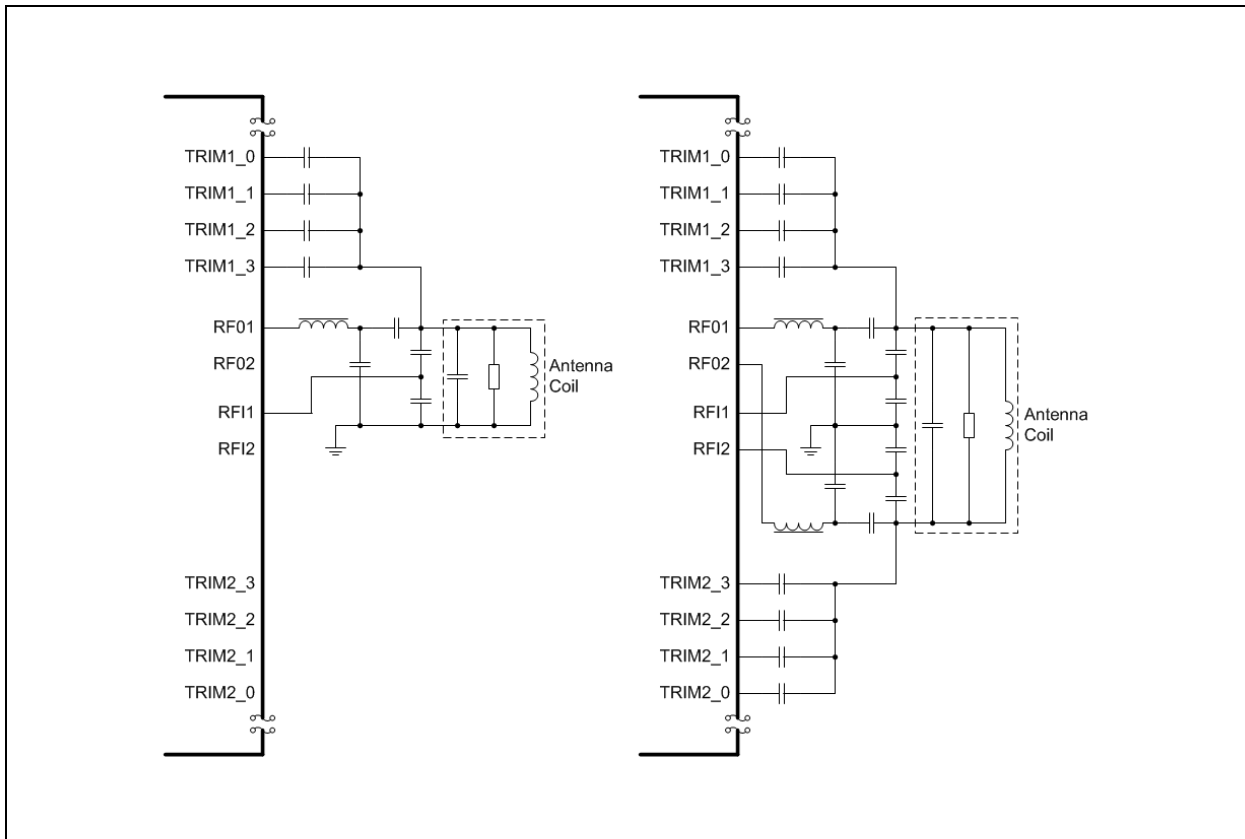

#### **Antenna Tuning Using 'Antenna Calibration Control' Register**

There is also a possibility to control the position of the TRIM switches by writing the [Antenna Calibration Control Register](#). When the bit *trim\_s* of this register is set to 1 position of the trim switches is controlled by bits *tre\_3* to *tre\_0*.

Using this register and performing phase and amplitude measurements (using direct commands [Measure Phase](#) and [Measure Amplitude](#)) different tuning algorithms can be implemented in the external controller.

#### **Stream Mode and Transparent Mode**

Standard and custom 13.56 MHz RFID reader protocols, which are not supported by the AS3911B framing, can be realized using the AS3911B AFE and framing implemented in the external microcontroller.

### **Transparent Mode**

After sending the direct command [Transparent Mode](#) the external microcontroller directly controls the transmission modulator and gets the Receiver output (control logic becomes “transparent”).

The Transparent Mode is entered on rising edge of signal /SS after sending the command [Transparent Mode](#) and is maintained as long as the signal /SS is kept high. Before sending the direct command [Transparent Mode](#) the Transmitter and Receiver have to be turned on, the AFE has to be configured properly.

While the AS3911B is in the Transparent Mode the AFE is controlled directly through SPI interface:

- Transmitter modulation is controlled by pin MOSI (high is modulator on)
- Signal *rx\_on* is controlled by pin SCLK (high enables RSSI and AGC)
- Output of Receiver AM demodulation chain (digitized sub-carrier signal) is sent to pin MISO
- Output of Receiver PM demodulation chain (digitized sub-carrier signal) is sent to pin IRQ

By controlling the *rx\_on* advanced Receiver features like the RSSI and AGC can be used. The receiver channel selection bits are valid also in Transparent mode, therefore it is possible to use only one of the two channel outputs. In case single channel is selected it is always multiplexed to MISO, while IRQ is kept low.

Configuration bits related to the ISO mode, framing and FIFO are of course meaningless in Transparent Mode, all other configuration bits are respected.

#### **Use of Transparent Mode to Implement Active Peer to Peer (NFC) Communication:**

The framing implemented in the AS3911B supports all active modes according to the NFCIP-1 specification (ISO/IEC 18092:2004). In case any amendments to this specification or some custom active NFC communication need to be implemented Transparent mode can be used.

There is no special NFC active communication transparent mode, controlling of the Tx modulation and the Rx is done as described above. The difference comparing to the reader transparent mode is that the emission of the carrier field has to be enabled only during Tx. This is done by writing the [Operation Control Register](#) before and after Tx. Since with every SPI command the Transparent mode is lost it has to be re-entered.

In order to receive the reply in active NFC communication mode only the AM demodulation channel is used. Due to this the Receiver AM channel has to be enabled, while PM can be disabled.

Implementing active communication requires detection of external field. Setting the bit *en\_fd* in the [Auxiliary Definition Register](#) enables the External Field Detector with Peer Detection Threshold. When bit *en\_fd* is selected and the AS3911B is in Transparent mode, the External Field Detector output is multiplexed to pin IRQ. This enables detection of external target/initiator field and performing RF collision avoidance.

In case timing of the *NFC Field ON* command is correct for the NFC active protocol which is being implemented, these commands can be used in combination with the Transparent mode. These commands are used to perform the RF collision avoidance, switching on the field and timing out the minimum time from switching on the field to start of transmitting the message. After getting the interrupt, the controller generates the message in the Transparent mode.

When bit *en\_fd* is set and all bits of the [Operation Control Register](#) are set to 0 the AS3911B is in the low power NFC Target Mode (same as in case of setting of *targ* bit, (see [NFCIP-1 Active Communication Target](#)). In this mode initiator field is detected. After getting an IRQ with *L\_eon* flag set, the controller turns on the oscillator, regulator and receiver and performs reception in the Transparent mode.

### **MIFARE™ Classic Compatibility**

For communication with MIFARE™ Classic compliant devices the bit6 and bit7 from the register 05h can be used to enable Type A custom frames. Alternatively stream mode of AS3911 can be used to send and receive MIFARE™ Classic compliant or custom frames.

### **Stream Mode**

Stream mode can be used to implement protocols, where the low level framing needed for ISO14443 receive coding can be used and decoded information can be put in FIFO. The main advantage of this mode over the Transparent mode is that timing is generated in the AS3911B therefore the external controller does not have to operate in real time. The stream mode is selected in the [Mode Definition Register](#), the operating options are defined in the [Stream Mode Definition Register](#). Two different modes are supported for tag to reader communication (Sub-carrier and BPSK Stream Modes). General rule for Stream mode is that the first bit sent/received is put on the LSB position of the FIFO byte.

After selecting the stream mode the Receiver and Transmitter have to be configured properly (Analog Preset direct command doesn't apply for stream mode).

#### **Sub-Carrier Stream Mode:**

This mode supports protocols where during the tag to reader communication the time periods with sub-carrier signal are interchanged with time periods without modulation (like in the ISO14443A 106 kbit/s mode). In this mode the sub-carrier

frequency and number of sub-carrier frequency periods in one reporting period is defined. Sub-carrier frequency in the range from  $f_c/64$  (212 kHz) to  $f_c/8$  (1695 kHz) are supported.

Supported number of sub-carrier frequency periods in one reporting period range from two to eight.

Start of receive interrupt is sent and the first data bit is put in FIFO after the first reporting time period with sub-carrier is detected. One bit of FIFO data gives information about status of input signal during one reporting period. Logic 1 means that the sub-carrier was detected during reporting period, while 0 means that no modulation was detected during reporting period. End of receive is reported when no sub-carrier signal in more than eight reporting periods have been detected.

Figure below depicts an example for setting  $scf = 01b$  and  $scp = 10b$ . With this setting the sub-carrier frequency is set to  $f_c/32$  (424 kHz) and the reporting period to four sub-carrier periods ( $128/f_c - \sim 106 \mu s$ ).

**Figure 130:**  
Example of Sub-Carrier Stream Mode for  $scf = 01b$  and  $scp = 10b$

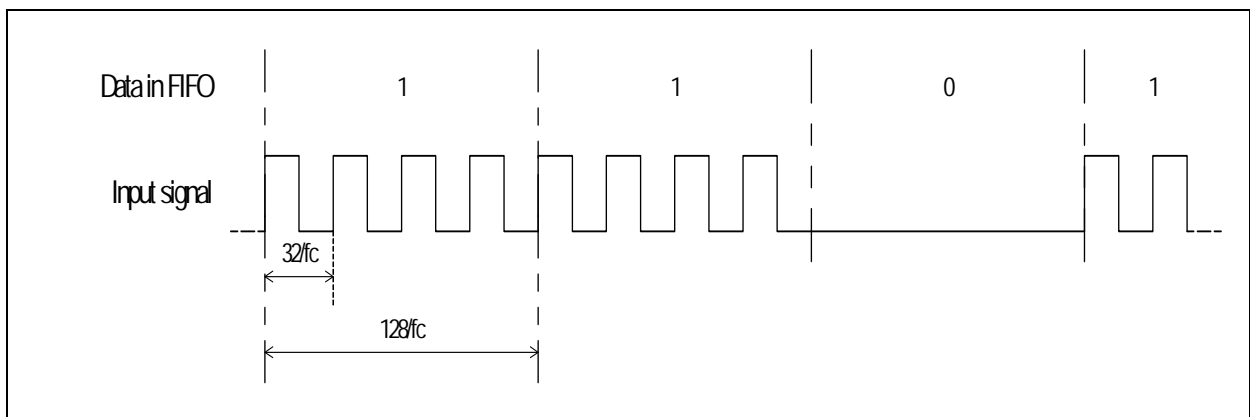

**BPSK Stream Mode:**

This mode supports protocols where during the tag to reader communication BPSK code is used (like in the ISO14443B mode). In this mode the sub-carrier frequency and number of sub-carrier frequency periods in one reporting period is defined. Sub-carrier frequency in the range from  $f_c/16$  (848 kHz) to  $f_c/4$  (3390 kHz) are supported. Supported number of sub-carrier frequency periods in one reporting period range from one to eight.

Start of receive interrupt is sent and the first data bit is put in FIFO after the first reporting time period with sub-carrier is detected. Logic 0 is used for the initially detected phase, while logic 1 indicates inverted phase comparing to the initial phase. End of receive is reported when the first reporting period without sub-carrier is detected.

Figure below depicts an example for setting  $scf = 01b$  and  $scp = 01b$ . With this setting the sub-carrier frequency is set to  $f_c/8$  (1695 kHz) and the reporting period to two sub-carrier periods ( $16/f_c - \sim 1.18 \mu s$ ).



**Figure 131:**  
**Example of BPSK Stream Mode for  $scf = 01b$  and  $scp = 01b$**

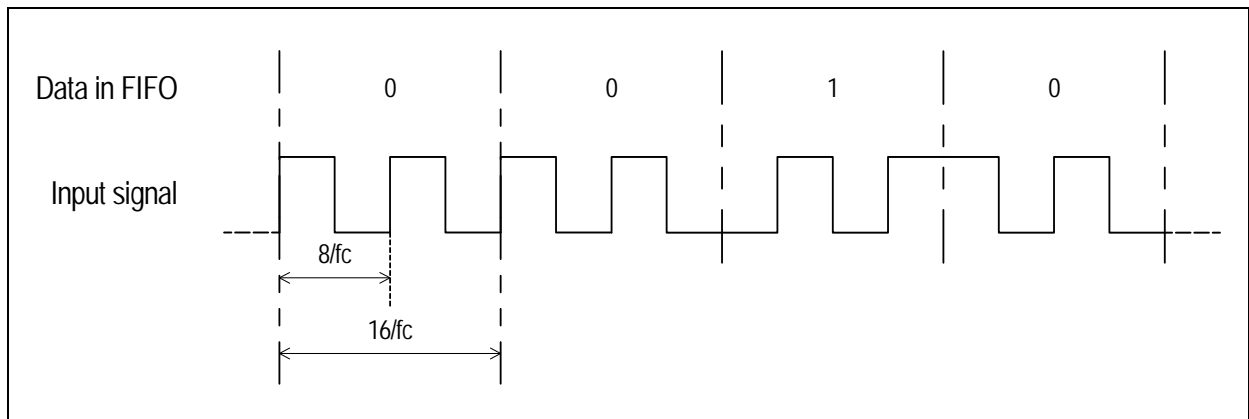

**Reader to Tag Communication in Stream Mode:**

Reader to tag communication control is the same for both stream modes. Reader to tag coding is defined by data put in FIFO. The **stx** bits of [Stream Mode Definition Register](#) define the Tx time period during which one bit of FIFO data define the status of transmitter. In case the data bit is set to logic 0 there is no modulation, in case it is logic 1 the transmitted carrier signal is modulated according to current modulation type setting (AM or OOK). Transmission in stream mode is started by sending direct commands [Transmit Without CRC](#) or [Transmit With CRC](#).

Figure below depicts an example for setting  $stx = 000b$ . With this setting the Tx time period is defined to  $128/fc$  ( $\sim 9,44 \mu s$ ).

**Figure 132:**  
**Example of Tx in Stream Mode for  $stx = 000b$  and OOK Modulation**

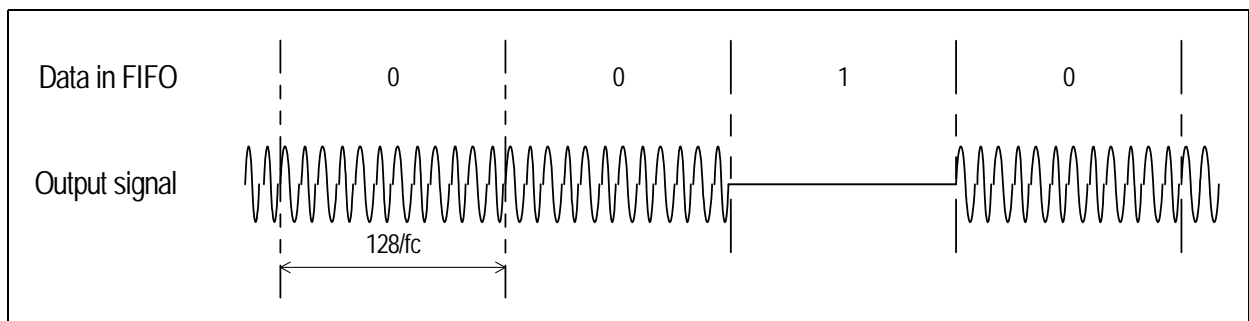

**Package Drawings & Markings**

The device is available in a 32-pin QFN (5x5mm) package.

**Figure 133:**  
Package Drawings

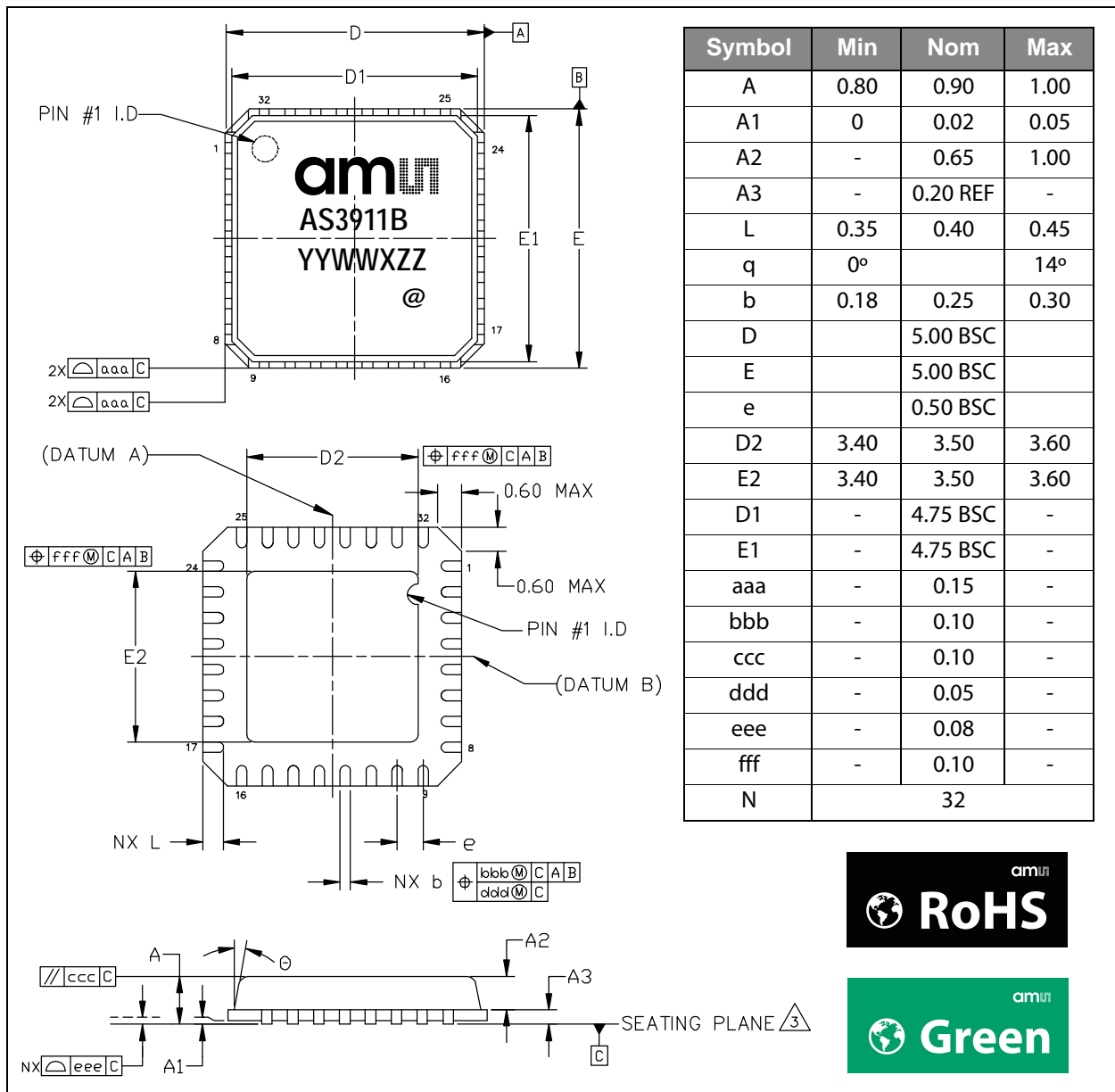

**Note(s) and/or Footnote(s):**

1. Dimensioning and tolerances conform to ASME Y14.5M-1994.
2. All dimensions are in millimeters. Angles are in degrees.
3. Co-planarity applies to the exposed heat slug as well as the terminal.
4. Radius on terminal is optional.
5. N is the total number of terminals.
6. This drawing is subject to change without notice.

**Figure 134:**  
Marking YYWWXZZ

YY	WW	X	ZZ	@
Year	Manufacturing week	Plant Identifier	Traceability code	Sublot Identifier

## Ordering & Contact Information

**Figure 135:**  
Ordering Information

Ordering Code	Type	Marking	Delivery Form
AS3911B-AQFT	Packaged 32-pin QFN (5x5mm)	AS3911B	Tape & Reel
AS3911B-ASWB	Sorted wafer	n.a.	Wafer Box

Buy our products or get free samples online at:

[www.ams.com/ICdirect](http://www.ams.com/ICdirect)

Technical Support is available at:

[www.ams.com/Technical-Support](http://www.ams.com/Technical-Support)

Provide feedback about this document at:

[www.ams.com/Document-Feedback](http://www.ams.com/Document-Feedback)

For further information and requests, e-mail us at:

[ams\\_sales@ams.com](mailto:ams_sales@ams.com)

For sales offices, distributors and representatives, please visit:

[www.ams.com/contact](http://www.ams.com/contact)

### Headquarters

ams AG

Tobelbaderstrasse 30

8141 Premstaetten

Austria, Europe

Tel: +43 (0) 3136 500 0

Website: [www.ams.com](http://www.ams.com)

## RoHS Compliant & ams Green Statement

**RoHS:** The term RoHS compliant means that ams AG products fully comply with current RoHS directives. Our semiconductor products do not contain any chemicals for all 6 substance categories, including the requirement that lead not exceed 0.1% by weight in homogeneous materials. Where designed to be soldered at high temperatures, RoHS compliant products are suitable for use in specified lead-free processes.

**ams Green (RoHS compliant and no Sb/Br):** ams Green defines that in addition to RoHS compliance, our products are free of Bromine (Br) and Antimony (Sb) based flame retardants (Br or Sb do not exceed 0.1% by weight in homogeneous material).

**Important Information:** The information provided in this statement represents ams AG knowledge and belief as of the date that it is provided. ams AG bases its knowledge and belief on information provided by third parties, and makes no representation or warranty as to the accuracy of such information. Efforts are underway to better integrate information from third parties. ams AG has taken and continues to take reasonable steps to provide representative and accurate information but may not have conducted destructive testing or chemical analysis on incoming materials and chemicals. ams AG and ams AG suppliers consider certain information to be proprietary, and thus CAS numbers and other limited information may not be available for release.

## Copyrights & Disclaimer

Copyright ams AG, Tobelbader Strasse 30, 8141 Premstaetten, Austria-Europe. Trademarks Registered. All rights reserved. The material herein may not be reproduced, adapted, merged, translated, stored, or used without the prior written consent of the copyright owner.

Devices sold by ams AG are covered by the warranty and patent indemnification provisions appearing in its General Terms of Trade. ams AG makes no warranty, express, statutory, implied, or by description regarding the information set forth herein. ams AG reserves the right to change specifications and prices at any time and without notice. Therefore, prior to designing this product into a system, it is necessary to check with ams AG for current information. This product is intended for use in commercial applications. Applications requiring extended temperature range, unusual environmental requirements, or high reliability applications, such as military, medical life-support or life-sustaining equipment are specifically not recommended without additional processing by ams AG for each application. This product is provided by ams AG "AS IS" and any express or implied warranties, including, but not limited to the implied warranties of merchantability and fitness for a particular purpose are disclaimed.

ams AG shall not be liable to recipient or any third party for any damages, including but not limited to personal injury, property damage, loss of profits, loss of use, interruption of business or indirect, special, incidental or consequential damages, of any kind, in connection with or arising out of the furnishing, performance or use of the technical data herein. No obligation or liability to recipient or any third party shall arise or flow out of ams AG rendering of technical or other services.

### Legal Notice:

Capacitive wakeup feature is covered by patent US6150948 (LOW-POWER RADIO FREQUENCY IDENTIFICATION READER) for which ams AG is exclusive licensee including, not limited to copyrights, patents, trademarks and trade secrets related thereto.

Purchase of ams AG ICs with MIFARE Classic™ compatibility:

This ams AG IC offers modes to be compatible with MIFARE™ Classic RFID tags. This allows to build MIFARE™ Classic compatible reader systems. MIFARE™ and MIFARE™ Classic are trademarks of NXP B.V., High Tech Campus 60 NL-5656 AG EINDHOVEN, NL. Purchase of ams AG's MIFARE™ Classic compatible products does not provide a license of any NXP rights, in particular does not provide the right to use MIFARE™ or MIFARE™ Classic as a trademark to brand such systems.

Purchase of ams AG's ICs with ISO/IEC 14443 type B functionality:

This ams AG IC is ISO/IEC 14443 Type B software enabled and is licensed under Innovatron's Contactless Card patents license for ISO/IEC 14443 B. The license includes the right to use the IC in systems and/or end-user equipment.

## Document Status

Document Status	Product Status	Definition
Product Preview	Pre-Development	Information in this datasheet is based on product ideas in the planning phase of development. All specifications are design goals without any warranty and are subject to change without notice
Preliminary Datasheet	Pre-Production	Information in this datasheet is based on products in the design, validation or qualification phase of development. The performance and parameters shown in this document are preliminary without any warranty and are subject to change without notice
Datasheet	Production	Information in this datasheet is based on products in ramp-up to full production or full production which conform to specifications in accordance with the terms of ams AG standard warranty as given in the General Terms of Trade
Datasheet (discontinued)	Discontinued	Information in this datasheet is based on products which conform to specifications in accordance with the terms of ams AG standard warranty as given in the General Terms of Trade, but these products have been superseded and should not be used for new designs

## Revision Information

Changes from 1-14 (2015-Nov-23) to current revision 1-15 (2016-Jun-10)	Page
Updated Figure 9	9
Updated text above Figure 16	22
Updated text under AGC	24
Updated EQ1	29
Updated text under Transmit Commands	53

**Note(s) and/or Footnote(s):**

1. Page and figure numbers for the previous version may differ from page and figure numbers in the current revision.
2. Correction of typographical errors is not explicitly mentioned.

## Content Guide

<b>1</b>	<b>General Description</b>
2	Key Benefits & Features
3	Applications
3	Block Diagram
<b>4</b>	<b>Pin Assignment</b>
<b>7</b>	<b>Absolute Maximum Ratings</b>
<b>8</b>	<b>Electrical Characteristics</b>
8	Operating Conditions
8	DC/AC Characteristics for Digital Inputs and Outputs
8	CMOS Inputs:
9	CMOS Outputs:
9	Electrical Specification
<b>12</b>	<b>Typical Operating Characteristics</b>
12	Thermal Resistance and Max. Power Dissipation
<b>13</b>	<b>Detailed Description</b>
14	Transmitter
14	Receiver
14	Phase and Amplitude Detector
14	A/D Converter
15	Capacitive Sensor
15	External Field Detector
15	Quartz Crystal Oscillator
15	Power Supply Regulators
16	POR and Bias
16	RC Oscillator and Wake-up Timer
16	ISO14443 and NFCIP-1 Framing
16	FIFO
16	Control Logic
16	SPI Interface
<b>17</b>	<b>Application Information</b>
17	Operating Modes
17	Transmitter
19	Slow Transmitter Ramping
19	Receiver
20	Demodulation Stage
21	Filtering and Gain Stages
23	Digitizing Stage
24	AGC, Squelch and RSSI
25	Receiver in NFCIP-1 Active Communication Mode
26	Capacitive Sensor
27	Capacitor Sensor Calibration
28	Wake-Up Mode
29	Auto-Averaging
30	Quartz Crystal Oscillator
30	Timers
31	Mask Receive Timer and No-Response Timer
32	General Purpose Timer
32	Wake-Up Timer
33	A/D Converter



<b>33</b>	<b>Phase and Amplitude Detector</b>
33	Phase Detector
34	Amplitude Detector
<b>35</b>	<b>External field Detector</b>
35	Peer Detection Threshold
35	Collision Avoidance Threshold
<b>36</b>	<b>Power Supply System</b>
38	VSP_RF Regulator
39	VSP_A and VSP_D Regulators
39	Power-Down Support Block
39	Measurement of Supply Voltages
<b>40</b>	<b>Communication to External Microcontroller</b>
40	Serial Peripheral Interface (SPI)
42	Writing of Data to Addressable Registers (Write Mode)
43	Reading of Data from Addressable Registers (Read Mode)
43	Loading Transmitting Data into FIFO
44	Reading Received Data from FIFO
45	Direct Command Mode
45	Direct Command Chaining
46	SPI Timing
47	Interrupt Interface
48	FIFO Water Level and FIFO Status Registers
49	Pin MCU_CLK
<b>50</b>	<b>Direct Commands</b>
53	Set Default
53	Clear
53	Transmit Commands
54	NFC Field ON Commands
55	Go to Normal NFC Mode
55	Analog Preset
57	Mask Receive Data and Unmask Receive Data
57	Measure Amplitude
57	Squelch
58	Reset Rx Gain
58	Adjust Regulators
59	Calibrate Modulation Depth
59	Calibrate Antenna
59	Measure Phase
60	Clear RSSI
60	Transparent Mode
60	Calibrate Capacitive Sensor
61	Measure Capacitance
61	Measure Power Supply
<b>61</b>	<b>Start Timers</b>
<b>61</b>	<b>Test Access</b>
61	Test Mode Entry and Access to Test Registers
<b>63</b>	<b>Registers</b>
67	IO Configuration Register 1
68	IO Configuration Register 2
69	Operation Control Register
70	Mode Definition Register
71	Bit Rate Definition Register

72	ISO14443A and NFC 106kb/s Settings Register
74	ISO14443B Settings Register 1
75	ISO14443B and FeliCa Settings Register
76	Stream Mode Definition Register
78	Auxiliary Definition Register
79	Receiver Configuration Register 1
80	Receiver Configuration Register 2
81	Receiver Configuration Register 3
82	Receiver Configuration Register 4
83	Mask Receive Timer Register
83	No-Response Timer Register 1
84	No-Response Timer Register 2
84	General Purpose and No-Response Timer Control Register
86	General Purpose Timer Register 1
86	General Purpose Timer Register 2
87	Mask Main Interrupt Register
87	Mask Timer and NFC Interrupt Register
88	Mask Error and Wake-Up Interrupt Register
89	Main Interrupt Register
90	Timer and NFC Interrupt Register
91	Error and Wake-Up Interrupt Register
92	FIFO Status Register 1
93	FIFO Status Register 2
94	Collision Display Register
95	Number of Transmitted Bytes Register 1
95	Number of Transmitted Bytes Register 2
96	NFCIP Bit Rate Detection Display Register
96	A/D Converter Output Register
97	Antenna Calibration Control Register
98	Antenna Calibration Target Register
98	Antenna Calibration Display Register
99	AM Modulation Depth Control Register
100	AM Modulation Depth Display Register
100	RFO AM Modulated Level Definition Register
101	RFO Normal Level Definition Register
101	External Field Detector Threshold Register
104	Regulator Voltage Control Register
105	Regulator and Timer Display Register
107	RSSI Display Register
109	Gain Reduction State Register
110	Capacitive Sensor Control Register
111	Capacitive Sensor Display Register
111	Auxiliary Display Register
112	Wake-Up Timer Control Register
113	Amplitude Measurement Configuration Register
114	Amplitude Measurement Reference Register
114	Amplitude Measurement Auto-Averaging Display Register
115	Amplitude Measurement Display Register
116	Phase Measurement Configuration Register
117	Phase Measurement Reference Register
117	Phase Measurement Auto-Averaging Display Register
118	Phase Measurement Display Register

119	Capacitance Measurement Configuration Register
120	Capacitance Measurement Reference Register
120	Capacitance Measurement Auto-Averaging Display Register
121	Capacitance Measurement Display Register
121	IC Identity Register
122	Power-Up Sequence
122	Reader Operation
123	Anticollision – ISO 14443A
125	Setting up AS3911B for ISO 14443A Anticollision
126	REQA and WUPA
127	ANTICOLLISION Procedure
129	FeliCa Reader Mode
129	FeliCa Transmission
129	FeliCa Reception
129	NFCIP-1 Operation
130	NFCIP-1 Passive Communication Initiator
132	NFCIP-1 Active Communication Initiator
134	NFCIP-1 Active Communication Target
136	AM Modulation Depth: Definition and Calibration
137	AM Modulation Depth Definition Using the ‘Calibrate Modulation Depth’ Direct Command
138	AM Modulation Depth Definition using the ‘RFO AM Modulated Level Definition’ Register
139	Antenna Tuning
140	Antenna Tuning Using Direct Command ‘Calibrate Antenna’
141	Stream Mode and Transparent Mode
142	Transparent Mode
143	MIFARE™ Classic Compatibility
143	Stream Mode
<b>146</b>	<b>Package Drawings &amp; Markings</b>
<b>147</b>	<b>Ordering &amp; Contact Information</b>
<b>148</b>	<b>RoHS Compliant &amp; ams Green Statement</b>
<b>149</b>	<b>Copyrights &amp; Disclaimer</b>
<b>150</b>	<b>Document Status</b>
<b>151</b>	<b>Revision Information</b>

## X-ON Electronics

Largest Supplier of Electrical and Electronic Components

*Click to view similar products for [RFID Transponders](#) category:*

*Click to view products by [ams](#) manufacturer:*

Other Similar products are found below :

[PCF7941ATSM2AB120](#), [NT2H0301F0DTL,125](#) [SL2S1512FTBX](#) [AT88SC0808CRF-MX1](#) [HT2DC20S20/F/RSP](#) [V680S-A40 50M](#)  
[NT3H1201W0FTTJ](#) [PN7120A0EV/C10801Y](#) [TRPGP40ATGC](#) [TRPGR30ATGA](#) [M24LR04E-RMC6T2](#) [P5DF081HN/T1AR1070](#)  
[SPS1M003B](#) [SPS1M003A](#) [SPS1M002B](#) [SPS1M002A](#) [V680S-HMD64-ETN](#) [V680S-A40 10M](#) [V680S-A41 10M](#) [V680-D1KP66T](#)  
[PCF7946AT/1081/CM](#) [ATA5577M2330C-DBQ](#) [AS3930-BTST](#) [CLRD710,599](#) [PCF7938XA/CAAB3800](#) [ST25DV64K-JFR6D3](#) [V680S-](#)  
[HMD66-ETN](#) [ST25DV04K-JFR6D3](#) [AT88RF04C-MVA1](#) [ST25DV16K-JFR6D3](#) [NVT4857UKAZ](#) [NT2H1611G0DA8J](#) [LXMSANAA19-181](#)  
[PCF7936AA/3851/C/6](#) [KH-RFID-4216-BQ](#) [KH-RFID-7023-BQ](#) [KH-RFID-8046-BQ](#) [60208](#) [60170](#) [PN7150B0HN/C11006Y](#)  
[PN7150B0HN/C11006E](#) [RF-HDT-DVBB-N2](#) [SRTAG2K-DMC6T/2](#) [TRPGR30ATGB](#) [PN5120A0HN1/C2,157](#) [RF37S114HTFJB](#)  
[MF3MOD4101DA4/05,1](#) [MAX1473EUI+T](#) [NRF51822-QFAA-R](#) [28340](#)