



austriamicrosystems AG

is now

ams AG

The technical content of this austriamicrosystems application note is still valid.

Contact information:

Headquarters:

ams AG

Tobelbaderstrasse 30

8141 Unterpremstaetten, Austria

Tel: +43 (0) 3136 500 0

e-Mail: ams_sales@ams.com

Please visit our website at www.ams.com

1 General Description

The AS5030 is a contactless magnetic rotary encoder for accurate angular measurement over a full turn of 360°. It is a system-on-chip, combining integrated Hall elements, analog front end and digital signal processing in a single device.

To measure the angle, only a simple two-pole magnet, rotating over the center of the chip is required.

The absolute angle measurement provides instant indication of the magnet's angular position with a resolution of 8 bit = 256 positions per revolution. This digital data is available as a serial bit stream and as a PWM signal.

In addition to the angle information, the strength of the magnetic field is also available as a 6-bit code.

Data transmission can be configured for 1-wire (PWM), 2-wires (CLK, DIO) or 3-wires (CLK, DIO, CS).

A software programmable (OTP) zero position simplifies assembly as the zero position of the magnet does not need to be mechanically aligned.

A Power Down Mode together with fast startup- and measurement cycles allows for very low average power consumption and makes the AS5030 also suitable for battery operated equipment.

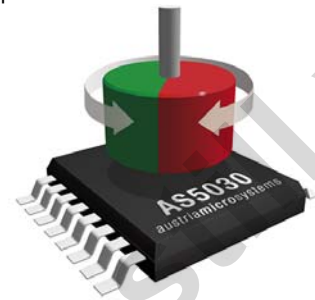

2 The AS5030 Adapterboard

2.1 Board description

The AS5030 adapter board is a simple circuit allowing to test and evaluate the AS5030 rotary encoder quickly without having to build a test fixture or PCB.

The PCB can be used as standalone unit or attached to a microcontroller.

The standalone operation requires only a 5V power supply, the magnet's angle can be read on the PWM or analog output.

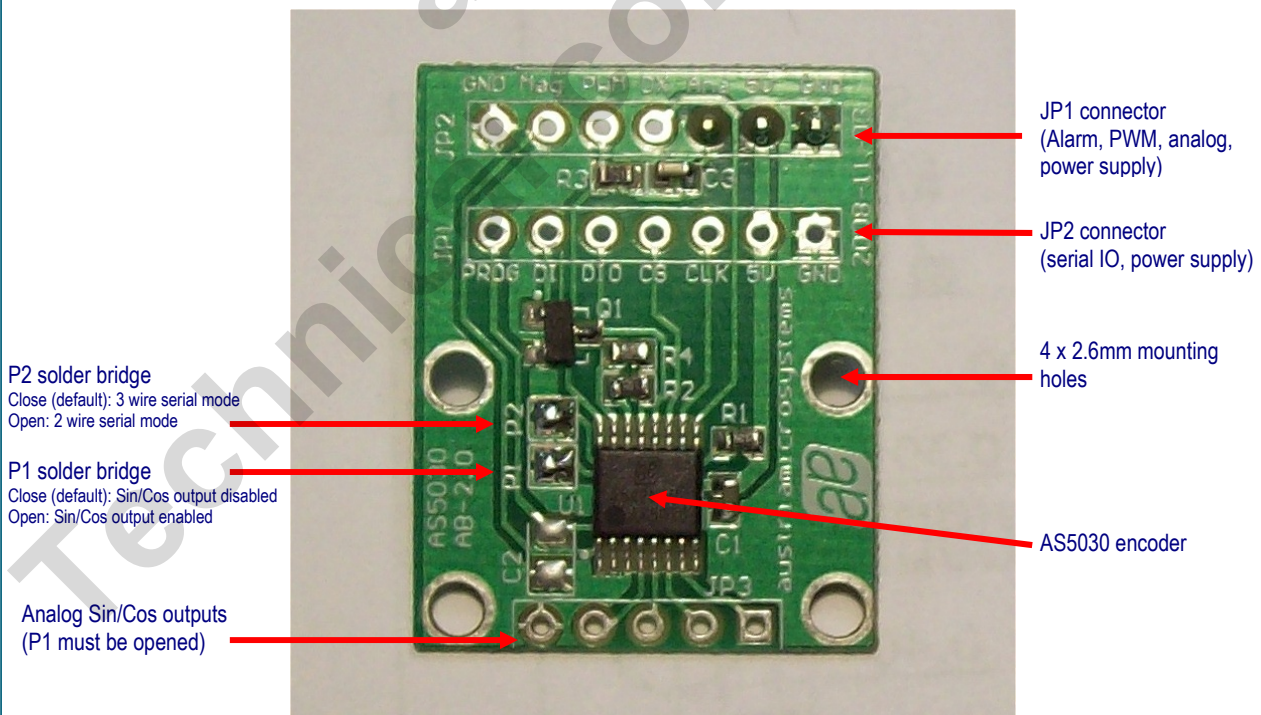

Figure 1: AS5030 Adapterboard

2.2 Mounting the AS5030 adapter board

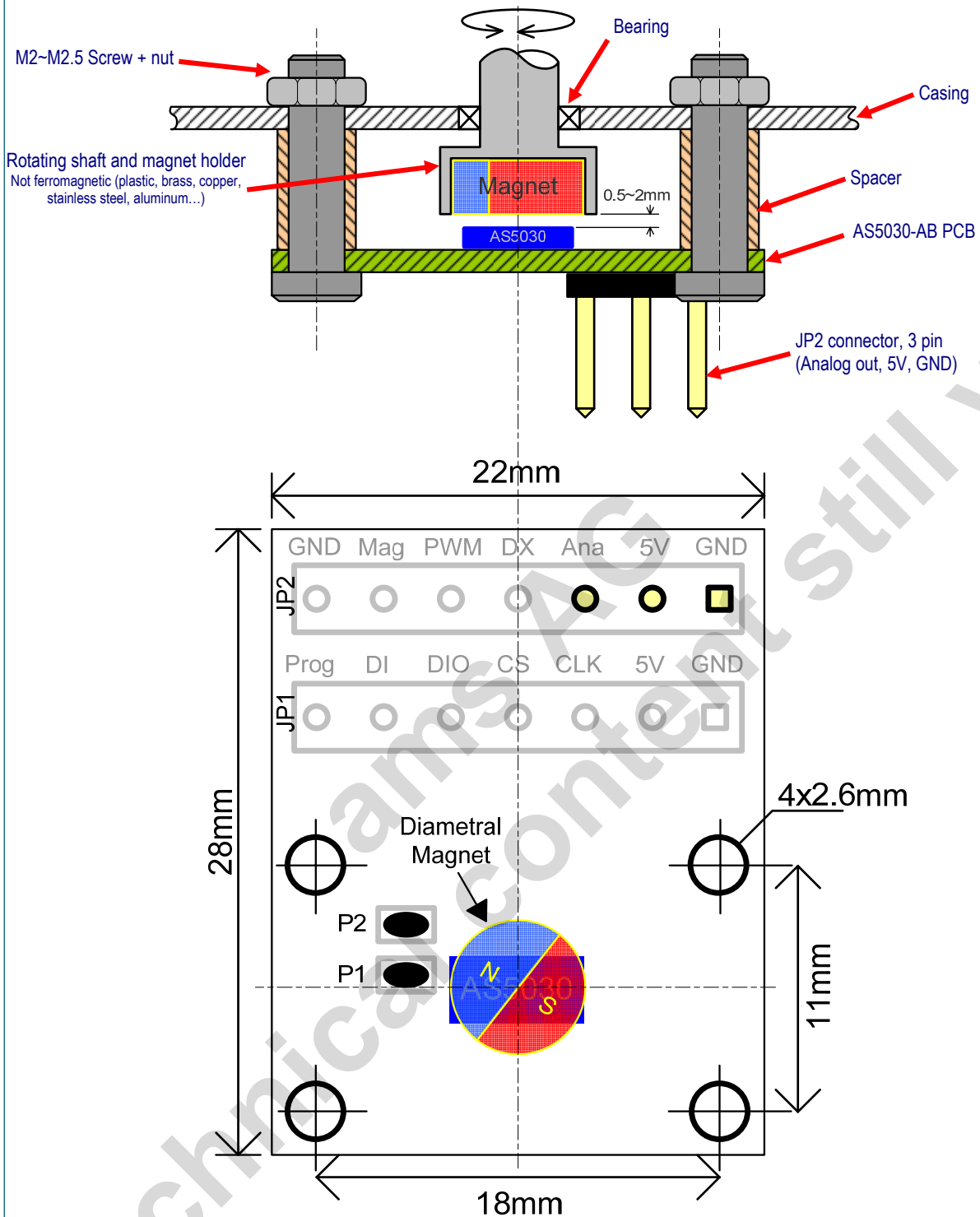

Figure 2: AS5030 adapter board mounting and dimension

A 6x2.5mm diametral magnet must be placed over on under the AS5030, and should be centered on the middle of the package with a tolerance of 0.5mm.

The airgap between the magnet and the AS5030 casing should be maintained in the range 0.5mm~2mm.

The magnet holder must not be ferromagnetic. Materials as brass, copper, aluminum, stainless steel are the best choices to make this part.

3 AS5030 and adapter board pinout

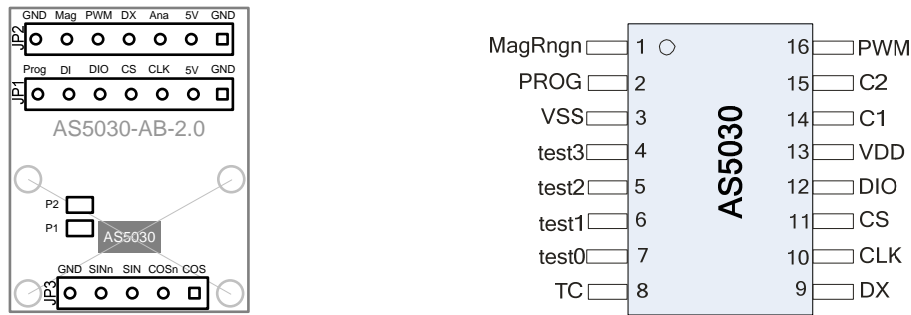

Figure 3: AS5030 adapter board connectors and encoder pinout

Pin# Board	Pin# AS5030	Symbol	Type	Description
JP1 - 1	3	GND	S	Supply ground
JP1 - 2	13	5V	S	Positive supply voltage, 4.5V to 5.5V
JP1 - 3	10	CLK	DI_ST	Clock Input of Synchronous Serial Interface; Schmitt-Trigger input
JP1 - 4	11	CS	DI_ST	Chip Select for serial data transmission, active high; Schmitt-Trigger input, external pull-down resistor (~50kΩ) required in read-only mode
JP1 - 5	12	DIO	DIO	Data output / command input for digital serial interface
JP1 - 6	-	DI	DI	Command input for digital serial interface. Connect to GND if not used.
JP1 - 7	2	PROG	S	OTP Programming voltage supply pin. Leave open or connect to VDD if not used
JP2 - 1	3	GND	S	Supply ground
JP2 - 2	13	5V	S	Positive supply voltage, 4.5V to 5.5V
JP2 - 3	-	Analog	-	0~5V analog output. Generated by the PWM output and filtered.
JP2 - 4	9	DX	DO	Digital output for 2-wire operation and Daisy Chain mode
JP2 - 5	16	PWM	DO	Pulse Width Modulation output, 2.26μs pulse width per step (2.26μs ~ 512μs)
JP2 - 6	1	MagRNG	DO_T	Push-Pull output. Is HIGH when the magnetic field strength is too weak, e.g. due to missing magnet
JP2 - 7	3	GND	S	Supply ground
JP3 - 1	7	COS	-	Must be left unconnected for normal operation. COS output in SIN/COS mode (P1 open)
JP3 - 2	6	COSn	-	Must be left unconnected for normal operation. COSn output in SIN/COS mode (P1 open)
JP3 - 3	5	SIN	-	Must be left unconnected for normal operation. SIN output in SIN/COS mode (P1 open)
JP3 - 4	4	SINn	-	Must be left unconnected for normal operation. SINn output in SIN/COS mode (P1 open)
JP3 - 5	3	GND	S	Supply ground
P1 bridge	14	C1	DI	Configuration input for Sin/Cos output: - Connect to VSS for normal operation (P1 closed, by default) - High level (P1 open) to enable Sin/Cos outputs This pin is scanned at power-on-reset and at wakeup from one of the Ultra Low Power Modes
P2 bridge	15	C2	DI	Configuration input for serial wire mode: - Connect to VSS for 3-wire operation (P2 closed, by default) - High level (P2 open) for 2-wire operation This pin is scanned at power-on-reset and at wakeup from one of the Ultra Low Power Modes

Table 1: Pin description

Pin types: S: supply pin
 DI_ST: digital input / Schmitt-Trigger
 DIO: bi-directional digital pin
 DO: digital output
 DO_T: digital output / tri-state
 DI: digital input (standard CMOS; no pull-up or pull-down)

4 Operation use cases

4.1 Standalone Analog output mode

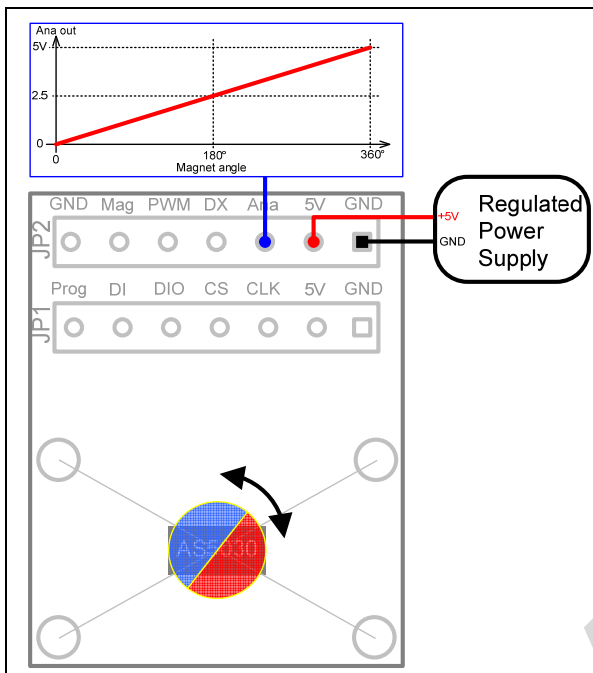

Figure 4: Using the analog output with the adapter board

The simplest setup to test the AS5030 is to use the adapter board in standalone mode. A 3-pin header connector is present on JP2.

A header connector is present on JP2 on pin 1, 2, 3. Connect a regulated power supply on 5V (pin #2) and GND (pin #1).

The “Ana” (pin #3) is an analog output, which is an RC filtered signal of the PWM output of the AS5030. The external device (AD converter, voltmeter...) connected on the “Ana” pin should have an input impedance >470kΩ, otherwise it should be buffered with an op. amp.

By rotating the magnet, a progressive analog voltage from 0 to 5V can be measured on the “Ana” pin (JP2 #3). Rotating the magnet clock wise (AS5030 chip on the top side) increases the Ana voltage, and counter clockwise will decrease the voltage.

Because of the RC filter, the response time of a jump 359° → 0° (5V → 0V) and 0° → 359° (0V → 5V) is 100ms.

4.2 Standalone PWM output mode

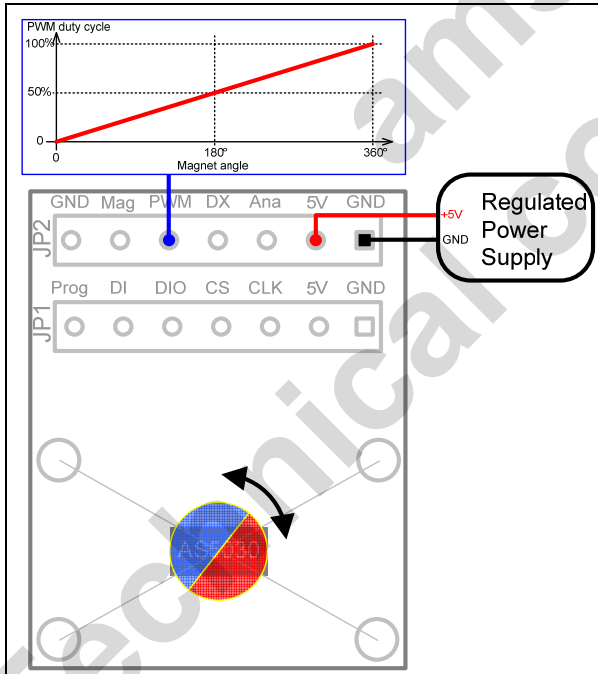

Figure 5: Using the PWM output with the adapter board

Instead of getting a proportional analog voltage increasing with the magnet’s angle on the “Ana” output, a PWM signal (JP2 pin #5) with a period of 581us, 2.26us step and 5V pulse voltage can be connected to the capture/timer input of a microcontroller in order to decode the angle value.

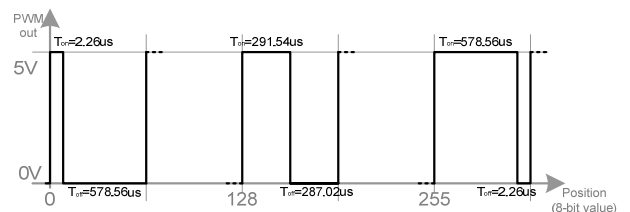

Figure 6: PWM duty cycle depending on magnet position

5 Using the serial interface with MCU

The most complete and accurate solution for a MCU to read the angle of a magnet is the serial interface. The 8 bit value of the angle will be directly read, and some other indicators as AGC value or alarm bits can be read at the same time.

Serial commands can be sent to the AS5030 as well, like the low power mode, lock AGC or reset.

Note: The MCU must have 5V I/O connected to the AS5030 adapter board, the AS5030 is a 5V device.

The connection between the MCU and the adapter board can be made with 2, 3 or 4 wires.

5.1 2-wire serial interface

Jumper configuration: P1 close, P2 open.

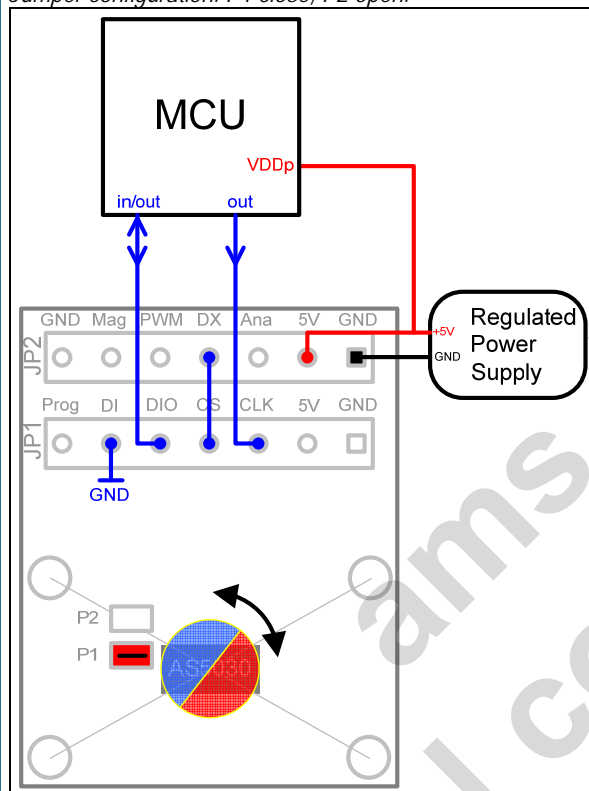

Figure 7: Bidirectional serial connection (2 wire)

By opening P2, the AS5030 is configured to 2-wire data transmission mode. Only Clock (CLK) and Data (DIO) signals are required. A Chip Select (CS) signal is automatically generated by the DX output, when a time-out of CLK occurs (typ. 20µs).

See AS5030 datasheet chapter 4.15.

5.2 3-wire serial interface

Jumper configuration: P1 and P2 close.

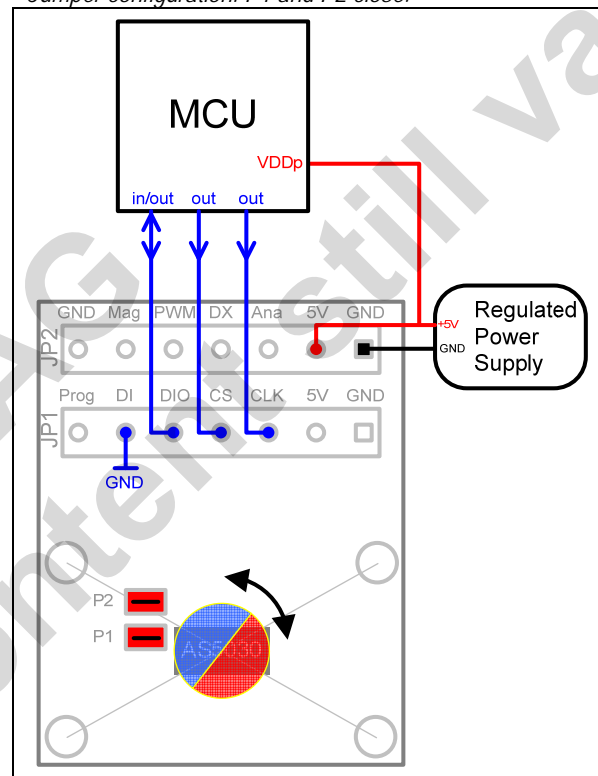

Figure 8: Bidirectional serial connection (3 wire)

The MCU GPIO used for the DIO data signal should be bi-directional: the MCU sends a 5 bit command first then receives a 16 bit value on the same line. The DI input of the adapter board must be connected to GND in this mode.

The C source code for reading an angle with this hardware configuration is described in *Chapter 7*.

5.3 4-wire serial interface

Jumper configuration: P1 and P2 close.

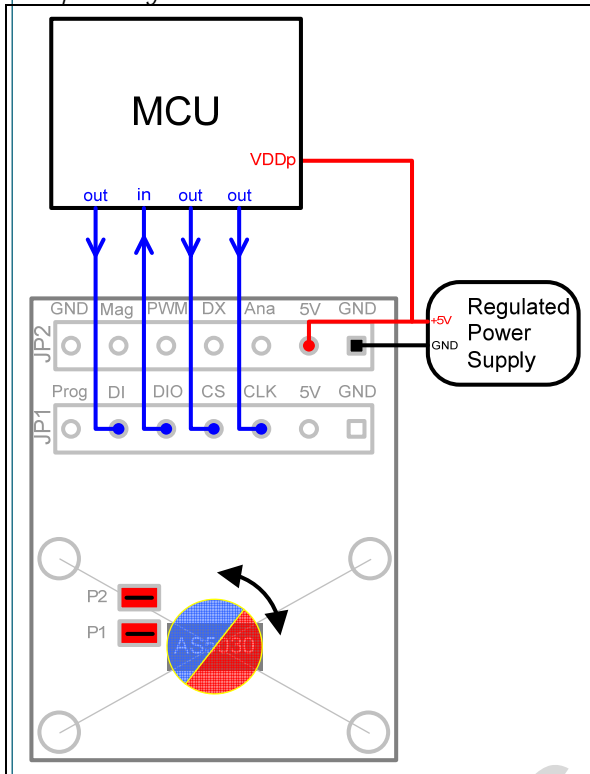

Figure 9: Bidirectional serial connection (4 wire)

The command line and data line are separated:
The command line is a MCU output connected to DI, the data line is an input of the MCU connected to DIO.

With this configuration, synchronous blocks like SPI can be easily used to receive the 16 bit data value from the AS5030. This communication method simplifies the firmware code as well.

5.4 Serial daisy chain mode

Jumper configuration: P1 and P2 close.

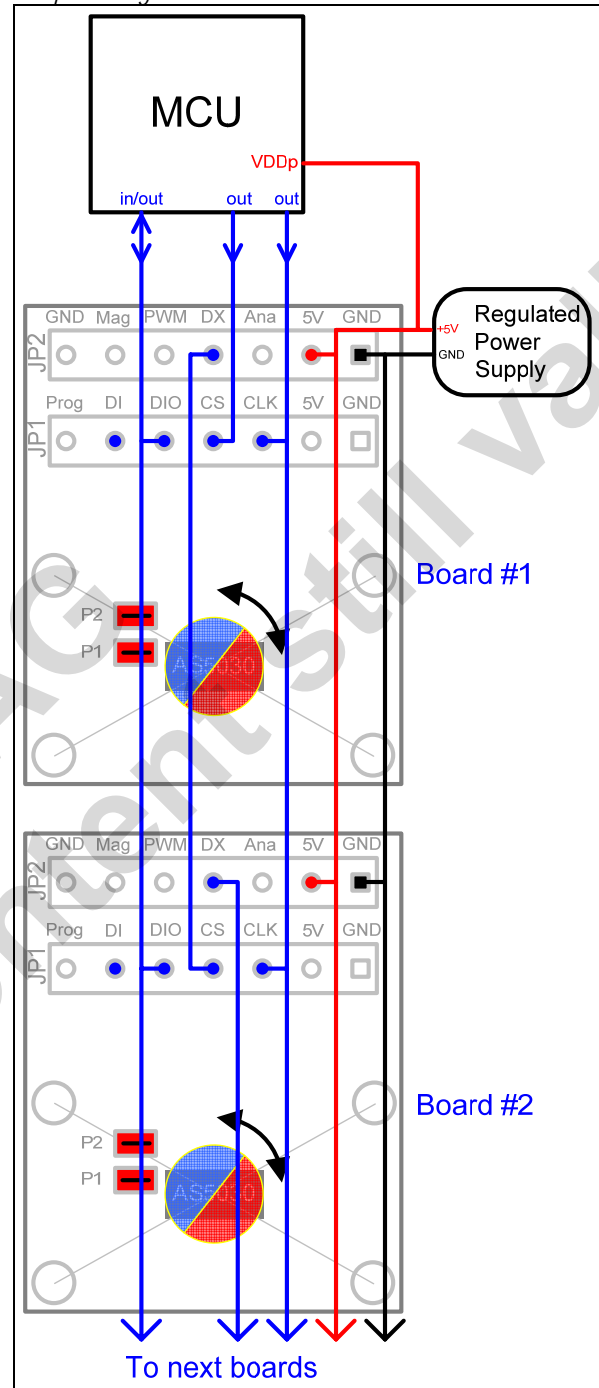

Figure 10: Daisy chain setup (3 wire)

The Daisy Chain mode allows connection of more than one AS5030 to the same MCU. Independent of the number of connected devices, the interface to the controller remains the same with only three signals: CS_n, CLK and DO. In Daisy Chain mode, the data from the second and subsequent devices is appended to the data of the first device.

See AS5030 datasheet chapter 4.21.

6 AS5030 adapterboard hardware

6.1 AS5030-AB-2.0 schematics

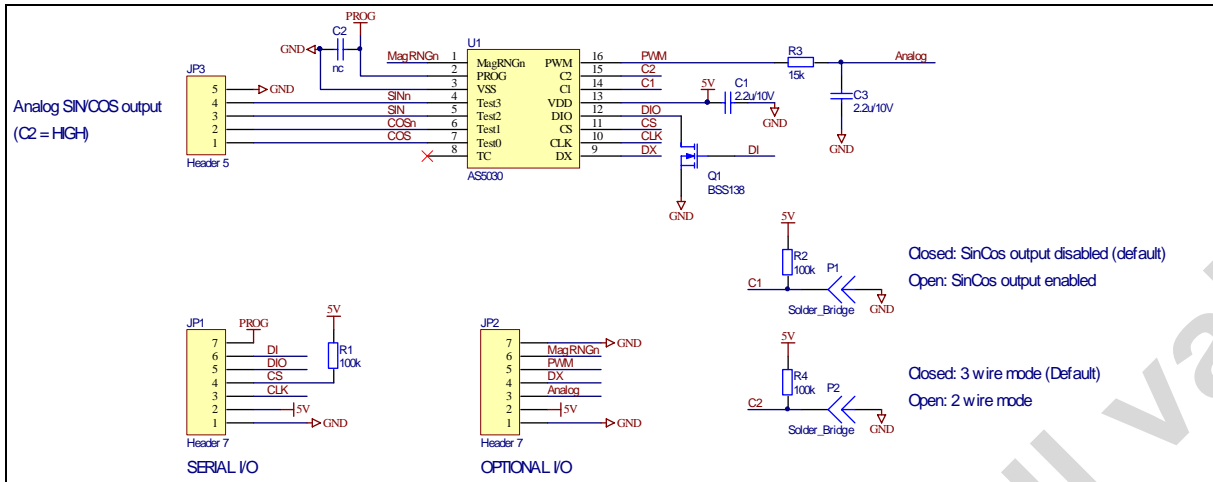

Figure 11: AS5030-AB-2.0 adapterboard schematics

6.2 AS5030-AB-2.0 PCB layout

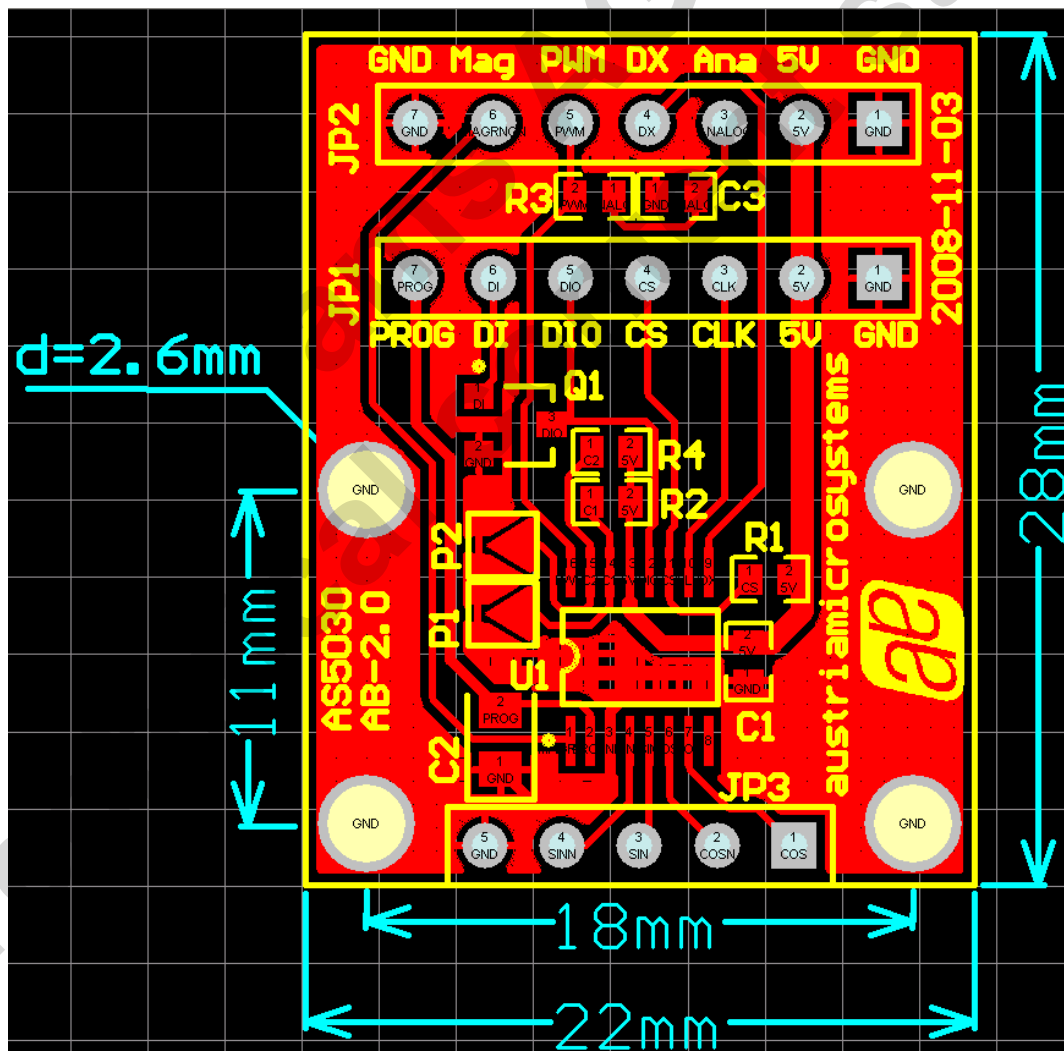

Figure 12: AS5030-AB-2.0 adapterboard layout

7 C-Source code, simple AGC & Angle read

```

void main()    // This program reads the angle and AGC value from AS5030
{
    short SSI_Stream;           // 16-bit value where the serial result will be saved
    byte angle_value, agc_value; // 8-bit results: Angle and AGC
    float angle_degree;        // Angle in degree

    SSI_Stream = SerialRead (0); // Send command "READ" (command '00000')
                                // and reads the 16-bit result from AS5030
    angle_value = (byte)(SSI_Stream & 0x00FF); // Extract the angle value (8 bit)
    agc_value = (byte)((SSI_Stream >> 8) & 0x3F); // Extract the AGC value (6 bit)
    angle_degree = (float)angle_value * (360/256); // Convert the 8-bit angle to degrees (0-360°)
}

short SerialRead(unsigned char command) // This function writes the command
                                        // and receives the result from the AS5030
{
    short RX_buffer;

    SET_CS(); // CS pin = '1', AS5030 selected
    delay_us(Delay_Serial);
    SSIwrite(command); // Send the command (exemple "READ" command '00000')

    DIO_HIGH_IMP(); // DIO output high impedance (input mode), ready to read
    RX_buffer = SSIread(); // Receive the 16bit result from the AS5030

    delay_us(Delay_Serial);
    CLEAR_CS(); // CS pin = '0'

    return RX_buffer;
}

short void SSIread() // This function reads the 16-bit value from the AS5030 DIO pin
{
    xdata unsigned char current_bit;
    short result;

    result = 0; // Is the shift buffer for the 16 bit data receive
    for (current_bit = 16; current_bit; current_bit--) // 16 steps loop (16 bit data)
    {
        result <<= 1; // Shift buffer value left 1 step (first time doesn't count)

        delay_us(Delay_Serial); // Small delay to be get the correct level on DIO
        result += (VAL_DIO) ? 1 : 0; // If '1' on DIO, store '1' on the LSB else '0'

        SET_CLK(); // Generate a CLK pulse to shift the data on DIO
        delay_us(Delay_Serial);
        CLEAR_CLK();
    }
    return result;
}

void SSIwrite(unsigned char command) // This function writes the 5-bit command to
                                     // the AS5030 DIO pin
{
    unsigned char current_bit;
    unsigned char this_bit

    for (current_bit = 5; current_bit; current_bit--) // 5 steps loop (5 bit command)
    {
        this_bit = (command >> (current_bit-1)) & 0x01; // Value of bit 5, then
                                                         // bit 4, ..., bit 0

        // If the current command bit is '1':
        if (this_bit) SET_DIO(); // then send '1' on DIO (push-pull output)
        else CLEAR_DIO(); // Otherwise send '0' on DIO (push-pull output)

        if (current_bit == 1) // If Last Bit has been written
        {
            delay_us(Delay_Serial);
            SET_CLK(); // Set Clock
            delay_us(Delay_Serial);
            DIO_HIGH_IMP(); // And DIO output of CPU in input mode
            delay_us(Delay_Serial);
            CLEAR_CLK(); // Clear Clock (datasheet timings)
        }
        else // Else generate a CLK pulse to shift the data on DIO
        {
            delay_us(Delay_Serial);
            SET_CLK();
            delay_us(Delay_Serial);
            CLEAR_CLK();
        }
    }
}

```

Table of contents

1	General Description.....	1
2	The AS5030 Adapterboard.....	1
2.1	Board description.....	1
2.2	Mounting the AS5030 adapter board.....	2
3	AS5030 and adapter board pinout.....	3
4	Operation use cases.....	4
4.1	Standalone Analog output mode.....	4
4.2	Standalone PWM output mode.....	4
5	Using the serial interface with MCU.....	5
5.1	2-wire serial interface.....	5
5.2	3-wire serial interface.....	5
5.3	4-wire serial interface.....	6
5.4	Serial daisy chain mode.....	6
6	AS5030 adapterboard hardware.....	7
6.1	AS5030-AB-2.0 schematics.....	7
6.2	AS5030-AB-2.0 PCB layout.....	7
7	C-Source code, simple AGC & Angle read.....	8
	Table of contents.....	9
	Copyrights.....	10
	Disclaimer.....	10
	Contact Information.....	10

Copyrights

Copyright © 1997-2009, austriamicrosystems AG, Schloss Premstaetten, 8141 Unterpremstaetten, Austria-Europe. Trademarks Registered ®. All rights reserved. The material herein may not be reproduced, adapted, merged, translated, stored, or used without the prior written consent of the copyright owner.

All products and companies mentioned are trademarks or registered trademarks of their respective companies.

Disclaimer

Devices sold by austriamicrosystems AG are covered by the warranty and patent indemnification provisions appearing in its Term of Sale. austriamicrosystems AG makes no warranty, express, statutory, implied, or by description regarding the information set forth herein or regarding the freedom of the described devices from patent infringement. austriamicrosystems AG reserves the right to change specifications and prices at any time and without notice. Therefore, prior to designing this product into a system, it is necessary to check with austriamicrosystems AG for current information. This product is intended for use in normal commercial applications. Applications requiring extended temperature range, unusual environmental requirements, or high reliability applications, such as military, medical life-support or lifesustaining equipment are specifically not recommended without additional processing by austriamicrosystems AG for each application.

The information furnished here by austriamicrosystems AG is believed to be correct and accurate. However, austriamicrosystems AG shall not be liable to recipient or any third party for any damages, including but not limited to personal injury, property damage, loss of profits, loss of use, interruption of business or indirect, special, incidental or consequential damages, of any kind, in connection with or arising out of the furnishing, performance or use of the technical data herein. No obligation or liability to recipient or any third party shall arise or flow out of austriamicrosystems AG rendering of technical or other services.

Contact Information

Headquarters

austriamicrosystems AG

A-8141 Schloss Premstaetten, Austria

Tel: +43 (0) 3136 500 0

Fax: +43 (0) 3136 525 01

For Sales Offices, Distributors and Representatives, please visit:

<http://www.austriamicrosystems.com>

X-ON Electronics

Largest Supplier of Electrical and Electronic Components

Click to view similar products for [Magnetic Sensor Development Tools](#) category:

Click to view products by [ams](#) manufacturer:

Other Similar products are found below :

[AS5045 DB V2](#) [AS5134 AB](#) [MMC5633NJL-B](#) [ROTATEKNOBANGLE2GOTOBO1](#) [MIKROE-1647](#) [MIKROE-1646](#) [EVAL-CN0332-PMDZ](#) [AS5510-SO_EK_AB](#) [AS5510-WL_EK_DB](#) [ADA4571R-EBZ](#) [AS5170A-SO_EK_AB](#) [4366](#) [AS5013-QF_EK_AB](#) [AS5040 AB](#) [AS5040 DB V2](#) [AS5040-SS_EK_PB](#) [AS5045 AB](#) [AS5047D-TS_EK_AB](#) [AS5048A-EK-AB-STM1.1](#) [AS5048A-TS_EK_AB](#) [AS5048-TS_EK_DB](#) [AS5050A-QF_EK_AB](#) [AS5132 AB](#) [AS5132 DB](#) [AS5132-PB](#) [AS5140 DB](#) [AS5145B-EK-AB-STM1.0](#) [AS5147P-TS_EK_AB](#) [AS5162-EK-AB](#) [AS5172B-TS_EK_AB](#) [AS5247-MF_EK_SB](#) [AS5247U-TQ_EK_AB](#) [AS5247U-TQ_EK_SB](#) [AS5262-MF_EK_AB](#) [AS5311-TS_EK_AB](#) [AS5510-SOIC8-AB](#) [AS5600-SO_EK_AB](#) [AS5600-SO_EK_ST](#) [AS5601-SO_EK_AB](#) [AS5601-SO_EK_ST](#) [AS5601-SO_RD_ST](#) [AS5X47U-TS_EK_AB](#) [SD4Y-EK-XX](#) [USB I&P BOX](#) [EVAL-CN0323-SDPZ](#) [EVAL-CN0368-SDPZ](#) [DFR0033](#) [OUTOFSHAFTFOR3D2GOTOBO1](#) [S2GO3DSENSETLV493DTOBO1](#) [S2GOCURSENSETLI4970TOBO1](#)