



austriamicrosystems AG

is now

ams AG

The technical content of this austriamicrosystems document is still valid.

Contact information:

Headquarters:

ams AG

Tobelbaderstrasse 30

8141 Unterpremstaetten, Austria

Tel: +43 (0) 3136 500 0

e-Mail: ams_sales@ams.com

Please visit our website at www.ams.com

AS5040/AS5045/AS5140/AS5145/AS5145-I10(-I12)

AS5040-AB-v2.0
Adapterboard

Programmable Magnetic Rotary Encoder

OPERATION MANUAL

1 General Description

The AS5x40/AS5x45 series are contactless magnetic rotary encoders for accurate angular measurement over a full turn of 360°. They are system-on-chip, combining integrated Hall elements, analog front end and digital signal processing in a single device.

To measure the angle, only a simple two-pole magnet, rotating over the center of the chip, is required. The magnet may be placed above or below the IC.

The absolute angle measurement provides instant indication of the magnet's angular position with a resolution of $0.35^\circ = 1024$ (AS5x40 – 10bit) or $0.0879^\circ = 4096$ (AS5x45 – 12bit) positions per revolution. This digital data is available as a serial bit stream and as a PWM signal.

Furthermore, a user-programmable incremental output is available, making the chip suitable for replacement of various optical encoders.

The AS5145 is also available as 10bit or 12bit pre-programmed version AS5145-I10(-I12).

An internal voltage regulator allows the AS5x40/AS5x45 to operate at either 3.3 V or 5 V supplies.

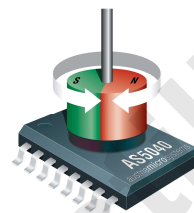

2 The AS5040 Adapter board

2.1 Board description

The AS5040 adapter board is a simple circuit allowing test and evaluation of the AS5040/AS5045/AS5140/AS5145/AS5145-I10/AS5145-I12 rotary encoder quickly without building a test fixture or PCB.

The PCB can be used as standalone unit or attached to a microcontroller. The standalone operation requires a 5V power supply only; the magnet's angle can be read on the PWM or analog output.

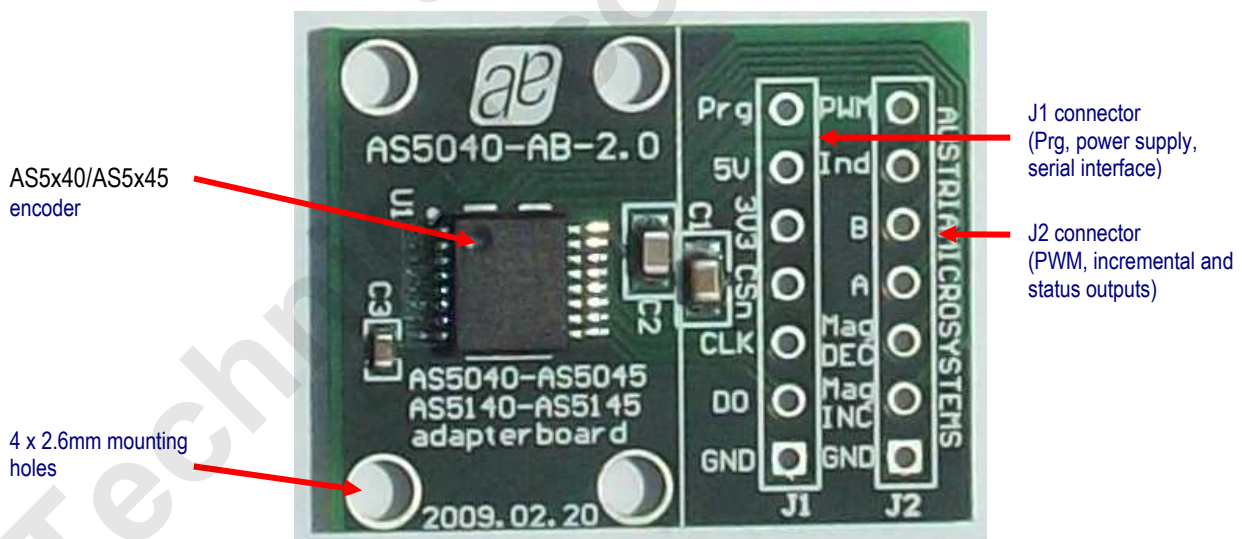

Figure 1: AS5040 Adapterboard

2.2 Mounting the AS5040 adapter board

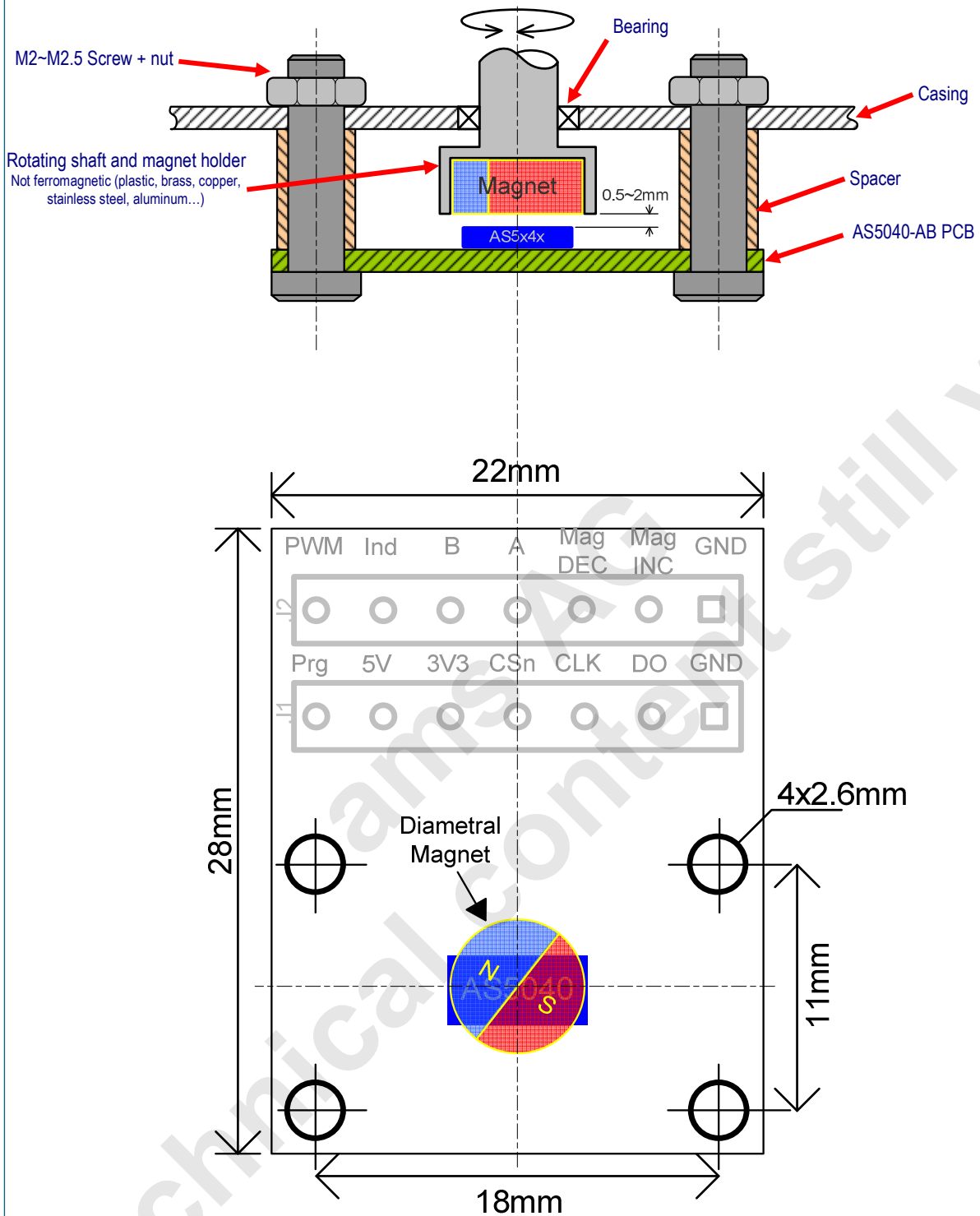

Figure 2: AS5040 adapter board mounting and dimension

A diametric magnet must be placed over on under the AS5x40/AS5x45 encoder, and should be centered on the middle of the package with a tolerance of 0.5mm.

The airgap between the magnet and the encoder casing should be maintained in the range 0.5mm~2mm.

The magnet holder must not be ferromagnetic. Materials as brass, copper, aluminum, stainless steel are the best choices to make this part.

3 AS5x40/AS5x45 and adapter board pinout

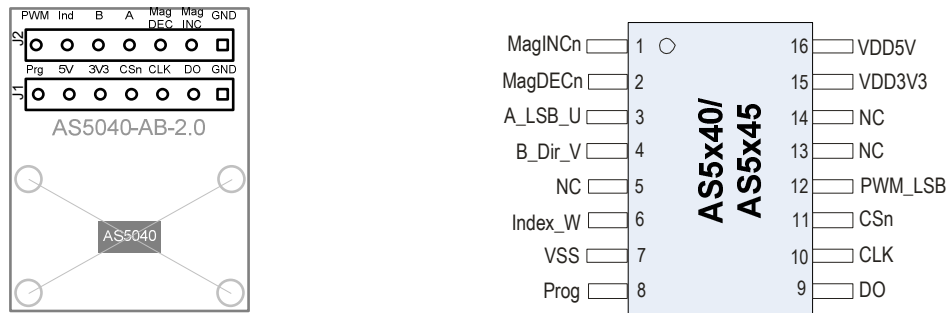

Figure 3: AS5040 adapter board connectors and encoder pinout

Pin# Board	Pin# AS5040	Symbol Board	Type	Description
JP1 - 1	7	GND	S	Supply ground
JP1 - 2	9	DO	DO_T	Data Output of Synchronous Serial Interface
JP1 - 3	10	CLK	DI_ST	Clock Input of Synchronous Serial Interface; Schmitt-Trigger input
JP1 - 4	11	CSn	DI_PU_ST	Chip Select, active low; Schmitt-Trigger input, internal pull-up resistor (~50kΩ) connect to VSS in incremental mode
JP1 - 5	15	3V3	S	3V-Regulator Output
JP1 - 6	16	5V	S	5V Supply
JP1 - 7	8	Prg	DI_PD	OTP Programming Input and Data Input for Daisy Chain mode. Internal pull-down resistor (~74kΩ). May be connected to VSS if programming is not used
JP2 - 1	7	GND	S	Supply ground
JP2 - 2	1	MagINC	DO_OD	Magnet Field Magnitude INCREASE ; active low, indicates a distance reduction between the magnet and the device surface.
JP2 - 3	2	MagDEC	DO_OD	Magnet Field Magnitude DECREASE ; active low, indicates a distance increase between the device and the magnet
JP2 - 4	3	A	DO	AS5040 – AS5140 – AS5145 (programmed) only Mode1.x: Quadrature A channel Mode2.x: Least Significant Bit Mode3.x: U signal (phase1)
JP2 - 5	4	B	DO	AS5040 – AS5140 – AS5145 (programmed) only Mode1.x: Quadrature B channel quarter period shift to channel A. Mode2.x: Direction of Rotation Mode3.x: V signal (phase2)
JP2 - 6	6	Ind	DO	AS5040 – AS5140 – AS5145 (programmed) only Mode1.x and Mode2.x: Index signal indicates the absolute zero position Mode3.x: W signal (phase3) AS5045 – AS5145 (unprogrammed) Mode input, connect to VDD5 (Fast mode) or GND (Slow mode); do not change during operation
JP2 - 7	12	PWM	DO	Pulse Width Modulation of approx. 1kHz; LSB in Mode3.x

Table 1: Pin description

Pin types:	DO_OD	digital output open drain	S	supply pin
	DO	digital output	DI	digital input
	DI_PD	digital input pull-down	DO_T	digital output / tri-state
	DI_PU	digital input pull-up	ST	Schmitt-Trigger input

4 Operation use cases

4.1 Standalone SSI output mode

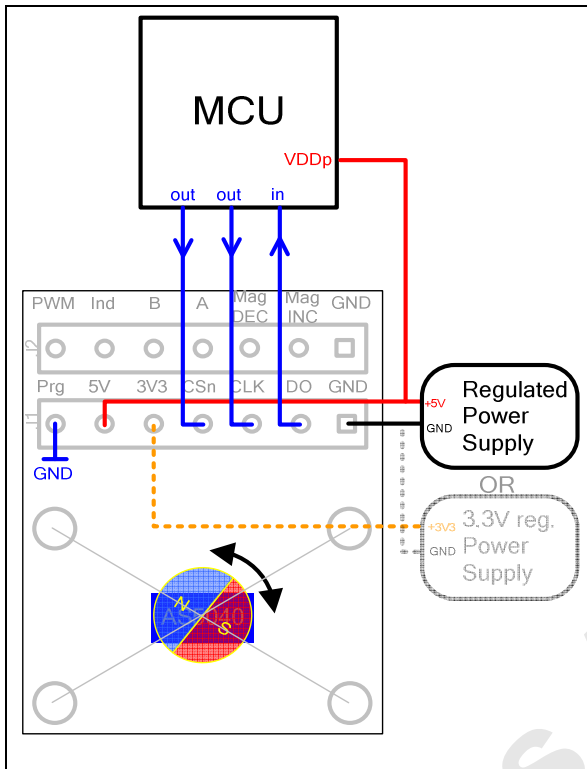

Figure 4: Using the analog output with the adapter board

The most complete and accurate solution for a MCU to read the angle of a magnet is the serial interface. The serial word contains 16 bits for AS5x40 or 18 bits for AS5x45 and consists of 10 bit (AS5x40) or 12 bit (AS5x45) angle value and some other indicator bits like MagINC, MagDEC, which can be read at the same time.

4.2 Standalone PWM output mode

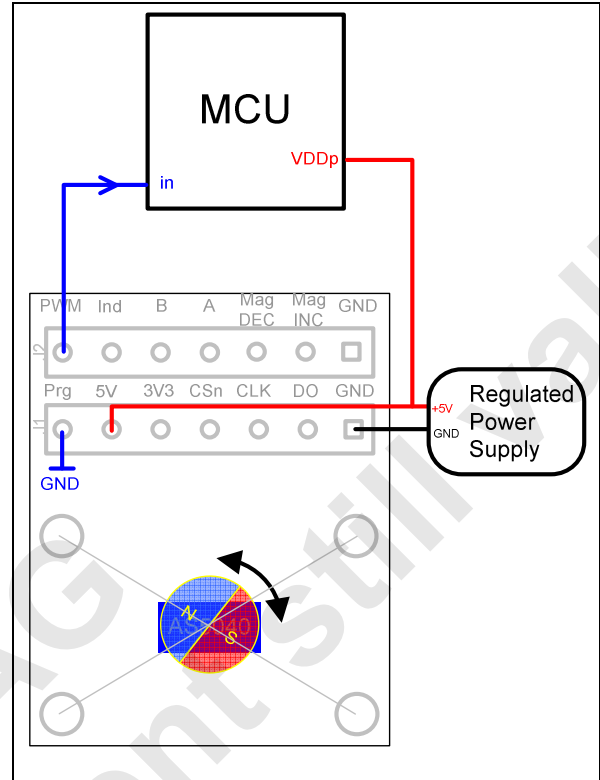

Figure 5: Using the PWM output with the adapter board

The AS5040 provides a pulse width modulated output (PWM), whose duty cycle is proportional to the measured angle. The PWM signal (J2 pin #7) with a period of 1025 μ s (1 μ s step) and 5V pulse voltage can be connected to the capture/timer input of a microcontroller in order to decode the angle value.

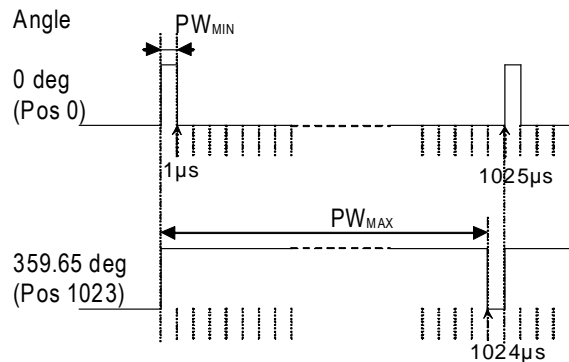

Figure 6: PWM duty cycle depending on magnet position

4.3 Standalone incremental output

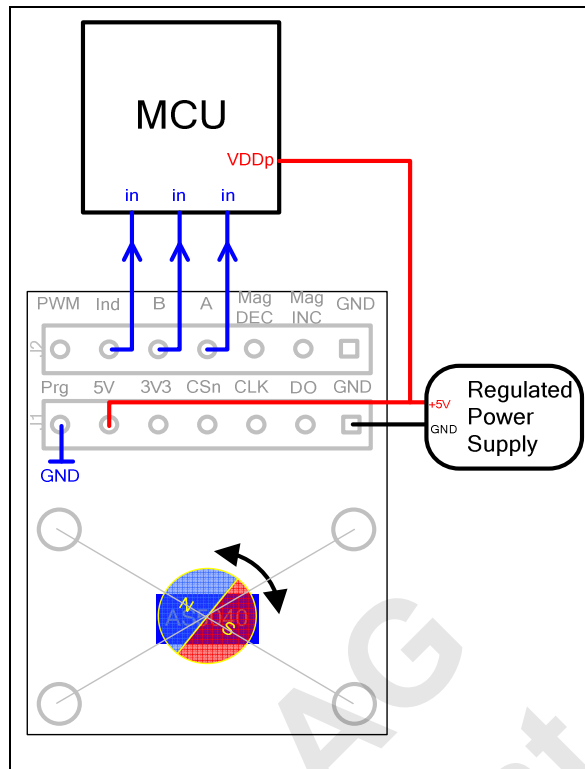

Figure 7: Using the Incremental output with the adapter board

Three different incremental output modes are possible with quadrature A/B being the default mode (two-channel quadrature, step / direction incremental signal (LSB) and the direction bit in clockwise (CW) and counter-clockwise (CCW) direction. The pre-programmed version AS5145-I10 provides a 10bit and AS5145-I12 a 12bit incremental output.

The AS5045 do not offer an incremental output (see chapter 6).

For further information, please refer to datasheet.

4.4 Daisy chain mode

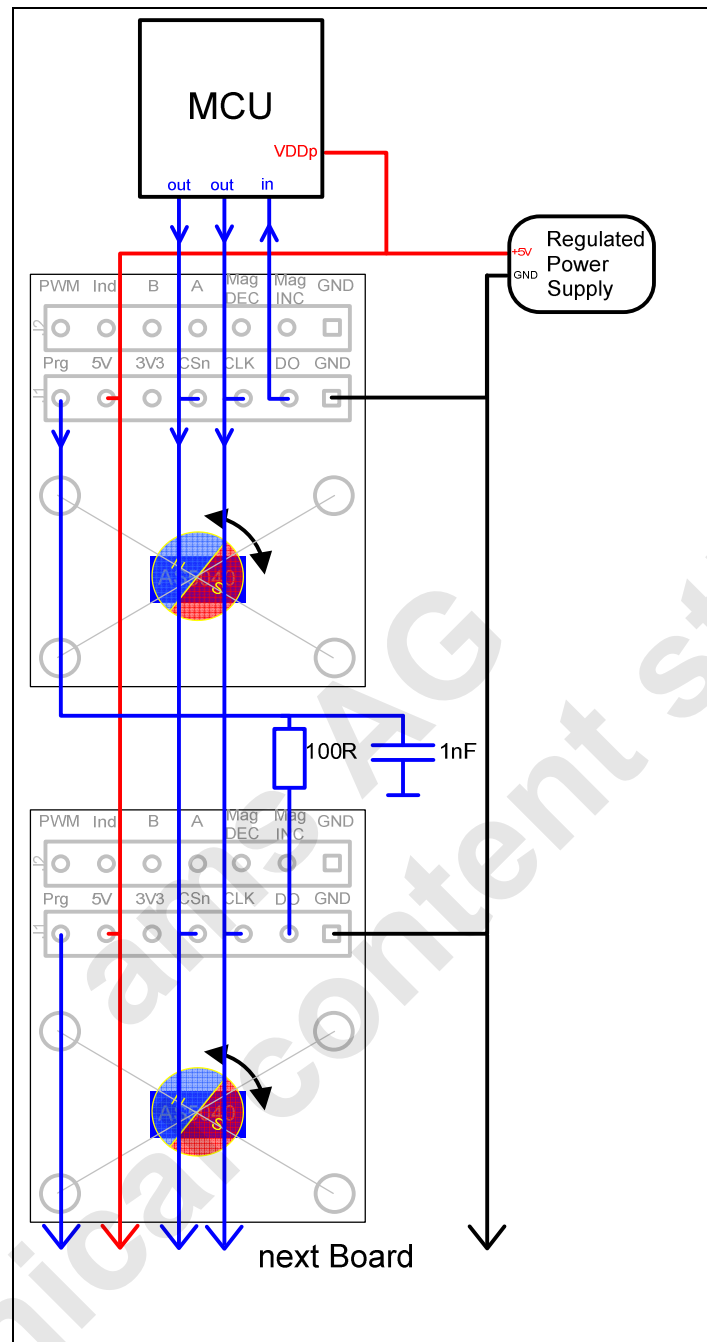

Figure 8: Using Daisy-Chain mode with the adapter board

By using more than one adapter board, a setup in daisy chain mode is possible.

In this mode capacitor C3 (refer to Fig.10) must be disconnected when using the 1nF capacitor shown in Fig.8. or directly replaced by this capacitor.

The serial data of all connected devices is read from the DO pin of the first device in the chain. The Prog pin of the last device in the chain should be connected to VSS. The length of the serial bit stream increases with every connected device (board) by $n * (16+1)$ bits.

Due to $R = 100\Omega$ and $C = 1\text{nF}$, the CLK is limited the maximum 1MHz.

5 Programming the AS5040

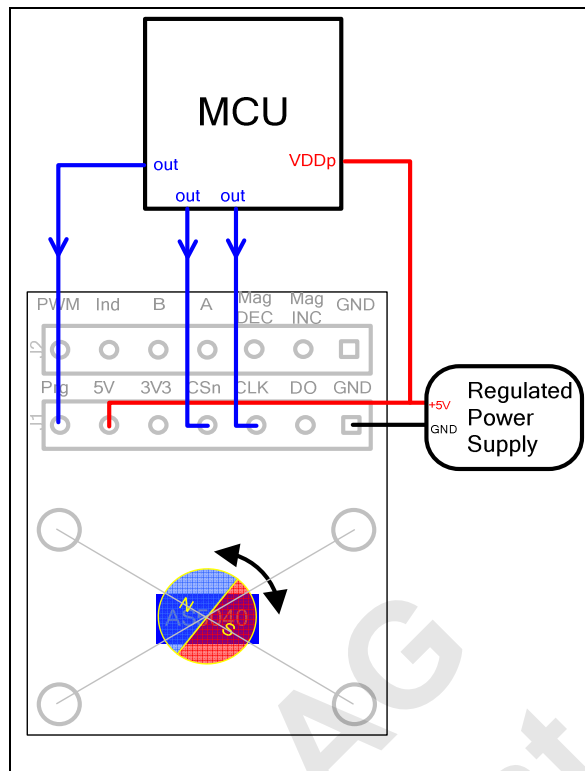

Figure 9: Programming the AS5040

After power-on, programming the AS5040 is enabled with the rising edge of CSn with Prog = high and CLK = low. 16 bit configuration data must be serially shifted into the OTP register via the Prog-pin. The first "CCW" bit is followed by the zero position data (MSB first / 10 bit for AS5x40 and 12 bit for AS5x45) and some mode settings (please refer to datasheet). Data must be valid at the rising edge of CLK.

After writing data into the OTP register it can be permanently programmed by rising the Prog pin to the programming voltage V_{PROG} of 7.3-7.5V. 16 CLK pulses must be applied to program the fuses.

For exiting the programming mode, the chip must be reset by a power-on-reset. The programmed data is available after the next power-up.

6 AS5040 Differences to AS5045

Building Block	AS5045	AS5040
Resolution	12bits, 0.088°/step.	10bit, 0.35°/step
Data length	read: 18bits (12bits data + 6 bits status) OTP write: 18 bits (12bits zero position + 6 bits mode selection)	read: 16bits (10bits data + 6 bits status) OTP write: 16 bits (10bits zero position + 6 bits mode selection)
incremental encoder	Not used Pin 3: not used Pin 4: not used	quadrature, step/direction and BLDC motor commutation modes Pin 3: incremental output A_LSB_U Pin 4: incremental output B_DIR_V
Pins 1 and 2	MagINCn, MagDECn: same feature as AS5040, additional OTP option for red-yellow-green magnetic range	MagINCn, MagDECn indicate in-range or out-of-range magnetic field plus movement of magnet in z-axis
Pin 6	MODE pin, switch between fast and slow mode	Pin 6: Index output
Pin 12	PWM output: frequency selectable by OTP: 1µs / step, 4096 steps per revolution, f=244Hz 2µs / step, 4096 steps per revolution, f=122Hz	PWM output: 1µs / step, 1024 steps per revolution, 976Hz PWM frequency
sampling frequency	selectable by MODE input pin: 2.5kHz, 10kHz	fixed at 10kHz @10bit resolution
Propagation delay	384µs (slow mode) 96µs (fast mode)	48µs
Transition noise (rms; 1sigma)	0.03 degrees max. (slow mode) 0.06 degrees max. (fast mode)	0.12 degrees
OTP programming options	zero position, rotational direction, PWM disable, 2 Magnetic Field indicator modes, 2 PWM frequencies	zero position, rotational direction, incremental modes, index bit width

7 AS5040 adapter board hardware

7.1 AS5040-AB-2.0 schematics

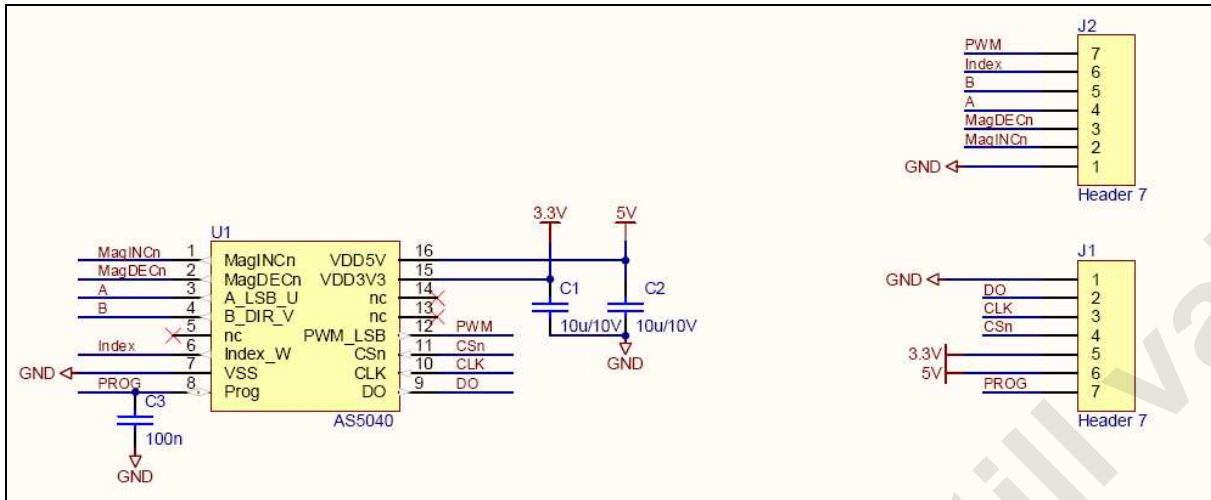

Figure 10: AS5040-AB-2.0 adapterboard schematics

7.2 AS5040-AB-2.0 PCB layout

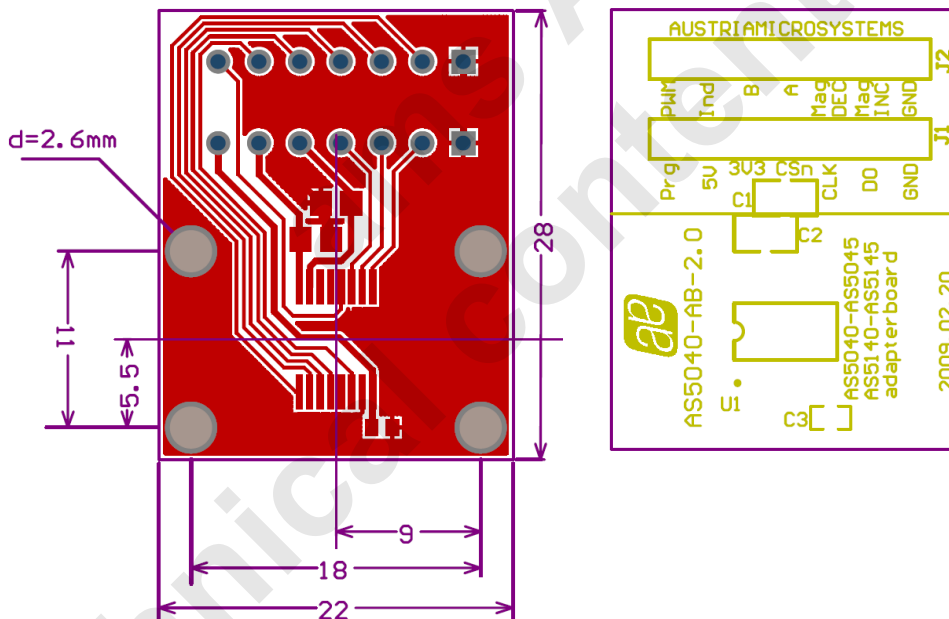

Figure 11: AS5040-AB-2.0 adapter board layout

Table of contents

1	General Description	1
2	The AS5040 Adapter board	1
2.1	Board description	1
2.2	Mounting the AS5040 adapter board	2
3	AS5x40/AS5x45 and adapter board pinout	3
4	Operation use cases	4
4.1	Standalone SSI output mode	4
4.2	Standalone PWM output mode	4
4.3	Standalone incremental output	5
	Figure 7: Using the Incremental output with the adapter board	5
4.4	Daisy chain mode	6
5	Programming the AS5040	7
6	AS5040 Differences to AS5045	8
7	AS5040 adapter board hardware	9
7.1	AS5040-AB-2.0 schematics	9
7.2	AS5040-AB-2.0 PCB layout	9
	Table of contents	10
	Copyrights	11
	Disclaimer	11
	Contact Information	11

Copyrights

Copyright © 1997-2009, austriamicrosystems AG, Schloss Premstaetten, 8141 Unterpremstaetten, Austria-Europe. Trademarks Registered ®. All rights reserved. The material herein may not be reproduced, adapted, merged, translated, stored, or used without the prior written consent of the copyright owner. All products and companies mentioned are trademarks or registered trademarks of their respective companies.

Disclaimer

Devices sold by austriamicrosystems AG are covered by the warranty and patent indemnification provisions appearing in its Term of Sale. austriamicrosystems AG makes no warranty, express, statutory, implied, or by description regarding the information set forth herein or regarding the freedom of the described devices from patent infringement. austriamicrosystems AG reserves the right to change specifications and prices at any time and without notice. Therefore, prior to designing this product into a system, it is necessary to check with austriamicrosystems AG for current information. This product is intended for use in normal commercial applications. Applications requiring extended temperature range, unusual environmental requirements, or high reliability applications, such as military, medical life-support or lifesustaining equipment are specifically not recommended without additional processing by austriamicrosystems AG for each application. The information furnished here by austriamicrosystems AG is believed to be correct and accurate. However, austriamicrosystems AG shall not be liable to recipient or any third party for any damages, including but not limited to personal injury, property damage, loss of profits, loss of use, interruption of business or indirect, special, incidental or consequential damages, of any kind, in connection with or arising out of the furnishing, performance or use of the technical data herein. No obligation or liability to recipient or any third party shall arise or flow out of austriamicrosystems AG rendering of technical or other services.

Contact Information

Headquarters

austriamicrosystems AG
A-8141 Schloss Premstaetten, Austria
Tel: +43 (0) 3136 500 0
Fax: +43 (0) 3136 525 01

For Sales Offices, Distributors and Representatives, please visit:
<http://www.austriamicrosystems.com>

X-ON Electronics

Largest Supplier of Electrical and Electronic Components

Click to view similar products for [Magnetic Sensor Development Tools](#) category:

Click to view products by [ams](#) manufacturer:

Other Similar products are found below :

[AS5045 DB V2](#) [AS5134 AB](#) [MMC5633NJL-B](#) [ROTATEKNOBANGLE2GOTOBO1](#) [MIKROE-1647](#) [MIKROE-1646](#) [EVAL-CN0332-PMDZ](#) [AS5510-SO_EK_AB](#) [AS5510-WL_EK_DB](#) [ADA4571R-EBZ](#) [AS5170A-SO_EK_AB](#) [4366](#) [AS5013-QF_EK_AB](#) [AS5040 AB](#) [AS5040 DB V2](#) [AS5040-SS_EK_PB](#) [AS5045 AB](#) [AS5047D-TS_EK_AB](#) [AS5048A-EK-AB-STM1.1](#) [AS5048A-TS_EK_AB](#) [AS5048-TS_EK_DB](#) [AS5050A-QF_EK_AB](#) [AS5132 AB](#) [AS5132 DB](#) [AS5132-PB](#) [AS5140 DB](#) [AS5145B-EK-AB-STM1.0](#) [AS5147P-TS_EK_AB](#) [AS5162-EK-AB](#) [AS5172B-TS_EK_AB](#) [AS5247-MF_EK_SB](#) [AS5247U-TQ_EK_AB](#) [AS5247U-TQ_EK_SB](#) [AS5262-MF_EK_AB](#) [AS5311-TS_EK_AB](#) [AS5510-SOIC8-AB](#) [AS5600-SO_EK_AB](#) [AS5600-SO_EK_ST](#) [AS5601-SO_EK_AB](#) [AS5601-SO_EK_ST](#) [AS5601-SO_RD_ST](#) [AS5X47U-TS_EK_AB](#) [SD4Y-EK-XX](#) [USB I&P BOX](#) [EVAL-CN0323-SDPZ](#) [EVAL-CN0368-SDPZ](#) [DFR0033](#) [OUTOFSHAFTFOR3D2GOTOBO1](#) [S2GO3DSENSETLV493DTOBO1](#) [S2GOCURSENSETLI4970TOBO1](#)