

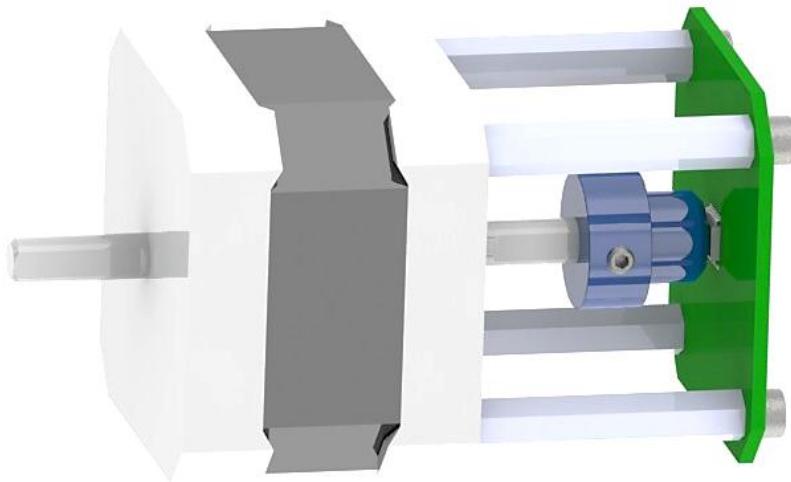

Operation Manual: AS5145B-EK-AB-STM1.0



AS5145B Eval-Kit Stepper Motor



Table of Contents

- 1. General Description 2
- 2. Package and Board Description 2
- 3. How to get the Eval-Kit running 4
- 4. Mechanical Design Considerations 5
- 5. Schematics, Layout 6
- Copyright** 9
- Disclaimer** 9
- Contact Information** 9

1. General Description

The AS5145B Eval-Kit is designed to adapt standard size stepper motors with a contactless rotary position sensor. Rotation of the magnet holders is sensed by the rotary position sensor, soldered on the PCB board.

2. Package and Board Description

Content of the Eval-Kit:

- AS5145B board

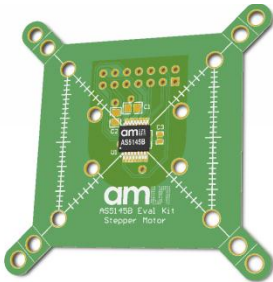

- 4 magnet holders



Ø 5mm

Ø 6mm

Ø 8mm

Ø 10mm

- 1 allen key (1.5mm)



- 1 quick start user guide

Figure 1: Connector

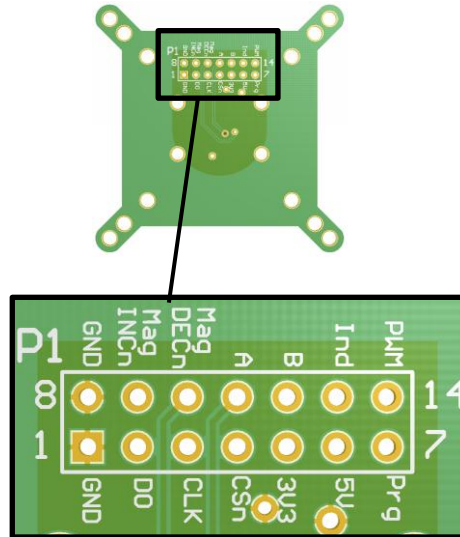
Table 1:
Connector pinout

Pin	Description	Info
1	GND	Ground
2	DO	Data Output of SSI
3	CLK	Clock Input of SSI
4	CSn	Chip Select
5	3V3	3.3V-Regulator Output.
6	5V	Positive Supply Voltage.
7	Prg	Programming Input.
8	GND	GND
9	MagINCn	magnet field status indicator
10	MagDECn	magnet field status indicator
11	A	Quadrature Output A
12	B	Quadrature Output B
13	Ind	Index Output
14	PWM	Pulse Width Modulation output

3. How to get the Eval-Kit running

Figure 2:
5V Power Option

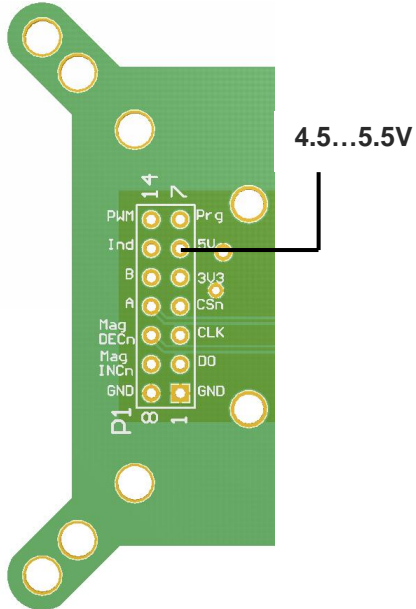
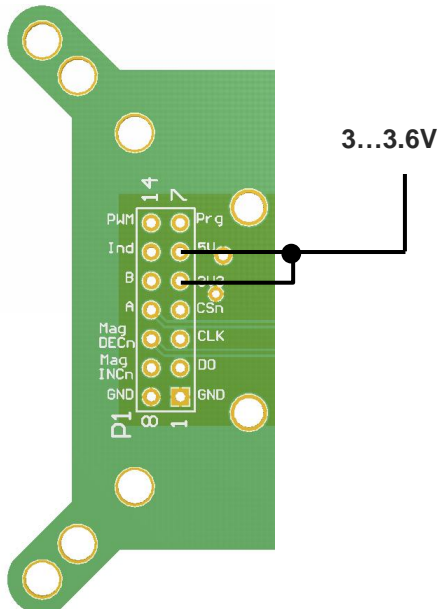

Figure 3:
3V Power Option



4. Mechanical Design Considerations

Table 2:
Motor References (Examples)

Part Number	Web Page	Manufacturer
17PY-X0XX	www.nmbtc.com	NMB Technologies Corporation - Motor Group
17PY-X8XX		
17PY-X4XX		
17H018D series	www.portescap.com	Portescap
17H118D series		
17H218D series		



Table 3:
Used Magnet

Part Number	Web Page	Manufacturer
2910041-1	www.dexterimg.com	Dexter Magnetic Technologies



Additional recommended magnet suppliers refer to our homepage:

<http://www.ams.com/eng/Products/Magnetic-Encoders/Magnets2/Recommended-Magnet-Suppliers>

Figure 4:
Mounting the AS5145B Eval-Kit

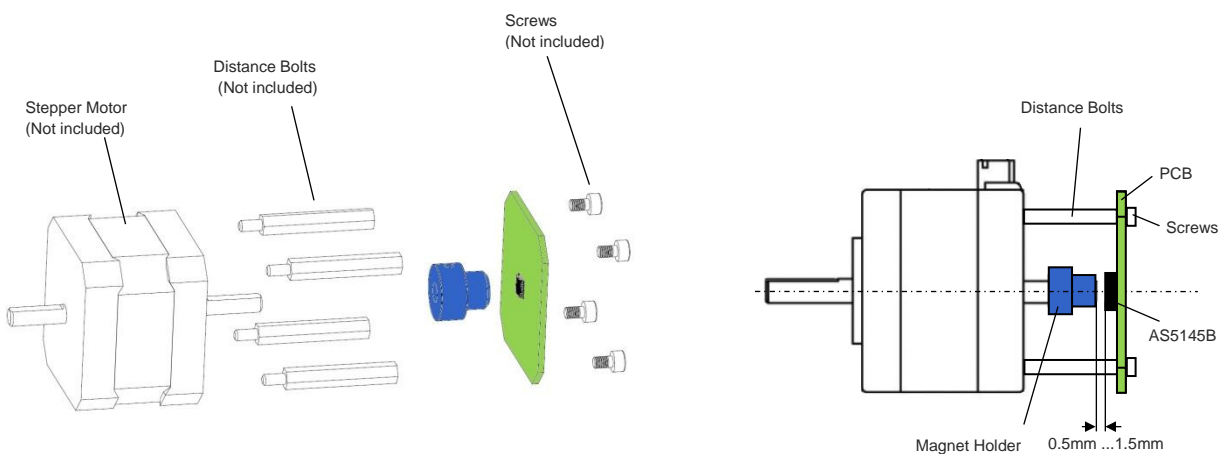

The AS5145B board can be mounted on double shaft motors. (See figure 4)

Screws and distance bolts are not included.

5. Schematics, Layout

Figure 5:
Schematic

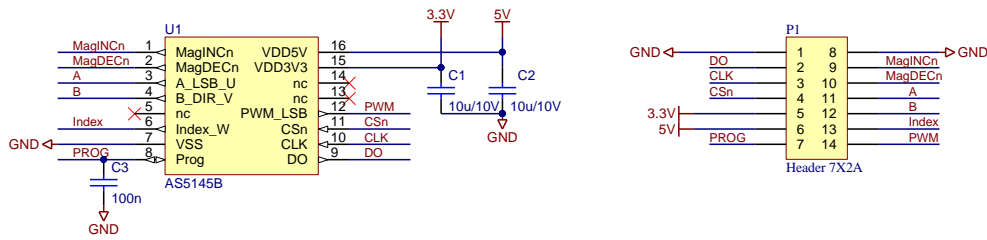

Figure 6:
Top Layer

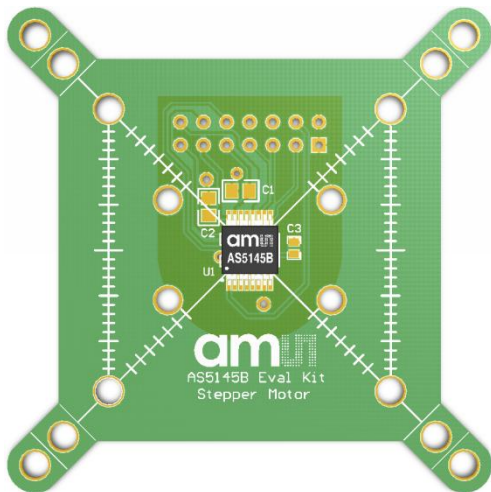

Figure 7:
Bottom Layer

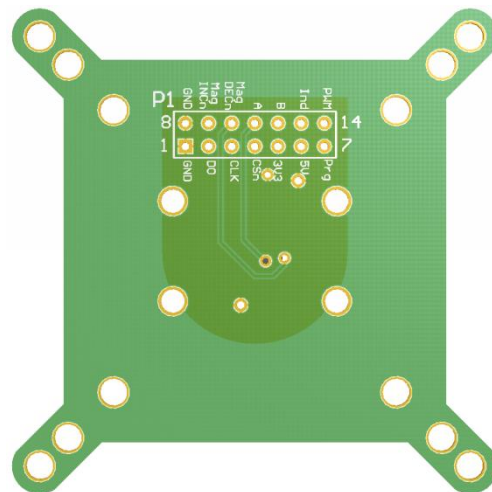

Table 4:
Bill of Materials

Pos	Part Number	Reference
1	PCB Board	PCB1
2	U1	AS5145B
3	C1	10uF/10V/0805
4	C2	10uF/10V/0805
5	C3	100nF/10V/0603
6	P1	14 Pin Header

Figure 8:
Magnet Holder



Grub screw for fixing on the shaft of the motor.

Figure 9:
Magnet Holder Dimensions

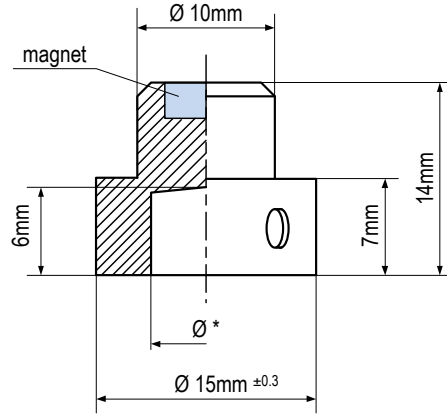

- *Ø 5mm
- *Ø 6mm
- *Ø 8mm
- *Ø 10mm

Figure 10:
Layout Dimensions

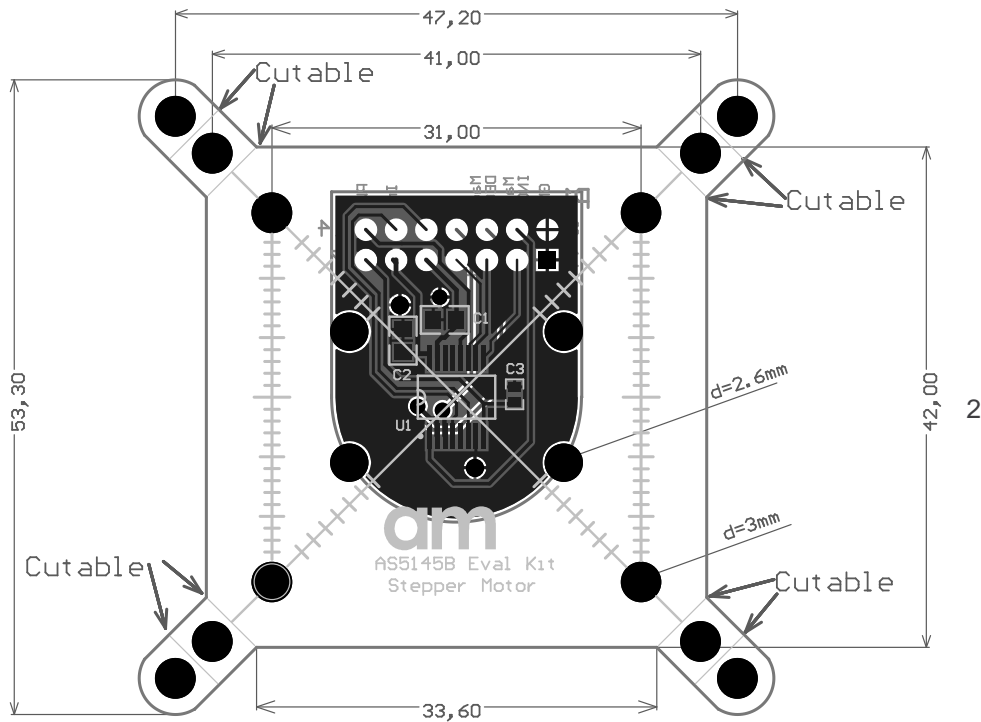

6. Ordering Information

Table 5:
Ordering Information

Ordering Code	Description
AS5145B-EK-AB-STM1.0	AS5145B Eval-Kit Stepper Motor with ABI, SSI, PWM

Revisions History

Revision	Date	Description
1.0	August 6, 2012	First version
1.1	Januar 23, 2014	Updated to new board design

Copyright

Copyright ams AG, Tobelbader Strasse 30, 8141 Unterpremstätten, Austria-Europe. Trademarks Registered. All rights reserved. The material herein may not be reproduced, adapted, merged, translated, stored, or used without the prior written consent of the copyright owner.

Disclaimer

Devices sold by ams AG are covered by the warranty and patent indemnification provisions appearing in its Term of Sale. ams AG makes no warranty, express, statutory, implied, or by description regarding the information set forth herein. ams AG reserves the right to change specifications and prices at any time and without notice. Therefore, prior to designing this product into a system, it is necessary to check with ams AG for current information. This product is intended for use in commercial applications. Applications requiring extended temperature range, unusual environmental requirements, or high reliability applications, such as military, medical life-support or life-sustaining equipment are specifically not recommended without additional processing by ams AG for each application. This Product is provided by ams "AS IS" and any express or implied warranties, including, but not limited to the implied warranties of merchantability and fitness for a particular purpose are disclaimed.

ams AG shall not be liable to recipient or any third party for any damages, including but not limited to personal injury, property damage, loss of profits, loss of use, interruption of business or indirect, special, incidental or consequential damages, of any kind, in connection with or arising out of the furnishing, performance or use of the technical data herein. No obligation or liability to recipient or any third party shall arise or flow out of ams AG rendering of technical or other services.

Contact Information

Headquarters

ams AG

Tobelbader Strasse 30
8141 Unterpremstaetten

Austria

T. +43 (0) 3136 500 0

For Sales Offices, Distributors and Representatives, please visit:

<http://www.ams.com/contact>

X-ON Electronics

Largest Supplier of Electrical and Electronic Components

Click to view similar products for [Magnetic Sensor Development Tools](#) category:

Click to view products by [ams](#) manufacturer:

Other Similar products are found below :

[AS5045 DB V2](#) [AS5134 AB](#) [MMC5633NJL-B](#) [ROTATEKNOBANGLE2GOTOBO1](#) [MIKROE-1647](#) [MIKROE-1646](#) [EVAL-CN0332-PMDZ](#) [AS5510-SO_EK_AB](#) [AS5510-WL_EK_DB](#) [ADA4571R-EBZ](#) [AS5170A-SO_EK_AB](#) [4366](#) [AS5013-QF_EK_AB](#) [AS5040 AB](#) [AS5040 DB V2](#) [AS5040-SS_EK_PB](#) [AS5045 AB](#) [AS5047D-TS_EK_AB](#) [AS5048A-EK-AB-STM1.1](#) [AS5048-TS_EK_DB](#) [AS5050A-QF_EK_AB](#) [AS5132 AB](#) [AS5132 DB](#) [AS5132-PB](#) [AS5140 DB](#) [AS5145B-EK-AB-STM1.0](#) [AS5147P-TS_EK_AB](#) [AS5162-EK-AB](#) [AS5172B-TS_EK_AB](#) [AS5247-MF_EK_SB](#) [AS5247U-TQ_EK_AB](#) [AS5247U-TQ_EK_SB](#) [AS5262-MF_EK_AB](#) [AS5311-TS_EK_AB](#) [AS5510-SOIC8-AB](#) [AS5600-SO_EK_AB](#) [AS5600-SO_EK_ST](#) [AS5601-SO_EK_AB](#) [AS5601-SO_EK_ST](#) [AS5601-SO_RD_ST](#) [AS5X47U-TS_EK_AB](#) [SD4Y-EK-XX](#) [USB I&P BOX](#) [EVAL-CN0323-SDPZ](#) [EVAL-CN0368-SDPZ](#) [DFR0033](#) [OUTOFSHAFTFOR3D2GOTOBO1](#) [S2GO3DSENSETLV493DTOBO1](#) [S2GOCURSENSETLI4970TOBO1](#) [TLE5012BE5000MS2GOTOBO1](#)