



User Manual – AS5304 / AS5306 Demo Kit

**AS5304 / AS5306**

**160-step Linear Incremental Position  
Sensor with ABI output**

## Table of Contents

1. General Description .....	2
2. Package and Board Description .....	3
3. How to get the kit running .....	7
4. Design Considerations .....	8
5. Schematics and BOM .....	9
6. Ordering Information.....	11
Copyright.....	12
Disclaimer .....	12

## 1. General Description

This document describes the features and operation of the AS5304/-06 Demo Kit.

The AS5304 and AS5306 are Hall-based linear incremental magnetic position sensors. They are suitable for high resolution, contactless linear or off-axis rotary position sensing utilizing multipole strip or ring magnets.

The AS5304 Demo-kit mounts a multi-pole strip magnet with 2mm pole length and has a resolution of 25µm per step, while the AS5306 uses a multi-pole strip magnet with 1.2mm pole length and has a resolution of 15µm per step. Both AS5304 and AS5306 have 160-step measurement range.

These demo kits allow the user to evaluate the AS5304/AS5306 in stand-alone mode. This can be accomplished using connectors on the backside of the board.

For linear motion sensing, a multi-pole strip magnet is required (Figure 1). For off-axis rotary motion sensing a multi-pole ring magnet is used (Figure 2).

Figure 1:  
Arrangement with multi-pole strip magnet

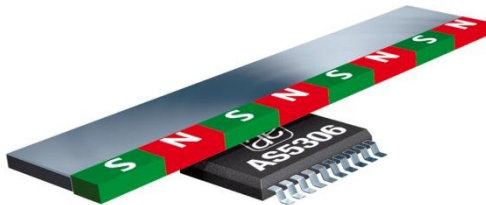

Figure 2:  
Arrangement with multi-pole ring magnet



## 2. Package and Board Description

### Demo Kit Contents

The demo kit includes following items listed below in Table 1.

Table 1:  
Demo Kit Contents

Pos	Item	Comment
1	AS5304/AS5306 demo board	Including mechanics
2	USB 2.0 cable	For demo board supply
3	Multipole Magnet Slider	
4	Quick Start Guide	

### Board Description

Figure 3:  
Demo board

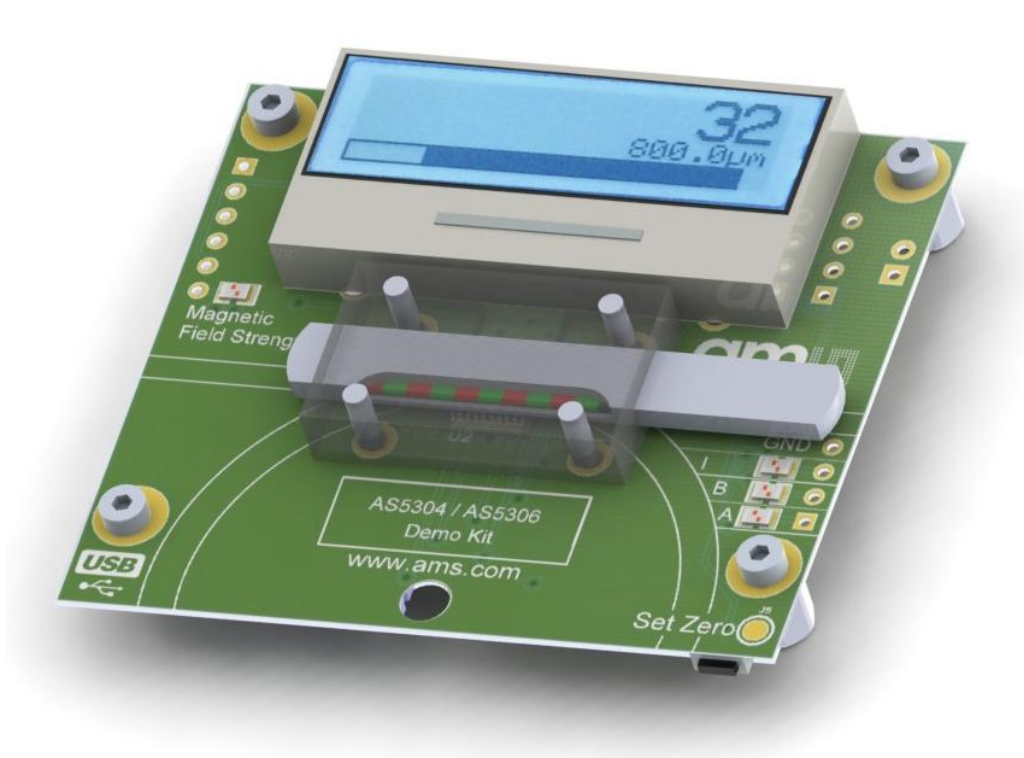
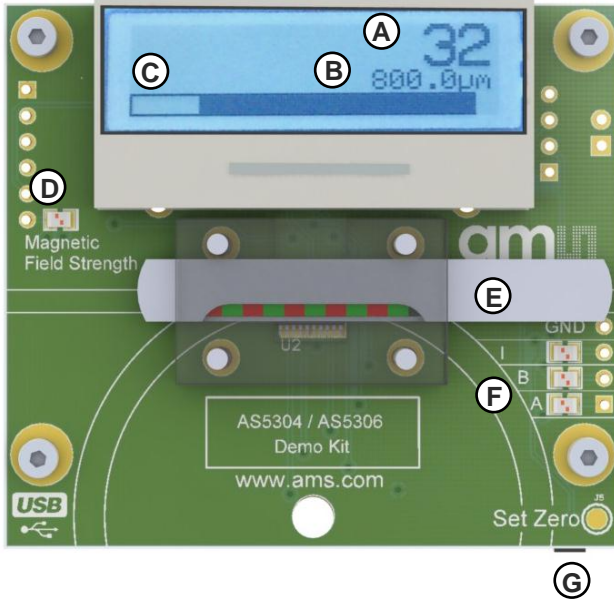

Figure 4:  
Demo board front view



- (A) Incremental steps
- (B) Calculated position
- (C) Pole Pair Indicator
- (D) Magnetic Field Strength Indicator LED
- (E) Multipole Magnet Slider
- (F) ABI indicator LED's
- (G) Zero position reset button

**Additional Information about the Position Sensor**

On the back side, there are several options to connect directly to the signals of the demo board for further evaluation of the chip.

Figure 5:  
Demo board back view

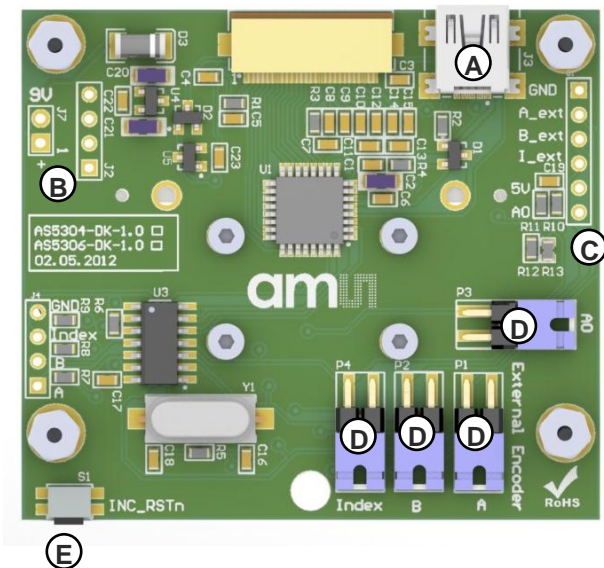

- (A) USB connector
- (B) Battery connector
- (C) Position sensor connector  
(see Table 2 and Figure 6 for details)
- (D) Jumper to disconnect onboard position sensor  
(see Figure 7 for details)
- (E) Zero position reset button

## Position Sensor Connector

The Position connector allows the user to monitor the ABI signals from the AS5304/AS5306 as well as to connect this demoboard to an external sensor (see below, Connection of an external Sensor) as shown in Figure 7.

Table 2:  
Position sensor connector pin out

Pin	Pin Name	Description
1	GND	Ground Signal
2	A_ext	A output
3	B_ext	B output
4	I_ext	I output
5	5V	Position Sensor supply
6	AO	Analog Output

Figure 6:  
Position sensor connector

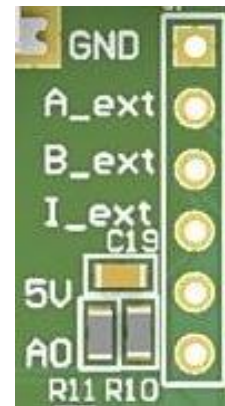

If the on-board sensor is used for the measurements the Analog Output (AO) provides an analog output voltage that represents the Automatic Gain Control of the position sensor signal control loop. This output is used to monitor the magnetic field strength respectively the air gap between sensor and multipole magnet strip. For more details refer to the position sensor datasheet.

## Connection of an external Sensor

With the jumpers, the onboard position sensor can be disconnected to use an external position sensor. Follow the instructions below to use an external position sensor.

- (1) Disconnect the power supply of the demoboard by unplugging the USB cable.
- (2) Disconnect the onboard position sensor by removing P1, P2, P3, and P4 jumpers. See Figure 7.
- (3) As the onboard position sensor is disconnected, connect an external position sensor. For example an AS5304 / AS5306 adapter board can be used. See Figure 7.

The AS5304 / AS5306 AB adapter board is optional and not included in the demo kit.

Figure 7:  
Using an external position sensor

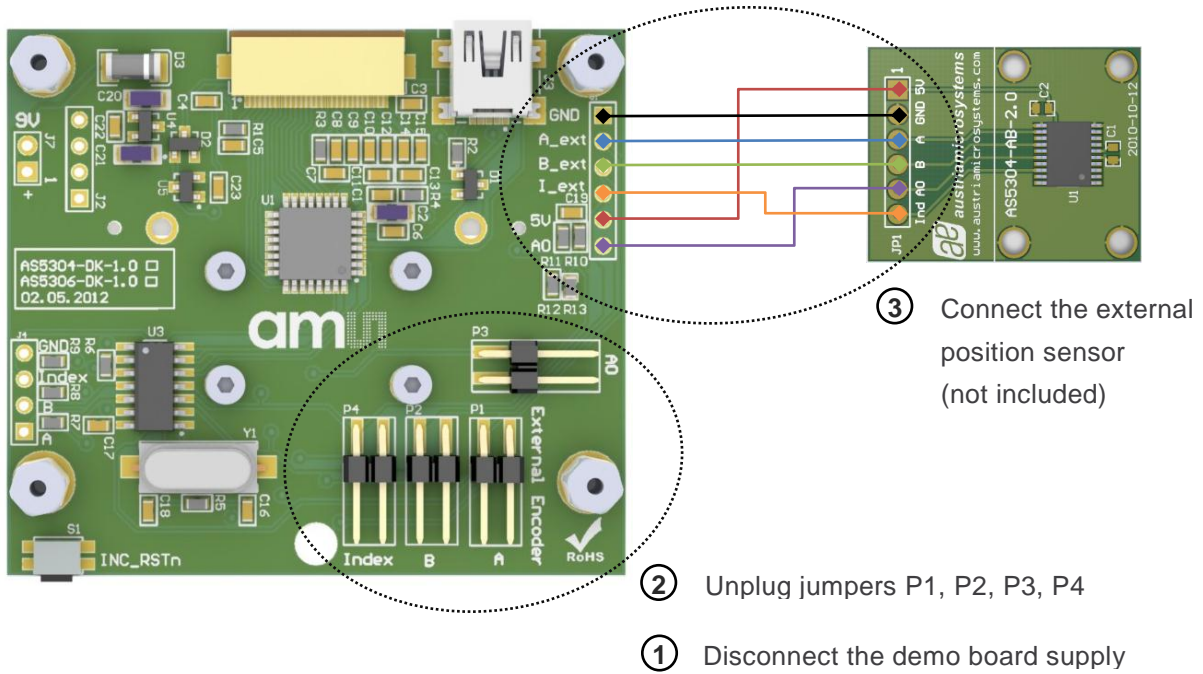

**Multipole Magnet Strip**

The multipole magnet strips provided in the demo kits are made by Arnold Magnetics. The AS5304-DK-ST-1.0 has a pole pair length of 4mm and the AS5306-DK-ST-1.0 has a pole pair length of 2.4mm. The multipole magnet strips are mounted in an aluminum/aluminium slider. See Figure 8 and Table 3 for details.

Find additional information about magnet requirements in the position sensor datasheet.

Figure 8:  
Multipole Magnet Strip

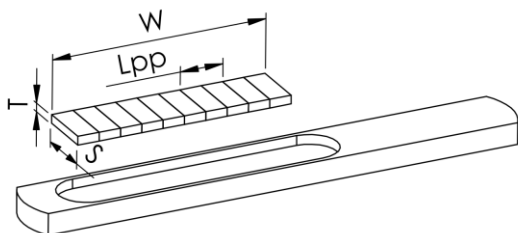

Table 3:  
Demo Kit Magnet

	AS5304-DK-ST	AS5306-DK-ST
W	20 mm	20.4 mm
S	5 mm	5 mm
T	0.8 mm	0.8 mm
Lpp	4 mm	2.4 mm

### 3. How to get the kit running

- (1) Power up the demo board using the USB cable.
- (2) During the start-up of the demo kit, a boot screen is shown offering basic information about position sensor, firmware version and firmware release date. See Figure 9.
- (3) After the start-up the position display is shown. The position display shows the actual position counter value in steps and the calculated position in micrometer. Move the multipole magnet slider. The position change is displayed. See Figure 10.
- (4) Pull out the slider to remove the multi-pole magnet strip. At this point, the LEDs for magnetic field strength and index will indicate a missing magnetic field.
- (5) Fit the slider back into the mechanics. Press “Set Zero” to reset the position output.
- (6) Unplug the USB cable to power down the board.

Figure 9:  
Demo Kit Boot Screen



Figure 10:  
Demo Kit Position Display

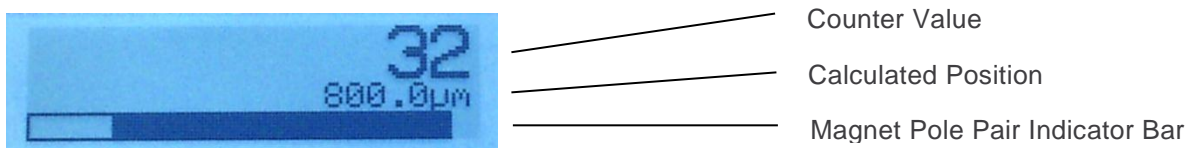



## 4. Design Considerations

Table 4 shows the main features and characteristics of the AS5304A/B and AS5306A/B for linear movement of the multi-pole magnetic strip.

Table 4:  
Position sensor options

Sensor	Magnet Pole Length	Resolution	Linear Speed	Outputs
AS5304A	2.0 mm	25 $\mu$ m	20 m/s	Push Pull
AS5304B	2.0 mm	25 $\mu$ m	20 m/s	Open Drain
AS5306A	1.2 mm	15 $\mu$ m	12 m/s	Push Pull
AS5306B	1.2 mm	15 $\mu$ m	12 m/s	Open Drain

### Magnet type and position

Note that the Hall sensor array is located 1.02 mm off the horizontal chip center towards the row of pins 11...20 as shown in Figure 11.

The magnet strip should be centered over the Hall sensor array.

Figure 11:  
Hall sensor array in package

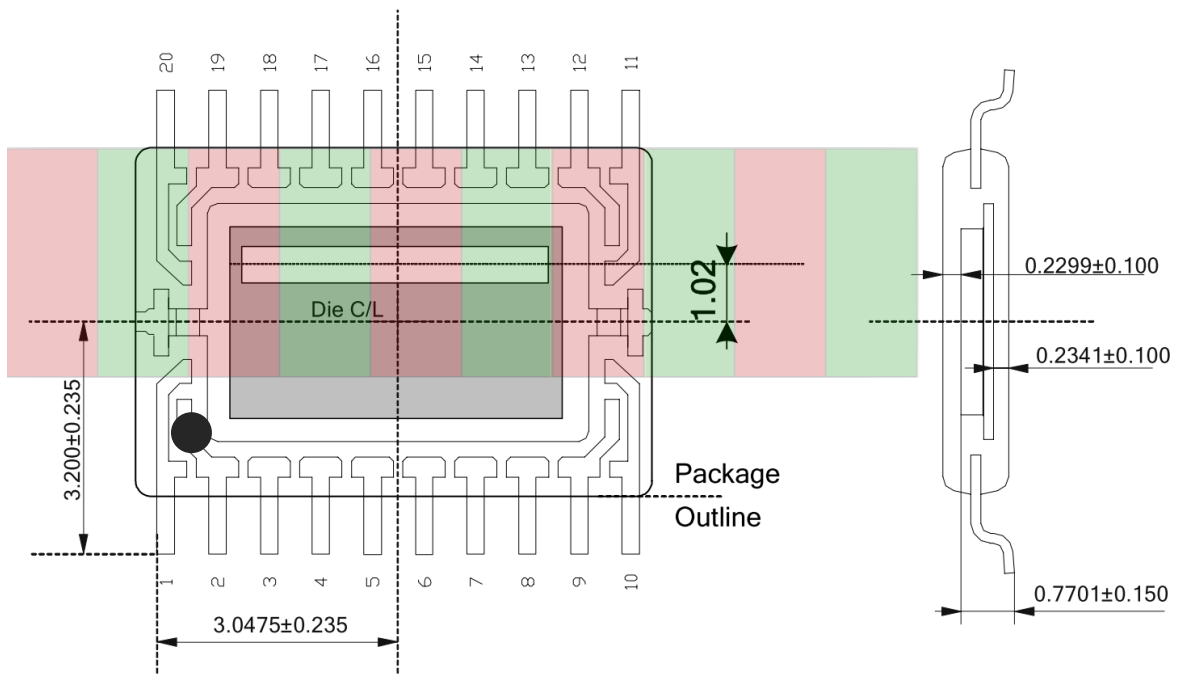

## 5. Schematics and BOM

### Schematics

The main components of the AS5304 / AS5306 demoboard are the onboard position sensor, the quadrature counter, the main microcontroller and the display.

For easy integration of the AS5304 / AS5306, the LS7366 quadrature counter was chosen to interface between position sensor and microcontroller. By using this component, the actual position can be read out directly using the SPI interface.

The Silabs C8051F320 USB microcontroller reads the position steps and calculates the position to show them on the LCD screen.

Find the complete schematic below for reference.

Figure 12:  
Demo board schematic

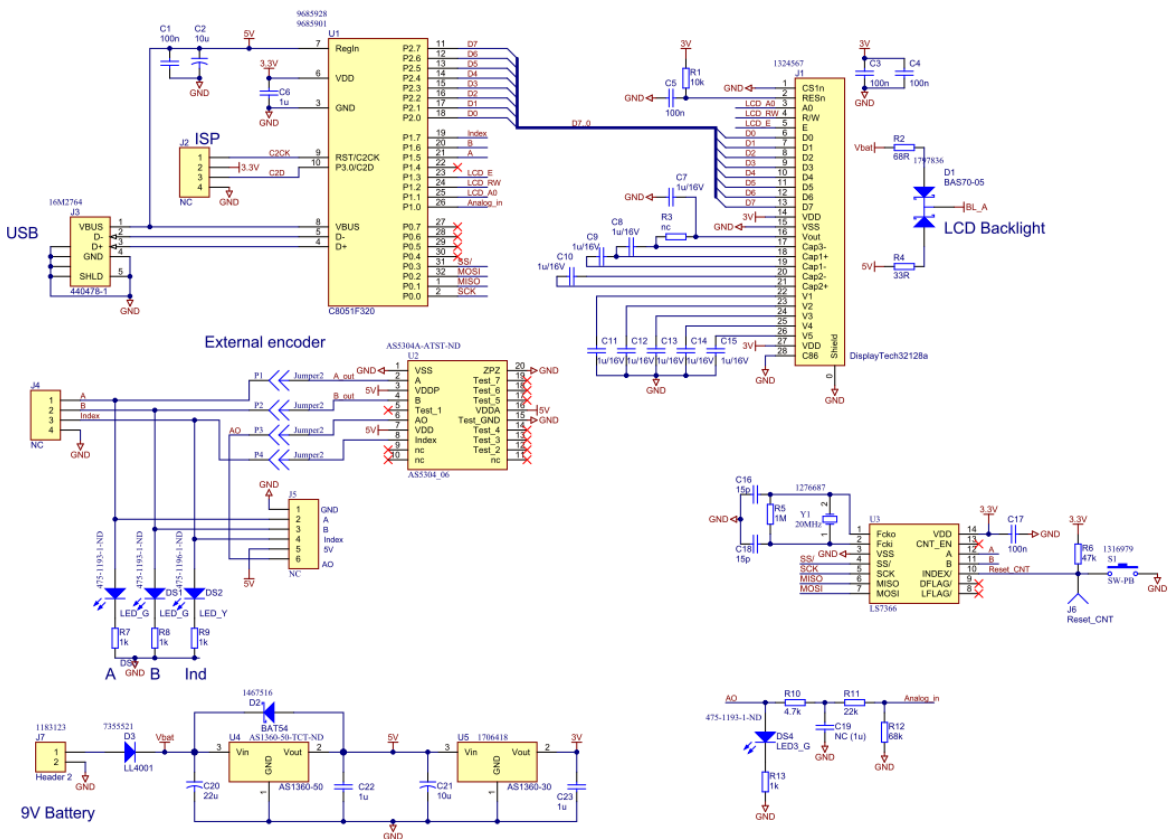

## BOM

Table 5:  
Demo Board BOM

#	Designator	Comment	Footprint	Manufacturer	Quantity
1	*1	Displaytech 32128A-FC-BW-3		Displaytech	1
2	*2, *3, *4, *5	Jumper		TE CONNECTIVITY	4
3	C1, C3, C4, C5, C17	100n	C0603		5
4	C2, C21	10u	Chip_A		2
5	C6, C22, C23	1u	C0603		3
6	C7, C8, C9, C10, C11, C12, C13, C14, C15	1u/16V	C0603		9
7	C16, C18	15p	C0603		2
8	C19	NC (1u)	C0603		1
9	C20	22u	Chip_A		1
10	D1	BAS70-05	SOT23	MULTICOMP	1
11	D2	BAT54	SOT23	FAIRCHILD	1
12	D3	LL4001	MELF	MULTICOMP	1
13	DS1, DS3	LED_G	SMD_LED	OSRAM Opto	2
14	DS2	LED_Y	SMD_LED	OSRAM Opto	1
15	DS4	LED3_G	SMD_LED	OSRAM Opto	1
16	J1	DisplayTech32128a	Tech32128aDisplay	HRS (HIROSE)	1
17	J2, J4	NC	HDR1X4		2
18	J3	440478-1	440478	TE CONNECTIVITY / AMP	1
19	J5	NC	HDR1X6		1
20	J6	NC (Reset_CNT)	PIN1_SMD		1
21	J7	NC (Header 2)	HDR1X2		1
22	P1, P2, P3, P4	Jumper2	Jumper2_Horizontal		4
23	R1	10k	R0603		1
24	R2	68R	R0603		1
25	R3	nc	R0603		1
26	R4	33R	R0603		1
27	R5	1M	R0603		1
28	R6	47k	R0603		1
29	R7, R8, R9	1k	R0603		3
30	R10	4.7k	R0603		1
31	R11	22k	R0603		1
32	R12	68k	R0603		1
33	R13	1k	0603_S		1
34	S1	SW-PB	Multicom_MCPTF	MULTICOMP	1
35	U1	C8051F320	TQFP32	SILICON LABORATORIES	1
36	U2	AS5304_06 A	TSSOP20	ams	1
37	U3	LS7366R-S	SO-G14	US-Digital	1
38	U4	AS1360-50	SOT23	ams	1
39	U5	AS1360-30	SOT23	AMS	1
40	Y1	20MHz	HC49/4H_SMX	IQD FREQUENCY PRODUCTS	1
41	Mechanics	Refer to mechanical drawings			1
42	Screws	M2x6mm (for Mechanics)		NETTLEFOLDS	4
43	Screws	M3x5mm (for Spacer)			4
46	Spacer	M3x6mm		HARWIN	4
47	Magnet	AS5000 MS20-50		Arnold Magnetics	0.2
48	Transportkarton 10-TVS	Use additional foam material			1
49	USB Cable	USB 2.0 Cable Type A -> Type Bmini			1

## 6. Ordering Information

Table 6:  
Ordering Information

Ordering Code	Description	comments
AS5304-DK-1.0	AS5304 Demo Kit	2.0 mm pole length / 25 $\mu$ m step
AS5306-DK-1.0	AS5306 Demo Kit	1.2 mm pole length / 15 $\mu$ m step

## Copyright

Copyright © 1997-2012, ams AG, Tobelbader Strasse 30, 8141 Unterpemstaetten, Austria-Europe. Trademarks Registered ®. All rights reserved. The material herein may not be reproduced, adapted, merged, translated, stored, or used without the prior written consent of the copyright owner.

All products and companies mentioned are trademarks or registered trademarks of their respective companies.

## Disclaimer

Devices sold by ams AG are covered by the warranty and patent indemnification provisions appearing in its Term of Sale. ams AG makes no warranty, express, statutory, implied, or by description regarding the information set forth herein or regarding the freedom of the described devices from patent infringement. ams AG reserves the right to change specifications and prices at any time and without notice. Therefore, prior to designing this product into a system, it is necessary to check with ams AG for current information.

This product is intended for use in normal commercial applications. Applications requiring extended temperature range, unusual environmental requirements, or high reliability applications, such as military, medical life-support or lifesustaining equipment are specifically not recommended without additional processing by ams AG for each application. For shipments of less than 100 parts the manufacturing flow might show deviations from the standard production flow, such as test flow or test location.

The information furnished here by ams AG is believed to be correct and accurate. However, ams AG shall not be liable to recipient or any third party for any damages, including but not limited to personal injury, property damage, loss of profits, loss of use, interruption of business or indirect, special, incidental or consequential damages, of any kind, in connection with or arising out of the furnishing, performance or use of the technical data herein. No obligation or liability to recipient or any third party shall arise or flow out of ams AG rendering of technical or other services.

## Contact Information

### Headquarters

ams AG  
Tobelbader Strasse 30  
8141 Unterpemstaetten  
Austria  
T. +43 (0) 3136 500 0  
For Sales Offices, Distributors and Representatives, please visit:  
<http://www.ams.com/contact>

## X-ON Electronics

Largest Supplier of Electrical and Electronic Components

*Click to view similar products for [Magnetic Sensor Development Tools](#) category:*

*Click to view products by [ams](#) manufacturer:*

Other Similar products are found below :

[AS5045 DB V2](#) [AS5134 AB](#) [MMC5633NJL-B](#) [ROTATEKNOBANGLE2GOTOB01](#) [MIKROE-1647](#) [MIKROE-1646](#) [EVAL-CN0332-PMDZ](#) [AS5510-WL\\_EK\\_DB](#) [ADA4571R-EBZ](#) [AS5170A-SO\\_EK\\_AB](#) [4366](#) [AS5013-QF\\_EK\\_AB](#) [AS5040 AB](#) [AS5040 DB V2](#) [AS5040-SS\\_EK\\_PB](#) [AS5045 AB](#) [AS5047D-TS\\_EK\\_AB](#) [AS5048A-EK-AB-STM1.1](#) [AS5048-TS\\_EK\\_DB](#) [AS5050A-QF\\_EK\\_AB](#) [AS5132 AB](#) [AS5132 DB](#) [AS5132-PB](#) [AS5140 DB](#) [AS5145B-EK-AB-STM1.0](#) [AS5147P-TS\\_EK\\_AB](#) [AS5162-EK-AB](#) [AS5172B-TS\\_EK\\_AB](#) [AS5247-MF\\_EK\\_SB](#) [AS5247U-TQ\\_EK\\_AB](#) [AS5247U-TQ\\_EK\\_SB](#) [AS5311-TS\\_EK\\_AB](#) [AS5510-SOIC8-AB](#) [AS5600-SO\\_EK\\_AB](#) [AS5600-SO\\_EK\\_ST](#) [AS5601-SO\\_EK\\_AB](#) [AS5601-SO\\_EK\\_ST](#) [AS5601-SO\\_RD\\_ST](#) [AS5X47U-TS\\_EK\\_AB](#) [SD4Y-EK-XX](#) [USB I&P BOX](#) [EVAL-CN0323-SDPZ](#) [EVAL-CN0368-SDPZ](#) [DFR0033](#) [OUTOFSHAFTFOR3D2GOTOB01](#) [S2GO3DSENSETLV493DTOB01](#) [S2GOCURSENSETLI4970TOB01](#) [TLE5012BE5000MS2GOTOB01](#) [TLE5012BE9000MS2GOTOB01](#) [TLE5014PROGKITTOB01](#)