



Eval Kit Manual

AS5600

Standard Board

AS5600-SO_EK_ST

Table of Contents

1	Introduction	3
1.1	Kit Content	3
2	Getting Started	3
3	Ordering & Contact Information	6
4	Copyrights & Disclaimer	7
5	Revision Information	8

1 Introduction

The evaluation kit allows an easy and fast evaluation of the AS5600 rotary magnetic position sensor in the lab or together with an existing system. It includes all required material to evaluate all product features.

This small adapterboard is fully assembled with AS5600 position sensor and its necessary external components. All relevant signals are available on a dual-row 2.54mm 4-pin header footprint and can be easily wired to an existing application.

The USB I&P Box is an easy-to use programming and demonstration tool. It can be used to configure the device and to program a configuration.

A small magnet holder and a knob with a magnet attached on its shaft is enclosed to show the functionality of the AS5600.

The AS5600 is a programmable Hall-based rotary magnetic position sensor with a high-resolution 12-bit analog or PWM output for contactless potentiometers. Based on planar Hall technology, this device measures the orthogonal component of the flux density (B_z) from an external magnet while rejecting stray magnetic fields.

The default range of the output is 0 to 360 degrees, but the full resolution of the device can be applied to smaller range by programming a zero angle (start position) and maximum angle (stop position).

The I²C interface is used for configuration and user programming of non-volatile parameters in the AS5600. Additionally the device can be programmed in 3-wire mode without any programmer.

1.1 Kit Content

This kit contains following material listed in Table 1. Additional material can be found on our webpage.

Table 1:
Kit Content

No.	Item	SAP	Info
1	USB I&P Box	990600795	Programming and Interface Box
2	AS5600-SO_EK_AB	990600786	Adapterboard including reference magnet
3	RMH05-DK-XX-1.0	990600534	Rotary Magnet Holder with Knob

For a detailed description of each item please refer to the specific manual. All manuals are available online on the amsAG website.

2 Getting Started

The AS5600 adapter board is ideal for rapid setup of a contactless potentiometer because it includes all necessary tools to operate and configure the AS5600.

This first steps describes how to connect and use the USB I&P Box together with the AS560X Demo Software and the adapter board.

1st Install the AS5600 Demo Software

The Software is located on the USB drive that comes with the USB I&P Box or it can be downloaded from our webpage. After Installation run the software.

2nd Assemble the Hardware Setup

Follow the Instructions shown below in Figure 1 to set-up the kit.

Figure 1:
Setup Instructions

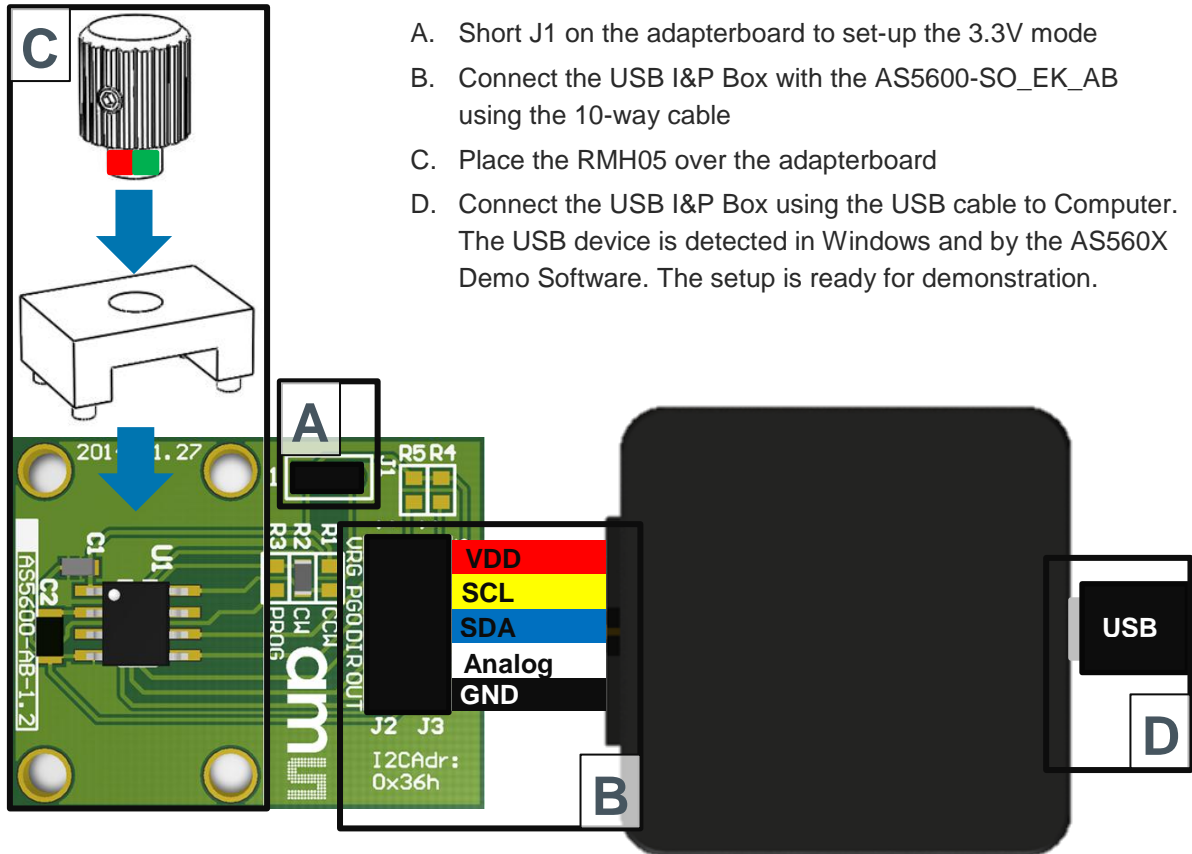

Note: It might be necessary to perform a firmware update on the USB I&P Box if a wrong firmware was detected. In this case, the user will be prompted to allow an automatic firmware upgrade.

3rd Start using the software

Following steps are required to perform a configuration and to read-out the AS5600. Refer to Figure 2 for reference. Read the software user manual for details.

- Perform the desired configuration
- Perform the required angle programming. Use the wizard function for reference.
- Verify the results

Figure 2:
General Software Instructions

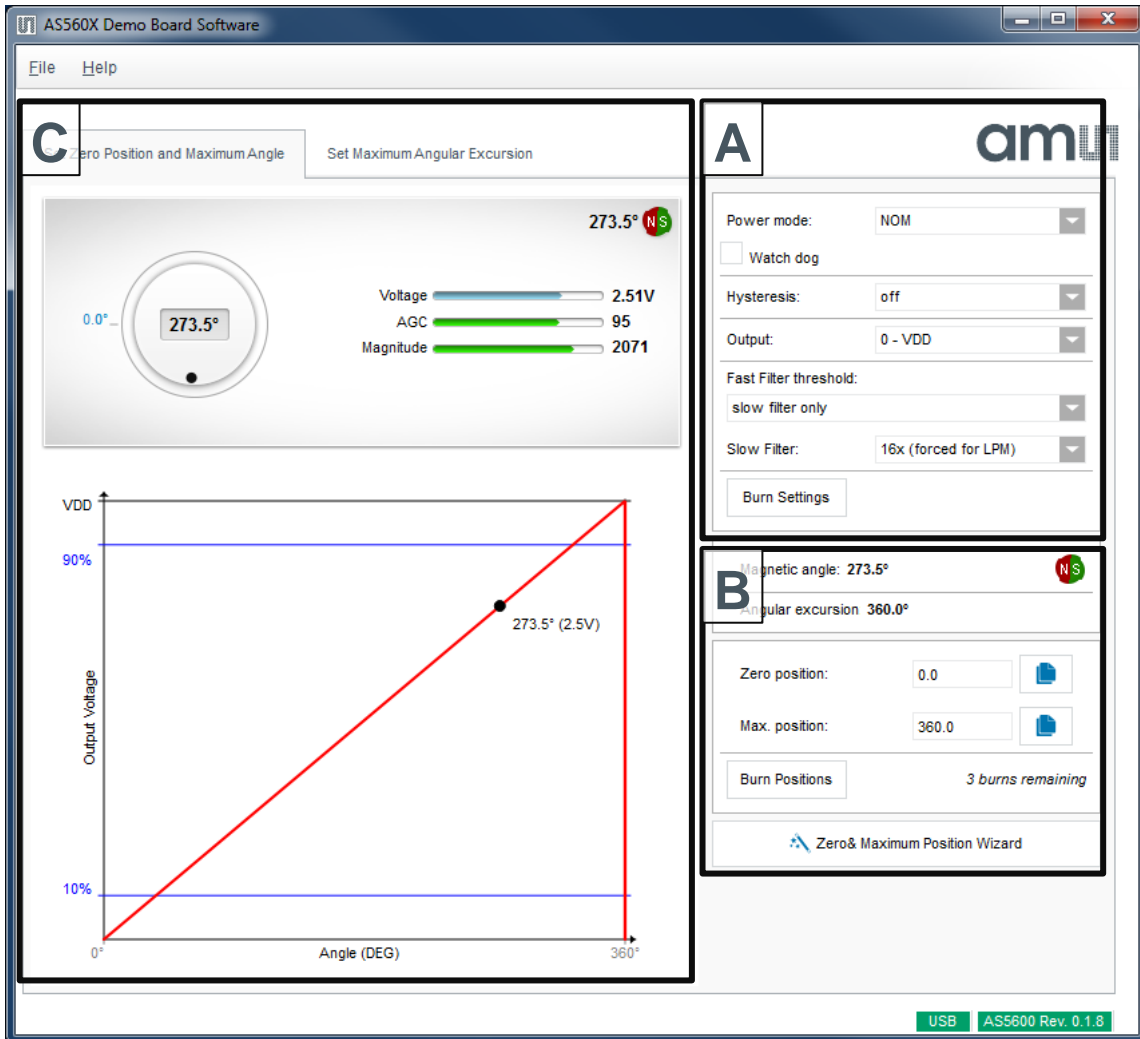

3 Ordering & Contact Information

Ordering Code	Description
AS5600-SO_EK_ST	AS5600 Eval Kit Standard Board

Buy our products or get free samples online at:

www.ams.com/ICdirect

Technical Support is available at:

www.ams.com/Technical-Support

Provide feedback about this document at:

www.ams.com/Document-Feedback

For further information and requests, e-mail us at:

ams_sales@ams.com

For sales offices, distributors and representatives, please visit:

www.ams.com/contact

Headquarters

ams AG

Tobelbaderstrasse 30

8141 Unterpemstaetten

Austria, Europe

Tel: +43 (0) 3136 500 0

Website: www.ams.com

4 Copyrights & Disclaimer

Copyright ams AG, Tobelbader Strasse 30, 8141 Unterpremstaetten, Austria-Europe. Trademarks Registered. All rights reserved. The material herein may not be reproduced, adapted, merged, translated, stored, or used without the prior written consent of the copyright owner.

Demo Kits, Evaluation Kits and Reference Designs are provided to recipient on an “as is” basis for demonstration and evaluation purposes only and are not considered to be finished end-products intended and fit for general consumer use, commercial applications and applications with special requirements such as but not limited to medical equipment or automotive applications. Demo Kits, Evaluation Kits and Reference Designs have not been tested for compliance with electromagnetic compatibility (EMC) standards and directives, unless otherwise specified. Demo Kits, Evaluation Kits and Reference Designs shall be used by qualified personnel only.

ams AG reserves the right to change functionality and price of Demo Kits, Evaluation Kits and Reference Designs at any time and without notice.

Any express or implied warranties, including, but not limited to the implied warranties of merchantability and fitness for a particular purpose are disclaimed. Any claims and demands and any direct, indirect, incidental, special, exemplary or consequential damages arising from the inadequacy of the provided Demo Kits, Evaluation Kits and Reference Designs or incurred losses of any kind (e.g. loss of use, data or profits or business interruption however caused) as a consequence of their use are excluded.

ams AG shall not be liable to recipient or any third party for any damages, including but not limited to personal injury, property damage, loss of profits, loss of use, interruption of business or indirect, special, incidental or consequential damages, of any kind, in connection with or arising out of the furnishing, performance or use of the technical data herein. No obligation or liability to recipient or any third party shall arise or flow out of ams AG rendering of technical or other services.

5 Revision Information

Initial version 1-00

Changes from 0-00 (2014-Jul-2) to current revision 1-00 (2014-Jul-2)	Page
Initial version	

Note: Page numbers for the previous version may differ from page numbers in the current revision.

X-ON Electronics

Largest Supplier of Electrical and Electronic Components

Click to view similar products for [Magnetic Sensor Development Tools](#) category:

Click to view products by [ams](#) manufacturer:

Other Similar products are found below :

[AS5045 DB V2](#) [AS5134 AB](#) [MMC5633NJL-B](#) [ROTATEKNOBANGLE2GOTOBO1](#) [MIKROE-1647](#) [MIKROE-1646](#) [EVAL-CN0332-PMDZ](#) [AS5510-SO_EK_AB](#) [AS5510-WL_EK_DB](#) [ADA4571R-EBZ](#) [AS5170A-SO_EK_AB](#) [4366](#) [AS5013-QF_EK_AB](#) [AS5040 AB](#) [AS5040 DB V2](#) [AS5040-SS_EK_PB](#) [AS5047D-TS_EK_AB](#) [AS5048A-EK-AB-STM1.1](#) [AS5048A-TS_EK_AB](#) [AS5048-TS_EK_DB](#) [AS5050A-QF_EK_AB](#) [AS5132 AB](#) [AS5132 DB](#) [AS5132-PB](#) [AS5140 DB](#) [AS5145B-EK-AB-STM1.0](#) [AS5147P-TS_EK_AB](#) [AS5162-EK-AB](#) [AS5172B-TS_EK_AB](#) [AS5247-MF_EK_SB](#) [AS5247U-TQ_EK_AB](#) [AS5247U-TQ_EK_SB](#) [AS5262-MF_EK_AB](#) [AS5311-TS_EK_AB](#) [AS5510-SOIC8-AB](#) [AS5600-SO_EK_AB](#) [AS5600-SO_EK_ST](#) [AS5601-SO_EK_AB](#) [AS5601-SO_EK_ST](#) [AS5601-SO_RD_ST](#) [AS5X47U-TS_EK_AB](#) [SD4Y-EK-XX](#) [USB I&P BOX](#) [EVAL-CN0323-SDPZ](#) [EVAL-CN0368-SDPZ](#) [DFR0033](#) [OUTOFSHAFTFOR3D2GOTOBO1](#) [S2GO3DSENSETLV493DTOBO1](#) [S2GOCURSENSETLI4970TOBO1](#) [TLE5012BE5000MS2GOTOBO1](#)