

SL900A

EPC Class 3 Sensory Tag Chip - For Automatic Data Logging

General Description

The SL900A is an EPC global Class 3 sensory tag chip optimized for single-cell and dual-cell, battery-assisted smart labels with sensor functionality. The chip is ideal for applications using thin and flexible batteries but can also be powered from the RF field (electromagnetic waves from an RFID reader).

The chip has a fully integrated temperature sensor with a typical nonlinearity of $\pm 0.5^{\circ}\text{C}$ over the specified temperature range. The external sensor interface provides a flexible way of adding additional sensors to the system and supports up to 2 external sensors.

Ordering Information and Content Guide appear at end of datasheet.

Key Benefits & Features

The benefits and features of SL900A, EPC Class 3 Sensory Tag Chip - For Automatic Data Logging are listed below:

Figure 1:
Added Value of using SL900A

Benefits	Features
Versatile temperature and data logging	High Temperature Range: -40°C to $+125^{\circ}\text{C}$
Worldwide EPC compliant	Frequency: 860 to 960 MHz
Works fully passive or in BAP mode	Battery supply: 1.5V or 3V
Programmable logging modes with various sensors	Data logging from: <ul style="list-style-type: none"> On-chip temperature sensor 2 external sensors
Works with EPC readers	EPC Class 1 and Class 3 Compliant
Provides supply for external sensors	Energy harvesting from reader field
Autonomous data logging with timestamp	Real-time clock for data logging
Sensor alert function	External sensor interrupt capability
Supports fast communication via SPI	Serial peripheral interface
Storage for up to 841 events with timestamps	On-chip 9k bit EEPROM
Alert for shelf life expiration	Integrated dynamic shelf life calculation
Programmable sensor limits	Advanced logging with 4 user-selectable limits

Package Options

The available SL900A package options are:

- 16-pin QFN (5 x 5 mm)
- Tested wafer (8")

Applications

The SL900A device is ideal suited for:

- Monitoring and tracking of temperature-sensitive products
- Temperature monitoring of medical products
- Pharmaceutical logistics
- Monitoring of fragile goods transportation
- Dynamic Shelf Life applications
- RFID to SPI interface

Block Diagram

The functional blocks of this device for reference are shown below:

Figure 2:
SL900A Block Diagram

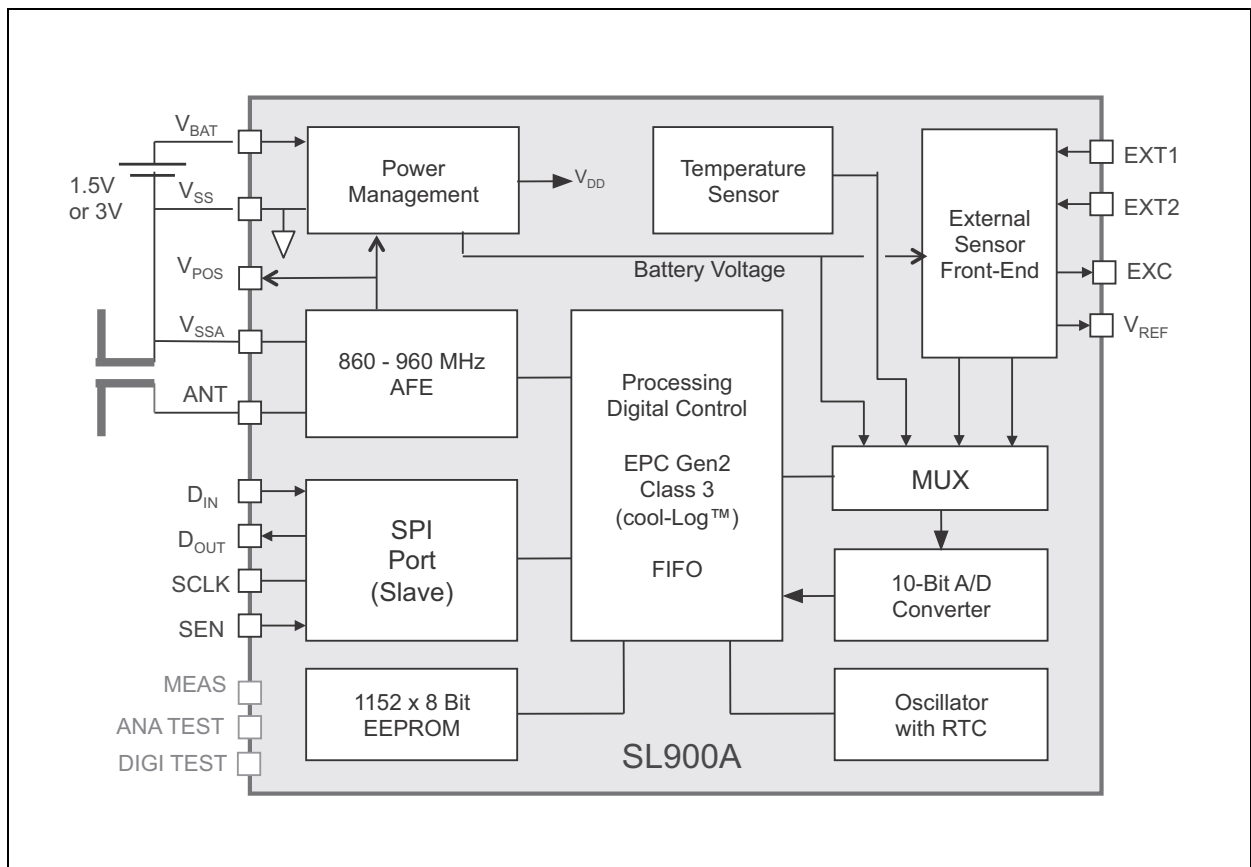

SL900A Block Diagram: Basic block diagram of SL900A

Pin Assignment

The SL900A pin assignments are described below.

Figure 3:
Pin Layout

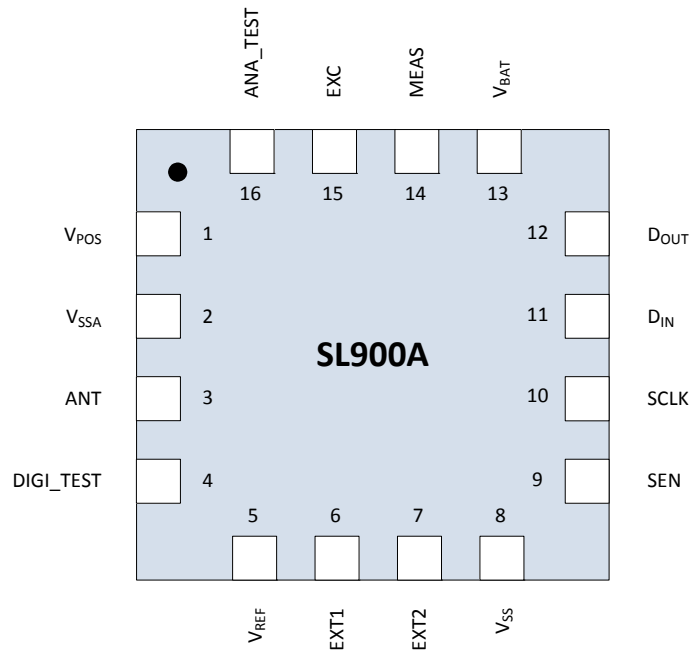

Figure 4:
Pin Description

Pin Number	Pin Name	Description
1	V _{POS}	RF rectifier output
2	V _{SSA}	Chip substrate ground – connect to antenna ground
3	ANT	Antenna coil
4	DIGI_TEST	Test input – must be left open
5	V _{REF}	Reference voltage output (Vo2)
6	EXT1	Analog input for external sensor
7	EXT2	Analog input for external sensor
8	V _{SS}	Chip substrate ground – connect to negative battery terminal. Recommended to connect to V _{SSA} !
9	SEN	Enable input for the SPI interface
10	SCLK	SPI clock
11	D _{IN}	SPI data input
12	D _{OUT}	SPI data output

Pin Number	Pin Name	Description
13	V _{BAT}	Positive supply input
14	MEAS	Test pin for use during test – must be left open
15	EXC	Supply voltage for the external sensors or a AC signal source for external sensors
16	ANA-TEST	Analog test pin – must be left open

Pin Description: This table shows a detailed pin description of the SL900A.

Bare Die Pad Layout

Figure 5:
Pad Location Diagram

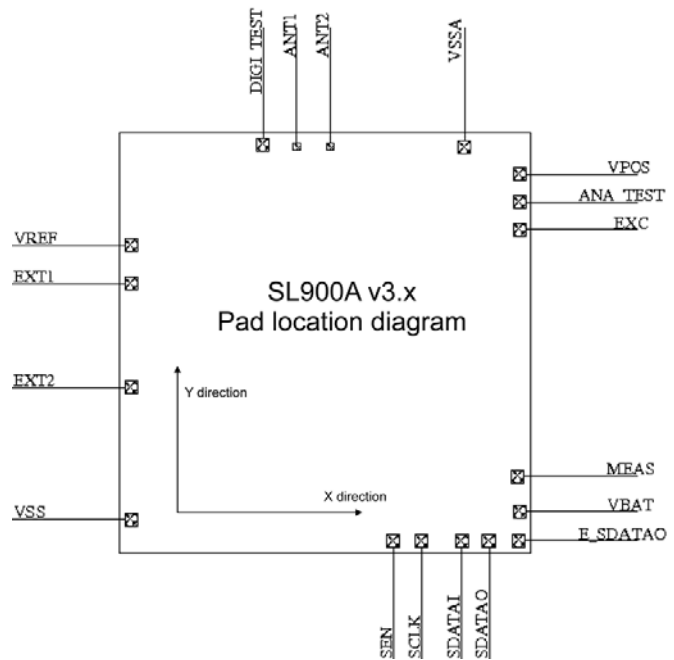

Figure 6:
Pad Parameters

Pad name	X position (μm)	Y position (μm)	Pad window (μm)	Type
V _{REF}	77.5	2040.5	85 x 85	Analog Output
EXT1	77.5	1787.5	85 x 85	Analog Input/Output
EXT2	77.5	1098.5	85 x 85	
V _{SS}	77.5	223.5	85 x 85	Supply
S _{EN}	1822.5	77.5	85 x 85	Digital Input
SCLK	2005.5	77.5	85 x 85	
SDATAI	2271.5	77.5	85 x 85	
SDATAO	2454.5	77.5	85 x 85	Digital Output
E_SDATAO	2653.5	82.5	85 x 85	Test Pad
V _{BAT}	2657.5	275.5	85 x 85	Supply
MEAS	2648.3	509.15	85 x 85	Test Pad
EXC	2657.5	2144.5	85 x 85	Analog Output
ANA_TEST	2657.5	2327.5	85 x 85	Test Pad
V _{POS}	2657.5	2510.5	85 x 85	Analog Output
V _{SSA}	2292	2689.5	85 x 85	Supply
ANT2	1396	2696	See RF pad drawing	Radio-frequency Pad,
ANT1	1177	2694	See RF pad drawing	
DIGI_TEST	955	2707.5	85 x 85	Test Pad

Pad locations: Pad locations are measured from lower left chip edge to pad centre.

Absolute Maximum Ratings

Stresses beyond those listed under “Absolute Maximum Ratings” may cause permanent damage to the device. These are stress ratings only. Functional operation of the device at these or any other conditions beyond those indicated under “Operating Conditions” is not implied. Exposure to absolute maximum rating conditions for extended periods may affect device reliability.

Figure 7:
Absolute Maximum Ratings (Operating free-air temperature range, unless otherwise noted)

Parameter	Min	Max	Units	Comments
Input Voltage Range	-0.3	3.7	V	All voltage values are with respect to substrate ground terminal V _{SS}
Maximum Current V _{POS} , ANT		100	mA	
ESD Rating, HBM (all pins except ANT)		2	kV	
ESD Rating, HBM (RF input pin ANT)		500	V	
Maximum Operating Virtual Junction Temperature, T _J		+150	°C	
Storage Temperature Range, T _{stg}	-65	+150	°C	
Lead Temperature (soldering, 10 sec.)		+260	°C	

Absolute Maximum Ratings: This figure shows the absolute maximum ratings of the SL900A.

Electrical Discharge Sensitivity

This integrated circuit can be damaged by ESD. We recommend that all integrated circuits are handled with appropriate precautions. Failure to observe proper handling and installation procedures can cause damage. ESD damage can range from subtle performance degradation to complete device failure.

Precision integrated circuits may be more susceptible to damage because very small parametric changes could cause the device not to meet the published specifications. RF integrated circuits are also more susceptible to damage due to use of smaller protection devices on the RF pins, which are needed for low capacitive load on these pins.

Operating Conditions

Figure 8:
Operating Conditions

Symbol	Parameter	Min	Typ	Max	Units
V _{BAT}	Input Supply Voltage	1.2	1.5	3.6	V
T _A	Operating ambient temperature range	-40		+125	°C

Electrical Characteristics

All limits are guaranteed. The parameters with min and max values are guaranteed with production tests or SQC (Statistical Quality Control) methods.

$T_A = -40^{\circ}\text{C}$ to $+125^{\circ}\text{C}$, $V_{\text{BAT}} = 1.5\text{V}$, unless otherwise noted.

Typical values are at $T_A = 25^{\circ}\text{C}$ ⁽¹⁾.

Figure 9:
Electrical Characteristics

Symbol	Parameter	Conditions	Min	Typ	Max	Units
V_{BAT}	Operating Input Voltage	$T_A = 25^{\circ}\text{C}$	1.2		3.6	V
$V_{\text{BAT(SU)}}$	Minimum Start-Up Input Voltage	$T_A = 25^{\circ}\text{C}$		1.3		V
$I_{\text{BAT-OP15}}$	Operating Current into V_{BAT}	Temperature conversion, $V_{\text{BAT}}=1.5\text{V}$		200	250	μA
$I_{\text{BAT-OP30}}$	Operating Current into V_{BAT}	Temperature conversion, $V_{\text{BAT}}=3\text{V}$		290	350	μA
$I_{\text{BAT-Q}}$	Quiescent Current into V_{BAT}	$V_{\text{BAT}} = 1.5\text{V}$; timer running		1.6		μA
$I_{\text{BAT-SD}}$	Shutdown Current into V_{BAT}	$V_{\text{BAT}} = 1.5\text{V}$		0.5		μA
I_{EXT}	Maximum Current from V_{POS} pin	In electromagnetic field		200		μA
$V_{\text{POS-I}}$	V_{POS} limiter point	In electromagnetic field		3.4		V
ANTI-QFN	Antenna pad impedance	Measured at 900MHz, QFN package for PCB assembly		31-j3 20		Ω
ANTI-DIE	Antenna pad impedance	Measured at 900MHz, bare die for inlay assembly		9-j33 0		Ω
ANTS	Antenna pad sensitivity	Measured at 900MHz, battery assisted mode		-15		dBm
V_{IL}	Voltage Input Threshold, Low (SEN, SCLK, DIN)	$V_{\text{BAT}} = 1.5\text{V}$		0.4		V
		$V_{\text{BAT}} = 3\text{V}$		1		V
V_{IH}	Voltage Input Threshold, High (SEN, SCLK, DIN)	$V_{\text{BAT}} = 1.5\text{V}$		1		V
		$V_{\text{BAT}} = 3\text{V}$		2.1		V

Symbol	Parameter	Conditions	Min	Typ	Max	Units
V_{OL}	Voltage Output Threshold, Low D_{OUT} pin	$V_{BAT} = 1.5V, I_{DOUT} = 1mA$	V_{SS}		450m	V
		$V_{BAT} = 3V, I_{DOUT} = 1mA$	V_{SS}		300m	V
V_{OH}	Voltage Output Threshold, High D_{OUT} pin	$V_{BAT} = 1.5V, I_{DOUT} = -1mA$	1		V_{BAT}	V
		$V_{BAT} = 3V, I_{DOUT} = -1mA$	2.7		V_{BAT}	V
f_{SCLK}	SCLK serial data clock	$V_{BAT} = 1.5V$			1	MHz
		$V_{BAT} = 3V$			5	MHz
f_c	Carrier Frequency		860		960	MHz
T_{S-R}	Temperature Sensor Range		-20		60	°C
$T_{S-R EXT}$	Extended temperature sensor range with reduced accuracy		-40		+125	°C
T_{S-NL}	Temperature sensor nonlinearity	Inside T_{S-R}		± 0.5		
T_{S-A}	Temperature Sensor Accuracy	Inside T_{S-R}		± 1		°C
t_{sens}	Measurement interval	Programmable	1		32,768	Sec
t_{RTC-I}	Real-Time Clock, Interval			1		Sec
t_{RTC-A}	Real-Time Clock, Accuracy	Over specified T_{S-R} temperature range	-3		+3	%
t_{RTC-CA}	Real-Time Clock, Calibration Accuracy	$T_A = 35^\circ C$	-0.2		+0.2	%

Symbol	Parameter	Conditions	Min	Typ	Max	Units
$t_{\text{RTC-B}}$	Real-time Clock, Accuracy	$V_{\text{BAT}}=1.3\text{V} \sim 3\text{V}$		± 3		%
$t_{\text{RTC-C}}$	Real time clock, Accuracy	$V_{\text{BAT}}= 1.2\text{V}\sim 1.3\text{V};$ $3\text{V}\sim 3.6\text{V}$	-7		+5	%
EW_{CYC}	EEPROM Erase/Write Cycles	$T_{\text{A}} = 25^{\circ}\text{C}$	100,000			Cycles
t_{DR}	EEPROM Data Retention Time	$T_{\text{A}} = 125^{\circ}\text{C}$	20			Years
$t_{\text{E/W}}$	EEPROM Erase/Write Speed		7		7.5	ms
r_{EXC}	EXC pin output resistance	EXC internally connected to V_{BAT} for ext. sensor supply		400		Ω
r_{EXT}	External sensor interface pads resistance (EXT1, EXT2, V_{REF})			200		Ω

Note(s) and/or Footnote(s):

1. Limits are 100% production tested at $T_{\text{A}} = 35^{\circ}\text{C}$. Limits over the operating temperature range are guaranteed by design.

Short Description

The SL900A is designed for use in smart active labels (SAL), semi-passive labels and passive labels. Smart active labels are defined as thin and flexible labels that contain an integrated circuit and a power source. SAL includes in its definition both “fully active” smart labels, and semi-active smart labels, also known as battery-assisted back-scattered passive labels, both of which enable enhanced functionality and performance over passive labels. The IC includes sensor functionality and logging of sensor data (see [Figure 10](#) below).

The SL900A is operating at 860 to 960 MHz and is fully EPC global Class 1 compliant. The chip is supplied from a single-cell battery of typically 1.5V, or from a dual cell battery (3V). The on-chip temperature sensor and real-time clock (RTC) accommodate temperature data logging.

Supply Arrangement

The SL900A is supplied from either the battery or through the electromagnetic waves from a reader. The device is normally supplied from the battery unless there is no battery attached (passive label), or when the battery is drained.

Figure 10:
Block Diagram

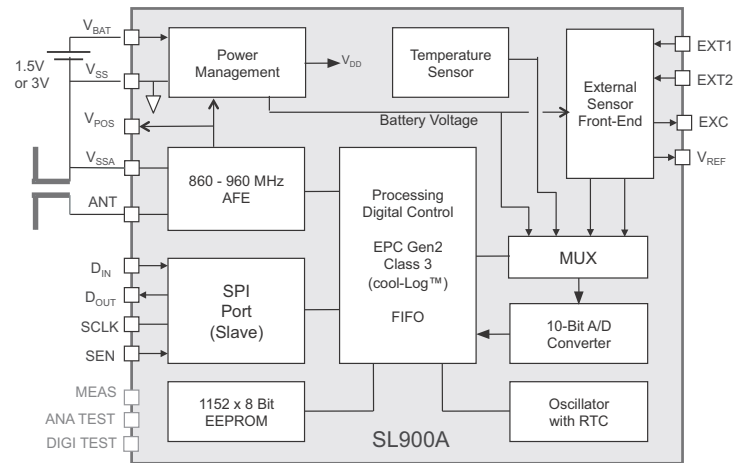

Analog Front End (AFE)

The analog front end is designed according to EPC Gen 2. The forward link (reader to tag) is amplitude modulated and the backward link (tag to reader) is amplitude modulated (load modulation is used).

Processing and Digital Control

The SL900A is fully EPC Class 1 compliant, with additional custom commands for extended functions. The maximum transponder to interrogator data rate according to Class 1/Gen.2 is 640 kbit/s. The maximum interrogator to transponder data rate is 160 kbit/s.

Figure 11:
Supported Data Rates

Data Rate	Min	Max
Interrogator to transponder	40 kbit/s	160 kbit/s
Transponder to interrogator	5 kbit/s	640 kbit/s

Serial Interface (SPI)

The integrated serial interface (SPI) can be used to initialize the chip and to set the parameters. The logging procedure can be started and stopped with the SPI. The SPI bus can also be used for the communication between a microcontroller that is attached to the SL900A and the RFID reader.

Real-Time Clock (RTC)

The on-chip real-time clock (RTC) is started through the START LOG command in which the start time is programmed in UTC format. The interval for sensing and data logging can be programmed in the range from 1 second up to 9 hours. The accuracy of the timer is $\pm 3\%$. The timer oscillator is calibrated at 35 °C within $\pm 0.2\%$.

Temperature Sensor

The on-chip temperature sensor can measure the temperature in the range from -20°C to 60°C with a typical accuracy of $\pm 1^\circ\text{C}$. The full temperature range of -40°C to +125°C has a reduced accuracy.

External Sensors

The on-chip external sensor front end provides a flexible interface for analog external sensors. It has an auto-range and interrupt function. It supports various types of analog sensors from pressure, humidity, temperature, light ...

Analog to Digital Converter

The chip has an integrated 10-bit analog to digital converter with selectable voltage references. It is used for conversion of temperature, external sensors and battery voltage.

External Sensor Interrupt

The external sensor inputs EXT1 and EXT2 can be used for event-triggered logging. In this mode, the logging is not triggered in predefined time intervals from the internal timer, but can be triggered externally, either with a sensor, switch or a microcontroller.

The interrupt source can be the EXT1, EXT2 input or both, were the EXT1 input has the higher priority. The user application can select which measurements are triggered by the interrupt event.

In the interrupt mode, the sensor value is stored together with the 32-bit real time clock value. For a correct real-time clock value, the correct Start time has to be supplied. The interrupt mode is started with the START LOG command and the correct setting in the registers (SET LOG MODE command).

Data Protection

Additional to the Gen2 lock protection, the SL900A offers read/write protection using 3 password sets for 3 memory areas. Each 32-bit password is divided into 2 16-bit passwords, where the lower 16 bits are reserved for the Write protection and the higher 16 bits are reserved for the Read/Write protection.

Shelf Life

The SL900A device has an integrated shelf life algorithm that can dynamically calculate the remaining shelf life of the product. It has an automatic alarm function for the shelf life expiration. This can be used to directly drive a LED or as an interrupt for an external microcontroller.

Memory arrangement

The SL900A device has an integrated 9kbit EEPROM. It is organized into 5 memory banks shown below.

Figure 12:
Memory Arrangement

Memory Bank	Bank Size (bits)	Comments
SYSTEM	512	System parameters like calibration data and log parameters
RESERVED	64	Access and Kill password
EPC	144	PC and EPC value
TID	80	Unique identifier – programmed and locked during production
USER	8416	User and measurement data

System Description

Figure 14 shows the different states and their interactions.
Figure 22 shows the command overview.

Initializing the Chip

A virgin chip (not initialized) can be initialized either through the SPI port or through the electromagnetic field from a reader in the standby mode. The power source is either from a battery (V_{BAT}) or extracted from the RF field via the AFE circuit. After the initializing procedure, the chip will enter the ready mode.

Power Modes

Ready Mode

In the ready mode, all parameters can be set, read and changed through a reader with the appropriate passwords.

Active Mode

In active mode, the real-time clock (RTC) is running, the desired parameters are set, and the on-chip temperature sensor is in standby.

Logging Mode

A log flag from the timer will enable the logging mode in which the sensor and the A/D converter will be activated, and the measured value will be stored in the EEPROM together with the time of the event. If the external sensor flag is set, the external sensors will also be activated and the measured data stored. The A/D converter can be multiplexed between internal temperature sensor, external sensors or battery voltage. After the event, the chip will return to the active mode.

Interrupt Mode

In the interrupt mode, the external sensor interrupt block is running with minimal power consumption. When the external sensor value exceeds a specified threshold, the chip goes into the logging mode where the selected sensor values and real time of the event are stored to the EEPROM.

Stand-by Mode

In passive mode, all blocks in the chip are turned off and only the leakage current is flowing. When the label enters an RF field, it will go from Stand-by mode to Ready mode. If the SEN pin rises high, the chip will go from the Stand by mode to the serial mode

Figure 13:
Modes of Operation

Mode	Description	IBAT (Typ.)	Power from AFE
Stand-by	In passive mode the chip is turned off and only the leakage current is flowing	0.1 μ A	No
Serial	Enables initializing and executing of all commands via the SPI bus	50 μ A	No
Ready	Chip is initialized and all commands can be executed via the reader	50 μ A	Yes
Active	<ul style="list-style-type: none"> • RTC running • Sensor standby 	2 μ A	No
Interrupt	<ul style="list-style-type: none"> • RTC running • External sensor minimum supply 	2.5 μ A	No
Logging	<ul style="list-style-type: none"> • Sensor reading (on-chip temperature sensor, battery voltage level and/or external sensor through the MMI pin) • Measured data stored in EEPROM • RTC time stored in EEPROM 	180 μ A	No

State Diagram

Figure 14:
State Transition Diagram

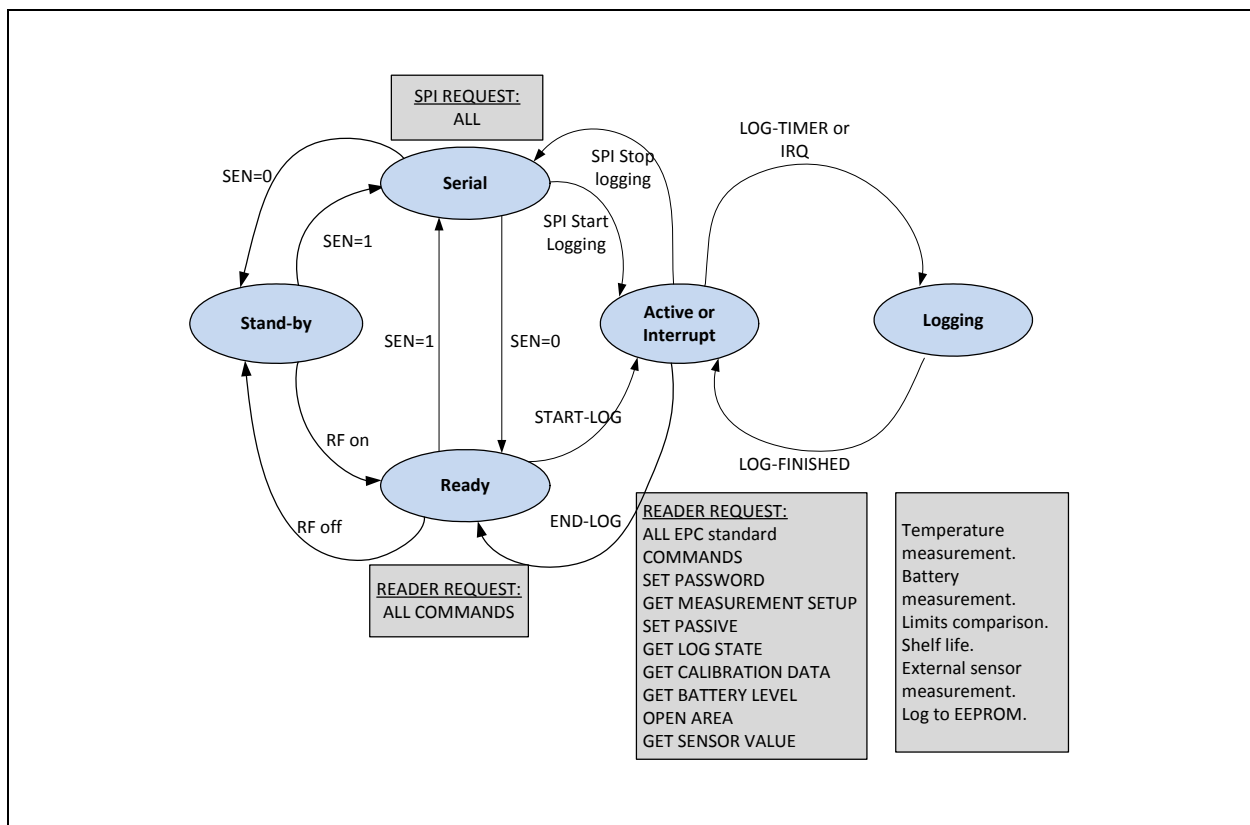

Data Protection

Additional to the Gen2 lock protection, the SL900A offers read/write protection using 3 password sets for 3 memory areas. The System area is protected by the System password, the Application area is protected by the Application password, and the Measurement area is protected by the Measurement password. Each 32-bit password is divided into 2 16-bit passwords, where the lower 16 bits are reserved for the Write protection and the higher 16 bits are reserved for the Read/Write protection.

The password can be set either with the custom RFID command SET PASSWORD, or through the SPI, by writing the password to the password locations.

The password protection is activated immediately after the SET PASSWORD command. In case the passwords are written with the SPI interface, the protection is activated when the transponder re-enters an RF field.

Password protection does not block any read/write operation on the SPI interface; it is active only for the RFID interface.

Figure 15:
Password Storage in System Memory

Address	Data	Function
0x000	System Password [31:24]	System Password – read/write protect
0x001	System Password [23:16]	
0x002	System Password [15:8]	System Password - write protect
0x003	System Password [7:0]	
0x004	Application Password [31:24]	Application Password – read/write protect
0x005	Application Password [23:16]	
0x006	Application Password [15:8]	Application Password - write protect
0x007	Application Password [7:0]	
0x008	Measurement Password [31:24]	Measurement Password – read/write protect
0x009	Measurement Password [23:16]	
0x00A	Measurement Password [15:8]	Measurement Password - write protest
0x00B	Measurement Password [7:0]	

Data Log Functions

The SL900A device supports various flexible data log formats. The data log format depends on the Logging form. The data log formats are defined in [Figure 23](#).

The Logging form is set with the SET LOG MODE command and is stored in "Logging form [2:0]" (SPI address 0x026) bits in the EEPROM.

Figure 16:
Supported Logging Formats

Bit 2	Bit 1	Bit 0	Logging From	Description
0	0	0	Dense	All values are stored to the measurement area. No additional time information is stored to the measurement area.
0	0	1	All values out of limits	All values that are out of the specified limits are stored to the measurement area. Additional to the sensor value, also the measurement number is stored, so the application can reconstruct the time-sensor points.
0	1	1	Limits crossing	Only the crossing point of each limit boundary is stored. Additional to the sensor value, also the measurement number is stored, so the application can reconstruct the time-sensor points.
1	0	1	IRQ, EXT1	Interrupt triggered on the EXT1 external sensor input. At each trigger event the selected sensor values are stored. Additional to the sensor values, also the real-time clock offset is stored.
1	1	0	IRQ, EXT2	Interrupt triggered on the EXT2 external sensor input. At each trigger event the selected sensor values are stored. Additional to the sensor values, also the real-time clock offset is stored.
1	1	1	IRQ, EXT1, EXT2	Interrupt triggered on the EXT1 and EXT2 external sensor input. At each trigger event the selected sensor values are stored. Additional to the sensor values, also the real-time clock offset is stored.

When the "IRQ + timer enable" bit (Initialize command, SPI address 0x02A) is set to 1, the logging will be triggered on the selected time interval (timer) and also on an interrupt from external sensor1, sensor 2 or both – depending on the selected logging mode.

The Storage rule bit defines what happens when the logging area in the EEPROM is full.

Figure 17:
Storage Rule

Bit	Storage Rule	Description
0	Normal	When the logging area in the EEPROM is full, the chip does not store any new sensor data to the EEPROM, but it will still increment the measurement counter and RTC.
1	Rolling	When the logging area is full, the chip continues with writing new sensor data to the EEPROM from the beginning of the logging area. Thus the chip overwrites the old stored data and increments the "Number of memory replacements [5:0]" field in the System status group.

Limits Counter

The Limits counter can be used as an advanced alarm mechanism. It is enabled in all log formats and it will display the cumulative number of measurements that are outside limits. The application does not have to read the whole EEPROM content in order to determine if the temperature limits have been exceeded, just the Limits counter block. The Limits counter block can be read out with the GET LOG STATE command.

The system uses 4 limits that can be set by the user:

- Extreme upper limit
- Upper limit
- Lower limit
- Extreme lower limit

There is a dedicated 8-bit counter for each of the 4 limits in the Limits counter block. The appropriate counter will increment each time a sensor value is outside a limit.

The user can select which sensor will be used in the limits comparison. The internal temperature sensor is selected by default. Other sensors can be selected with the SET SFE PARAMETERS command with the "Verify sensor ID[1:0]" field (SPI address 0x018):

Figure 18:
Modes of Operation

Verify Sensor ID Bit 1	Verify Sensor ID Bit 0	Sensor Selected for Limits Comparison
0	0	Internal temperature sensor - DEFAULT
0	1	External sensor 1
1	0	External sensor 2
1	1	Battery voltage

Logging Timer

The SL900A device has an integrated RC oscillator that is calibrated to 1024Hz. This oscillator drives the logging timer. The logging timer resolution is 1 second. The maximum period is 9.1 hours (32768 seconds). The logging interval is programmed with the SET LOG MODE command.

The measurement real time is derived from 4 parameters - the Start time (ST), the Delay time (DT), the log interval (LT), and the # of the measurement (NM). This value has to be calculated in the reader by the equation:

$$\text{Real time} = \text{ST} + \text{DT} + \text{LT} * \text{NM}$$

Delay Time

The SL900A supports delayed start of the logging procedure. The Delay time has a resolution of 8 minutes - 32 seconds (512 seconds) and a maximum value of 582 hours (12 bits). The delay time value is set with the Initialize command, while the Delay time counter starts counting when the device receives the START LOG command.

The delay time can also be disabled and an external push button can be used for starting the logging procedure.

Analog to Digital Conversion

The chip has an integrated analog to digital converter with 10-bit resolution and selectable voltage references. By default, the references are selected as: Vo1 = 0V and Vo2 = 310mV. This results in a voltage input range of 310mV ~ 620mV, for the temperature conversion this is -89.3°C ~ +94.6°C.

The voltage references are individually selectable in 50mV steps with a fine adjustment for offset calibration. Additionally, the Vo1 reference voltage can be tied directly to ground if the bit "gnd_switch" in the SET CALIBRATION DATA command is set to 1 (SPI address 0x012).

Figure 19:
AD Reference Voltages

Calib. Code	Vo1	Vo2
0b000	160mV	260mV
0b001	210mV	310mV
0b010	260mV	360mV
0b011	310mV	410mV
0b100	360mV	460mV
0b101	410mV	510mV
0b110	460mV	560mV
0b111	510mV	610mV

The Vo2 voltage defines the lower temperature limit for the temperature conversion – note that normal operation is not guaranteed below -40 °C.

Figure 20:
Theoretical Lower Temperature Limit

Vo2	Low. Temp. Lim.
260mV	-118.9 °C
310mV	-89.3 °C
360mV	-59.6 °C
410mV	-29.0 °C
460mV	0.3 °C
510mV	29.3 °C
560mV	59.0 °C
610mV	88.7 °C

The voltage difference between the Vo2 and Vo1 references define the resolution and temperature range.

Figure 21:
Temperature Conversion Resolution and Range

Vo2 - Vo1	Resolution	Range
310mV (default)	0.18 °C	183.9 °C
50mV	0.029 °C	29.7 °C
100mV	0.058 °C	59.3 °C
150mV	0.086 °C	88.0 °C
200mV	0.116 °C	118.6 °C
250mV	0.145 °C	148.3 °C
260mV	0.151 °C	154.2 °C
300mV	0.174 °C	177.9 °C
350mV	0.203 °C	207.6 °C
360mV	0.209 °C	213.5 °C
400mV	0.232 °C	237.2 °C

Example:

Vo1 = 310mV, Vo2 = 410mV -> A/D conversion temperature range = -29.3°C ~ 30.0 °C.

Temperature resolution = 0.058 °C.

The converted voltage can be calculated from the following equation:

$$V_{\text{SENS}} = \text{code} \cdot \frac{V_{o2} - V_{o1}}{1024} + V_{o1}$$

Temperature Conversion

The calibration data does not have to be included in the temperature conversion equation. The temperature value calculation is dependent on the selected voltage references (See "Analog to Digital Conversion" on page 18.):

$$T \cdot (^\circ\text{C}) = \text{code} \cdot \text{Resolution} - \text{Low} \cdot \text{temp} \cdot \text{limit}$$

By default (factory setting), the voltage references are set: $V_{o1} = 0\text{V}$, $V_{o2} = 310\text{mV}$. This yields a theoretical temperature conversion range of $-89.3^\circ\text{C} \sim +94.6^\circ\text{C}$. The temperature conversion equation for this setting is:

$$T \cdot (^\circ\text{C}) = \text{code} \cdot 0.18^\circ\text{C} - 89.3^\circ\text{C}$$

$$\text{LSB} = 0.18^\circ\text{C}$$

$$\text{Offset} = (-89.3)^\circ\text{C}$$

When the reference voltages are set to some other value, the following equation needs to be used for temperature conversion:

$$T \cdot (^\circ\text{C}) = \frac{V_{o2}[\text{mV}] \cdot (\text{code} + 1024) - \text{code} \cdot V_{o1}[\text{mV}]}{1024 \cdot 1.686} - 273.15$$

The V_{o1} and V_{o2} in the above equation have to be in mV.

Battery Voltage Conversion

The battery voltage conversion is dependent on the initial battery voltage (1.5V or 3V) and on the selected voltage references (See "Analog to Digital Conversion" on page 18.). The conversion equations with factory selected voltage references ($V_{o1} = 0\text{V}$, $V_{o2} = 310\text{mV}$) are:

For 1.5V battery, the equation is:

- $V = \text{code} \cdot 0.85\text{mV} + 873\text{mV}$
- $\text{LSB} = 0.85\text{mV}$
- $\text{Offset} = 873\text{mV}$

For 3V battery:

- $V = \text{code} \cdot 1.65\text{mV} + 1.69\text{V}$
- $\text{LSB} = 1.65\text{mV}$
- $\text{Offset} = 1.69\text{V}$

Commands

Some commands can be password protected by 3 different passwords: System password (S), Application password (A) or Measurement password (M).

Figure 22:
EPC Gen2 and Cool-Log™ Command Overview

#	Command	Command Code	Allowed in Modes					Mode Change	Security Level	Definition
			LOGGING	SERIAL	READY	ACTIVE	STAND-BY			
01	QueryRep	0b00	-	√	√	√	-	No	/	EPC Gen2 anticollision round command
02	ACK	0b01	-	√	√	√	-	Yes	/	EPC Gen2 anticollision round command
03	Query	0b1000	-	√	√	√	-	No	/	EPC Gen2 anticollision round command
04	QueryAdjust	0b1001	-	√	√	√	-	No	/	EPC Gen2 anticollision round command
05	Select	0b1010	-	√	√	√	-	No	/	EPC Gen2 anticollision round command
06	NAK	0xC0	-	√	√	√	-	No	/	EPC Gen2 anticollision round command
07	Req_RN	0xC1	-	√	√	√	-	No	/	Request for a new 16-bit random number
08	Read	0xC2	-	√	√	√	-	No	A or M	Reads the selected block in the specified memory bank
09	Write	0xC3	-	√	√	√	-	No	A or M	Writes the selected block in the specified memory bank
10	Kill	0xC4	-	√	√	√	-	No	/	Kills the transponder – no RFID access is possible after this command (SPI remains active)

#	Command	Command Code	Allowed in Modes					Mode Change	Security Level	Definition
			LOGGING	SERIAL	READY	ACTIVE	STAND-BY			
11	Lock	0xC5	-	√	√	√	-	No	/	Locks the selected memory banks
12	Access	0xC6	-	√	√	√	-	No	/	Puts the transponder to the secured state
13	BlockWrite	0xC7	-	√	√	√	-	No	A or M	Writes the selected block in the specified memory bank
14	BlockErase	0xC8	-	√	√	√	-	No	A or M	Erases the selected block in the specified memory bank
<p>Note: The cool-Log commands are defined as EPC custom commands. All custom commands have a 16-bit command code, where the 1st command code is defined as 0xE0, the second command code is in the table below.</p>										
15	Set Password	0xA0	-	√	√	√	-	No	S, M or A	Sets the passwords to EEPROM
16	Set Log Mode	0xA1	-	√	√	-	-	No	S	Sets logging mode
17	Set Log Limits	0xA2	-	√	√	-	-	No	S	Sets the measurement limits for limits logging mode
18	Get measurement setup	0xA3	-	√	√	√	-	No	S	Reads 4 system blocks - Start time, Log limits, Log mode, and Delay time + application area size
19	Set SFE parameters	0xA4	-	√	√	-	-	No	S	Sets parameter for the External sensor front end
20	Set Calibration Data	0xA5	-	√	√	-	-	No	S	Sets the calibration data for the temperature sensor and timer
21	End Log	0xA6	-	√	-	√	-	Yes	S	Stops the log procedure and returns the chip to Standby mode

#	Command	Command Code	Allowed in Modes					Mode Change	Security Level	Definition
			LOGGING	SERIAL	READY	ACTIVE	STAND-BY			
22	Start Log	0xA7	-	√	√	-	-	Yes	S	Starts the timer and the selected log procedure
23	Get Log State	0xA8	-	√	√	√	-	No	S	Gets the log state of the chip
24	Get calibration data	0xA9	-	√	√	√	-	No	S	Reads the internal and external calibration data
25	Get Battery level	0xAA	-	√	√	√	-	No	/	Measures the battery voltage
26	Set Shelf Life	0xAB	-	√	√	-	-	No	/	Set the shelf life parameters
27	Initialize	0xAC	-	√	√	-	-	No	S	Initializes the chip and sets the application area size and the logging delay
28	Get Sensor Value	0xAD	-	√	√	√	-	No	/	Measures the specified sensor – temperature, ext. sensor1 or ext. sensor 2
29	Open Area	0xAE	-	√	√	√	-	No	/	Opens access to the specified EEPROM area
30	Access FIFO	0xAF	-	√	√	√	-	No	/	Reads or writes the 8-byte FIFO register (for fast SPI to RFID data transfer)

Supported EPC Gen2 Commands

QueryREP - #01

The QUERRY_REP command instructs tags to decrement their slot counter and is specified for one out of 4 sessions. If the slot counter becomes 0 after decrementing, the tag will backscatter its RN16.

ACK - #02

When a tag receives the ACK command in the Reply state, it will transition to the Acknowledged state and backscatter the EPC. The EPC can be truncated if this has been requested by the reader in the SELECT command. The ACK command can also be processed in the Open or Secured states, but in this case no state transition will occur.

Query - #03

The QUERY command initiates and specifies an inventory round. It sets the TX and RX data rates. It also defines the number of slots used for the inventory round. When the tag receives the QUERY command, it will calculate a random RN16 if it has a matching Sel and Target. The tag will backscatter the RN16 value in case the slot counter is loaded with 0.

QueryAdjust - #04

The QUERY_ADJUST command increments or decrements the Q number (number of slots) for the current inventory round.

Select - #05

The SELECT command selects a tag population that will participate in the inventory round, based on user-defined criteria. The tag can receive any number of successive SELECT commands.

NAK - #06

When a tag receives the NAK command, it will transition to the Arbitrate state, unless it is in the Kill or Ready states. The tag will not send any reply to the NAK command.

Req_RN - #07

The REQ_RN command will instruct the tag to backscatter a new RN16. When a tag in the Acknowledged state receives a correct REQ_RN command, it will transition to the Open or Secured state. When the tag is in the Open or Secured state, it will backscatter a new RN16 and no state transition will occur.

Read - #08

The Read command instructs the tag to read and backscatter a part or all of the Reserved, EPC, TID or User memory.

Write - #09

The WRITE command allows the interrogator to write a word (16 bits) in the tags Reserved, EPC, TID or User memory. Prior to sending the Write command, the interrogator has to send the REQ_RN command in order to receive a new RN16 that will be used for cover-coding the data by EXOR-ing it with the RN16. In case the data writing has been successful, the tag will backscatter the response within 20ms after receiving the command.

Kill - #10

The KILL command is used to permanently disable a tag. When the tag receives the correct multi-step Kill procedure, it will transition to the Killed state and will not send any response thereafter.

Lock - #11

The LOCK command instructs the tag to lock the specified block of the EEPROM memory. The Kill and Access passwords can be Read/Write locked, while the EPC, TID and User block can only be Write locked. The command will only be executed in the Secured state.

Access - #12

The ACCESS command with a correct password and correct multi-step procedure instructs the tag to transition from the Open to the Secured state. When the tag has successfully received the multi-step access procedure, it will backscatter its handle.

BlockWrite - #13

The BLOCK_WRITE command writes a single word of data (16 bits) to the specified memory address. It provides faster data writing than the WRITE command as it does not need a new RN16 for every word of data that has to be written. In case the data writing has been successful, the tag will backscatter the response within 20ms after receiving the command.

BlockErase - #14

The BLOCK_ERASE command erases a single word in the specified memory bank. In case the erase has been successful, the tag will backscatter the response within 20ms after receiving the command.

Cool-Log Custom Commands

Set Password - #15

The SET PASSWORD command sets the password for the specified memory area. This is the System area, Application area and Measurement area. The System area is in the Reserved memory bank. The Application and Measurement areas are in the User memory bank. In case the command has executed successfully, the tag will backscatter the response within 20ms after receiving the command.

Set Log Mode - #16

The SET LOG MODE command sets various parameters for the logging procedure. In case the command has executed successfully, the tag will backscatter the response within 20ms after receiving the command.

Set Log Limits - #17

The SET LOG LIMITS command write the 4 limits that are going to be used for logging measurement data. The limits are: Extreme upper limit, Upper limit, Lower limit and Extreme lower limit. In case the command has executed successfully, the tag will backscatter the response within 20ms after receiving the command.

Get Measurement Setup - #18

The GET MEASUREMENT SETUP command reads 4 system blocks - Start time, Log limits, Log mode and Delay time.

Set SFE Parameters - #19

The SET SFE PARAMETERS command sets the parameters for the External sensor front end.

Set Calibration Data - #20

The SET CALIBRATION DATA command sets the calibration values for the internal temperature sensor.

WARNING – the factory preset calibration data can be overwritten. It is advised to read the calibration data, change only the required bits and write back with the SET CALIBRATION DATA command.

End Log - #21

The END LOG command stops the logging procedure and returns the chip to passive mode. It also stops the timer.

Start Log - #22

The START LOG command starts the logging procedure and sets the Start time in UTC format. In logging state the chips automatically performs the measurements and data logging in the specified time intervals. Supported is also a delayed start, which means that the chip will start with the logging procedure with a specified delay after it receives the START LOG command. This command also starts the Interrupt mode of operation where the measurements and data-logging are driven from external events.

Get Log State - #23

The GET LOG STATE command gets the log state of following parameters: measurement status and out of limits counter. This gives the ability to quickly check the state of the package without the need to read the whole temperature data log.

Get Calibration Data - #24

The GET CALIBRATION DATA command reads the calibration data for the internal and external sensors.

Get Battery Level - #25

The GET BATTERY LEVEL command measures and reads the voltage level of the battery.

Set Shelf Life - #26

The SET SHELF LIFE command writes the shelf life algorithm parameters and enables the dynamic shelf life calculation.

Initialize - #27

The INITIALIZE command sets the size of the application data area and sets the delay time. The command clears the measurement status and limits counter blocks.

Get Sensor Value - #28

The GET SENSOR VALUE command measures and backscatters the value of the specified sensor – internal, external 1 or external 2.

Open Area - #29

The OPEN AREA command opens the specified area of the memory (System, Application, and Measurement). The password is stored in a RAM location and compared with the password in EEPROM. When the tag leaves the RF field, this RAM location is cleared.

Access FIFO - #30

The ACCESS FIFO command can read or write the 8-byte FIFO. The FIFO can also be accessed from the SPI so this command can be used for fast data transfer between a microcontroller connected to the SPI and an RFID reader.

Custom Command Description

Upon receiving a valid command, the tag always transmits a reply. If the command can not be executed, the tag replies with the following error message:

Reply Structure (error):

SOF	Header	Error code	Handle	CRC	EOF
Pilot tone + preamble	1 bit [1]	8 bits	16 bits	16 bits	Dummy bit [1]

The error codes are defined as:

Error Code	Error Name	Error Description	Condition
00000000	Other error	For error s that are not covered by the other specified error codes	
00000011	Memory overrun	The specified memory location does not exist or the EPC length field is not supported by the tag	The EBV address is outside the physical address of the EEPROM or outside the specified memory bank.
00000100	Memory locked	The specified memory location is locked and/or permalocked and can not be read or written.	The lock bit for the specified memory bank or password is set.
00001011	Insufficient power	The tag has insufficient power to perform the memory write operation.	This error code can only be set in fully passive mode when the supply voltage is to low.
10100000	Incorrect password	The password is incorrect – tag is not open.	The IDS custom password protection is active.
10100010	Battery measurement error	The battery measurement can not be started.	The tag is fully passive and there is no battery attached.
10100011	Command not allowed	Command is not allowed in active state.	Custom commands that can modify logging and calibration parameters are not allowed when the tag is in active state (RTC running).
10100110	EEPROM busy error	The memory can not be accessed as the measurement unit or SPI is accessing the EEPROM.	This error is reported when the EEPROM is used by the SPI or measurement unit.

Set Password

The SET PASSWORD command writes a 32 - bit password to the EEPROM. The password protection for the specified area is automatically enabled if the password is any other value except 0.

Command Structure:

SOF	Custom	Command Code	Password Level	Password	Handle	CRC
Frame-sync	0xE0	0xA0	8 bits	32 bits	16 bits	16 bits

Successful Reply Structure:

SOF	Header	Handle	CRC	EOF
Pilot tone + preamble	1 bit [0]	16 bits	16 bits	Dummy bit [1]

The "Password Level" bits are:

Password Level Bits	b1	b0	Passw. level
Bits b7 - b2 are X	0	0	Not allowed
	0	1	System
	1	0	Application
	1	1	Measurement

When the System area is open for writing, the Set password can change the passwords for all 3 password levels. When the System area is write-protected, the Set password command can not change the System password, but it can change the Application password, if the Application area is open, and the Measurement password when the Measurement area is open.

Set Log Mode

The SET LOG MODE command sets the logging form, storage rule, enables sensors that are used in the logging process and sets the logging interval (in 1 second steps).

Command Structure:

SOF	Custom	Command Code	Log Mode	Handle	CRC
Frame - sync	0xE0	0xA1	24 bits	16 bits	16 bits

In case the operation is successful, the following reply will be sent:

Successful Reply Structure:

SOF	Header	Handle	CRC	EOF
Pilot tone + preamble	1 bit [0]	16 bits	16 bits	Dummy bit [1]

The “Log mode” field is composed as:

Bit Number	23 ... 21	20	19	18	17	16	15 ... 1	0
Function	Logging form [2:0]	Storage rule	Ext.1 sensor enable	Ext.2 sensor enable	Temp. sensor enable	Battery check enable	Log interval [14:0]	RFU

Set Log Limits

The SET LOG LIMITS command writes the 4 limits that are used in the logging process. All 4 limits are 10 bits long.

Command Structure:

SOF	Custom	Command Code	Log Limits	Handle	CRC
Frame - sync	0xE0	0xA2	40 bits	16 bits	16 bits

Successful Reply Structure:

SOF	Header	Handle	CRC	EOF
Pilot tone + preamble	1 bit [0]	16 bits	16 bits	Dummy bit [1]

The “Log Limits” field is composed as:

Bit Number	39 ... 30	29 ... 20	19 ... 10	9 ... 0
Function	Extreme lower limit	Lower limit	Upper limit	Extreme upper limit

Get Measurement Setup

The GET MEASUREMENT SETUP command will read the current system setup of the chip.

Command Structure:

SOF	Custom	Command Code	Handle	CRC
Frame - sync	0xE0	0xA3	16 bits	16 bits

Successful Reply Structure:

SOF	Header	Start Time	Log Limits	Log Mode	Log Interval	Delay Time	Application Data	Handle	CRC	EOF
Pilot tone + preamble	1 bit [0]	32 bits	40 bits	8 bits	16 bits	16 bits	16 bits	16 bits	16 bits	Dummy bit [1]

The “Log Limits” field is composed as:

Bit Number	39 ... 30	29 ... 20	19 ... 10	9 ... 0
Function	Extreme lower limit	Lower limit	Upper limit	Extreme upper limit

The “Log Mode” field is composed as:

Bit Number	7 ... 5	4	3	2
Function	Logging form [2:0]	Storage rule	Ext.1 sensor enable	Ext.2 sensor enable

The “Log Interval” field is composed as:

Bit Number	15 ... 1	0
Function	Log interval [14:0]	RFU

The “Delay Time” field is composed as:

Bit Number	15 ... 4	3 ... 2	1	0
Function	Delay time [11:0]	RFU [1:0]	Delay mode [0 – timer, 1 – external switch]	IRQ+timer enable

The “Application Data” field is composed as:

Bit Number	15 ... 7	6 ... 3	2 ... 0
Function	Number of words for application data [8:0]	RFU [3:0]	Broken word pointer [2:0]

Set SFE Parameters

The SET SFE PARAMETERS command writes the Sensor Front End parameters to the memory. Those parameters include the range preset values for the external sensor inputs, external sensor types and the also the sensor that will be used for limits comparison.

Command Structure:

SOF	Custom	Command Code	SFE Parameters	Handle	CRC
Frame - sync	0xE0	0xA4	16 bits	16 bits	16 bits

Successful Reply Structure:

SOF	Header	Handle	CRC	EOF
Pilot tone + preamble	1 bit [0]	16 bits	16 bits	Dummy bit [1]

The "SFE Parameters" field is composed as:

Bit Number	15 ... 11	10 ... 6	5 ... 4	3	2	1 ... 0
Function	Rang [4:0]	Seti [4:0]	EXT1 [1:0]	EXT2	Autorange disable	Verify sensor ID [1:0]

Set Calibration Data

The SET CALIBRATION DATA write to the calibration block in the EEPROM memory. The calibration data is preset during manufacturing, but can also be changed in the application if needed. The SET CALIBRATION DATA will write only to the EEPROM, but it will not update the calibration values in the calibration registers. The calibration registers are automatically updated with each START LOG command.

Command Structure:

SOF	Custom	Command Code	Calibration Data	Handle	CRC
Frame - sync	0xE0	0xA5	56 bits	16 bits	16 bits

Successful Reply Structure:

SOF	Header	Handle	CRC	EOF
Pilot tone + preamble	1 bit [0]	16 bits	16 bits	Dummy bit [1]

Note: The "Calibration data" field is composed of 7 bytes (See "Calibration Bits" on page 63.).

End Log

The END LOG command stops the logging procedure and turns off the real time clock. It also clears the Active flag that is store in the “System status” field in the EEPROM.

Command Structure:

SOF	Custom	Command Code	Handle	CRC
Frame - sync	0xE0	0xA6	16 bits	16 bits

Successful Reply Structure:

SOF	Header	Handle	CRC	EOF
Pilot tone + preamble	1 bit [0]	16 bits	16 bits	Dummy bit [1]

Start Log

The START LOG command starts the logging process. It refreshes the data in the calibration registers, enables the RTC, writes the Start time and sets the Active bit in the “System status” field in the EEPROM.

Command Structure:

SOF	Custom	Command Code	Start Time	Handle	CRC
Frame - sync	0xE0	0xA7	32 bits	16 bits	16 bits

Successful Reply Structure:

SOF	Header	Handle	CRC	EOF
Pilot tone + preamble	1 bit [0]	16 bits	16 bits	Dummy bit [1]

The “Start Time” field is composed as:

Bit Number	31 ... 26	25 ... 22	21 ... 17	16 ... 12	11 ... 6	5 ... 0
Function	Year [5:0]	Month [3:0]	Day [4:0]	Hour [4:0]	Minute [5:0]	Second [5:0]

Get Log State

The GET LOG STATE command reads the status of the logging process. The command can be used to quickly determine the current state of the product, together with the Shelf life and the Limit counter.

Command Structure:

SOF	Custom	Command Code	Handle	CRC
Frame - sync	0xE0	0xA8	16 bits	16 bits

Successful Reply Structure:

SOF	Header	Limit Counter	System Status	SL-block 0&1	Current Shelf Life	Status Flags	Handle	CRC	EOF
Pilot tone + preamble	1 bit [0]	32 bits	32 bits	64 bits (see Note)	24 bits (see Note)	8 bits	16 bits	16 bits	Dummy bit [1]

OPTIONAL - only when Shelf Life flag is set in the EEPROM.

The "Limit Counter" field is composed as:

Bit Number	31 ... 24	23 ... 16	15 ... 8	7 ... 0
Function	Extreme lower [7:0]	Lower [7:0]	Upper [7:0]	Extreme upper [7:0]

The "System Status" field is composed as:

Bit Number	31 ... 22	21 ... 16	15 ... 1	0
Function	Measurement address pointer [9:0]	Number of memory replacements [5:0]	Number of measurements [14:0]	Active

The "Status Flags" field is composed as:

Bit Number	7	6	5	4	3	2	1	0
Function	Active (logging process)	Measurement area full	Measurement overwritten	AD error	Low battery	Shelf life low error	Shelf life high error	Shelf Life expired

Get Calibration Data

The GET CALIBRATION DATA command reads the calibration data field and the SFE parameters field.

Command Structure:

SOF	Custom	Command Code	Handle	CRC
Frame - sync	0xE0	0xA9	16 bits	16 bits

Successful Reply Structure:

SOF	Header	Calibration Data & SFE Parameters	Handle	CRC	EOF
Pilot tone + preamble	1 bit [0]	72 bits	16 bits	16 bits	Dummy bit [1]

The content of the Calibration data field and the SFE parameters field is displayed in the Memory map in ["SPI Interface" on page 45](#).

Get Battery Level

The GET BATTERY LEVEL command starts the AD conversion on the battery voltage and returns the voltage level with the battery type (1.5V or 3V).

Command Structure:

SOF	Custom	Command Code	Battery retrigger	Handle	CRC
Frame - sync	0xE0	0xAA	8 bits	16 bits	16 bits

Successful Reply Structure:

SOF	Header	A/D Error	Battery Type	Zeros	Battery Level	Handle	CRC	EOF
Pilot tone + preamble	1 bit [0]	1 bit - error [1]	1 bit - [0 = 1.5V, 1 = 3V]	4 bits [0000]	10 bits	16 bits	16 bits	Dummy bit [1]

The application can also request the battery type re-check if the Battery retrigger field has the value "0000001", otherwise the Battery retrigger field needs to have the value "0000000".

Set Shelf Life

The SET SHELF LIFE command programs parameters for the dynamic shelf life algorithm.

Command Structure:

SOF	Custom	Command Code	SL Block 0	SL Block 1	Handle	CRC
Frame - sync	0xE0	0xAB	32 bits	32 bits	16 bits	16 bits

Successful Reply Structure:

SOF	Header	Handle	CRC	EOF
Pilot tone + preamble	1 bit [0]	16 bits	16 bits	Dummy bit [1]

The "SL Block 0" field is composed as:

Bit Number	31 ... 24	23 ... 16	15 ... 8	7 ... 0
Function	Tmax [7:0]	Tmin [7:0]	Tstd [7:0]	Ea [7:0]

The "SL Block 1" field is composed as:

Bit Number	31 ... 16	15 ... 6	5 ... 4	3	2	1 ... 0
Function	SLinit [15:0]	Tinit [9:0]	Shelf life sensor ID [1:0]	Enable negative shelf life	Shelf life algorithm enable	RFU [1:0]

Initialize

The INITIALIZE command clears the System status field, the Limit counters and sets the Delay time field and the Application data field. The Initialize command is needed before the START LOG command as it will clear the pointers and counters. If the application needs to run the logging process from the previous point on, the Initialize command can be left out.

Command Structure:

SOF	Custom	Command Code	Delay Time	Application time	Handle	CRC
Frame - sync	0xE0	0xAC	16 bits	16 bits	16 bits	16 bits

Successful Reply Structure:

SOF	Header	Handle	CRC	EOF
Pilot tone + preamble	1 bit [0]	16 bits	16 bits	Dummy bit [1]

The “Delay Time” field is composed as:

Bit Number	15 ... 4	3 ... 2	1	0
Function	Delay time [11:0]	RFU [1:0]	Delay mode [0 – timer, 1 – external switch]	IRQ+timer enable

The “Application Data” field is composed as:

Bit Number	15 ... 7	6 ... 3	2 ... 0
Function	Number of words for application data [8:0]	RFU [3:0]	Broken word pointer [2:0]

Get Sensor Value

The GET SENSOR VALUE command starts the AD conversion on the specified sensor and returns the value.

Command Structure:

SOF	Custom	Command Code	Sensor Type	Handle	CRC
Frame - sync	0xE0	0xAD	8 bits	16 bits	16 bits

Successful Reply Structure:

SOF	Header	A/D Error	Range/Limit	Sensor Value	Handle	CRC	EOF
Pilot tone + preamble	1 bit [0]	1 bit - error [1]	5 bits ^{(1), (2)}	10 bits	16 bits	16 bits	Dummy bit [1]

Note(s) and/or Footnote(s):

1. RANGE - for external sensors
2. LIMIT CURRENT - for self heating compensation.

The “Sensor Type” field is composed as:

Bit Number	7 ... 2	1 ... 0
Function	RFU [5:0] – all 0's	Sensor type: <ul style="list-style-type: none"> • 00 – Temperature sensor • 01 – External sensor 1 • 10 – External sensor 2 • 11 – Battery voltage

Open Area

The OPEN AREA command opens the specified area (System, Application, and Measurement) that is protected by a password.

Command Structure:

SOF	Custom	Command Code	Password Level	Password	Handle	CRC
Frame - sync	0xE0	0xAE	8 bits	32 bits	16 bits	16 bits

Successful Reply Structure:

SOF	Header	Handle	CRC	EOF
Pilot tone + preamble	1 bit [0]	16 bits	16 bits	Dummy bit [1]

The "Password Level" field is composed as:

Password Level Bits	b1	b0	Passw. level
Bits b7 - b2 are X	0	0	Not allowed
	0	1	System
	1	0	Application
	1	1	Measurement

Access FIFO

The ACCESS FIFO command can read and write data from the FIFO and can also read the FIFO status register.

Command Structure:

SOF	Custom	Command Code	Sub-command	Payload	Handle	CRC
Frame - sync	0xE0	0xAF	8 bits	0 ~ 8 bytes	16 bits	16 bits

Successful Reply Structure:

SOF	Header	Payload	Handle	CRC	EOF
Pilot tone + preamble	1 bit [0]	0 ~ 8 bytes (data from FIFO or FIFO status register)	16 bits	16 bits	Dummy bit [1]

Possible Subcommand codes are defined as:

Subcommand bits			Function	Comment
7	6	5		
1	0	0	Read data from FIFO	The bits 3-0 specify the number of bytes that will be read from FIFO
1	0	1	Write data to FIFO	The bits 3-0 specify the number of bytes that will be written to FIFO
1	1	0	Read status register	

The FIFO status register is defined as:

Bit #	Function
7	FIFO busy
6	Data ready
5	No data
4	0 – data from SPI, 1 – data from RFID
3	Number of valid bytes in FIFO register (0000 – FIFO empty, 0001 – 1 byte, 1000 – 8 bytes)
2	
1	
0	

Access FIFO command example:

- Frame sync + E0 AF A5 11 22 33 44 55 + Handle + CRC
- This example command will write 5 bytes to the FIFO.

Logging Formats

The logging format is selected with the SET LOG MODE command in the “Logging Mode[2:0]” field.

Figure 23:
Supported Logging Formats

Logging Mode [2:0]			Logging Form	Description
Bit 2	Bit 1	Bit 0		
0	0	0	Dense	All values are stored to the measurement area. No additional time information is stored to the measurement area.
0	0	1	All values out of limits	All values that are out of the specified limits are stored to the measurement area. Limits comparison is done on the selected sensor (“Verify sensor ID [1:0]”). The measurement number is stored, additional to the sensor value.
0	1	0	RFU	Reserved for future use – this setting is not allowed
0	1	1	Limits crossing	Only the crossing point of each limit boundary is stored. Limits comparison is done on the selected sensor (“Verify sensor ID [1:0]”). The measurement number is stored, additional to the sensor value.
1	0	0	RFU	Reserved for future use – this setting is not allowed
1	0	1	IRQ, EXT1	Interrupt triggered on the EXT1 external sensor input
1	1	0	IRQ, EXT2	Interrupt triggered on the EXT2 external sensor input
1	1	1	IRQ, EXT1, EXT2	Interrupt triggered on the EXT1 and EXT2 external sensor input

Dense Logging Form

The dense logging form provides maximum usage of the non-volatile memory space. 8 sensor values are stored into 5 words of memory when only the internal temperature sensor is used:

Figure 24:
Dense Form - Only Internal Temperature Sensor

Block #	Bits															
	15	14	13	12	11	10	9	8	7	6	5	4	3	2	1	0
0x00	Temp. 1								Temp. 2							
0x01	Temp. 2				Temp. 3								Temp. 4			
0x02	Temp. 4								Temp. 5							
0x03	Temp. 5		Temp. 6								Temp. 7					
0x04	Temp. 7				Temp. 8											

In case external sensors are used for logging, the chip will use the following storage format:

Figure 25:
Dense Form with External Sensors

	Bits															
Block #	15	14	13	12	11	10	9	8	7	6	5	4	3	2	1	0
0x00	1	Range 5 bits					External sensor 1 - 10 bits									
0x01	1	Range 5 bits					External sensor 2 - 10 bits									
0x02	Bat. meas. 6 bits					Temperature meas. - 10 bits										

In the dense logging form, no time information is stored in the measurement area of the EEPROM in order to maximize the number of stored sensor values. The real time of a particular measurement can be calculated by using the Start time and Log interval.

Out-of-Limits Logging Form

This logging form uses the limits that are set by the user. The limits can be set with the SET LOG LIMITS command. The storage data format is the same for the "All values out-of-limits" form and the "Limits crossing" form.

Figure 26:
Limits Mode with Internal Sensor Only

	Bits															
Block #	15	14	13	12	11	10	9	8	7	6	5	4	3	2	1	0
0x00	Battery voltage						Temperature									
0x01	Measurement #															

Figure 27:
Limits Mode with External Sensors

	Bits															
Block #	15	14	13	12	11	10	9	8	7	6	5	4	3	2	1	0
0x00	1	Range 5 bits					External sensor 1 - 10 bits									
0x01	1	Range 5 bits					External sensor 2 - 10 bits									
0x02	Bat. meas. 6 bits					Temperature meas. - 10 bits										
0x03	Measurement #															

Interrupt Logging Form

This logging form is used when the interrupts from external sensors are enabled. In this case, the real time clock is stored together with the sensor values.

Figure 28:
Interrupt Mode

Block #	Bits															
	15	14	13	12	11	10	9	8	7	6	5	4	3	2	1	0
0x00	1	Range 5 bits					External sensor 1 - 10 bits									
0x01	1	Range 5 bits					External sensor 2 - 10 bits									
0x02	Bat. meas. 6 bits					Temperature meas. - 10 bits										
0x03	Real time clock - Higher 16 bits															
0x04	Real time clock - Lower 16 bits															

Note(s) and/or Footnote(s):

1. The interrupt source can either be the external sensor 1, external sensor 2 or both external sensors. The limits are ignored in the interrupt mode.

Storage Capacity

The storage capacity is the number of measurement points that can be stored to the EEPROM. It is dependent on the selected logging form.

Figure 29:
Storage Capacity:

Selected Sensors	Dense	Limits (both modes)	Event Triggered
Only temperature	841	263	175
Temperature + battery	526	263	175
1 External	526	263	175
Temperature + External	263	175	131
Temperature + External + Battery	263	175	131
2 External	263	175	131
Temperature + 2 external	175	131	105
All 4 sensors	175	131	105

Storage Rule

The Storage rule defines how the device handles a completely full Measurement area. The device has 2 storage rules – normal or rolling.

Normal storage rule

In this storage rule, the logging of new data is stopped when the memory is completely full. When this happens, the bit 6 in the Status Flags (Measurement area full) is set to 1 and no new data is stored to the EEPROM. However, the timer is still active and the Number of measurements counter will still be incremented.

Rolling storage rule

In this mode, the device will overwrite the old data with new data once the measurement area is completely full. When this happens, the bit 6 (Measurement area full) and bit 5 (Measurement overwritten) in the Status Flags are set to 1 and the Number of memory replacements counter is incremented. The new measurement is stored to the beginning of the Measurement area.

When the dense logging mode with temperature sensor is used with the rolling storage mode and the memory is overwritten, the new data is stored from the beginning of the Measurement area starting with a fresh 5-block 8-measurements super-block. It does not matter if the last super-block at the end of the memory was not completed due to the end of the memory.

When more sensors are enabled or the limits mode is used, it can happen that the last measurement at the end of the memory can not be written, because there is not enough space. An example for this is if all 4 sensors are enabled in dense logging mode. In this case, 1 measurement is 3 blocks long. If it happens that there are only 2 blocks free in the memory, the measurement will be written to the beginning of the Measurement area, so the last 2 blocks are not used.

When the Number of memory replacement counter reaches its maximum value, the logging is stopped and no new data is written to the EEPROM. However, the timer will still be active and the Number of measurements counter will still be incremented.

SPI Interface

Full and unlimited EEPROM access is possible through the SPI interface. The primary function of the SPI interface is production calibration and UID programming, but it can also be used in application, for the data transmission between the interrogator and a microcontroller attached to the SPI interface. The chip has a basic arbitration implemented that controls the EEPROM access from the RFID interface, the automatic data logger and the SPI interface. The RFID interface has the highest priority, second is the automatic data logger, and last is the SPI interface.

The first 2 bits in the frame are the MODE bits, which define the SPI operation (00 – Write memory, 01 – Read memory, 10 – Test, 11 – Direct command). The EEPROM address is an 11-bit address that point to the physical locations in the EEPROM. The write command can be executed on a single byte, or any number of successive bytes on a single page (up to 16 bytes). The minimum number of bytes in the Page write operation is 2. The Read operation is a continuous operation, so any number of bytes can be read with a single frame. The address is the starting address and is automatically incremented in the chip.

The Test MODE is reserved for production testing and cannot be used in application.

The maximum SCLK frequency is 10MHz at 3V battery supply (dual cell). With a 1.5V battery supply the maximum frequency is 2MHz.

Figure 30:
SPI Communication Modes

	MODE		EEPROM Address / Command Code				Data Byte
	A15	A14	A13	A12	A11	A10...A0	D7...D0
Write Mode	0	0	0	0	0	Physical EEPROM address	DI7 ... DI0
Page Write Mode	0	0	0	0	1	Physical EEPROM address	DI7 ... DI0
Read Mode	0	1	0	0	0	Physical EEPROM address	DO7...DO0
Test Mode	RESERVED for PRODUCTION						
Command Mode	1	1	C5...C0				

...16 data bytes

...Continuous read (n*8 bits)

Figure 31:
SPI Timings

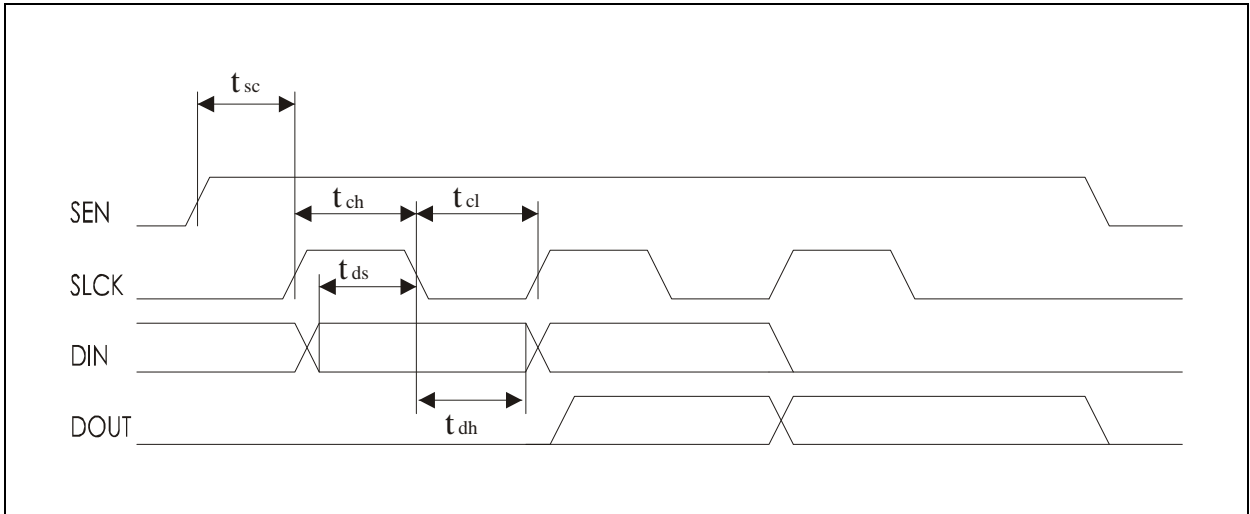

Figure 32:
SPI Timing for 3V Supply Voltage

Symbol	Min	Max	Description
t_{sc}	150us	-	SEN to first SCLK rising edge setup time
t_{ch}	100ns	-	SCLK high period
t_{cl}	100ns	-	SCLK low period
t_{ds}	50ns	-	Data setup time
t_{dh}	50ns	-	Data hold time

Figure 33:
SPI Timing for 1.5V Supply Voltage

Symbol	Min	Max	Description
t_{sc}	150us	-	SEN to first SCLK rising edge setup time
t_{ch}	500ns	-	SCLK high period
t_{cl}	500ns	-	SCLK low period
t_{ds}	50ns	-	Data setup time
t_{dh}	50ns	-	Data hold time

Figure 34:
SPI Write Mode

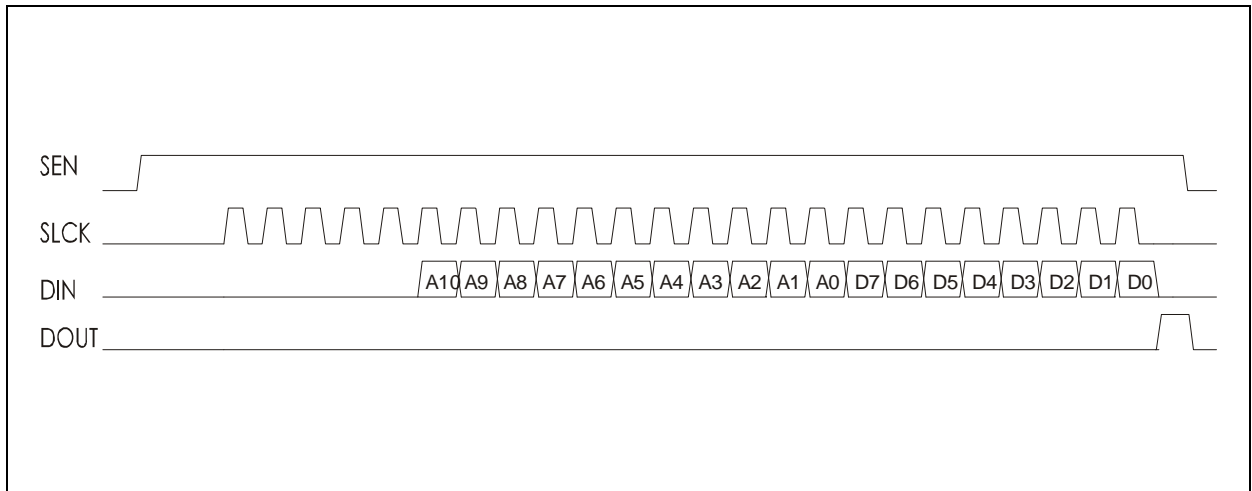

Figure 35:
SPI Read Mode

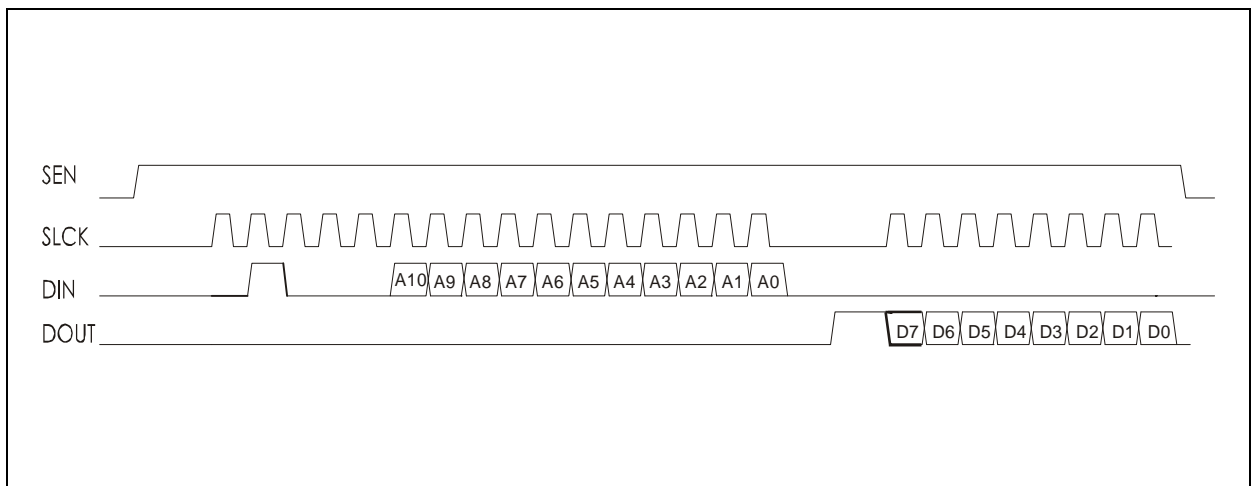

Figure 36:
SPI Command Mode - Start Log and Stop Log, Reset command

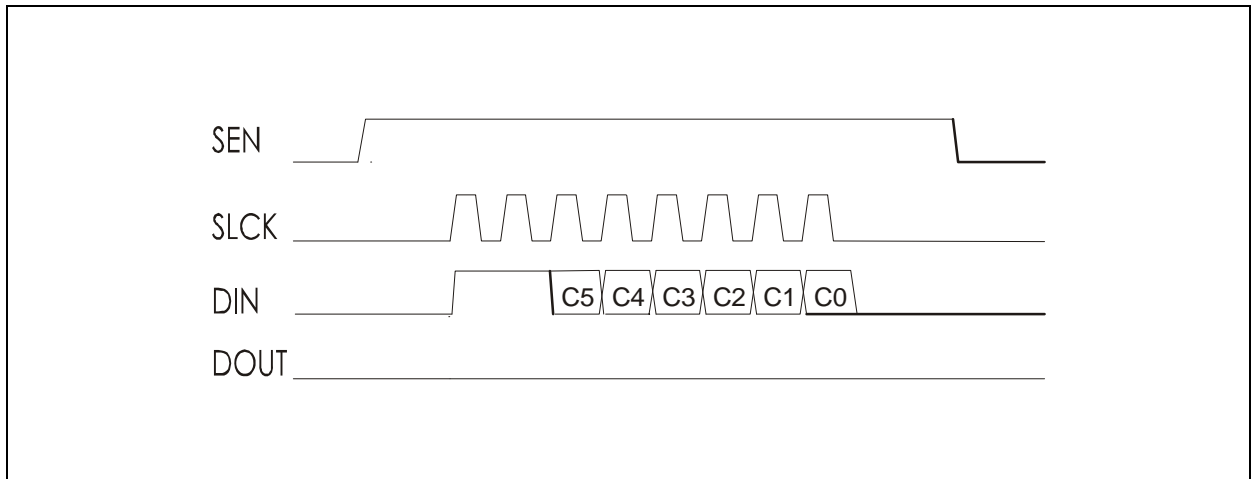

Figure 37:
SPI Command Mode – Get Temperature, Get Ext. Sensor, Get Battery, Read Fifo, Read Remaining Shelf Life

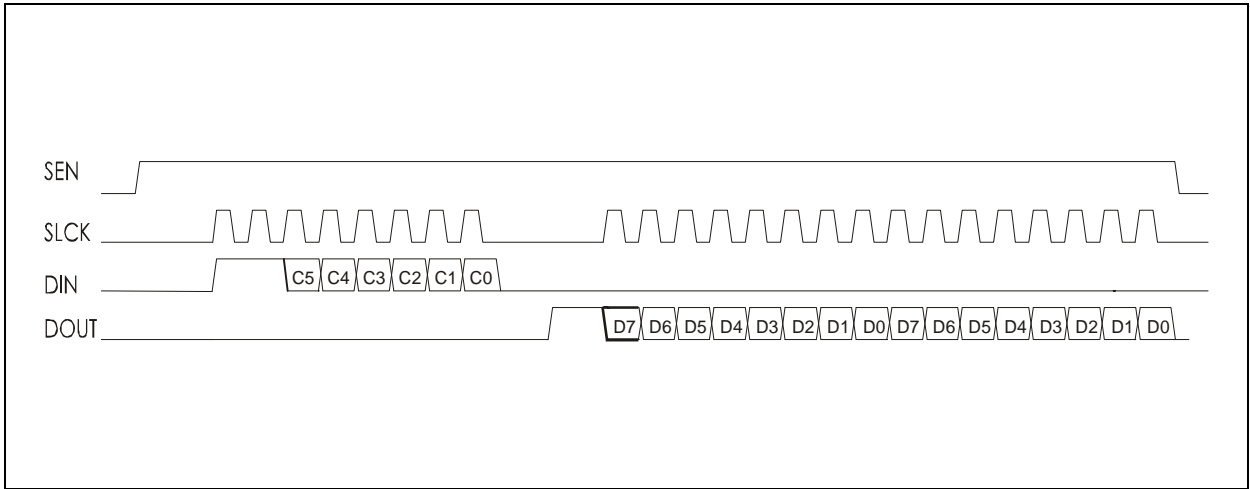

Figure 38:
SPI Write FIFO Command

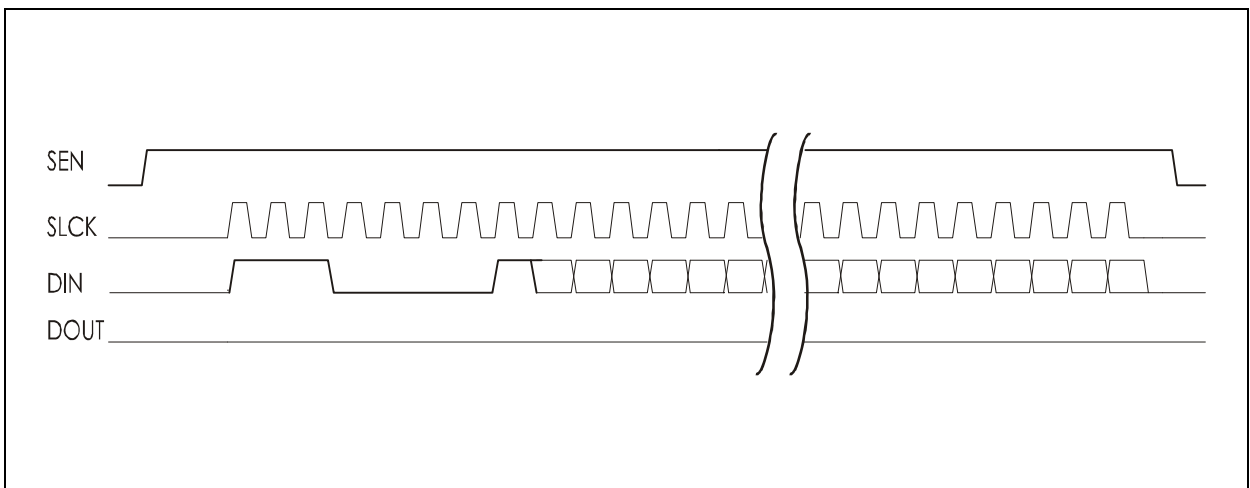
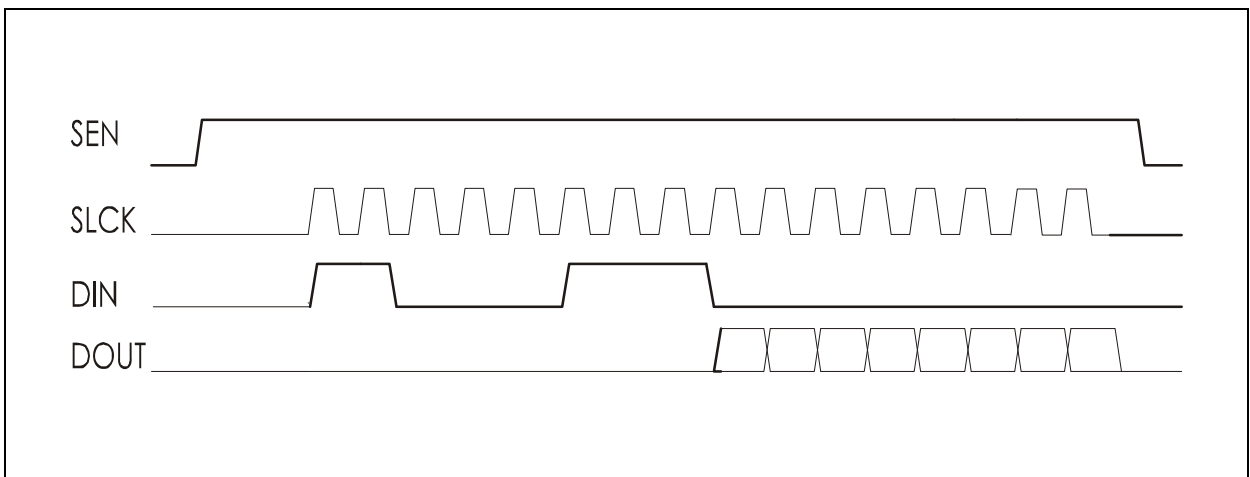

Figure 39:
SPI Read FIFO Status Command



SPI Direct Commands

Figure 40:
SPI Direct Commands

Command Code	Command	Comment
0x00	Reset command - same effect as POR	All calibration registers are refreshed from the EEPROM
0x01	Get temperature	After SDATAO signal goes high send additional 16 clock pulses for conversion data read-out
0x02	Get battery	After SDATAO signal goes high send additional 16 clock pulses for conversion data read-out
0x03	Get Ext. sensor 1	After SDATAO signal goes high send additional 16 clock pulses for conversion data read-out
0x04	Get Ext. sensor 2	After SDATAO signal goes high send additional 16 clock pulses for conversion data read-out
0x05	Start Logging	Starts the timer or IRQ mode - generates the sta_log pulse signal - the start time has to be written before with the SPI Write mode
0x06	Stop Logging	Stops the timer or IRQ mode - generates the end_log pulse signal
0x07	Read FIFO status	Read the FIFO status byte (8-bit)
0x08	Read Remaining shelf life	Reads the remaining shelf life (24-bit)
0x20	Read FIFO	Reads up to 8 bytes from the FIFO
0x21	Write FIFO	Writes up to 8 bytes to the FIFO

FIFO

The SL900A device has an integrated 8-byte FIFO register that can be used for fast data transmission between the RFID reader and the microcontroller that is connected to the SPI port.

The FIFO status can be determined by reading the FIFO status register:

Bit #	Function
7	FIFO busy
6	Data ready
5	No data
4	0 – data from SPI, 1 – data from RFID
3	Number of valid bytes in FIFO register (0000 – FIFO empty, 0001 – 1 byte, 1000 – 8 bytes)
2	
1	
0	

The FIFO can be read and written from the SPI and the RFID interface. From the RFID interface, the ACCESS FIFO command is used to access the FIFO register and the FIFO status. From the SPI interface, 3 commands are used – 0x07, 0x20 and 0x21. The 0x07 commands reads the FIFO status byte. Up to 8 bytes can be read from the FIFO with the 0x20 command and up to 8 bytes written with the 0x21 command.

Alternate Pad Functions

Some functions are multiplexed on same pads, so some functions of the device can not be used in parallel.

Manual Log Start with Button

The SL900A device supports 2 delayed start possibilities for the logging. Delayed start means that the logging is not started immediately when the device receives the Start Log command, but some time after the reception of this command. The application can set a fixed delay for the logging, or the logging can be started manually (without a RFID reader).

Figure 41 shows the external push button connection for the manual delayed start function. The DIN pin has an integrated pull-down resistor, so the only required external component is the button. When the DIN pin is connected to V_{BAT} , the logging will be started.

Figure 41:
Push Button Connection

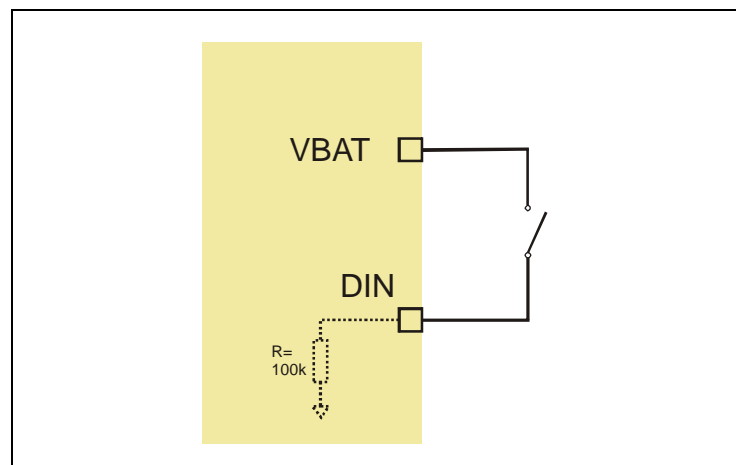

In order to enable this function, the application needs to set the "Delay mode" bit to 1. This is done with the "Initialize" command on page 37

External Shelf Life Alarm Function

The SL900A device can generate an alarm when the Shelf Life algorithm is used and the shelf life expires. The EXC pin is used for this function.

This signal can be used as an interrupt on a microcontroller, or can be directly used to drive a LED diode. The EXC driver resistance is 400Ω .

Figure 42 shows how to connect an LED diode to the EXC pin. This is possible only when the transponder uses a 3V battery supply as most of the LED diodes have a threshold above 1.5V. Depending on the type of the LED diode, also an external current-limiting resistor needs to be used.

Figure 42:
LED Connection for Shelf Life Alarm

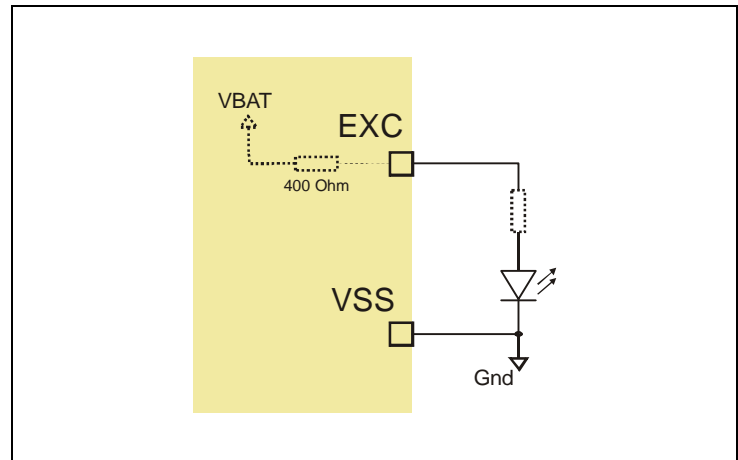

The external alarm function is activated automatically when the Shelf Life algorithm is used. The "sw_ext_en" bit in Calibration data has to be 0. If the "sw_ext_en" bit is set to 1, the EXC pin is used for external sensor supply.

External Sensor Front-End (SFE) The SL900A device can process the internal temperature sensor, the battery voltage and up to 2 external sensors. The result of the A/D conversion can be logged to the EEPROM or sent directly back to the interrogator (if the GET SENSOR VALUE command is used). The external sensors and the integrated temperature sensor can only be processed in serial manner. This is done through a multiplex amplifier, as the SL900A device has only one A/D converter integrated.

Figure 43:
External Sensor Front End

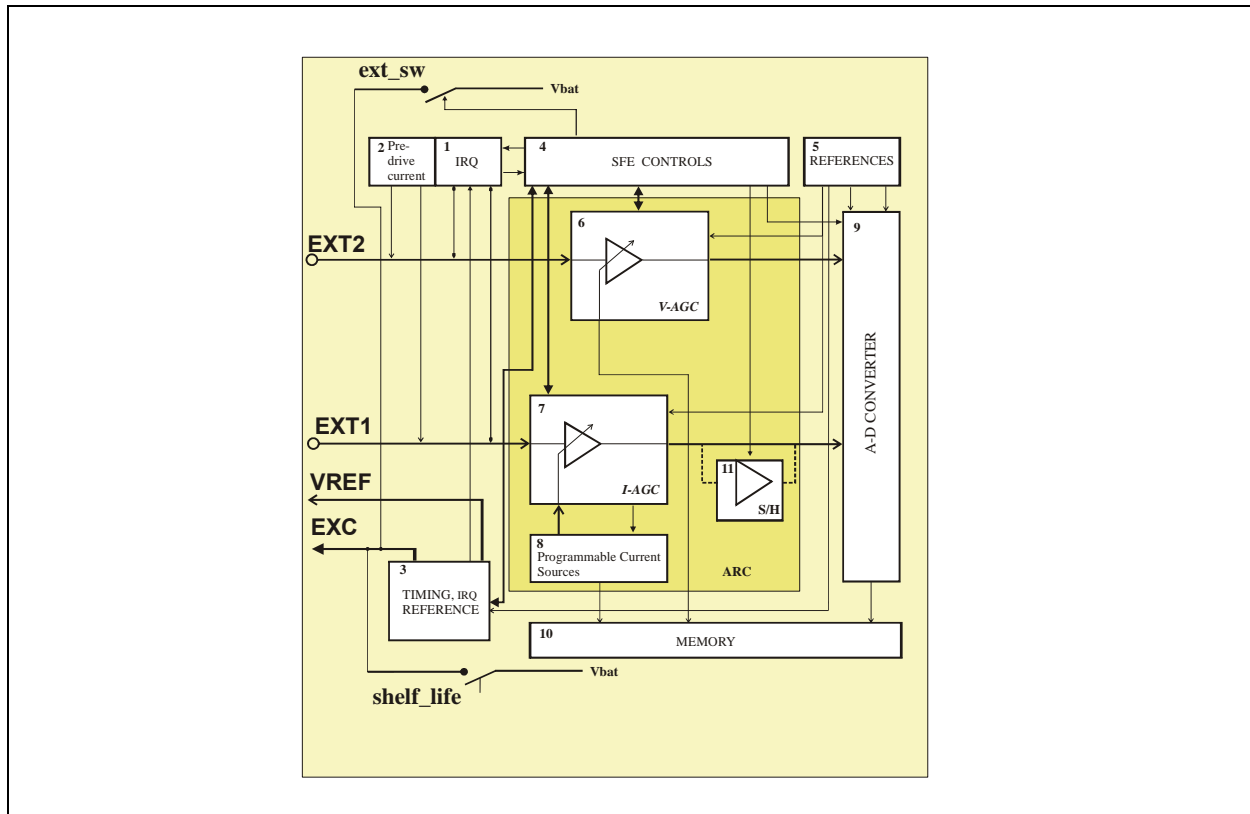

SFE Interface

The external sensor interface consists of 4 pads:

- **EXT1** – connection for external sensor 1 that can be a linear-resistive sensor, a DC voltage source (sensor with external analog processing), capacitive and resistive sensors with AC driving,
- **EXT2** – connection for external sensor 2 that can be a linear-conductive sensor, a reverse-polarized diode, DC voltage source with serial resistance or a DC current source to V_{SS} ,
- **EXC** – supply voltage for the external sensors or a AC signal source for external sensors that do not allow a DC voltage.
- V_{REF} – reference voltage (V_{O2}) pin used for capacitive and resistive sensors with AC excitation.

The SFE can be used for measurements with resistive sensors with linear resistance or conductance. It can be used for capacitive sensors and optical sensors (diode). It can also be used for connecting integrated sensors with voltage output (high impedance input).

The SFE allows a connection of a resistor bridge sensor arrangement, where the bridge is supplied by the EXC pad (battery voltage) and the 2 sensing points are attached to the EXT1 and EXT2 inputs. The 4th point of the resistive bridge has to be attached to the V_{SS} point. The AD conversion for the 2 sensing points is done with 2 successive measurements. First the EXT1 point and next the EXT2 point. The final calculation has to be done in the application software.

Also a capacitive or resistive sensor that does not allow a DC voltage can be attached to the SFE. In this case, the sensing point is the EXT1 input, the AC stimulus signal is provided by the EXC pin and the V_{REF} pad outputs an adjustable DC reference voltage.

SFE Interface

Figure 44:
Sensor Front End Setting Bits

SFE Group Bits	Function	Description
rang[4:0]	External sensor 2 range	Resistor feedback ladder – see application note for SFE
seti[4:0]	External sensor 1 range	Current source value – see application note for SFE
EXT1[1:0]	external sensor 1 type	00 – linear resistive sensor
		01 – high impedance input (voltage follower), bridge
		10 – reserved
		11 – capacitive or resistive sensor without DC (AC signal on EXC pin)
EXT2	external sensor 2 type	0 – linear conductive sensor, opto sensor, current source sensor
		1 - high impedance input (voltage follower), bridge
Range preset	Use preset range	Autorange function is turned off
Verify sensor ID[1:0]	Sensor used in limit check (sensor enable bits in log mode group)	00 – first selected sensor
		01 – second selected sensor
		10 – third selected sensor
		11 – fourth selected sensor

The external sensor interface has an auxiliary output pin (EXC) that can be used for supplying the external sensor either with a constant voltage or with an AC voltage signal (for capacitive sensor).

Figure 45:
EXC Output Pin Operation

EXC Pin Controls				
EXT1 [1:0]	sw_ext_en	stand-by mode	EXC Signal Output	Comment
00	0	0	HI-Z	The output drivers are disconnected
00	0	1	HI-Z	The output drivers are disconnected
11	X	X	AC signal during external sensor conversion	Is to be used only with capacitive sensors
00	1	0	V _{BAT}	The output is connected to the battery voltage for the duration of the conversion
00	1	1	HI-Z	The output drivers are disconnected
00	1	0	V _{BAT}	The output is connected to the battery voltage for the duration of the conversion
00	1	1	HI-Z	The output drivers are disconnected

External Sensor 1 Interface

The external sensor 1 interface (EXT1 pin) can be used for measurements with linear resistive sensors and capacitive sensors with AC excitation. It can also be used to measure 1 point of a resistive bridge (with the second point connected to the EXT2 pad).

The processing of an external capacitive sensor without DC voltage is possible in case an external reference capacitor is used. The external sensor in this case is excited with an AC signal from the EXC pin. The connection for this kind of sensors is shown on [Figure 46](#).

Figure 46:
External Capacitive Sensor with AC Excitation (EXT1[1:0] = 11)

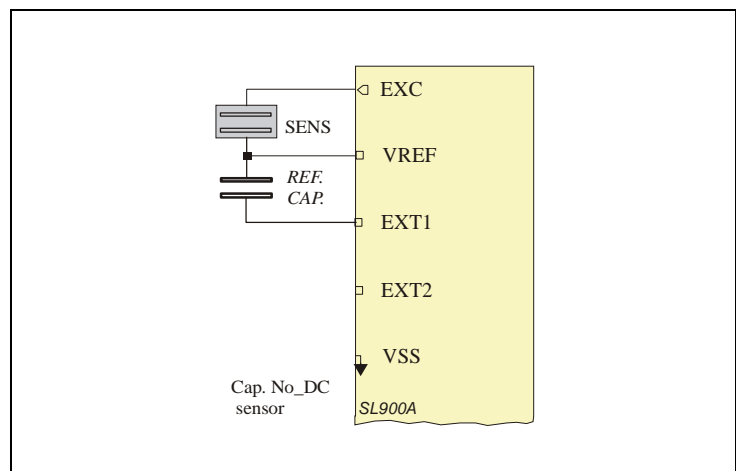

The external capacitive sensor in [Figure 46](#) is excited with a square wave signal around the reference voltage V_{REF} . The amplitude of the AC signal is equal to the V_{REF} voltage. Input AC amplitude:

$$V_{EXT1} = V_{EXC} \cdot \frac{C_{REF \cdot CAP}}{(C_{REF \cdot CAP} + C_{SENS})}$$

The selection of the reference capacitor depends on the AD converter input voltage range. The input AC amplitude V_{EXT1} at minimum capacitance C_{SENS} must be at a maximum AD level:

$$V_{AD_max} = 2 \cdot V_{v02} - V_{v01}$$

The input AC amplitude V_{EXT1} at minimum capacitance C_{SENS} must be close to minimum AD level:

$$V_{AD_min} = V_{v02}$$

The external sensor interface can also be used for resistive sensor with linear resistance and with resistive sensor that do not allow any DC voltage (AC excitation). The connection diagrams are on [Figure 47](#) and [Figure 48](#).

For a resistive sensor with AC excitation The following relation is valid:

$$V_{VREF} < V_{VREF} + \frac{V_{VREF}}{R_{R_SENS} + R_{REF \cdot RES}} \cdot R_{REF \cdot RES} \leq V_{VREF} + v_{01}$$

The proper ratio between sensor and reference resistor can be chosen to fulfill the upper relation and the range of sensor's resistivity.

Figure 47:
External Linear Resistive Sensor (EXT1[1:0] = 00)

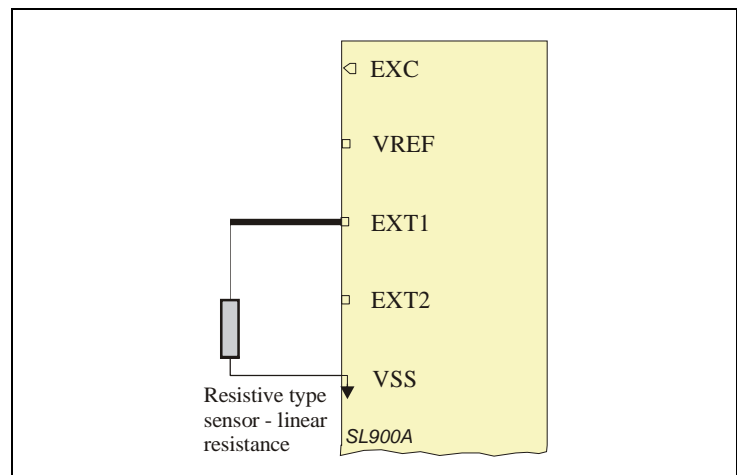

An additional external reference resistor has to be used for processing external resistive sensor with AC exciting.

Figure 48:
External Resistive Sensor with AC Signal (EXT1[1:0] = 11)

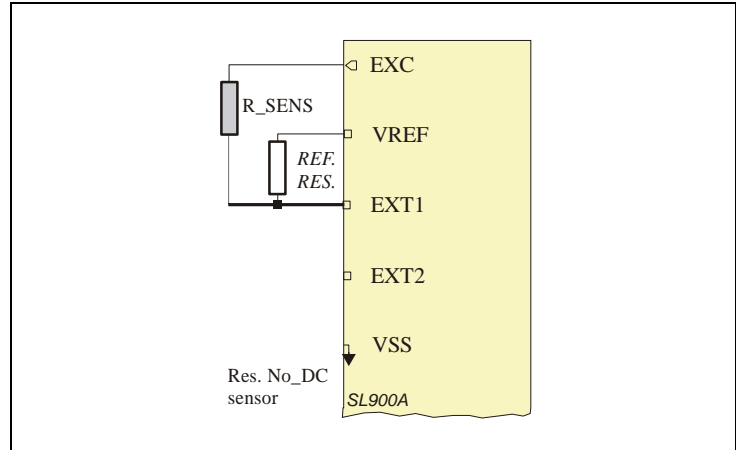

A resistive bridge has to be connected to both sensor inputs (Figure 49). The 2 input voltages are converted one after the other. In automatic logging, both external sensors have to be enabled. If the resistor bridge is also used with the GET SENSOR VALUE RFID command, this command has to be sent twice – first for external sensor 1, second for external sensor 2.

Figure 49:
Resistor Bridge Sensor (EXT1[1:0] = 01, EXT2 = 1)

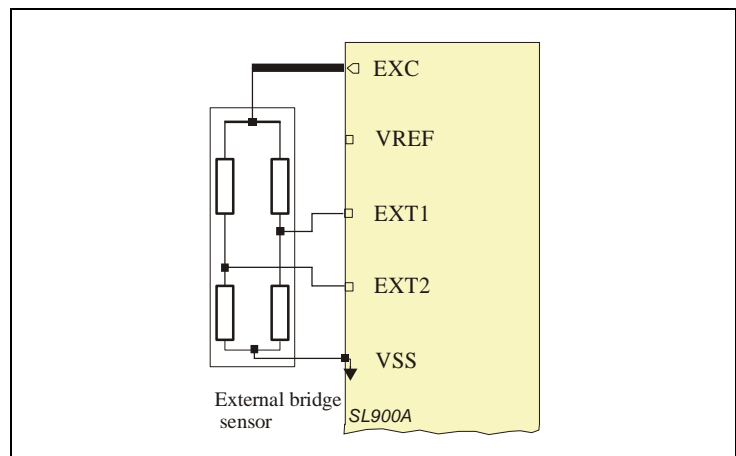

External Sensor 2 Interface

The external sensor 2 interface (EXT2 pin) can be used for measurements with linear conductive sensors, optical sensors (diode) and to measure the second point of a resistive bridge (with the first point connected to the EXT1 pad) (see Figure 49).

The Figure 50 shows the connection diagram for a resistive sensor with linear conductance (like a pressure sensor).

Figure 50:
External Resistive Sensor - Linear Conductance (EXT2 = 0)

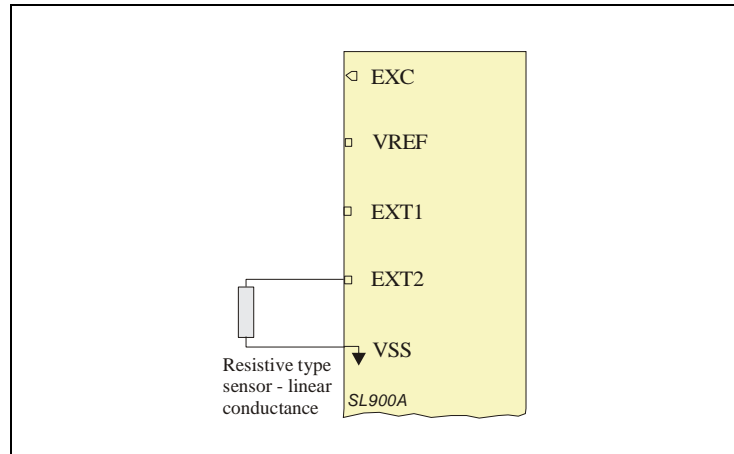

The EXT2 pad can also be used for measurements with an optical sensor based on reverse polarized diode current (Figure 51).

Figure 51:
External Optical Sensor (EXT2 = 0)

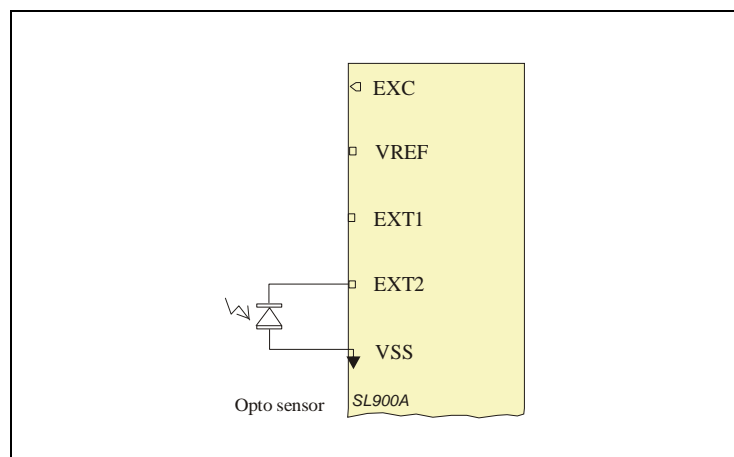

A voltage source output sensor can be connected to the EXT2 pin. This can be used for integrated sensors with an analog output signal.

Figure 52:
External Voltage Source Sensor (EXT2 = 1)

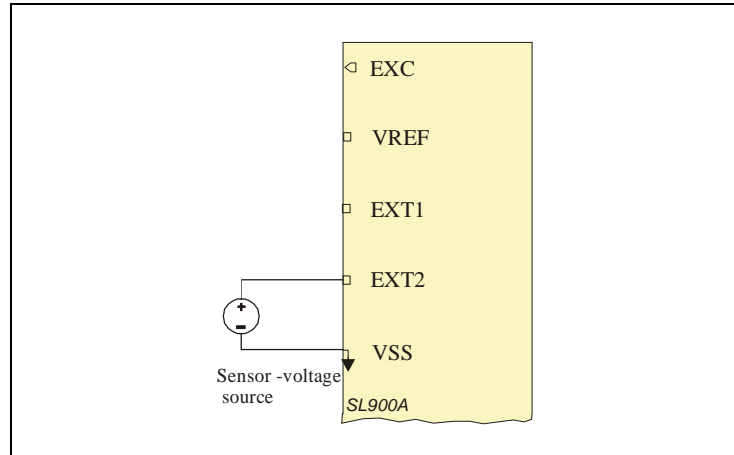

The EXT1 interface can also be used for external current source output sensors (Figure 53).

Figure 53:
External Current Source Sensor (EXT2 = 0)

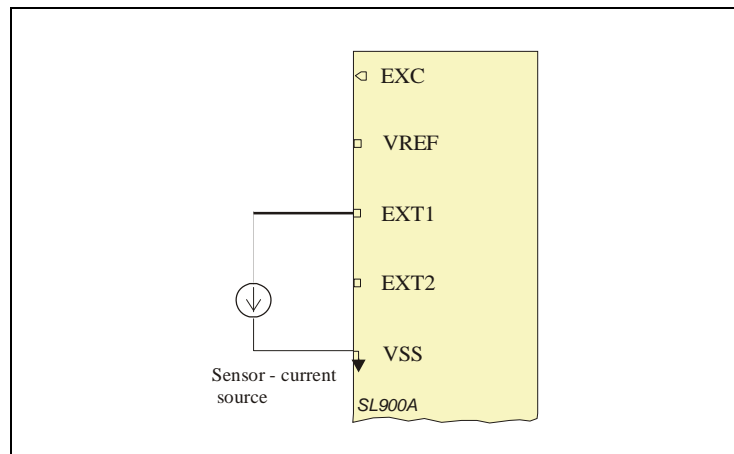

External Sensor Interface Settings

The external sensor interface is set up either with the SPI interface or with RFID custom commands. The commands required for external sensor operation are: SET LOG MODE, SET SFE PARAMETERS, SET CALIBRATION DATA and INITIALIZE.

The SET LOG MODE command is used to setup various parameters required for the automatic logging process. The command is described in "Set Log Mode" on page 30. If external sensors are used in the logging process, they have to be enabled with this command.

The SET SFE PARAMETERS command ("Set SFE Parameters" on page 33) is used to set up the SFE functionality. The SFE can be used as an automatic range selection block, for sensors with a

wide output range. It can also be used as a fixed gain preamplifier for sensors with a low output range. In this case, the user application has to preset the range and enable the preset values. The preset range has to be selected in case the internal limits are used with an external sensor.

The EXT1 interface gain is preset with the “seti [4:0]” field. The EXT2 gain is preset with the “rang [4:0]” field. The preset values are enabled with the “Autorange Preset” flag.

The external sensor type “EXT1[1:0]” and “EXT2” can be set with the SET SFE PARAMETERS command. This command is also used for selecting the sensor (“Verify Sensor ID”) that will be used with the limits in out of limits logging mode.

The SET CALIBRATION DATA command is used to set up the supply switch for external sensors (“sw_ext_en”) and to setup the interrupt voltage level for external sensors (“irlev[1:0]”). The external sensors can be supplied with the battery voltage from the EXC pin only during the conversion time. This will save power compared to a system where the sensor is supplied directly from the battery. This is especially useful for a resistive bridge sensor.

The INITIALIZE command is used to setup interrupt and timer logging modes in parallel (“IRQ + timer enable” flag). This special logging mode can be used for regular interval-based sensor sampling combined with the interrupt capability of the SFE.

External Sensor Interrupt

The external sensor interface can be used for sampling short events on the EXT1 and EXT2 pins. This can be used for shock sensors, acceleration sensors and other pulse response sensors. It is also useful for counting events on the external sensor pins.

The sensors are pre-driven with a small current of 125nA and are constantly observed with a very low consumption comparator. The overall current consumption of the interrupt block is 0.5µA at room temperature. In case the sensor voltage exceeds the specified threshold (“irlev[1:0]”), the SFE will generate an IRQ request. This will wake up the whole system and the sensor data, together with the real time information, will be logged to the memory.

The interrupt mode is selected with the SET LOG MODE command with the "Logging Mode[2:0]" field ("[Logging Formats](#)" on page 41). The implemented IRQ modes are:

Figure 54:
IRQ Logging Modes

Bit 2	Bit 1	Bit 0	Logging Form	Description
1	0	1	IRQ, EXT1	Interrupt triggered on the EXT1 external sensor input
1	1	0	IRQ, EXT2	Interrupt triggered on the EXT2 external sensor input
1	1	1	IRQ, EXT1, EXT2	Interrupt triggered on the EXT1 and EXT2 external sensor input

Either of the 2 external sensor pads, or both of them, can be used for generating an interrupt. This function can also be used for button-triggered measurements, as the user can select which sensor will be logged during an interrupt event.

The interrupt level can be selected by the application with the SET CALIBRATION DATA command ("irlev[1:0]"). The setting is valid for EXT1 and EXT2.

Figure 55:
Sensor Front End Setting Bits

Irlev [1:0]		EXT1 resistive – [MΩ]	EXT2 resistive - [MΩ]	IRQ level - % of supply voltage
Bit 1	Bit 0			
0	0	< 3	< 3	< 25 %
0	1	< 1	< 1	< 8 %
1	0	< 4.2	< 4.2	< 35 %
1	1	< 5.2	< 5.2	< 43%

The IRQ threshold varies from chip to chip for a maximum of ±25% from its nominal specified value. The ratio between levels at different IRQ-level-CODE remains constant. The IRQ voltage levels are supply ratiometric.

Calibration Bits

The SL900A chip is factory calibrated. The calibration settings can be modified by the application. Some values in the calibration data field should not be modified by the application as this could degrade the temperature performance and the communication stability. Those values are highlighted in the table as **DO NOT MODIFY**.

The individual bits in the calibration field are:

Calibration	Function	Range		
		Min	Max	Step
ad1[4:0]	AD lower voltage reference - fine – DO NOT MODIFY	-10mV	+10mV	0.625mV
coars1[2:0]	AD lower voltage reference - coarse – can be used	160mV	510mV	50mV
ad2[4:0]	AD higher voltage reference - fine – DO NOT MODIFY	-10mV	+10mV	0.625mV
coars2[2:0]	AD higher voltage reference - coarse	260mV	610mV	50mV
gnd_switch	Switches the lower AD voltage reference to ground (default = 1)	0		
selp12[1:0]	POR voltage level for 1.5V system	LH -1.04V HL -0.98V	LH - 1.17V HL - 1.11V	
adf[4:0]	Main reference voltage calibration – DO NOT MODIFY	622mV	648mV	0.86mV
df[7:0]	RTC oscillator calibration	800Hz	1165Hz	~1Hz (non linear)
sw_ext_en	Controlled battery supply for external sensor – the battery voltage is connected to the EXC pin			
selp22[1:0]	POR voltage level for 3V system	LH - 1.95 V HL - 1.84V	LH - 2.19V HL - 2.07V	

Calibration	Function	Range		
		Min	Max	Step
irlev[1:0]	Voltage interrupt level for external sensor - ratiometric	8% of V _{BAT}	43% of V _{BAT}	8%, 25%, 35%, 43%
ring_cal[4:0]	Main system clock oscillator calibration – DO NOT MODIFY	1585kHz	2590kHz	31kHz
off_int[6:0]	Temperature conversion offset calibration – DO NOT MODIFY	-32LSb	+32LSb	1LSb
reftc[3:0]	Bangap voltage temperature coefficient calibration – DO NOT MODIFY	450mV	472mV	~18ppm/C
exc_res	excitate for resistive sensors without DC			
RFU[1:0]	RESERVED			

Note(s) and/or Footnote(s):

1. LH – POR level rising supply
2. HL – POR level falling supply

Shelf Life Calculation

The SL900A device has an integrated shelf life algorithm that can dynamically calculate the remaining shelf life of the product.

It is a look-up table algorithm, where the look-up table is stored in the first 60 bytes of the User bank. The look-up table can be programmed with the standard EPC Write command, or through the SPI interface.

Figure 56:
Shelf Life Look-up Table

Physical Address	Bank	Bank Name	Logical Address	Content
0x064	3	USER	0x000	P[0] - lookup table start
0x065				P[1]
~			~	
~			~	
0x09E			0x01D	P[58]
0x09F				P[59] - lookup table end

The Shelf life algorithm can work with either the integrated temperature sensor or with an external sensor. The sensor that will be used with this algorithm can be selected with the SET SHELF LIFE command.

Shelf Life Sensor ID [1:0]

Figure 57:
Shelf Life Sensor ID

B1	B0	Sensor Type
0	0	Temperature sensor
0	1	Ext. sensor 1
1	0	Ext. sensor 2
1	1	Battery voltage

The Shelf life algorithm is enabled with the “Enable Shelf Life” flag in the SET SHELF LIFE command. The algorithm is activated with the START LOG command. With this command, the calibration data is loaded from EEPROM to the calibration registers, the initial shelf life is set and the shelf life parameters are set up.

Figure 58:
Shelf Life Memory Block

Physical Address	Content	Block
0x030	Tmax[7:0]	Shelf Life block 0
0x031	Tmin[7:0]	
0x032	Tstd[7:0]	
0x033	Ea[7:0]	
0x034	SLinit[15:8]	Shelf Life block 1
0x035	Slinit[7:0]	
0x036	Tinit[9:2]	
0x037	Tinit[1:0]	
	ShelfLife Sensor ID [1:0]	
	Enable Negative ShelfLife	
	Shelf life algorithm enable	
	RFU [1:0]	

The values in the Shelf life block 0 are not used in any calculations in the chip. They are intended as reference information purposes for the interrogator.

Figure 59:
Shelf Life Block 0

Block	Data Field	Function
Shelf Life block 0	Tmax[7:0]	Maximal temperature for the product
	Tmin[7:0]	Minimum temperature for the product
	Tstd[7:0]	Normal temperature
	Ea[7:0]	Activation energy

The Shelf life block 1 holds the information on the initial shelf life and the initial temperature. Both of those values are used in the shelf life algorithm.

Figure 60:
Shelf Life Block 1

Block	Data Field	Function
Shelf Life block 1	SLinit[15:0]	Initial shelf life
	Tinit[9:0]	Initial temperature used in the shelf life calculation
	ShelfLife Sensor ID [1:0]	Sensor used for shelf life calculation (temperature, external 1 or external 2)
	Enable Negative Shelf life	Enables negative values for shelf life
	Shelf life algorithm enable	Enables the shelf life algorithm
	RFU [1:0]	Reserved for future use

The remaining shelf life is a 24-bit word. The remaining shelf life, shelf life block 0&1 and the status flags can be read out with the GET LOG STATE command ([“Get Log State” on page 35](#)).

Figure 61:
Status Flags

Bit #	Function
7	Active (logging process)
6	Measurement area full
5	Measurement overwritten
4	AD error
3	Low battery
2	Shelf life low error (SLerrlo)
1	Shelf life high error (SLerrhi)
0	Shelf life expired

When the shelf life reaches 0, the chip can generate a signal on the EXC pin that can be used as an interrupt source

The remaining shelf life can be read from the SPI interface with the 0x08 SPI command.

The following is a C language representation of the shelf life algorithm, implemented in SL900A.

At startup of logging:

```
SLcurr (22 bits, signed) = SLinit << 6; // multiply by 64
SLerrlo = 0;
SLerrhi = 0;
```

At each temperature logging event:

```
Tdiff (10 bits, unsigned) = Tmeas (10 bits, temperature
value) – Tinit;
Tindex (8 bits, unsigned) = Tdiff >> 2; // divide by 4
if (Tdiff > 236) {SLerrhi++; Tindex = 59}
if (Tinit > Tmeas) {SLerrlo ++; Tindex = 0}
Counter (8 bits, unsigned) = 0;
While (Counter <= Tindex)
{
    SLdec (8 bits, unsigned) = P[Counter];
    SLcurr = SLcurr – SLdec;
    Counter++;
}
if (Tindex & (Tindex < 59)) // Interpolation process
{
    SLdec++; // compensate for truncation
    if (Tdiff & 0b00000010) {SLcurr = SLcurr – (SLdec
>> 1)}
    if (Tdiff & 0b00000001) {SLcurr = SLcurr – (SLdec
>> 2)}
}
```

Memory Map Overview

Figure 62:
Memory Map Overview

Loc. #	Physical Address	Bank	Bank Name	Logical Address	Content	Group
1	0x000	X	SYSTEM		System Password [31:24]	System Password - read protect
2	0x001				System Password [23:16]	
3	0x002				System Password [15:8]	System Password - write protect
4	0x003				System Password [7:0]	
5	0x004				User Password [31:24]	User Password - read protect
6	0x005				User Password [23:16]	
7	0x006				User Password [15:8]	User Password - write protect
8	0x007				User Password [7:0]	
9	0x008				Measurement Password [31:24]	Measurement Password - read protect
10	0x009				Measurement Password [23:16]	
11	0x00A				Measurement Password [15:8]	Measurement Password - write protect
12	0x00B				Measurement Password [7:0]	
13	0x00C				Year [5:0]	Start time
					Month [3:2]	
14	0x00D				Month [1:0]	
					Day [4:0]	
15	0x00E		Hour [4]			
			Hour [3:0]			
16	0x00F		Minute [5:2]			
			Minute [1:0]			
			Second [5:0]			

Loc. #	Physical Address	Bank	Bank Name	Logical Address	Content	Group
17	0x010	X	SYSTEM		ad1[4:0] - reference voltage 1 fine cal.	Calibration
					coars1[2:0] - reference voltage 1 coarse cal.	
18	0x011				ad2[4:0] - reference voltage 2 fine cal.	
					coars2[2:0] - reference voltage 2 coarse cal.	
19	0x012				gnd_switch	
					selp12[1:0] - 1.5V battery POR level	
					adf[4:0] - 635mV reference voltage cal.	
					df[7:0] - timer oscillator cal.	
20	0x013				sw_ext_en - switched battery supply for ext. sensor	
					selp22[1:0] - 3V battery POR level	
					irlev[1:0]	
					ring_cal[4:2] - 1.92MHz oscillator cal.	
21	0x014				ring_cal[1:0]	
					off_int[6:1] - temperature offset calibration	
22	0x015				off_int[0]	
					reftc[3] - band gap temperature coefficient cal.	
23	0x016				reftc[2:0] - band gap temperature coefficient cal.	
					exc_res - excitate for resistive sensors without DC	
					RFU[1:0]	

Loc. #	Physical Address	Bank	Bank Name	Logical Address	Content	Group
24	0x017	X	SYSTEM		rang[4:0] - ext. sensor 2 range (feedback resistor)	SFE parameters
					seti[4:2] - ext. sensor 1 range (current source)	
25	0x018				seti[1:0] - ext. sensor 1 range	
					sext1[1:0] - external sensor 1 type	
					sext2 - external sensor 2 type	
					Auto range preset	
					Verify sensor ID[1:0]	
26	0x019				Extreme lower limit [9:2]	Limits
27	0x01A				Extreme lower limit [1:0]	
					Lower limit [9:4]	
28	0x01B				Lower limit [3:0]	
					Upper limit [9:6]	
29	0x01C				Upper limit [5:0]	
					Extreme upper limit [9:8]	
30	0x01D		Extreme upper limit [7:0]			
31	0x01E		Ext. lower limits counter [7:0]	Limits counter		
32	0x01F		Lower limits counter [7:0]			
33	0x020		Higher limits counter [7:0]			
34	0x021		Ext. higher limits counter [7:0]			

Loc. #	Physical Address	Bank	Bank Name	Logical Address	Content	Group
35	0x022	X	SYSTEM		Measurement address pointer [9:2]	System status
36	0x023				Measurement address pointer [1:0]	
37	0x024				Number of memory replacements [5:0]	
38	0x025				Number of measurements [14:7]	
					Number of measurements [6:0]	
					Active	
					Logging form [2:0]	Log mode
39	0x026				Storage rule (0 - normal, 1 - rolling)	
					Ext.1 sensor enable	
					Ext.2 sensor enable	
					Temp. sensor enable	
					Battery check enable	
40	0x027				Log interval [14:7]	Log interval
41	0x028				Log interval [6:0]	
					RFU	
42	0x029				Delay time [11:4]	Delay time
			Delay time [3:0]			
			Single use flag			
43	0x02A		RFU			
			Delay mode (0 - timer or 1 - switch)			
			IRQ+timer enable			

Loc. #	Physical Address	Bank	Bank Name	Logical Address	Content	Group
44	0x02B	X	SYSTEM		Number of blocks for user data [8:1]	User data
45	0x02C				Number of blocks for user data [0]	
					RFU [3:0]	
					Broken word pointer [2:0]	
46	0x02D				RFU[7:0]	RFU
47	0x02E				Kill lock [1:0]	Lock bits, write ONLY with the 'Lock' command
					Access lock [1:0]	
					EPC [1:0]	
					TID lock [1:0]	
48	0x02F				USER lock [1:0]	
					RFU [5:0]	
49	0x030				Tmax[7:0]	Shelf Life block 0
50	0x031				Tmin[7:0]	
51	0x032				Tstd[7:0]	
52	0x033				Ea[7:0]	
53	0x034		SLinit[15:8]	Shelf Life block 1		
54	0x035		Slinit[7:0]			
55	0x036		Tinit[9:2]			
			Tinit[1:0]			
56	0x037		ShelfLife Sensor ID [1:0]			
			Enable Negative ShelfLife			
			Shelf life algorithm enable			
			Skip log [1:0]			

Loc. #	Physical Address	Bank	Bank Name	Logical Address	Content	Group		
57	0x038	X	SYSTEM		T1_delay [3:0]	Adjust bits for the T1 timer (default value is "0111")		
					FIRO_enable	Enable FIRO RNG		
					cl_sh_diss	Disables the clock shop		
					T2_diss	Disables the T2 timing		
					RFU	Reserved for future use		
58	0x039				RFU[6:0]	Reserved for future use		
59	0x03A				KILL	KILL flag		
59	0x03A				RFU[7:0]	RFU		
60	0x03B				RFU[7:0]			
61	0x03C				RFU[7:0]			
62	0x03D		RFU[7:0]					
63	0x03E		RFU[7:0]					
64	0x03F		RFU[7:0]					
65	0x040	0	RESERVED	0x00	Kill Password [31:24]	Kill Password		
66	0x041				Kill Password [23:16]			
67	0x042			0x01	Kill Password [15:8]			
68	0x043				Kill Password [7:0]			
69	0x044			0x02	Access Password [31:24]	Access Password		
70	0x045				Access Password [23:16]			
71	0x046				0x03		Access Password [15:8]	
72	0x047						Access Password [7:0]	
RAM - 1	RAM - 0x00			1	EPC	0x00	CRC-16 [15:8]	CRC-16 is stored in the RAM portion and is mapped to the EPC memory block
RAM - 2	RAM - 0x01						CRC-16 [7:0]	
73	0x048	0x01	PC [15:8]			PC		
74	0x049		PC [7:0]					

Loc. #	Physical Address	Bank	Bank Name	Logical Address	Content	Group
75	0x04A	1	EPC	0x02	EPC [127:120]	EPC
76	0x04B				EPC [119:112]	
77	0x04C			0x03	EPC [111:104]	
78	0x04D				EPC [103:96]	
79	0x04E			0x04	EPC [95:88]	
80	0x04F				EPC [87:80]	
81	0x050			0x05	EPC [79:72]	
82	0x051				EPC [71:64]	
83	0x052			0x06	EPC [63:56]	
84	0x053				EPC [55:48]	
85	0x054			0x07	EPC [47:40]	
86	0x055				EPC [39:32]	
87	0x056			0x08	EPC [31:24]	
88	0x057				EPC [23:16]	
89	0x058			0x09	EPC [15:8]	
90	0x059	EPC [7:0]				
91	0x05A	2	TID	0x00	TID [7:0] – 0xE0	TID (same format as UID in ISO 15693), READ ONLY
92	0x05B				TID [15:8] – 0x36	
93	0x05C			0x01	TID [23:16]	
94	0x05D				TID [31:24]	
95	0x05E			0x02	TID [39:32]	
96	0x05F				TID [47:40]	
97	0x060			0x03	TID [55:48]	
98	0x061				TID [63:56]	
99	0x062			0x04	Chip version [7:0]	Version, etc... READ ONLY
100	0x063				RFU [7:0]	

Loc. #	Physical Address	Bank	Bank Name	Logical Address	Content	Group
101	0x064	3	USER	0x000	USER memory start - UMI	USER / MEASUREMENT memory – 1052 bytes
102	0x065					
~	~			~		
~	~			~		
1151	0x47E			0x20D		
1152	0x47F				USER memory end	

Applications

Battery-Assisted Transponder – Temperature Data Logger

In the battery-assisted transponder application, only 4 pads are used – the antenna pads and the battery pads. This kind of circuit is suitable for a temperature data logger application.

Figure 63:
Battery-Assisted Transponder – Temperature Data Logger

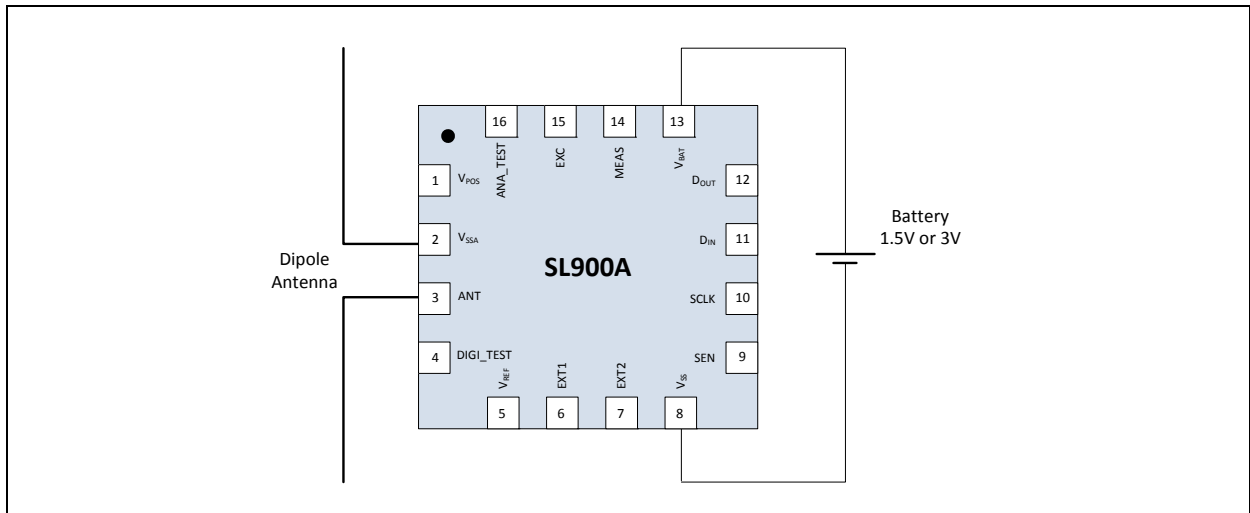

Passive Transponder – Passive Temperature Sensor

In the passive transponder, 2 pads are required for the antenna (ANT, V_{SSA}). For extended read range an external capacitor connected between the V_{POS} and V_{SS} pads is recommended.

Figure 64:
Passive Transponder – Passive Temperature Sensor

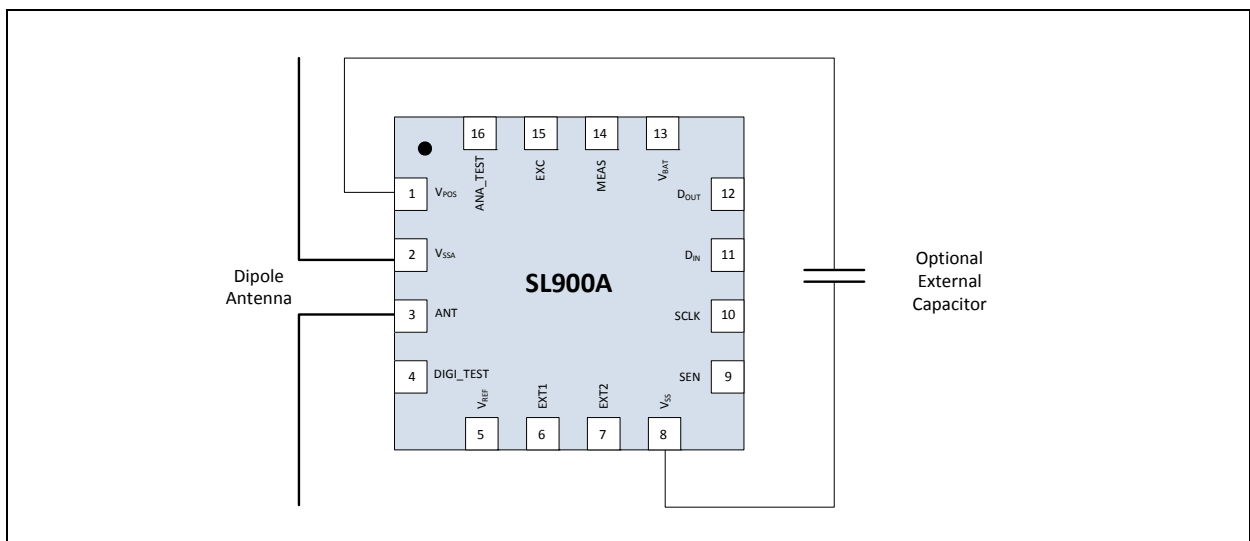

Battery-Assisted Transponder with External Microcontroller

An external microcontroller can be connected to the SL900A device using the SPI interface. The microcontroller can read and write the EEPROM, start and stop logging, perform an AD conversion and data can be transmitted to the RFID reader. The microcontroller can be used to perform additional tasks to extend the functionality of the system.

Figure 65:
Battery-Assisted Transponder with External Microcontroller

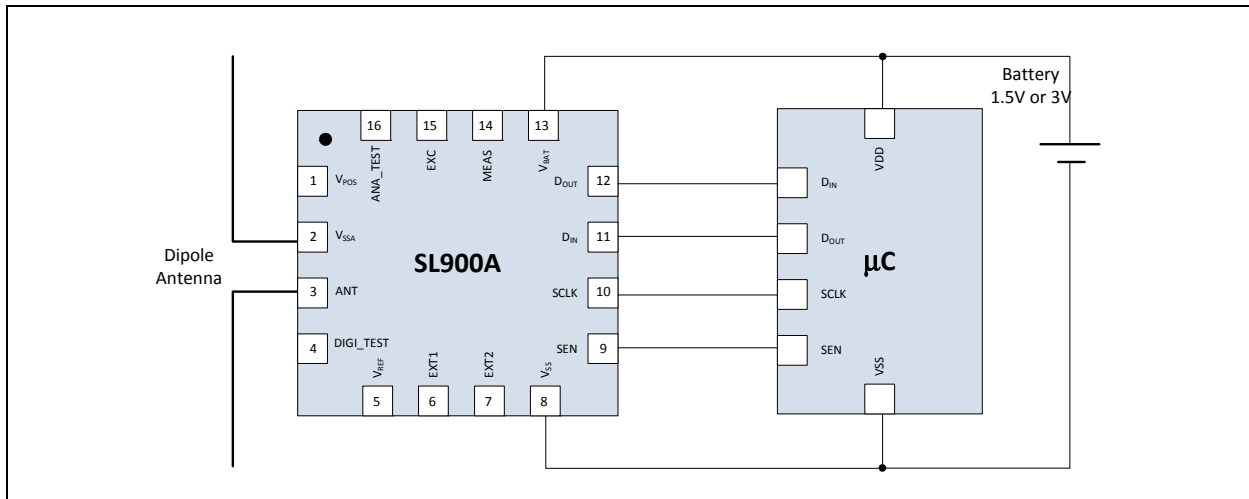

Battery-Assisted Transponder with Pushbutton for Manual Delayed Log Start

In the battery-assisted transponder application, 5 pads are used – the antenna pads, the battery pads and DIN for push button input. This kind of circuit is suitable for a temperature data logger application with manual logging start.

Figure 66:
Battery-Assisted Transponder with Pushbutton for Manual Delayed Log Start

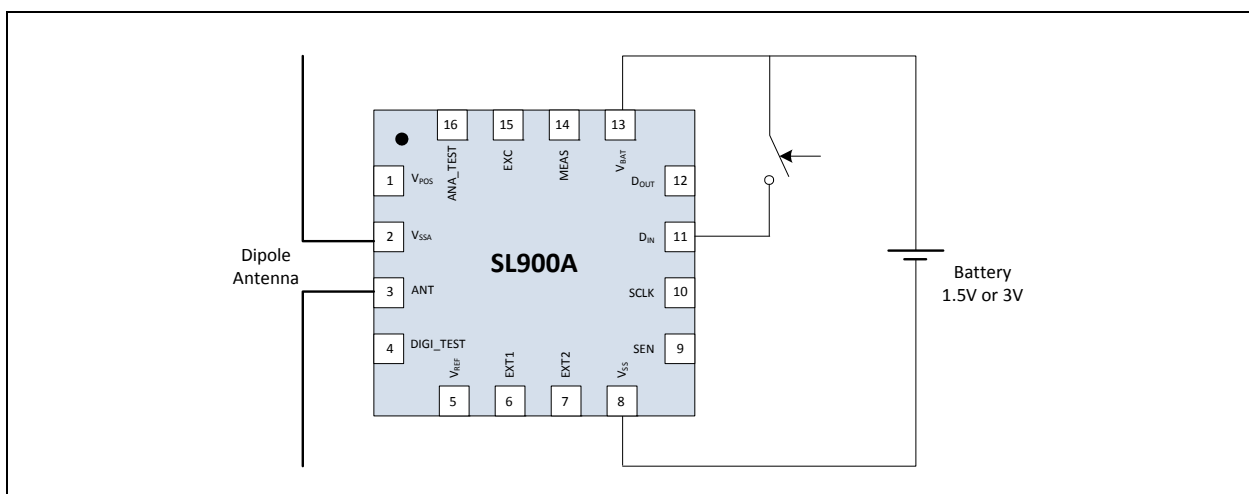

Dense Mode Logging – First 8 Measurements

This is a short representation of the Measurement memory, the address pointer and the measurement counter for dense logging mode with the integrated temperature sensor. Shown are only the first 8 measurements – all other measurements are stored in same manner.

Temperature data is: 0x2AA, 0x3FF, 0x2AA, 0x3FF, ...

Figure 67:
Dense Mode Logging – First 8 Measurements:

No Measurement:

0	00000000	00000000
1	00000000	00000000
2	00000000	00000000
3	00000000	00000000
4	00000000	00000000
5	00000000	00000000

Address pointer	0
Measurement counter	0
Broken Word Pointer	0

Measurement 1:

0	10101010	10000000
1	00000000	00000000
2	00000000	00000000
3	00000000	00000000
4	00000000	00000000
5	00000000	00000000

Address pointer	0
Measurement counter	1
Broken Word Pointer	5

Measurement 2:

0	10101010	10111111
1	11110000	00000000
2	00000000	00000000
3	00000000	00000000
4	00000000	00000000
5	00000000	00000000

Address pointer	1
Measurement counter	2
Broken Word Pointer	2

Measurement 3:

0	10101010	10111111
1	11111010	10101000
2	00000000	00000000
3	00000000	00000000
4	00000000	00000000
5	00000000	00000000

Address pointer	1
Measurement counter	3
Broken Word Pointer	7

Measurement 4:

0	10101010	10111111
1	11111010	10101011
2	11111111	00000000
3	00000000	00000000
4	00000000	00000000
5	00000000	00000000

Address pointer	2
Measurement counter	4
Broken Word Pointer	4

Measurement 5:

0	10101010	10111111
1	11111010	10101011
2	11111111	10101010
3	10000000	00000000
4	00000000	00000000
5	00000000	00000000

Address pointer	3
Measurement counter	5
Broken Word Pointer	1

Measurement 6:

0	10101010	10111111
1	11111010	10101011
2	11111111	10101010
3	10111111	11110000
4	00000000	00000000
5	00000000	00000000

Address pointer	3
Measurement counter	6
Broken Word Pointer	6

Measurement 7:

0	10101010	10111111
1	11111010	10101011
2	11111111	10101010
3	10111111	11111010
4	10101000	00000000
5	00000000	00000000

Address pointer	4
Measurement counter	7
Broken Word Pointer	3

Measurement 8:

0	10101010	10111111
1	11111010	10101011
2	11111111	10101010
3	10111111	11111010
4	10101011	11111111
5	00000000	00000000

Address pointer	5
Measurement counter	8
Broken Word Pointer	0

Package Drawings & Markings

Figure 68:
Package Drawings

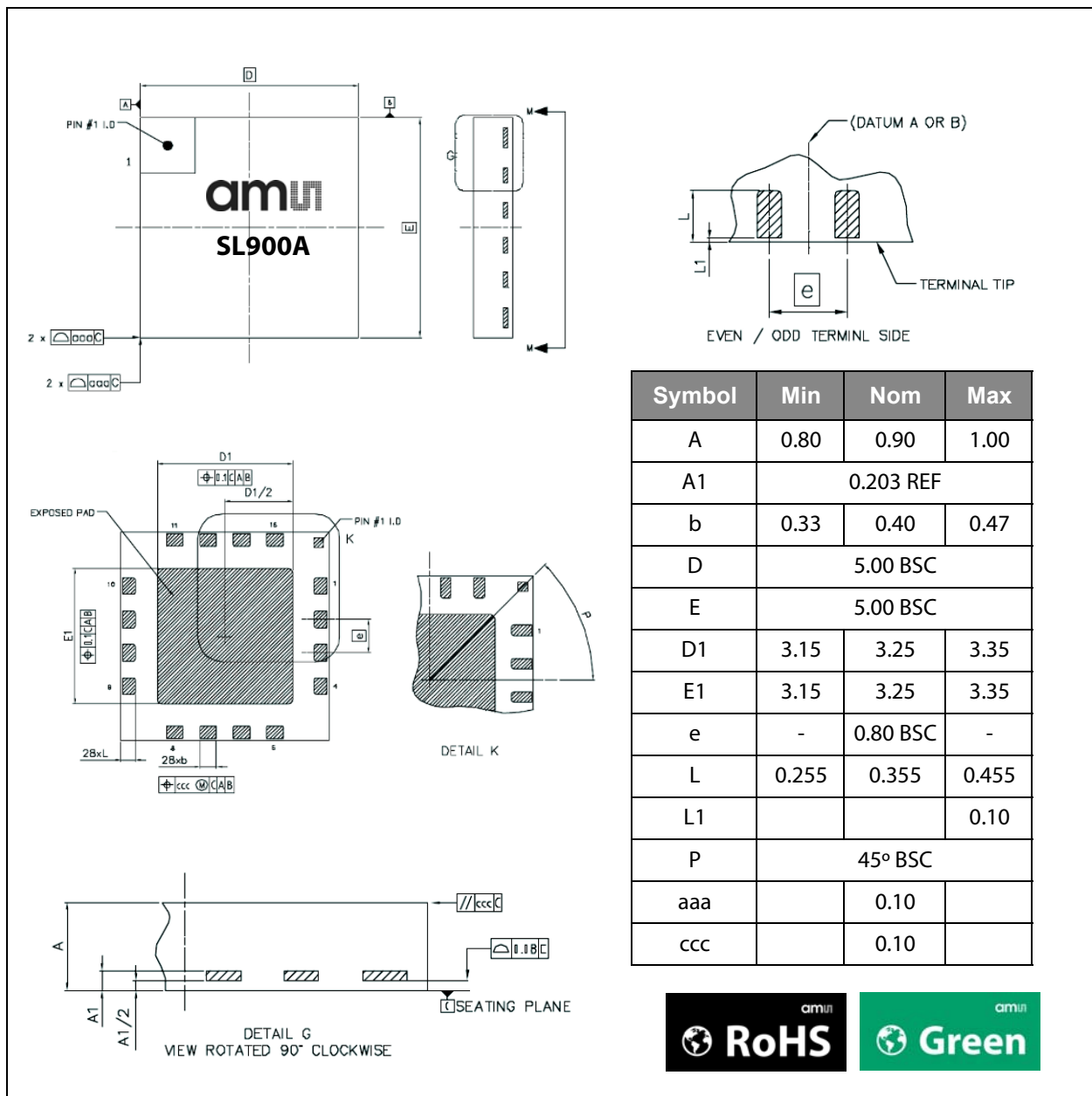

SL900A Package Drawings: The reflow peak soldering temperature (body temperature) is specified according IPC/JEDEC J-STD-020C "Moisture/Reflow Sensitivity Classification for Nonhermetic Solid State Surface Mount Devices".

Note(s) and/or Footnote(s):

1. Dimensioning and tolerances conform to ASME Y14.5M-1994.
2. All dimensions are in millimeters. Angles are in degrees.
3. Dimension b applies to metalized terminal and is measured between 0.25mm and 0.30mm from terminal tip. Dimension L1 represents terminal full back from package edge up to 0.1mm is acceptable.
4. Co-planarity applies to the exposed heat slug as well as the terminal.
5. Radius on terminal is optional.
6. This drawing is subject to change without notice.

RoHS Compliant & ams Green Statement

RoHS: The term RoHS compliant means that ams products fully comply with current RoHS directives. Our semiconductor products do not contain any chemicals for all 6 substance categories, including the requirement that lead not exceed 0.1% by weight in homogeneous materials. Where designed to be soldered at high temperatures, RoHS compliant products are suitable for use in specified lead-free processes.

ams Green (RoHS compliant and no Sb/Br): ams Green defines that in addition to RoHS compliance, our products are free of Bromine (Br) and Antimony (Sb) based flame retardants (Br or Sb do not exceed 0.1% by weight in homogeneous material).

Important Information: The information provided in this statement represents ams knowledge and belief as of the date that it is provided. ams bases its knowledge and belief on information provided by third parties, and makes no representation or warranty as to the accuracy of such information. Efforts are underway to better integrate information from third parties. ams has taken and continues to take reasonable steps to provide representative and accurate information but may not have conducted destructive testing or chemical analysis on incoming materials and chemicals. ams and ams suppliers consider certain information to be proprietary, and thus CAS numbers and other limited information may not be available for release.

Ordering & Contact Information

Figure 69:
Ordering Information

Ordering Code	Description	Operating Temperature Range	Package Type	Device Marking	Shipping Form
SL900A-AQFT	Smart active label IC with on-chip temperature sensor and 9k EEPROM	-40°C to 125°C	QFN 16 (5 x 5 mm)	SL900A	Tape & reel (1,000/reel)
SL900A-ASWB		-40°C to 125°C	-		Tested wafers

Ordering Information: Order quantities should be a multiple of shipping form.

Buy our products or get free samples online at:
www.ams.com/ICdirect

Technical Support is available at:
www.ams.com/Technical-Support

For further information and requests, e-mail us at:
ams_sales@ams.com

For sales offices, distributors and representatives, please visit:
www.ams.com/contact

Headquarters

ams AG
Tobelbaderstrasse 30
8141 Unterpremstaetten
Austria, Europe

Tel: +43 (0) 3136 500 0

Website: www.ams.com

Copyrights & Disclaimer

Copyright ams AG, Tobelbader Strasse 30, 8141 Unterpremstaetten, Austria-Europe. Trademarks Registered. All rights reserved. The material herein may not be reproduced, adapted, merged, translated, stored, or used without the prior written consent of the copyright owner.

Devices sold by ams AG are covered by the warranty and patent indemnification provisions appearing in its Terms of Sale. ams AG makes no warranty, express, statutory, implied, or by description regarding the information set forth herein. ams AG reserves the right to change specifications and prices at any time and without notice. Therefore, prior to designing this product into a system, it is necessary to check with ams AG for current information. This product is intended for use in commercial applications. Applications requiring extended temperature range, unusual environmental requirements, or high reliability applications, such as military, medical life-support or life-sustaining equipment are specifically not recommended without additional processing by ams AG for each application. This Product is provided by ams "AS IS" and any express or implied warranties, including, but not limited to the implied warranties of merchantability and fitness for a particular purpose are disclaimed.

ams AG shall not be liable to recipient or any third party for any damages, including but not limited to personal injury, property damage, loss of profits, loss of use, interruption of business or indirect, special, incidental or consequential damages, of any kind, in connection with or arising out of the furnishing, performance or use of the technical data herein. No obligation or liability to recipient or any third party shall arise or flow out of ams AG rendering of technical or other services.

Document Status

Document Status	Product Status	Definition
Product Preview	Pre-Development	Information in this datasheet is based on product ideas in the planning phase of development. All specifications are design goals without any warranty and are subject to change without notice
Preliminary Datasheet	Pre-Production	Information in this datasheet is based on products in the design, validation or qualification phase of development. The performance and parameters shown in this document are preliminary without any warranty and are subject to change without notice
Datasheet	Production	Information in this datasheet is based on products in ramp-up to full production or full production which conform to specifications in accordance with the terms of ams AG standard warranty as given in the General Terms of Trade
Datasheet (discontinued)	Discontinued	Information in this datasheet is based on products which conform to specifications in accordance with the terms of ams AG standard warranty as given in the General Terms of Trade, but these products have been superseded and should not be used for new designs

Revision Information

Changes from 1-00 (2013-Aug) to current revision 1-01 (2014-May-06)	Page
Removed "Confidential" from footer	

Content Guide

1	General Description
1	Key Benefits & Features
2	Package Options
2	Applications
2	Block Diagram
3	Pin Assignment
4	Bare Die Pad Layout
6	Absolute Maximum Ratings
6	Electrical Discharge Sensitivity
6	Operating Conditions
7	Electrical Characteristics
9	Short Description
10	Supply Arrangement
10	Analog Front End (AFE)
10	Processing and Digital Control
11	Serial Interface (SPI)
11	Real-Time Clock (RTC)
11	Temperature Sensor
11	External Sensors
11	Analog to Digital Converter
11	External Sensor Interrupt
12	Data Protection
12	Shelf Life
12	Memory arrangement
13	System Description
13	Initializing the Chip
13	Power Modes
13	Ready Mode
13	Active Mode
13	Logging Mode
13	Interrupt Mode
13	Stand-by Mode
14	State Diagram
15	Data Protection
16	Data Log Functions
17	Limits Counter
18	Logging Timer
18	Delay Time
18	Analog to Digital Conversion
21	Temperature Conversion
21	Battery Voltage Conversion
22	Commands
25	Supported EPC Gen2 Commands
25	QueryREP - #01
25	ACK - #02
25	Query - #03
25	QueryAdjust - #04
25	Select - #05
25	NAK - #06
25	Req_RN - #07

25	Read - #08
26	Write - #09
26	Kill - #10
26	Lock - #11
26	Access - #12
26	BlockWrite - #13
26	BlockErase - #14
27	Cool-Log Custom Commands
27	Set Password - #15
27	Set Log Mode - #16
27	Set Log Limits - #17
27	Get Measurement Setup - #18
27	Set SFE Parameters - #19
27	Set Calibration Data - #20
27	End Log - #21
28	Start Log - #22
28	Get Log State - #23
28	Get Calibration Data - #24
28	Get Battery Level - #25
28	Set Shelf Life - #26
28	Initialize - #27
28	Get Sensor Value - #28
28	Open Area - #29
28	Access FIFO - #30

29 Custom Command Description

30	Set Password
30	Set Log Mode
31	Set Log Limits
31	Get Measurement Setup
33	Set SFE Parameters
33	Set Calibration Data
34	End Log
34	Start Log
35	Get Log State
36	Get Calibration Data
36	Get Battery Level
37	Set Shelf Life
37	Initialize
38	Get Sensor Value
39	Open Area
39	Access FIFO

41 Logging Formats

41	Dense Logging Form
42	Out-of-Limits Logging Form
43	Interrupt Logging Form
43	Storage Capacity

44 Storage Rule

44	Normal storage rule
44	Rolling storage rule

45 SPI Interface

49 SPI Direct Commands

50 FIFO

51 Alternate Pad Functions

51 Manual Log Start with Button

51 External Shelf Life Alarm Function

53 External Sensor Front-End (SFE)

53 SFE Interface

54 SFE Interface

56 External Sensor 1 Interface

59 External Sensor 2 Interface

60 External Sensor Interface Settings

61 External Sensor Interrupt

63 Calibration Bits**64 Shelf Life Calculation**

65 Shelf Life Sensor ID [1:0]

69 Memory Map Overview**77 Applications**77 Battery-Assisted Transponder – Temperature
Data Logger

77 Passive Transponder – Passive Temperature Sensor

78 Battery-Assisted Transponder with
External Microcontroller78 Battery-Assisted Transponder with Pushbutton for
Manual Delayed Log Start

79 Dense Mode Logging – First 8 Measurements

82 Package Drawings and Markings**83 RoHS Compliant & ams Green Statement****84 Ordering & Contact Information****85 Copyrights & Disclaimer**

X-ON Electronics

Largest Supplier of Electrical and Electronic Components

Click to view similar products for [RFID Transponder Tools](#) category:

Click to view products by [ams](#) manufacturer:

Other Similar products are found below :

[V700-A43 10M](#) [WF-SM-30](#) [V700-A44 20M](#) [V680-A81](#) [WS02-CFSC1-EV3](#) [V680-A60 5M](#) [V680-HAM91](#) [V680-A60 10M](#) [V700-A46 50M](#)
[ST25-TAG-BAG-U](#) [MIKROE-3644](#) [MIKROE-2395](#) [1482](#) [MIKROE-2462](#) [2800](#) [2802](#) [X-NUCLEO-NFC05A1](#) [359](#) [360](#) [361](#) [362](#) [363](#) [365](#)
[3781](#) [789](#) [884](#) [4032](#) [4033](#) [4034](#) [4043](#) [4429](#) [4701](#) [AS3980-QF_DK_ST](#) [AS3953-DK-TAGS](#) [ATARFID-EK1](#) [ATARFID-EK2](#) [EVB90109](#)
[MIKROE-3659](#) [MIKROE-3971](#) [MIKROE-4208](#) [MIKROE-1434](#) [MIKROE-1475](#) [MIKROE-1726](#) [MIKROE-262](#) [MIKROE-4309](#) [13429-6001](#)
[LXRFZZHAAA-028-KIT](#) [OM25180FDKM](#) [MOD-RFID125](#) [3S4YR-HSR3](#)