

- Converts Light Intensity to Output Voltage
- Monolithic Silicon IC Containing Photodiode, Operational Amplifier, and Feedback Components
- High Sensitivity
- Single Voltage Supply Operation (2.7 V to 5.5 V)
- Low Noise (200 μ Vrms Typ to 1 kHz)
- Rail-to-Rail Output
- High Power-Supply Rejection (35 dB at 1 kHz)
- Compact 3-Leaded Plastic Package
- RoHS Compliant (–LF Package Only)

PACKAGE S
SIDELOOKER
(FRONT VIEW)

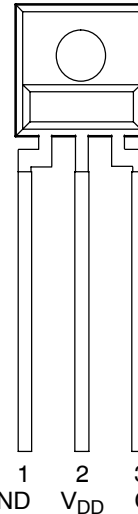

PACKAGE SM
SURFACE MOUNT
SIDELOOKER
(FRONT VIEW)

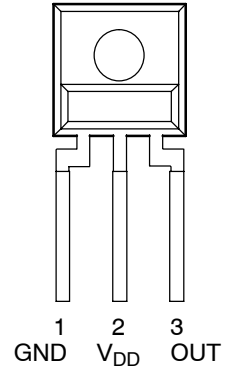

Description

The TSL257 is a high-sensitivity low-noise light-to-voltage optical converter that combines a photodiode and a transimpedance amplifier on a single monolithic CMOS integrated circuit. Output voltage is directly proportional to light intensity (irradiance) on the photodiode. The TSL257 has a transimpedance gain of 320 M Ω . The device has improved offset voltage stability and low power consumption and is supplied in a 3-lead clear plastic sidelooker package with an integral lens. When supplied in the lead (Pb) free package, the device is RoHS compliant.

Functional Block Diagram

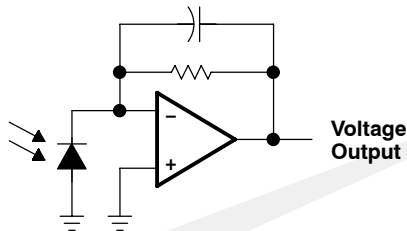

Available Options

DEVICE	T _A	PACKAGE - LEADS	PACKAGE DESIGNATOR	ORDERING NUMBER
TSL257	0°C to 70°C	3-lead Sidelooker	S	TSL257
TSL257	0°C to 70°C	3-lead Sidelooker — Lead (Pb) Free	S	TSL257-LF
TSL257	0°C to 70°C	3-lead Surface-Mount Sidelooker — Lead (Pb) Free	SM	TSL257SM-LF

Terminal Functions

TERMINAL NAME	NO.	DESCRIPTION
GND	1	Ground (substrate). All voltages are referenced to GND.
OUT	3	Output voltage
V _{DD}	2	Supply voltage

TSL257 HIGH-SENSITIVITY LIGHT-TO-VOLTAGE CONVERTER

TAOS023E – SEPTEMBER 2007

Absolute Maximum Ratings over operating free-air temperature range (unless otherwise noted)[†]

Supply voltage, V_{DD} (see Note 1)	6 V
Output current, I_O	± 10 mA
Duration of short-circuit current at (or below) 25°C	5 s
Operating free-air temperature range, T_A	-25°C to 85°C
Storage temperature range, T_{stg}	-25°C to 85°C
Lead temperature 1,6 mm (1/16 inch) from case for 10 seconds (S Package)	260°C
Reflow solder, in accordance with J-STD-020C or J-STD-020D (SM Package)	260°C

[†] Stresses beyond those listed under “absolute maximum ratings” may cause permanent damage to the device. These are stress ratings only, and functional operation of the device at these or any other conditions beyond those indicated under “recommended operating conditions” is not implied. Exposure to absolute-maximum-rated conditions for extended periods may affect device reliability.

NOTE 1: All voltages are with respect to GND.

Recommended Operating Conditions

	MIN	MAX	UNIT
Supply voltage, V_{DD}	2.7	5.5	V
Operating free-air temperature, T_A	0	70	°C

Electrical Characteristics at $V_{DD} = 5$ V, $T_A = 25^\circ\text{C}$, $\lambda_p = 470$ nm, $R_L = 10$ k Ω (unless otherwise noted) (see Notes 2 and 3)

PARAMETER		TEST CONDITIONS	MIN	TYP	MAX	UNIT
V_D	Dark voltage	$E_e = 0$	0		15	mV
V_{OM}	Maximum output voltage swing	$V_{DD} = 4.5$ V, No Load		4.49		V
		$V_{DD} = 4.5$ V, $R_L = 10$ k Ω	4	4.2		
V_O	Output voltage	$E_e = 1.54$ $\mu\text{W}/\text{cm}^2$, $\lambda_p = 470$ nm, Note 5	1.6	2	2.4	V
α_{VD}	Temperature coefficient of dark voltage (V_D)	$T_A = 0^\circ\text{C}$ to 70°C		-15		$\mu\text{V}/^\circ\text{C}$
N_e	Irradiance responsivity	$\lambda_p = 428$ nm, see Notes 4 and 8		1.18		V/ $(\mu\text{W}/\text{cm}^2)$
		$\lambda_p = 470$ nm, see Notes 5 and 8		1.30		
		$\lambda_p = 565$ nm, see Notes 6 and 8		1.58		
		$\lambda_p = 645$ nm, see Notes 7 and 8		1.68		
PSRR	Power supply rejection ratio	$f_{ac} = 100$ Hz, see Note 9		55		dB
		$f_{ac} = 1$ kHz, see Note 9		35		dB
I_{DD}	Supply current	$E_e = 1.54$ $\mu\text{W}/\text{cm}^2$, $\lambda_p = 470$ nm, Note 5		1.9	3.5	mA

- NOTES:
- Measured with $R_L = 10$ k Ω between output and ground.
 - Optical measurements are made using small-angle incident radiation from a light-emitting diode (LED) optical source.
 - The input irradiance is supplied by a GaN/SiC light-emitting diode with the following characteristics: peak wavelength $\lambda_p = 428$ nm, spectral halfwidth $\Delta\lambda_{1/2} = 65$ nm.
 - The input irradiance is supplied by an InGaIn light-emitting diode with the following characteristics: peak wavelength $\lambda_p = 470$ nm, spectral halfwidth $\Delta\lambda_{1/2} = 35$ nm.
 - The input irradiance is supplied by a GaP light-emitting diode with the following characteristics: peak wavelength $\lambda_p = 565$ nm, spectral halfwidth $\Delta\lambda_{1/2} = 28$ nm.
 - The input irradiance is supplied by an AlGaAs light-emitting diode with the following characteristics: peak wavelength $\lambda_p = 645$ nm, spectral halfwidth $\Delta\lambda_{1/2} = 25$ nm.
 - Irradiance responsivity is characterized over the range $V_O = 0.1$ V to 4.5 V. The best-fit straight line of Output Voltage V_O versus Irradiance E_e over this range will typically have a positive extrapolated V_O value for $E_e = 0$.
 - Power supply rejection ratio PSRR is defined as $20 \log (\Delta V_{DD}(f)/\Delta V_O(f))$ with $V_{DD}(f = 0) = 5$ V and $V_O(f = 0) = 2$ V.

Switching Characteristics at $V_{DD} = 5\text{ V}$, $T_A = 25^\circ\text{C}$, $\lambda_p = 470\text{ nm}$, $R_L = 10\text{ k}\Omega$ (unless otherwise noted)

PARAMETER	TEST CONDITIONS	MIN	TYP	MAX	UNIT
t_r Output pulse rise time, 10% to 90% of final value	See Note 10 and Figure 1		160	250	μs
t_f Output pulse fall time, 10% to 90% of final value	See Note 10 and Figure 1		150	250	μs
t_s Output settling time to 1% of final value	See Note 10 and Figure 1		330		μs
Integrated noise voltage	$f = \text{dc to } 1\text{ kHz}$ $E_e = 0$		200		μVrms
V_n Output noise voltage, rms	$f = 10\text{ Hz}$ $E_e = 0$		6		$\mu\text{V}/\sqrt{\text{Hz}}$ rms
	$f = 100\text{ Hz}$ $E_e = 0$		6		
	$f = 1\text{ kHz}$ $E_e = 0$		7		

NOTE 10: Switching characteristics apply over the range $V_O = 0.1\text{ V}$ to 4.5 V .

PARAMETER MEASUREMENT INFORMATION

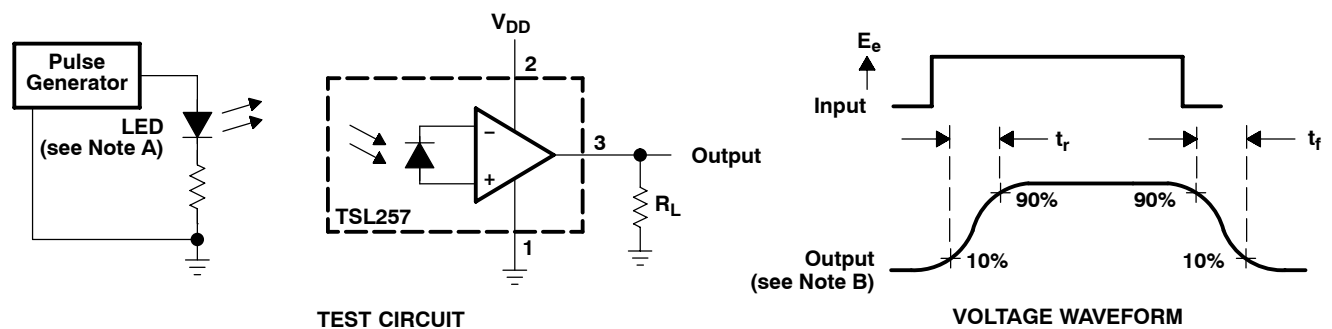

- NOTES: A. The input irradiance is supplied by a pulsed InGaN light-emitting diode with the following characteristics: $\lambda_p = 470\text{ nm}$, $t_r < 1\text{ }\mu\text{s}$, $t_f < 1\text{ }\mu\text{s}$.
- B. The output waveform is monitored on an oscilloscope with the following characteristics: $t_r < 100\text{ ns}$, $Z_i \geq 1\text{ M}\Omega$, $C_i \leq 20\text{ pF}$.

Figure 1. Switching Times

TSL257
HIGH-SENSITIVITY
LIGHT-TO-VOLTAGE CONVERTER

TAOS023E – SEPTEMBER 2007

TYPICAL CHARACTERISTICS

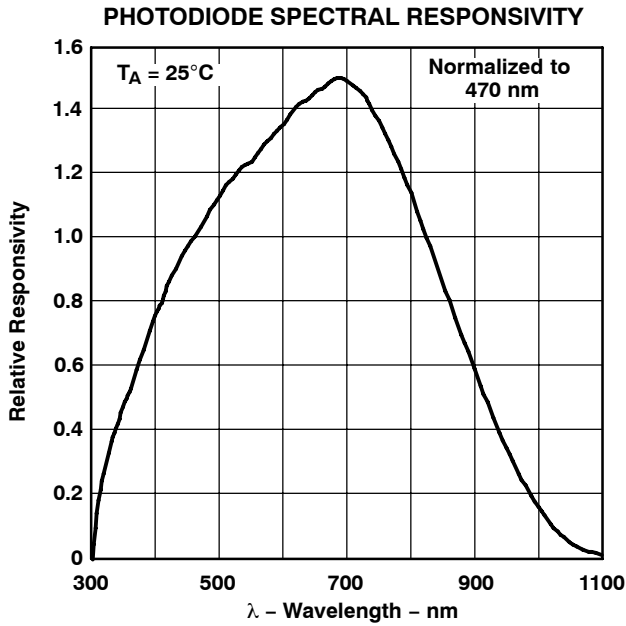

Figure 2

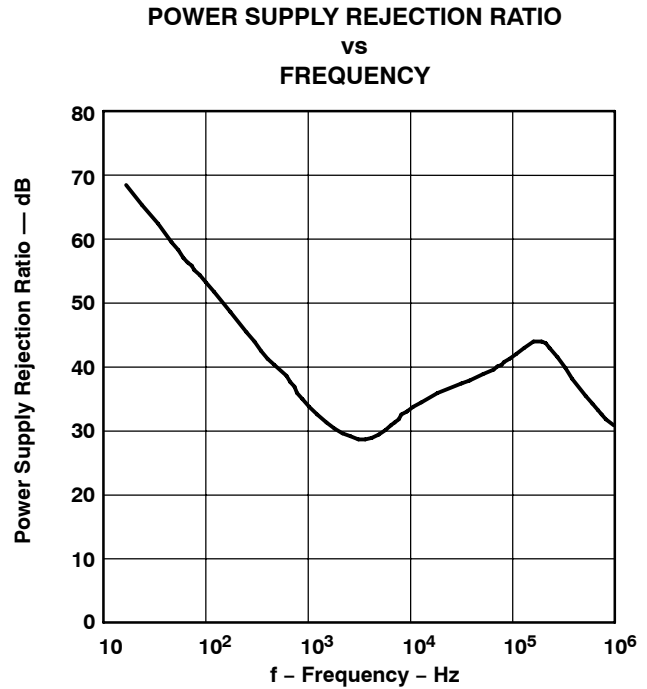

Figure 3

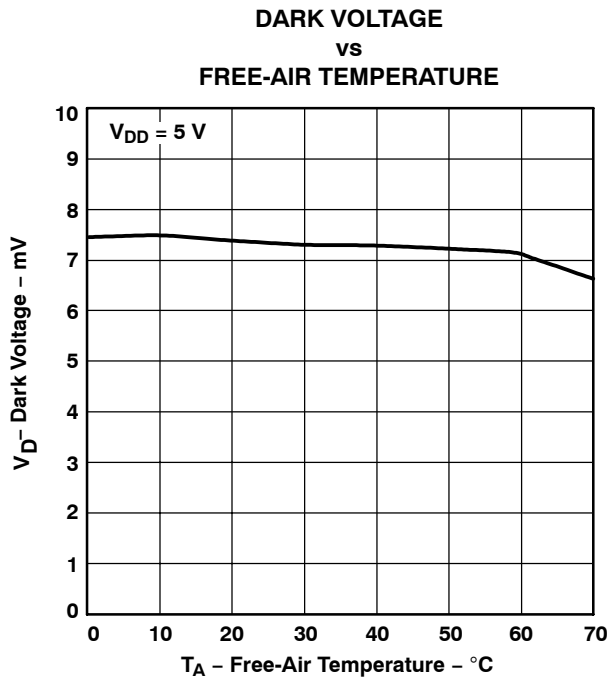

Figure 4

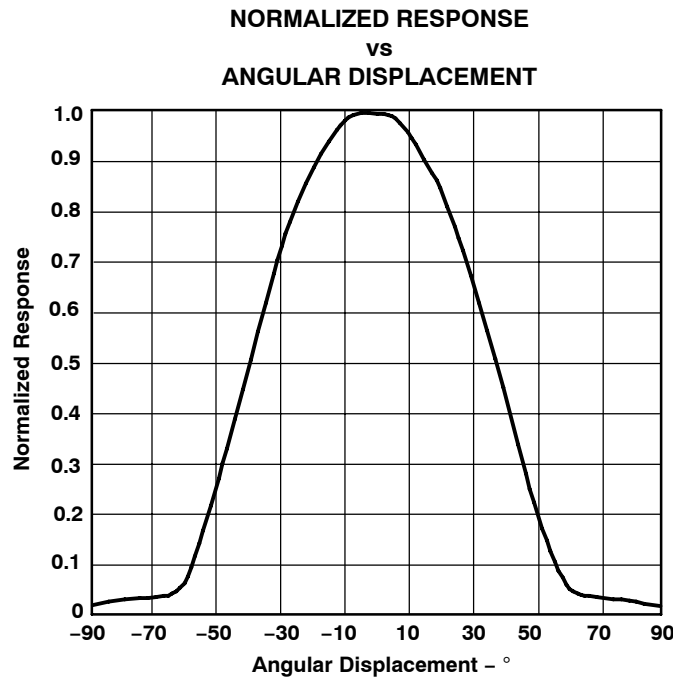
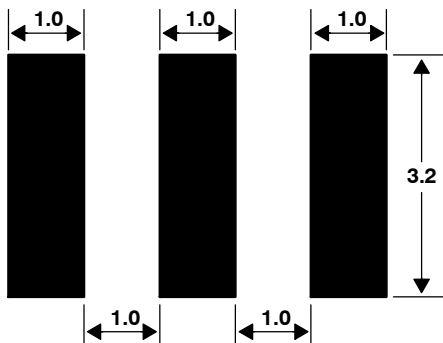

Figure 5

APPLICATION INFORMATION

PCB Pad Layout

Suggested PCB pad layout guidelines for the SM surface mount package are shown in Figure 6.



- NOTES: A. All linear dimensions are in millimeters.
B. This drawing is subject to change without notice.

Figure 6. Suggested SM Package PCB Layout

TSL257
HIGH-SENSITIVITY
LIGHT-TO-VOLTAGE CONVERTER

TAOS023E – SEPTEMBER 2007

MECHANICAL DATA

The device is supplied in a clear plastic three-lead sidelooker through-hole package (S).

PACKAGE S

PLASTIC SINGLE-IN-LINE SIDE-LOOKER PACKAGE

TOP VIEW

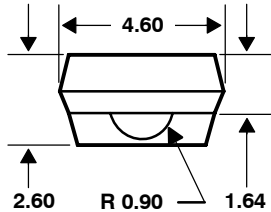

FRONT VIEW

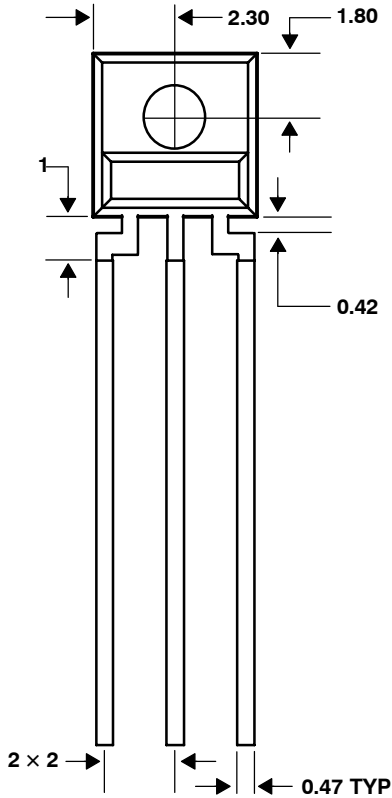

SIDE VIEW

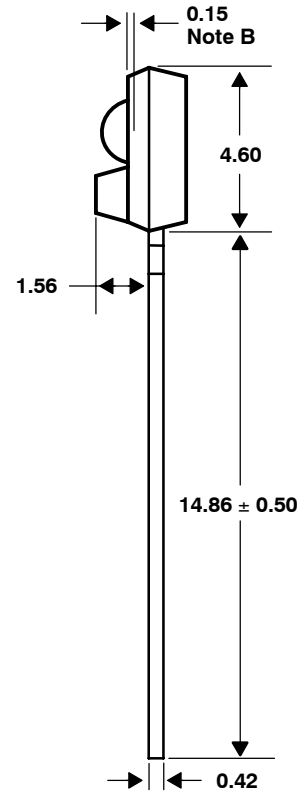

Lead Free Available

- NOTES: A. All linear dimensions are in millimeters; tolerance is ± 0.25 mm unless otherwise stated.
 B. Dimension is to center of lens arc, which is located below the package face.
 C. The integrated photodiode active area is round with a typical diameter of 0.75 mm and is typically located in the center of the lens and 0.97 mm below the top of the lens surface.
 D. Index of refraction of clear plastic is 1.55.
 E. Lead finish for TSL257: solder dipped, 63% Sn/37% Pb. Lead finish for TSL257-LF: solder dipped, 100% Sn.
 F. This drawing is subject to change without notice.

Figure 7. Package S — Single-In-Line Side-Looker Package Configuration

MECHANICAL DATA

PACKAGE SM

PLASTIC SURFACE MOUNT SIDE-LOOKER PACKAGE

TOP VIEW

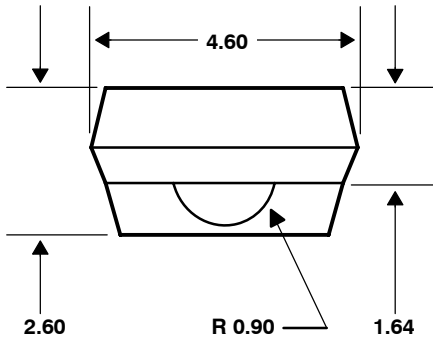

FRONT VIEW

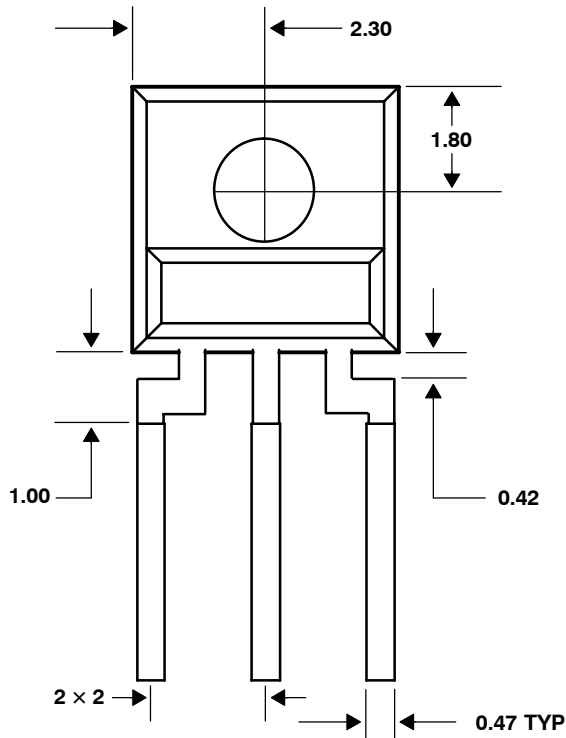

SIDE VIEW

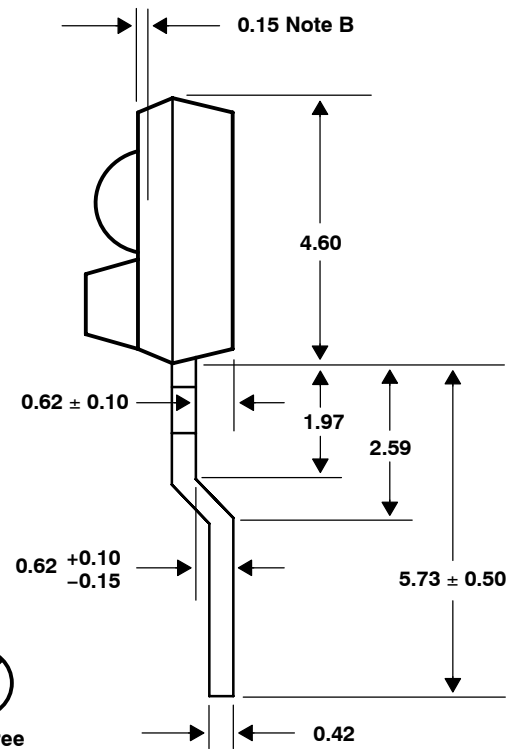

- NOTES: A. All linear dimensions are in millimeters; tolerance is ± 0.25 mm unless otherwise stated.
 B. Dimension is to center of lens arc, which is located below the package face.
 C. The integrated photodiode active area is typically located in the center of the lens and 0.97 mm below the top of the lens surface.
 D. Index of refraction of clear plastic is 1.55.
 E. Lead finish for TSL257SM-LF: solder dipped, 100% Sn.
 F. This drawing is subject to change without notice.

Figure 8. Package SM — Surface Mount Side-Looker Package Configuration

TSL257 HIGH-SENSITIVITY LIGHT-TO-VOLTAGE CONVERTER

TAOS023E – SEPTEMBER 2007

PRODUCTION DATA — information in this document is current at publication date. Products conform to specifications in accordance with the terms of Texas Advanced Optoelectronic Solutions, Inc. standard warranty. Production processing does not necessarily include testing of all parameters.

LEAD-FREE (Pb-FREE) and GREEN STATEMENT

Pb-Free (RoHS) TAOS' terms *Lead-Free* or *Pb-Free* mean semiconductor products that are compatible with the current RoHS requirements for all 6 substances, including the requirement that lead not exceed 0.1% by weight in homogeneous materials. Where designed to be soldered at high temperatures, TAOS Pb-Free products are suitable for use in specified lead-free processes.

Green (RoHS & no Sb/Br) TAOS defines *Green* to mean Pb-Free (RoHS compatible), and free of Bromine (Br) and Antimony (Sb) based flame retardants (Br or Sb do not exceed 0.1% by weight in homogeneous material).

Important Information and Disclaimer The information provided in this statement represents TAOS' knowledge and belief as of the date that it is provided. TAOS bases its knowledge and belief on information provided by third parties, and makes no representation or warranty as to the accuracy of such information. Efforts are underway to better integrate information from third parties. TAOS has taken and continues to take reasonable steps to provide representative and accurate information but may not have conducted destructive testing or chemical analysis on incoming materials and chemicals. TAOS and TAOS suppliers consider certain information to be proprietary, and thus CAS numbers and other limited information may not be available for release.

NOTICE

Texas Advanced Optoelectronic Solutions, Inc. (TAOS) reserves the right to make changes to the products contained in this document to improve performance or for any other purpose, or to discontinue them without notice. Customers are advised to contact TAOS to obtain the latest product information before placing orders or designing TAOS products into systems.

TAOS assumes no responsibility for the use of any products or circuits described in this document or customer product design, conveys no license, either expressed or implied, under any patent or other right, and makes no representation that the circuits are free of patent infringement. TAOS further makes no claim as to the suitability of its products for any particular purpose, nor does TAOS assume any liability arising out of the use of any product or circuit, and specifically disclaims any and all liability, including without limitation consequential or incidental damages.

TEXAS ADVANCED OPTOELECTRONIC SOLUTIONS, INC. PRODUCTS ARE NOT DESIGNED OR INTENDED FOR USE IN CRITICAL APPLICATIONS IN WHICH THE FAILURE OR MALFUNCTION OF THE TAOS PRODUCT MAY RESULT IN PERSONAL INJURY OR DEATH. USE OF TAOS PRODUCTS IN LIFE SUPPORT SYSTEMS IS EXPRESSLY UNAUTHORIZED AND ANY SUCH USE BY A CUSTOMER IS COMPLETELY AT THE CUSTOMER'S RISK.

LUMENOLOGY, TAOS, the TAOS logo, and Texas Advanced Optoelectronic Solutions are registered trademarks of Texas Advanced Optoelectronic Solutions Incorporated.

X-ON Electronics

Largest Supplier of Electrical and Electronic Components

Click to view similar products for [Light To Frequency & Light To Voltage](#) category:

Click to view products by [ams](#) manufacturer:

Other Similar products are found below :

[OPT101PG4](#) [OPT301M](#)