

TSL2672

Digital Proximity Detector

General Description

The TSL2672 family of devices provides proximity detection when coupled with an external IR LED. The devices incorporate a constant-current LED sink driver to pulse the external IR LED and achieve very low average power consumption using the low-power wait state with programmable wait time between proximity measurements. In addition, the devices are register-set and pin-compatible with the TSL2671 series and include a number of new and improved features, such as improved signal-to-noise and measurement accuracy. A proximity offset register allows compensation for optical system crosstalk between the IR LED and the sensor. To prevent false measurements, a proximity saturation bit indicates that the internal analog circuitry saturated. Interrupts have been enhanced with the addition of a sleep-after-interrupt feature that also allows for single-cycle operation.

Ordering Information and Content Guide appear at end of datasheet.

Key Benefits & Features

The benefits and features of TSL2672, Digital Proximity Detector are listed below:

Figure 1:
Added Value Of Using TSL2672

Benefits	Features
<ul style="list-style-type: none"> Enables Operation in IR Light Environments 	<ul style="list-style-type: none"> Patented Dual-Diode Architecture
<ul style="list-style-type: none"> Eliminates IR LED System Cross Talk 	<ul style="list-style-type: none"> Programmable Proximity Offset Adjustment
<ul style="list-style-type: none"> Prevents False Proximity Detection in Bright Light 	<ul style="list-style-type: none"> Proximity Saturation Indicator Bit
<ul style="list-style-type: none"> Allows Multiple Power-level Selection without External Passives 	<ul style="list-style-type: none"> Programmable LED Drive Current

- Proximity Detection with an Integrated LED Driver in a Single Device
- Register Set- and Pin-Compatible with the TSL2x71 Series
- Proximity Detection
 - Reduced Proximity Count Variation
 - Programmable Offset Control Register
 - Saturation Indicator
 - Programmable Analog Gain and Integration Time
 - Current Sink Driver for External IR LED
 - 16,000:1 Dynamic Range

- Maskable Proximity Interrupt
 - Programmable Upper and Lower Thresholds with Persistence Filter
- Power Management
 - Low Power 2.2 μ A Sleep State with User-Selectable Sleep-After-Interrupt Mode
 - 90 μ A Wait State with Programmable Wait Time from 2.7 ms to > 8 seconds
- I²C Fast Mode Compatible Interface
 - Data Rates up to 400 kbit/s
 - Input Voltage Levels Compatible with VDD or 1.8-V Bus
- Small 2 mm x 2 mm ODFN Package

Applications

TSL2672, Digital Proximity Detector is ideal for:

- Mobile Handset Touchscreen Control and Automatic Speakerphone Enable
- Mechanical Switch Replacement
- Printer Paper Alignment

End Products and Market Segments

- Mobile Handsets, Tablets, Laptops, and HDTVs
- White Goods
- Toys
- Digital Signage
- Printers

Functional Block Diagram

The functional blocks of this device are shown below:

Figure 2:
TSL2672 Block Diagram

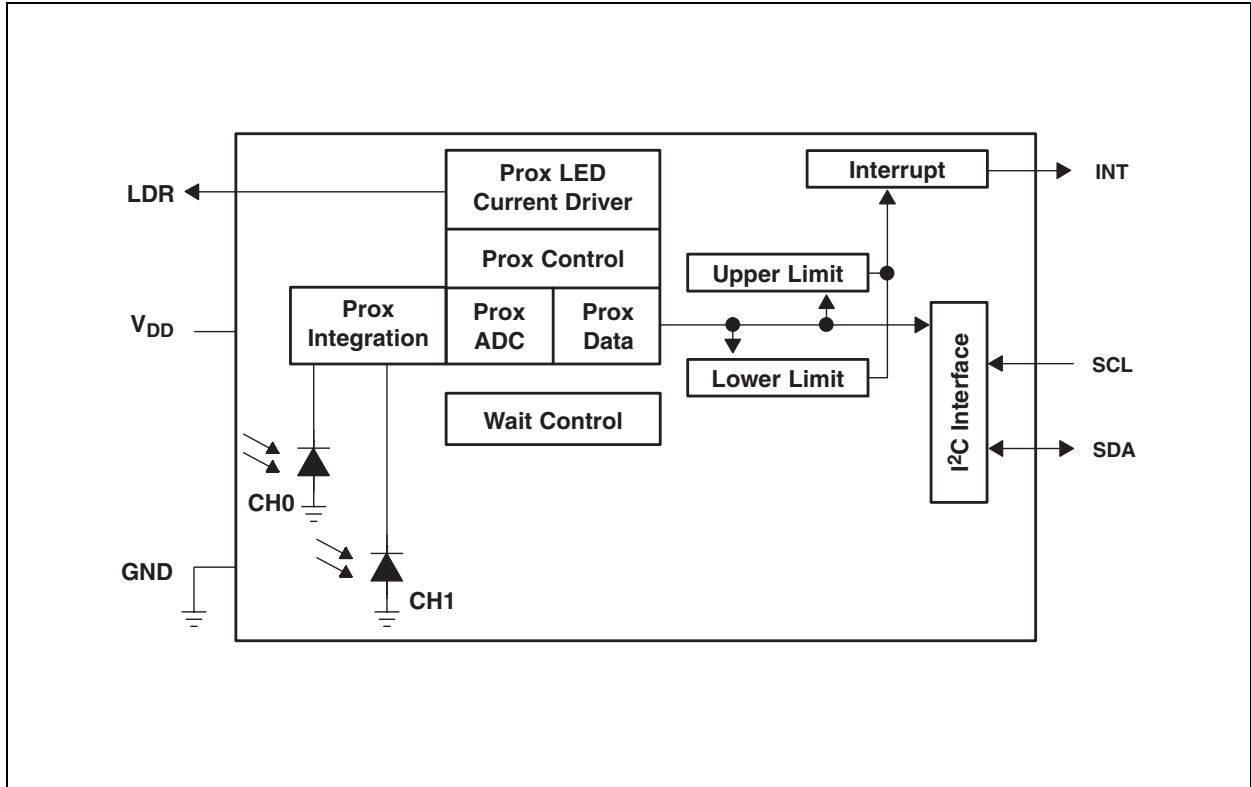

Pin Assignments

Figure 3:
Package FN Dual Flat No-Lead (Top View)

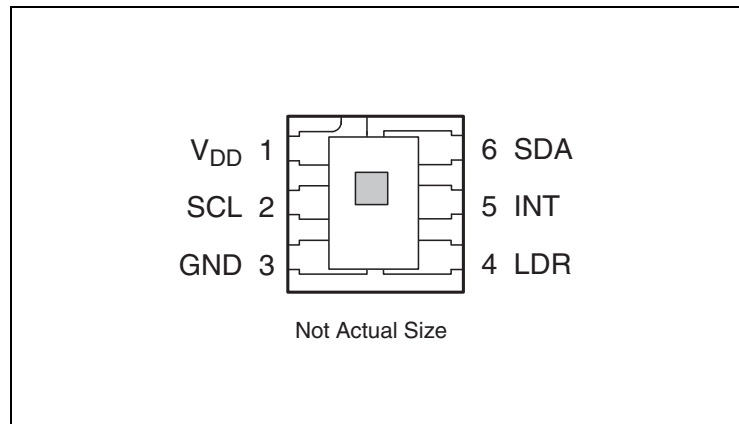

Figure 4:
Terminal Functions

Terminal		Type	Description
Name	No		
GND	3		Power supply ground. All voltages are referenced to GND.
INT	5	O	Interrupt — open drain (active low).
LDR	4	O	LED driver for proximity emitter — open drain.
SCL	2	I	I ² C serial clock input terminal — clock signal for I ² C serial data.
SDA	6	I/O	I ² C serial data I/O terminal — serial data I/O for I ² C.
V _{DD}	1		Supply voltage.

Detailed Description

Proximity detection requires only a single external LED. This external LED is driven by an internal LED current driver, which pulses the LED with current for approximately 7 microseconds. The number of pulses, from 1 to 255, and the current level, from 1.9 mA to 120 mA, can be programmed and together provide a 16,000:1 contiguous dynamic range. Because the driver is a constant current sink, no external current limiting resistor is required to protect the LED.

In addition to the internal LED current driver, the TSL2672 proximity detector provides ON-chip photodiodes, oscillator, integrating amplifier, ADC, state machine controller, programmable interrupt and I²C interface to provide a complete proximity detection solution.

Each device has two photodiodes; a channel 0 photodiode (CH0), which is responsive to both visible and infrared light, and a channel 1 photodiode (CH1), which is primarily responsive to only infrared light. The user selects the appropriate diode for their application.

The integrating amplifier and ADC converts the selected photodiode current into a digital value providing up to 16 bits of resolution. Upon completion of a proximity conversion cycle, the result is transferred to the proximity data registers where it is available to be read.

Communication with the device is accomplished over a fast (up to 400 kHz), two-wire I²C serial bus for easy connection to a microcontroller or embedded controller. The digital output of the device is inherently more noise-immune when compared to an analog interface.

The device provides a separate pin for level-style interrupts to simplify and improve system efficiency by eliminating the need to poll for proximity data. When interrupts are enabled, an interrupt is generated when the proximity data either exceeds an upper threshold or is less than a lower threshold. Once generated, the interrupt remains asserted until cleared by the controlling firmware. In addition, a programmable interrupt persistence filter allows the user to determine the number of consecutive out-of-range measurements necessary to trigger an interrupt.

Absolute Maximum Ratings

Stresses beyond those listed under [Absolute Maximum Ratings](#) may cause permanent damage to the device. These are stress ratings only, and functional operation of the device at these or any other conditions beyond those indicated under [Recommended Operating Conditions](#) is not implied. Exposure to absolute-maximum-rated conditions for extended periods may affect device reliability.

Figure 5:
Absolute Maximum Ratings Over Operating Free-Air Temperature Range (unless otherwise noted)

Symbol	Parameter	Min	Max	Units
$V_{DD}^{(1)}$	Supply voltage		3.8	V
	Input terminal voltage	-0.5	3.8	V
	Output terminal voltage (except LDR)	-0.5	3.8	V
	Output terminal voltage (LDR)		5	V
	Output terminal current (except LDR)	-1	20	mA
T_{stg}	Storage temperature range	-40	85	°C
ESD_{HBM}	ESD tolerance, human body model	±2000		V

Note(s):

- All voltages are with respect to GND.

Figure 6:
Recommended Operating Conditions

Symbol	Parameter	Conditions	Min	Nom	Max	Unit
V_{DD}	Supply voltage	(TSL26721 & TSL26725) ($I^2C V_{bus} = V_{DD}$)	2.4	3	3.6	V
V_{DD}	Supply voltage	(TSL26723 & TSL26727) ($I^2C V_{bus} = 1.8V$)	2.7	3	3.6	V
V_{LDR}	LED driver voltage	LDR pulse ON	0		3.6	V
		LDR pulse OFF	0		4.8	
T_A	Operating free-air temperature		-30		70	°C

Figure 7:
Operating Characteristics; $V_{DD} = 3\text{ V}$, $T_A = 25^\circ\text{C}$ (unless otherwise noted)

Symbol	Parameter	Test Conditions	Min	Typ	Max	Unit
I_{DD}	Supply current	Active — LDR pulse OFF		200	250	μA
		Wait state		90		
		Sleep state - no I ² C activity		2.2	4	
V_{OL}	INT, SDA output low voltage	3 mA sink current	0		0.4	V
		6 mA sink current	0		0.6	
I_{LEAK}	Leakage current, SDA, SCL, INT pins		-5		5	μA
I_{LEAK}	Leakage current, LDR pin		-5		5	μA
V_{IH}	SCL, SDA input high voltage	TSL26721, TSL26725	$0.7V_{DD}$			V
		TSL26723, TSL26727	1.25			
V_{IL}	SCL, SDA input low voltage	TSL26721, TSL26725			$0.3V_{DD}$	V
		TSL26723, TSL26727			0.54	

Figure 8:
Proximity Characteristics; $V_{DD} = 3\text{ V}$, $T_A = 25^\circ\text{C}$, PGAIN = 1', PEN = 1 (unless otherwise noted)

Parameter	Test Conditions	Min	Typ	Max	Unit	
I_{DD} Supply current	LDR pulse ON		3		mA	
ADC conversion time step size	PTIME = 0xFF	2.58	2.73	2.9	ms	
ADC number of integration steps ⁽¹⁾		1		256	steps	
ADC counts per step ⁽¹⁾	PTIME = 0xFF	0		1023	counts	
ADC count value	$\lambda_p = 850\text{ nm}$, $E_e = 263.4\mu\text{W}/\text{cm}^2$, PTIME = 0xFB, PPULSE = 4	CH0 diode	1500	2000	2500	counts
		CH1 diode	900	1200	1500	
ADC output responsivity	$\lambda_p = 850\text{ nm}$, PTIME = 0xFB, PPULSE = 1	CH0 diode		1.90		counts/ $\mu\text{W}/\text{cm}^2$
		CH1 diode		1.14		

Parameter	Test Conditions		Min	Typ	Max	Unit
Gain scaling, relative to 1x gain setting	PGAIN = 2x			2		x
	PGAIN = 4x			4		
	PGAIN = 8x			8		
Noise ^{(1) (2) (3)}	$E_e = 0$, PTIME = 0x, PPULSE = 4 ⁽⁶⁾	CH0 diode		0.5		%FS
		CH1 diode		0.5		
LED pulse count ⁽¹⁾			0		255	pulses
LED pulse period				16.0		μ s
LED pulse width — LED ON time				7.3		μ s
LED drive current	I_{SINK} sink current @ 1.6 V, LDR pin	120 mA: PDRIVE = 0 & PDL = 0	87	116	145	mA
		60 mA: PDRIVE = 1 & PDL = 0		58		
		30 mA: PDRIVE = 2 & PDL = 0		29		
		15 mA: PDRIVE = 3 & PDL = 0		14.5		
		15 mA: PDRIVE = 0 & PDL = 1		12.9		
		7.5 mA: PDRIVE = 1 & PDL = 1		6.4		
		3.8 mA: PDRIVE = 2 & PDL = 1		3.2		
		1.9 mA: PDRIVE = 3 & PDL = 1		1.6		
Maximum operating distance ⁽¹⁾⁽⁴⁾⁽⁵⁾	PDRIVE = 0 and PDL = 0 (116 mA), PPULSE = 64 Emitter: $\lambda_p = 850$ nm, 20° half angle, and 60 mW/sr Object: 16 × 20-inch, 90% reflective Kodak Gray Card (white surface) Optics: Open view (no glass, no optical attenuation)			18		inches

Note(s):

- Parameter is ensured by design or characterization and is not tested.
- Proximity noise is defined as one standard deviation of 600 samples.
- Proximity noise typically increases as \sqrt{PPULSE}
- Greater operating distances are achievable with appropriate optical system design considerations. See available **ams** application notes for additional information.
- Maximum operating distance is dependent upon emitter and the reflective properties of the object's surface.
- Proximity noise test was done using the following circuit:

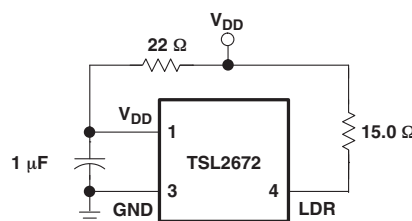

Figure 9:
Wait Characteristics; $V_{DD} = 3\text{ V}$, $T_A = 25^\circ\text{C}$, $WEN = 1$ (unless otherwise noted)

Parameter	Test Conditions	Channel	Min	Typ	Max	Unit
Wait step size	WTIME = 0xFF		2.58	2.73	2.9	ms
Wait number of integration steps ⁽¹⁾			1		256	steps

Note(s):

1. Parameter ensured by design and is not tested.

Figure 10:
AC Electrical Characteristics; $V_{DD} = 3\text{ V}$, $T_A = 25^\circ\text{C}$, (unless otherwise noted)

Symbol	Parameter ⁽¹⁾	Test Conditions	Min	Typ	Max	Unit
$f_{(SCL)}$	Clock frequency (I ² C only)		0		400	kHz
$t_{(BUF)}$	Bus free time between start and stop condition		1.3			μs
$t_{(HDSTA)}$	Hold time after (repeated) start condition. After this period, the first clock is generated.		0.6			μs
$t_{(SUSTA)}$	Repeated start condition setup time		0.6			μs
$t_{(SUSTO)}$	Stop condition setup time		0.6			μs
$t_{(HDDAT)}$	Data hold time		0			μs
$t_{(SUDAT)}$	Data setup time		100			ns
$t_{(LOW)}$	SCL clock low period		1.3			μs
$t_{(HIGH)}$	SCL clock high period		0.6			μs
t_F	Clock/data fall time				300	ns
t_R	Clock/data rise time				300	ns
C_i	Input pin capacitance				10	pF

Note(s):

1. Specified by design and characterization; not production tested.

Parameter Measurement Information

Figure 11:
Timing Diagrams

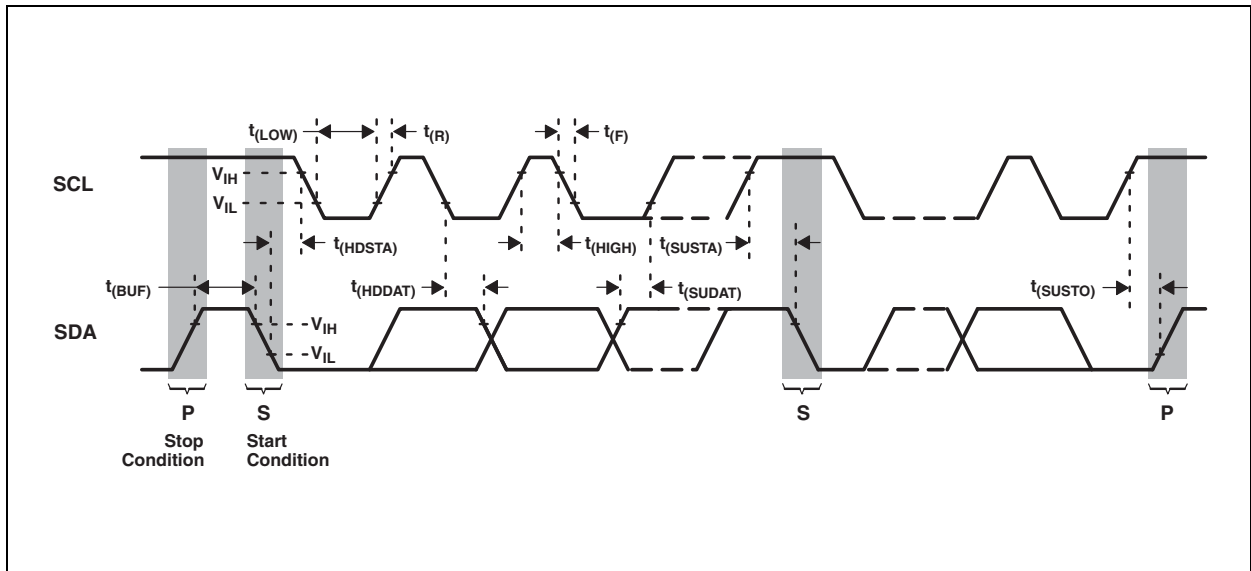

Typical Characteristics

Figure 12:
Spectral Responsivity

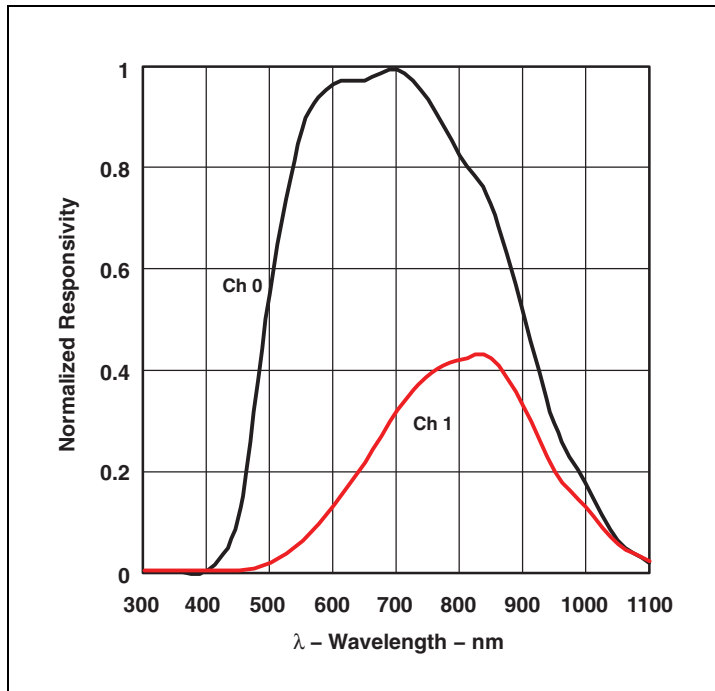

Figure 13:
Normalized Responsivity vs. Angular Displacement

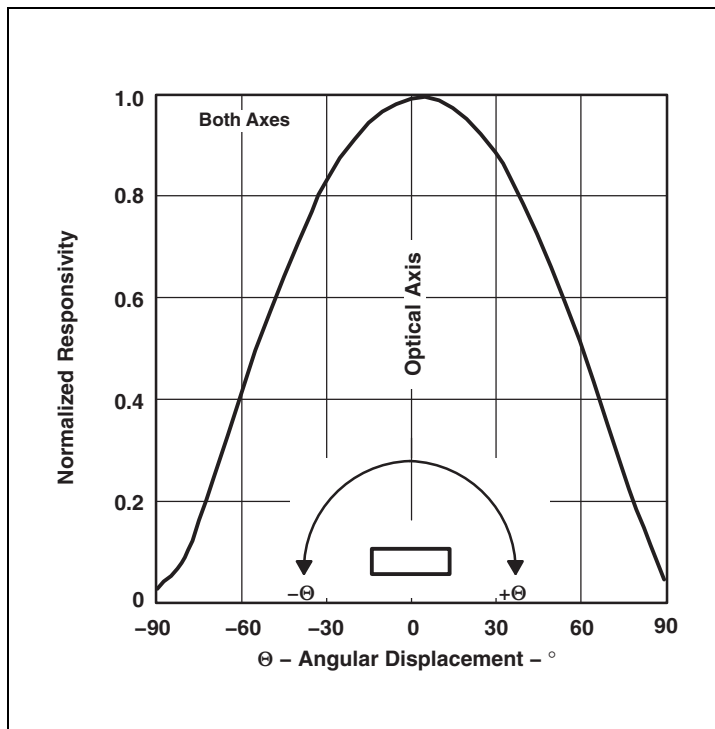

Figure 14:
Typical LDR Current vs. Voltage

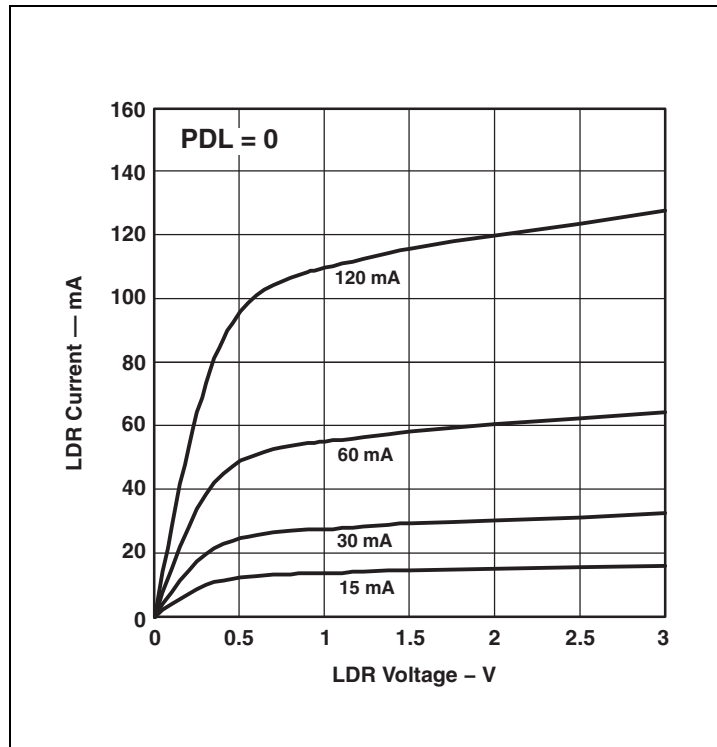

Figure 15:
Typical LDR Current vs. Voltage

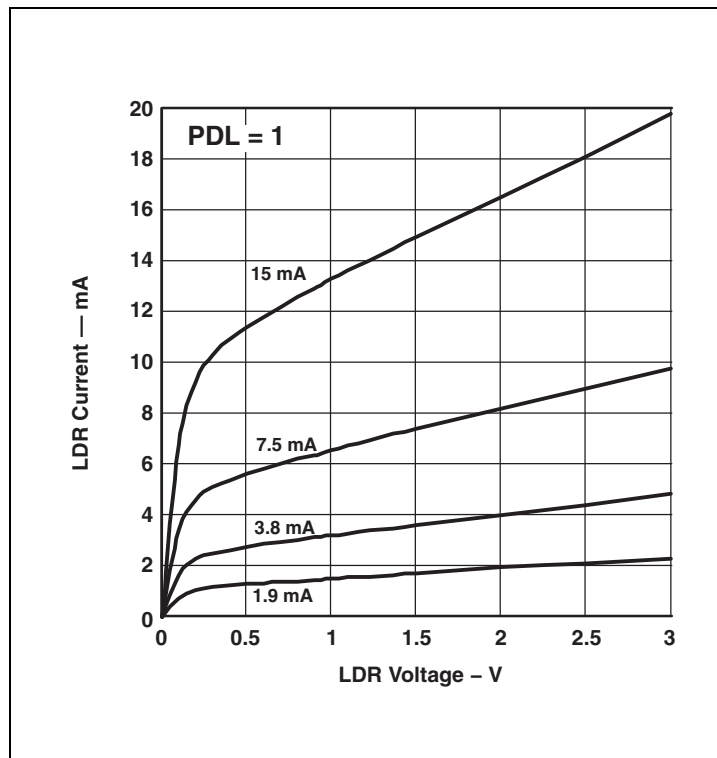

Figure 16:
Response to White LED vs. Temperature

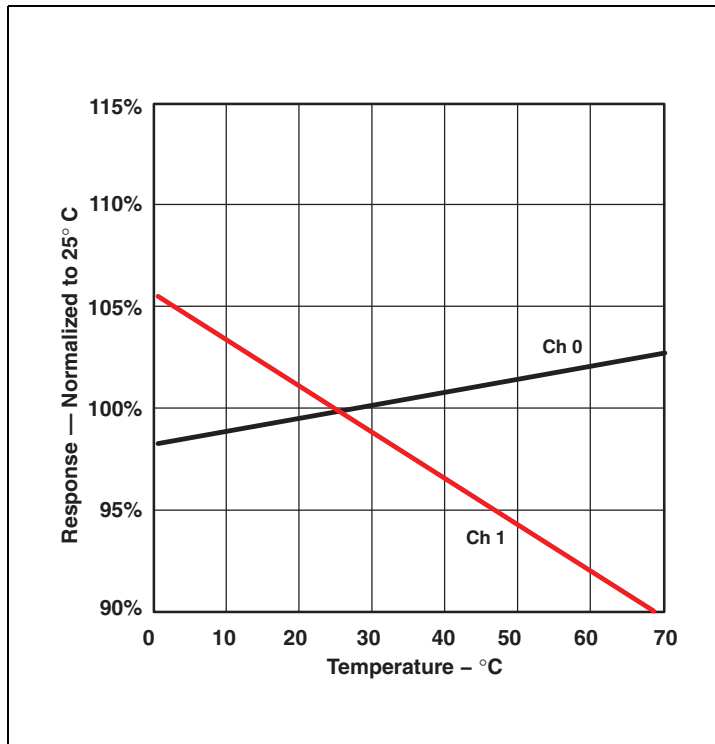

Figure 17:
Response to IR (850 nm) LED vs. Temperature

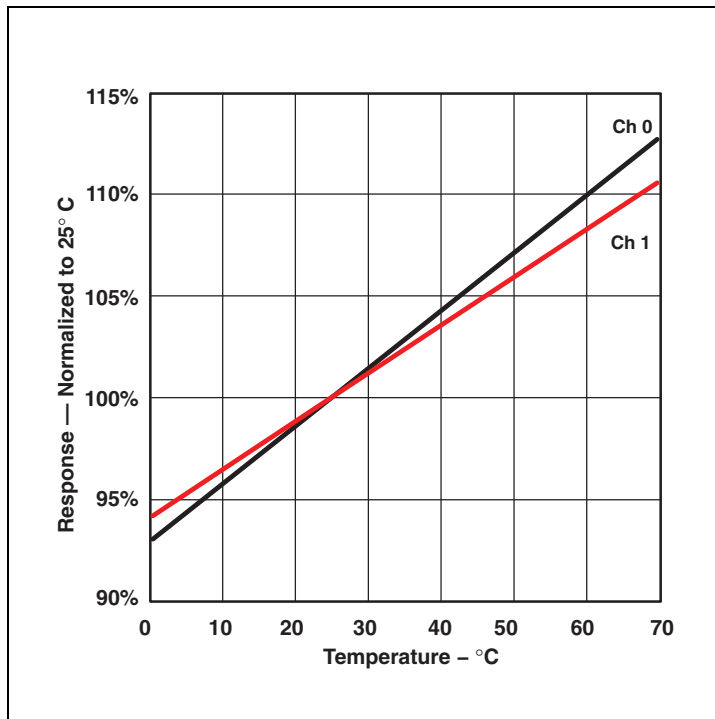
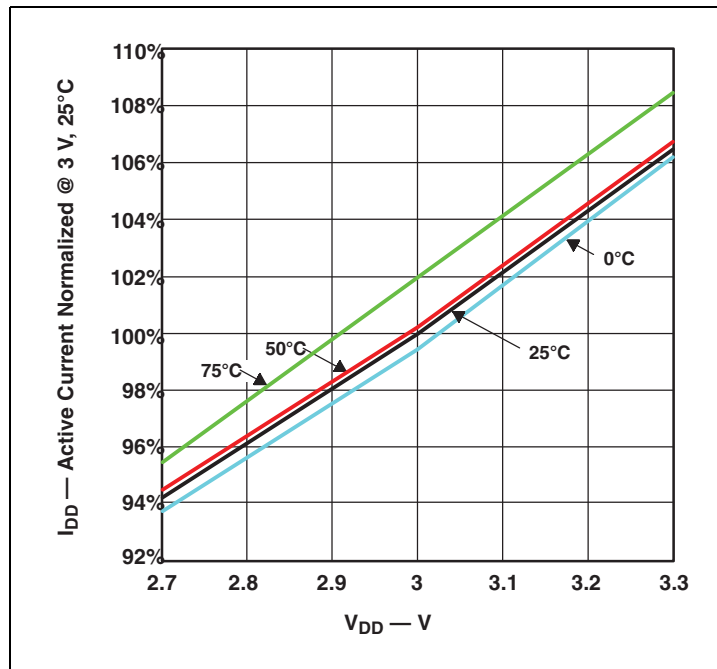

Figure 18:
Normalized I_{DD} vs. V_{DD} and Temperature



Principles Of Operation

System States

An internal state machine provides system control of the proximity detection and power management features of the device. At power up, an internal power-ON-reset initializes the device and puts it in a low-power Sleep state.

When a start condition is detected on the I²C bus, the device transitions to the Idle state where it checks the Enable register (0x00) PON bit. If PON is disabled, the device will return to the Sleep state to save power. Otherwise, the device will remain in the Idle state until the proximity function is enabled. Once enabled, the device will execute the Prox and Wait states in sequence as indicated in Figure 19. Upon completion and return to Idle, the device will automatically begin a new prox-wait cycle as long as PON and PEN remain enabled.

If the Prox function generates an interrupt and the Sleep-After-Interrupt (SAI) feature is enabled, the device will transition to the Sleep state and remain in a low-power mode until an I²C command is received. See the [Interrupts](#) section for additional information.

Figure 19:
Simplified State Diagram

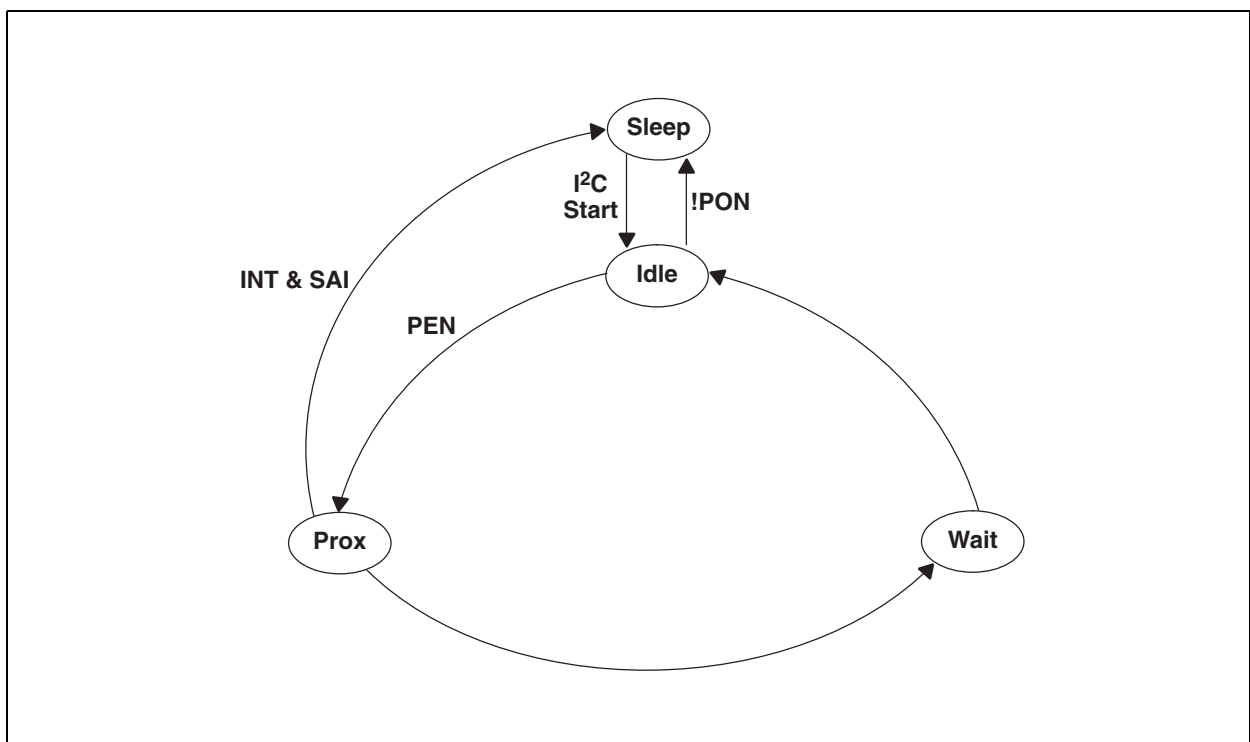

Proximity Detection

Proximity detection is accomplished by measuring the amount of light energy, generally from an IR LED, reflected off an object to determine its distance. The proximity light source, which is external to the TSL2672 device, is driven by the integrated proximity LED current driver as shown in Figure 20.

Figure 20: Proximity Detection

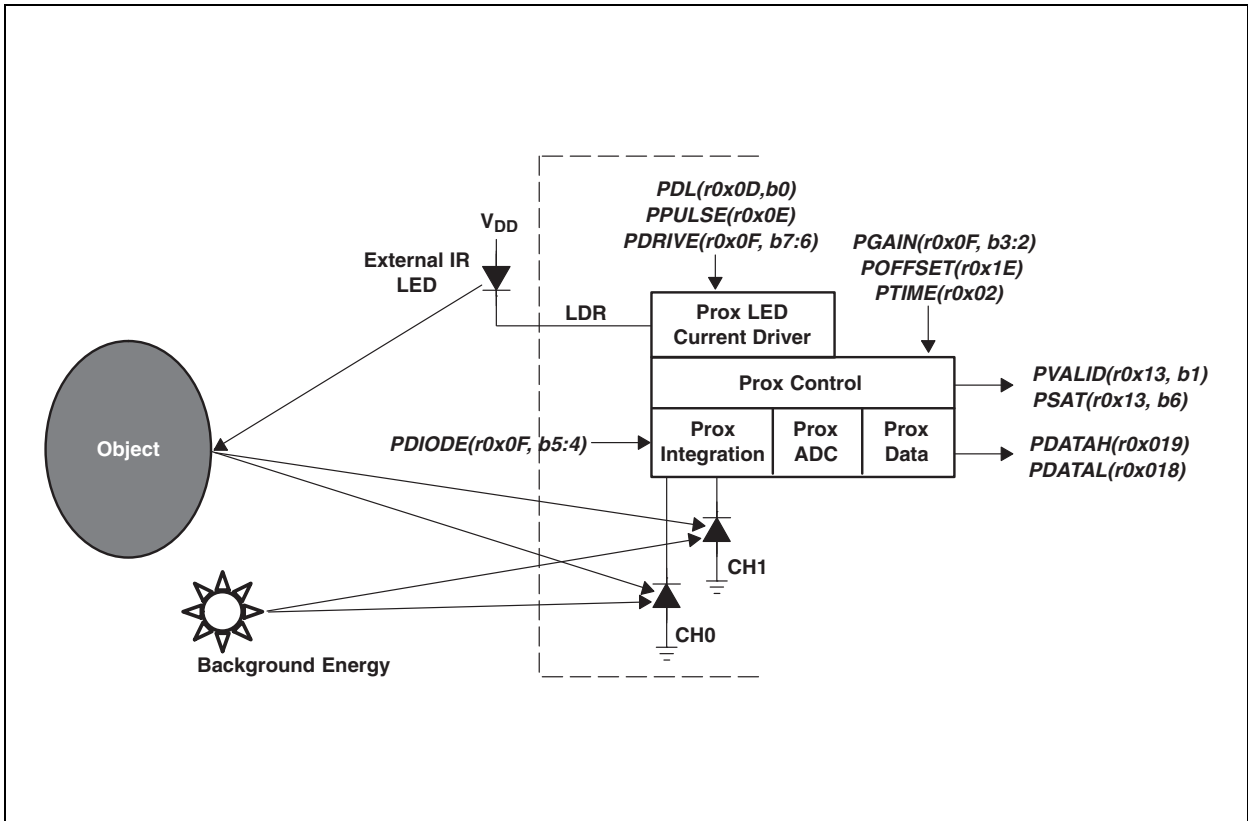

The LED current driver, output on the LDR terminal, provides a regulated current sink that eliminates the need for an external current limiting resistor. The combination of proximity LED drive strength (PDRIVE) and proximity drive level (PDL) determine the drive current. PDRIVE sets the drive current to 120 mA, 60 mA, 30 mA, or 15 mA when PDL is not asserted. However, when PDL is asserted, the drive current is reduced by a factor of about 8 at $V_{LDR} = 1.6\text{ V}$. To drive an external light source with more than 120 mA or to minimize ON-chip ground bounce, LDR can be used to drive an external p-type transistor, which in turn drives the light source.

Referring to the Detailed State Machine figure, the LED current driver pulses the external IR LED as shown in Figure 21 during the Prox Accum state. Figure 21 also illustrates that the LED ON pulse has a fixed width of 7.3 μs and period of 16.0 μs . So, in addition to setting the proximity drive current, 1 to 255 proximity pulses (PPULSE) can be programmed. When deciding

on the number of proximity pulses, keep in mind that the signal increases proportionally to PPULSE, while noise increases by the square root of PPULSE.

Figure 21:
Proximity LED Current Driver Waveform

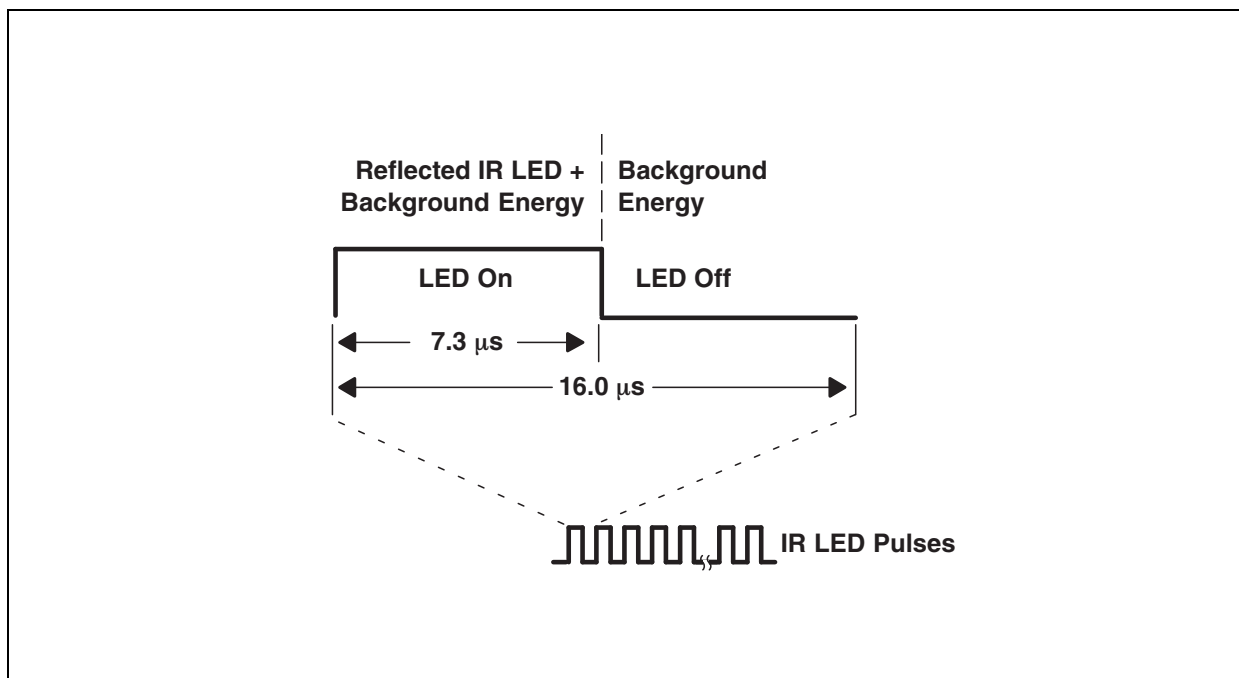

Figure 20 illustrates light rays emitting from an external IR LED, reflecting off an object, and being absorbed by the CH0 and CH1 photodiodes. The proximity diode selector (PDIODE) determines which of the two photodiodes is used for a given proximity measurement. Note that neither photodiode is selected when the device first powers up, so PDIODE must be set for proximity detection to work.

Referring again to Figure 21, the reflected IR LED and the background energy is integrated during the LED ON time, then during the LED OFF time, the integrated background energy is subtracted from the LED ON time energy, leaving the external IR LED energy to accumulate from pulse to pulse. The proximity gain (PGAIN) determines the integration rate, which can be programmed to 1×, 2×, 4×, or 8× gain. At power up, PGAIN defaults to 1× gain, which is recommended for most applications. For reference, PGAIN equal to 8× is comparable to the TSL2771 1× gain setting. During LED On time integration, the proximity saturation bit in the Status register (0x13) will be set if the integrator saturates. This condition can occur if the proximity gain is set too high for the lighting conditions, such as in the presence of bright sunlight. Once asserted, PSAT will remain set until a special function proximity interrupt clear command is received from the host (see [Command Register](#)).

After the programmed number of proximity pulses have been generated, the proximity ADC converts and scales the proximity measurement to a 16-bit value, then stores the result in two

8-bit proximity data (PDATAx) registers. ADC scaling is controlled by the proximity ADC conversion time (PTIME) which is programmable from 1 to 256 2.73-ms time units. However, depending on the application, scaling the proximity data will equally scale any accumulated noise. Therefore, in general, it is recommended to leave PTIME at the default value of one 2.73-ms ADC conversion time (0xFF).

In many practical proximity applications, a number of optical system and environmental conditions can produce an offset in the proximity measurement result. To counter these effects, a proximity offset (POFFSET) is provided which allows the proximity data to be shifted positive or negative. Additional information on the use of the proximity offset feature is provided in available **ams** application notes.

Once the first proximity cycle has completed, the proximity valid (PVALID) bit in the Status register will be set and remain set until the proximity detection function is disabled (PEN).

For additional information on using the proximity detection function behind glass and for optical system design guidance, please see available **ams** application notes.

Interrupts

The interrupt feature simplifies and improves system efficiency by eliminating the need to poll the sensor for proximity values outside a user-defined range. While the interrupt function is always enabled and its status is available in the Status register (0x13), the output of the interrupt state can be enabled using the proximity interrupt enable (PIEN) field in the Enable register (0x00).

Two 16-bit interrupt threshold registers allow the user to set limits below and above a desired proximity range. An interrupt can be generated when the proximity data (PDATA) is less than the proximity interrupt low threshold (PILTx) or is greater than the proximity interrupt high threshold (PIHTx).

It is important to note that the thresholds are evaluated in sequence, first the low threshold, then the high threshold. As a result, if the low threshold is set above the high threshold, the high threshold is ignored and only the low threshold is evaluated.

To further control when an interrupt occurs, the device provides an interrupt persistence feature. The persistence filter allows the user to specify the number of consecutive out-of-range proximity occurrences before an interrupt is generated. The persistence filter register (0x0C) allows the user to set the proximity persistence filter (PPERS) values. See the persistence filter register for details on the persistence filter values. Once the persistence filter generates an interrupt, it will continue until a special function interrupt clear command is received (see [Command Register](#)).

Figure 22:
Programmable Interrupt

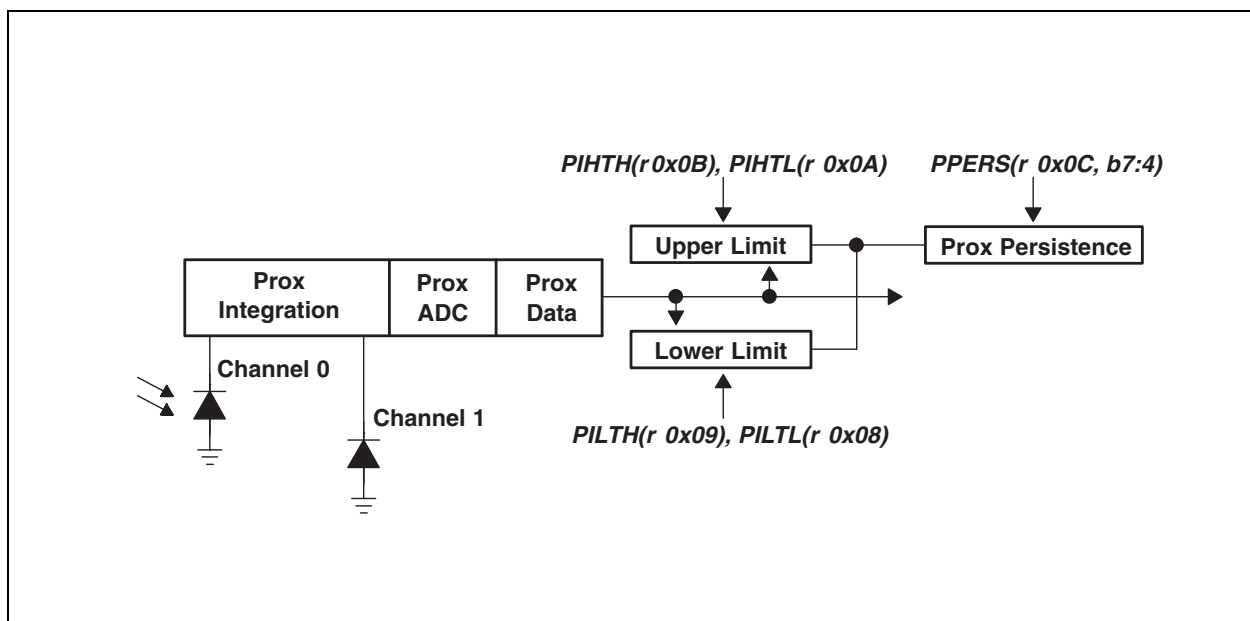

System Timing

The system state machine shown in Figure 19 provides an overview of the states and state transitions that provide system control of the device. This section highlights the programmable features, which affect the state machine cycle time, and provides details to determine system level timing.

When the proximity detection feature is enabled (PEN), the state machine transitions through the Prox Init, Prox Accum, Prox Wait, and Prox ADC states. The Prox Init and Prox Wait times are a fixed 2.73 ms, whereas the Prox Accum time is determined by the number of proximity LED pulses (PPULSE) and the Prox ADC time is determined by the integration time (PTIME). The formulas to determine the Prox Accum and Prox ADC times are given in the associated boxes in Figure 22. If an interrupt is generated as a result of the proximity cycle, it will be asserted at the end of the Prox ADC state and transition to the Sleep state if SAI is enabled.

When the power management feature is enabled (WEN), the state machine will transition in turn to the Wait state. The wait time is determined by WLONG, which extends normal operation by 12x when asserted, and WTIME. The formula to determine the wait time is given in the box associated with the Wait state in Figure 23.

Figure 23:
Detailed State Diagram

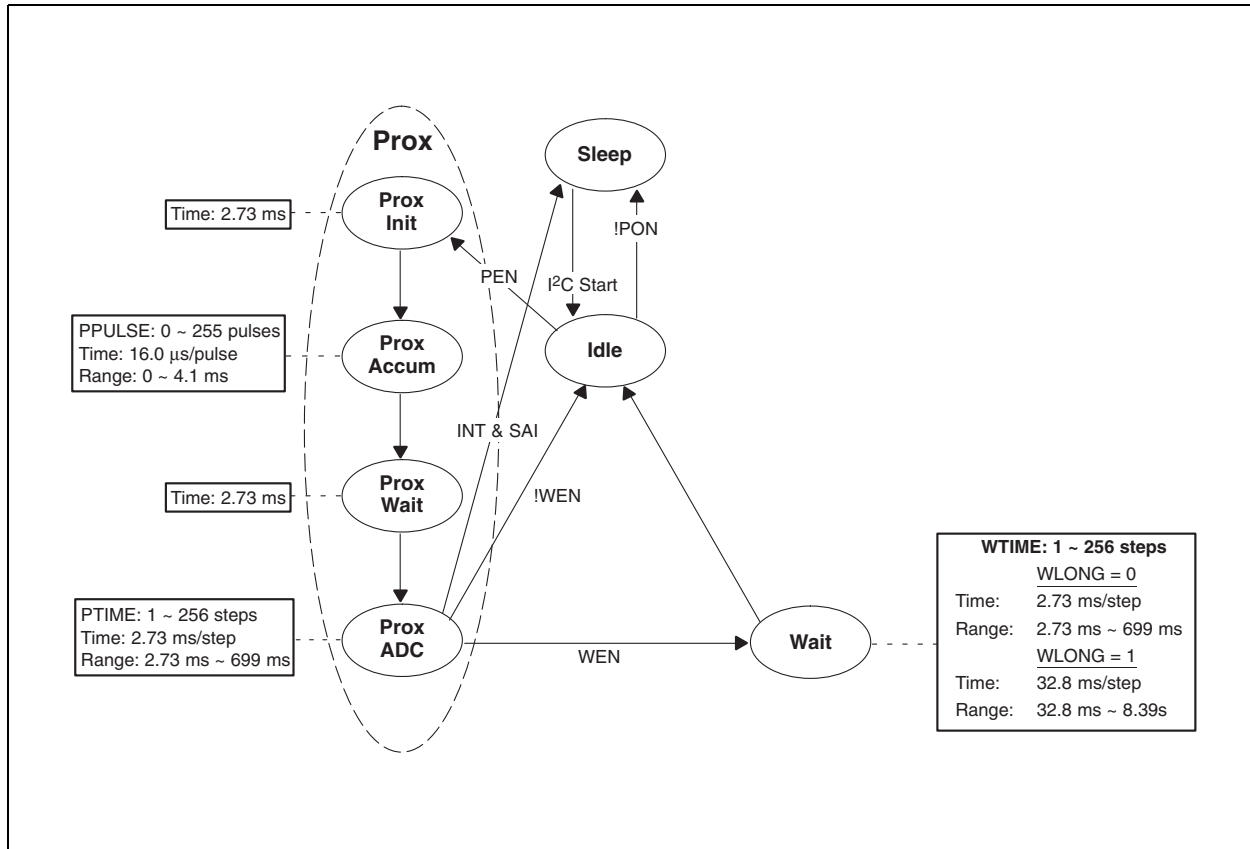

Note(s):

1. PON, WEN, AEN, and SAI are fields in the Enable register (0x00).

Power Management

Power consumption can be managed with the Wait state, because the Wait state typically consumes only 90µA of I_{DD} current. An example of the power management feature is given below. With the assumptions provided in the example, average I_{DD} is estimated to be 167 µA.

Figure 24:
Power Management

System State Machine State	Programmable Parameter	Programmed Value	Duration	Typical Current
Prox Init			2.73 ms	0.200 mA
Prox Accum	PPULSE	0x04	0.064 ms	
Prox Accum – LED ON			0.029 ms ⁽¹⁾	119 mA
Prox Accum – LED OFF			0.035 ms ⁽²⁾	0.200 mA
Prox Wait			2.73 ms	0.200 mA
Prox ADC	PTIME	0xFF	2.73 ms	0.200 mA
Wait	WTIME	0xEE	49.2 ms	0.090 mA
	WLONG	0		

Note(s):

1. Prox Accum - LED ON time = 7.3µs per pulse × 4 pulses = 29.3µs = 0.029 ms
2. Prox Accum - LED OFF time = 8.7 µs per pulse × 4 pulses = 34.7µs = 0.035 ms

$$\text{Average } I_{DD} \text{ Current} = ((0.029 \times 119) + (0.035 \times 0.200) + (2.73 \times 0.200) + (49.2 \times 0.090) + (2.73 \times 0.200 \times 2)) / 57 \approx 167 \mu\text{A}$$

Keeping with the same programmed values as the example, [Figure 25](#) shows how the average I_{DD} current is affected by the Wait state time, which is determined by WEN, WTIME, and WLONG. Note that the worst-case current occurs when the Wait state is not enabled.

Figure 25:
Average I_{DD} Current

WEN	WTIME	WLONG	WAIT State	Average I _{DD} Current
0	n/a	n/a	0 ms	622 μ A
1	0xFF	0	2.73 ms	490 μ A
1	0xEE	0	49.2 ms	167 μ A
1	0x00	0	699 ms	97 μ A
1	0x00	1	8389 ms	91 μ A

I²C Protocol

Interface and control are accomplished through an I²C serial compatible interface (standard or fast mode) to a set of registers that provide access to device control functions and output data. The devices support the 7-bit I²C addressing protocol.

The I²C standard provides for three types of bus transaction: read, write, and a combined protocol (Figure 26). During a write operation, the first byte written is a command byte followed by data. In a combined protocol, the first byte written is the command byte followed by reading a series of bytes. If a read command is issued, the register address from the previous command will be used for data access. Likewise, if the MSB of the command is not set, the device will write a series of bytes at the address stored in the last valid command with a register address. The command byte contains either control information or a 5-bit register address. The control commands can also be used to clear interrupts.

The I²C bus protocol was developed by Philips (now NXP). For a complete description of the I²C protocol, please review the NXP I²C design specification at <http://www.i2c-bus.org/references/>.

Figure 26:
I²C Protocols

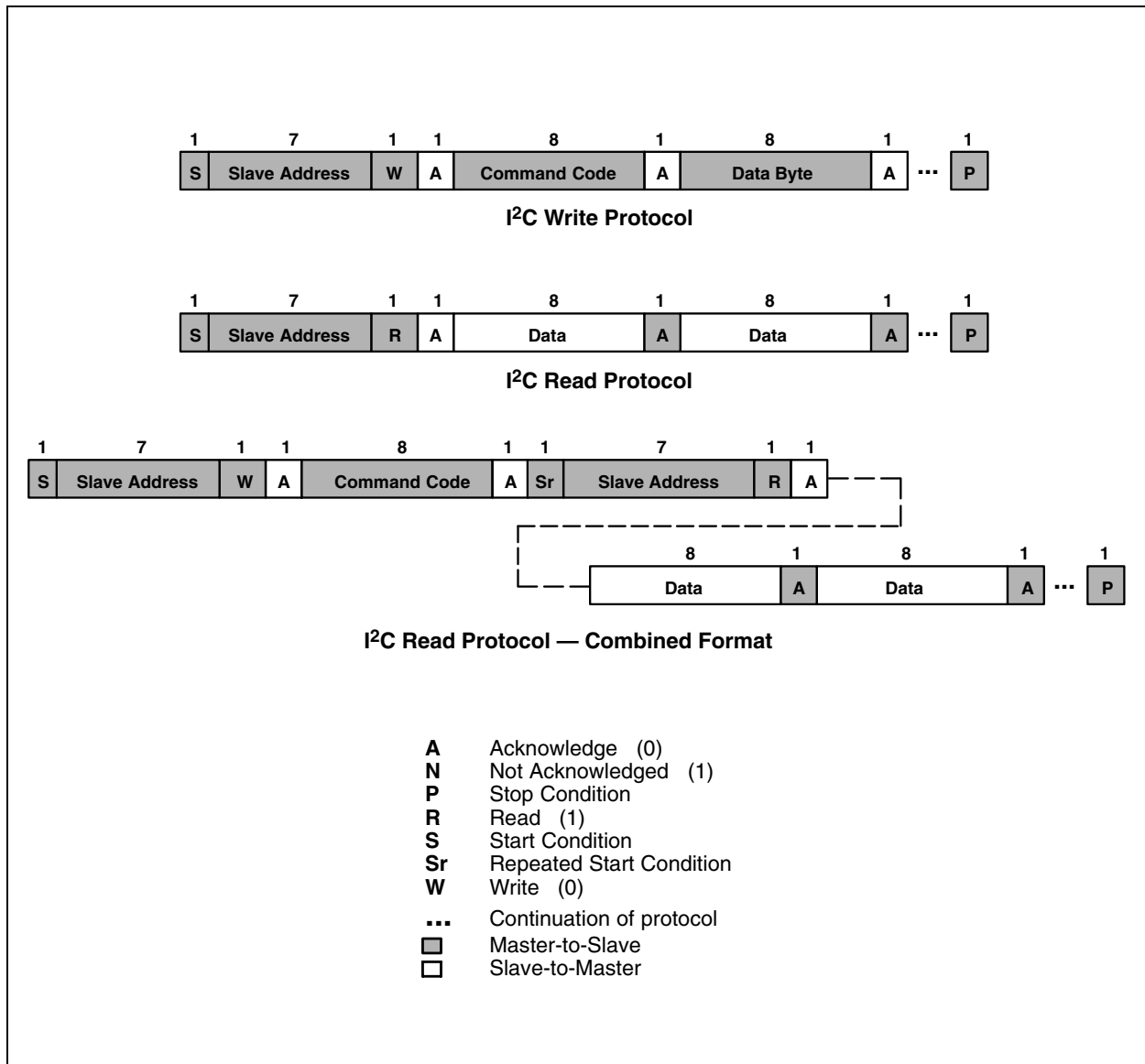

Register Set

The device is controlled and monitored by data registers and a command register accessed through the serial interface. These registers provide for a variety of control functions and can be read to determine results of the ADC conversions. The register set is summarized in [Figure 27](#).

Figure 27:
Register Address

Address	Register Name	R/W	Register Function	Reset Value
--	COMMAND	W	Specifies register address	0x00
0x00	ENABLE	R/W	Enables states and interrupts	0x00
0x02	PTIME	R/W	Proximity ADC time	0xFF
0x03	WTIME	R/W	Wait time	0xFF
0x08	PILTL	R/W	Proximity interrupt low threshold low byte	0x00
0x09	PILTH	R/W	Proximity interrupt low threshold high byte	0x00
0x0A	PIHTL	R/W	Proximity interrupt high threshold low byte	0x00
0x0B	PIHTH	R/W	Proximity interrupt high threshold high byte	0x00
0x0C	PERS	R/W	Interrupt persistence filters	0x00
0x0D	CONFIG	R/W	Configuration	0x00
0x0E	PPULSE	R/W	Proximity pulse count	0x00
0x0F	CONTROL	R/W	Control register	0x00
0x12	ID	R	Device ID	ID
0x13	STATUS	R	Device status	0x00
0x18	PDATA L	R	Proximity data low byte	0x00
0x19	PDATA H	R	Proximity data high byte	0x00
0x1E	POFFSET	R/W	Proximity Offset register	0x00

The mechanics of accessing a specific register depends on the specific protocol used. See the section on [I²C Protocol](#) on the previous pages. In general, the COMMAND register is written first to specify the specific control-status-data register for subsequent read/write operations.

Command Register

The command register specifies the address of the target register for future read and write operations, as well as issues special function commands.

Figure 28:
Command Register

	7	6	5	4	3	2	1	0
	CMD	TYPE	ADDR/SF					

Field	Bits	Description	
CMD	7	Select Command Register. Must write as 1 when addressing COMMAND register.	
TYPE	6:5	Selects type of transaction to follow in subsequent data transfers:	
		FIELD VALUE	DESCRIPTION
		00	Repeated byte protocol transaction
		01	Auto-increment protocol transaction
		10	Reserved — Do not use
		11	Special function — See description below
		Transaction type 00 will repeatedly read the same register with each data access. Transaction type 01 will provide an auto-increment function to read successive register bytes.	
ADDR/SF	4:0	Address field/special function field. Depending on the transaction type, see above, this field either specifies a special function command or selects the specific control-status-data register for subsequent read and write transactions. The field values listed below apply only to special function commands:	
		FIELD VALUE	DESCRIPTION
		00100	Interrupt set — forces an interrupt
		00101	Proximity interrupt clear
		other	Reserved — Do not write
		The interrupt set special function command sets the interrupt bits in the status register (0x13). For the interrupt to be visible on the INT pin, the proximity interrupt enable bit (PIEN) in the enable register (0x00) must be asserted. The interrupt set special function must be cleared with an interrupt clear special function. The proximity interrupt clear special function clears any pending interrupt and is self clearing.	

Enable Register (0x00)

The ENABLE register is used to power the device ON/OFF, enable functions, and interrupts.

Figure 29:
Enable Register

7	6	5	4	3	2	1	0
Reserved	SAI	PIEN	Reserved	WEN	PEN	Reserved	PON

Field	Bits	Description
Reserved	7	Reserved. Write as 0.
SAI	6	Sleep after interrupt. When asserted, the device will power down at the end of a proximity cycle if an interrupt has been generated
PIEN	5	Proximity interrupt enable. When enabled, the proximity interrupt drives the INT pin. When disabled, the interrupt is masked from the INT pin, but remains visible in the Status register (0x13).
Reserved	4	Reserved. Write as 0.
WEN	3	Wait enable. This bit activates the wait feature. Writing a 1 activates the wait timer. Writing a 0 disables the wait timer.
PEN	2	Proximity enable. This bit activates the proximity function. Writing a 1 enables proximity. Writing a 0 disables proximity.
Reserved	1	Reserved. Write as 0.
PON	0	Power ON. This bit activates the internal oscillator to permit the timers and ADC channel to operate. Writing a 1 activates the oscillator. Writing a 0 disables the oscillator.

Proximity Time Register (0x02)

The proximity timing register controls the integration time of the proximity ADC in 2.73 ms increments. Upon power up, the proximity time register is set to 0xFF. It is recommended that this register be programmed to a value of 0xFF (1 integration cycle).

Figure 30:
Proximity Integration Time Control Register

Field	Bits	Description			
PTIME	7:0	VALUE	INTEG_CYCLES	TIME	MAX COUNT
		0xFF	1	2.73 ms	1023

Wait Time Register (0x03)

Wait time is set 2.73 ms increments unless the WLONG bit is asserted in which case the wait times are 12x longer. WTIME is programmed as a 2's complement number. Upon power up, the wait time register is set to 0xFF.

Figure 31:
Wait Time Register

Field	Bits	Description			
		REGISTER VALUE	WAIT TIME	TIME (WLONG = 0)	TIME (WLONG = 1)
WTIME	7:0	0xFF	1	2.73 ms	0.033 s
		0xB6	74	202 ms	2.4 s
		0x00	256	699 ms	8.4 s

Note(s):

1. The Proximity Wait Time Register should be configured before PEN is asserted.

Proximity Interrupt Threshold Registers (0x08 - 0x0B)

The proximity interrupt threshold registers provide the upper and lower threshold values to the proximity interrupt comparators. See Interrupts in the [Principles Of Operation](#) section for detailed information. Upon power up, the interrupt threshold registers reset to 0x00.

Figure 32:
Proximity Interrupt Threshold Registers

Register	Address	Bits	Description
PILTL	0x08	7:0	Proximity low threshold low byte
PILTH	0x09	7:0	Proximity low threshold high byte
PIHTL	0x0A	7:0	Proximity high threshold low byte
PIHTH	0x0B	7:0	Proximity high threshold high byte

Interrupt Persistence Filter Register (0x0C)

The interrupt persistence filter sets the number of consecutive proximity cycles that are out-of-range before an interrupt is generated. Out-of-range is determined by the proximity interrupt threshold registers (0x08 through 0x0B). See Interrupts in the [Principles Of Operation](#) section for further information. Upon power up, the interrupt persistence filter register resets to 0x00, which will generate an interrupt at the end of each proximity cycle.

Figure 33:
Interrupt Persistence Filter Register

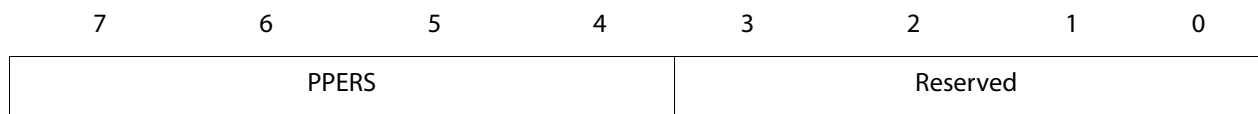

Field	Bits	Description	
PPERS	7:4	Proximity persistence. Controls rate of proximity interrupt to the host processor	
		FIELD VALUE	INTERRUPT PERSISTENCE FUNCTION
		0000	Every proximity cycle generates an interrupt
		0001	1 proximity value out of range
		0010	2 consecutive proximity values out of range
	
		1111	15 consecutive proximity values out of range
Reserved	3:0	Reserved. Write as 0.	

Configuration Register (0x0D)

The configuration register sets the proximity LED drive level and wait long time.

Figure 34:
Configuration Register

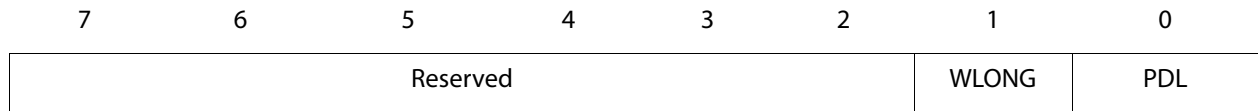

Field	Bits	Description
Reserved	7:2	Reserved. Write as 0.
WLONG	1	Wait Long. When asserted, the wait cycles are increased by a factor 12x from that programmed in the WTIME register.
PDL	0	Proximity drive level. When asserted, the proximity LDR drive current is reduced by 9.

Proximity Pulse Count Register (0x0E)

The proximity pulse count register sets the number of proximity pulses that the LDR pin will generate during the Prox Accum state.

Figure 35:
Proximity Pulse Count Register

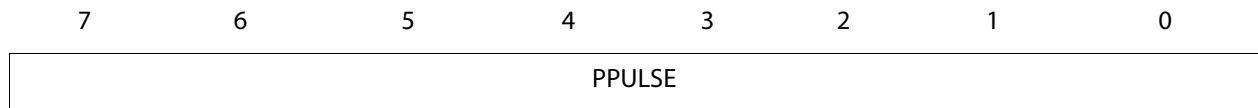

Field	Bits	Description
PPULSE	7:0	Proximity Pulse Count. Specifies the number of proximity pulses to be generated.

Control Register (0x0F)

The Control register provides eight bits of miscellaneous control to the analog block. These bits typically control functions such as gain settings and/or diode selection.

Figure 36:
Control Register

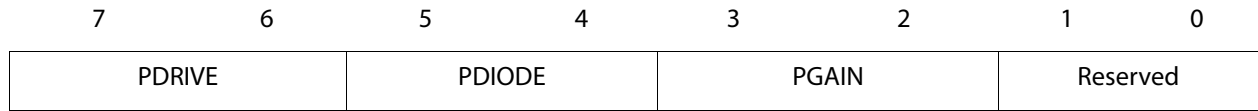

Field	Bits	Description		
PDRIVE ⁽¹⁾	7:6	Proximity LED Drive Strength.		
		FIELD VALUE	LED STRENGTH — PDL = 0	LED STRENGTH — PDL = 1
		00	120 mA	15 mA
		01	60 mA	7.5 mA
		10	30 mA	3.8 mA
		11	15 mA	1.9 mA
PDIODE	5:4	Proximity Diode Selector.		
		FIELD VALUE	DIODE SELECTION	
		00	Proximity uses neither diode	
		01	Proximity uses the CH0 diode	
		10	Proximity uses the CH1 diode	
		11	Reserved — Do not write	
PGAIN	3:2	Proximity Gain.		
		FIELD VALUE	PROXIMITY GAIN VALUE	
		00	1× gain	
		01	2× gain	
		10	4× gain	
		11	8× gain	
Reserved	1:0	Reserved. Write as 0.		

Note(s):

1. LED STRENGTH currents are nominal values. Specifications can be found in the Proximity Characteristics table.

ID Register (0x12)

The ID Register provides the value for the part number. The ID register is a read-only register.

Figure 37:
ID Register

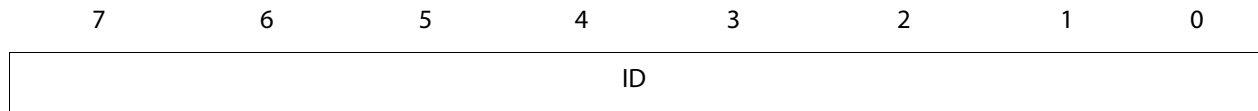

Field	Bits	Description	
ID	7:0	Part number identification	0x32 = TSL26721 & TSL26725
			0x3B = TSL26723 & TSL26727

Status Register (0x13)

The Status Register provides the internal status of the device. This register is read only.

Figure 38:
Status Register

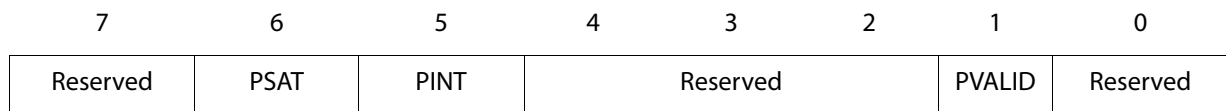

Field	Bit	Description
Reserved	7	Reserved. Read as 0.
PSAT	6	Proximity Saturation. Indicates that the proximity measurement saturated.
PINT	5	Proximity Interrupt. Indicates that the device is asserting a proximity interrupt.
Reserved	4:2	Reserved. Read as 0.
PVALID	1	Proximity Valid. Indicates that the proximity channel has completed an integration cycle after PEN has been asserted.
Reserved	0	Reserved. Read as 0.

Proximity Data Registers (0x18 - 0x19)

Proximity data is stored as a 16-bit value. When the lower byte is read, the upper byte is latched into a shadow register. The shadow register ensures that both bytes are the result of the same proximity cycle, even if additional proximity cycles occur between the lower byte and upper byte register readings. The simplest way to read both bytes is to perform a two-byte I²C read operation using the auto-increment protocol, which is set in the Command register TYPE field.

Figure 39:
Proximity Data Registers

Register	Address	Bits	Description
PDATA _L	0x18	7:0	Proximity data low byte
PDATA _H	0x19	7:0	Proximity data high byte

Proximity Offset Register (0x1E)

The 8-bit proximity offset register provides compensation for proximity offsets caused by device variations, optical crosstalk, and other environmental factors. Proximity offset is a sign-magnitude value where the sign bit, bit 7, determines if the offset is negative (bit 7 = 0) or positive (bit 7 = 1). At power up, the register is set to 0x00. The magnitude of the offset compensation depends on the proximity gain (PGAIN), proximity LED drive strength (PDRIVE), and the number of proximity pulses (PPULSE). Because a number of environmental factors contribute to proximity offset, this register is best suited for use in an adaptive closed-loop control system. See available **ams** application notes for proximity offset register application information.

Figure 40:
Proximity Offset Register

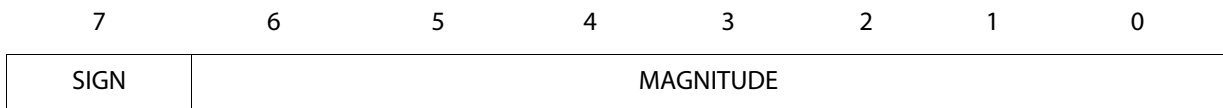

Field	Bit	Description
SIGN	7	Proximity Offset Sign. The offset sign shifts the proximity data negative when equal to 0 and positive when equal to 1.
MAGNITUDE	6:0	Proximity Offset Magnitude. The offset magnitude shifts the proximity data positive or negative, depending on the proximity offset sign. The actual amount of the shift depends on the proximity gain (PGAIN), proximity LED drive strength (PDRIVE), and the number of proximity pulses (PPULSE).

Application Information Hardware

LED Driver Pin with Proximity Detection

In a proximity sensing system, the IR LED can be pulsed by the TSL2672 with more than 100 mA of rapidly switching current, therefore, a few design considerations must be kept in mind to get the best performance. The key goal is to reduce the power supply noise coupled back into the device during the LED pulses.

The first recommendation is to use two power supplies; one for the device V_{DD} and the other for the IR LED. In many systems, there is a quiet analog supply and a noisy digital supply. By connecting the quiet supply to the V_{DD} pin and the noisy supply to the LED, the key goal can be met. Place a 1- μF low-ESR decoupling capacitor as close as possible to the V_{DD} pin and another at the LED anode, and a 22- μF capacitor at the output of the LED voltage regulator to supply the 100-mA current surge.

Figure 41:
Proximity Sensing Using Separate Power Supplies

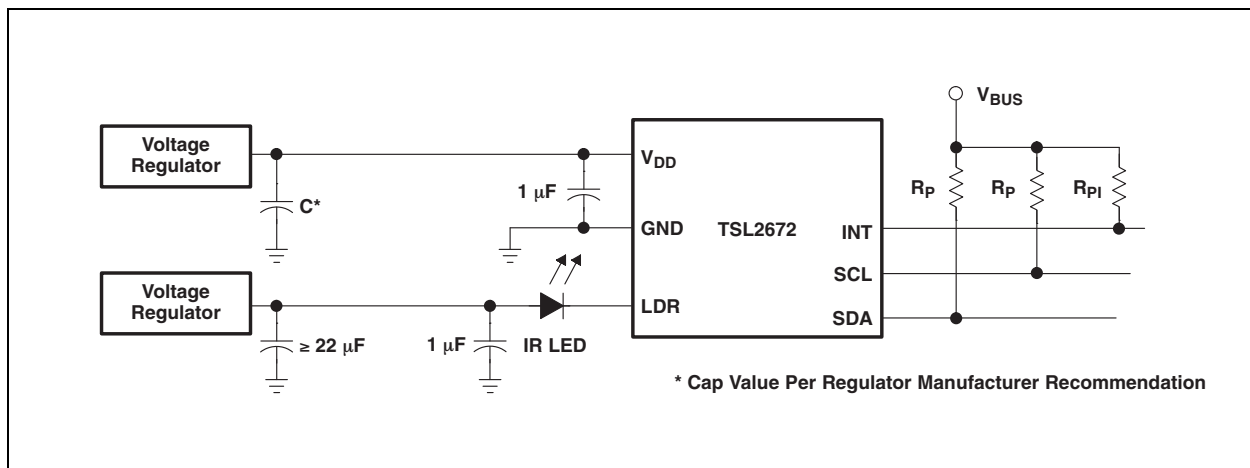

If it is not possible to provide two separate power supplies, the device can be operated from a single supply. A 22- Ω resistor in series with the V_{DD} supply line and a 1- μF low ESR capacitor effectively filter any power supply noise. The previous capacitor placement considerations apply.

Figure 42:
Proximity Sensing Using Single Power Supply

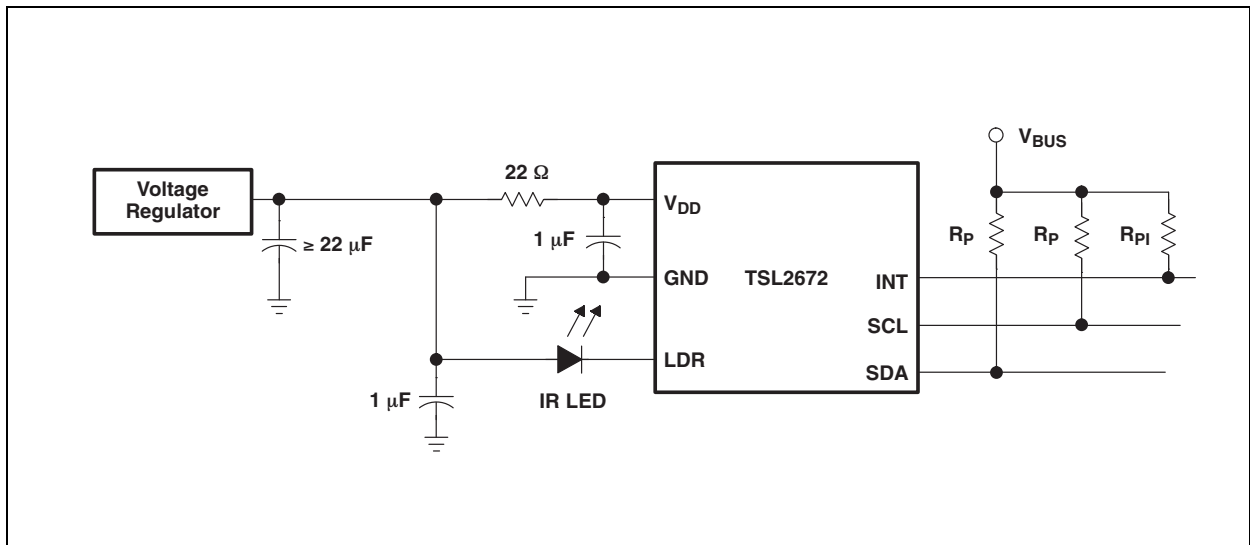

V_{BUS} in the above figures refers to the I²C bus voltage which is either V_{DD} or 1.8 V. Be sure to apply the specified I²C bus voltage shown in the [Ordering & Contact Information](#) for the specific device being used.

The I²C signals and the Interrupt are open-drain outputs and require pullup resistors. The pull-up resistor (R_p) value is a function of the I²C bus speed, the I²C bus voltage, and the capacitive load. The **ams** EVM running at 400 kbit/s, uses 1.5-kΩ resistors. A 10-kΩ pull-up resistor (R_{pi}) can be used for the interrupt line.

PCB Pad Layouts

Suggested land pattern based on the IPC-7351B Generic Requirements for Surface Mount Design and Land Pattern Standard (2010) for the small outline no-lead (SON) package is shown in [Figure 43](#).

Figure 43:
Suggested FN Package PCB Layout

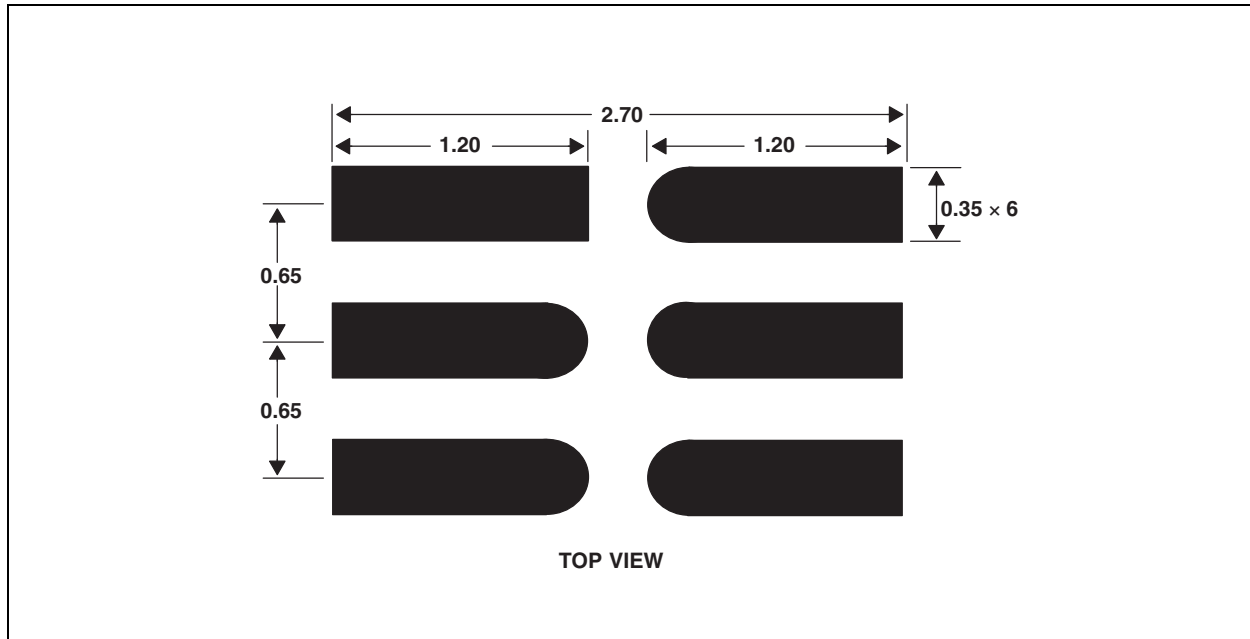

Note(s):

1. All linear dimensions are in millimeters.
2. This drawing is subject to change without notice.

Package Information

Figure 44:
Package FN — Dual Flat No-Lead Packaging Configuration

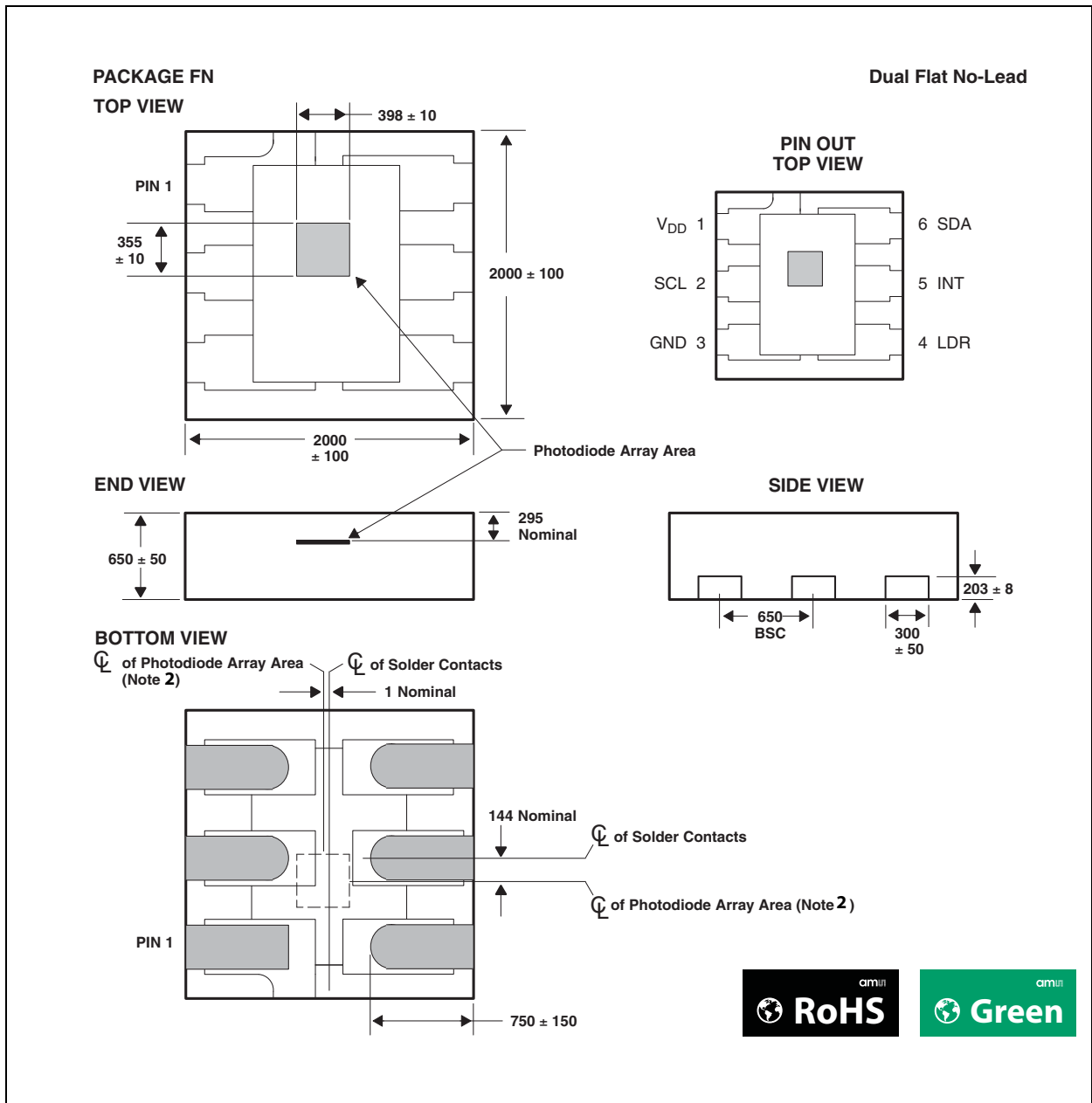

Note(s):

1. All linear dimensions are in micrometers.
2. The die is centered within the package within a tolerance of $\pm 75 \mu\text{m}$.
3. Package top surface is molded with an electrically nonconductive clear plastic compound having an index of refraction of 1.55.
4. Contact finish is copper alloy A194 with pre-plated NiPdAu lead finish.
5. This package contains no lead (Pb).
6. This drawing is subject to change without notice.



Carrier Tape & Reel Information

Figure 45:
Package FN Carrier Tape

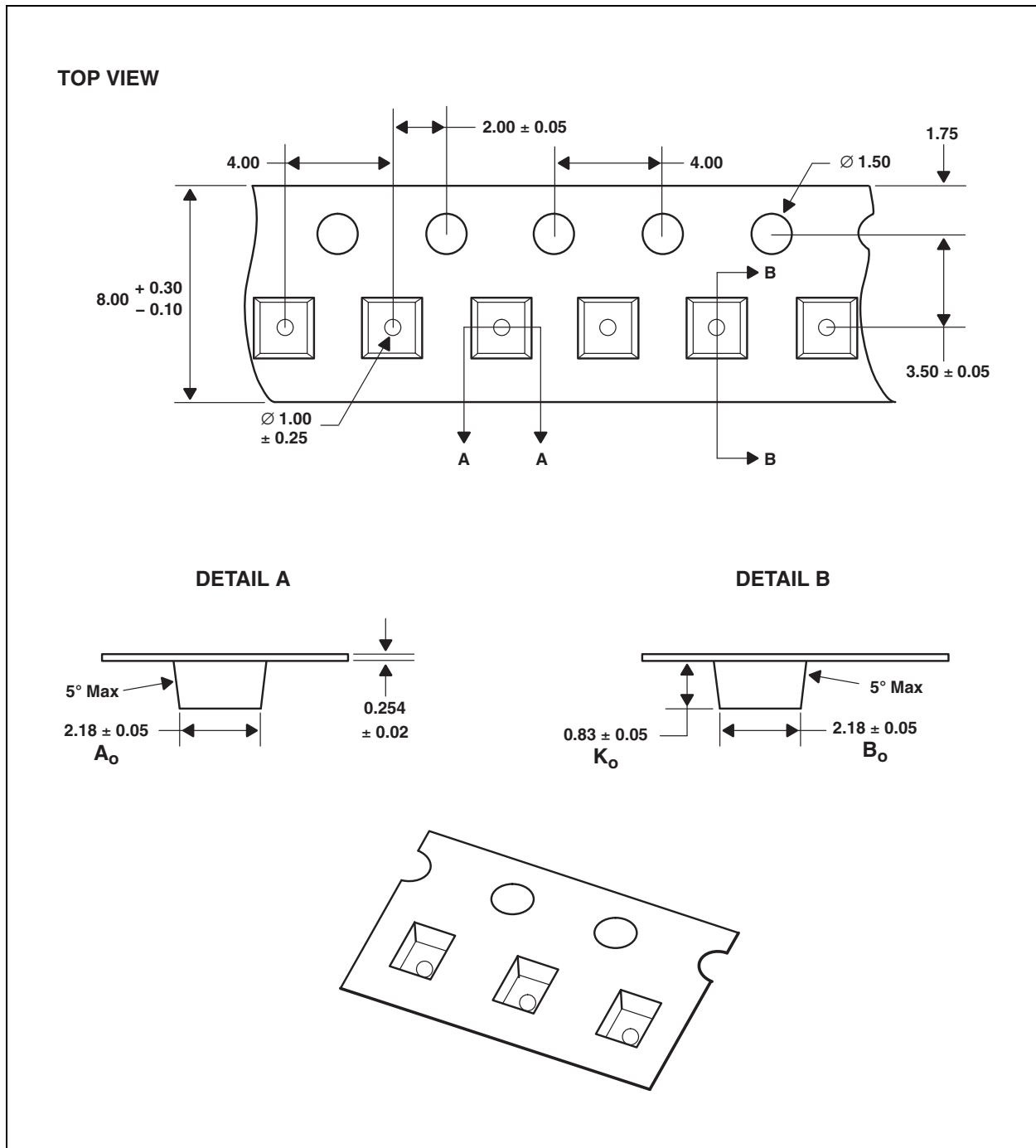

Note(s):

1. All linear dimensions are in millimeters. Dimension tolerance is ± 0.10 mm unless otherwise noted.
2. The dimensions on this drawing are for illustrative purposes only. Dimensions of an actual carrier may vary slightly.
3. Symbols on drawing A_o , B_o , and K_o are defined in ANSI EIA Standard 481-B 2001.
4. Each reel is 178 millimeters in diameter and contains 3500 parts.
5. **ams** packaging tape and reel conform to the requirements of EIA Standard 481-B.
6. In accordance with EIA standard, device pin 1 is located next to the sprocket holes in the tape.
7. This drawing is subject to change without notice.

Soldering Information

The FN package has been tested and has demonstrated an ability to be reflow soldered to a PCB substrate.

The solder reflow profile describes the expected maximum heat exposure of components during the solder reflow process of product on a PCB. Temperature is measured on top of component. The components should be limited to a maximum of three passes through this solder reflow profile.

Figure 46:
Solder Reflow Profile

Parameter	Reference	Device
Average temperature gradient in preheating		2.5°C/s
Soak time	t_{soak}	2 to 3 minutes
Time above 217°C (T1)	t_1	Max 60 s
Time above 230°C (T2)	t_2	Max 50 s
Time above $T_{peak} - 10^\circ\text{C}$ (T3)	t_3	Max 10 s
Peak temperature in reflow	T_{peak}	260°C
Temperature gradient in cooling		Max -5°C/s

Figure 47:
Solder Reflow Profile Graph

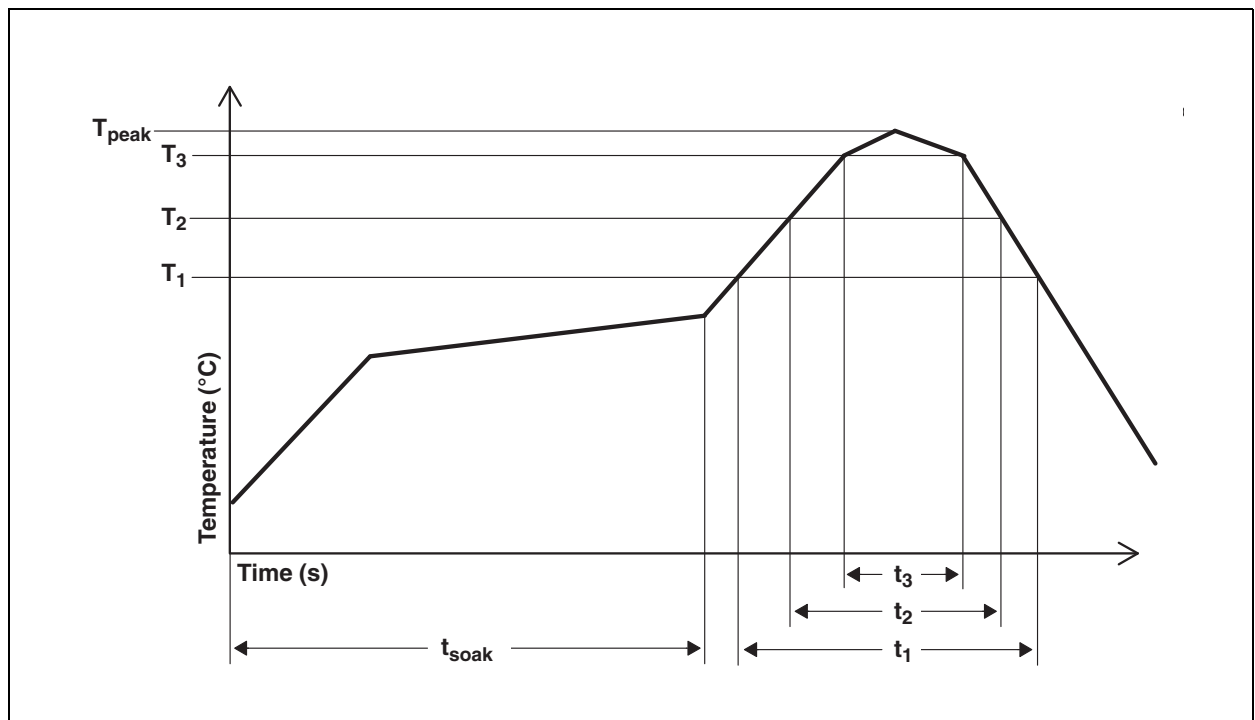

Note(s):

1. Not to scale - for reference only.

Storage Information

Moisture Sensitivity

Optical characteristics of the device can be adversely affected during the soldering process by the release and vaporization of moisture that has been previously absorbed into the package. To ensure the package contains the smallest amount of absorbed moisture possible, each device is dry-baked prior to being packed for shipping. Devices are packed in a sealed aluminized envelope called a moisture barrier bag with silica gel to protect them from ambient moisture during shipping, handling, and storage before use.

Shelf Life

The calculated shelf life of the device in an unopened moisture barrier bag is 12 months from the date code on the bag when stored under the following conditions:

- Shelf Life: 12 months
- Ambient Temperature: < 40°C
- Relative Humidity: < 90%

Rebaking of the devices will be required if the devices exceed the 12 month shelf life or the Humidity Indicator Card shows that the devices were exposed to conditions beyond the allowable moisture region.

Floor Life

The FN package has been assigned a moisture sensitivity level of MSL 3. As a result, the floor life of devices removed from the moisture barrier bag is 168 hours from the time the bag was opened, provided that the devices are stored under the following conditions:

- Floor Life: 168 hours
- Ambient Temperature: < 30°C
- Relative Humidity: < 60%

If the floor life or the temperature/humidity conditions have been exceeded, the devices must be rebaked prior to solder reflow or dry packing.

Rebaking Instructions

When the shelf life or floor life limits have been exceeded, rebake at 50°C for 12 hours.

Ordering & Contact Information

Figure 48:
Ordering Information

Ordering Code	Device	Address	Package - Leads	Interface Description
TSL26721FN	TSL26721	0x39	FN-6	I ² C Vbus = V _{DD} Interface
TSL26723FN	TSL26723	0x39	FN-6	I ² C Vbus = 1.8 V Interface
TSL26725FN	TSL26725 ⁽¹⁾	0x29	FN-6	I ² C Vbus = V _{DD} Interface
TSL26727FN	TSL26727 ⁽¹⁾	0x29	FN-6	I ² C Vbus = 1.8 V Interface

Note(s):

1. Contact **ams** for availability.

Buy our products or get free samples online at:

www.ams.com/Products

Technical Support is available at:

www.ams.com/Technical-Support

Provide feedback about this document at:

www.ams.com/Document-Feedback

For further information and requests, e-mail us at:

ams_sales@ams.com

For sales offices, distributors and representatives, please visit:

www.ams.com/Contact

Headquarters

ams AG
Tobelbaderstrasse 30
8141 Premstaetten
Austria, Europe

Tel: +43 (0) 3136 500 0

Website: www.ams.com

RoHS Compliant & ams Green Statement

RoHS: The term RoHS compliant means that ams AG products fully comply with current RoHS directives. Our semiconductor products do not contain any chemicals for all 6 substance categories, including the requirement that lead not exceed 0.1% by weight in homogeneous materials. Where designed to be soldered at high temperatures, RoHS compliant products are suitable for use in specified lead-free processes.

ams Green (RoHS compliant and no Sb/Br): ams Green defines that in addition to RoHS compliance, our products are free of Bromine (Br) and Antimony (Sb) based flame retardants (Br or Sb do not exceed 0.1% by weight in homogeneous material).

Important Information: The information provided in this statement represents ams AG knowledge and belief as of the date that it is provided. ams AG bases its knowledge and belief on information provided by third parties, and makes no representation or warranty as to the accuracy of such information. Efforts are underway to better integrate information from third parties. ams AG has taken and continues to take reasonable steps to provide representative and accurate information but may not have conducted destructive testing or chemical analysis on incoming materials and chemicals. ams AG and ams AG suppliers consider certain information to be proprietary, and thus CAS numbers and other limited information may not be available for release.

Copyrights & Disclaimer

Copyright ams AG, Tobelbader Strasse 30, 8141 Premstaetten, Austria-Europe. Trademarks Registered. All rights reserved. The material herein may not be reproduced, adapted, merged, translated, stored, or used without the prior written consent of the copyright owner.

Devices sold by ams AG are covered by the warranty and patent indemnification provisions appearing in its General Terms of Trade. ams AG makes no warranty, express, statutory, implied, or by description regarding the information set forth herein. ams AG reserves the right to change specifications and prices at any time and without notice. Therefore, prior to designing this product into a system, it is necessary to check with ams AG for current information. This product is intended for use in commercial applications. Applications requiring extended temperature range, unusual environmental requirements, or high reliability applications, such as military, medical life-support or life-sustaining equipment are specifically not recommended without additional processing by ams AG for each application. This product is provided by ams AG "AS IS" and any express or implied warranties, including, but not limited to the implied warranties of merchantability and fitness for a particular purpose are disclaimed.

ams AG shall not be liable to recipient or any third party for any damages, including but not limited to personal injury, property damage, loss of profits, loss of use, interruption of business or indirect, special, incidental or consequential damages, of any kind, in connection with or arising out of the furnishing, performance or use of the technical data herein. No obligation or liability to recipient or any third party shall arise or flow out of ams AG rendering of technical or other services.

Document Status

Document Status	Product Status	Definition
Product Preview	Pre-Development	Information in this datasheet is based on product ideas in the planning phase of development. All specifications are design goals without any warranty and are subject to change without notice
Preliminary Datasheet	Pre-Production	Information in this datasheet is based on products in the design, validation or qualification phase of development. The performance and parameters shown in this document are preliminary without any warranty and are subject to change without notice
Datasheet	Production	Information in this datasheet is based on products in ramp-up to full production or full production which conform to specifications in accordance with the terms of ams AG standard warranty as given in the General Terms of Trade
Datasheet (discontinued)	Discontinued	Information in this datasheet is based on products which conform to specifications in accordance with the terms of ams AG standard warranty as given in the General Terms of Trade, but these products have been superseded and should not be used for new designs

Revision Information

Changes from 1-00 (2016-Mar-23) to current revision 1-01 (2019-Nov-20)	Page
Updated “Key Benefits & Features” (unit mA was replaced with μ A)	2

Note(s):

1. Page and figure numbers for the previous version may differ from page and figure numbers in the current revision
2. Correction of typographical errors is not explicitly mentioned.

Content Guide

1	General Description
1	Key Benefits & Features
2	Applications
2	End Products and Market Segments
3	Functional Block Diagram
4	Pin Assignments
5	Detailed Description
6	Absolute Maximum Ratings
10	Parameter Measurement Information
11	Typical Characteristics
15	Principles Of Operation
15	System States
16	Proximity Detection
19	Interrupts
20	System Timing
21	Power Management
22	I ² C Protocol
24	Register Set
25	Command Register
26	Enable Register (0x00)
26	Proximity Time Register (0x02)
27	Wait Time Register (0x03)
27	Proximity Interrupt Threshold Registers (0x08 - 0x0B)
28	Interrupt Persistence Filter Register (0x0C)
29	Configuration Register (0x0D)
29	Proximity Pulse Count Register (0x0E)
30	Control Register (0x0F)
31	ID Register (0x12)
31	Status Register (0x13)
32	Proximity Data Registers (0x18 - 0x19)
32	Proximity Offset Register (0x1E)
33	Application Information Hardware
33	LED Driver Pin with Proximity Detection
35	PCB Pad Layouts
36	Package Information
37	Carrier Tape & Reel Information
38	Soldering Information
39	Storage Information
39	Moisture Sensitivity
39	Shelf Life
39	Floor Life
39	Rebaking Instructions
40	Ordering & Contact Information

- 41 RoHS Compliant & ams Green Statement**
- 42 Copyrights & Disclaimer**
- 43 Document Status**
- 44 Revision Information**

X-ON Electronics

Largest Supplier of Electrical and Electronic Components

Click to view similar products for [Optical Sensor Development Tools](#) category:

Click to view products by [ams](#) manufacturer:

Other Similar products are found below :

[MT9V034C12STCH-GEVB](#) [MT9V115EBKSTCH-GEVB](#) [416015300-3](#) [ISL29102IROZ-EVALZ](#) [MT9M021IA3XTMH-GEVB](#)
[AR1335CSSC11SMKAH3-GEVB](#) [MAXCAMOV10640#](#) [MT9M031I12STMH-GEVB](#) [TSL2581CS-DB](#) [TMD3700-DB](#) [NANOUSB2.2](#)
[ASX340AT3C00XPEDH3-GEVB](#) [AR0144ATSM20XUEAH3-GEVB](#) [AR0144CSSC00SUKAH3-GEVB](#) [AR0522SRSC09SURAH3-GEVB](#)
[AR0522SRSM09SURAH3-GEVB](#) [AR0521SR2C09SURAH3-GEVB](#) [MARS1-MAX9295A-GEVK](#) [MARS1-MAX9296B-GEVB](#)
[ISL29112IROZ-EVALZ](#) [AR0233AT2C17XUEAH3-GEVB](#) [AR0431CSSC14SMRAH3-GEVB](#) [MARS-DEMO3-MIPI-GEVB](#) [TCS3430-DB](#)
[AR0234CSSC00SUKAH3-GEVB](#) [AR0130CSSM00SPCAH-GEVB](#) [TSL2521-DB](#) [TSL2520-DB](#) [EVALZ-ADPD2212](#) [TMD2772EVM](#)
[TMG3993EVM](#) [MIKROE-2103](#) [TSL2672EVM](#) [1384](#) [MT9M114EBLSTCZDH-GEVB](#) [SEN0043](#) [SEN0162](#) [TMD2771EVM](#) [TMD3782EVM](#)
[TSL4531EVM](#) [1918](#) [AS7225 DEMO KIT](#) [SEN0097](#) [SEN0212](#) [SEN0228](#) [AR0134CSSC00SUEAH3-GEVB](#) [AP0100AT2L00XUGAH3-GEVB](#) [AR0144CSSM20SUKAH3-GEVB](#) [725-28915](#) [EVAL-ADPD1081Z-PPG](#)