

## Small Signal Schottky DIODE / DATA SHEET

### BAT54M5

- ◇ Low Forward Voltage Drop
- ◇ **SOD523** Micro SMD package
- ◇ RoHS compliant / Green EMC
- ◇ Matte Tin (Sn) Lead finish
- ◇ Cathode Band / Device marking
- ◇ Surface Mount Package Ideally Suited for Automatic Insertion

Device Marking Code	
BAT54M5	JV

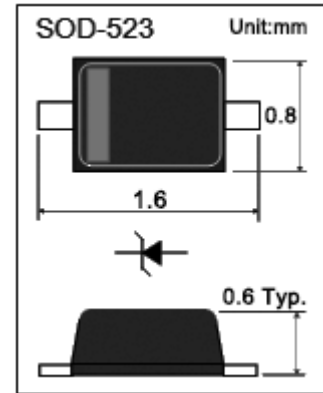

### Maximum Ratings (Ta = 25 °C)

Symbol	Parameter	Value	Units
$V_{RRM}$	Peak Repetive Reverse Voltage	30	V
$V_{RWM}$	Working Peak Reverse Voltage	30	V
$V_R$	DC Blocking Voltage	30	V
$I_{FM}$	Forward Continuous Current	200	mA
$I_{FSM}$	Peak forward current 9t=1us)	600	mA
$I_{FRM}$	Repetitive peak forward current	300	mA
$P_D$	Power Dissipation	200	mW
$T_J$	Junction Temperature	-55 to +125	°C
$T_{STG}$	Storage Temperature	-55 to +150	°C
$R_{\theta JA}$	Thermal Resistance From Junction To Ambient	635	°C/W

### Electrical Characteristics (Ta = 25 °C)

Symbol	Parameter	Conditions	Min	Max	Units
$V_{BR}$	Reverse Voltage	$I_F = 10\mu A$	30		V
$V_F$	Forward Voltage	$I_F = 0.1mA$		0.24	V
		$I_F = 1.0mA$		0.32	V
		$I_F = 10mA$		0.40	V
		$I_F = 30mA$		0.50	V
		$I_F = 100mA$		0.80	V
$I_R$	Reverse current	$V_R = 25V$		2	$\mu A$
$C_T$	Capacitance	$V_R = 1V, f = 1MHz$		10	pF
$t_{rr}$	Reverse Recovery Time	$I_{tr} = 10mA, I_R = 10mA \sim 1mA$		5	ns

### Ordering Information

Device	Package	Shipping	Tape wide	Emboss pitch	Tape specification	Notes
BAT54M5	SOD523	Tape & Reel 8000pcs /7" Reel	8 mm	4 mm	Conductive	

### Package Dimensions

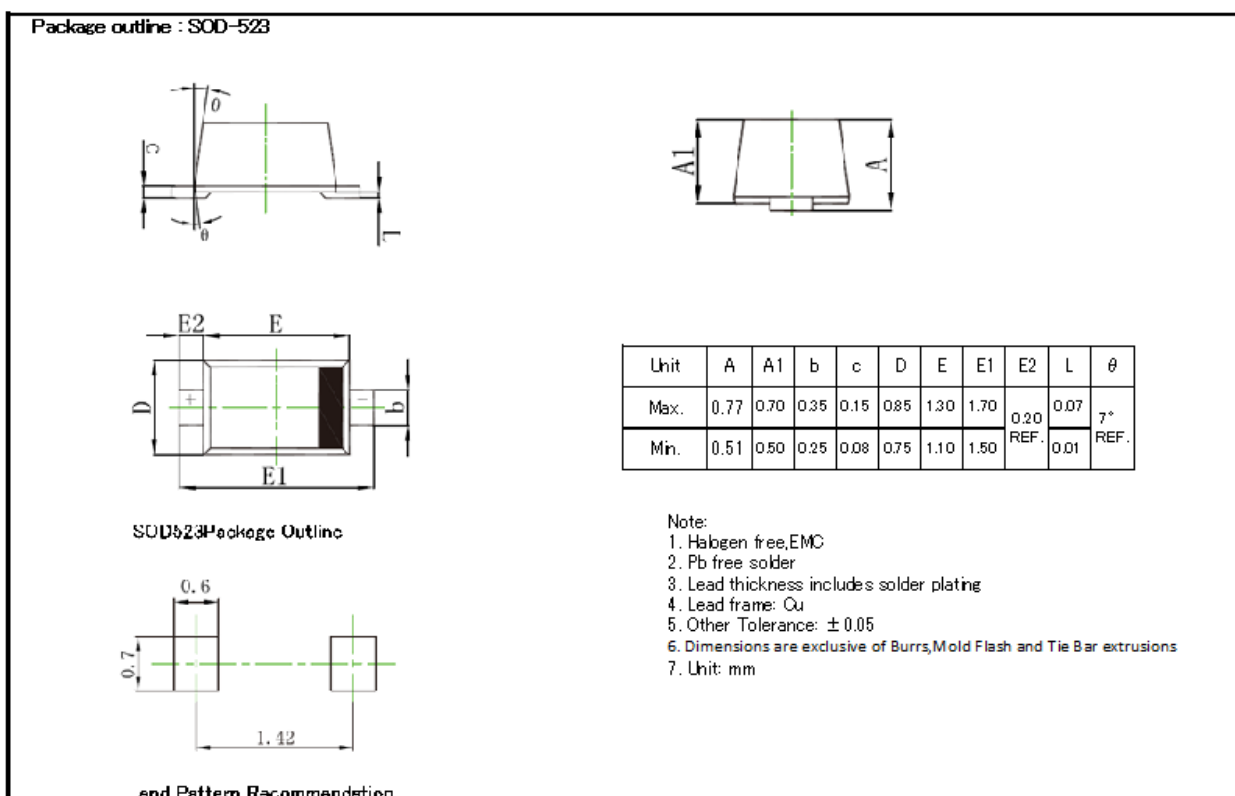

### NOTICE

AM'S PRODUCTS ARE NOT AUTHORIZED FOR USE AS COMPONENTS IN ANY LIFE SUPPORT DEVICES OR SYSTEMS.

AM reserve the right to make modifications, enhancements, improvements, corrections or other changes without further notice to any product herein. AM does not assume any liability arising out of the application or use of any product described herein.

## X-ON Electronics

Largest Supplier of Electrical and Electronic Components

*Click to view similar products for [Schottky Diodes & Rectifiers](#) category:*

*Click to view products by [amsem](#) manufacturer:*

Other Similar products are found below :

[MA4E2039](#) [MMBD301M3T5G](#) [RB160M-50TR](#) [D83C](#) [BAS16E6433HTMA1](#) [BAS 3010S-02LRH E6327](#) [BAT 54-02LRH E6327](#)  
[NRVBAF360T3G](#) [NSR05F40QNXT5G](#) [NTE555](#) [JANS1N6640](#) [SS3003CH-TL-E](#) [GA01SHT18](#) [CRS10I30A\(TE85L,QM](#) [MBRA140TRPBF](#)  
[MBRB30H30CT-1G](#) [BAT 15-04R E6152](#) [JANTX1N5712-1](#) [DMJ3940-000](#) [SB007-03C-TB-E](#) [NRVBB20100CTT4G](#) [NRVBM120LT1G](#)  
[NTSB30U100CT-1G](#) [CRG04\(T5L,TEMQ\)](#) [ACDBA1100LR-HF](#) [ACDBA1200-HF](#) [ACDBA240-HF](#) [ACDBA3100-HF](#) [CDBQC0530L-HF](#)  
[ACDBA260LR-HF](#) [ACDBA1100-HF](#) [10BQ015-M3/5BT](#) [NRVBM120ET1G](#) [VSSB410S-M3/5BT](#) [1N5819T-G](#) [PDS1040Q-13](#) [B160BQ-13-F](#)  
[SDM05U20CSP-7](#) [BAS 70-07 E6433](#) [B140S1F-7](#) [HSM560Je3/TR13](#) [DDB2265-000](#) [ZHCS506QTA](#) [HSM190Je3/TR13](#) [B330AF-13](#)  
[ACDBUC0230-HF](#) [SDM1U100S1F-7](#) [MBR10200CTF-G1](#) [CDLL5712](#) [DMF2822-000](#)