

# BAV19W THRU BAV21W

## SWITCHING DIODES

**VOLTAGE** 100~200 Volt **CURRENT** 0.2 Ampere

**SOD-123** Unit:mm

### FEATURES

- Fast Switching Speed
- For General Purpose Switching Applications
- Lead free in compliance with EU RoHS
- Marking code: BAV19W-A8,BAV20W-T2,BAV21W-T3

### MECHANICAL DATA

- Case Material: Molded Plastic.
- UL Flammability Classification Rating 94V-0

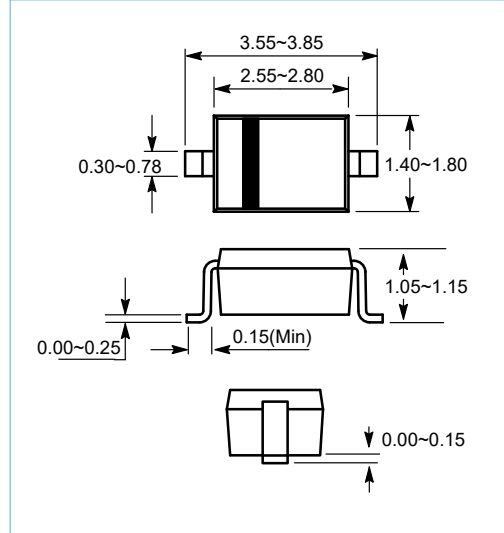
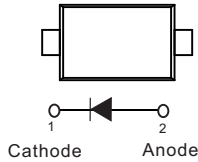

### MAXIMUM RATINGS AND ELECTRICAL CHARACTERISTICS( $T_A = 25^\circ\text{C}$ unless otherwise noted)

Symbol	meter	Value			Unit
		BAV19W	BAV20W	BAV21W	
$V_{RM}$	Non-Repetitive Peak Reverse Voltage	120	200	250	V
$V_{RRM}$	Peak Repetitive Reverse Voltage	100	150	200	V
$V_{RWM}$	Working Peak Reverse Voltage				
$V_{R(RMS)}$	RMS Reverse Voltage	71	106	141	V
$I_o$	Average Rectified Output Current	200			mA
$I_{FSM}$	Non-repetitive Peak Forward Surge Current @ $t=8.3\text{ms}$	2.0			A
$P_D$	Power Dissipation	500			mW
$R_{\theta JA}$	Thermal Resistance from Junction to Ambient	250			$^\circ\text{C}/\text{W}$
$T_j$	Junction Temperature	150			$^\circ\text{C}$
$T_{stg}$	Storage Temperature	-55~+150			$^\circ\text{C}$

### ELECTRICAL CHARACTERISTICS( $T_A = 25^\circ\text{C}$ unless otherwise noted)

Parameter	mbol	Test conditions	Min	Typ	Max	Unit
Reverse current	$I_R$	$V_R=100\text{V}$ BAV19W			0.1	uA
		$V_R=150\text{V}$ BAV20W			0.1	
		$V_R=200\text{V}$ BAV21W			0.1	
Forward voltage	$V_F$	$I_F=100\text{mA}$			1	V
		$I_F=200\text{mA}$			1.25	
Total capacitance	$C_{tot}$	$V_R=0\text{V}, f=1\text{MHz}$			5	pF
Reverse recovery time	$t_{rr}$	$I_F=I_R=30\text{mA}, I_{rr}=0.1*I_R, R_L=100\Omega$			50	ns

# BAV19W THRU BAV21W

## SWITCHING DIODES

### Typical Characteristics

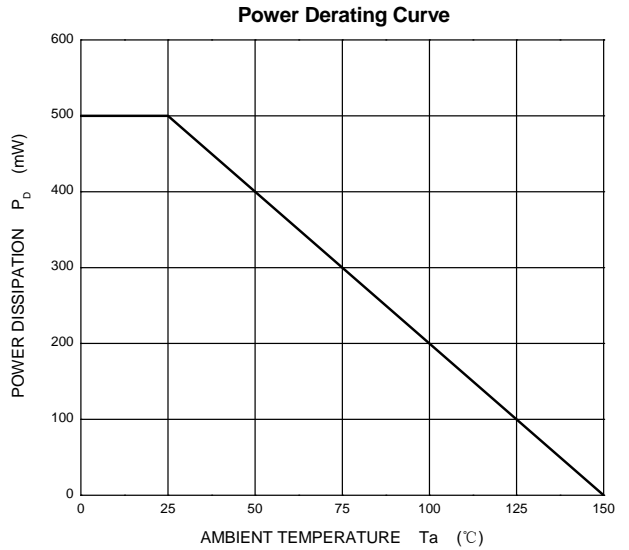
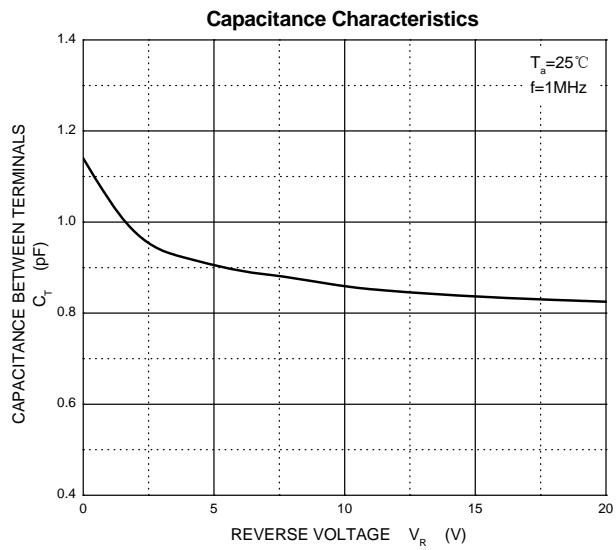
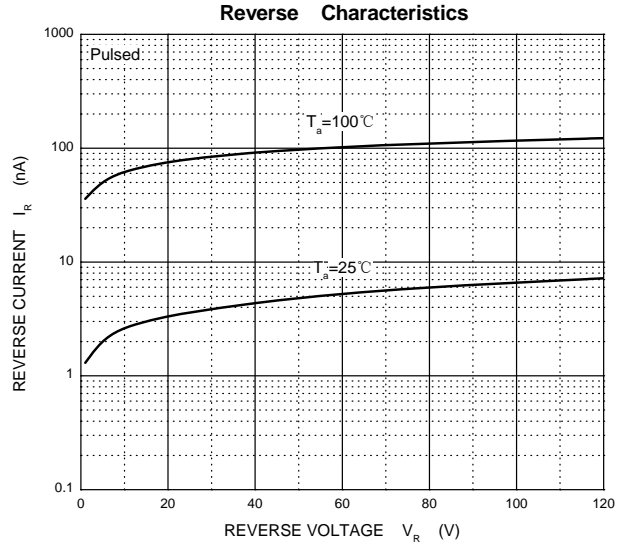
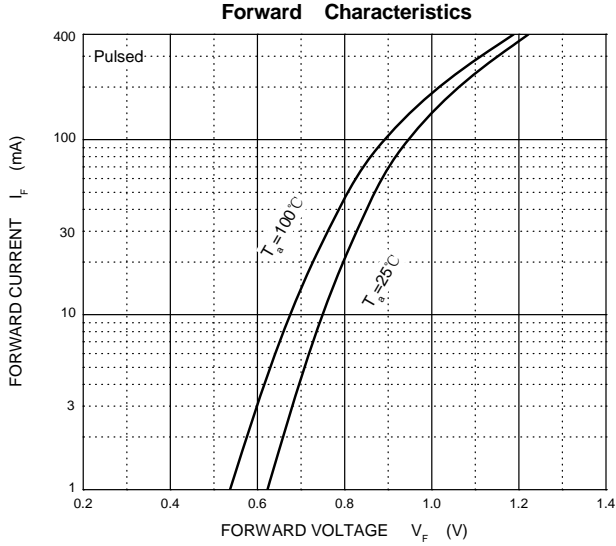

# BAV19W THRU BAV21W

---

## SWITCHING DIODES

### MOUNTING PAD LAYOUT

#### SOD-123

Unit:Inch(mm)

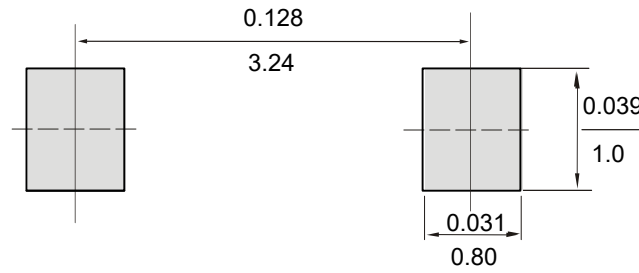

---

### ORDER INFORMATION

- Packing information

Part Number	Case	Reel Size	QUANTITY
BAV19W~BAV21W	SOD-123	7 Inch	3000

## X-ON Electronics

Largest Supplier of Electrical and Electronic Components

*Click to view similar products for [Diodes - General Purpose, Power, Switching category](#):*

*Click to view products by [amsem manufacturer](#):*

Other Similar products are found below :

[MMBD3004S-13-F](#) [1N3611](#) [NTE156A](#) [NTE6244](#) [1SS400CST2RA](#) [SDAA13](#) [SHN2D02FUTW1T1G](#) [1N4449](#) [1N456A](#) [1N914BTR](#)  
[D291S45T](#) [BAS 16-02L E6327](#) [BAS 16-02V H6327](#) [BAS 21U E6327](#) [BAS 28 E6327](#) [BAW56DWQ-7-F](#) [BAW75-TAP](#) [MM230L-CAA](#)  
[IDW40E65D1](#) [JAN1N3600](#) [JAN1N4454UR-1](#) [SMMSD4148T3G](#) [BYW95B/A52A](#) [NSVDAN222T1G](#) [CDSZC01100-HF](#) [BAV70HDW-7](#)  
[BAS28-7](#) [JANTX1N6640](#) [BAW56HDW-13](#) [BAS28 TR](#) [VS-HFA04SD60STR-M3](#) [1SS388-TP](#) [BAV99TQ-13-F](#) [BAV99HDW-13](#) [1N4004](#)  
[MMDB30-E28X](#) [LS4148](#) [IDV15E65D2](#) [W0503RH200S0L](#) [W0503SH200S0L](#) [M0268SJ200NLF](#) [M0268RJ200NLF](#) [S3MBF](#) [US1J](#)  
[DAN217U-TP](#) [SHV-06JNS-Q](#) [IDW30C65D1](#) [IDW80C65D1](#) [VS-HFA30TA60CSR-M3](#) [M1MA152WAT1](#)