

FEATURES

- 12 dB Gain
- 50 to 1000 MHz Frequency Range
- Noise Figure: 2.3 dB
- Single +5 V Supply
- Small SOT-89 Package
- RoHS Compliant/Lead-free

APPLICATIONS

- Low Noise Amplifier for CATV Set-Top Boxes
- CATV Drop Amplifier



PRODUCT DESCRIPTION

The ADA1200 is a highly linear amplifier developed to meet the stringent requirements of CATV systems. Offered in a low cost SOT-89 package, this GaAs MESFET design offers low noise and low distortion over a wide frequency range. The device is ideally

suited for applications as a Low Noise Amplifier in CATV Set-Top Boxes, and as a Drop Amplifier in CATV distribution systems. The ADA1200 requires a single +5 V supply, and typically consumes 400 mW of power.

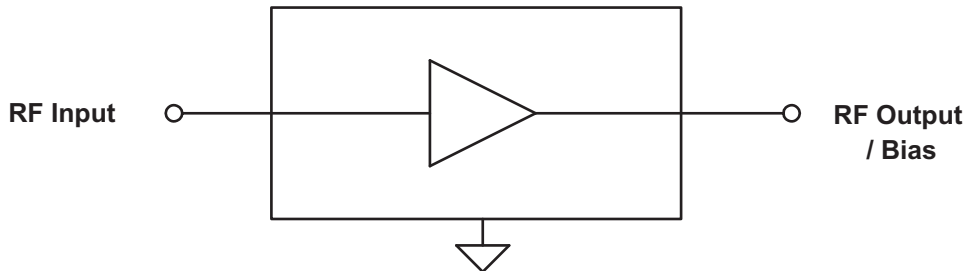

Figure 1: Block Diagram

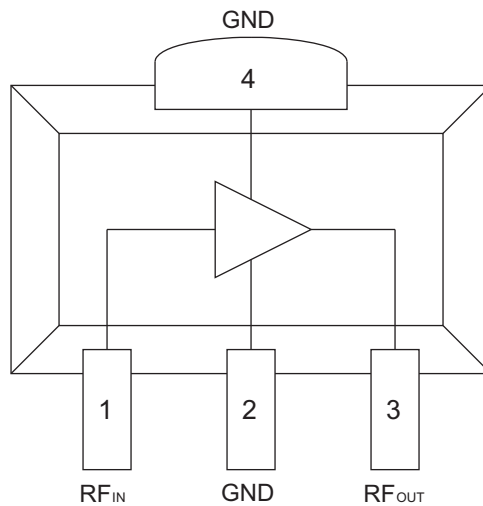

Figure 2: Pinout

Table 1: Pin Description

PIN	NAME	DESCRIPTION
1	RF _{IN}	RF INPUT
2	GND	Ground
3	RF _{OUT}	RF Output / Bias
4	GND	Ground

ELECTRICAL CHARACTERISTICS

Table 2: Absolute Minimum and Maximum Ratings

PARAMETER	MIN	MAX	UNIT
Device Voltage (V_{CC})	0	+9	VDC
RF Input Power (P_{IN})	-	+10	dBm
Storage Temperature (T_{STG})	-40	+150	°C
Channel Temperature	-	+150	°C

Stresses in excess of the absolute ratings may cause permanent damage. Functional operation is not implied under these conditions. Exposure to absolute ratings for extended periods of time may adversely affect reliability.

Table 3: Operating Ranges

PARAMETER	MIN	TYP	MAX	UNIT
RF Input/Output Frequency (f)	50	-	1000	MHz
Supply Voltage (V_{DD})	-	+5	-	VDC
Case Temperature (T_C)	-40	-	+100	°C

The device may be operated safely over these conditions; however, parametric performance is guaranteed only over the conditions defined in the electrical specifications.

Table 4: Electrical Specifications

($T_A = +25\text{ }^\circ\text{C}$, $V_{DD} = +5\text{ VDC}$, $f = 50\text{ to }860\text{ MHz}$, $75\text{ }\Omega$ system, ref. Figure 3)

PARAMETER	MIN	TYP	MAX	UNIT
Gain	10.5	12	13	dB
Noise Figure	-	2.3	3.5	dB
CSO ⁽¹⁾ Ch 5 & 6 (77.25 MHz & 83.25 MHz)	-	-	-57	dBc
CSO ⁽¹⁾ all other channels	-	-	-59	dBc
CTB ⁽¹⁾	-	-75	-64	dBc
XMOD ⁽¹⁾	-	-73	-63	dBc
OIP2 ⁽²⁾	+52	-	-	dBm
3-Tone OIP3 ⁽³⁾	+32	-	-	dBm
Input Return Loss	-	-25	-16	dB
Output Return Loss	-	-25	-16	dB
Thermal Resistance (θ_{JC})	-	-	50	$^\circ\text{C/W}$
Supply Current	-	80	100	mA

Notes:

- (1) 132 total channels, flat input; 110 analog channels @ +15 dBmV per channel; 22 digital channels (757.25 MHz to 871.25 MHz) @ 6 dB below analog channels; Standard NTSC channel plan (55.25 MHz to 871.25 MHz)
- (2) Two tones, -10 dBm per tone at input (439.25 MHz and 853.25 MHz); IMD_2 measured at 414.00 MHz.
- (3) Three tones, -10 dBm per tone at input (67.25, 439.25 MHz, 853.25 MHz); IMD_3 measured at 481.25 MHz (note that the related 2-tone IP3 is 3 dB higher than the 3-tone IP3).

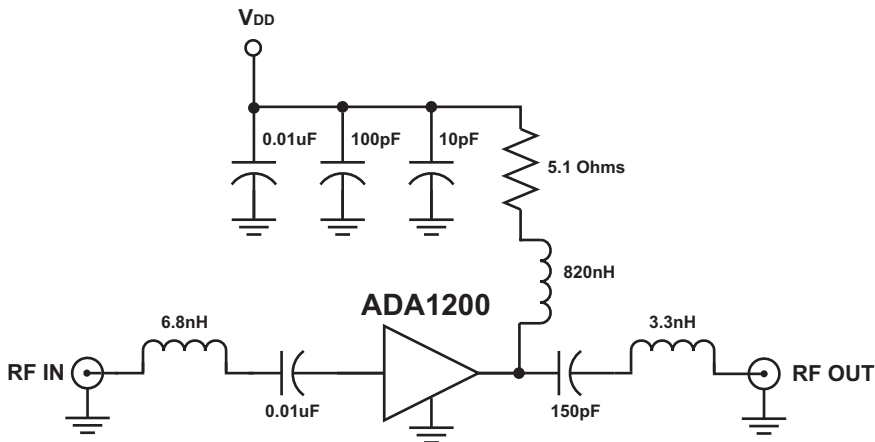

Figure 3: Test Circuit

PERFORMANCE DATA

Figure 4: Gain vs. Frequency
 ($T_A = +25\text{ }^\circ\text{C}$, $V_{DD} = +5\text{ V}$, $75\ \Omega$ System)

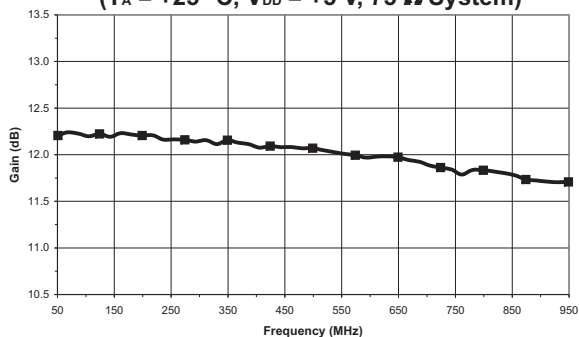

Figure 5: Noise Figure vs. Frequency
 ($T_A = +25\text{ }^\circ\text{C}$, $V_{DD} = +5\text{ V}$, $75\ \Omega$ System)

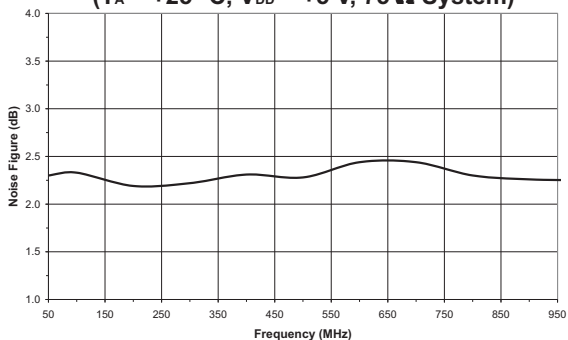

Figure 6: Input Return Loss vs. Frequency
 ($T_A = +25\text{ }^\circ\text{C}$, $V_{DD} = +5\text{ V}$, $75\ \Omega$ System)

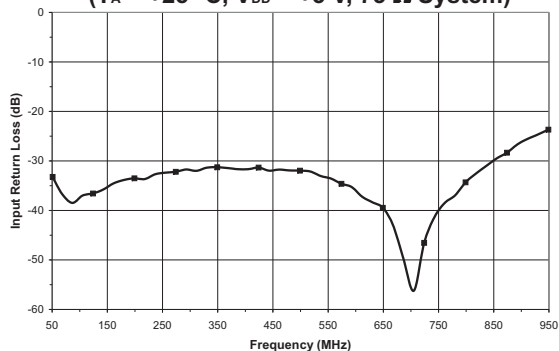

Figure 7: Output Return Loss vs. Frequency
 ($T_A = +25\text{ }^\circ\text{C}$, $V_{DD} = +5\text{ V}$, $75\ \Omega$ System)

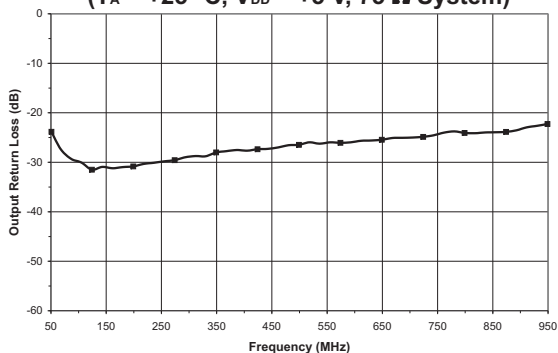

Figure 8: CTB vs. Frequency
 (TA = +25°C, VDD = +5 V, 132 analog channels,
 +15 dBmV input power per channel)

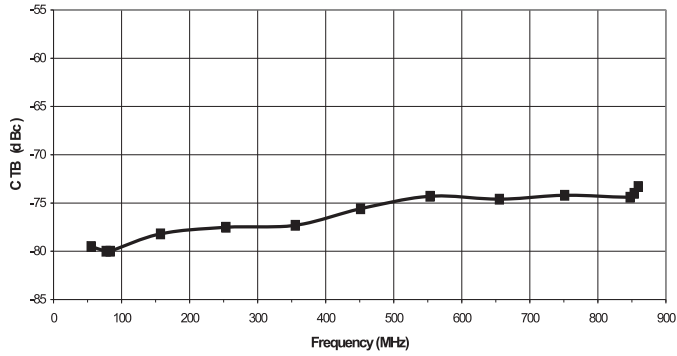

Figure 9: CSO vs. Frequency
 (TA = +25°C, VDD = +5 V, 132 analog channels,
 +15 dBmV input power per channel)

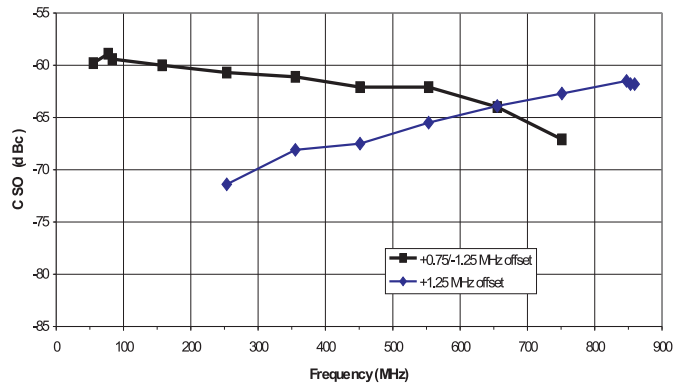
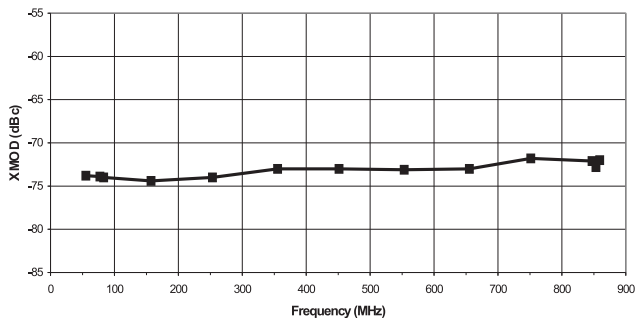

Figure 10: XMOD vs. Frequency
 (TA = +25°C, VDD = +5 V, 132 analog channels,
 +15 dBmV input power per channel)



APPLICATION INFORMATION

Table 5: In Circuit S-Parameters
 ($T_A = +25\text{ }^\circ\text{C}$, $V_{DD} = +5.0\text{ VDC}$, $75\ \Omega$ system, ref. Figure 3)

FREQ	S11		S21		S12		S22		K Factor
	MHz	DB	ANG	DB	ANG	DB	ANG	DB	
25	-17.8	-108.4	11.6	-140.4	-17.2	37.8	-13.0	-146.5	1.01
50	-31.1	-103.9	12.3	-171.3	-16.5	8.8	-23.9	-170.5	1.12
100	-37.9	-37.5	12.3	168.9	-16.5	-8.9	-30.2	-169.0	1.12
150	-35.8	-8.2	12.3	155.8	-16.5	-20.6	-31.0	-155.9	1.12
200	-35.2	-1.9	12.2	144.2	-16.6	-30.4	-30.6	-153.9	1.13
250	-33.6	-1.0	12.2	133.3	-16.6	-39.9	-30.1	-157.2	1.13
300	-32.7	-1.6	12.2	122.9	-16.7	-49.2	-29.1	-160.8	1.13
350	-31.9	-3.2	12.1	112.5	-16.7	-58.0	-28.0	-164.1	1.14
400	-32.0	-11.4	12.1	102.1	-16.7	-66.9	-27.4	-167.7	1.14
450	-32.8	-17.0	12.1	91.8	-16.8	-75.8	-27.0	-172.2	1.15
500	-33.2	-23.2	12.1	81.6	-16.8	-84.8	-26.3	-175.8	1.15
550	-35.9	-33.7	12.0	71.4	-16.9	-93.7	-26.3	-112.0	1.16
600	-40.1	-57.8	12.0	61.2	-17.0	-102.6	-25.7	124.4	1.16
650	-46.2	-113.4	12.0	50.8	-17.1	-111.6	-25.3	174.1	1.17
700	-38.1	145.8	11.9	40.5	-17.1	-121.3	-25.0	39.0	1.18
750	-31.0	127.6	11.8	30.0	-17.2	-129.9	-25.0	174.8	1.19
800	-28.2	117.1	11.8	20.1	-17.3	-138.1	-23.6	163.8	1.20
850	-25.0	107.3	11.7	9.6	-17.5	-147.6	-23.3	166.6	1.21
900	-22.4	97.7	11.7	-0.7	-17.5	-156.9	-23.2	167.7	1.22
950	-20.3	90.3	11.6	-11.4	-17.6	-166.0	-22.2	164.1	1.23
1000	-18.3	82.4	11.5	-22.1	-17.8	-175.6	-20.9	160.4	1.24

PACKAGE OUTLINE

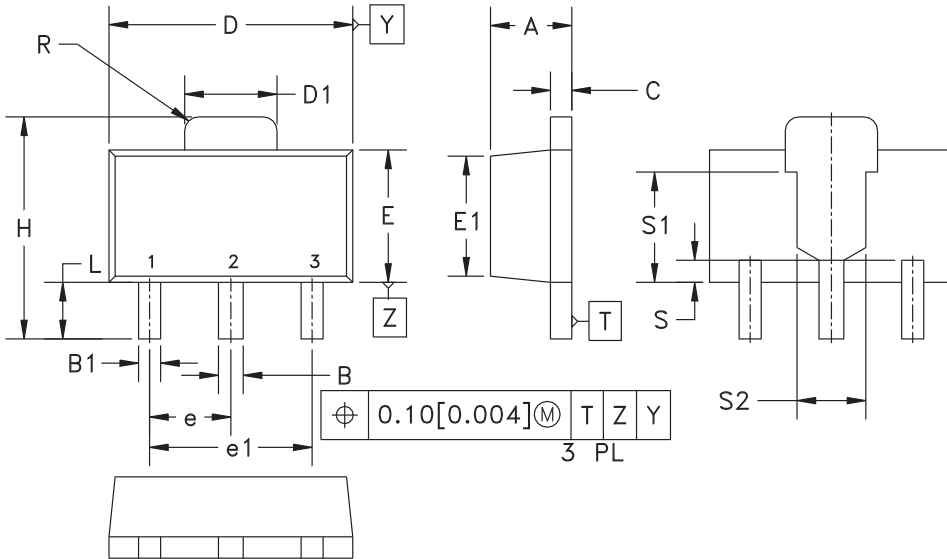

DIM.	MILLIMETERS		INCHES		NOTE
	MIN.	MAX.	MIN.	MAX.	
A	1.40	1.60	0.055	0.063	—
B	0.44	0.56	0.017	0.022	—
B ₁	0.36	0.48	0.014	0.019	3
C	0.35	0.44	0.014	0.017	—
D	4.40	4.60	0.173	0.181	—
D ₁	1.62	1.83	0.064	0.072	—
E	2.29	2.60	0.090	0.102	—
E ₁	2.13	2.29	0.084	0.090	4
e	1.50 BSC		0.059 BSC		—
e ₁	3.00 BSC		0.118 BSC		—
H	3.94	4.25	0.155	0.167	—
L	0.89	1.20	0.035	0.047	—
R	—	0.25	—	0.010	—
S	0.40 NOM.		0.016 NOM.		4
S ₁	2.03 NOM.		0.080 NOM.		4
S ₂	1.27 NOM.		0.050 NOM.		4

NOTES:

1. CONTROLLING DIMENSIONS: MILLIMETERS.
2. DIMENSIONS DO NOT INCLUDE END FLASH, MOLD FLASH OR MATERIAL PROTRUSIONS.
3. DIMENSION B₁, 2 PLACES.
4. DIMENSIONS E₁, S, S₁ & S₂ – REFERENCE ONLY.
5. REFERENCE JEDEC TO-243 (AA).

Figure 11: S24 Package Outline – SOT-89

TOP BRAND



NOTES:

1. ANADIGICS LOGO SIZE: X=0.040±0.010 Y=0.048±0.010
2. PART NUMBER: FOUR NUMERIC CHARACTERS
3. WAFER LOT NUMBER: LLLL= FOUR NUMERIC CHARACTERS
NN= TWO ALPHABETIC CHARACTERS
4. TYPE : ELITE
SIZE : 2-POINT
COLOR : LASER

Figure 12: Branding Specification

NOTES

ORDERING INFORMATION

PART NUMBER	TEMPERATURE RANGE	PACKAGE DESCRIPTION	COMPONENT PACKAGING
ADA1200GS24Q1	-40 to +100°C	SOT-89 Package	1,000 piece Tape and Reel

ANADIGICS, Inc.

141 Mount Bethel Road
 Warren, New Jersey 07059, U.S.A.
 Tel: +1 (908) 668-5000
 Fax: +1 (908) 668-5132

URL: <http://www.anadigics.com>
 E-mail: Mktg@anadigics.com

IMPORTANT NOTICE

ANADIGICS, Inc. reserves the right to make changes to its products or to discontinue any product at any time without notice. The product specifications contained in Advanced Product Information sheets and Preliminary Data Sheets are subject to change prior to a product's formal introduction. Information in Data Sheets have been carefully checked and are assumed to be reliable; however, ANADIGICS assumes no responsibilities for inaccuracies. ANADIGICS strongly urges customers to verify that the information they are using is current before placing orders.

WARNING

ANADIGICS products are not intended for use in life support appliances, devices or systems. Use of an ANADIGICS product in any such application without written consent is prohibited.

X-ON Electronics

Largest Supplier of Electrical and Electronic Components

Click to view similar products for [Video Amplifiers](#) category:

Click to view products by [Anadigics](#) manufacturer:

Other Similar products are found below :

[LT1193CN8](#) [NJW1351RB1-TE1](#) [MAX452ESA+](#) [5962-9313101M2A](#) [CGB7011-SC-0G00](#) [MAX9583AZT+T](#) [MAX5679ETJ+](#)
[MAX4312EEE+](#) [NJM592D8](#) [LT6552IDD#PBF](#) [LT1252CN8#PBF](#) [LT6559CUD#PBF](#) [LT1256CN#PBF](#) [AD8372ACPZ-R7](#)
[LT6553CGN#PBF](#) [LT1675CGN#PBF](#) [MAX454CPD+](#) [AD8145WYCPZ-R7](#) [ISL59110IEZ-T7](#) [LT1256CS#PBF](#) [LT1251CS#PBF](#)
[NJM2561F1-TE1](#) [ADA4856-3YCPZ-R7](#) [LT6552CDD#PBF](#) [LT1254CN#PBF](#) [LT1253CN8#PBF](#) [LT1675CMS8-1#PBF](#) [HMC3587LP3BETR](#)
[HMC453QS16GETR](#) [LM324AM](#) [5962-9313201MPA](#) [AD829SQ/883B](#) [AD8001ANZ](#) [AD8001AQ](#) [AD8001AR](#) [AD8001ARTZ-REEL7](#)
[AD8001ARZ](#) [AD8001ARZ-REEL7](#) [AD8013ARZ-14](#) [AD8023ARZ](#) [AD8072ARMZ](#) [AD8072JNZ](#) [AD8072JRZ](#) [AD8073JRZ](#) [AD810AN](#)
[AD810ANZ](#) [AD810ARZ](#) [AD810ARZ-REEL7](#) [AD810TRZ-EP](#) [AD811ANZ](#)