

FEATURES

- Mixed-Mode (HSPA, EV-DO) Compliant
- 4th Generation HELP™ technology
- High Efficiency (R99 waveform):
 - 41 % @ P_{OUT} = +28.2 dBm
 - 34 % @ P_{OUT} = +17.5 dBm
 - 21 % @ P_{OUT} = +13.5 dBm
 - 27 % @ P_{OUT} = +9 dBm
 - 13 % @ P_{OUT} = +3.5 dBm
- Low Quiescent Current: 2 mA
- Low Leakage Current in Shutdown Mode: <5 μA
- Internal Voltage Regulator
- Integrated “daisy chainable” directional coupler with CPL_{IN} and CPL_{OUT} port.
- Optimized for a 50 Ω System
- 1.8V Control Logic
- RoHS Compliant Package, 260 °C MSL-3

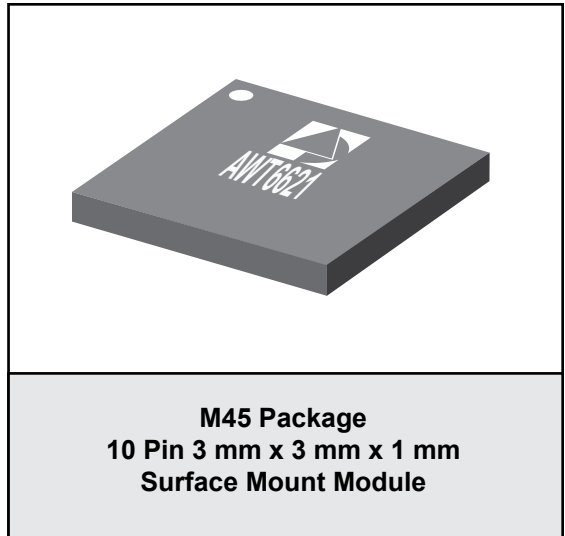

APPLICATIONS

- Band 1 (IMT) WCDMA/HSPA Wireless Devices
- Band Class 6 CDMA/EVDO Wireless Devices
- Band Class 6 EVDO Rev. B Wireless Devices

3 mm x 3 mm x 1 mm surface mount package incorporates matching networks optimized for output power, efficiency, and linearity in a 50 Ω system.

PRODUCT DESCRIPTION

The AWT6621 HELP4™ PA is a 4th generation HELP™ product for WCDMA devices operating in UMTS2100 (Band 1) and for CDMA devices operating in Band Class 6. This PA incorporates ANADIGICS’ HELP4™ technology to deliver exceptional efficiency at low power levels and low quiescent current without the need for external voltage regulators or converters. The device is manufactured using advanced InGaP-Plus™ HBT technology offering state-of-the-art reliability, temperature stability, and ruggedness. Three selectable bias modes that optimize efficiency for different output power levels and a shutdown mode with low leakage current increase handset talk and standby time. A “daisy chainable” directional coupler is integrated in the module, thus eliminating the need of an external coupler. The self-contained

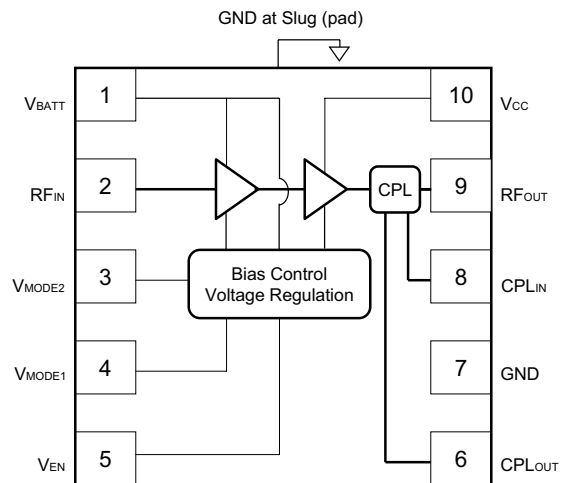

Figure 1: Block Diagram

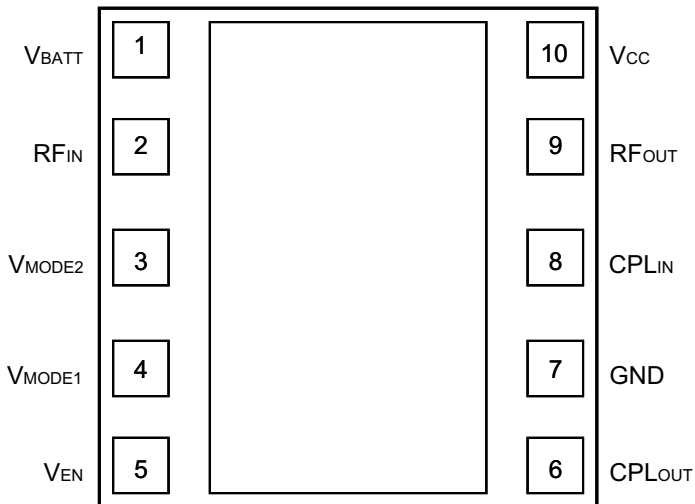

Figure 2: Pinout (X-ray Top View)

Table 1: Pin Description

PIN	NAME	DESCRIPTION
1	V _{BATT}	Battery Voltage
2	R _F _{IN}	RF Input
3	V _{MODE2}	Mode Control Voltage 2
4	V _{MODE1}	Mode Control Voltage 1
5	V _{EN}	PA Enable Voltage
6	C _{PL} _{OUT}	Coupler Output
7	GND	Ground
8	C _{PL} _{IN}	Coupler Input
9	R _F _{OUT}	RF Output
10	V _{CC}	Supply Voltage

ELECTRICAL CHARACTERISTICS

Table 2: Absolute Minimum and Maximum Ratings

PARAMETER	MIN	MAX	UNIT
Supply Voltage (V_{CC})	0	+5	V
Battery Voltage (V_{BATT})	0	+6	V
Control Voltages (V_{MODE1} , V_{MODE2} , V_{EN})	0	+3.5	V
RF Input Power (P_{IN})	-	+10	dBm
Storage Temperature (T_{STG})	-40	+150	°C

Stresses in excess of the absolute ratings may cause permanent damage. Functional operation is not implied under these conditions. Exposure to absolute ratings for extended periods of time may adversely affect reliability.

Table 3: Operating Ranges

PARAMETER	MIN	TYP	MAX	UNIT	COMMENTS
Operating Frequency (f)	1920	-	1980	MHz	
Supply Voltage (V_{CC})	+3.2	+3.4	+4.2	V	$P_{OUT} < +28.2$ dBm
Enable Voltage (V_{EN})	+1.35 0	+1.8 -	+3.1 +0.5	V	PA "on" PA "shut down"
Mode Control Voltage (V_{MODE1} , V_{MODE2})	+1.35 0	+1.8 -	+3.1 +0.5	V	Low Bias Mode High Bias Mode
WCDMA Output Power (UMTS) R99, HPM HSPA (MPR=0), HPM R99, MPM HSPA (MPR=0), MPM R99, LPM HSPA (MPR=0), LPM	27.7 ⁽¹⁾ 26.7 ⁽¹⁾ 17 16 9 8	28.2 27.2 17.5 16.5 9 8	- - - - - -	dBm	3GPP TS 34.121-1, Rel 8 Table C.11.1.3 for WCDMA SUBTEST 1
CDMA Output Power CDMA2000, HPM CDMA2000, MPM CDMA2000, LPM EVDO Rev. B, HPM	27.0 ⁽¹⁾ 16 8 -	27.5 16.5 8 18	- - - -	dBm	CDMA2000-RC1 3GPP2 C.S0033-B V1.0 5X Waveform
Case Temperature (T_C)	-30	-	+90	°C	

The device may be operated safely over these conditions; however, parametric performance is guaranteed only over the conditions defined in the electrical specifications.

Notes:

(1) For operation at 3.2 V, P_{OUT} is derated by 0.5 dB.

Table 4: Electrical Specifications - WCDMA Operation (R99 waveform)
(T_C = +25 °C, V_{CC} = +3.4 V, V_{BATT} = +3.4 V, V_{EN} = +1.8 V, 50 Ω system)

PARAMETER	MIN	TYP	MAX	UNIT	COMMENTS		
					P _{OUT}	V _{MODE1}	V _{MODE2}
Gain	24 15 7	26.5 18 9.5	29 21 12	dB	+28.2 dBm +17.5 dBm +9 dBm	0 V 1.8 V 1.8 V	0 V 0 V 1.8 V
ACLR1 at 5 MHz offset ⁽¹⁾	- - -	-41 -41 -42	-37.5 -37.5 -37.5	dBc	+28.2 dBm +17.5 dBm +9 dBm	0 V 1.8 V 1.8 V	0 V 0 V 1.8 V
ACLR2 at 10 MHz offset	- - -	-54 -56 -56	-48 -48 -48	dBc	+28.2 dBm +17.5 dBm +9 dBm	0 V 1.8 V 1.8 V	0 V 0 V 1.8 V
Power-Added Efficiency ⁽¹⁾	36 28 - 22 -	41 34 21 27 13	- - - - -	%	+28.2 dBm +17.5 dBm +13.5 dBm +9 dBm +3.5 dBm	0 V 1.8 V 1.8 V 1.8 V 1.8 V	0 V 0 V 0 V 1.8 V 1.8 V
Quiescent Current (I _q) Low Bias Mode	-	2	3.5	mA	through V _{CC} pin	1.8 V	1.8 V
Mode Control Current	-	0.08	0.15	mA	through V _{MODE} pins, V _{MODE1,2} = +1.8 V		
Enable Current	-	0.04	0.1	mA	through V _{EN} pin, V _{EN} = 1.8 V		
BATT Current	-	0.8	1.5	mA	through V _{BATT} pin, V _{MODE1,2} = +1.8 V		
Leakage Current	-	<5	8	μA	V _{BATT} = +4.2 V, V _{CC} = +4.2 V, V _{EN} = 0 V, V _{MODE1,2} = 0 V		
Noise Power	- - -	-135 -138 -144	-133 -136 -141	dBm/Hz	2110 MHz to 2170 MHz GPS Band ISM Band		
Harmonics 2fo 3fo, 4fo	- - -	-43 -46	-35 -38	dBc	P _{OUT} < +28.2 dBm		
Coupling Factor	-	19.5	-	dB			
Directivity	-	20	-	dB			
Coupler IN_OUT Daisy Chain Insertion Loss	-	<0.25	-	dB	698 MHz through 2620 MHz PIN 8 through 9 SHUTDOWN mode		
Spurious Output Level (all spurious outputs)	-	-	-70	dBc	P _{OUT} < +28.2 dBm In-band load VSWR < 5:1 Out-of-band load VSWR < 10:1 Applies over all operating conditions		
Load mismatch stress with no permanent degradation or failure	8:1	-	-	VSWR	Applies over full operating range		

Notes:

(1) ACLR and Efficiency measured at 1950 MHz.

Table 5: Electrical Specifications - CDMA Operation (CDMA2000, RC-1)
(T_C = +25 °C, V_{BATT} = V_{CC} = +3.4 V, V_{ENABLE} = +1.8 V, 50 Ω system)

PARAMETER	MIN	TYP	MAX	UNIT	COMMENTS		
					P _{OUT}	V _{MODE1}	V _{MODE2}
Gain	24 15 7	26.5 18 9	29 21 12	dB	+27.5 dBm +16.5 dBm +8 dBm	0 V 1.8 V 1.8 V	0 V 0 V 1.8 V
Adjacent Channel Power at +1.25 MHz offset Primary Channel BW - 1.23 MHz Adjacent Channel BW = 30 kHz	- - -	-50 -53 -55	-46.5 -46.5 -46.5	dBc	+27.5 dBm +16.5 dBm +8 dBm	0 V 1.8 V 1.8 V	0 V 0 V 1.8 V
Adjacent Channel Power at +1.98 MHz Primary Channel BW=1.23 MHz Adjacent Channel BW=30 kHz	- - -	-55 -59 -58	-53 -53 -53	dBc	+27.5 dBm +16.5 dBm +8 dBm	0 V 1.8 V 1.8 V	0 V 0 V 1.8 V
Power-Added Efficiency ⁽¹⁾	34 27 20	38 31 24	- - -	%	+27.5 dBm +16.5 dBm +8 dBm	0 V 1.8 V 1.8 V	0 V 0 V 1.8 V
Spurious Output Level (all spurious outputs)	-	-	-70	dBc	See Note 2		
Load mismatch stress with no permanent degradation or failure	8:1	-	-	VSWR	Applies over full operating range		

Notes:

(1) ACLR and Efficiency measured at 1950 MHz.

(2) P_{OUT} < +27.5 dBm, In-Band VSWR < 5:1, Out-Of-Band VSWR < 10:1. Applies to all operating conditions.

Table 6: Electrical Specifications - EVDO Rev. B Operation
(T_C = +25 °C, V_{BATT} = V_{CC} = +3.4 V, V_{ENABLE} = +1.8 V, 50 Ω system, [10001] or [10101] Waveform)

PARAMETER	MIN	TYP	MAX	UNIT	COMMENTS		
					P _{OUT}	V _{MODE1}	V _{MODE2}
Spurious in PHS Band (1884.5 - 1919.6 MHz)	-	-45	-41	dBm/300KHz	+18 dBm	0 V	0V
Intermodulation IM3	-	-23	-13	dBm/MHz	+18 dBm	0 V	0V

APPLICATION INFORMATION

To ensure proper performance, refer to all related Application Notes on the ANADIGICS web site: <http://www.anadigics.com>

Shutdown Mode

The power amplifier may be placed in a shutdown mode by applying logic low levels (see Operating Ranges table) to the V_{EN} , V_{MODE1} and V_{MODE2} voltages.

Bias Modes

The power amplifier may be placed in either Low, Medium or High Bias modes by applying the appropriate logic level (see Operating Ranges table)

to the V_{MODE} pins. The Bias Control table below lists the recommended modes of operation for various applications.

Three operating modes are recommended to optimize current consumption. High Bias/High Power operating mode is for P_{OUT} levels ≥ 16 dBm. At ~ 17 dBm - 8 dBm, the PA could be switched to Medium Power Mode. For P_{OUT} levels ≤ -8 dBm, the PA could be switched to Low Power Mode for extremely low current consumption.

Table 7: Bias Control

APPLICATION	P_{OUT} LEVELS	BIAS MODE	V_{EN}	V_{MODE1}	V_{MODE2}	V_{CC}	V_{BATT}
Low power (Low Bias Mode)	< +9 dBm	Low	+1.8 V	+1.8 V	+1.8 V	3.2 - 4.2 V	> 3.2 V
Med power (Medium Bias Mode)	> 8 dBm < + 17.5 dBm	Low	+1.8 V	+1.8 V	0 V	3.2 - 4.2 V	> 3.2 V
High power (High Bias Mode)	> +16 dBm	High	+1.8 V	0 V	0 V	3.2 - 4.2 V	> 3.2 V
Shutdown	-	Shutdown	0 V	0 V	0 V	3.2 - 4.2 V	> 3.2 V

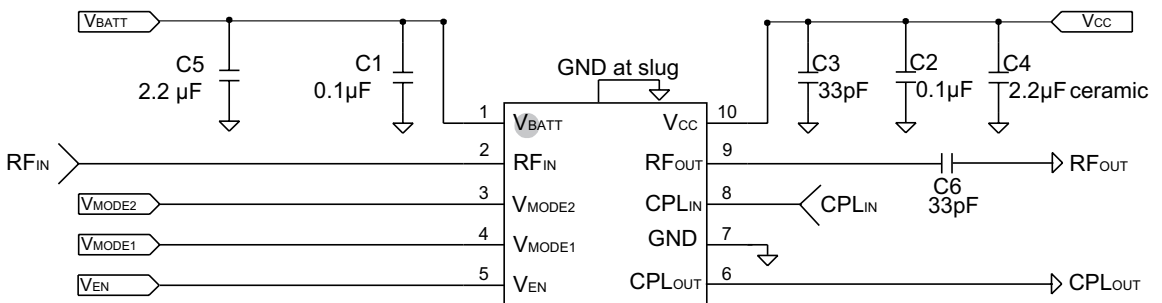
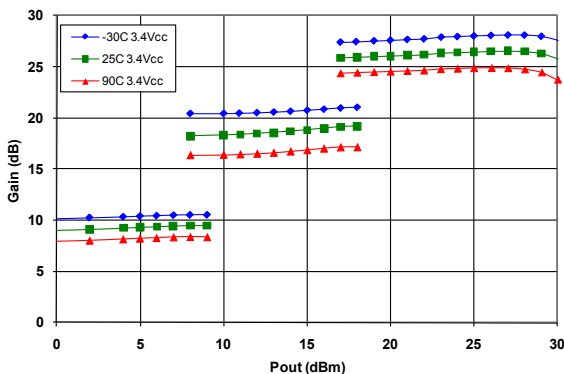

Figure 3: Evaluation Board Schematic

**PERFORMANCE DATA PLOTS:
(R99 Waveform at 1950 MHz and 50 Ω system)**

**Figure 4: WCDMA Gain (dB) over Temperature
($V_{batt} = V_{cc} = 3.4\text{ V}$)**



**Figure 5: WCDMA Gain (dB) over Voltage
($T_c = 25\text{ °C}$)**

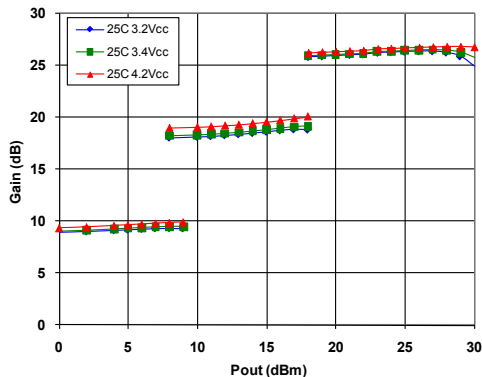

**Figure 6: WCDMA PAE (%) over Temperature
($V_{batt} = V_{cc} = 3.4\text{ V}$)**

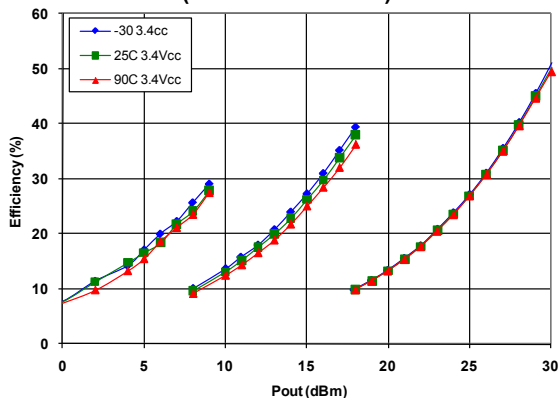

**Figure 7: WCDMA PAE (%) over Voltage
($T_c = 25\text{ °C}$)**

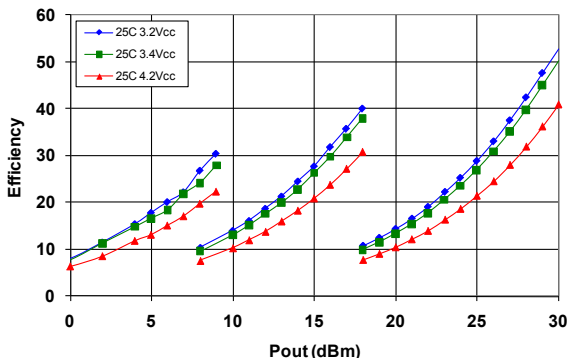

**Figure 8: WCDMA ACLR1 (dBc) over Temperature
($V_{batt} = V_{cc} = 3.4\text{ V}$)**

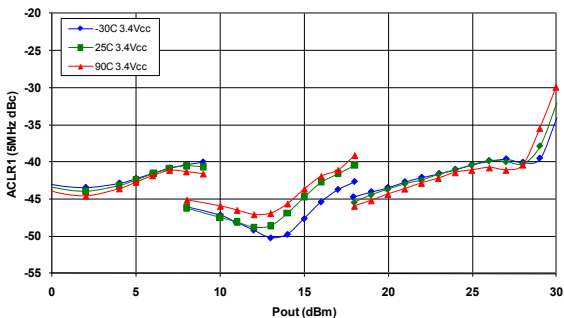

**Figure 9: WCDMA ACLR1 (dBc) over Voltage
($T_c = 25\text{ °C}$)**

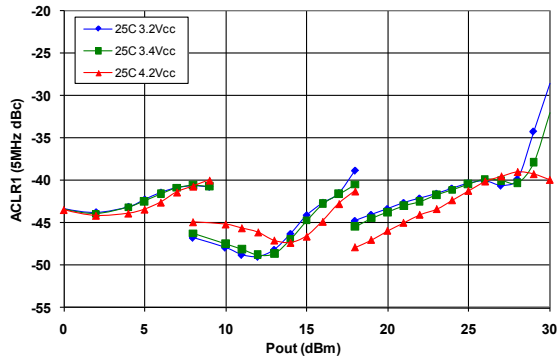

PACKAGE OUTLINE

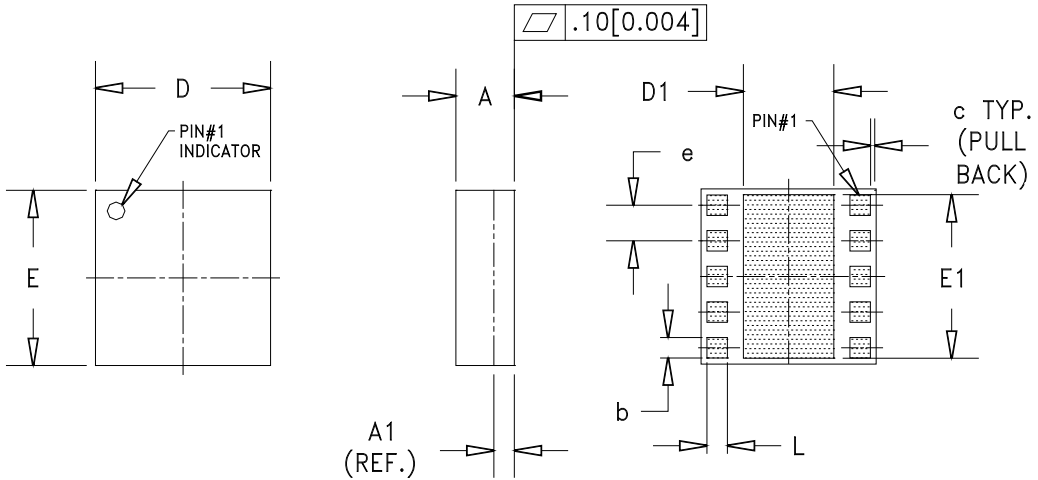

SYMBOL	MILLIMETERS			INCHES			NOTE
	MIN.	NOM.	MAX.	MIN.	NOM.	MAX.	
A	0.91	1.03	1.13	0.035	0.041	0.044	—
A1	PLEASE REFER TO LAMINATE CONTROL DRAWING						—
b	0.32	0.35	0.40	0.013	0.014	0.016	3
c	—	0.10	—	—	0.004	—	—
D	2.88	3.00	3.12	0.113	0.118	0.123	—
D1	1.45	1.50	1.57	0.057	0.059	0.062	3
E	2.88	3.00	3.12	0.113	0.118	0.123	—
E1	2.70	2.75	2.85	0.106	0.108	0.112	3
e	—	0.60	—	—	0.024	—	3
L	0.32	0.35	0.40	0.013	0.014	0.016	3

NOTES:

1. CONTROLLING DIMENSIONS: MILLIMETERS
2. UNLESS SPECIFIED TOLERANCE=±0.076[0.003].
3. PADS (INCLUDING CENTER) SHOWN UNIFORM SIZE FOR REFERENCE ONLY. ACTUAL PAD SIZE AND LOCATION WILL VARY WITHIN MIN. AND MAX. DIMENSIONS ACCORDING TO SPECIFIC LAMINATE DESIGN.
4. UNLESS SPECIFIED DIMENSIONS ARE SYMMETRICAL ABOUT CENTER LINES SHOWN.
5. LAMINATE CONTROL DRAWING SPECIFIED BY PART NUMBER.

Figure 10: M45 Package Outline - 10 Pin 3 mm x 3 mm x 1 mm Surface Mount Module

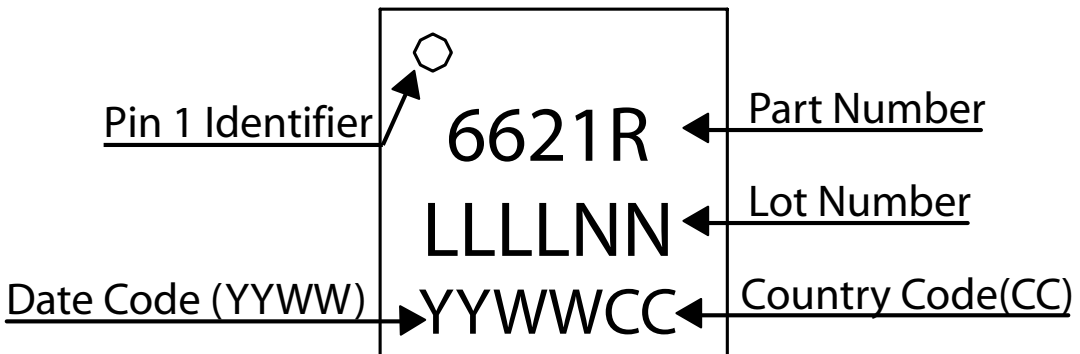
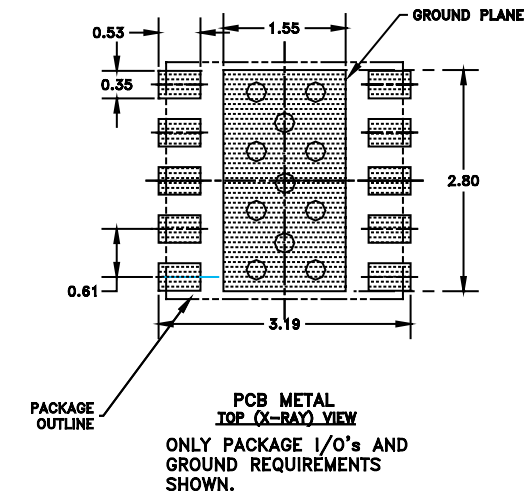

Figure 11: Branding Specification - M45 Package

PCB AND STENCIL DESIGN GUIDELINE



NOTES:

- (1) OUTLINE DRAWING REFERENCE:
P8002478_E
- (2) UNLESS SPECIFIED DIMENSIONS
ARE SYMMETRICAL ABOUT CENTER
LINES SHOWN.
- (3) DIMENSIONS IN MILLIMETERS.
- (4) VIAS SHOWN IN PCB METAL VIEW
ARE FOR REFERENCE ONLY.
NUMBER & SIZE OF THERMAL VIAS
REQUIRED DEPENDENT ON HEAT
DISSIPATION REQUIREMENT AND THE
PCB PROCESS CAPABILITY.
- (5) RECOMMENDED STENCIL THICKNESS:
APPROX. 0.150mm (6 Mils)

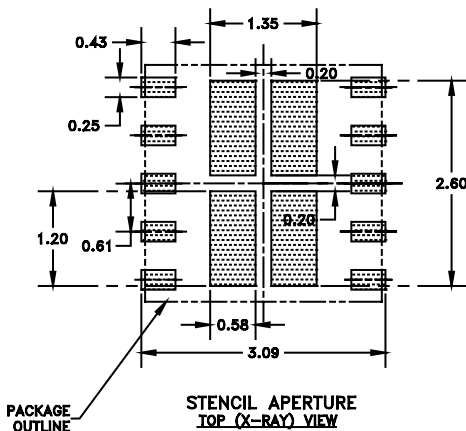
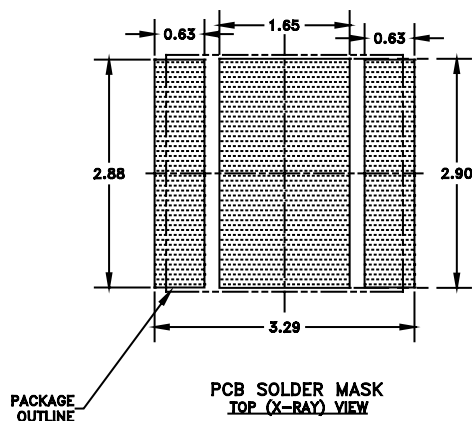
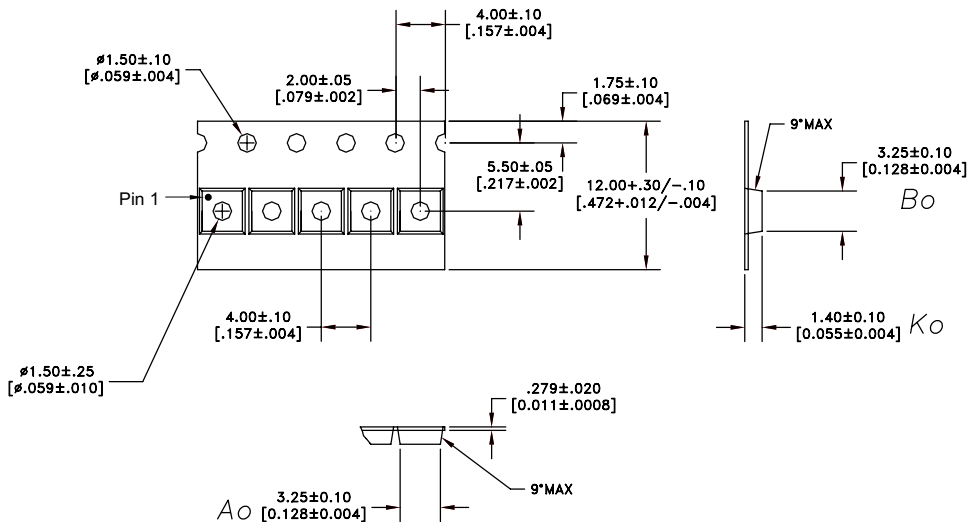

Figure 12: Recommended PCB Layout Information

COMPONENT PACKAGING



NOTES:

- 1. MATERIAL: 3000 (CARBON FILLED POLYCARBONATE)
100% RECYCLABLE.

DIMENSIONS ARE IN MILLIMETERS [INCHES]

DIMENSIONING AND TOLERANCING PER ASME Y14.5M-1994

Figure 13: Carrier Tape

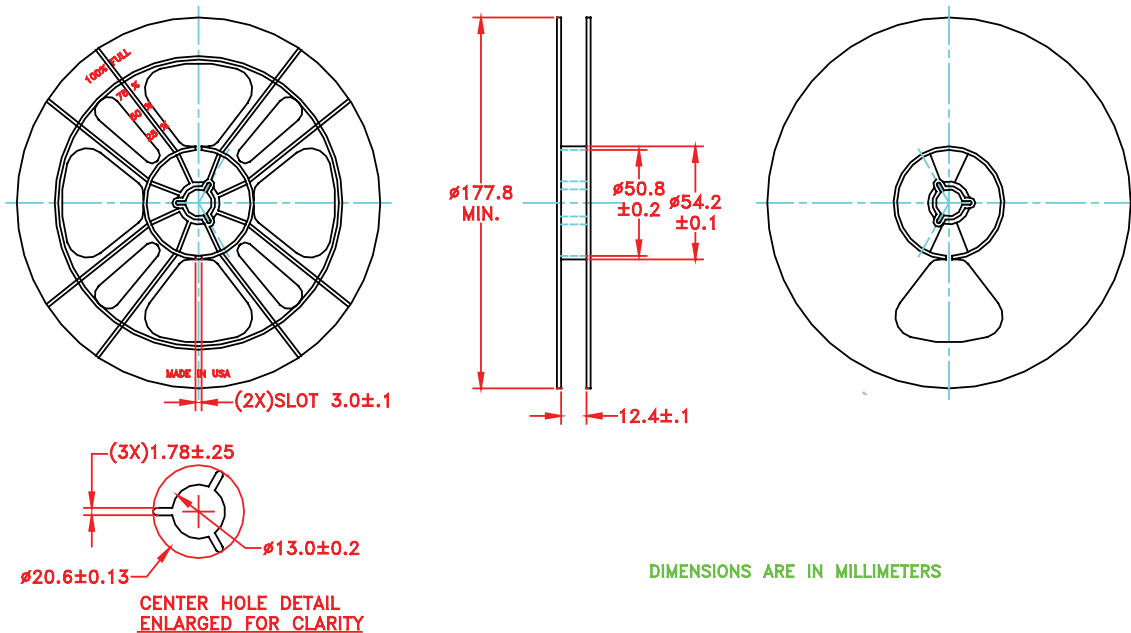

DIMENSIONS ARE IN MILLIMETERS

NOTES:

- 1. MATERIAL: BLACK CARBON POLYSTYRENE
- SURFACE RESISTIVITY: 1×10^4 TO 1×10^8 ohms/square

DIMENSIONING AND TOLERANCING PER ASME Y14.5M-1994

Figure 14: Reel

ORDERING INFORMATION

ORDER NUMBER	TEMPERATURE RANGE	PACKAGE DESCRIPTION	COMPONENT PACKAGING
AWT6621RM45Q7	-30 °C to +90 °C	RoHS Compliant 10 Pin 3 mm x 3 mm x 1 mm Surface Mount Module	Tape and Reel, 2500 pieces per Reel
AWT6621RM45P9	-30 °C to +90 °C	RoHS Compliant 10 Pin 3 mm x 3 mm x 1 mm Surface Mount Module	Partial Tape and Reel

**ANADIGICS, Inc.**

141 Mount Bethel Road

Warren, New Jersey 07059, U.S.A.

Tel: +1 (908) 668-5000

Fax: +1 (908) 668-5132

URL: <http://www.anadigics.com>**IMPORTANT NOTICE**

ANADIGICS, Inc. reserves the right to make changes to its products or to discontinue any product at any time without notice. The product specifications contained in Advanced Product Information sheets and Preliminary Data Sheets are subject to change prior to a product's formal introduction. Information in Data Sheets have been carefully checked and are assumed to be reliable; however, ANADIGICS assumes no responsibilities for inaccuracies. ANADIGICS strongly urges customers to verify that the information they are using is current before placing orders.

WARNING

ANADIGICS products are not intended for use in life support appliances, devices or systems. Use of an ANADIGICS product in any such application without written consent is prohibited.

X-ON Electronics

Largest Supplier of Electrical and Electronic Components

Click to view similar products for [Amplifier IC Development Tools](#) category:

Click to view products by [Anadigics](#) manufacturer:

Other Similar products are found below :

[EVAL-ADCMP562BRQZ](#) [EVAL-ADCMP565BPZ](#) [EVAL-ADCMP566BCPZ](#) [EVAL-ADCMP607BCPZ](#) [EVAL-ADM1191EBZ](#) [EVAL-
HSOPAMP-1CPZ](#) [125932-HMC874LC3C](#) [AD8003ACP-EBZ](#) [AD8013AR-14-EBZ](#) [AD8033AKS-EBZ](#) [AD8040AR-EBZ](#) [AD8044AR-EBZ](#)
[AD8129AR-EBZ](#) [AD8225-EVALZ](#) [ADA4853-3YRU-EBZ](#) [ADA4859-3ACP-EBZ](#) [ADA4861-3YR-EBZ](#) [ADA4862-3YR-EBZ](#) [ADA4891-
3AR-EBZ](#) [ADA4950-2YCP-EBZ](#) [DEM-OPA-SOT-1B](#) [OPA653EVM](#) [LMH6553SDEVAL/NOPB](#) [EVAL-ADCMP561BRQZ](#) [AD744JR-EBZ](#)
[AD8004AR-EBZ](#) [AD8023AR-EBZ](#) [AD8030ARJ-EBZ](#) [AD8039ART-EBZ](#) [AD8040ARU-EBZ](#) [AD8054AR-EBZ](#) [AD8073JR-EBZ](#)
[AD813AR-14-EBZ](#) [AD8232-EVALZ](#) [AD8304-EVALZ](#) [AD8335-EVALZ](#) [AD8336-EVALZ](#) [AD848JR-EBZ](#) [ADA4850-2YCP-EBZ](#)
[ADA4853-2YCP-EBZ](#) [ADA4858-3ACP-EBZ](#) [ADA4922-1ACP-EBZ](#) [ADCMP380-EVALZ](#) [ADL5390-EVALZ](#) [THS4513EVM](#)
[THS7347EVM](#) [551600075-001/NOPB](#) [551600083-001/NOPB](#) [BUF12840EVM](#) [DEM-OPA-SO-2E](#)