

Micropower Voltage Reference

FEATURES

- **Guaranteed** $\pm 4\text{mV}$ Initial Accuracy LT1004-1.2
- **Guaranteed** $\pm 20\text{mV}$ Accuracy LT1004-2.5
- **Guaranteed** $10\mu\text{A}$ Operating Current
- **Guaranteed** Temperature Performance
- Operates up to 20mA
- Very Low Dynamic Impedance

APPLICATIONS

- Portable Meter References
- Portable Test Instruments
- Battery-Operated Systems
- Current Loop Instrumentation

DESCRIPTION

The **LT[®]1004** micropower voltage reference is a 2-terminal bandgap reference diode designed to provide high accuracy and excellent temperature characteristics at very low operating currents. Optimization of the key parameters in the design, processing and testing of the device results in accuracy specifications previously attainable only with selected units. Below is a distribution plot of reference voltage for a typical lot of LT1004-1.2. Virtually all of the units fall well within the prescribed limits of $\pm 4\text{mV}$.

The LT1004 is a pin-for-pin replacement for the LM185/LM385 series of references with improved accuracy specifications. More important, the LT1004 is an attractive device for use in systems where accuracy was previously obtained at the expense of power consumption and trimming.

For a low drift micropower reference with guaranteed temperature coefficient, see the LT1034 data sheet.

LT, LT, LTC, LTM, Linear Technology and the Linear logo are registered trademarks of Analog Devices, Inc. All other trademarks are the property of their respective owners.

TYPICAL APPLICATION

Micropower Cold Junction Compensation for Thermocouples

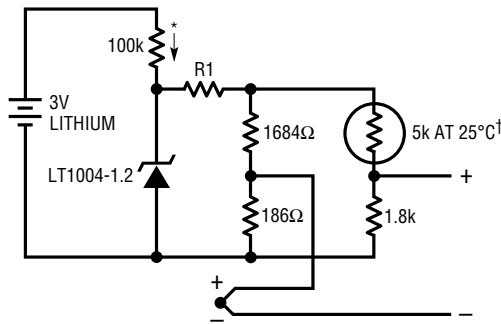

| THERMOCOUPLE TYPE | R1 |
|-------------------|------|
| J | 233k |
| K | 299k |
| T | 300k |
| S | 2.1M |

* QUIESCENT CURRENT $\approx 15\text{A}$
 † YELLOW SPRINGS INST. CO. PART #44007
 COMPENSATES WITHIN $\pm 1^\circ\text{C}$ FROM 0°C TO 60°C

1004 TA01

Typical Distribution of Reference Voltage (LT1004-1.2)

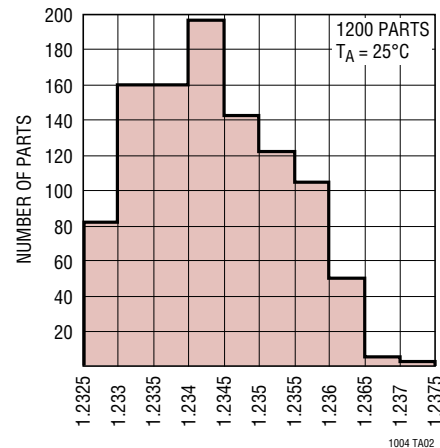

LT1004

ABSOLUTE MAXIMUM RATINGS

(Note 1)

| | | | |
|--|----------------|-----------------------------|----------------|
| Reverse Breakdown Current | 30mA | Operating Temperature Range | |
| Forward Current | 10mA | LT1004M | -55°C to 125°C |
| Storage Temperature Range | -65°C to 150°C | LT1004I | -40°C to 85°C |
| Lead Temperature (Soldering, 10 sec) | 300°C | LT1004C | 0°C to 70°C |

PIN CONFIGURATION

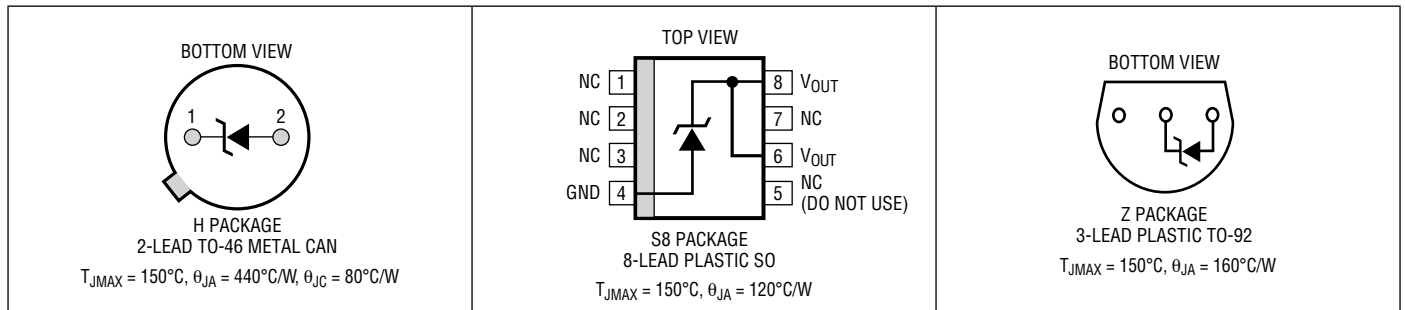

ORDER INFORMATION <http://www.linear.com/product/LT1004#orderinfo>

| LEAD FREE FINISH | TAPE AND REEL | PART MARKING | PACKAGE DESCRIPTION | TEMPERATURE RANGE |
|-------------------|---------------------|--------------|------------------------|-------------------|
| LT1004MH-2.5#PBF | LT1004MH-2.5#TRPBF | | 2-Lead TO-46 Metal Can | -55°C to 125°C |
| LT1004CS8-1.2#PBF | LT1004CS8-1.2#TRPBF | 0412 | 8-Lead Plastic SO | 0°C to 70°C |
| LT1004CS8-2.5#PBF | LT1004CS8-2.5#TRPBF | 0425 | 8-Lead Plastic SO | 0°C to 70°C |
| LT1004IS8-1.2#PBF | LT1004IS8-1.2#TRPBF | 0412I | 8-Lead Plastic SO | -40°C to 85°C |
| LT1004IS8-2.5#PBF | LT1004IS8-2.5#TRPBF | 0425I | 8-Lead Plastic SO | -40°C to 85°C |
| LT1004CZ-1.2#PBF | LT1004CZ-1.2#TRPBF | | 3-Lead Plastic TO-92 | 0°C to 70°C |
| LT1004CZ-2.5#PBF | LT1004CZ-2.5#TRPBF | | 3-Lead Plastic TO-92 | 0°C to 70°C |
| LT1004IZ-1.2#PBF | LT1004IZ-1.2#TRPBF | | 3-Lead Plastic TO-92 | -40°C to 85°C |
| LT1004IZ-2.5#PBF | LT1004IZ-2.5#TRPBF | | 3-Lead Plastic TO-92 | -40°C to 85°C |

Consult LTC Marketing for parts specified with wider operating temperature ranges.

For more information on lead free part marking, go to: <http://www.linear.com/leadfree/>

For more information on tape and reel specifications, go to: <http://www.linear.com/tapeandreel/>. Some packages are available in 500 unit reels through designated sales channels with #TRMPBF suffix.

ELECTRICAL CHARACTERISTICS The ● denotes the specifications which apply over the full operating temperature range, otherwise specifications are at $T_A = 25^\circ\text{C}$.

| SYMBOL | PARAMETER | CONDITIONS | C, I SUFFIXES | | | H SUFFIX | | | UNITS |
|---|---|---|---------------|-------|-------|----------|-------|-----------------------|-------|
| | | | MIN | TYP | MAX | MIN | TYP | MAX | |
| V_Z | Reverse Breakdown Voltage | $I_R = 100\mu\text{A}$ | 1.231 | 1.235 | 1.239 | 2.480 | 2.500 | 2.520 | V |
| | | LT1004M: $-55^\circ\text{C} \leq T_A \leq 125^\circ\text{C}$ | ● 1.220 | 1.230 | 1.245 | 2.460 | 2.500 | 2.535 | V |
| | | LT1004C: $0^\circ\text{C} \leq T_A \leq 70^\circ\text{C}$ | ● 1.225 | 1.235 | 1.245 | 2.470 | 2.500 | 2.530 | V |
| | | LT1004I: $-40^\circ\text{C} \leq T_A \leq 85^\circ\text{C}$ | ● 1.220 | 1.230 | 1.245 | 2.460 | 2.500 | 2.530 | V |
| $\frac{\Delta V_Z}{\Delta \text{Temp}}$ | Average Temperature Coefficient | $I_{\text{MIN}} \leq I_R \leq 20\text{mA}$ (Note 3) | | 20 | | 20 | | ppm/ $^\circ\text{C}$ | |
| I_{MIN} | Minimum Operating Current | | ● | 8 | 10 | 12 | 20 | μA | |
| $\frac{\Delta V_Z}{\Delta I_R}$ | Reverse Breakdown Voltage Change with Current | $I_{\text{MIN}} \leq I_R \leq 1\text{mA}$ | ● | | 1.0 | | 1.0 | mV | |
| | | $1\text{mA} \leq I_R \leq 20\text{mA}$ | ● | | 1.5 | | 1.5 | mV | |
| r_Z | Reverse Dynamic Impedance | $I_R = 100\mu\text{A}$ | ● | 0.2 | 0.6 | 0.2 | 0.6 | Ω | |
| | | | | | 1.5 | | 1.5 | Ω | |
| e_n | Wide Band Noise (RMS) | $I_R = 100\mu\text{A}$, $10\text{Hz} \leq f \leq 10\text{kHz}$ | | 60 | | 120 | | μV | |
| $\frac{\Delta V_Z}{\Delta \text{Time}}$ | Long Term Stability | $I_R = 100\mu\text{A}$, $T_A = 25^\circ\text{C} \pm 0.1^\circ\text{C}$ | | 20 | | 20 | | ppm/kHr | |

Note 1: Stresses beyond those listed under Absolute Maximum Ratings may cause permanent damage to the device. Exposure to any Absolute Maximum Rating condition for extended periods may affect device reliability and lifetime.

Note 2: All specifications are for $T_A = 25^\circ\text{C}$ unless otherwise noted.

Note 3: Selected devices with guaranteed maximum temperature coefficient are available upon request.

For MIL-STD components, please refer to LTC883C data sheet for test listing and parameters.

TYPICAL PERFORMANCE CHARACTERISTICS

Reverse Characteristics

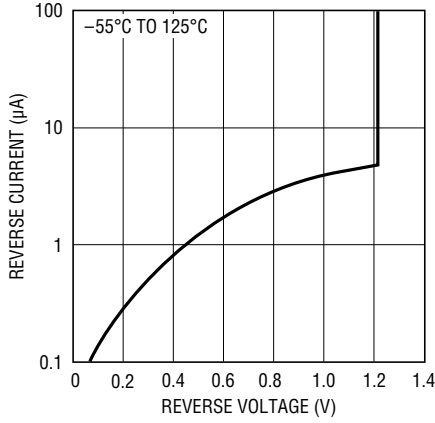

1004 G01

Reverse Voltage Change

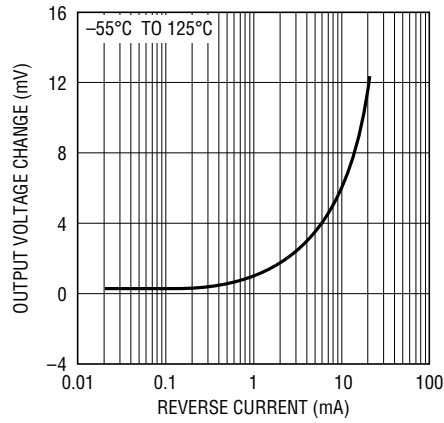

1004 G02

Forward Characteristics

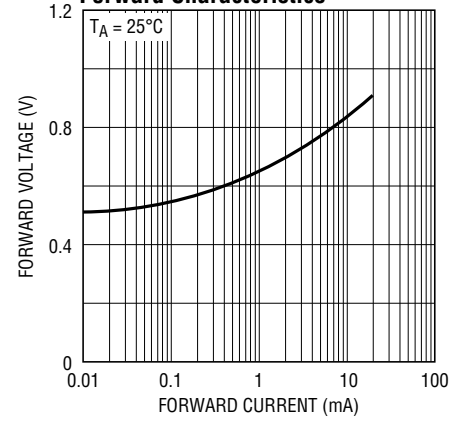

1004 G11

Temperature Drift

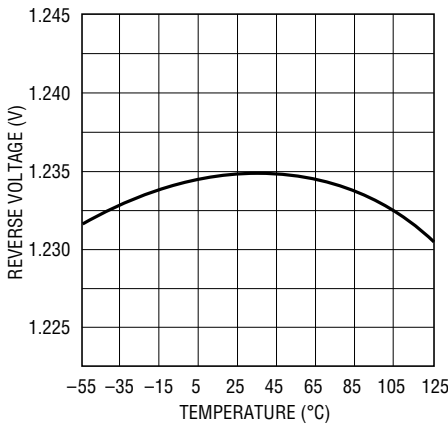

1004 G04

Reverse Dynamic Impedance

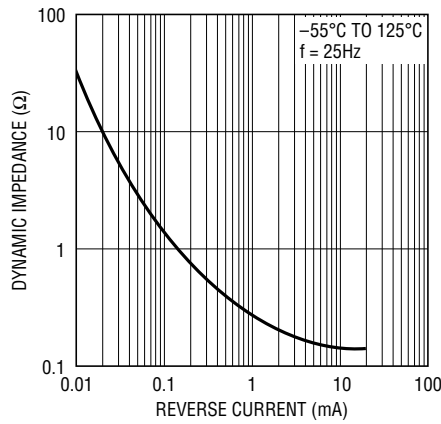

1004 G05

Reverse Dynamic Impedance

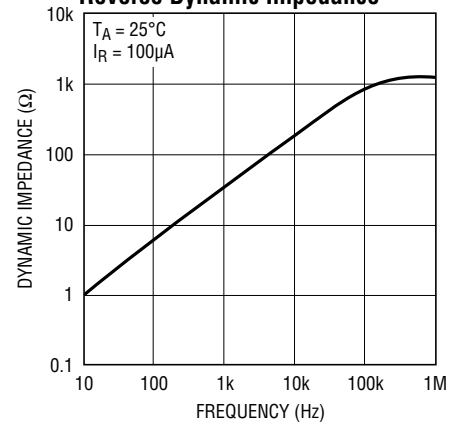

1004 G06

Noise Voltage

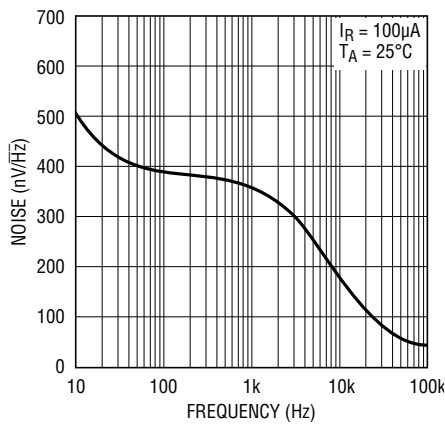

1004 G07

Filtered Output Noise

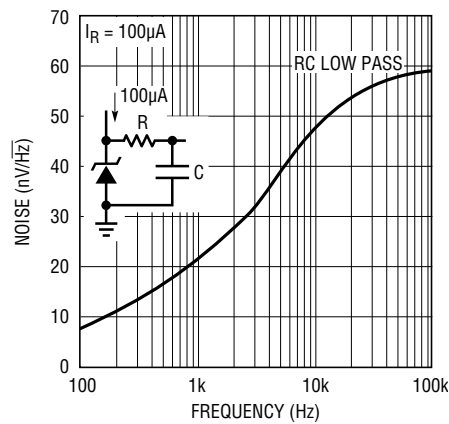

1004 G08

Reponse Time

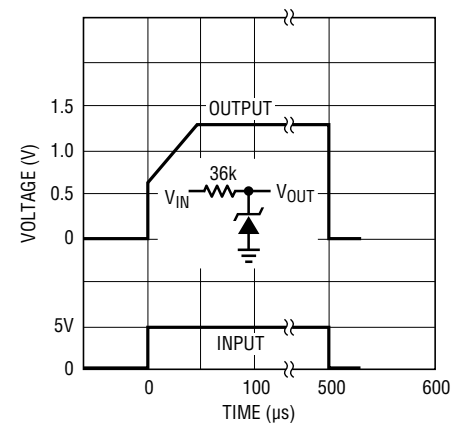

1004 G09

PERFORMANCE CHARACTERISTICS

Reverse Characteristics

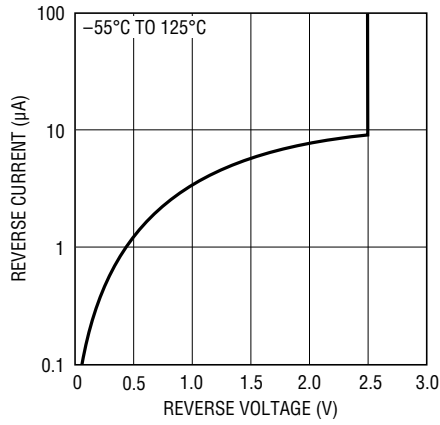

1004 G10

Forward Characteristics

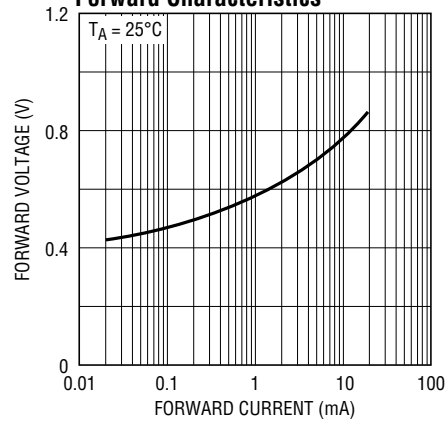

1004 G11

Temperature Drift

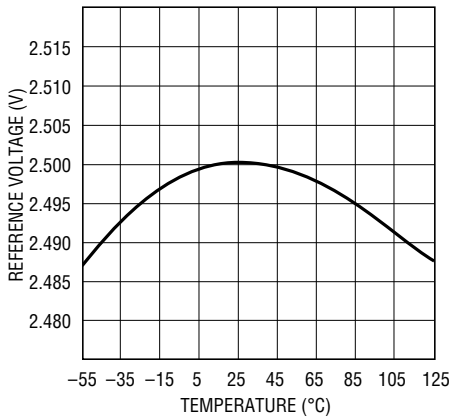

1004 G12

Reverse Dynamic Impedance

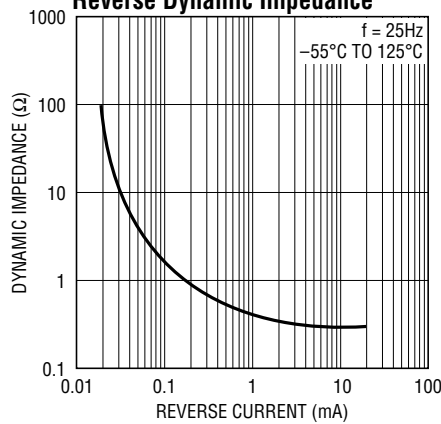

1004 G13

Reverse Dynamic Impedance

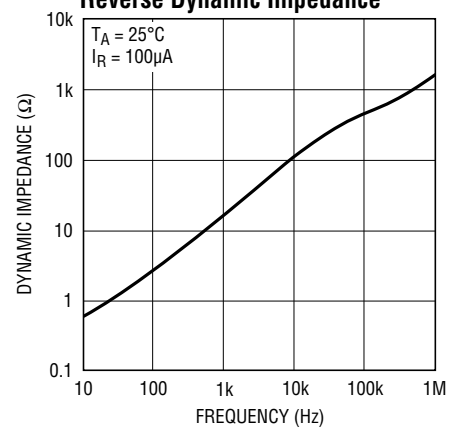

1004 G14

Noise Voltage

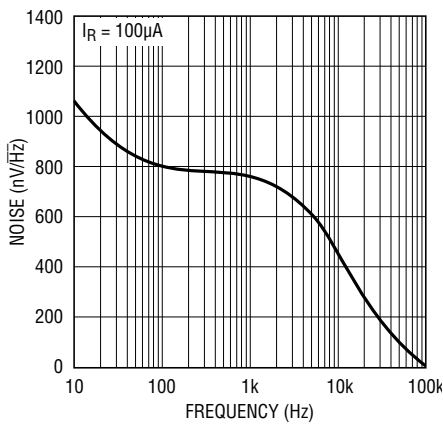

1004 G15

Filtered Output Noise

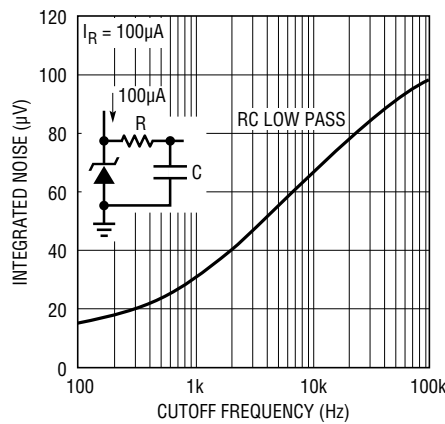

1004 G16

Reponse Time

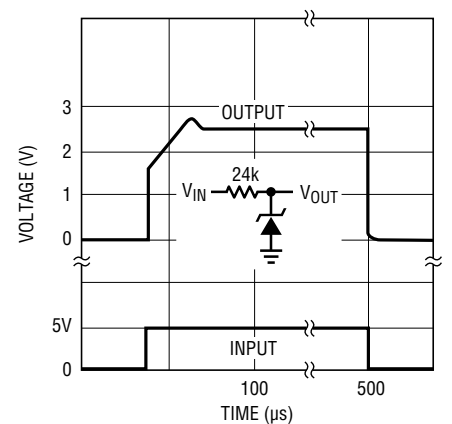

1004 G17

TYPICAL APPLICATIONS

High Stability 5V Regulator

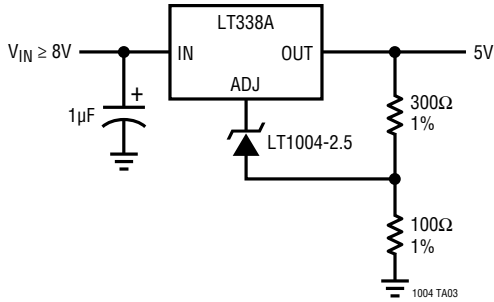

Variable Output Supply

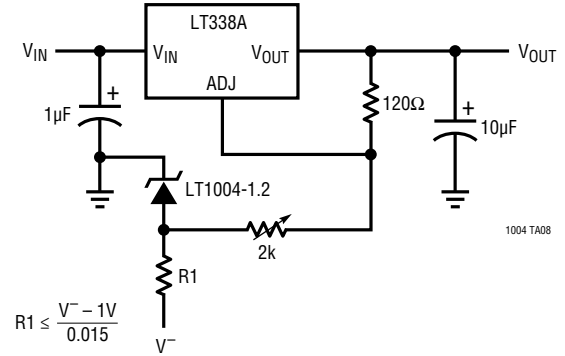

Constant Gain Amplifier Over Temperature

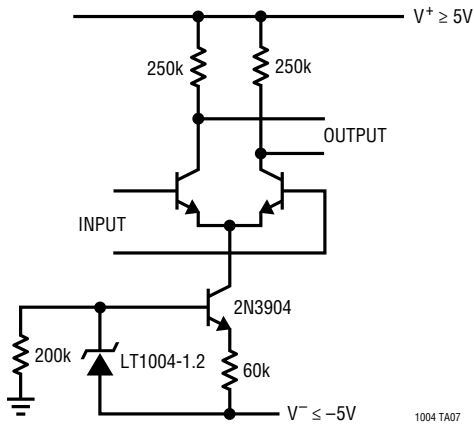

Micropower 5V Reference

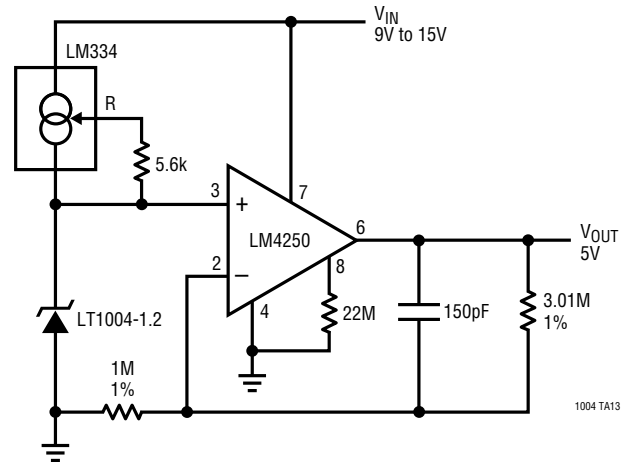

Lead Acid Low-Battery Detector

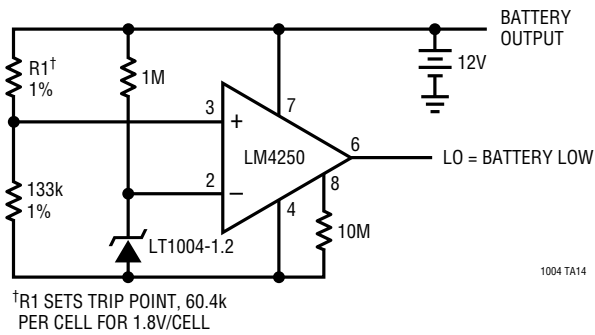

Ground Referenced Current Source

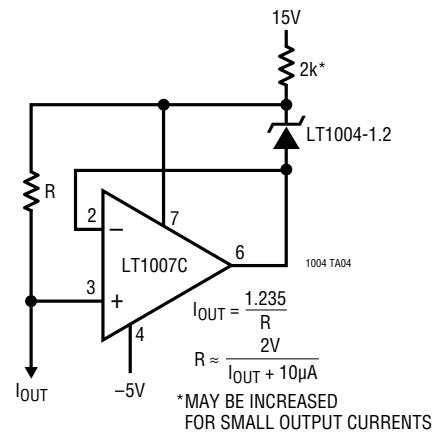

TYPICAL APPLICATIONS

VPP Generator for Eeproms — No Trim Required

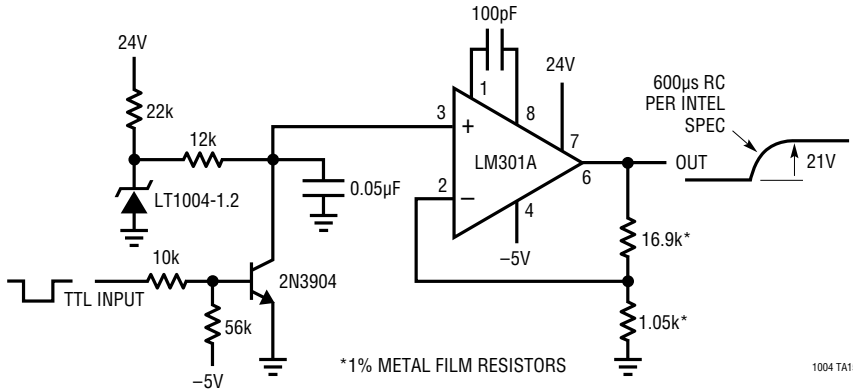

1.2V Reference from 1.5V Battery

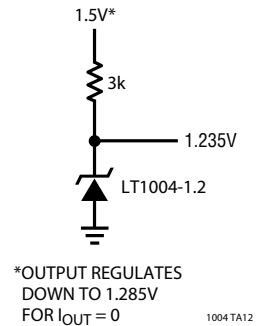

Micropower Reference from 9V Battery

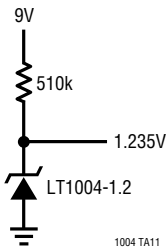

2.5V Reference

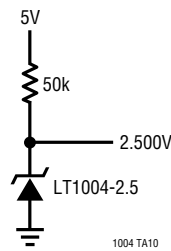

Low Noise Reference

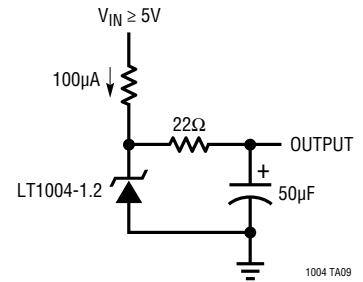

SCHEMATIC DIAGRAMS

LT1004-1.2

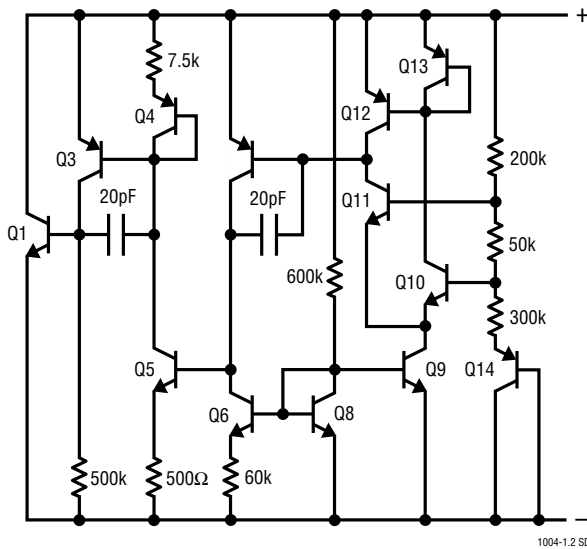

LT1004-2.5

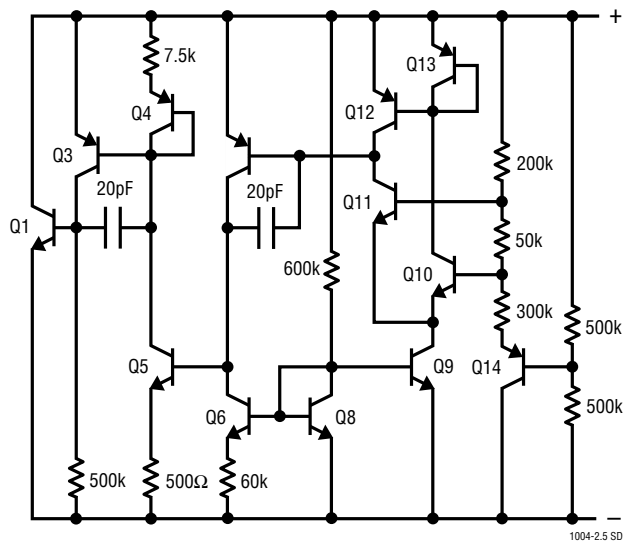

PACKAGE DESCRIPTION

Please refer to <http://www.linear.com/product/LT1004#packaging> for the most recent package drawings.

H Package
2-Lead and 3-Lead TO-46 Metal Can
 (Reference LTC DWG # 05-08-1340)

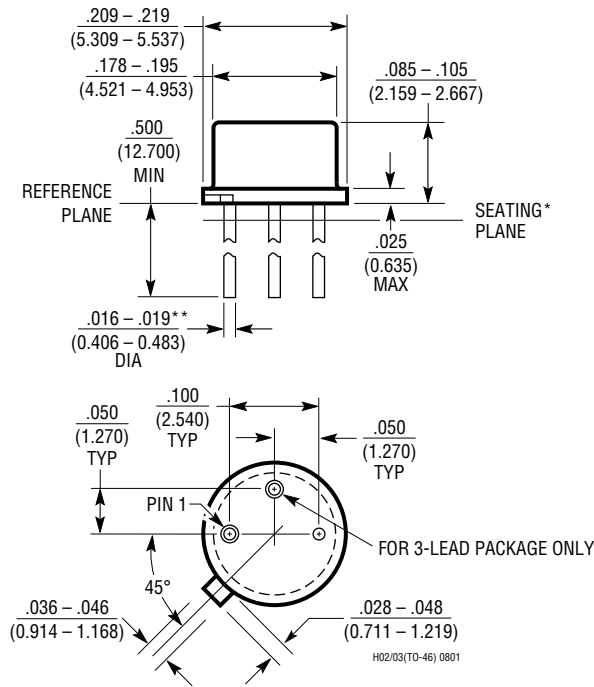

*LEAD DIAMETER IS UNCONTROLLED BETWEEN THE REFERENCE PLANE AND .050" BELOW THE REFERENCE PLANE

**FOR SOLDER DIP LEAD FINISH, LEAD DIAMETER IS $\frac{.016 - .024}{(0.406 - 0.610)}$

PACKAGE DESCRIPTION

Please refer to <http://www.linear.com/product/LT1004#packaging> for the most recent package drawings.

S8 Package 8-Lead Plastic Small Outline (Narrow .150 Inch) (Reference LTC DWG # 05-08-1610 Rev G)

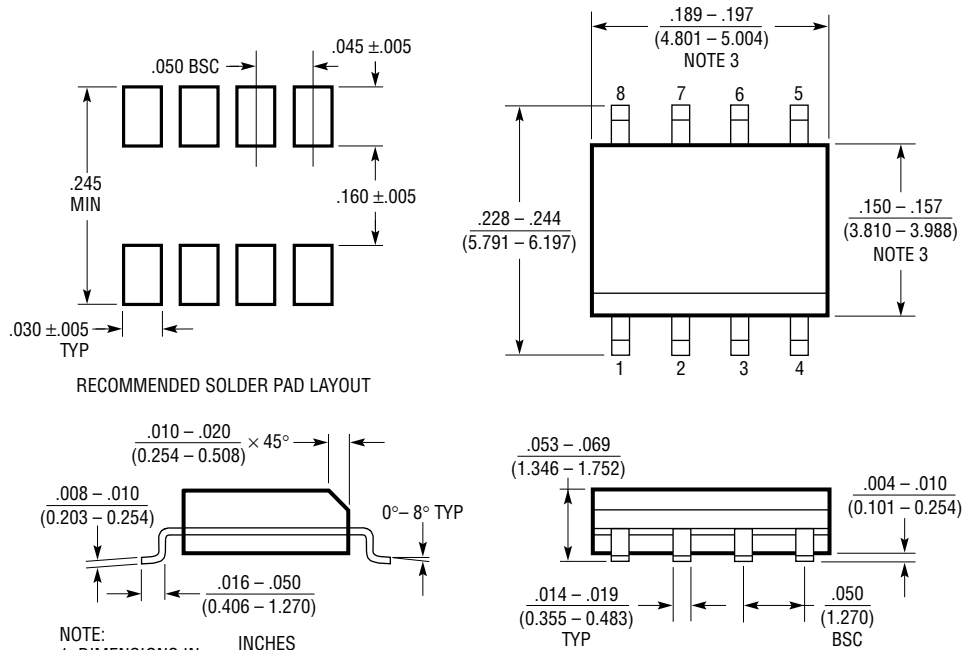

RECOMMENDED SOLDER PAD LAYOUT

- NOTE:
1. DIMENSIONS IN $\frac{\text{INCHES}}{\text{MILLIMETERS}}$
 2. DRAWING NOT TO SCALE
 3. THESE DIMENSIONS DO NOT INCLUDE MOLD FLASH OR PROTRUSIONS. MOLD FLASH OR PROTRUSIONS SHALL NOT EXCEED $.006"$ (0.15mm)
 4. PIN 1 CAN BE BEVEL EDGE OR A DIMPLE

S08 REV G 0212

PACKAGE DESCRIPTION

Please refer to <http://www.linear.com/product/LT1004#packaging> for the most recent package drawings.

Z Package
3-Lead Plastic TO-92 (Similar to TO-226)
 (Reference LTC DWG # 05-08-1410 Rev C)

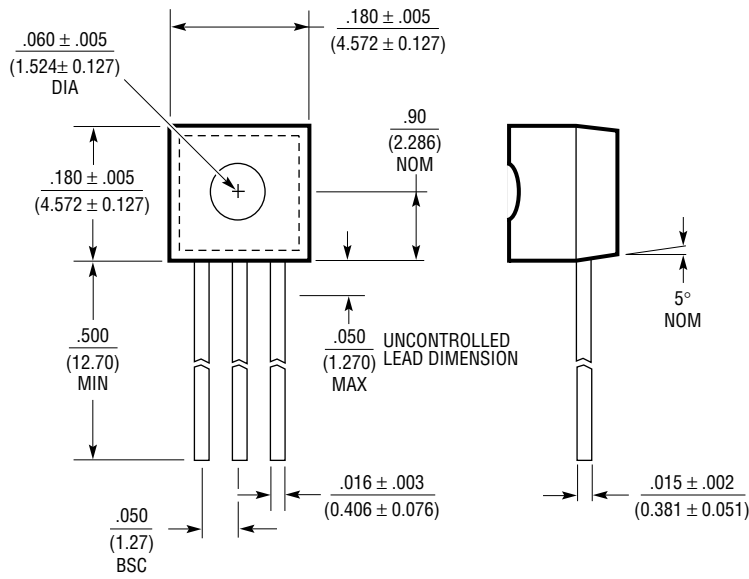

BULK PACK

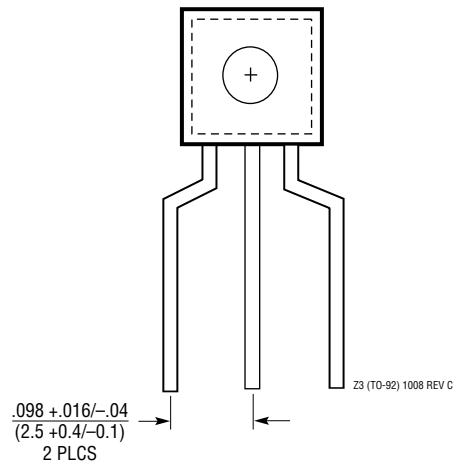

TO-92 TAPE AND REEL

REFER TO TAPE AND REEL SECTION OF LTC DATA BOOK FOR ADDITIONAL INFORMATION

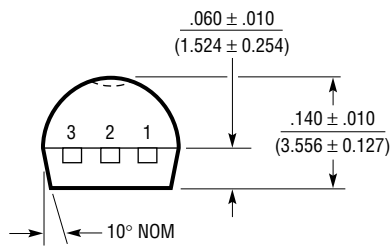

BULK PACK

REVISION HISTORY (Revision history begins at Rev C)

| REV | DATE | DESCRIPTION | PAGE NUMBER |
|-----|-------|---|-------------|
| C | 07/17 | Added Web Links Package Order Information Updated: T_{JMAX} changed to 150°C for S8 and TO-92 package. Thermal resistance (Junction to Ambient) changed to 120°C/W | All 2 |

TYPICAL APPLICATION

0°C to 100°C Linear Output Thermometer

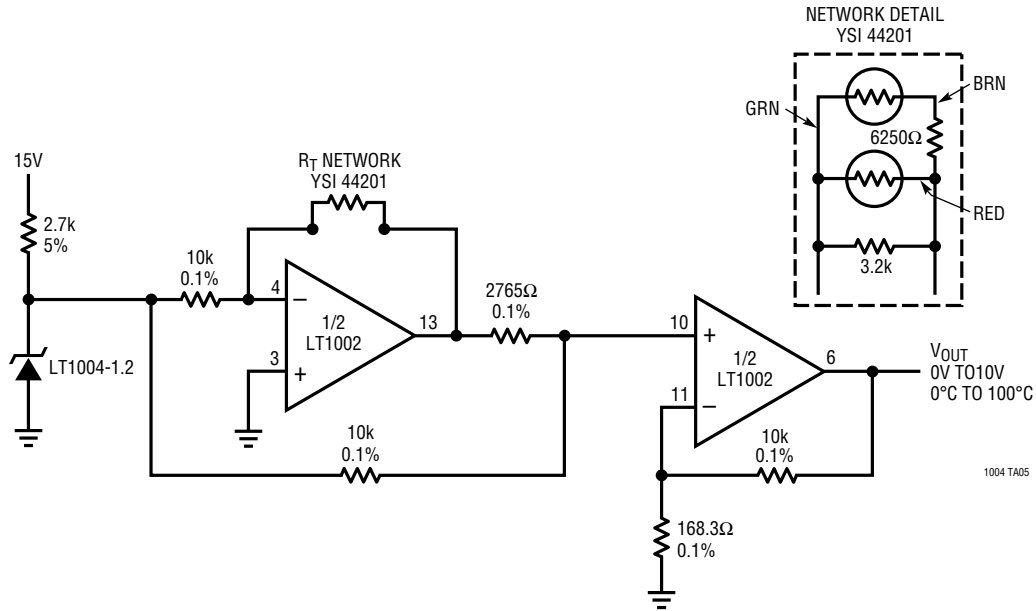

Low Temperature Coefficient 2-Terminal Current Source

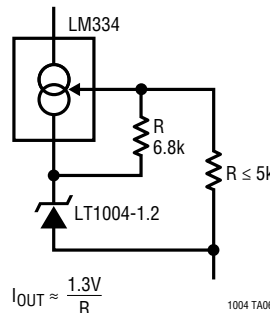

RELATED PARTS

| PART NUMBER | DESCRIPTION | COMMENTS |
|------------------------------|--|--|
| LT1634 | Micropower Precision Shunt Reference | 10µA Operating Current, 10ppm/°C Maximum Drift, 0.05% Initial Accuracy |
| LT1460S3-2.5 | Micropower Series Reference in SOT-23 | 100µA Operating Current, 20ppm/°C Maximum Drift, 0.2% Initial Accuracy |
| LT1790 | Precision Micropower LDO Reference in SOT-23 | 10ppm/°C Max Drift, 0.05% Initial Accuracy |

X-ON Electronics

Largest Supplier of Electrical and Electronic Components

Click to view similar products for [Voltage References](#) category:

Click to view products by [Analog Devices](#) manufacturer:

Other Similar products are found below :

[622664A](#) [636116E](#) [748389C](#) [AS431ARTR-E1](#) [NCP431BCSNT1G](#) [NCP432BCSNT1G](#) [NCV431BSNT1G](#) [AP4313UKTR-G1](#)
[TL1431AIYDT](#) [AZ431BR-ATRE1](#) [622668D](#) [NCP432BVSNT1G](#) [5962-8686103XC](#) [NCV431BVDMR2G](#) [AP4306BUKTR-G1](#)
[SC431BVSNT1G](#) [MAX6023EBT30+T](#) [NCV431ASNT1G](#) [LM4040CEM3-5.0/V+T](#) [LT1460KCS3-3#TRM](#) [LT1460KCS3-3.3#TRM](#)
[LT1019AIS8-2.5](#) [LT6660KCDC-10#TRMPBF](#) [LTC6652BHLS8-5#PBF](#) [LTC6652AHLS8-4.096#PBF](#) [LTC6655BHLS8-4.096#PBF](#)
[LT6660HCDC-5#TRMPBF](#) [LM336Z-2.5#PBF](#) [LT1021BMH-10](#) [SC431ILPRAG](#) [TLVH431MIL3T](#) [MAX6023EBT21+T](#) [AP432AQG-7](#)
[ADR4540CRZ](#) [LM4040B25QFTA](#) [TS3325AQPR](#) [REF102AU/2K5](#) [TL4050B25QDBZR](#) [TL4051C12QDCKR](#) [TL431ACZ](#) [KA431SLMF2TF](#)
[KA431SMF2TF](#) [KA431SMFTF](#) [LM385BXZ/NOPB](#) [LM4040QCEM3-3.0/NOPB](#) [LM4041C12ILPR](#) [LM4050AEM3X-5.0/NOPB](#)
[LM4050AIM3X-5.0/NOPB](#) [LM4120AIM5-2.5/NOP](#) [LM431SCCMFX](#)