

## SMT GaAs MMIC x2 ACTIVE FREQUENCY MULTIPLIER, 6 - 9 GHz OUTPUT



### Typical Applications

The HMC575LP4 / HMC575LP4E is suitable for:

- Wireless Local Loop
- Point-to-Point & VSAT Radios
- Test Instrumentation
- Military & Space

### Features

- High Output Power: +17 dBm
- Low Input Power Drive: -2 to +6 dBm
- Fo, 3Fo Isolation: 15 dBc
- 100 KHz SSB Phase Noise: -140 dBc/Hz
- Single Supply: +5V@ 90 mA
- RoHS Compliant 4x4 mm SMT Package

### Functional Diagram

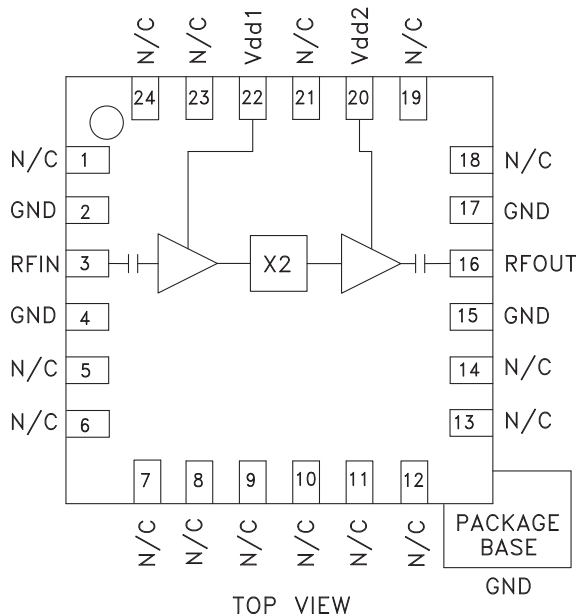

### General Description

The HMC575LP4 & HMC575LP4E are x2 active broadband frequency multipliers utilizing GaAs PHEMT technology in a leadless RoHS compliant SMT package. When driven by a 3 dBm signal, the multiplier provides +17 dBm typical output power from 6 to 9 GHz. The Fo and 3Fo isolations are 15 dBc with respect to output signal level. This frequency multiplier features DC blocked I/O's, and is ideal for use in LO multiplier chains for Pt to Pt & VSAT Radios yielding reduced parts count vs. traditional approaches. The low additive SSB Phase Noise of -140 dBc/Hz at 100 kHz offset helps maintain good system noise performance. The HMC575LP4 & HMC575LP4E are compatible with surface mount manufacturing techniques.

### Electrical Specifications, $T_A = +25^\circ C$ , $V_{dd1}, V_{dd2} = +5V$ , 3 dBm Drive Level

Parameter	Min.	Typ.	Max.	Units
Frequency Range, Input	3 - 4.5			GHz
Frequency Range, Output	6 - 9			GHz
Output Power	14	17		dBm
Fo Isolation (with respect to output level)		15		dBc
3Fo Isolation (with respect to output level)		15		dBc
Input Return Loss		15		dB
Output Return Loss		12		dB
SSB Phase Noise (100 kHz Offset)		-140		dBc/Hz
Supply Current (I <sub>dd1</sub> & I <sub>dd2</sub> )		90		mA

Information furnished by Analog Devices is believed to be accurate and reliable. However, no responsibility is assumed by Analog Devices for its use, nor for any infringements of patents or other rights of third parties that may result from its use. Specifications subject to change without notice. No license is granted by implication or otherwise under any patent or patent rights of Analog Devices. Trademarks and registered trademarks are the property of their respective owners.

For price, delivery, and to place orders: Analog Devices, Inc., One Technology Way, P.O. Box 9106, Norwood, MA 02062-9106 Phone: 781-329-4700 • Order online at [www.analog.com](http://www.analog.com) Application Support: Phone: 1-800-ANALOG-D

**SMT GaAs MMIC x2 ACTIVE FREQUENCY MULTIPLIER, 6 - 9 GHz OUTPUT**



**Output Power vs. Temperature @ 3 dBm Drive Level**

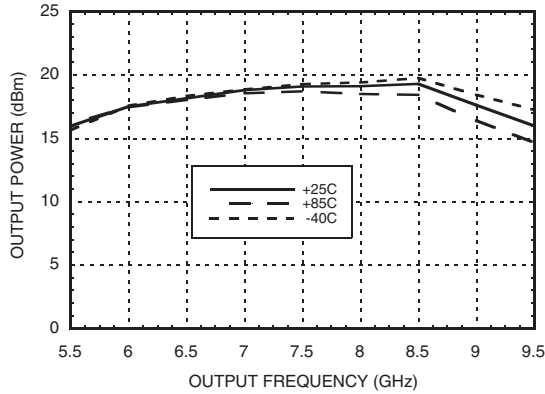

**Output Power vs. Drive Level**

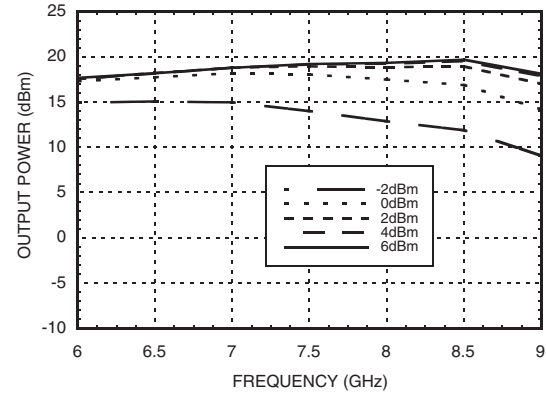

**Output Power vs. Supply Voltage @ 3 dBm Drive Level**

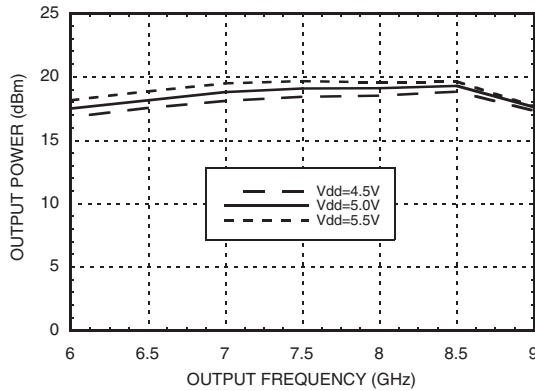

**Isolation @ 3 dBm Drive Level**

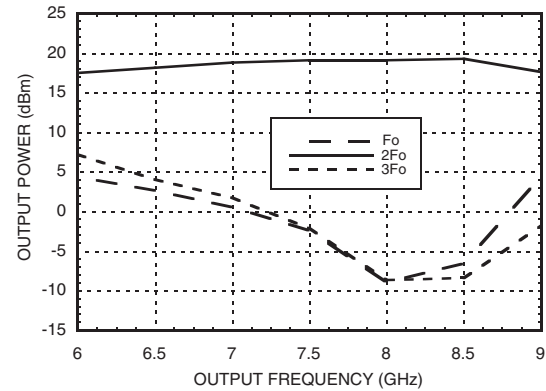

**Output Power vs. Input Power**

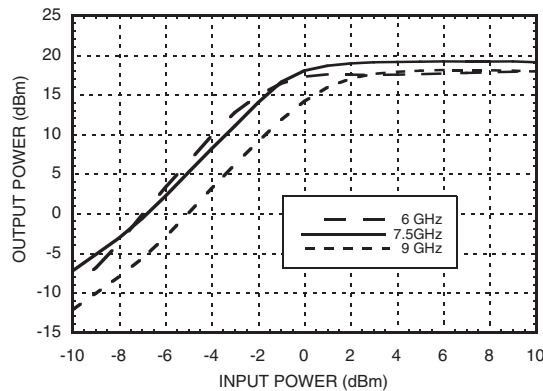

Information furnished by Analog Devices is believed to be accurate and reliable. However, no responsibility is assumed by Analog Devices for its use, nor for any infringements of patents or other rights of third parties that may result from its use. Specifications subject to change without notice. No license is granted by implication or otherwise under any patent or patent rights of Analog Devices. Trademarks and registered trademarks are the property of their respective owners.

For price, delivery, and to place orders: Analog Devices, Inc., One Technology Way, P.O. Box 9106, Norwood, MA 02062-9106 Phone: 781-329-4700 • Order online at [www.analog.com](http://www.analog.com) Application Support: Phone: 1-800-ANALOG-D

**SMT GaAs MMIC x2 ACTIVE FREQUENCY  
MULTIPLIER, 6 - 9 GHz OUTPUT**



**Input Return Loss vs. Temperature**

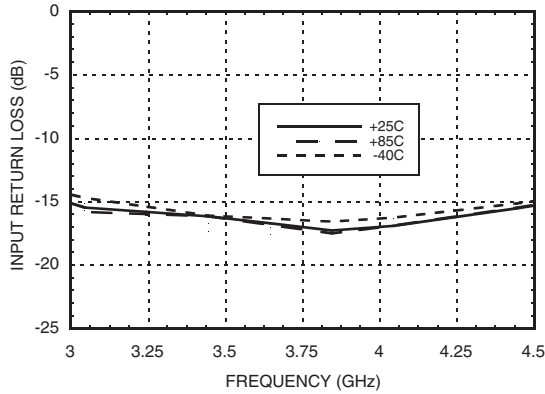

**Output Return Loss vs. Temperature**

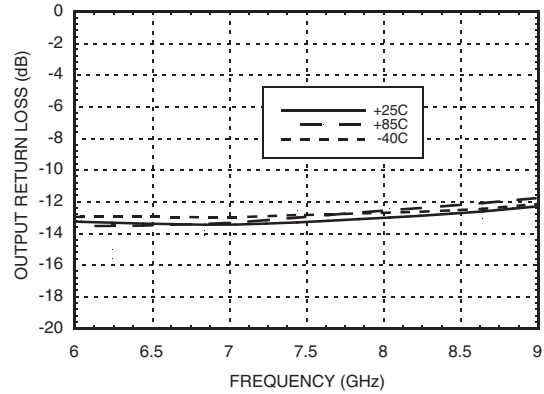

**Absolute Maximum Ratings**

RF Input (Vdd = +5V)	+13 dBm
Supply Voltage (Vdd)	+6.0 Vdc
Channel Temperature	150 °C
Continuous P <sub>diss</sub> (T= 85 °C) (derate 7.9 mW/°C above 85 °C)	512 mW
Thermal Resistance (channel to ground paddle)	127 °C/W
Storage Temperature	-65 to +150 °C
Operating Temperature	-40 to +85 °C

**Typical Supply Current vs. Vdd**

Vdd (Vdc)	I <sub>dd</sub> (mA)
4.5	89
5.0	90
5.5	91

Note:  
Multiplier will operate over full voltage range shown above.



**ELECTROSTATIC SENSITIVE DEVICE  
OBSERVE HANDLING PRECAUTIONS**

## SMT GaAs MMIC x2 ACTIVE FREQUENCY MULTIPLIER, 6 - 9 GHz OUTPUT



### Outline Drawing

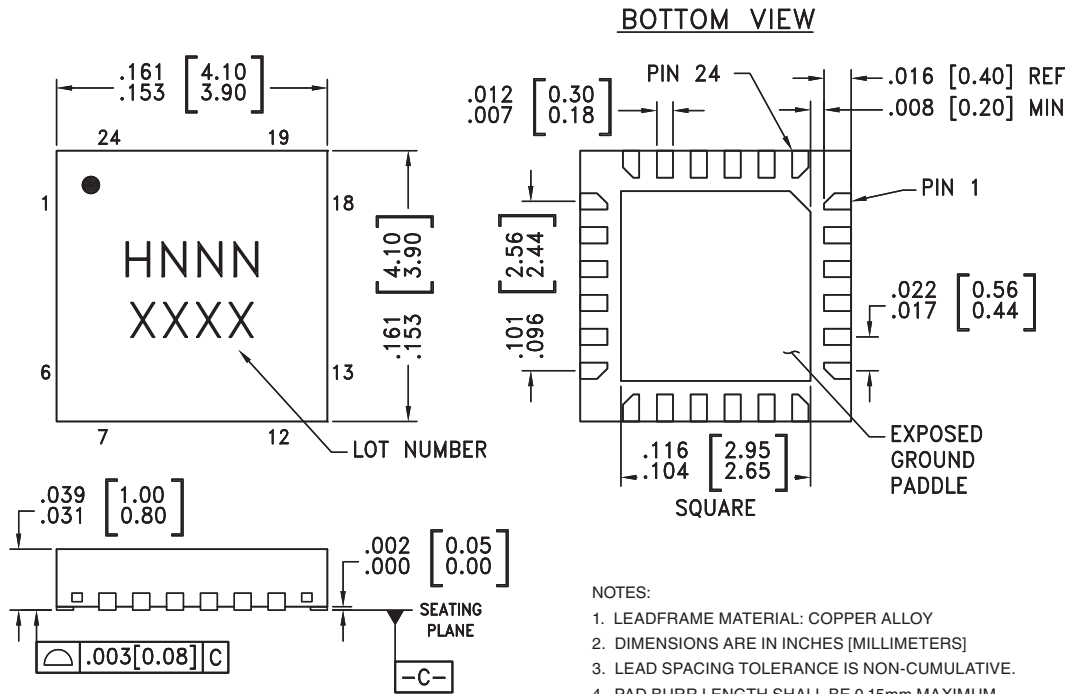

**NOTES:**

1. LEADFRAME MATERIAL: COPPER ALLOY
2. DIMENSIONS ARE IN INCHES [MILLIMETERS]
3. LEAD SPACING TOLERANCE IS NON-CUMULATIVE.
4. PAD BURR LENGTH SHALL BE 0.15mm MAXIMUM. PAD BURR HEIGHT SHALL BE 0.05mm MAXIMUM.
5. PACKAGE WARP SHALL NOT EXCEED 0.05mm.
6. ALL GROUND LEADS AND GROUND PADDLE MUST BE SOLDERED TO PCB RF GROUND.
7. REFER TO HITTITE APPLICATION NOT FOR SUGGESTED LAND PATTERN.

### Package Information

Part Number	Package Body Material	Lead Finish	MSL Rating	Package Marking <sup>[3]</sup>
HMC575LP4	Low Stress Injection Molded Plastic	Sn/Pb Solder	MSL1 <sup>[1]</sup>	H575 XXXX
HMC575LP4E	RoHS-compliant Low Stress Injection Molded Plastic	100% matte Sn	MSL1 <sup>[2]</sup>	H575 XXXX

[1] Max peak reflow temperature of 235 °C

[2] Max peak reflow temperature of 260 °C

[3] 4-Digit lot number XXXX

**SMT GaAs MMIC x2 ACTIVE FREQUENCY MULTIPLIER, 6 - 9 GHz OUTPUT**



**Pin Description**

Pin Number	Function	Description	Interface Schematic
1, 5 - 14, 18, 19, 21, 23, 24	N/C	These pins are internally not connected; however, this product was specified with these pins connected to RF/ DC ground.	
2, 4, 15, 17	GND	Package bottom must also be connected to RF/DC ground.	
3	RFIN	Pin is AC coupled and matched to 50 Ohms from 3 - 4.5 GHz.	
16	RFOUT	Pin is AC coupled and matched to 50 Ohms from 6 - 9 GHz.	
20, 22	Vdd2, Vdd1	Supply voltage 5V ± 0.5V. External bypass capacitors of 100 pF and 2.2 μF are required.	

**Application Circuit**

Component	Value
C1, C2	100 pF
C3, C4	2.2 μF

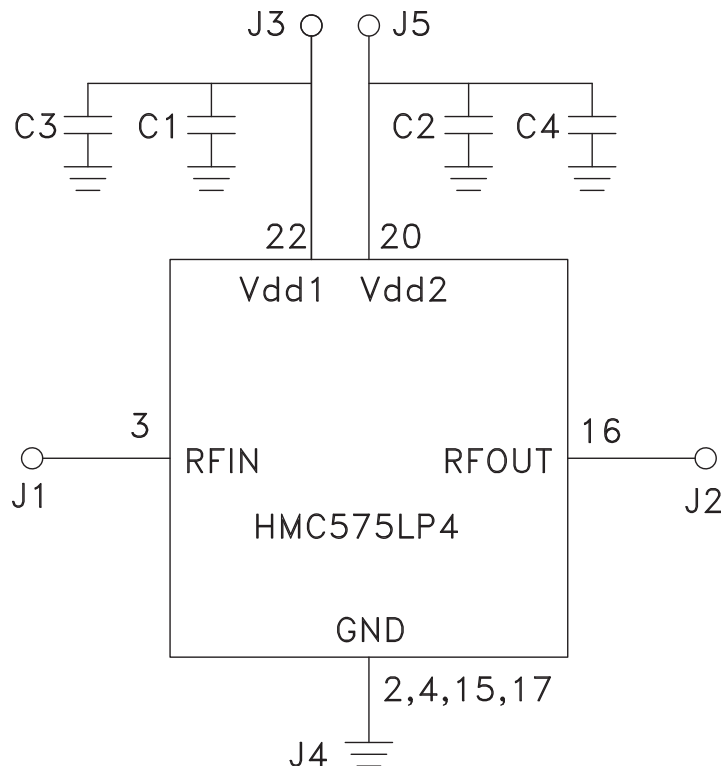

Information furnished by Analog Devices is believed to be accurate and reliable. However, no responsibility is assumed by Analog Devices for its use, nor for any infringements of patents or other rights of third parties that may result from its use. Specifications subject to change without notice. No license is granted by implication or otherwise under any patent or patent rights of Analog Devices. Trademarks and registered trademarks are the property of their respective owners.

For price, delivery, and to place orders: Analog Devices, Inc., One Technology Way, P.O. Box 9106, Norwood, MA 02062-9106 Phone: 781-329-4700 • Order online at [www.analog.com](http://www.analog.com) Application Support: Phone: 1-800-ANALOG-D



### Evaluation PCB

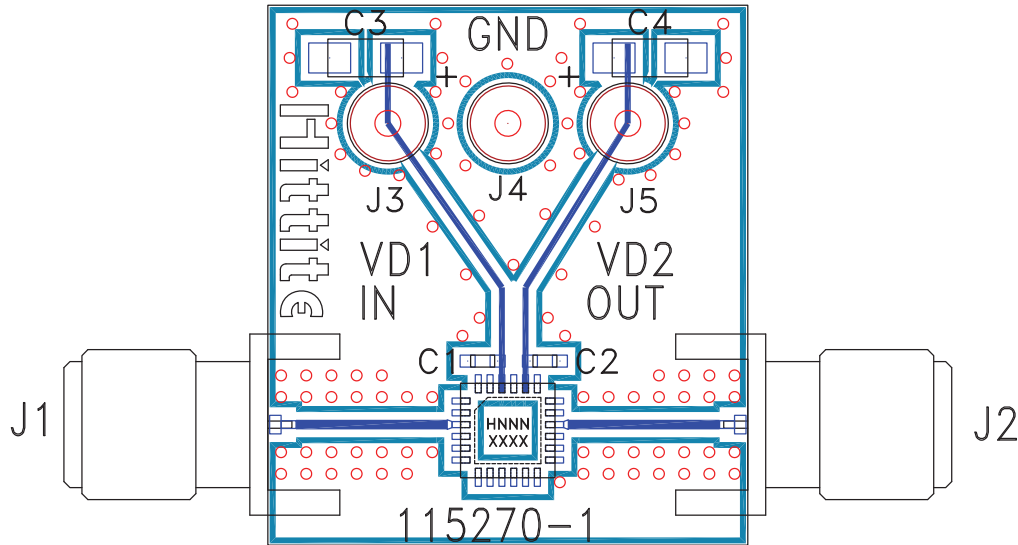

### List of Materials for Evaluation PCB 112405 [1]

Item	Description
J1, J2	PCB Mount SRI SMA Connector
J3 - J5	DC Pin
C1, C2	100 pF Capacitor, 0402 Pkg.
C3, C4	2.2 μF Tantalum Capacitor
U1	HMC575LP4 / HMC575LP4E x2 Active Multiplier
PCB [2]	115270 Eval Board

[1] Reference this number when ordering complete evaluation PCB

[2] Circuit Board Material: Rogers 4350

The circuit board used in the final application should be generated with proper RF circuit design techniques. Signal lines should have 50 ohm impedance while the package ground leads and exposed paddle should be connected directly to the ground plane similar to that shown. The evaluation circuit board shown is available from Hittite upon request.

## X-ON Electronics

Largest Supplier of Electrical and Electronic Components

*Click to view similar products for [RF Development Tools](#) category:*

*Click to view products by [Analog Devices](#) manufacturer:*

Other Similar products are found below :

[MAAM-011117](#) [MAAP-015036-DIEEV2](#) [EV1HMC1113LP5](#) [EV1HMC6146BLC5A](#) [EV1HMC637ALP5](#) [EVAL-ADG919EBZ](#) [ADL5363-EVALZ](#) [LMV228SDEVAL](#) [SKYA21001-EVB](#) [SMP1331-085-EVB](#) [EV1HMC618ALP3](#) [EVAL01-HMC1041LC4](#) [MAAL-011111-000SMB](#) [MAAM-009633-001SMB](#) [MASW-000936-001SMB](#) [107712-HMC369LP3](#) [107780-HMC322ALP4](#) [SP000416870](#) [EV1HMC470ALP3](#) [EV1HMC520ALC4](#) [EV1HMC244AG16](#) [MAX2614EVKIT#](#) [124694-HMC742ALP5](#) [SC20ASATEA-8GB-STD](#) [MAX2837EVKIT+](#) [MAX2612EVKIT#](#) [MAX2692EVKIT#](#) [EV1HMC629ALP4E](#) [SKY12343-364LF-EVB](#) [108703-HMC452QS16G](#) [EV1HMC863ALC4](#) [119197-HMC658LP2](#) [EV1HMC647ALP6](#) [ADL5725-EVALZ](#) [106815-HMC441LM1](#) [EV1HMC1018ALP4](#) [UXN14M9PE](#) [MAX2016EVKIT](#) [EV1HMC939ALP4](#) [MAX2410EVKIT](#) [MAX2204EVKIT+](#) [EV1HMC8073LP3D](#) [SIMSA868-DKL](#) [SIMSA868C-DKL](#) [SKY65806-636EK1](#) [SKY68020-11EK1](#) [SKY67159-396EK1](#) [SKY66181-11-EK1](#) [SKY65804-696EK1](#) [SKY13396-397LF-EVB](#)