

## QUAD LOW NOISE HIGH PSRR LINEAR VOLTAGE REGULATOR



### Typical Applications

The HMC860LP3E is ideal for:

- Test Instrumentation
- Military Radios, Radar and ECM
- Basestation Infrastructure
- Ultra Low Noise Frequency Generation
- Fractional-N Synthesizer Supply
- Mixed-Signal Circuit Supply

### Features

- Ultra Low Noise:  
3nV/√Hz at 10 kHz, 7nV/√Hz at 1 kHz
- High Power Supply Rejection Ratio (PSRR)  
80 dB at 1 kHz, 60 dB at 1 MHz
- Four Voltage Outputs:  
VR1 @ 3V / 80 mA  
VR2, VR3 @ 3V / 20 mA  
VR4 @ 4.5V / 120 mA
- Adjustable Outputs: 2.5V to 5.2V
- Low Power-Down Current: <1 μA
- 16 Lead 3x3 mm SMT Package: 9mm<sup>2</sup>

### Functional Diagram

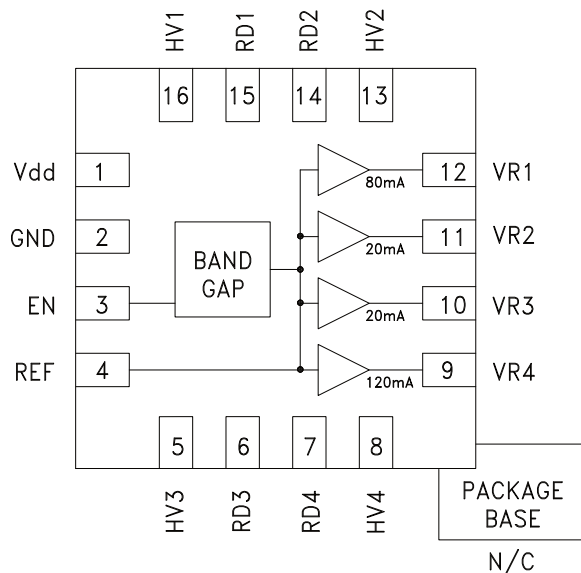

### General Description

The HMC860LP3E is a BiCMOS ultra low noise quad-output voltage regulator. It features a low noise band-gap reference externally decoupled for best in-close noise performance. High Power Supply Rejection Ratio (PSRR) in the 0.1 MHz to 10 MHz range provides excellent rejection of preceding switching regulator noise. The four voltage outputs are ideal for frequency generation subsystems including Hittite's broad line of PLLs with Integrated VCOs.

Each output voltage can be adjusted higher or lower than the default value by using one external resistor. Each output can be set to 5V by grounding the corresponding HV pin. The regulator can be powered down by the TTL-compatible Enable input. The HMC860LP3E is housed in a 3x3mm QFN SMT package.

### Electrical Specifications, $T_A = +25^\circ\text{C}$

Parameter	Conditions	Min	Typ	Max	Units
Default Output Voltage VR1, VR2, VR3	Vdd = 5.5V; Maximum load current	3	3.05	3.1	V
Default Output Voltage VR4	Vdd = 5.5V; Maximum load current	4.4	4.5	4.6	V
Output Voltage Tolerance	Vdd = 5.5V; Maximum load current			2	%
Input Voltage Range (Default)	Default output voltage configuration	4.8		5.6	V
Input Voltage Range	E.g.: VR1 = VR2 = VR3 = VR4 = 3.05V; Vdd, min = 3.35V	Max (VRx) + 0.3V		5.6	V
Output Voltage Range VR1 to VR4	Set by external resistors. Vdd = Max(VRx)+0.3V	2.5		5.2	V

Information furnished by Analog Devices is believed to be accurate and reliable. However, no responsibility is assumed by Analog Devices for its use, nor for any infringements of patents or other rights of third parties that may result from its use. Specifications subject to change without notice. No license is granted by implication or otherwise under any patent or patent rights of Analog Devices. Trademarks and registered trademarks are the property of their respective owners.

For price, delivery, and to place orders: Analog Devices, Inc., One Technology Way, P.O. Box 9106, Norwood, MA 02062-9106  
Phone: 781-329-4700 • Order online at [www.analog.com](http://www.analog.com)  
Application Support: Phone: 1-800-ANALOG-D



## QUAD LOW NOISE HIGH PSRR LINEAR VOLTAGE REGULATOR

### Electrical Specifications (Continued)

Parameter	Conditions	Min	Typ	Max	Units
Reference Voltage VREF	Vdd = 5.5V; REF cannot source/sink external current		1.21		V
Output Current VR1 [1]	T <sub>A</sub> = -40°C to +85°C			80	mA
Output Current VR2, VR3 [1]	T <sub>A</sub> = -40°C to +85°C			20	mA
Output Current VR4 [1]	T <sub>A</sub> = -40°C to +85°C			120	mA
Total Output Current	T <sub>A</sub> = -40°C to +85°C			240	mA
Output Noise Spectral Density 10 Hz 100 Hz 1 kHz 10 kHz 100 kHz	Vdd = 5.5V; VRx = 3.05V; VR4 = 4.5V Measured on Application Schematic Maximum Load Current		2200 157 7 3 3		nV/√Hz
Integrated Output Noise 100 Hz to 100 kHz	Vdd = 5.5V; VRx = 3.05V		1.5		μVrms
Load Regulation, VR1	Vdd = 5.5V		0.01		% / mA
Load Regulation, VR2 & VR3	Vdd = 5.5V		0.02		% / mA
Load Regulation, VR4	Vdd = 5.5V		0.02		% / mA
PSRR 0 Hz (DC Line Regulation) 1 kHz 100 kHz 1 MHz 10 MHz 50 MHz	Vdd = 5.5V; Maximum load current		36 80 65 60 35 45		dB
Output Voltage Variation vs. Package Base Temperature 25°C to 85°C -40°C to 25°C	Vdd = 5.5V; Maximum load current		0.015 0.045		% / °C % / °C
Current Consumption (I <sub>GND</sub> )	Ven = Vdd = 5.5V; Maximum Load Current		1.9	2.3	mA
Power Down Current	Vdd = 5.5V; EN = Low; VRx outputs are floating (high - impedance) in Power-Down mode			1	μA
Start-Up Transient Time	0 to 90% of final voltage; Cref=1 μF; Cload=10 μF; Vdd = 5.5V		25		ms
EN Turn-On Delay	0 to 90% of final output voltage Cref = 1 μF; Cload = 10 μF; Vdd = 5.5V EN transition from 0 to Vdd		25		ms
Enable Input EN High Level		2		Vdd + 0.3	V
Enable Input EN Low Level		0		0.8	V
Output Load Capacitance	To guarantee stability, noise and PSRR performance	10			μF
Output Capacitor ESR	Required if no series resistor is used at the output. See "Stability" section.	0.2		2	Ohm
Output series resistance	Required if ESR is insufficient for one or more output capacitors. See "Stability" section.	0.1		1	Ohm

[1] The regulator does not include short-circuit or over-temperature protection circuitry. The outputs will withstand short-circuit conditions for a duration of less than 10s.



**QUAD LOW NOISE HIGH PSRR  
LINEAR VOLTAGE REGULATOR**

**VR1 Noise Spectral Density, Vdd = 5.5V**

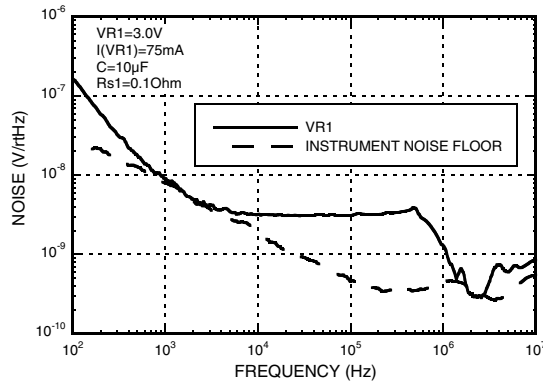

**VR2, VR3 Noise Spectral Density,  
Vdd = 5.5V**

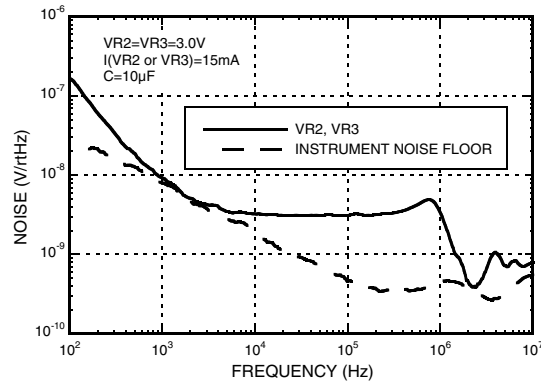

**VR4 Noise Spectral Density, Vdd = 5.5V**

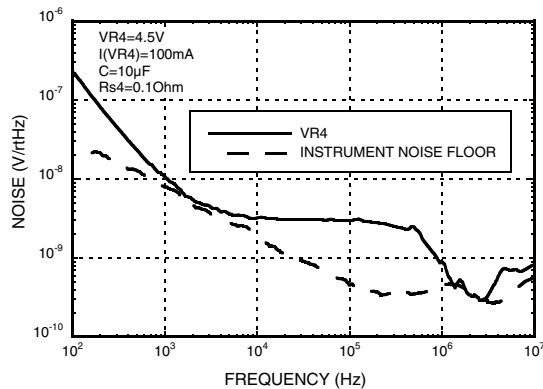

**VR1, VR4 Power Supply Rejection  
Ratio (PSRR), Vdd = 5.5V**

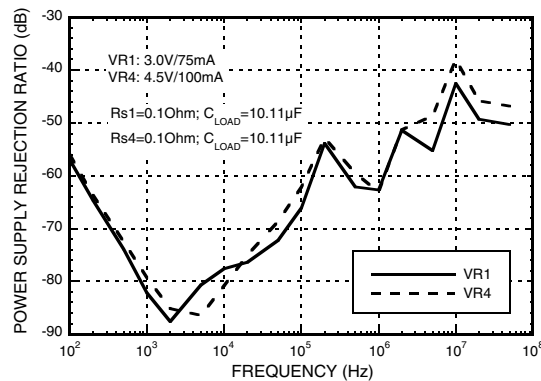

**VR2, VR3 Power Supply Rejection  
Ratio (PSRR), Vdd = 5.5V**

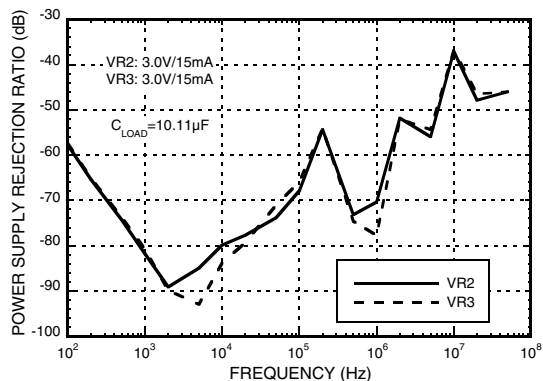

**VR1 Voltage vs. Supply, I(VR1) = 75 mA**

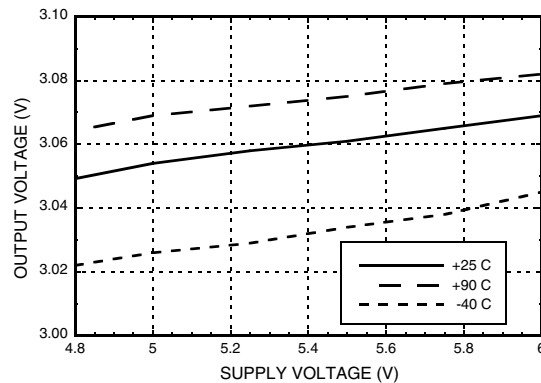



**QUAD LOW NOISE HIGH PSRR  
LINEAR VOLTAGE REGULATOR**

**VR1 Voltage vs. Supply,  $T = 25\text{ }^{\circ}\text{C}$**

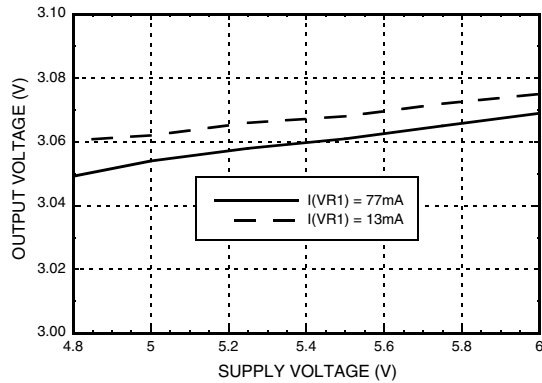

**VR4 Voltage vs. Supply,  $I(\text{VR4}) = 100\text{ mA}$**

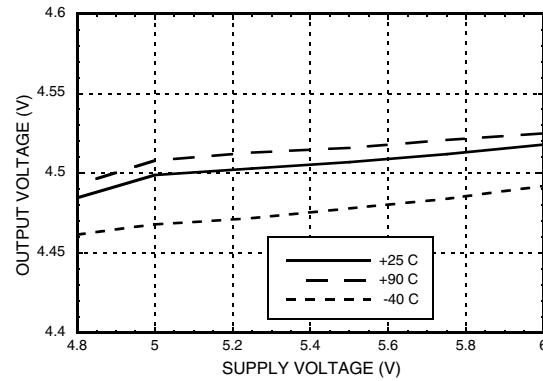

**VR1 Voltage vs. Temperature,  
 $I(\text{VR1}) = 75\text{ mA}$**

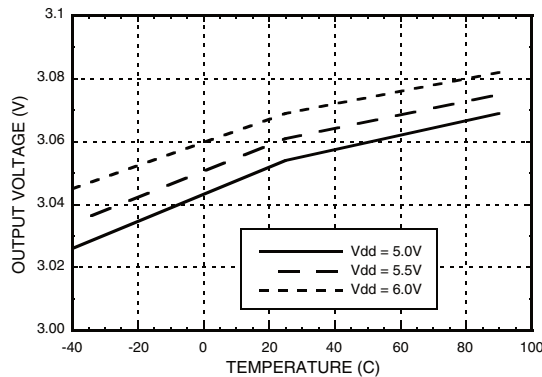

**VR4 Voltage vs. Temperature,  
 $I(\text{VR4}) = 100\text{ mA}$**

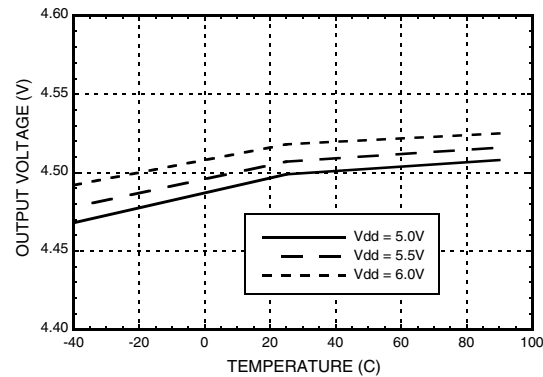

**Supply Turn-On Transient,  $T = 90\text{ }^{\circ}\text{C}$**

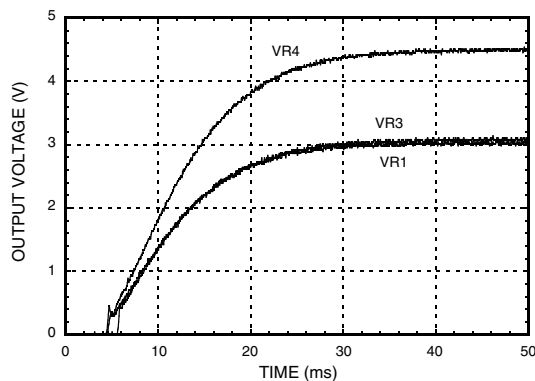

**Supply Turn-Off Transient,  $T = 90\text{ }^{\circ}\text{C}$**

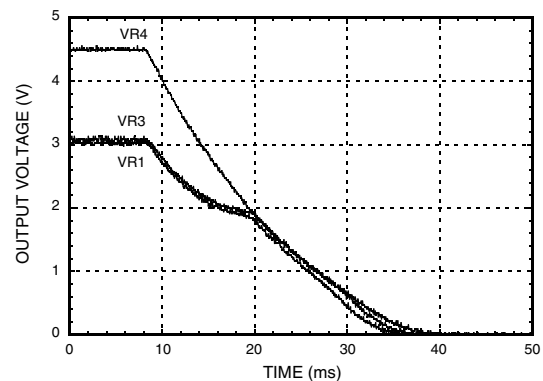

Information furnished by Analog Devices is believed to be accurate and reliable. However, no responsibility is assumed by Analog Devices for its use, nor for any infringements of patents or other rights of third parties that may result from its use. Specifications subject to change without notice. No license is granted by implication or otherwise under any patent or patent rights of Analog Devices. Trademarks and registered trademarks are the property of their respective owners.

For price, delivery, and to place orders: Analog Devices, Inc., One Technology Way, P.O. Box 9106, Norwood, MA 02062-9106 Phone: 781-329-4700 • Order online at [www.analog.com](http://www.analog.com) Application Support: Phone: 1-800-ANALOG-D



## QUAD LOW NOISE HIGH PSRR LINEAR VOLTAGE REGULATOR

### Absolute Maximum Ratings

Vdd to GND Voltage	+6.5V / -0.3V
EN to GND Voltage	Vdd + 0.5V / -0.3V
RDx / HVx to GND Voltage	Vdd + 0.5V / -0.3V
Thermal Resistance (Junction to ground paddle)	30 °C/W
Maximum Junction Temperature	+125 °C
Storage Temperature	-65 to +150 °C
Operating Temperature	-40 to +85 °C
ESD Sensitivity (HBM)	Class 1C

Stresses above those listed under Absolute Maximum Ratings may cause permanent damage to the device. This is a stress rating only; functional operation of the device at these or any other conditions above those indicated in the operational section of this specification is not implied. Exposure to absolute maximum rating conditions for extended periods may affect device reliability. The absolute maximum ratings apply individually only and not in combination.



**ELECTROSTATIC SENSITIVE DEVICE  
OBSERVE HANDLING PRECAUTIONS**

### Outline Drawing

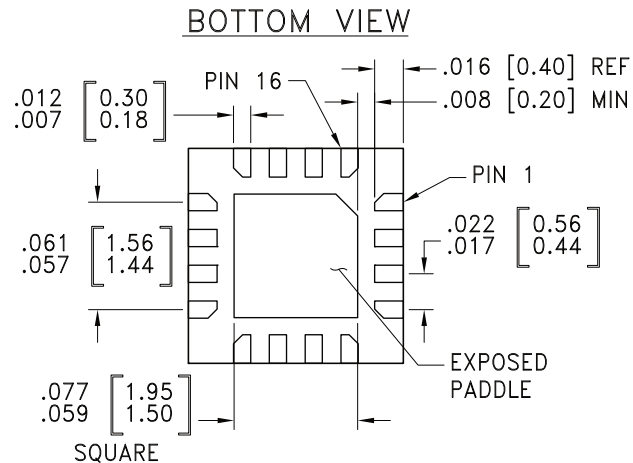
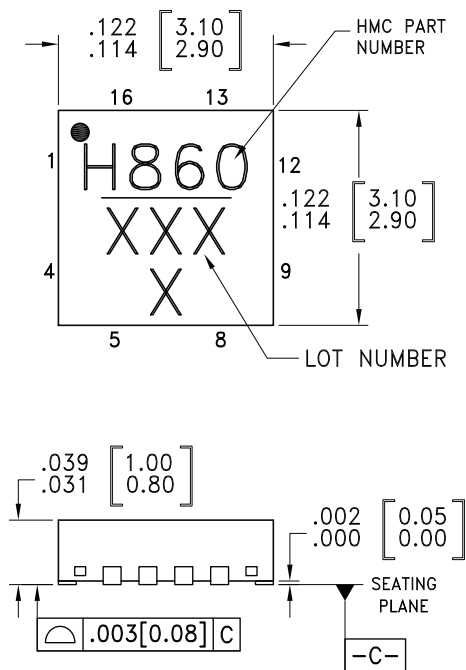

**NOTES:**

1. LEADFRAME MATERIAL: COPPER ALLOY
2. DIMENSIONS ARE IN INCHES [MILLIMETERS].
3. DIMENSION DOES NOT INCLUDE MOLDFLASH OF 0.15mm PER SIDE.
4. DIMENSION DOES NOT INCLUDE MOLDFLASH OF 0.25mm PER SIDE.
5. ALL GROUND LEADS MUST BE SOLDERED TO PCB GROUND.
6. CLASSIFIED AS MOISTURE SENSITIVITY LEVEL (MSL) 1.

### Package Information

Part Number	Package Body Material	Lead Finish	MSL Rating	Package Marking <sup>[1]</sup>
HMC860LP3E	RoHS-compliant Low Stress Injection Molded Plastic	100% matte Sn	MSL1 <sup>[2]</sup>	H860 XXX X

[1] 4-Digit lot number XXXX

[2] Max peak reflow temperature of 260 °C



## QUAD LOW NOISE HIGH PSRR LINEAR VOLTAGE REGULATOR

### Pin Descriptions

Pin Number	Function	Description	Interface Schematic
1	Vdd	Unregulated power supply input	
2	GND	Supply Ground	
3	EN	Enable Input, TTL Logic Level. The VRx outputs are floating (high impedance) when EN = Low.	
4	REF	Reference voltage (bandgap) output. Cannot be used to source/sink current to/from external circuits	
5	HV3	Sets VR3 to 5V output when connected to ground, otherwise no connection.	
8	HV4	Sets VR4 to 5V output when connected to ground, otherwise no connection.	
13	HV2	Sets VR2 to 5V output when connected to ground, otherwise no connection.	
16	HV1	Sets VR1 to 5V output when connected to ground, otherwise no connection.	
6	RD3	Resistive feedback for VR3, see "Output Voltage Adjust" section.	
7	RD4	Resistive feedback for VR4, see "Output Voltage Adjust" section.	
14	RD2	Resistive feedback for VR2, see "Output Voltage Adjust" section.	
15	RD1	Resistive feedback for VR1, see "Output Voltage Adjust" section.	
9	VR4	Regulator #4 Output	
10	VR3	Regulator #3 Output	
11	VR2	Regulator #2 Output	
12	VR1	Regulator #1 Output	
Package Base	N/C	Should contact PCB metallic area for best thermal dissipation. Can be connected to Ground.	

Information furnished by Analog Devices is believed to be accurate and reliable. However, no responsibility is assumed by Analog Devices for its use, nor for any infringements of patents or other rights of third parties that may result from its use. Specifications subject to change without notice. No license is granted by implication or otherwise under any patent or patent rights of Analog Devices. Trademarks and registered trademarks are the property of their respective owners.

For price, delivery, and to place orders: Analog Devices, Inc., One Technology Way, P.O. Box 9106, Norwood, MA 02062-9106  
Phone: 781-329-4700 • Order online at [www.analog.com](http://www.analog.com)  
Application Support: Phone: 1-800-ANALOG-D



## QUAD LOW NOISE HIGH PSRR LINEAR VOLTAGE REGULATOR

### Application Schematic

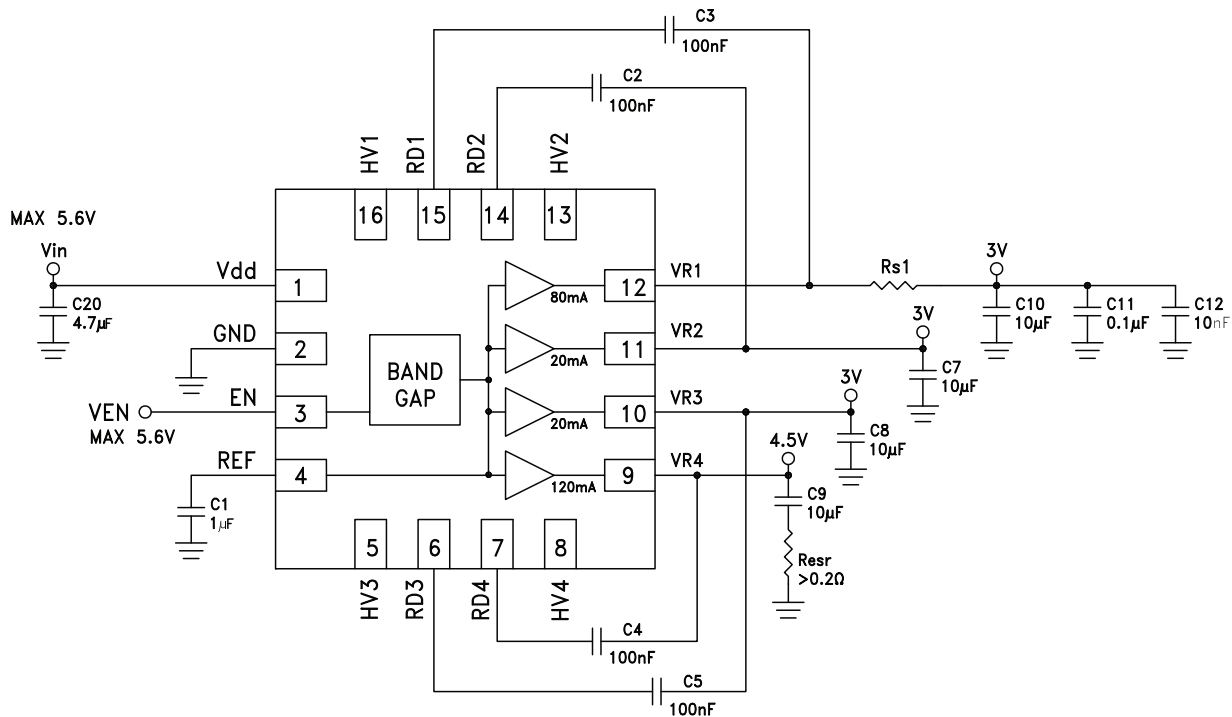

The specified noise performance requires the 1µF decoupling capacitor between pins REF and GND (C1) and the 100nF capacitors connected between output VRx (x=1,2,3,4) and the respective RDx pin (C2, C3, C4 and C5). If noise performance is not critical for a particular output, the 100nF capacitor can be omitted for the respective regulator. In this case, noise spectral density will typically increase by a factor of 20X at 10kHz. The 1µF REF capacitor causes a 25ms typical turn-on start-up time.

### Stability

Two approaches are recommended to manage the stability of the high-current regulators VR1 and VR4. If only one decoupling capacitor is used at the output, the capacitor series resistance Resr must be between 0.2 Ohm and 2 Ohm to insure stability across all loading conditions. This is shown at output VR4 in the application schematic. Note that ceramic capacitors typically have much lower Resr (as low as 0.02 Ohm at resonance) hence they will need a series resistor to insure stability.

In the case when several capacitors are connected at the output (which is often the case with noise and spurious sensitive circuits), an alternate approach is to insert a small resistor in series with the load but after the 100nF feedback capacitor. This is shown by Rs1 at the VR1 output in the application schematic. The minimum resistor value is 0.1 Ohm, while the maximum value is set by the acceptable output voltage drop.

Due to the lower current, regulators VR2 and VR3 do not have special stability requirements. Typical 10µF ceramic capacitor ESR of 0.02 Ohm is sufficient for their stability.



## QUAD LOW NOISE HIGH PSRR LINEAR VOLTAGE REGULATOR

### Output Voltage Adjust

There are several ways to adjust the output voltage for each regulator. A 5V setting for any output can be achieved by grounding the respective HVx (x=1,2,3,4) pin. Any other value requires an external resistor, connected between RDx and GND for a voltage higher than the default, or between VRx and RDx for a voltage lower than the default. The figures below show the values of the internal resistive dividers that set the default output voltage a. for 3V and b. for 4.5V and two examples of two different voltage settings: c. shows a default 3V output changed to 3.3V by connecting a 220k Ohm resistor between RDx and GND, while d. shows the same output adjusted to 2.5V by connecting a 120k Ohm resistor between VRx and RDx.

The internal resistors have a temperature coefficient (TempCo) of +270ppm/°C. When the default output voltage is modified by using an external resistor with a different TempCo, the temperature behavior of the respective output will differ from this specification, although the difference will likely be very small.

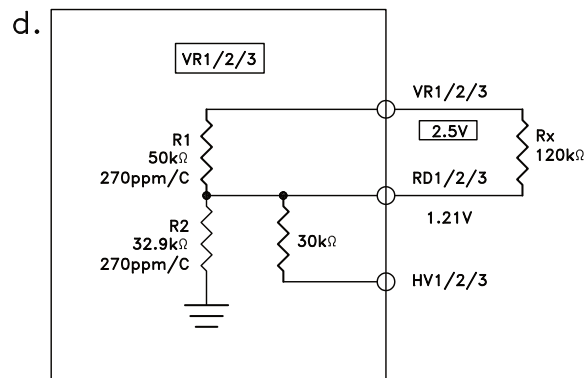
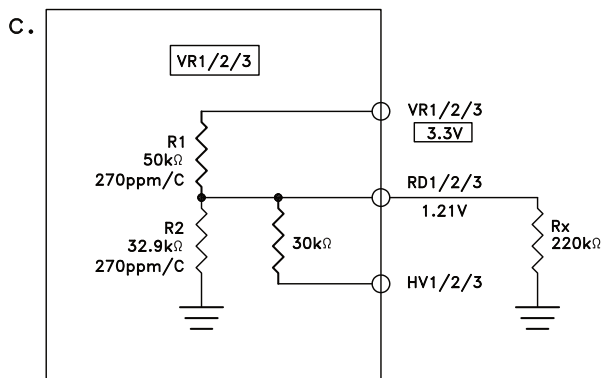
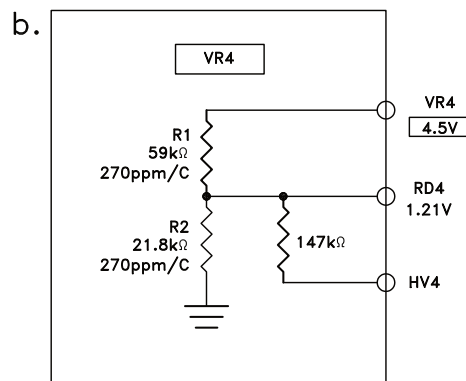
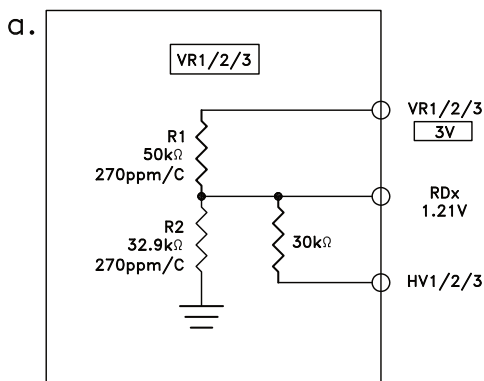

$$VRX \approx VREF \times \left( 1 + \frac{R1 \times (R2 + RX)}{R2 \times RX} \right)$$

For  $VRx > VRx\_default$ ;  
 $X = 1, 2, 3, 4$   
 $VREF = 1.21$  Resistor values in  $K\Omega$   
 $VRx\_default = 3V$  for  $VR1, VR2$  &  $VR3$   
 $VRx\_default = 4.5V$  for  $VR4$

$$VRX \approx VREF \times \left( 1 + \frac{R1 \times RX}{R2 \times (R1 + RX)} \right)$$

For  $VRx < VRx\_default$ ;  
 $X = 1, 2, 3, 4$   
 $VREF = 1.21$  Resistor values in  $K\Omega$





**QUAD LOW NOISE HIGH PSRR  
LINEAR VOLTAGE REGULATOR**

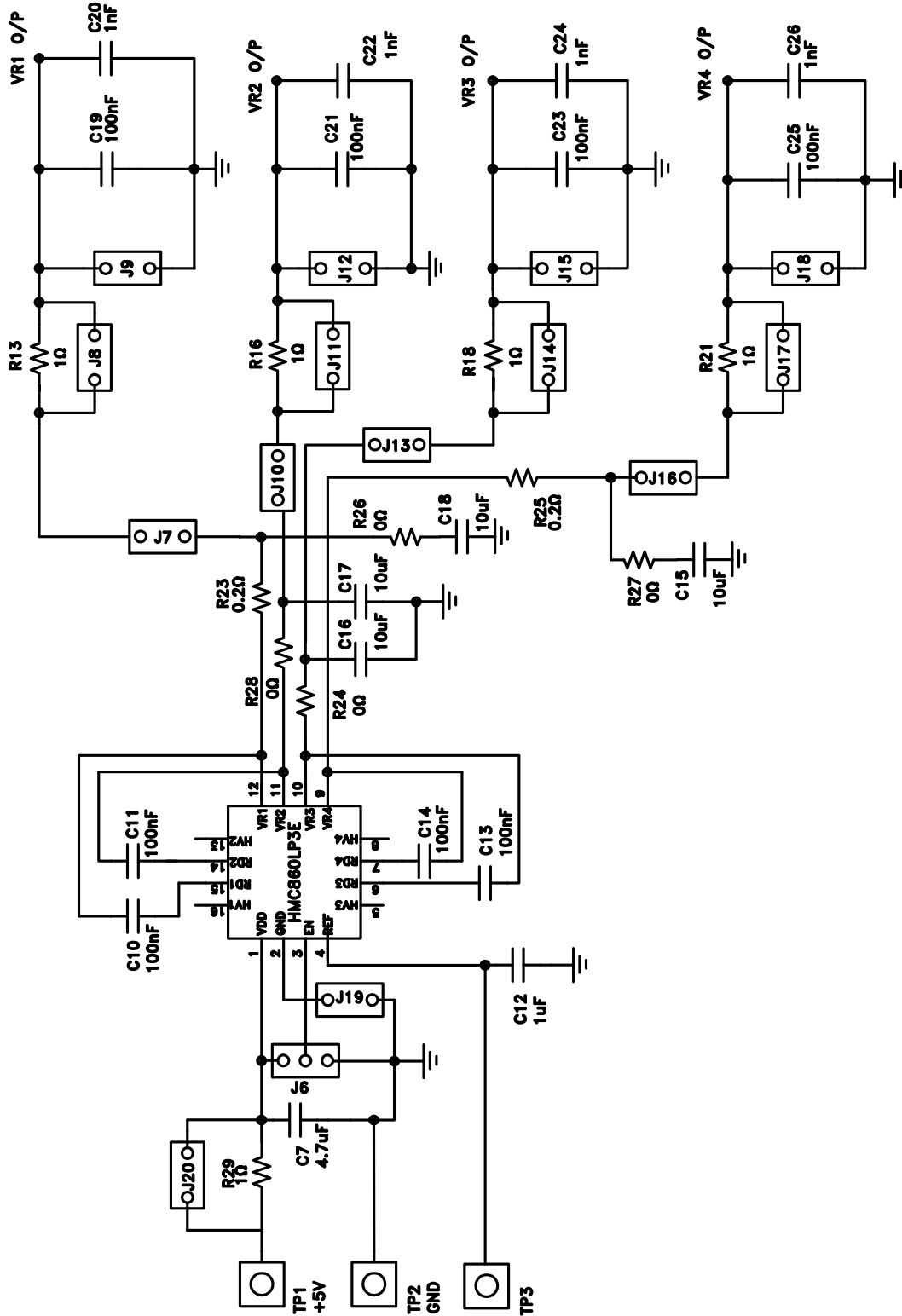

**Evaluation Schematic**

Information furnished by Analog Devices is believed to be accurate and reliable. However, no responsibility is assumed by Analog Devices for its use, nor for any infringements of patents or other rights of third parties that may result from its use. Specifications subject to change without notice. No license is granted by implication or otherwise under any patent or patent rights of Analog Devices. Trademarks and registered trademarks are the property of their respective owners.

For price, delivery, and to place orders: Analog Devices, Inc., One Technology Way, P.O. Box 9106, Norwood, MA 02062-9106 Phone: 781-329-4700 • Order online at [www.analog.com](http://www.analog.com) Application Support: Phone: 1-800-ANALOG-D

**QUAD LOW NOISE HIGH PSRR  
LINEAR VOLTAGE REGULATOR**



**Evaluation PCB**

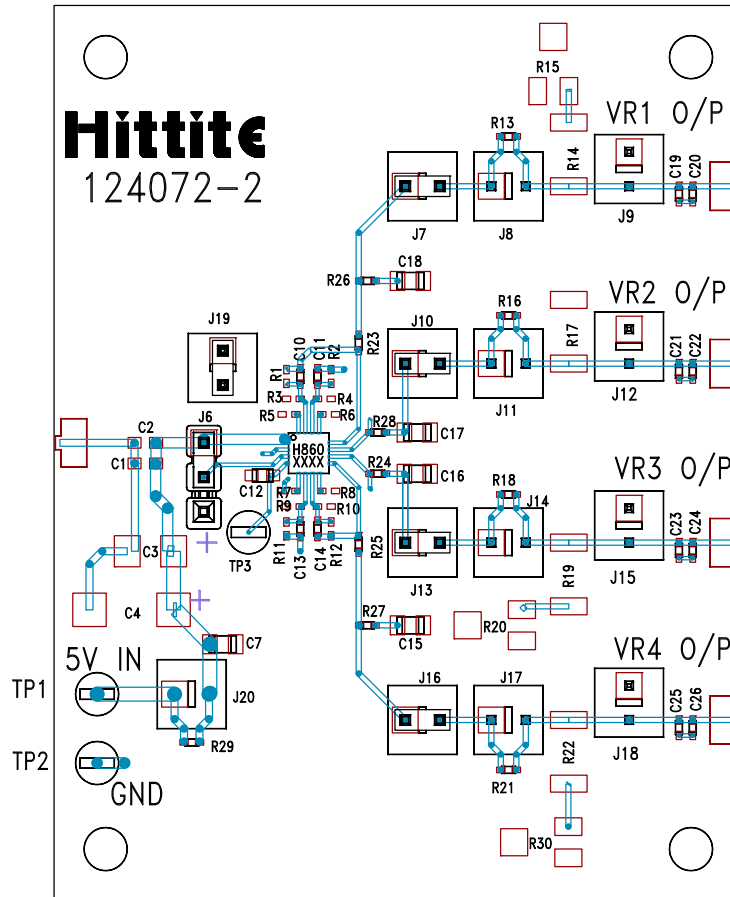

**List of Materials for Evaluation PCB 124352 [1]**

Item	Description
J7 - J20	2 Pos Vertical TIN
C7	4.7 $\mu$ F Capacitor, 0805 Pkg.
C10, C11, C13, C14, C19, C21, C23, C25	100 nF Capacitor, 0402 Pkg.
C12	1.0 $\mu$ F Capacitor, 0603 Pkg.
C15 - C18	10 $\mu$ F Capacitor, 0805 Pkg.
C20, C22, C24, C26	1000 pF Capacitor, 0402 Pkg.
R13, R16, R18, R21, R29	1 Ohm Resistor, 0402 Pkg.
R23, R25	0.2 Ohm Resistor, 0402 Pkg.
R24, R26 - R28	0 Ohm Resistor, 0402 Pkg.
TP1 - TP3	Test Point PC Compact
U1	HMC860LP3E Quad Regulator

Item	Description
PCB [2]	124072 Evaluation PCB

[1] Reference this number when ordering complete evaluation PCB

[2] Circuit Board Material: Rogers 4350 or FR4

A sufficient number of via holes should be used to connect the top and bottom ground planes. The evaluation circuit board shown is available from Hittite upon request.

Information furnished by Analog Devices is believed to be accurate and reliable. However, no responsibility is assumed by Analog Devices for its use, nor for any infringements of patents or other rights of third parties that may result from its use. Specifications subject to change without notice. No license is granted by implication or otherwise under any patent or patent rights of Analog Devices. Trademarks and registered trademarks are the property of their respective owners.

For price, delivery, and to place orders: Analog Devices, Inc., One Technology Way, P.O. Box 9106, Norwood, MA 02062-9106 Phone: 781-329-4700 • Order online at [www.analog.com](http://www.analog.com) Application Support: Phone: 1-800-ANALOG-D

## X-ON Electronics

Largest Supplier of Electrical and Electronic Components

*Click to view similar products for [Power Management IC Development Tools](#) category:*

*Click to view products by [Analog Devices](#) manufacturer:*

Other Similar products are found below :

[EVAL-ADM1168LQEBZ](#) [EVB-EP5348UI](#) [MIC23451-AAAYFL EV](#) [MIC5281YMME EV](#) [DA9063-EVAL](#) [ADP122-3.3-EVALZ](#) [ADP130-0.8-EVALZ](#) [ADP130-1.2-EVALZ](#) [ADP130-1.5-EVALZ](#) [ADP130-1.8-EVALZ](#) [ADP1714-3.3-EVALZ](#) [ADP1716-2.5-EVALZ](#) [ADP1740-1.5-EVALZ](#) [ADP1752-1.5-EVALZ](#) [ADP1828LC-EVALZ](#) [ADP1870-0.3-EVALZ](#) [ADP1871-0.6-EVALZ](#) [ADP1873-0.6-EVALZ](#) [ADP1874-0.3-EVALZ](#) [ADP1882-1.0-EVALZ](#) [ADP199CB-EVALZ](#) [ADP2102-1.25-EVALZ](#) [ADP2102-1.875EVALZ](#) [ADP2102-1.8-EVALZ](#) [ADP2102-2-EVALZ](#) [ADP2102-3-EVALZ](#) [ADP2102-4-EVALZ](#) [ADP2106-1.8-EVALZ](#) [ADP2147CB-110EVALZ](#) [AS3606-DB](#) [BQ24010EVM](#) [BQ24075TEVM](#) [BQ24155EVM](#) [BQ24157EVM-697](#) [BQ24160EVM-742](#) [BQ24296MEVM-655](#) [BQ25010EVM](#) [BQ3055EVM](#) [NCV891330PD50GEVB](#) [ISLUSBI2CKIT1Z](#) [LM2744EVAL](#) [LM2854EVAL](#) [LM3658SD-AEV/NOPB](#) [LM3658SDEV/NOPB](#) [LM3691TL-1.8EV/NOPB](#) [LM4510SDEV/NOPB](#) [LM5033SD-EVAL](#) [LP38512TS-1.8EV](#) [EVAL-ADM1186-1MBZ](#) [EVAL-ADM1186-2MBZ](#)