

FEATURES

Superior Replacement for Other 1.2 V References
Wide Operating Range: 50 μ A to 5 mA
Low Power: 60 μ W Total P_D at 50 μ A
Low Temperature Coefficient:
10 ppm/ $^{\circ}$ C Max, 0 $^{\circ}$ C to 70 $^{\circ}$ C (AD589M)
2-Terminal Zener Operation
Low Output Impedance: 0.6 Ω
No Frequency Compensation Required
Low Cost
MIL-STD-883 Compliant Versions Available

FUNCTIONAL BLOCK DIAGRAMS

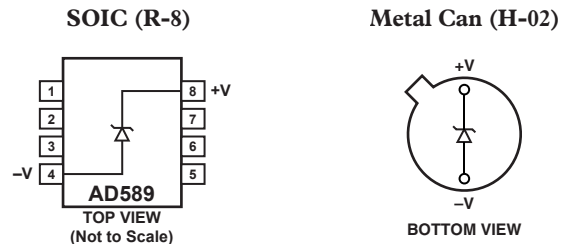

PRODUCT DESCRIPTION

The AD589 is a 2-terminal, low cost, temperature compensated band gap voltage reference that provides a fixed 1.23 V output voltage for input currents between 50 μ A and 5.0 mA.

The high stability of the AD589 is primarily dependent upon the matching and thermal tracking of the on-chip components. Analog Devices' precision bipolar processing and thin-film technology combine to provide excellent performance at low cost.

Additionally, the active circuit produces an output impedance 10 \times lower than the typical low-TC Zener diodes. This feature allows operation with no external components required to maintain full accuracy under changing load conditions.

The AD589 is available in seven versions. The AD589J, AD589K, AD589L, and AD589M grades are specified for 0 $^{\circ}$ C to +70 $^{\circ}$ C operation, while the AD589S and AD589T grades are rated for the full -55 $^{\circ}$ C to +125 $^{\circ}$ C temperature range. All grades are available in a metal can (H-02) package. The AD589J is also available in an 8-lead SOIC package.

PRODUCT HIGHLIGHTS

1. The AD589 is a 2-terminal device that delivers a constant reference voltage for a wide range of input current.
2. Output impedance of 0.6 Ω and temperature coefficients as low as 10 ppm/ $^{\circ}$ C ensure stable output voltage over a wide range of operating conditions.
3. The AD589 can be operated as a positive or negative reference. Floating operation is also possible.
4. The AD589 will operate with a total current as low as 50 μ A (60 μ W total power dissipation), ideal for battery-powered instrument applications.
5. The AD589 is an exact replacement for other 1.2 V references, offering superior temperature performance and reduced sensitivity to capacitive loading.
6. The AD589 is available in versions compliant with MIL-STD-883. Consult factory for 883 data sheet.

REV. C

Information furnished by Analog Devices is believed to be accurate and reliable. However, no responsibility is assumed by Analog Devices for its use, nor for any infringements of patents or other rights of third parties that may result from its use. No license is granted by implication or otherwise under any patent or patent rights of Analog Devices. Trademarks and registered trademarks are the property of their respective owners.

AD589—SPECIFICATIONS (Typical @ $I_{IN} = 500 \mu\text{A}$ and $T_A = 25^\circ\text{C}$, unless otherwise noted.)

Model	AD589JH/ AD589JR			AD589KH			AD589LH			AD589MH			Unit
	Min	Typ	Max	Min	Typ	Max	Min	Typ	Max	Min	Typ	Max	
OUTPUT VOLTAGE, $T_A = 25^\circ\text{C}$	1.200	1.235	1.250	1.200	1.235	1.250	1.200	1.235	1.250	1.200	1.235	1.250	V
OUTPUT VOLTAGE CHANGE VERSUS CURRENT 50 μA to 5 mA			5			5			5			5	mV
DYNAMIC OUTPUT IMPEDANCE		0.6	2		0.6	2		0.6	2		0.6	2	Ω
RMS NOISE VOLTAGE 10 Hz < f < 10 kHz		5			5			5			5		μV
TEMPERATURE COEFFICIENT ¹			100			50			25			10	ppm/ $^\circ\text{C}$
TURN-ON SETTTLING TIME TO 0.1%		25			25			25			25		μs
OPERATING CURRENT ²	0.05		5	0.05		5	0.05		5	0.05		5	mA
OPERATING TEMPERATURE	0		70	0		70	0		70	0		70	$^\circ\text{C}$
PACKAGE OPTION ³ Metal Can (H-02A) SOIC (R-8)			AD589JH AD589JR			AD589KH			AD589LH			AD589MH	

Model	AD589SH			AD589TH			Unit
	Min	Typ	Max	Min	Typ	Max	
OUTPUT VOLTAGE, $T_A = 25^\circ\text{C}$	1.200	1.235	1.250	1.200	1.235	1.250	V
OUTPUT VOLTAGE CHANGE VERSUS CURRENT 50 μA to 5 mA			5			5	mV
DYNAMIC OUTPUT IMPEDANCE		0.6	2		0.6	2	Ω
RMS NOISE VOLTAGE 10 Hz < f < 10 kHz		5			5		μV
TEMPERATURE COEFFICIENT ¹			100			50	ppm/ $^\circ\text{C}$
TURN-ON SETTTLING TIME TO 0.1%		25			25		μs
OPERATING CURRENT ²	0.05		5	0.05		5	mA
OPERATING TEMPERATURE	-55		+125	-55		+125	$^\circ\text{C}$
PACKAGE OPTION ³ Metal Can (H-02) SOIC (R-8)			AD589SH AD589JR			AD589TH	

NOTES

¹See the Voltage Variation versus Temperature section for explanation of temperature coefficient measurement method.

²Optimum performance is obtained at currents below 500 μA . For current operation below 200 μA , stray shunt capacitances should be limited to 20 pF or increased to 1 μF . If strays cannot be avoided, operation at 500 μA and a shunt capacitor of at least 1000 pF are recommended.

³H = Hermetic Metal Can; R = SOIC.

Specifications shown in **boldface** are tested on all production units at final electrical test.

Specifications subject to change without notice.

ABSOLUTE MAXIMUM RATINGS

Current	10 mA
Reverse Current	10 mA
Power Dissipation*	125 mW
Storage Temperature	-65°C to +175°C
Operating Junction Temperature Range	-55°C to +150°C
Lead Temperature (Soldering, 10 sec)	300°C

*Absolute maximum power dissipation is limited by maximum current through the device. Maximum rating at elevated temperatures must be computed assuming $T_j \leq 150^\circ\text{C}$ and $\theta_{JA} = 400 = \text{C/W}$.

AD589 CHIP DIMENSIONS AND PAD LAYOUT

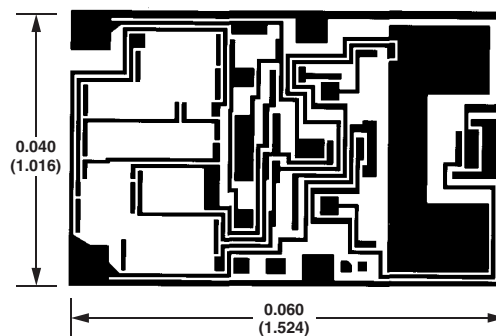

THE AD589 IS AVAILABLE IN CHIP FORM WITH FULLY TESTED AND GUARANTEED SPECIFICATIONS. CONSULT FACTORY FOR AVAILABLE GRADES AND PRICING.

ORDERING GUIDE

Model	Temperature Coefficient (ppm/°C)	Package Description	Package Option	No. of Parts Per Reel/Tray	Temperature Range (°C)
AD589JH	100	Metal Can (TO-51)	H-02	100	0 to +70
AD589JR	100	SOIC-8	R-8	98	0 to +70
AD589JRZ*	100	SOIC-8	R-8	98	0 to +70
AD589JR-REEL	100	SOIC-8	R-8	2,500	0 to +70
AD589JRZ-REEL*	100	SOIC-8	R-8	2,500	0 to +70
AD589JCHIPS	100	DICE	—	25	0 to +70
AD589KH	50	Metal Can (TO-51)	H-02	100	0 to +70
AD589LH	25	Metal Can (TO-51)	H-02	100	0 to +70
AD589MH	10	Metal Can (TO-51)	H-02	100	0 to +70
AD589SH	100	Metal Can (TO-51)	H-02	100	-55 to +125
AD589SH/883B	100	Metal Can (TO-51)	H-02	100	-55 to +125
AD589TH	50	Metal Can (TO-51)	H-02	100	-55 to +125
AD589TH/883B	50	Metal Can (TO-51)	H-02	100	-55 to +125
AD589TCHIPS	50	DICE	—	25	-55 to +125

*Z = Pb-free part

CAUTION

ESD (electrostatic discharge) sensitive device. Electrostatic charges as high as 4000V readily accumulate on the human body and test equipment and can discharge without detection. Although the AD589 features proprietary ESD protection circuitry, permanent damage may occur on devices subjected to high energy electrostatic discharges. Therefore, proper ESD precautions are recommended to avoid performance degradation or loss of functionality.



AD589

UNDERSTANDING THE SPECIFICATIONS

Voltage Variation Versus Temperature

Some confusion exists in the area of defining and specifying reference voltage error over temperature. Historically, references have been characterized using a maximum deviation per degree Centigrade, i.e., 10 ppm/°C. However, because of nonlinearities in temperature characteristics, which originated in standard Zener references (such as S type characteristics), most manufacturers have begun to use a maximum limit error band approach to specify devices. This technique involves measurement of the output at 3, 5, or more different temperatures to guarantee that the output voltage will fall within the given error band. The temperature characteristics of the AD589 consistently follows the curve shown in Figure 1. Three-point measurement guarantees the error band over the specified temperature range. The temperature coefficients specified in the Specifications section represent the slopes of the diagonals of the error band from 25°C to T_{MIN} and 25°C to T_{MAX}.

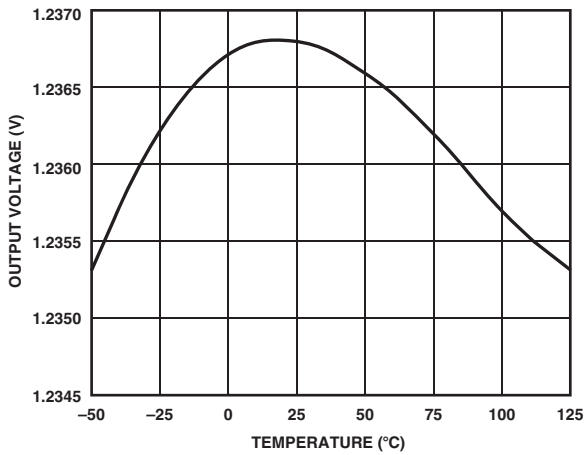

Figure 1. Typical AD589 Temperature Characteristics

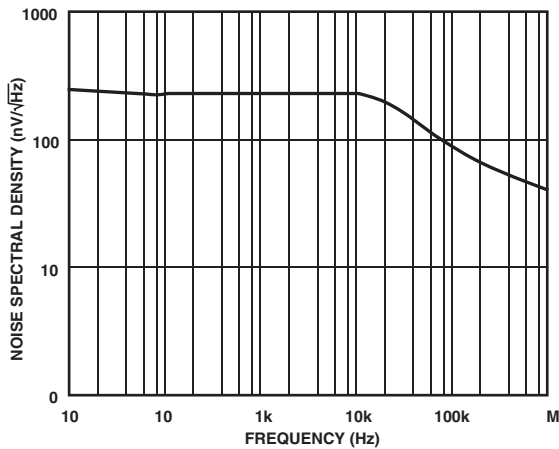

Figure 2. Noise Spectral Density

Dynamic Performance

Many low power instrument manufacturers are becoming increasingly concerned with the turn-on characteristics of the components being used in their systems. Fast turn-on components often enable the end user to keep power off when not needed and yet respond quickly when the power is turned on for operation. Figure 3 displays the turn-on characteristics of the AD589. This characteristic is generated from cold-start operation and represents the true turn-on waveform after an extended period with the supplies off. The figure shows both the coarse and fine transient characteristics of the device; the total settling time to within ± 1 mV is about 25 μ s, and there is no long thermal tail appearing after that point.

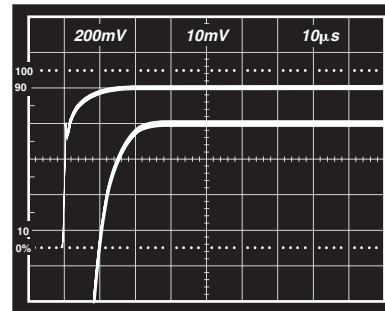

Figure 3. Output Settling Characteristics

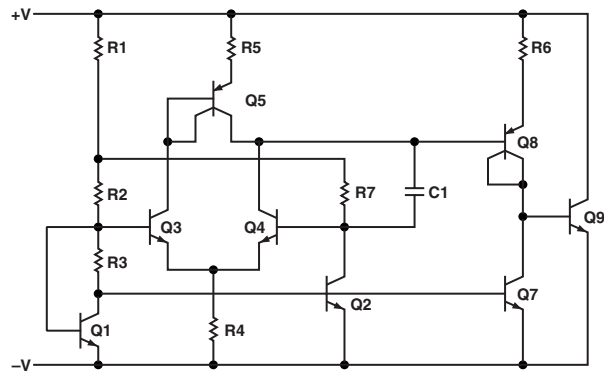

Figure 4. Schematic Diagram

APPLICATION INFORMATION

The AD589 functions as a 2-terminal shunt-type regulator. It provides a constant 1.23 V output for a wide range of input current from 50 μA to 5 mA. Figure 5 shows the simplest configuration for an output voltage of 1.2 V or less. Note that no frequency compensation is required. If additional filtering is desired for ultralow noise applications, minimum recommended capacitance is 1000 pF.

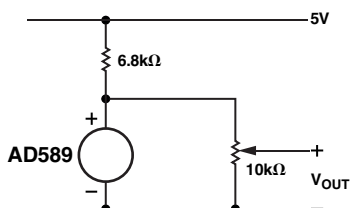

Figure 5. Basic Configuration for 1.2 V or Less

The AD589 can also be used as a building block to generate other values of reference voltage. Figure 6 shows a circuit that produces a buffered 10 V output. Total supply current for this circuit is approximately 2 mA.

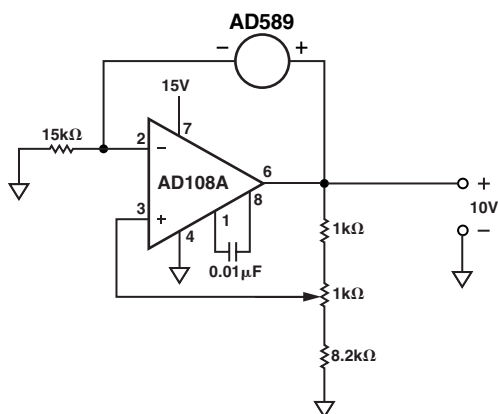
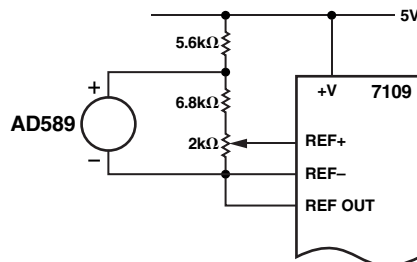
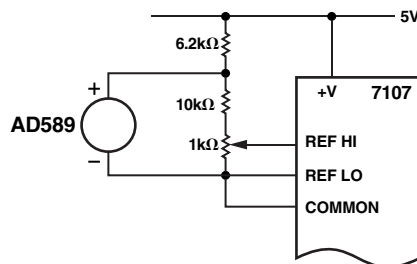

Figure 6. Single-Supply Buffered 10 V Reference

The low power operation of the AD589 makes it ideal for use in battery-operated portable equipment. It is especially useful as a reference for CMOS analog-to-digital converters. Figure 7 shows the AD589 used in conjunction with two popular integrating type CMOS ADCs.



a. With 7109 12-Bit Binary ADC



b. With 7107 Panel Meter ADC

Figure 7. AD589 Used as Reference for CMOS ADCs

The AD589 also is useful as a reference for CMOS multiplying DACs, such as the AD7533. These DACs require a negative reference voltage in order to provide a positive output range. Figure 8 shows the AD589 used to supply an equivalent -1.0 V reference to an AD7533.

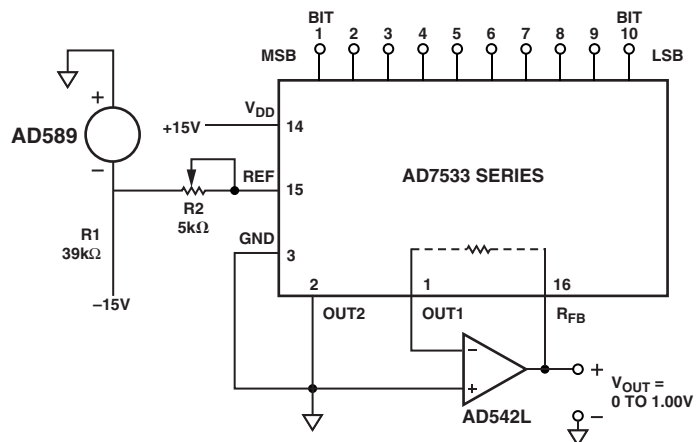
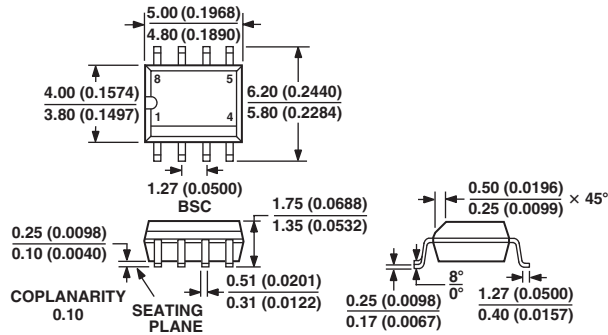

Figure 8. AD589 as Reference for 10-Bit CMOS DAC

OUTLINE DIMENSIONS

8-Lead Standard Small Outline Package [SOIC]
Narrow Body
(R-8)

Dimensions shown in millimeters and (inches)



COMPLIANT TO JEDEC STANDARDS MS-012AA
CONTROLLING DIMENSIONS ARE IN MILLIMETERS; INCH DIMENSIONS
(IN PARENTHESES) ARE ROUNDED-OFF MILLIMETER EQUIVALENTS FOR
REFERENCE ONLY AND ARE NOT APPROPRIATE FOR USE IN DESIGN

2-Pin Metal Header Package [TO-51]
(H-02)

Dimensions shown in inches and (millimeters)

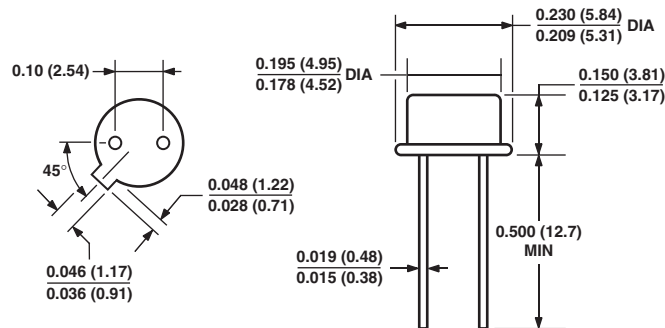

CONTROLLING DIMENSIONS ARE IN INCHES; MILLIMETERS DIMENSIONS
(IN PARENTHESES) ARE ROUNDED-OFF EQUIVALENTS FOR
REFERENCE ONLY AND ARE NOT APPROPRIATE FOR USE IN DESIGN

Revision History

Location	Page
2/04—Data Sheet changed from REV. B to REV. C	
Changes to FEATURES	1
Changes to PRODUCT DESCRIPTION	1
Changes to PRODUCT HIGHLIGHTS	1
Changes to SPECIFICATIONS	2
Added ORDERING GUIDE	3
Updated OUTLINE DIMENSIONS	6

X-ON Electronics

Largest Supplier of Electrical and Electronic Components

Click to view similar products for [Voltage References](#) category:

Click to view products by [Analog Devices](#) manufacturer:

Other Similar products are found below :

[622664A](#) [636116E](#) [748389C](#) [AS431ARTR-E1](#) [NCP431BCSNT1G](#) [NCP432BCSNT1G](#) [NCV431BSNT1G](#) [AP4313UKTR-G1](#)
[TL1431AIYDT](#) [AZ431BR-ATRE1](#) [622668D](#) [NCP432BVSNT1G](#) [5962-8686103XC](#) [NCV431BVDMR2G](#) [AP4306BUKTR-G1](#)
[SC431BVSNT1G](#) [MAX6023EBT30+T](#) [NCV431ASNT1G](#) [LM4040CEM3-5.0/V+T](#) [LT1460KCS3-3#TRM](#) [LT1460KCS3-3.3#TRM](#)
[LT1019AIS8-2.5](#) [LT6660KCDC-10#TRMPBF](#) [LTC6652BHLS8-5#PBF](#) [LTC6652AHLS8-4.096#PBF](#) [LTC6655BHLS8-4.096#PBF](#)
[LT6660HCDC-5#TRMPBF](#) [LM336Z-2.5#PBF](#) [LT1021BMH-10](#) [SC431ILPRAG](#) [TLVH431MIL3T](#) [MAX6023EBT21+T](#) [AP432AQG-7](#)
[ADR4540CRZ](#) [LM4040B25QFTA](#) [TS3325AQPR](#) [REF102AU/2K5](#) [TL4050B25QDBZR](#) [TL4051C12QDCKR](#) [TL431ACZ](#) [KA431SLMF2TF](#)
[KA431SMF2TF](#) [KA431SMFTF](#) [LM385BXZ/NOPB](#) [LM4040QCEM3-3.0/NOPB](#) [LM4041C12ILPR](#) [LM4050AEM3X-5.0/NOPB](#)
[LM4050AIM3X-5.0/NOPB](#) [LM4120AIM5-2.5/NOP](#) [LM431SCCMFX](#)