

FEATURES

Throughput: 100 kSPS
INL: ± 3 LSB Max ($\pm 0.0046\%$ of Full-Scale)
16-Bit Resolution with No Missing Codes
S/(N+D): 87 dB Min @ 10 kHz, 90 dB Typ @ 45 kHz
THD: -96 dB Max @ 10 kHz
Analog Input Voltage Range: 0 V to 2.5 V
Both AC and DC Specifications
No Pipeline Delay
Parallel and Serial 5 V/3 V Interface
SPI®/QSPI™/MICROWIRE™/DSP Compatible
Single 5 V Supply Operation
21 mW Typical Power Dissipation, 21 μ W @ 100 SPS
Power-Down Mode: 7 μ W Max
Package: 48-Lead Quad Flatpack (LQFP)
48-Lead Chip Scale Package (LFCSP)
Pin-to-Pin Compatible with the AD7664

APPLICATIONS

Data Acquisition
Battery-Powered Systems
PCMCIA
Instrumentation
Automatic Test Equipment
Scanners
Medical Instruments
Process Control

GENERAL DESCRIPTION

The AD7660 is a 16-bit, 100 kSPS, charge redistribution SAR, analog-to-digital converter that operates from a single 5 V power supply. The part contains an internal conversion clock, error correction circuits, and both serial and parallel system interface ports.

The AD7660 is hardware factory-calibrated and is comprehensively tested to ensure ac parameters such as signal-to-noise ratio (SNR) and total harmonic distortion (THD), in addition to the more traditional dc parameters of gain, offset, and linearity.

It is fabricated using Analog Devices' high performance, 0.6 micron CMOS process with correspondingly low cost and is available in a 48-lead LQFP and a tiny 48-lead LFCSP with operation specified from -40°C to $+85^{\circ}\text{C}$.

REV. E

Information furnished by Analog Devices is believed to be accurate and reliable. However, no responsibility is assumed by Analog Devices for its use, nor for any infringements of patents or other rights of third parties that may result from its use. No license is granted by implication or otherwise under any patent or patent rights of Analog Devices. Trademarks and registered trademarks are the property of their respective owners.

FUNCTIONAL BLOCK DIAGRAM

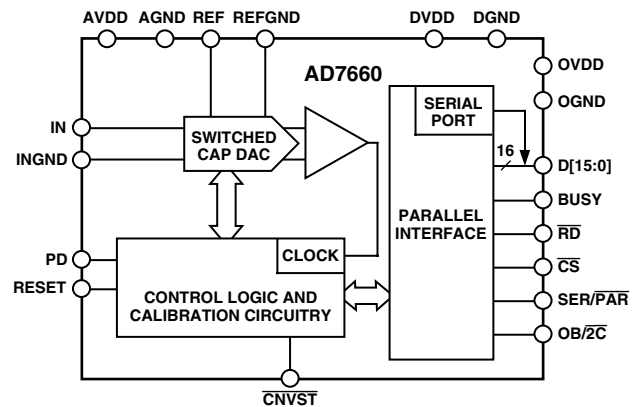

Table I. PuSAR Selection

Type/kSPS	100–250	500–570	800–1000
Pseudo Differential	AD7651 AD7660/AD7661	AD7650/AD7652 AD7664/AD7666	AD7653 AD7667
True Bipolar	AD7663	AD7665	AD7671
True Differential	AD7675	AD7676	AD7677
18-Bit	AD7678	AD7679	AD7674
Simultaneous/ Multichannel		AD7654 AD7655	

PRODUCT HIGHLIGHTS

- Fast Throughput**
 The AD7660 is a 100 kSPS, charge redistribution, 16-bit SAR ADC with internal error correction circuitry.
- Superior INL**
 The AD7660 has a maximum integral nonlinearity of 3 LSBs with no missing 16-bit code.
- Single-Supply Operation**
 The AD7660 operates from a single 5 V supply and only dissipates 21 mW typical. Its power dissipation decreases with the throughput to, for instance, only 21 μ W at a 100 SPS throughput. It consumes 7 μ W maximum when in power-down.
- Serial or Parallel Interface**
 Versatile parallel or 2-wire serial interface arrangement compatible with both 3 V or 5 V logic.

AD7660—SPECIFICATIONS (−40°C to +85°C, AVDD = DVDD = 5 V, OVDD = 2.7 V to 5.25 V, unless otherwise noted.)

Parameter	Conditions	Min	Typ	Max	Unit
RESOLUTION		16			Bits
ANALOG INPUT					
Voltage Range	$V_{IN} - V_{INGND}$	0		V_{REF}	V
Operating Input Voltage	V_{IN}	−0.1		+3	V
	V_{INGND}	−0.1		+0.5	V
Analog Input CMRR	$f_{IN} = 25$ kHz		70		dB
Input Current	100 kSPS Throughput		325		nA
Input Impedance			See Analog Input Section		
THROUGHPUT SPEED					
Complete Cycle				10	μs
Throughput Rate		0		100	kSPS
DC ACCURACY					
Integral Linearity Error		−3		+3	LSB ¹
Differential Linearity Error		−1		+1.75	LSB
No Missing Codes		16			Bits
Transition Noise ²			0.75		LSB
Full-Scale Error ³	REF = 2.5 V		±0.045	±0.08	% of FSR
Unipolar Zero Error ³			±1	±5	LSB
Power Supply Sensitivity	AVDD = 5 V ±5%		±3		LSB
AC ACCURACY					
Signal-to-Noise	$f_{IN} = 10$ kHz	87	90		dB ⁴
	$f_{IN} = 45$ kHz		90		dB
Spurious-Free Dynamic Range	$f_{IN} = 10$ kHz	96			dB
	$f_{IN} = 45$ kHz		100		dB
Total Harmonic Distortion	$f_{IN} = 10$ kHz			−96	dB
	$f_{IN} = 45$ kHz		−100		dB
Signal-to-(Noise+Distortion)	$f_{IN} = 10$ kHz	87			dB
	$f_{IN} = 45$ kHz		90		dB
−3 dB Input Bandwidth	−60 dB Input		30		dB
			820		kHz
SAMPLING DYNAMICS					
Aperture Delay			2		ns
Aperture Jitter			5		ps rms
Transient Response	Full-Scale Step			8	μs
REFERENCE					
External Reference Voltage Range		2.3	2.5	AVDD − 1.85	V
External Reference Current Drain	100 kSPS Throughput		22		μA
POWER SUPPLIES					
Specified Performance					
AVDD		4.75	5	5.25	V
DVDD		4.75	5	5.25	V
OVDD		2.7		5.25	V
Operating Current	100 kSPS Throughput				
AVDD			3.2		mA
DVDD ⁵			1		mA
OVDD ⁵			10		μA
Power Dissipation ⁵	100 kSPS Throughput		21	25	mW
	100 SPS Throughput in Power-Down Mode ^{5, 6}		21		μW
				7	μW
DIGITAL INPUTS					
Logic Levels					
V_{IL}		−0.3		+0.8	V
V_{IH}		+2.0		OVDD + 0.3	V
I_{IL}		−1		+1	μA
I_{IH}		−1		+1	μA
DIGITAL OUTPUTS					
Data Format		Parallel or Serial 16-Bit			
Pipeline Delay		Conversion Results Available Immediately after Completed Conversion			
V_{OL}	$I_{SINK} = 1.6$ mA			0.4	V
V_{OH}	$I_{SOURCE} = -500$ μA	OVDD − 0.6			V

Parameter	Conditions	Min	Typ	Max	Unit
TEMPERATURE RANGE Specified Performance	T_{MIN} to T_{MAX}	-40		+85	°C

NOTES

¹LSB means least significant bit. With the 0 V to 2.5 V input range, one LSB is 38.15 μ V.

²Typical rms noise at worst-case transitions and temperatures.

³See Definition of Specifications section. These specifications do not include the error contribution from the external reference.

⁴All specifications in dB are referred to a full-scale input FS. Tested with an input signal at 0.5 dB below full-scale unless otherwise specified.

⁵Tested in Parallel Reading Mode.

⁶With all digital inputs forced to DVDD or DGND respectively.

Specifications subject to change without notice.

TIMING SPECIFICATIONS (-40°C to $+85^{\circ}\text{C}$, AVDD = DVDD = 5 V, OVDD = 2.7 V to 5.25 V, unless otherwise noted.)

Parameter	Symbol	Min	Typ	Max	Unit
REFER TO FIGURES 11 AND 12					
Convert Pulsewidth	t_1	5			ns
Time between Conversions	t_2	10			μ s
$\overline{\text{CNVST}}$ LOW to BUSY HIGH Delay	t_3			15	ns
BUSY HIGH All Modes Except in Master Serial Read after Convert Mode	t_4			2	μ s
Aperture Delay	t_5		2		ns
End of Conversion to BUSY LOW Delay	t_6	10			ns
Conversion Time	t_7			2	μ s
Acquisition Time	t_8	8			μ s
RESET Pulsewidth	t_9	10			ns
REFER TO FIGURES 13, 14, AND 15 (Parallel Interface Modes)					
$\overline{\text{CNVST}}$ LOW to DATA Valid Delay	t_{10}			2	μ s
DATA Valid to BUSY LOW Delay	t_{11}	45			ns
Bus Access Request to DATA Valid	t_{12}			40	ns
Bus Relinquish Time	t_{13}	5		15	ns
REFER TO FIGURE 16 AND 17 (Master Serial Interface Modes) ¹					
$\overline{\text{CS}}$ LOW to SYNC Valid Delay	t_{14}			10	ns
$\overline{\text{CS}}$ LOW to Internal SCLK Valid Delay	t_{15}			10	ns
$\overline{\text{CS}}$ LOW to SDOUT Delay	t_{16}			10	ns
$\overline{\text{CNVST}}$ LOW to SYNC Delay	t_{17}		500		ns
SYNC Asserted to SCLK First Edge Delay	t_{18}	4			ns
Internal SCLK Period	t_{19}	40		75	ns
Internal SCLK HIGH (INV SCLK Low) ²	t_{20}	30			ns
Internal SCLK LOW (INV SCLK Low) ²	t_{21}	9.5			ns
SDOUT Valid Setup Time	t_{22}	4.5			ns
SDOUT Valid Hold Time	t_{23}	3			ns
SCLK Last Edge to SYNC Delay	t_{24}	3			ns
$\overline{\text{CS}}$ HIGH to SYNC HI-Z	t_{25}			10	ns
$\overline{\text{CS}}$ HIGH to Internal SCLK HI-Z	t_{26}			10	ns
$\overline{\text{CS}}$ HIGH to SDOUT HI-Z	t_{27}			10	ns
BUSY HIGH in Master Serial Read after Convert	t_{28}			3.2	μ s
$\overline{\text{CNVST}}$ LOW to SYNC Asserted Delay	t_{29}		1.5		μ s
SYNC Deasserted to BUSY LOW Delay	t_{30}		50		ns
REFER TO FIGURES 18 AND 20 (Slave Serial Interface Modes) ¹					
External SCLK Setup Time	t_{31}	5			ns
External SCLK Active Edge to SDOUT Delay	t_{32}	3		16	ns
SDIN Setup Time	t_{33}	5			ns
SDIN Hold Time	t_{34}	5			ns
External SCLK Period	t_{35}	25			ns
External SCLK HIGH	t_{36}	10			ns
External SCLK LOW	t_{37}	10			ns

NOTES

¹In serial interface modes, the SYNC, SCLK, and SDOUT timings are defined with a maximum load C_L of 10 pF; otherwise, the load is 60 pF maximum.

²If the polarity of SCLK is inverted, the timing references of SCLK are also inverted.

Specifications subject to change without notice.

AD7660

ABSOLUTE MAXIMUM RATINGS¹

Analog Inputs

IN², REF, INGND, REFGND AVDD + 0.3 V to AGND – 0.3 V

Ground Voltage Differences

AGND, DGND, OGND ±0.3 V

Supply Voltages

AVDD, DVDD, OVDD –0.3 V to +7 V

AVDD to DVDD, AVDD to OVDD ±7 V

DVDD to OVDD ±7 V

Digital Inputs

Except the Databus D(7:4) ... –0.3 V to DVDD + 0.3 V

Databus Inputs D(7:4) –0.3 V to OVDD + 0.3 V

Internal Power Dissipation³ 700 mW

Internal Power Dissipation⁴ 2.5 W

Junction Temperature 150°C

Storage Temperature Range –65°C to +150°C

Lead Temperature Range

(Soldering 10 sec) 300°C

NOTES

¹ Stresses above those listed under Absolute Maximum Ratings may cause permanent damage to the device. This is a stress rating only; functional operation of the device at these or any other conditions above those indicated in the operational section of this specification is not implied. Exposure to absolute maximum rating conditions for extended periods may affect device reliability.

² See Analog Input section.

³ Specification is for device in free air: 48-Lead LQFP: $\theta_{JA} = 91^\circ\text{C}/\text{W}$, $\theta_{JC} = 30^\circ\text{C}/\text{W}$.

⁴ Specification is for device in free air: 48-Lead LFCSP: $\theta_{JA} = 26^\circ\text{C}/\text{W}$.

PIN CONFIGURATION

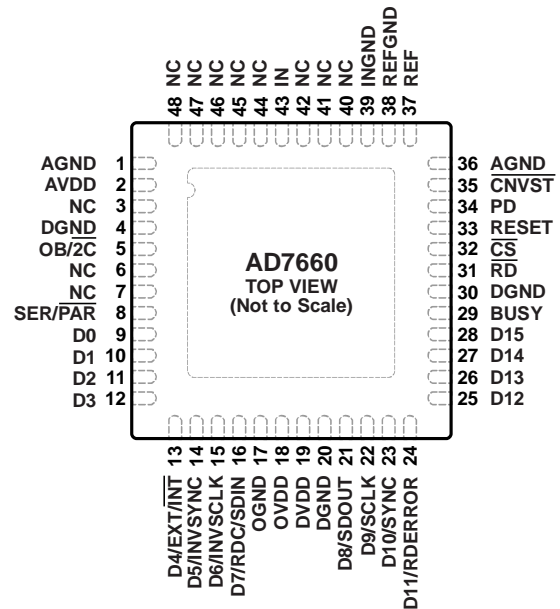

- NOTES**
1. NC = NO CONNECT. DO NOT CONNECT TO THIS PIN.
 2. THE EPAD IS CONNECTED TO GROUND; HOWEVER, THIS CONNECTION IS NOT REQUIRED TO MEET SPECIFIED PERFORMANCE.

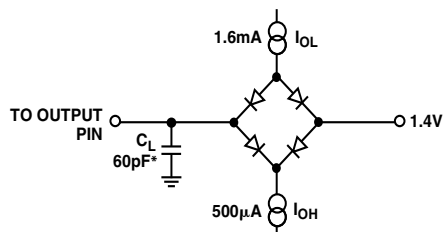

*IN SERIAL INTERFACE MODES, THE SYNC, SCLK, AND SDOUT TIMINGS ARE DEFINED WITH A MAXIMUM LOAD C_L OF 10pF; OTHERWISE, THE LOAD IS 60pF MAXIMUM.

Figure 1. Load Circuit for Digital Interface Timing

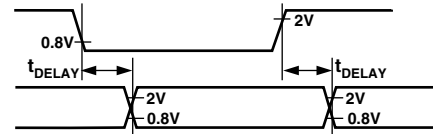

Figure 2. Voltage Reference Levels for Timings

ORDERING GUIDE

Model ¹	Temperature Range	Package Description	Package Option
AD7660ASTZ	–40°C to +85°C	48-Lead LQFP	ST-48
AD7660ASTZRL	–40°C to +85°C	48-Lead LQFP	ST-48
AD7660ACPZRL	–40°C to +85°C	48-Lead LFCSP	CP-48-4

NOTES

¹Z = RoHS Compliant Part.

CAUTION

ESD (electrostatic discharge) sensitive device. Electrostatic charges as high as 4000 V readily accumulate on the human body and test equipment and can discharge without detection. Although the AD7660 features proprietary ESD protection circuitry, permanent damage may occur on devices subjected to high energy electrostatic discharges. Therefore, proper ESD precautions are recommended to avoid performance degradation or loss of functionality.



PIN FUNCTION DESCRIPTIONS

Pin No.	Mnemonic	Type	Description
1	AGND	P	Analog Power Ground Pin
2	AVDD	P	Input Analog Power Pins. Nominally 5 V.
3, 6, 7, 40–42, 44–48	NC		No Connect
4	DGND	DI	Must Be Tied to Digital Ground
5	OB/2C	DI	Straight Binary/Binary Twos Complement. When OB/2C is HIGH, the digital output is straight binary; when LOW, the MSB is inverted resulting in a twos complement output from its internal shift register.
8	SER/PAR	DI	Serial/Parallel Selection Input. When LOW, the Parallel Port is selected; when HIGH, the Serial Interface Mode is selected and some bits of the DATA bus are used as a Serial Port.
9–12	D[0:3]	DO	Bit 0 to Bit 3 of the Parallel Port Data Output Bus. These pins are always outputs regardless of the state of SER/PAR.
13	D4 or EXT/INT	DI/O	When SER/PAR is LOW, this output is used as the Bit 4 of the Parallel Port Data Output Bus. When SER/PAR is HIGH, this input, part of the Serial Port, is used as a digital select input for choosing the internal or an external data clock. With EXT/INT tied LOW, the internal clock is selected on the SCLK output. With EXT/INT set to a logic HIGH, output data is synchronized to an external clock signal connected to the SCLK input.
14	D5 or INVSYNC	DI/O	When SER/PAR is LOW, this output is used as the Bit 5 of the Parallel Port Data Output Bus. When SER/PAR is HIGH, this input, part of the Serial Port, is used to select the active state of the SYNC signal. When LOW, SYNC is active HIGH. When HIGH, SYNC is active LOW.
15	D6 or INVCLK	DI/O	When SER/PAR is LOW, this output is used as the Bit 6 of the Parallel Port Data Output Bus. When SER/PAR is HIGH, this input, part of the Serial Port, is used to invert the SCLK signal. It is active in both Master and Slave Modes.
16	D7 or RDC/SDIN	DI/O	When SER/PAR is LOW, this output is used as the Bit 7 of the Parallel Port Data Output Bus. When SER/PAR is HIGH, this input, part of the Serial Port, is used as either an external data input or a Read Mode selection input depending on the state of EXT/INT. When EXT/INT is HIGH, RDC/SDIN could be used as a data input to daisy-chain the conversion results from two or more ADCs onto a single SDOUT line. The digital data level on SDIN is output on DATA with a delay of 16 SCLK periods after the initiation of the read sequence. When EXT/INT is LOW, RDC/SDIN is used to select the Read Mode. When RDC/SDIN is HIGH, the data is output on SDOUT during conversion. When RDC/SDIN is LOW, the data is output on SDOUT only when the conversion is complete.
17	OGND	P	Input/Output Interface Digital Power Ground
18	OVDD	P	Input/Output Interface Digital Power. Nominally at the same supply as the supply of the host interface (5 V or 3 V).
19	DVDD	P	Digital Power. Nominally at 5 V.
20	DGND	P	Digital Power Ground
21	D8 or SDOUT	DO	When SER/PAR is LOW, this output is used as Bit 8 of the Parallel Port Data Output Bus. When SER/PAR is HIGH, this output, part of the Serial Port, is used as a serial data output synchronized to SCLK. Conversion results are stored in an on-chip register. The AD7660 provides the conversion result, MSB first, from its internal shift register. The DATA format is determined by the logic level of OB/2C. In Serial Mode, when EXT/INT is LOW, SDOUT is valid on both edges of SCLK. In Serial Mode, when EXT/INT is HIGH: If INVSCLK is LOW, SDOUT is updated on the SCLK rising edge and valid on the next falling edge. If INVSCLK is HIGH, SDOUT is updated on the SCLK falling edge and valid on the next rising edge.

PIN FUNCTION DESCRIPTIONS (continued)

Pin No.	Mnemonic	Type	Description
22	D9 or SCLK	DI/O	When $\overline{\text{SER/}\overline{\text{PAR}}}$ is LOW, this output is used as Bit 9 of the Parallel Port Data Output Bus. When $\overline{\text{SER/}\overline{\text{PAR}}}$ is HIGH, this pin, part of the Serial Port, is used as a serial data clock input or output, dependent upon the logic state of the $\overline{\text{EXT/}\overline{\text{INT}}}$ pin. The active edge where the data SDO _{OUT} is updated depends upon the logic state of the $\overline{\text{INV}}\overline{\text{SCLK}}$ pin.
23	D10 or SYNC	DO	When $\overline{\text{SER/}\overline{\text{PAR}}}$ is LOW, this output is used as Bit 10 of the Parallel Port Data Output Bus. When $\overline{\text{SER/}\overline{\text{PAR}}}$ is HIGH, this output, part of the Serial Port, is used as a digital output frame synchronization for use with the internal data clock ($\overline{\text{EXT/}\overline{\text{INT}}} = \text{Logic LOW}$). When a read sequence is initiated and $\overline{\text{INV}}\overline{\text{SYNC}}$ is LOW, SYNC is driven HIGH and remains HIGH while SDO _{OUT} output is valid. When a read sequence is initiated and $\overline{\text{INV}}\overline{\text{SYNC}}$ is HIGH, SYNC is driven LOW and remains LOW while SDO _{OUT} output is valid.
24	D11 or RDERROR	DO	When $\overline{\text{SER/}\overline{\text{PAR}}}$ is LOW, this output is used as the Bit 11 of the Parallel Port Data Output Bus. When $\overline{\text{SER/}\overline{\text{PAR}}}$ is HIGH and $\overline{\text{EXT/}\overline{\text{INT}}}$ is HIGH, this output, part of the Serial Port, is used as an incomplete read error flag. In Slave Mode, when a data read is started and not complete when the following conversion is complete, the current data is lost and RDERROR is pulsed HIGH.
25–28	D[12:15]	DO	Bit 12 to Bit 15 of the Parallel Port Data Output Bus. These pins are always outputs regardless of the state of $\overline{\text{SER/}\overline{\text{PAR}}}$.
29	BUSY	DO	Busy Output. Transitions HIGH when a conversion is started and remains HIGH until the conversion is complete and the data is latched into the on-chip shift register. The falling edge of BUSY could be used as a data-ready clock signal.
30	DGND	P	Must Be Tied to Digital Ground
31	$\overline{\text{RD}}$	DI	Read Data. When $\overline{\text{CS}}$ and $\overline{\text{RD}}$ are both LOW, the interface parallel or serial output bus is enabled.
32	$\overline{\text{CS}}$	DI	Chip Select. When $\overline{\text{CS}}$ and $\overline{\text{RD}}$ are both LOW, the interface parallel or serial output bus is enabled. $\overline{\text{CS}}$ is also used to gate the external clock.
33	RESET	DI	Reset Input. When set to a logic HIGH, reset the AD7660. Current conversion, if any, is aborted.
34	PD	DI	Power-Down Input. When set to a logic HIGH, power consumption is reduced and conversions are inhibited after the current one is completed.
35	$\overline{\text{CNVST}}$	DI	Start Conversion. If $\overline{\text{CNVST}}$ is HIGH when the acquisition phase (t_g) is complete, the next falling edge on $\overline{\text{CNVST}}$ puts the internal sample-and-hold into the hold state and initiates a conversion. This mode is the most appropriate if low sampling jitter is desired. If $\overline{\text{CNVST}}$ is LOW when the acquisition phase (t_g) is complete, the internal sample-and-hold is put into the hold state and a conversion is immediately started.
36	AGND	P	Must Be Tied to Analog Ground
37	REF	AI	Reference Input Voltage
38	REFGND	AI	Reference Input Analog Ground
39	INGND	AI	Analog Input Ground
43	IN EPAD	AI	Primary Analog Input with a Range of 0 V to V_{REF} Exposed Pad. The EPAD is connected to ground; however, this connection is not required to meet specified performance.

NOTES

AI = Analog Input
DI = Digital Input
DI/O = Bidirectional Digital
DO = Digital Output
P = Power

DEFINITION OF SPECIFICATIONS**Integral Nonlinearity Error (INL)**

Linearity error refers to the deviation of each individual code from a line drawn from “negative full scale” through “positive full scale.” The point used as negative full scale occurs 1/2 LSB before the first code transition. Positive full scale is defined as a level 1 1/2 LSB beyond the last code transition. The deviation is measured from the middle of each code to the true straight line.

Differential Nonlinearity Error (DNL)

In an ideal ADC, code transitions are 1 LSB apart. Differential nonlinearity is the maximum deviation from this ideal value. It is often specified in terms of resolution for which no missing codes are guaranteed.

Full-Scale Error

The last transition (from 011 . . . 10 to 011 . . . 11 in twos complement coding) should occur for an analog voltage 1 1/2 LSB below the nominal full scale (2.49994278 V for the 0 V–2.5 V range). The full-scale error is the deviation of the actual level of the last transition from the ideal level.

Unipolar Zero Error

The first transition should occur at a level 1/2 LSB above analog ground (19.073 μ V for the 0 V–2.5 V range). Unipolar zero error is the deviation of the actual transition from that point.

Spurious-Free Dynamic Range (SFDR)

The difference, in decibels (dB), between the rms amplitude of the input signal and the peak spurious signal.

Effective Number of Bits (ENOB)

ENOB is a measurement of the resolution with a sine wave input. It is related to $S/[N+D]$ by the following formula:

$$ENOB = \left(S/[N+D]_{dB} - 1.76 \right) / 6.02$$

and is expressed in bits.

Total Harmonic Distortion (THD)

THD is the ratio of the rms sum of the first five harmonic components to the rms value of a full-scale input signal and is expressed in decibels.

Signal-to-Noise Ratio (SNR)

SNR is the ratio of the rms value of the actual input signal to the rms sum of all other spectral components below the Nyquist frequency, excluding harmonics and dc. The value for SNR is expressed in decibels.

Signal-to-(Noise + Distortion) Ratio (S/[N+D])

$S/(N+D)$ is the ratio of the rms value of the actual input signal to the rms sum of all other spectral components below the Nyquist frequency, including harmonics but excluding dc. The value for $S/(N+D)$ is expressed in decibels.

Aperture Delay

Aperture delay is a measure of the acquisition performance and is measured from the falling edge of the \overline{CNVST} input to when the input signal is held for a conversion.

Transient Response

The time required for the AD7660 to achieve its rated accuracy after a full-scale step function is applied to its input.

Overvoltage Recovery

The time required for the ADC to recover to full accuracy after an analog input signal 150% of full-scale is reduced to 50% of the full-scale value.

AD7660—Typical Performance Characteristics

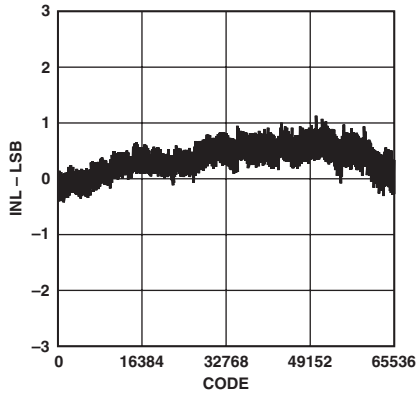

TPC 1. Integral Nonlinearity vs. Code

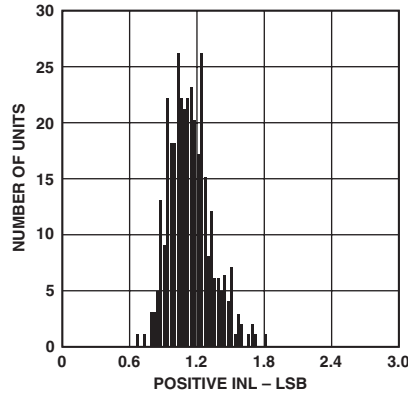

TPC 2. Typical Positive INL Distribution (350 Units)

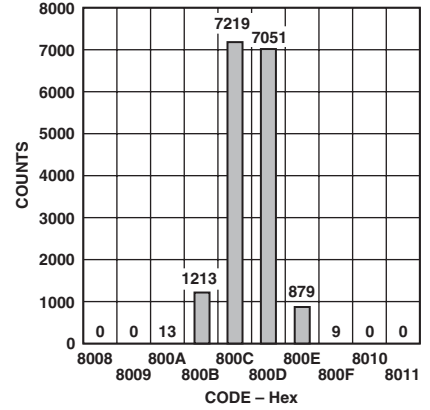

TPC 3. Histogram of 16,384 Conversions of a DC Input at the Code Transition

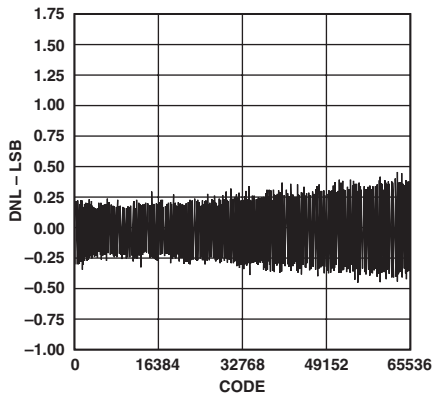

TPC 4. Differential Nonlinearity vs. Code

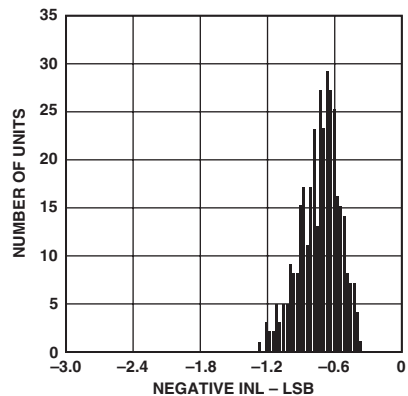

TPC 5. Typical Negative INL Distribution (350 Units)

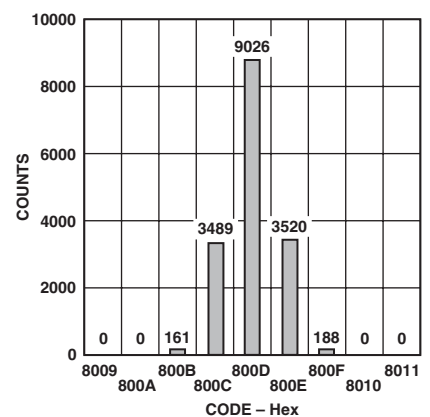

TPC 6. Histogram of 16,384 Conversions of a DC Input at the Code Center

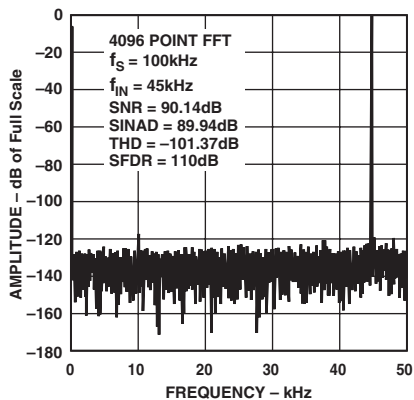

TPC 7. FFT Plot

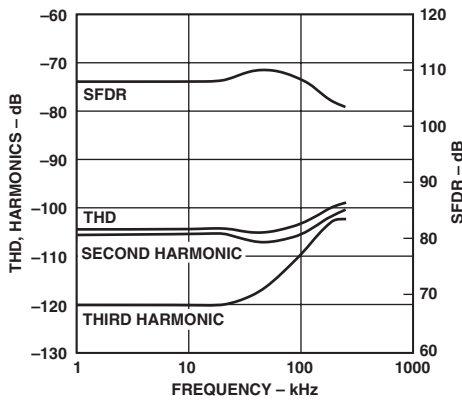

TPC 8. THD, Harmonics, and SFDR vs. Frequency

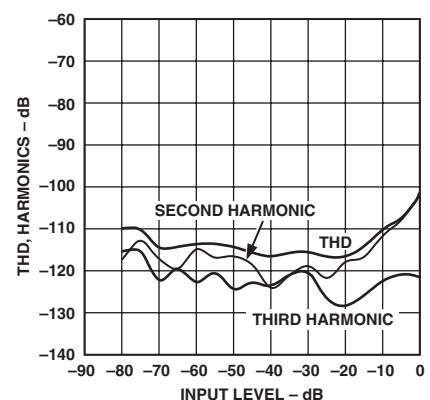

TPC 9. THD, Harmonics vs. Input Level

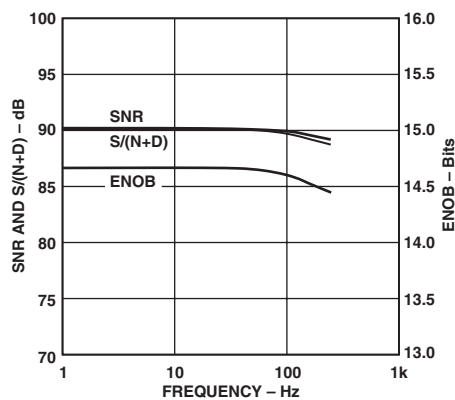

TPC 10. SNR, $S/(N+D)$, and ENOB vs. Frequency

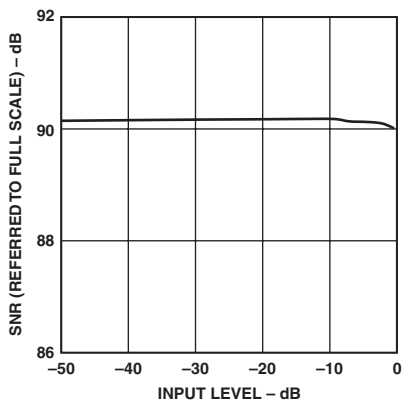

TPC 11. SNR vs. Input Level (Referred to Full Scale)

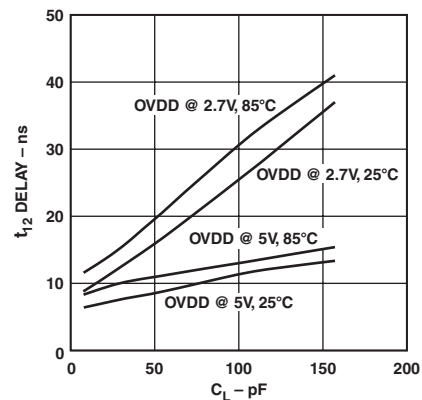

TPC 12. Typical Delay vs. Load Capacitance C_L

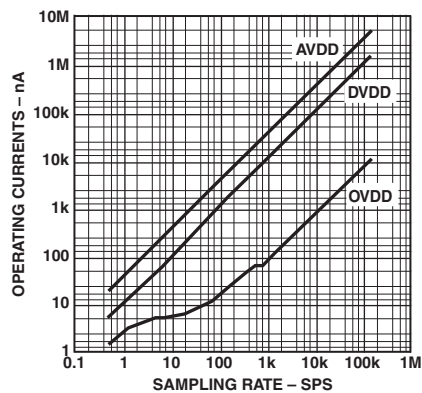

TPC 13. Operating Currents vs. Sample Rate

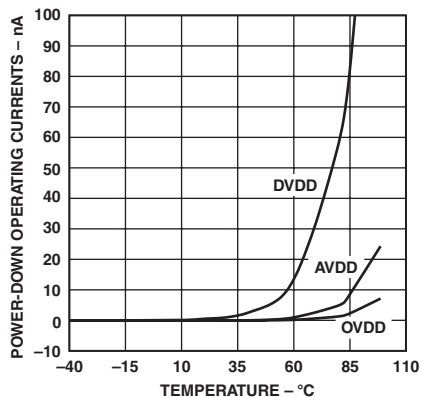

TPC 14. Power-Down Operating Currents vs. Temperature

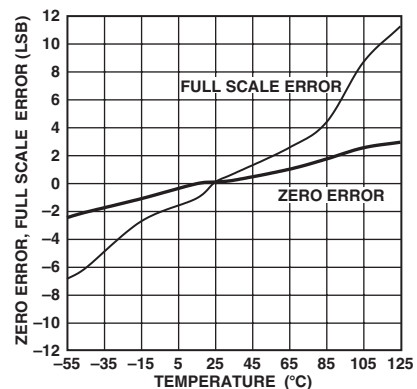

TPC 15. Zero Error, Full Scale vs. Temperature

AD7660

CIRCUIT INFORMATION

The AD7660 is a fast, low power, single-supply, precise 16-bit analog-to-digital converter (ADC). The AD7660 is capable of converting 100,000 samples per second (100 kSPS) and allows power saving between conversions. When operating at 100 SPS, for example, it consumes typically only 21 μ W. This feature makes the AD7660 ideal for battery-powered applications.

The AD7660 provides the user with an on-chip track-and-hold, successive-approximation ADC that does not exhibit any pipeline or latency, making it ideal for multiple multiplexed channel applications.

The AD7660 can be operated from a single 5 V supply and be interfaced to either 5 V or 3 V digital logic. It is housed in a 48-lead LQFP package or a 48-lead LFCSP package that combines space savings and allows flexible configurations as either serial or parallel interface. The AD7660 is pin-to-pin compatible with the AD7664.

CONVERTER OPERATION

The AD7660 is a successive-approximation analog-to-digital converter based on a charge redistribution DAC. Figure 3 shows the simplified schematic of the ADC. The capacitive DAC consists of an array of 16 binary weighted capacitors and an additional LSB capacitor. The comparator's negative input is connected to a "dummy" capacitor of the same value as the capacitive DAC array.

During the acquisition phase, the common terminal of the array tied to the comparator's positive input is connected to AGND via SW_A . All independent switches are connected to the analog input IN. Thus, the capacitor array is used as a sampling capacitor and acquires the analog signal on IN input. Similarly, the dummy capacitor acquires the analog signal on the INGND input.

When the acquisition phase is complete and the \overline{CNVST} input goes or is LOW, a conversion phase is initiated. When the conversion phase begins, SW_A and SW_B are opened first. The capacitor array and the dummy capacitor are then disconnected from the inputs and connected to the REFGND input. Therefore, the differential voltage between IN and INGND captured at the end of the acquisition phase is applied to the comparator inputs, causing the comparator to become unbalanced.

By switching each element of the capacitor array between REFGND or REF, the comparator input varies by binary weighted voltage steps ($V_{REF}/2, V_{REF}/4 \dots V_{REF}/65536$). The control logic toggles these switches, starting with the MSB first, in order to bring the comparator back into a balanced condition. After the completion of this process, the control logic generates the ADC output code and brings BUSY output LOW.

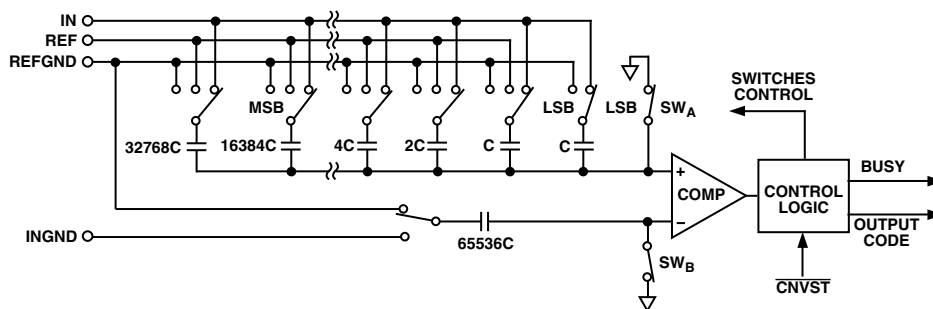

Figure 3. ADC Simplified Schematic

Transfer Functions

Using the $\overline{OB/2C}$ digital input, the AD7660 offers two output codings: straight binary and twos complement. The LSB size is $V_{REF}/65536$, which is about $38.15 \mu\text{V}$. The ideal transfer characteristic for the AD7660 is shown in Figure 4 and Table II.

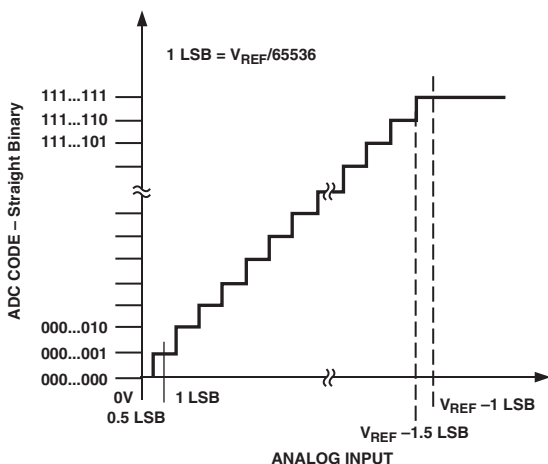

Figure 4. ADC Ideal Transfer Function

Table II. Output Codes and Ideal Input Voltages

Description	Analog Input	Digital Output Code (Hex)	
		Straight Binary	Twos Complement
FSR - 1 LSB	2.499962 V	FFFF ¹	7FFF ¹
FSR - 2 LSB	2.499923 V	FFFE	7FFE
Midscale + 1 LSB	1.250038 V	8001	0001
Midscale	1.25 V	8000	0000
Midscale - 1 LSB	1.249962 V	7FFF	FFFF
-FSR + 1 LSB	38 μV	0001	8001
-FSR	0 V	0000 ²	8000 ²

NOTES

¹This is also the code for overrange analog input ($V_{IN} - V_{INGND}$ above $V_{REF} - V_{REFGND}$).

²This is also the code for underrange analog input (V_{IN} below V_{INGND}).

TYPICAL CONNECTION DIAGRAM

Figure 5 shows a typical connection diagram for the AD7660.

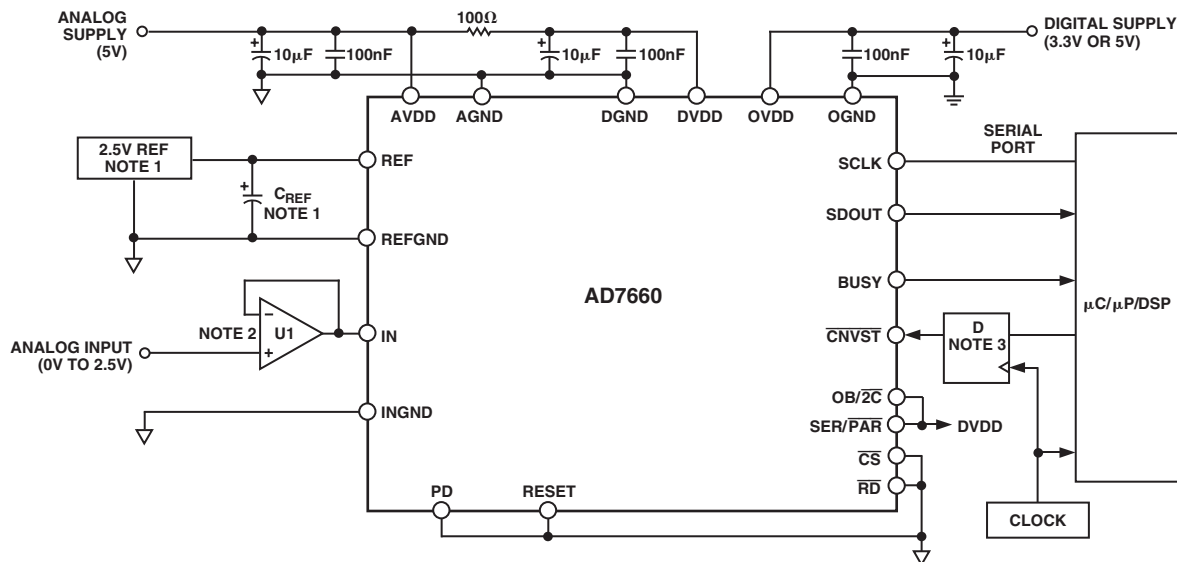

NOTES

1. WITH THE AD780 OR THE ADR291 VOLTAGE REFERENCE, C_{REF} IS $47 \mu\text{F}$. SEE VOLTAGE REFERENCE INPUT SECTION.
2. THE OP184 IS RECOMMENDED.
3. OPTIONAL LOW JITTER \overline{CNVST} .

Figure 5. Typical Connection Diagram

AD7660

Analog Input

Figure 6 shows an equivalent circuit of the input structure of the AD7660.

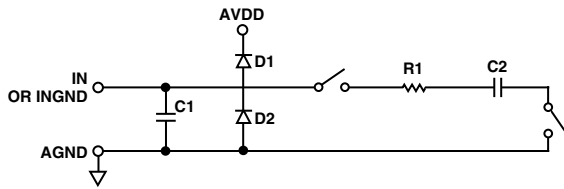

Figure 6. Equivalent Analog Input Circuit

The two diodes D1 and D2 provide ESD protection for the analog inputs IN and INGND. Care must be taken to ensure that the analog input signal never exceeds the supply rails by more than 0.3 V. This will cause these diodes to become forward-biased and start conducting current. These diodes can handle a forward-biased current of 100 mA maximum. For instance, these conditions could eventually occur when the input buffer's (U1) supplies are different from AVDD. In such cases, an input buffer with a short circuit current limitation can be used to protect the part.

This analog input structure allows the sampling of the differential signal between IN and INGND. Unlike other converters, the INGND input is sampled at the same time as the IN input. By using this differential input, small signals common to both inputs are rejected as shown in Figure 7, which represents the typical CMRR over frequency. For instance, by using INGND to sense a remote signal ground, difference of ground potentials between the sensor and the local ADC ground is eliminated.

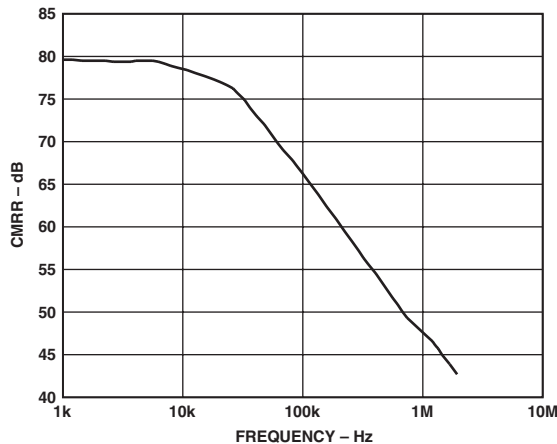

Figure 7. Analog Input CMRR vs. Frequency

During the acquisition phase, the impedance of the analog input IN can be modeled as a parallel combination of capacitor C1 and the network formed by the series connection of R1 and C2. Capacitor C1 is primarily the pin capacitance. The resistor R1 is typically 3242 Ω and is a lumped component made up of some serial resistors and the on resistance of the switches. The capacitor C2 is typically 60 pF and is mainly the ADC sampling capacitor. During the conversion phase, where the switches are opened, the input impedance is limited to C1. It has to be noted that the input impedance of the AD7660, unlike other SAR ADCs, is not a pure capacitance and thus, inherently reduces the kickback transient at the beginning of the acquisition phase. The R1, C2 makes a one-pole low-pass filter with a typical cutoff frequency of 820 kHz that reduces undesirable aliasing effect and limits the noise.

When the source impedance of the driving circuit is low, the AD7660 can be driven directly. Large source impedances will significantly affect the ac performances, especially the total harmonic distortion (THD). The maximum source impedance depends on the amount of THD that can be tolerated. The THD degrades in function of the source impedance and the maximum input frequency as shown in Figure 8.

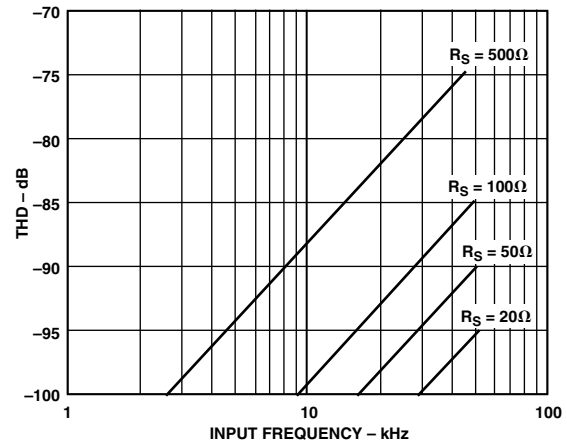

Figure 8. THD vs. Analog Input Frequency and Source Resistance

Driver Amplifier Choice

Although the AD7660 is easy to drive, the driver amplifier needs to meet at least the following requirements:

- The driver amplifier and the AD7660 analog input circuit must be able, together, to settle for a full-scale step of the capacitor array at a 16-bit level (0.0015%). For instance, operation at the maximum throughput of 100 kSPS requires a minimum gain bandwidth product of 5 MHz.
- The noise generated by the driver amplifier needs to be kept as low as possible in order to preserve the SNR and transition noise performance of the AD7660. The noise coming from the driver is filtered by the AD7660 analog input circuit one-pole low-pass filter made by R1 and C2. For instance, a driver with an equivalent input noise of 4 nV/√Hz like the OP184 and configured as a buffer, thus with a noise gain of +1, degrades the SNR by only 0.1 dB.
- The driver needs to have a THD performance suitable to that of the AD7660. TPC 8 gives the THD versus frequency that the driver should preferably exceed.

The SNR degradation due to the amplifier is:

$$SNR_{LOSS} = 20 \log \left(\frac{28}{\sqrt{784 + \frac{\pi}{2} f_{-3dB} (N e_N)^2}} \right)$$

where:

f_{-3dB} is the -3 dB input bandwidth in MHz of the AD7660 (0.82 MHz) or the cutoff frequency of the input filter if any are used.

N is the noise factor of the amplifier (1 if in buffer configuration).

e_N is the equivalent input noise voltage of the op amp in nV/√Hz.

The AD8519, OP162, or the OP184 meet these requirements and are usually appropriate for almost all applications. As an alternative, in very high speed and noise-sensitive applications, the AD8021 with an external compensation capacitor of 10 pF or the AD829 with an external compensation capacitor of 82 pF can be used. This capacitor should have good linearity as an NPO ceramic or mica type. Moreover, the use of a noninverting +1 gain arrangement is recommended and helps to obtain the best signal-to-noise ratio.

Voltage Reference Input

The AD7660 uses an external 2.5 V voltage reference.

The voltage reference input REF of the AD7660 has a dynamic input impedance; it should therefore be driven by a low impedance source with an efficient decoupling between REF and REFGND inputs. This decoupling depends on the choice of the voltage reference but usually consists of a 1 μ F ceramic capacitor and a low ESR tantalum capacitor connected to the REF and REFGND inputs with minimum parasitic inductance. 47 μ F is an appropriate value for the tantalum capacitor when used with one of the recommended reference voltages:

- The low noise, low temperature drift ADR421 and AD780 voltage references
- The low power ADR291 voltage reference
- The low cost AD1582 voltage reference

For applications using multiple AD7660s, it is more effective to buffer the reference voltage with a low noise, very stable op amp like the AD8031.

Care should also be taken with the reference temperature coefficient of the voltage reference that directly affects the full-scale accuracy if this parameter matters. For instance, a ± 15 ppm/ $^{\circ}$ C tempco of the reference changes the full scale by ± 1 LSB/ $^{\circ}$ C.

V_{REF} , as mentioned in the specification table, could be increased to AVDD – 1.85 V. The benefit here is the increased SNR obtained as a result of this increase. Since the input range is defined in terms of V_{REF} , this would essentially increase the range to make it a ± 3 V input range with an AVDD above 4.85 V. The theoretical improvement as a result of this increase in reference is 1.58 dB ($20 \log [3/2.5]$). Due to the theoretical quantization noise, however, the observed improvement is approximately 1 dB. The AD780 can be selected with a 3 V reference voltage.

Power Supply

The AD7660 uses three sets of power supply pins: an analog 5 V supply AVDD, a digital 5 V core supply DVDD, and a digital input/output interface supply OVDD. The OVDD supply allows direct interface with any logic working between 2.7 V and 5.25 V. To reduce the number of supplies needed, the digital core (DVDD) can be supplied through a simple RC filter from the analog supply, as shown in Figure 5. The AD7660 is independent

of power supply sequencing and thus free from supply voltage induced latch-up. Additionally, it is very insensitive to power supply variations over a wide frequency range, as shown in Figure 9.

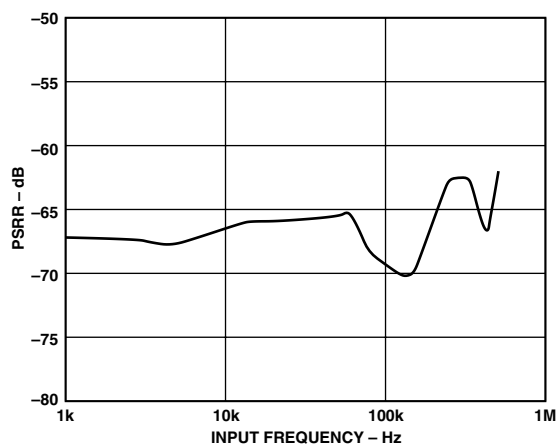

Figure 9. PSRR vs. Frequency

POWER DISSIPATION VS. THROUGHPUT

The AD7660 automatically reduces its power consumption at the end of each conversion phase. During the acquisition phase, the operating currents are very low, which allows a significant power saving when the conversion rate is reduced, as shown in Figure 10. This feature makes the AD7660 ideal for very low power battery applications. It should be noted that the digital interface remains active even during the acquisition phase. To reduce the operating digital supply currents even further, the digital inputs need to be driven close to the power rails (i.e., DVDD and DGND for all inputs except EXT/INT, INVSYN, INVSCLK, RDC/SDIN, and OVDD or OGND for the last four inputs).

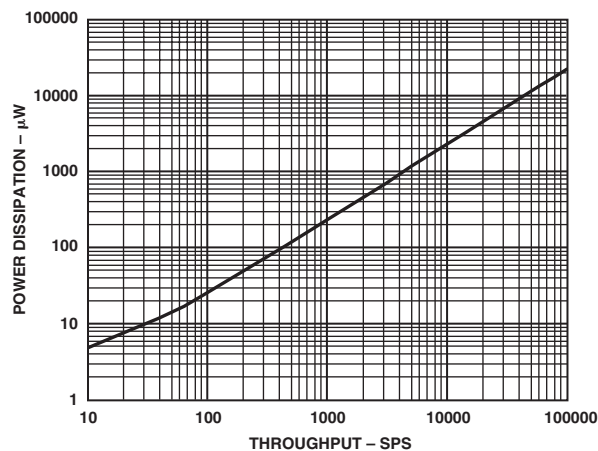

Figure 10. Power Dissipation vs. Sample Rate

AD7660

CONVERSION CONTROL

Figure 11 shows the detailed timing diagrams of the conversion process. The AD7660 is controlled by the signal $\overline{\text{CNVST}}$, which initiates conversion. Once initiated, it cannot be restarted or aborted, even by the power-down input PD, until the conversion is complete. The $\overline{\text{CNVST}}$ signal operates independently of CS and $\overline{\text{RD}}$ signals.

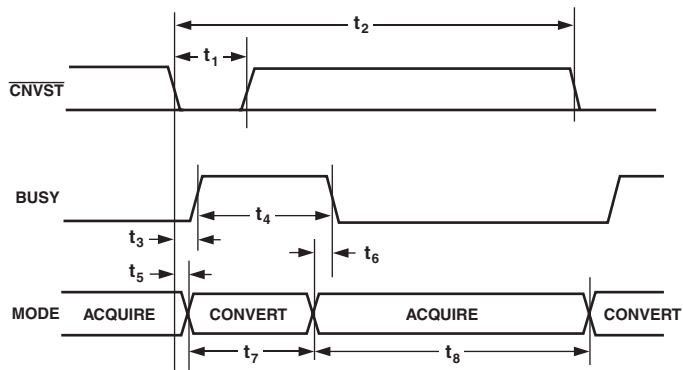

Figure 11. Basic Conversion Timing

For a true sampling application, the recommended operation of the $\overline{\text{CNVST}}$ signal is the following:

$\overline{\text{CNVST}}$ must be held HIGH from the previous falling edge of BUSY, and during a minimum delay corresponding to the acquisition time t_3 ; then, when $\overline{\text{CNVST}}$ is brought LOW, a conversion is initiated and the BUSY signal goes HIGH until the completion of the conversion. Although $\overline{\text{CNVST}}$ is a digital signal, it should be designed with special care with fast, clean edges and levels, with minimum overshoot and undershoot or ringing. For applications where the SNR is critical, the $\overline{\text{CNVST}}$ signal should have a very low jitter. This may be achieved by using a dedicated oscillator for $\overline{\text{CNVST}}$ generation or, at least, to clock it with a high frequency low jitter clock, as shown in Figure 5.

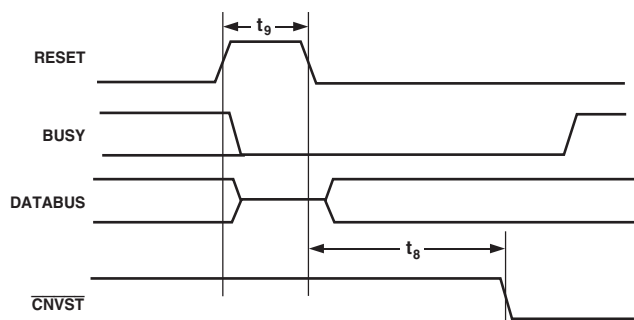

Figure 12. RESET Timing

For other applications, conversions can be automatically initiated. If $\overline{\text{CNVST}}$ is held LOW when BUSY is LOW, the AD7660 controls the acquisition phase and then automatically initiates a new conversion. By keeping $\overline{\text{CNVST}}$ LOW, the AD7660 keeps the conversion process running by itself. It should be noted that the analog input has to be settled when BUSY goes LOW. Also, at power-up, $\overline{\text{CNVST}}$ should be brought LOW once to initiate the conversion process. In this mode, the AD7660 could sometimes run slightly faster than the guaranteed limit of 100 kSPS.

DIGITAL INTERFACE

The AD7660 has a versatile digital interface; it can be interfaced with the host system by using either a serial or parallel interface. The serial interface is multiplexed on the parallel data bus. The AD7660 digital interface also accommodates both 3 V or 5 V logic by simply connecting the OVDD supply pin of the AD7660 to the host system interface digital supply. Finally, by using the $\text{OB}/\overline{2\text{C}}$ input pin, both twos complement or straight binary coding can be used.

The two signals $\overline{\text{CS}}$ and $\overline{\text{RD}}$ control the interface. $\overline{\text{CS}}$ and $\overline{\text{RD}}$ have a similar effect because they are together internally. When at least one of these signals is HIGH, the interface outputs are in high impedance. Usually, $\overline{\text{CS}}$ allows the selection of each AD7660 in multicircuit applications and is held LOW in a single AD7660 design. $\overline{\text{RD}}$ is generally used to enable the conversion result on the data bus.

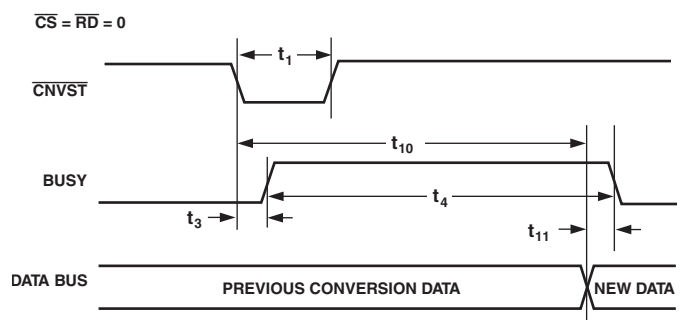

Figure 13. Master Parallel Data Timing for Reading (Continuous Read)

PARALLEL INTERFACE

The AD7660 is configured to use the parallel interface when the $\text{SER}/\overline{\text{PAR}}$ is held LOW. The data can be read either after each conversion, which is during the next acquisition phase, or during the following conversion as shown, respectively, in Figures 14 and 15. When the data is read during the conversion, however, it is recommended that it is read-only during the first half of the conversion phase. This avoids any potential feedthrough between voltage transients on the digital interface and the most critical analog conversion circuitry.

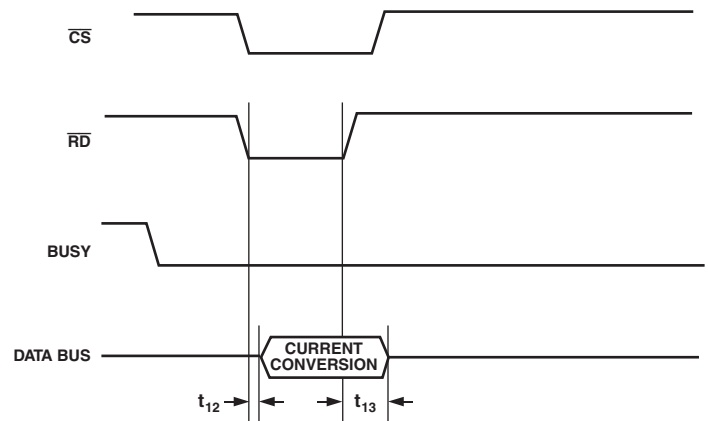

Figure 14. Slave Parallel Data Timing for Reading (Read after Convert)

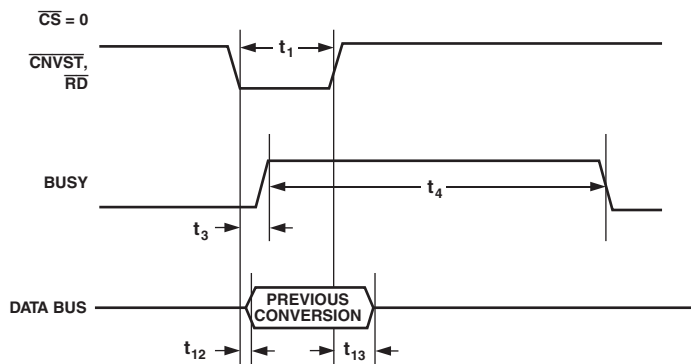

Figure 15. Slave Parallel Data Timing for Reading (Read during Convert)

SERIAL INTERFACE

The AD7660 is configured to use the serial interface when the $\overline{SER}/\overline{PAR}$ is held HIGH. The AD7660 outputs 16 bits of data, MSB first, on the SDOUT pin. This data is synchronized with the 16 clock pulses provided on the SCLK pin.

MASTER SERIAL INTERFACE

Internal Clock

The AD7660 is configured to generate and provide the serial data clock SCLK when the $\overline{EXT}/\overline{INT}$ pin is held LOW. The AD7660 also generates a SYNC signal to indicate to the host when the serial data is valid. The serial clock SCLK and the SYNC signal can be inverted if desired. The output data is valid on both the rising and falling edge of the data clock. Depending on RDC/SDIN input, the data can be read after each conversion or during the following conversion. Figures 16 and 17 show the detailed timing diagrams of these two modes.

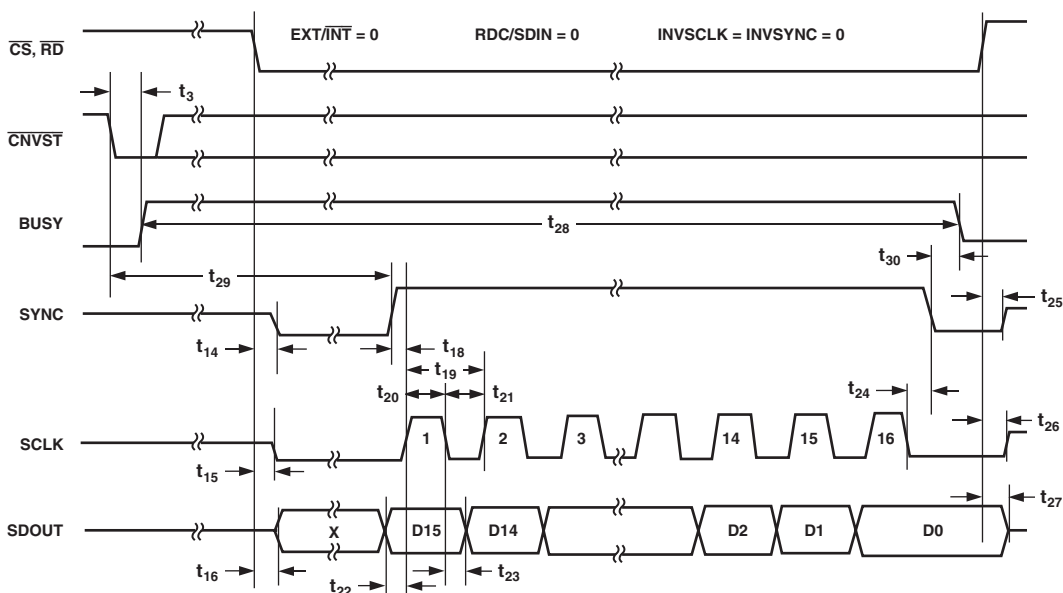

Figure 16. Master Serial Data Timing for Reading (Read after Convert)

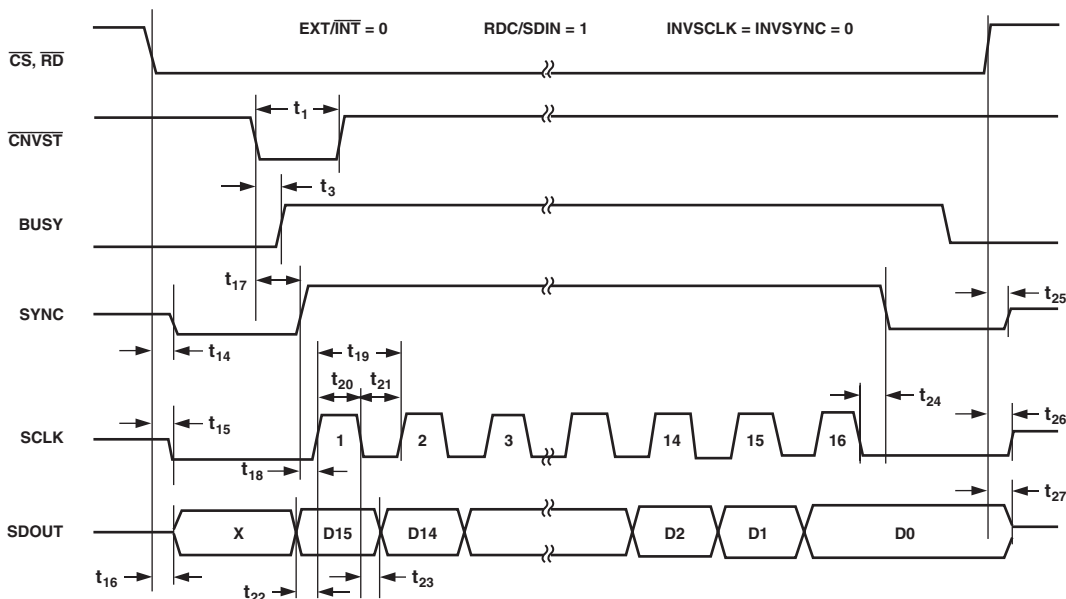

Figure 17. Master Serial Data Timing for Reading (Read Previous Conversion during Convert)

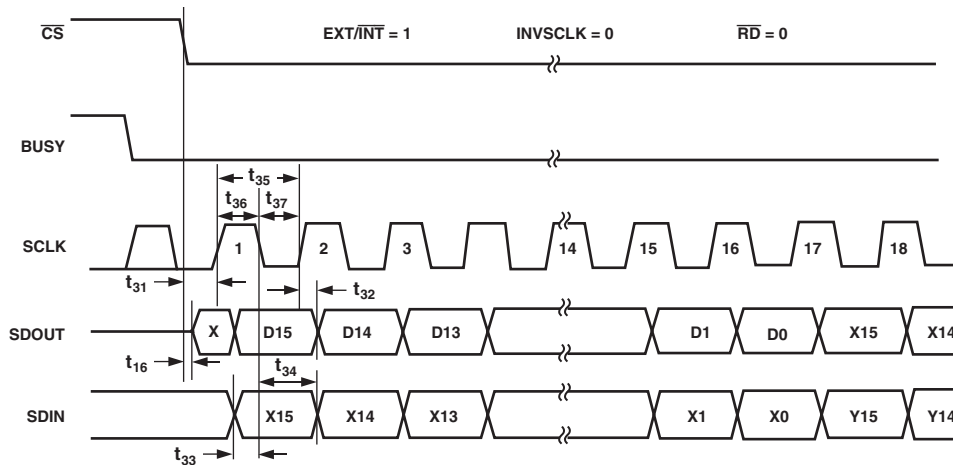

Figure 18. Slave Serial Data Timing for Reading (Read after Convert)

Usually, because the AD7660 has a longer acquisition phase than the conversion phase, the data is read immediately after conversion. This makes the Master Read after conversion the most recommended Serial Mode when it can be used. In this mode, it should be noted that, unlike in other modes, the signal BUSY returns LOW after the 16 data bits are pulsed out and not at the end of the conversion phase, which results in a longer BUSY width.

In Read-during-Conversion Mode, the serial clock and data toggle at appropriate instants, which minimizes potential feedthrough between digital activity and the critical conversion decisions.

SLAVE SERIAL INTERFACE

External Clock

The AD7660 is configured to accept an externally supplied serial data clock on the SCLK pin when the EXT/INT pin is held HIGH. In this mode, several methods can be used to read the data. When \overline{CS} and \overline{RD} are both LOW, the data can be read after each conversion or during the following conversion. The external clock can be either a continuous or discontinuous clock. A discontinuous clock can be either normally HIGH or normally LOW when inactive. Figures 18 and 20 show the detailed timing diagrams of these methods. Usually, because the AD7660 has a longer acquisition phase than the conversion phase, the data are read immediately after conversion.

While the AD7660 is performing a bit decision, it is important that voltage transients not occur on digital input/output pins or degradation of the conversion result could occur. This is particularly important during the second half of the conversion phase because the AD7660 provides error correction circuitry that can correct for an improper bit decision made during the first half of the conversion phase. For this reason, it is recommended that when an external clock is being provided, it is a discontinuous clock that is toggling only when BUSY is LOW or, more importantly, that it does not transition during the latter half of BUSY HIGH.

External Discontinuous Clock Data Read after Conversion

This mode is the most recommended of the serial slave modes. Figure 18 shows the detailed timing diagrams of this method. After a conversion is complete, indicated by BUSY returning LOW,

the result of this conversion can be read while both \overline{CS} and \overline{RD} are LOW. The data is shifted out, MSB first, with 16 clock pulses and is valid on both the rising and falling edge of the clock.

Among the advantages of this method, the conversion performance is not degraded because there are no voltage transients on the digital interface during the conversion process.

Another advantage is the ability to read the data at any speed up to 40 MHz, which accommodates both slow digital host interface and the fastest serial reading.

Finally, in this mode only, the AD7660 provides a “daisy-chain” feature using the RDC/SDIN input pin for cascading multiple converters together. This feature is useful for reducing component count and wiring connections when it is desired as it is, for instance, in isolated multiconverter applications.

An example of the concatenation of two devices is shown in Figure 19. Simultaneous sampling is possible by using a common \overline{CNVST} signal. It should be noted that the RDC/SDIN input is latched on the opposite edge of SCLK of the one used to shift out the data on SDOUT. Therefore, the MSB of the “upstream” converter just follows the LSB of the “downstream” converter on the next SCLK cycle. Up to 20 AD7660s running at 100 kSPS can be daisy-chained using this method.

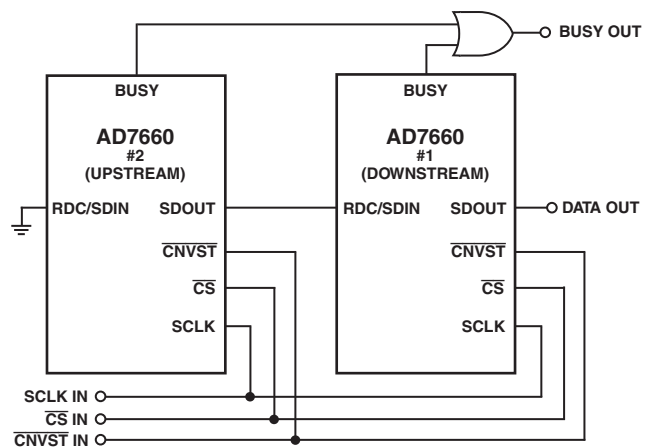

Figure 19. Two AD7660s in a Daisy-Chain Configuration

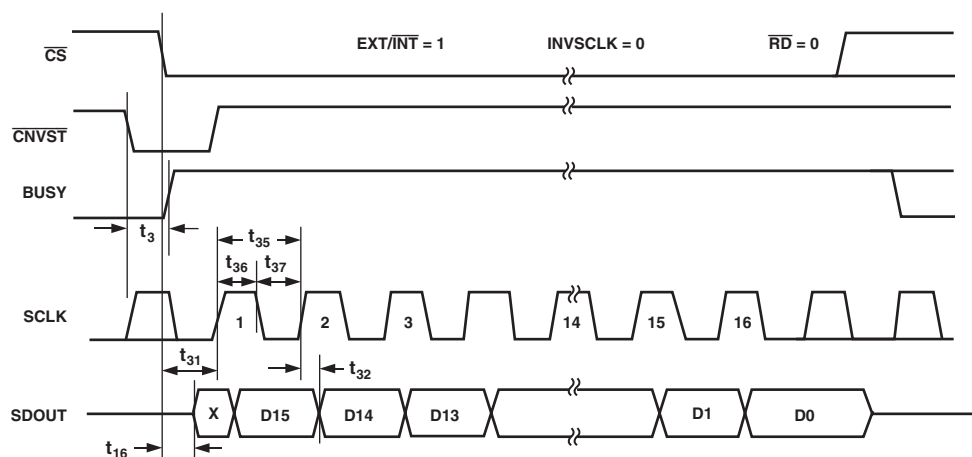

Figure 20. Slave Serial Data Timing for Reading (Read Previous Conversion during Convert)

External Clock Data Read during Conversion

Figure 20 shows the detailed timing diagrams of this method. During a conversion, while both \overline{CS} and \overline{RD} are LOW, the result of the previous conversion can be read. The data is shifted out, MSB first, with 16 clock pulses, and is valid on both the rising and falling edges of the clock. The 16 bits have to be read before the current conversion is complete; this, otherwise, $RDERROR$ is pulsed HIGH and can be used to interrupt the host interface to prevent incomplete data reading. There is no daisy-chain feature in this mode, and $RDC/SDIN$ input should always be tied either HIGH or LOW.

To reduce performance degradation due to digital activity, a fast discontinuous clock of at least 18 MHz is recommended to ensure that all the bits are read during the first half of the conversion phase. For this reason, this mode is more difficult to use.

MICROPROCESSOR INTERFACING

The AD7660 is ideally suited for traditional dc measurement applications supporting a microprocessor, and for ac signal processing applications interfacing to a digital signal processor. The AD7660 is designed to interface either with a parallel 8-bit or 16-bit wide interface, or with a general-purpose serial port or I/O ports on a microcontroller. A variety of external buffers can be used with the AD7660 to prevent digital noise from coupling into the ADC. The following section discusses the use of an AD7660 with an ADSP-219x SPI equipped DSP.

SPI Interface (ADSP-219x)

Figure 21 shows an interface diagram between the AD7660 and an SPI-equipped ADSP-219x. To accommodate the slower speed of the DSP, the AD7660 acts as a slave device and data must be read after conversion. This mode also allows the daisy-chain feature. The convert command can be initiated in response to an internal timer interrupt. The reading process can be initiated in response to the end-of-conversion signal (\overline{BUSY} going LOW) using an interrupt line of the DSP. The serial interface (SPI) on the ADSP-219x is configured for master mode— ($MSTR$) = 1, Clock Polarity bit ($CPOL$) = 0, Clock Phase bit ($CPHA$) = 1, and SPI Interrupt Enable ($TIMOD$) = 00— by writing to the SPI control register ($SPICLTx$). To meet all timing requirements, the SPI clock should be limited to 17 Mbps, which allows it to read an ADC result in less than 1 μ s. When a higher sampling rate is desired, use of one of the parallel interface modes is recommended.

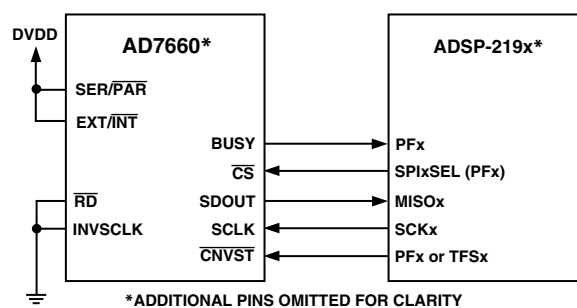

Figure 21. Interfacing the AD7660 to an SPI Interface

AD7660

APPLICATION HINTS

Bipolar and Wider Input Ranges

In some applications, it is desired to use a bipolar or wider analog input range like, for instance, ± 10 V, ± 5 V, or 0 V to 5 V. Although the AD7660 has only one unipolar range, by simple modifications of the input driver circuitry, bipolar and wider input ranges can be used without any performance degradation.

Figure 22 shows a connection diagram that allows this. Component values required and resulting full-scale ranges are shown in Table III.

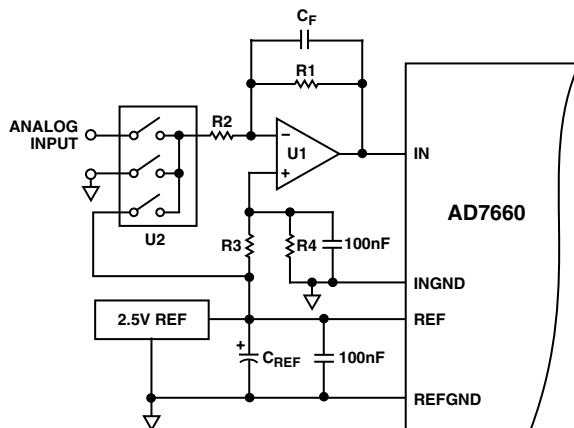

Figure 22. Using the AD7660 in 16-Bit Bipolar and/or Wider Input Ranges

Table III. Component Values and Input Ranges

Input Range	R1 (k Ω)	R2 (k Ω)	R3 (k Ω)	R4 (k Ω)
± 10 V	1	8	10	8
± 5 V	1	4	10	6.67
0 V to -5 V	1	2	None	0

For bipolar range applications where accurate gain and offset are desired, they can be calibrated by acquiring a ground and a voltage reference using an analog multiplexer U2, as shown in Figure 22. Also, C_F can be used as a one-pole antialiasing filter.

Layout

The AD7660 has very good immunity to noise on the power supplies as can be seen in Figure 9. However, care should still be taken with regard to grounding layout.

The printed circuit board that houses the AD7660 should be designed so the analog and digital sections are separated and confined to certain areas of the board. This facilitates the use of ground planes that can be easily separated. Digital and analog ground planes should be joined in only one place, preferably underneath the AD7660, or, at least, as close as possible to the AD7660. If the AD7660 is in a system where multiple devices require analog to digital ground connections, the connection should still be made at one point only, a star ground point that should be established as close as possible to the AD7660.

It is recommended to avoid running digital lines under the device as these will couple noise onto the die. The analog ground plane should be allowed to run under the AD7660 to avoid noise coupling. Fast switching signals like \overline{CNVST} or clocks should be shielded with digital ground to avoid radiating noise to other sections of the board and should never run near analog signal paths. Crossover of digital and analog signals should be avoided. Traces on different but close layers of the board should run at right angles to each other. This will reduce the effect of feedthrough through the board.

The power supply lines to the AD7660 should use as large a trace as possible to provide low impedance paths and reduce the effect of glitches on the power supply lines. Good decoupling is also important to lower the supply's impedance presented to the AD7660 and to reduce the magnitude of the supply spikes. Decoupling ceramic capacitors, typically 100 nF, should be placed on each power supply pins AVDD, DVDD, and OVDD close to, and ideally right up against, these pins and their corresponding ground pins. Additionally, low ESR 10 μ F capacitors should be located in the vicinity of the ADC to further reduce low frequency ripple.

The DVDD supply of the AD7660 can be either a separate supply or come from the analog supply, AVDD, or from the digital interface supply, OVDD. When the system digital supply is noisy, or fast switching digital signals are present, it is recommended if no separate supply is available, to connect the DVDD digital supply to the analog supply AVDD through an RC filter as shown in Figure 6 and to connect the system supply to the interface digital supply OVDD and the remaining digital circuitry. When DVDD is powered from the system supply, it is useful to insert a bead to further reduce high frequency spikes.

The AD7660 has five different ground pins: INGND, REFGND, AGND, DGND, and OGND. INGND is used to sense the analog input signal. REFGND senses the reference voltage and should be a low impedance return to the reference because it carries pulsed currents. AGND is the ground to which most internal ADC analog signals are referenced. This ground must be connected with the least resistance to the analog ground plane. DGND must be tied to the analog or digital ground plane depending on the configuration. OGND is connected to the digital system ground.

OUTLINE DIMENSIONS

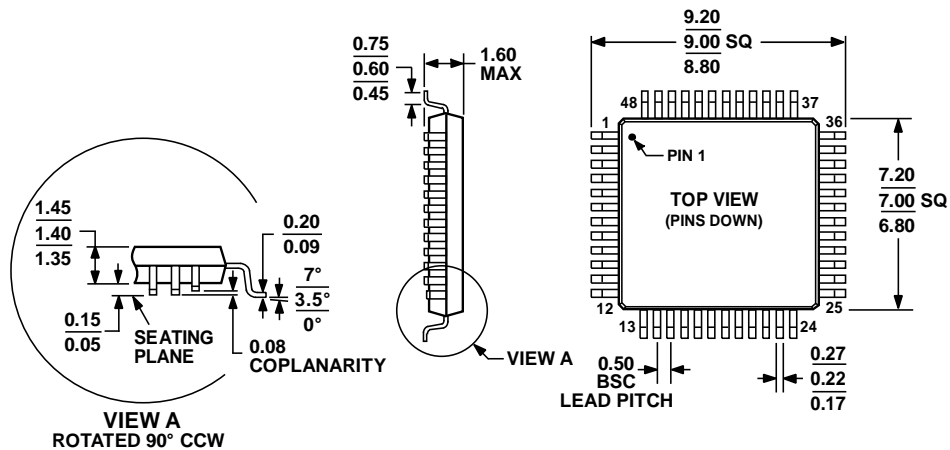

COMPLIANT TO JEDEC STANDARDS MS-026-BBC

Figure 40. 48-Lead Plastic Quad Flat Package [LQFP] (ST-48)

Dimensions shown in millimeters

051706-A

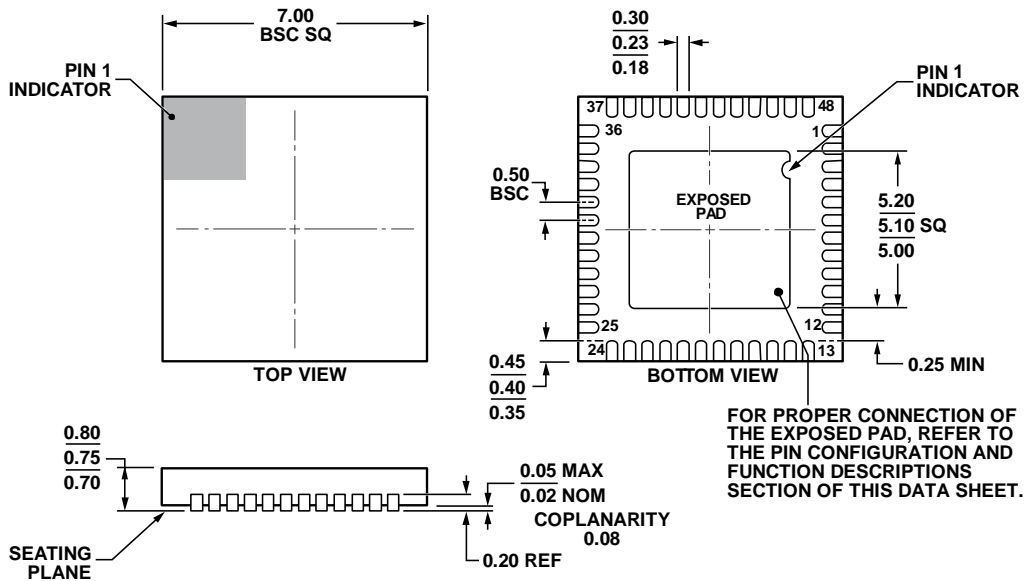

COMPLIANT TO JEDEC STANDARDS MO-220-WKGD.

Figure 41. 48-Lead Lead Frame Chip Scale Package [LFCSF] 7 x 7 mm Body and 0.75 mm Package Height (CP-48-4)

Dimensions shown in millimeters

112408-B

AD7660

Revision History

Location	Page
2/16—Data Sheet changed from REV. D to REV. E.	
Changes to ORDERING GUIDE	4
Changes to PIN CONFIGURATION	4
Changes to PIN FUNCTION DESCRIPTIONS	6
Deleted Evaluating the AD7660 Performance Section	18
Update OUTLINE DIMENSIONS	19
10/03—Data Sheet changed from REV. C to REV. D.	
Update format	Universal
Changes to Table I	1
Added PulSAR Selection table	1
Changes to FEATURES	1
Changes to GENERAL DESCRIPTION	1
Changes to SPECIFICATIONS	2
Changes to ABSOLUTE MAXIMUM RATINGS	4
Changes to ORDERING GUIDE	4
Added Overvoltage Recovery section	7
Added TPC 15	9
Changes to CIRCUIT INFORMATION section	10
Changes to Figure 3	10
Renamed Table I to Table II	11
Changes to Figure 5 Notes	11
Changes to Figure 8 caption	12
Changes to Driver Amplifier Choise section	12
Replaced Figure 10	13
Changes to DIGITAL INTERFACE section	14
Replaced Figure 21	17
Deleted Figure 22 and renumbered successive figures	18
Replaced MICROPROCESSOR INTERFACING section	18
Changes in Bipolar and Wider Input Ranges section	18
Changes to Table III	18
Added CP-48 package	19
Update OUTLINE DIMENSIONS	19
1/02—Data Sheet changed from REV. B to REV. C.	
Edits to FEATURES	1
Edits to FUNCTIONAL BLOCK DIAGRAM	1
Edits to SPECIFICATIONS	2
Edits to PIN FUNCTION DESCRIPTION	6
Edits to Driver Amplifier Choise section	12
New Voltage Reference Input section	13
Edits to DIGITAL INTERFACE section	14
New ST-48 Package Outline	20
9/01—Data Sheet changed from REV. A to REV. B.	
Edit to Specifications	2
Edit to Timing Specifications	3
Edit to ABSOLUTE MAXIMUM RATINGS	4
Edit to ORDERING GUIDE	4
Edit to TYPICAL PERFORMANCE CHARACTERISTICS graphs	9, 10
Edit to DRIVER AMPLIFIER CHOICE section	13
Edit to Figure 18	17
Edit to Figure 20	18
Edit to Table II	19
Edit to Bipolar and Wider Input Ranges section	19

D01928-0-2/16(E)

X-ON Electronics

Largest Supplier of Electrical and Electronic Components

Click to view similar products for [Analog to Digital Converters - ADC category](#):

Click to view products by [Analog Devices manufacturer](#):

Other Similar products are found below :

[ADC0804LCD](#) [ADC0808](#) [MCP37211-200I/TE](#) [MAX15511TGTL+](#) [MCP33141-10T-E/MS](#) [MCP33141D-05T-E/MS](#) [MCP33151D-05T-E/MS](#)
[MCP3202T-CI/MS](#) [MCP33141-05T-E/MS](#) [MCP33141D-10T-E/MS](#) [MCP33151-10T-E/MS](#) [ADE1201ACCZ](#) [ADE1202ACCZ](#) [LTC1090CN](#)
[LTC1605IG](#) [LTC1605AIG](#) [LTC2208IUP](#) [ADS1282HPW](#) [LTC1297DCN8](#) [LTC1741CFW](#) [MCP3422A0-E/MS](#) [MCP3426A2-E/MC](#)
[MCP3427-E/MF](#) [TLC0820ACN](#) [TLC2543IN](#) [TLV2543IDW](#) [NCD9830DBR2G](#) [ADS5231IPAG](#) [ADS7807U](#) [ADS7891IPFBT](#)
[ADS8328IBPW](#) [AMC1204BDWR](#) [ADS7959QDBTRQ1](#) [ADS7807UB](#) [ADS7805UB](#) [ADS1220IPWR](#) [MCP3426A0-E/MS](#) [MCP3423-E/UN](#)
[MCP3422A0-E/MC](#) [AD9220AR](#) [MAX11123ATI+](#) [MAX11212AEUB+](#) [MAX11207EEE+](#) [MAX11135ATI+](#) [TLV1570CDW](#)
[TLC3574IDWR](#) [TLC0838CDWR](#) [AD7714ARZ-5REEL](#) [AD7914BRUZ-REEL7](#) [AD977ABRZ](#)