

### FEATURES

#### Easy to use

- Gain set with 1 external resistor (gain range 1 to 1000)
- Wide power supply operating range:  $\pm 2.3$  V to  $\pm 18$  V
- Temperature range for specified performance:  $-40^{\circ}\text{C}$  to  $+85^{\circ}\text{C}$
- Operational up to  $125^{\circ}\text{C}$ <sup>1</sup>

#### Excellent ac specifications

- 80 dB minimum CMRR to 10 kHz (gain = 1)
- 825 kHz typical, small signal  $-3$  dB bandwidth (gain = 1)
- 2 V/ $\mu\text{s}$  typical slew rate (gain = 1)

#### Low noise

- 8 nV/ $\sqrt{\text{Hz}}$  maximum input voltage noise at 1 kHz
- 0.25  $\mu\text{V}$  p-p typical RTI noise (gain = 100 to 1000)

#### High accuracy dc performance

- 80 dB minimum CMRR dc to 60 Hz with 1 k $\Omega$  source impedance (gain = 1)
- 70  $\mu\text{V}$  maximum input offset voltage
- 0.9  $\mu\text{V}/^{\circ}\text{C}$  maximum input offset voltage, average temperature coefficient
- 1.5 nA maximum input bias current
- Known Good Die (KGD): these die are fully guaranteed to data sheet specifications.

### APPLICATIONS

- Weigh scales
- Industrial process controls
- Bridge amplifiers
- Precision data acquisition systems
- Medical instrumentation
- Strain gages
- Transducer interfaces

### GENERAL DESCRIPTION

The AD8221-KGD is a gain programmable, high performance instrumentation amplifier (in-amp) that delivers high CMRR over frequency. High CMRR over frequency allows the AD8221-KGD to reject wideband interference and line harmonics, greatly simplifying filter requirements. The AD8221-KGD maintains a minimum common-mode rejection ratio (CMRR) of 80 dB to 10 kHz at a gain = 1. Possible applications include precision data acquisition, biomedical analysis, and aerospace instrumentation.

Low voltage offset, low offset drift, low gain drift, high gain accuracy, and high CMRR make this device an excellent choice in applications that demand the best dc performance possible, such as bridge signal conditioning.

Rev. 0

[Document Feedback](#)

Information furnished by Analog Devices is believed to be accurate and reliable. However, no responsibility is assumed by Analog Devices for its use, nor for any infringements of patents or other rights of third parties that may result from its use. Specifications subject to change without notice. No license is granted by implication or otherwise under any patent or patent rights of Analog Devices. Trademarks and registered trademarks are the property of their respective owners.

### CONNECTION DIAGRAM

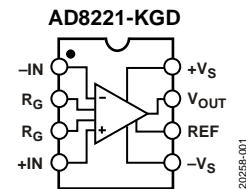

Figure 1.

Programmable gain affords the user design flexibility. A single resistor sets the gain from 1 to 1000. The AD8221-KGD operates on both single and dual supplies and is well suited for applications where  $\pm 10$  V input voltages are encountered.

The AD8221-KGD is available in an 8-pad bare die, making it ideal for multichannel or space-constrained applications.

Performance is specified over the  $-40^{\circ}\text{C}$  to  $+85^{\circ}\text{C}$  industrial temperature range. Furthermore, the AD8221-KGD is operational from  $-40^{\circ}\text{C}$  to  $+125^{\circ}\text{C}$ <sup>1</sup>.

Additional application and technical information can be found in the [AD8221](#) data sheet.

<sup>1</sup> See the [AD8221](#) data sheet for expected operation from  $85^{\circ}\text{C}$  to  $125^{\circ}\text{C}$ .

**TABLE OF CONTENTS**

Features .....	1	ESD Caution.....	6
Applications.....	1	Pin Configuration and Function Descriptions.....	7
General Description .....	1	Outline Dimensions .....	8
Connection Diagram .....	1	Die Specifications and Assembly Recommendations.....	8
Revision History .....	2	Ordering Guide .....	8
Specifications.....	3		
Absolute Maximum Ratings.....	6		

**REVISION HISTORY**

9/2019—Revision 0: Initial Version

## SPECIFICATIONS

Supply voltage ( $V_S$ ) =  $\pm 15$  V, REF voltage ( $V_{REF}$ ) = 0 V,  $T_A$  = 25°C, gain = 1, and load resistance ( $R_L$ ) = 2 k $\Omega$ , unless otherwise noted.

Table 1.

Parameter	Test Conditions/Comments	Min	Typ	Max	Unit
CMRR					
DC to 60 Hz with 1 k $\Omega$ Source Imbalance	Common-mode voltage ( $V_{CM}$ ) = -10 V to +10 V				
Gain = 1		80			dB
Gain = 10		100			dB
Gain = 100		120			dB
Gain = 1000		130			dB
At 10 kHz	$V_{CM} = -10$ V to +10 V				
Gain = 1		80			dB
Gain = 10		90			dB
Gain = 100		100			dB
Gain = 1000		100			dB
NOISE	RTI noise = $\sqrt{e_{NI}^2 + (e_{NO}/Gain)^2}$				
Voltage Noise, 1 kHz					
Input Voltage Noise, $e_{NI}$	+IN voltage ( $V_{+IN}$ ), -IN voltage ( $V_{-IN}$ ), $V_{REF} = 0$ V			8	nV/ $\sqrt{Hz}$
Output Voltage Noise, $e_{NO}$				75	nV/ $\sqrt{Hz}$
Return to Input (RTI)	Frequency = 0.1 Hz to 10 Hz				
Gain = 1			2		$\mu$ V p-p
Gain = 10			0.5		$\mu$ V p-p
Gain = 100 to 1000			0.25		$\mu$ V p-p
Current Noise	Frequency = 1 kHz		40		fA/ $\sqrt{Hz}$
	Frequency = 0.1 Hz to 10 Hz		6		pA p-p
VOLTAGE OFFSET <sup>1</sup>					
Input Offset, $V_{OSI}$	$V_S = \pm 5$ V to $\pm 15$ V			70	$\mu$ V
Over Temperature	$T_A = -40^\circ\text{C}$ to $+85^\circ\text{C}$			135	$\mu$ V
Average Temperature Coefficient				0.9	$\mu$ V/ $^\circ\text{C}$
Output Offset, $V_{OSO}$	$V_S = \pm 5$ V to $\pm 15$ V			600	$\mu$ V
Over Temperature	$T_A = -40^\circ\text{C}$ to $+85^\circ\text{C}$			1.00	mV
Average Temperature Coefficient				9	$\mu$ V/ $^\circ\text{C}$
Offset RTI vs. Supply (Power Supply Ratio)	$V_S = \pm 2.3$ V to $\pm 18$ V				
Gain = 1		90	110		dB
Gain = 10		110	120		dB
Gain = 100		124	130		dB
Gain = 1000		130	140		dB
INPUT CURRENT					
Input Bias Current			0.5	1.5	nA
Over Temperature	$T_A = -40^\circ\text{C}$ to $+85^\circ\text{C}$			2.0	nA
Average Temperature Coefficient			1		pA/ $^\circ\text{C}$
Input Offset Current			0.2	0.6	nA
Over Temperature	$T_A = -40^\circ\text{C}$ to $+85^\circ\text{C}$			0.8	nA
Average Temperature Coefficient			1		pA/ $^\circ\text{C}$

Parameter	Test Conditions/Comments	Min	Typ	Max	Unit
<b>REFERENCE INPUT</b>					
Input Reference ( $R_{IN}$ )			20		k $\Omega$
Input Current ( $I_{IN}$ )	$V_{IN+}, V_{IN-}, V_{REF} = 0V$		50	60	$\mu A$
Voltage Range		$-V_S$		$+V_S$	V
Reference Gain to Output			$1 \pm 0.0001$		V/V
<b>POWER SUPPLY</b>					
Operating Range	$V_S = \pm 2.3V$ to $\pm 18V$	$\pm 2.3$		$\pm 18$	V
Quiescent Current			0.9	1	mA
Over Temperature	$T_A = -40^\circ C$ to $+85^\circ C$		1	1.2	mA
<b>DYNAMIC RESPONSE</b>					
Small Signal -3 dB Bandwidth					
Gain = 1			825		kHz
Gain = 10			562		kHz
Gain = 100			100		kHz
Gain = 1000			14.7		kHz
Settling Time 0.01%					
Gain = 1 to 100	10 V step		10		$\mu s$
Gain = 1000			80		$\mu s$
Settling Time 0.001%					
Gain = 1 to 100	10 V step		13		$\mu s$
Gain = 1000			110		$\mu s$
Slew Rate					
Gain = 1		1.5	2		V/ $\mu s$
Gain = 5 to 100		2	2.5		V/ $\mu s$
<b>GAIN</b>					
Gain Range	Gain = $1 + (49.4 \text{ k}\Omega/R_G)$			1000	V/V
Output voltage ( $V_{OUT}$ ) $\pm 10V$					
Gain Error					
Gain = 1				0.03	%
Gain = 10				0.3	%
Gain = 100				0.3	%
Gain = 1000				0.3	%
Gain Nonlinearity					
Gain = 1 to 10	$V_{OUT} = -10V$ to $+10V$ $R_L = 10 \text{ k}\Omega$		3	10	ppm
Gain = 100	$R_L = 10 \text{ k}\Omega$		5	15	ppm
Gain = 1000	$R_L = 10 \text{ k}\Omega$		10	40	ppm
Gain = 1 to 100	$R_L = 2 \text{ k}\Omega$		10	95	ppm
Gain vs. Temperature					
Gain = 1			3	10	ppm/ $^\circ C$
Gain > $1^2$				-50	ppm/ $^\circ C$
<b>INPUT</b>					
Input Impedance					
Differential			100  2		G $\Omega$ /pF
Common Mode			100  2		G $\Omega$ /pF
Input Operating Voltage Range <sup>3</sup>					
Over Temperature	$V_S = \pm 2.3V$ to $\pm 5V$ $T_A = -40^\circ C$ to $+85^\circ C$	$-V_S + 1.9$ $-V_S + 2.0$		$+V_S - 1.1$ $+V_S - 1.2$	V
Input Operating Voltage Range					
Over Temperature	$V_S = \pm 5V$ to $\pm 18V$ $T_A = -40^\circ C$ to $+85^\circ C$	$-V_S + 1.9$ $-V_S + 2.0$		$+V_S - 1.2$ $+V_S - 1.2$	V

Parameter	Test Conditions/Comments	Min	Typ	Max	Unit
OUTPUT	$R_L = 10\text{ k}\Omega$				
Output Swing	$V_S = \pm 2.3\text{ V to } \pm 5\text{ V}$	$-V_S + 1.1$		$+V_S - 1.2$	V
Over Temperature	$T_A = -40^\circ\text{C to } +85^\circ\text{C}$	$-V_S + 1.4$		$+V_S - 1.3$	V
Output Swing	$V_S = \pm 5\text{ V to } \pm 18\text{ V}$	$-V_S + 1.2$		$+V_S - 1.4$	V
Over Temperature	$T_A = -40^\circ\text{C to } +85^\circ\text{C}$	$-V_S + 1.6$		$+V_S - 1.5$	V
Short-Circuit Current			18		mA
TEMPERATURE RANGE					
Specified Performance		-40		+85	$^\circ\text{C}$
Operating Range <sup>4</sup>		-40		+125	$^\circ\text{C}$

<sup>1</sup> Total RTI  $V_{OS} = (V_{OSI}) + (V_{OSO}/\text{Gain})$ .

<sup>2</sup> Gain > 1 does not include the effects of the external resistor,  $R_G$ .

<sup>3</sup> This is the input operating voltage range when one input is grounded. Gain = 1.

<sup>4</sup> See the [AD8221](#) data sheet for expected operation from  $85^\circ\text{C}$  to  $125^\circ\text{C}$ .

## ABSOLUTE MAXIMUM RATINGS

Table 2.

Parameter	Rating
Supply Voltage	$\pm 18$ V
Internal Power Dissipation	200 mW
Output Short-Circuit Current	Indefinite
Input Voltage (Common-Mode)	$\pm V_s$
Differential Input Voltage	$\pm V_s$
Storage Temperature Range	$-65^{\circ}\text{C}$ to $+150^{\circ}\text{C}$
Operating Temperature Range <sup>1</sup>	$-40^{\circ}\text{C}$ to $+125^{\circ}\text{C}$

<sup>1</sup> See the [AD8221](#) data sheet for expected operation from  $85^{\circ}\text{C}$  to  $125^{\circ}\text{C}$ .

Stresses at or above those listed under Absolute Maximum Ratings may cause permanent damage to the product. This is a stress rating only; functional operation of the product at these or any other conditions above those indicated in the operational section of this specification is not implied. Operation beyond the maximum operating conditions for extended periods may affect product reliability.

### ESD CAUTION



**ESD (electrostatic discharge) sensitive device.** Charged devices and circuit boards can discharge without detection. Although this product features patented or proprietary protection circuitry, damage may occur on devices subjected to high energy ESD. Therefore, proper ESD precautions should be taken to avoid performance degradation or loss of functionality.

## PIN CONFIGURATION AND FUNCTION DESCRIPTIONS

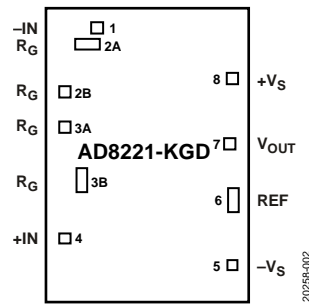

Figure 2. Pad Configuration

Table 3. Pad Function Descriptions

Pad No. <sup>1</sup>	Mnemonic <sup>1</sup>	Pad Type	X Coordinate ( $\mu\text{m}$ ) <sup>2</sup>	Y Coordinate ( $\mu\text{m}$ ) <sup>2</sup>	Description
1	-IN	Single	-379	+951	Negative Input Pad
2A	R <sub>G</sub>	Double	-446	+826	Gain Setting Pad
2B	R <sub>G</sub>	Single	-615	+474	Gain Setting Pad
3A	R <sub>G</sub>	Single	-619	+211	Gain Setting Pad
3B	R <sub>G</sub>	Double	-490	-190	Gain Setting Pad
4	+IN	Single	-621	-622	Positive Input Pad
5	-V <sub>S</sub>	Single	+635	-823	Negative Power Supply Pad
6	REF	Double	+649	-339	Reference Voltage Pad
7	V <sub>OUT</sub>	Single	+612	+84	Output Pad
8	+V <sub>S</sub>	Single	+636	+570	Positive Power Supply Pad

<sup>1</sup> To minimize gain errors introduced by the bond wires, use Kelvin connections between the chip and the gain resistor, R<sub>G</sub>, by connecting Pad 2A and Pad 2B in parallel to one end of R<sub>G</sub> and Pad 3A and Pad 3B in parallel to the other end of R<sub>G</sub>. For unity-gain applications where R<sub>G</sub> is not required, Pad 2A and Pad 2B must be bonded together as well as Pad 3A and Pad 3B.

<sup>2</sup> The pad coordinates indicate the center of each pad, referenced to the center of the die.

OUTLINE DIMENSIONS

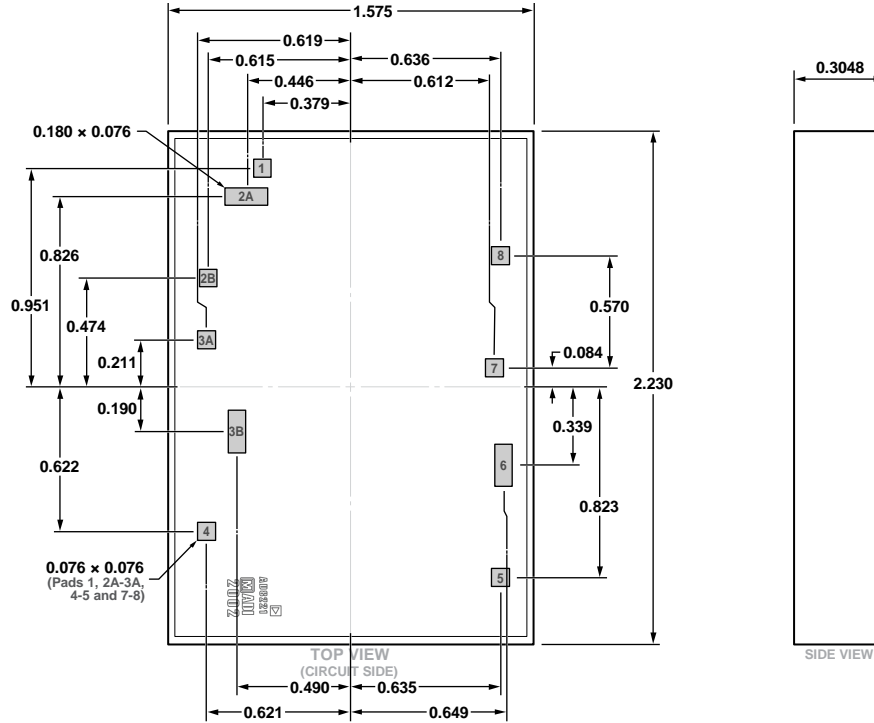

03-11-2019-A

Figure 3. 8-Pad Bare Die [CHIP]  
(C-8-14)  
Dimensions shown in millimeters

DIE SPECIFICATIONS AND ASSEMBLY RECOMMENDATIONS

Table 4. Die Specifications

Parameter	Value	Unit
Chip Size	1500 × 2155	μm
Scribe Line Width	75 × 75	μm
Die Size	1575 × 2230	μm
Thickness	304.8	μm
Backside	None <sup>1</sup>	Not applicable
Passivation	OxyNitride	Not applicable
Bond Pads (Minimum)	76 × 76	μm
Bond Pad Composition	Titanium (Ti), tungsten (W) (99.5)/aluminum (Al), copper (Cu) (0.5)	%

<sup>1</sup> If connecting the backside to a voltage potential, tie the backside to -Vs. Otherwise, leave the backside floating.

Table 5. Assembly Recommendations

Assembly Component	Recommendation
Die Attach	No special requirements
Bonding Method	Gold ball or aluminum wedge
Bonding Sequence	Any

ORDERING GUIDE

Model <sup>1</sup>	Temperature Range	Package Description	Package Option
AD8221-KGD-WP	-40°C to +85°C	8-Pad Bare Die [CHIP], Waffle Pack	C-8-14

<sup>1</sup> The AD8221-KGD-WP is a RoHS compliant part.



## X-ON Electronics

Largest Supplier of Electrical and Electronic Components

*Click to view similar products for [Instrumentation Amplifiers](#) category:*

*Click to view products by [Analog Devices](#) manufacturer:*

Other Similar products are found below :

[ADA4254RU-EBZ](#) [MCP6N16-001E/MF](#) [LT1102IN8#PBF](#) [AD694BRZ-REEL7](#) [LT1101ISW](#) [AD521JDZ](#) [AD521KDZ](#) [AD521LDZ](#)  
[AD524ADZ](#) [AD524BDZ](#) [AD524CDZ](#) [AD620ANZ](#) [AD621BNZ](#) [AD621BR](#) [AD622ANZ](#) [AD623ANZ](#) [AD623BNZ](#) [AD624ADZ](#)  
[AD624CDZ](#) [AD624SD/883B](#) [AD625ADZ](#) [AD625BDZ](#) [AD625JNZ](#) [AD625KNZ](#) [AD625SD](#) [AD627BNZ](#) [AD693AD](#) [AD693AE](#) [AD693AQ](#)  
[AD694AQ](#) [AD694ARZ-REEL](#) [AD694BRZ-REEL](#) [AD694JNZ](#) [AD8221ARMZ-R7](#) [AD8224BCPZ-WP](#) [AD8224HBCPZ-WP](#)  
[AD8226ARMZ-R7](#) [AD8228ARMZ](#) [AD8228ARMZ-R7](#) [AD8229HDZ](#) [AD8236ARMZ-R7](#) [AD8237ARMZ-R7](#) [AD8253ARMZ](#)  
[AD8293G160BRJZ-R7](#) [AD8293G80BRJZ-R2](#) [AD8553ARMZ](#) [AD8553ARMZ-REEL](#) [AD8555ACPZ-REEL7](#) [AD8556ACPZ-R2](#)  
[AD8556ACPZ-REEL7](#)