

FEATURES

Dual-channel

Gain set with 1 resistor per amplifier ($G = 1$ to 10,000)

Low noise

8 nV/ $\sqrt{\text{Hz}}$ e_{NI} at 1 kHz

0.25 μV p-p RTI, $G = 100$ to 1000 (0.1 Hz to 10 Hz)

High accuracy dc performance

120 μV maximum input offset voltage

0.4 $\mu\text{V}/^\circ\text{C}$ maximum average temperature coefficient

2.0 nA maximum input bias current

100 dB minimum CMRR at 4 kHz ($G = 100$ and $G = 1000$)

Excellent ac performance

140 kHz small signal -3 dB bandwidth ($G = 100$)

13 μs settling time to 0.001%

Differential output option (single channel)

Fully specified

Adjustable common-mode output

Power supply operating range: ± 2.3 V to ± 18 V

Operational up to 125°C ¹

Known Good Die (KGD): these die are fully guaranteed to data sheet specifications

APPLICATIONS

Multichannel data acquisition for

Electrocardiogram (ECG) and medical instrumentation

Industrial process controls

Wheatstone bridge sensors

Differential drives for

High resolution input ADCs

Remote sensors

GENERAL DESCRIPTION

The AD8222-KGD is a dual-channel, high performance instrumentation amplifier (in-amp) that requires only one external resistor per amplifier to set gains of 1 to 10,000.

The AD8222-KGD is a dual, in-amp in a small 4 mm \times 4 mm LFCSP. The device requires the same board area as a typical single in-amp. The smaller package allows a 2 \times increase in channel density and a lower cost per channel, all with no compromise in performance.

FUNCTIONAL BLOCK DIAGRAM

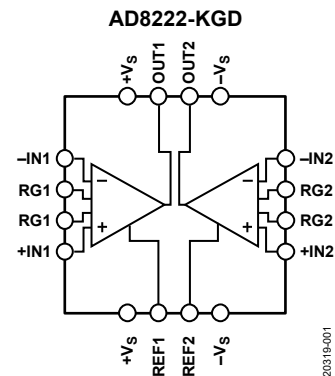

Figure 1.

The AD8222-KGD can also be configured as a single-channel, differential output in-amp. Differential outputs provide high noise immunity, which can be useful when the output signal must travel through a noisy environment, such as with remote sensors. The configuration can also drive differential input analog-to-digital converters (ADCs).

The AD8222-KGD maintains a minimum CMRR of 80 dB to 4 kHz for all grades at $G = 1$. High CMRR over frequency allows the AD8222-KGD to reject wideband interference and line harmonics, greatly simplifying filter requirements. The AD8222-KGD also has a typical CMRR drift over temperature of just 0.07 $\mu\text{V}/\text{V}/^\circ\text{C}$ at $G = 1$.

The AD8222-KGD operates on both single and dual supplies. The device is specified over the industrial temperature range of -40°C to $+85^\circ\text{C}$ and is fully RoHS compliant. Furthermore, the AD8222-KGD is operational from -40°C to $+125^\circ\text{C}$ ¹.

For a single-channel version, see the [AD8221-KGD](#).

Additional application and technical information can be found in the [AD8222](#) data sheet.

¹ See the [AD8222](#) data sheet for expected operation from 85°C to 125°C .

TABLE OF CONTENTS

Features	1	Maximum Power Dissipation	6
Applications.....	1	ESD Caution.....	6
General Description	1	Pin Configuration and Function Descriptions.....	7
Functional Block Diagram	1	Outline Dimensions	8
Revision History	2	Die Specifications and Assembly Recommendations	8
Specifications.....	3	Ordering Guide	8
Absolute Maximum Ratings.....	6		

REVISION HISTORY

1/2020—Rev. 0 to Rev. A	
Changes to Table 4.....	7

10/2019—Revision 0: Initial Version

SPECIFICATIONS

Supply voltage (V_S) = ± 15 V, REFx voltage (V_{REF}) = 0 V, T_A = 25°C, G = 1, and load resistance (R_L) = 2 k Ω , unless otherwise noted.

Table 1. Single-Ended and Differential Output Configuration

Parameter	Test Conditions/Comments	Min	Typ	Max	Unit
COMMON-MODE REJECTION RATIO (CMRR)	Common-mode voltage (V_{CM}) = -10 V to +10 V 1 k Ω source imbalance				
CMRR DC to 60 Hz					
G = 1		80			dB
G = 10		100			dB
G = 100		120			dB
G = 1000		130			dB
CMRR at 4 kHz					
G = 1		80			dB
G = 10		90			dB
G = 100		100			dB
G = 1000		100			dB
CMRR Drift	T_A = -40°C to +85°C, G = 1		0.07		μ V/V/°C
NOISE					
Voltage Noise, 1 kHz	RTI noise = $\sqrt{(e_{NI}^2 + (e_{NO}/G)^2)}$				
Input Voltage Noise, e_{NI}	+IN voltage (V_{+IN}), -IN voltage (V_{-IN}), V_{REF} = 0 V			8	nV/ \sqrt Hz
Output Voltage Noise, e_{NO}	V_{+IN} , V_{-IN} , V_{REF} = 0 V			75	nV/ \sqrt Hz
Return to Input (RTI)	Frequency = 0.1 Hz to 10 Hz				
G = 1			2		μ V p-p
G = 10			0.5		μ V p-p
G = 100 to 1000			0.25		μ V p-p
Current Noise	Frequency = 1 kHz Frequency = 0.1 Hz to 10 Hz		40 6		fA/ \sqrt Hz pA p-p
VOLTAGE OFFSET, V_{OS}	RTI V_{OS} = (V_{OSI}) + (V_{OSO}/G)				
Input Offset, V_{OSI}	V_S = ± 5 V to ± 15 V T_A = -40°C to +85°C			120 150	μ V μ V
Over Temperature				0.4	μ V/°C
Average Temperature Coefficient					
Output Offset, V_{OSO}	V_S = ± 5 V to ± 15 V T_A = -40°C to +85°C			500 0.8	μ V mV
Over Temperature				9	μ V/°C
Average Temperature Coefficient					
Offset RTI vs. Power Supply Ratio (PSR)	V_S = ± 2.3 V to ± 18 V				
G = 1		90	110		dB
G = 10		110	120		dB
G = 100		124	130		dB
G = 1000		130	140		dB
INPUT CURRENT (PER CHANNEL)					
Input Bias Current, I_{BIAS}			0.5	2.0	nA
Over Temperature	T_A = -40°C to +85°C			3.0	nA
Average Temperature Coefficient			1		pA/°C
Input Offset Current, I_{OFFSET}			0.2	1	nA
Over Temperature	T_A = -40°C to +85°C			1.5	nA
Average Temperature Coefficient			1		pA/°C

Parameter	Test Conditions/Comments	Min	Typ	Max	Unit
REFERENCE INPUT					
Input Reference, R_{IN}			20		k Ω
Input Current, I_{IN}	$V_{+IN}, V_{-IN}, V_{REF} = 0\text{ V}$		50	60	μA
Voltage Range		$-V_S$		$+V_S$	V
Reference Gain to Output			1		V/V
Reference Gain Error			0.01		%
GAIN	$G = 1 + (49.4\text{ k}\Omega/R_G)$				
Gain Range		1		10,000	V/V
Gain Error	$V_{OUT} \pm 10\text{ V}$				
$G = 1$				0.3	%
$G = 10$				0.3	%
$G = 100$				0.3	%
$G = 1000$				0.3	%
Gain Nonlinearity	$V_{OUT} = -10\text{ V to }+10\text{ V}$				
$G = 1$			3	10	ppm
$G = 10$			7	20	ppm
$G = 100$			7	20	ppm
Gain vs. Temperature					
$G = 1$			3	10	ppm/ $^{\circ}\text{C}$
$G > 1^1$				-50	ppm/ $^{\circ}\text{C}$
INPUT					
Input Impedance					
Differential			100 2		G Ω pF
Common Mode			100 2		G Ω pF
Input Operating Voltage Range ²	$V_S = \pm 2.3\text{ V to } \pm 5\text{ V}$	$-V_S + 1.9$		$+V_S - 1.1$	V
Over Temperature	$T_A = -40^{\circ}\text{C to }+85^{\circ}\text{C}$	$-V_S + 2.0$		$+V_S - 1.2$	V
Input Operating Voltage Range ²	$V_S = \pm 5\text{ V to } \pm 18\text{ V}$	$-V_S + 1.9$		$+V_S - 1.2$	V
Over Temperature	$T_A = -40^{\circ}\text{C to }+85^{\circ}\text{C}$	$-V_S + 2.0$		$+V_S - 1.2$	V
OUTPUT	$R_L = 10\text{ k}\Omega$				
Output Swing	$V_S = \pm 2.3\text{ V to } \pm 5\text{ V}$	$-V_S + 1.1$		$+V_S - 1.2$	V
Over Temperature	$T_A = -40^{\circ}\text{C to }+85^{\circ}\text{C}$	$-V_S + 1.4$		$+V_S - 1.3$	V
Output Swing	$V_S = \pm 5\text{ V to } \pm 18\text{ V}$	$-V_S + 1.2$		$+V_S - 1.4$	V
Over Temperature	$T_A = -40^{\circ}\text{C to }+85^{\circ}\text{C}$	$-V_S + 1.6$		$+V_S - 1.5$	V
Short-Circuit Current			18		mA
POWER SUPPLY					
Operating Range	$V_S = \pm 2.3\text{ V to } \pm 18\text{ V}$	± 2.3		± 18	V
Quiescent Current (per Amplifier)			0.9	1.1	mA
Over Temperature	$T_A = -40^{\circ}\text{C to }+85^{\circ}\text{C}$		1	1.2	mA
TEMPERATURE RANGE					
Specified Performance		-40		+85	$^{\circ}\text{C}$
Operational ³		-40		+125	$^{\circ}\text{C}$

¹ Does not include the effects of external resistor, R_G .

² One input grounded. $G = 1$.

³ See the AD8222 data sheet for expected operation from 85°C to 125°C .

$V_S = \pm 15\text{ V}$, $V_{REF} = 0\text{ V}$, $T_A = 25^\circ\text{C}$, and $R_L = 2\text{ k}\Omega$, unless otherwise noted.

Table 2. Single-Ended Output Configuration—Dynamic Performance (Both Amplifiers)

Parameter	Test Conditions/Comments	Min	Typ	Max	Unit
DYNAMIC RESPONSE					
Small Signal –3 dB Bandwidth					
G = 1			1200		kHz
G = 10			750		kHz
G = 100			140		kHz
G = 1000			15		kHz
Settling Time to 0.01%	10 V step				
G = 1 to 100			10		μs
G = 1000			80		μs
Settling Time to 0.001%	10 V step				
G = 1 to 100			13		μs
G = 1000			110		μs
Slew Rate	G = 1	1.5	2		$\text{V}/\mu\text{s}$
	G = 5 to 1000	2	2.5		$\text{V}/\mu\text{s}$

ABSOLUTE MAXIMUM RATINGS

Table 3.

Parameter	Rating
V_s	$\pm 18\text{ V}$
Output Short-Circuit Current Duration	Indefinite
Input Voltage (Common Mode)	$\pm V_s$
Differential Input Voltage	$\pm V_s$
Temperature	
Storage Range	-65°C to $+130^\circ\text{C}$
Operational Range ¹	-40°C to $+125^\circ\text{C}$
Package Glass Transition (T_G)	130°C
Electrostatic Discharge (ESD)	
Human Body Model	2 kV
Charge Device Model	1 kV

¹ See the [AD8222](#) data sheet for expected operation from 85°C to 125°C .

Stresses at or above those listed under Absolute Maximum Ratings may cause permanent damage to the product. This is a stress rating only; functional operation of the product at these or any other conditions above those indicated in the operational section of this specification is not implied. Operation beyond the maximum operating conditions for extended periods may affect product reliability.

MAXIMUM POWER DISSIPATION

The maximum safe power dissipation for the AD8222-KGD is limited by the associated rise in junction temperature (T_j) on the die. At approximately 130°C , which is the glass transition temperature, the plastic changes its properties. Even temporarily exceeding this temperature limit may change the stresses that the package exerts on the die, permanently shifting the parametric performance of the amplifiers. Exceeding a temperature of 130°C for an extended period can result in a loss of functionality.

ESD CAUTION



ESD (electrostatic discharge) sensitive device. Charged devices and circuit boards can discharge without detection. Although this product features patented or proprietary protection circuitry, damage may occur on devices subjected to high energy ESD. Therefore, proper ESD precautions should be taken to avoid performance degradation or loss of functionality.

PIN CONFIGURATION AND FUNCTION DESCRIPTIONS

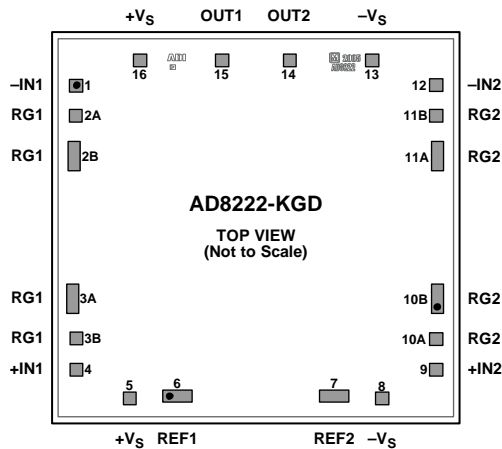

Figure 2. Pad Configuration

Table 4. Pad Function Descriptions

Pad No.	Mnemonic	Pad Type	X-Axis (µm)	Y-Axis (µm)	Description
1	-IN1	Single	-1088	+859	Negative Input In-Amp 1
2A	RG1	Single	-1088	+675	Gain Resistor In-Amp 1
2B	RG1	Double	-1094	+431	Gain Resistor In-Amp 1
3A	RG1	Double	-1096	-429	Gain Resistor In-Amp 1
3B	RG1	Single	-1088	-672	Gain Resistor In-Amp 1
4	+IN1	Single	-1088	-857	Positive Input In-Amp 1
5	+Vs	Single	-763	-1035	Positive Supply
6	REF1	Double	-474	-1018	Reference Adjust In-Amp 1
7	REF2	Double	+472	-1019	Reference Adjust In-Amp 2
8	-Vs	Single	+763	-1035	Negative Supply
9	+IN2	Single	+1088	-857	Positive Input In-Amp 2
10A	RG2	Single	+1088	-672	Gain Resistor In-Amp 2
10B	RG2	Double	+1096	-430.52	Gain Resistor In-Amp 2
11A	RG2	Double	+1094	+431	Gain Resistor In-Amp 2
11B	RG2	Single	+1088	+675	Gain Resistor In-Amp 2
12	-IN2	Single	+1088	+859	Negative Input In-Amp 2
13	-Vs	Single	+702	+1011	Negative Supply
14	OUT2	Single	+204	+1012	Output In-Amp 2
15	OUT1	Single	-204	+1012	Output In-Amp 1
16	+Vs	Single	-702	+1011	Positive Supply

OUTLINE DIMENSIONS

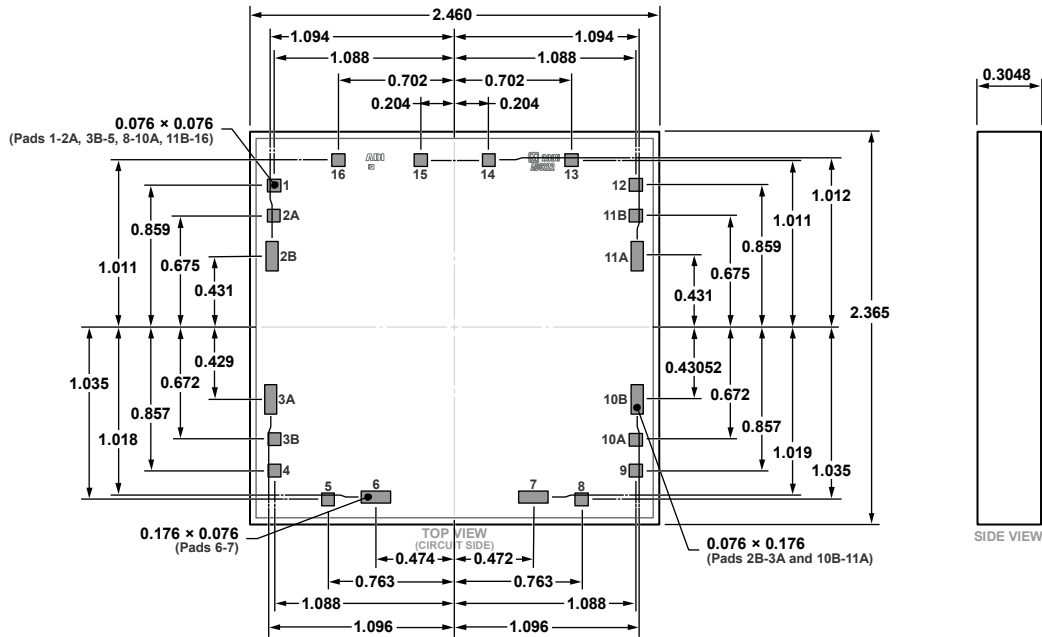

Figure 3. 16-Pad Bare Die [CHIP]
(C-16-3)
Dimensions shown in millimeters

10-09-2019-A

DIE SPECIFICATIONS AND ASSEMBLY RECOMMENDATIONS

Table 5. Die Specifications

Parameter	Value	Unit
Scribe Line Width	75	μm
Die Size (Maximum Size)	2460 × 2365	μm
Thickness	304.8	μm
Bond Pads (Minimum Size)	76 × 76	μm
Bond Pad Composition	Aluminum (Al), copper (Cu), (0.5%)	%
Backside	None ¹	Not applicable
Passivation	Doped oxide/silicon (Si), nitride (N)	Not applicable
ESD, Human Body Model (HBM)	2000	V

¹ If connecting the backside to a voltage potential, tie the backside to the -V_S pin. Otherwise, leave the backside floating.

Table 6. Assembly Recommendations

Assembly Component	Recommendation
Die Attach	Ablestik 8290 conductive
Bonding Method	Gold ball or aluminum wedge
Bonding Sequence	Unspecified

ORDERING GUIDE

Model ¹	Temperature Range	Package Description	Package Option
AD8222-KGD-WP	-40°C to +85°C	16-Pad Bare Die [CHIP], Waffle Pack	C-16-3

¹ The AD8222-KGD-WP is an RoHS compliant part.

X-ON Electronics

Largest Supplier of Electrical and Electronic Components

Click to view similar products for [Instrumentation Amplifiers](#) category:

Click to view products by [Analog Devices](#) manufacturer:

Other Similar products are found below :

[ADA4254RU-EBZ](#) [JM38510/13501BGA](#) [MCP6N16-001E/MF](#) [LT1102IN8#PBF](#) [AD694BRZ-REEL7](#) [LT1101ISW](#) [JM38510/13502BGA](#)
[AD521JDZ](#) [AD521KDZ](#) [AD521LDZ](#) [AD524ADZ](#) [AD524BDZ](#) [AD524CDZ](#) [AD620ANZ](#) [AD621BNZ](#) [AD621BR](#) [AD622ANZ](#) [AD623ANZ](#)
[AD623BNZ](#) [AD624ADZ](#) [AD624CDZ](#) [AD624SD/883B](#) [AD625ADZ](#) [AD625BDZ](#) [AD625JNZ](#) [AD625KNZ](#) [AD625SD](#) [AD627BNZ](#)
[AD693AD](#) [AD693AE](#) [AD693AQ](#) [AD694AQ](#) [AD694ARZ-REEL](#) [AD694BRZ-REEL](#) [AD694JNZ](#) [AD8221ARMZ-R7](#) [AD8222HBCPZ-WP](#)
[AD8224ACPZ-R7](#) [AD8224BCPZ-WP](#) [AD8224HBCPZ-WP](#) [AD8226ARMZ-R7](#) [AD8228ARMZ](#) [AD8228ARMZ-R7](#) [AD8229HDZ](#)
[AD8236ARMZ-R7](#) [AD8237ARMZ-R7](#) [AD8253ARMZ](#) [AD8293G160BRJZ-R7](#) [AD8293G80BRJZ-R2](#) [AD8553ARMZ](#)