

## FEATURES

Complete RF detector function

Typical range:  $-45$  dBm to  $0$  dBm, referencing  $50 \Omega$

Frequency response from  $50$  MHz to  $3.5$  GHz

Temperature stable linear in dB response

Accurate to  $3.5$  GHz

Rapid response:  $85/120$  ns (rise/fall)

Low power:  $12$  mW at  $2.7$  V

## APPLICATIONS

Cellular handsets (GSM, CDMA, WCDMA)

RSSI and TSSI for wireless terminal devices

Transmitter power measurement

## GENERAL DESCRIPTION

The AD8312 is a complete, low cost subsystem for the measurement of radio frequency (RF) signals in the frequency range of  $50$  MHz to  $3.5$  GHz. It has a typical dynamic range of  $45$  dB and is intended for use in a wide variety of cellular handsets and other wireless devices. It provides a wider dynamic range and better accuracy than possible using discrete diode detectors. In particular, its temperature stability is excellent over the full operating range of  $-40^\circ\text{C}$  to  $+85^\circ\text{C}$ . Its high sensitivity allows measurement at low power levels, thus reducing the amount of power that needs to be coupled to the detector. It is essentially a voltage responding device, with a typical signal range of  $1.25$  mV to  $224$  mV rms or  $-45$  dBm to  $0$  dBm, referencing  $50 \Omega$ .

For convenience, the signal is internally ac-coupled, using a  $5$  pF capacitor to a load of  $3$  k $\Omega$  in shunt with  $1.3$  pF. This high-pass coupling, with a corner at approximately  $16$  MHz, determines the lowest operating frequency. Therefore, the source may be dc grounded.

The AD8312 output, VOUT, increases from close to ground to about  $1.2$  V because the input signal level increases from  $1.25$  mV to  $224$  mV. A capacitor may be connected between the VOUT and CFLT pins when it is desirable to increase the time interval over which averaging of the input waveform occurs.

The AD8312 is available in a 6-ball,  $1.0$  mm  $\times$   $1.5$  mm, wafer level chip scale package and consumes  $4.2$  mA from a  $2.7$  V to  $5.5$  V supply.

## FUNCTIONAL BLOCK DIAGRAM

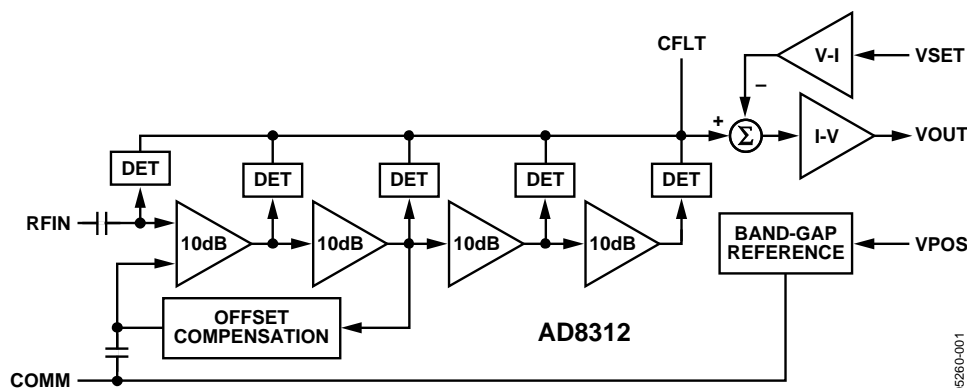

Figure 1.

Rev. B

[Document Feedback](#)

Information furnished by Analog Devices is believed to be accurate and reliable. However, no responsibility is assumed by Analog Devices for its use, nor for any infringements of patents or other rights of third parties that may result from its use. Specifications subject to change without notice. No license is granted by implication or otherwise under any patent or patent rights of Analog Devices. Trademarks and registered trademarks are the property of their respective owners.

One Technology Way, P.O. Box 9106, Norwood, MA 02062-9106, U.S.A.  
 Tel: 781.329.4700 ©2005–2015 Analog Devices, Inc. All rights reserved.  
 Technical Support [www.analog.com](http://www.analog.com)

## TABLE OF CONTENTS

Features .....	1	Transfer Function in Terms of Slope and Intercept.....	13
Applications.....	1	Filter Capacitor .....	14
General Description .....	1	Input Coupling Options .....	14
Functional Block Diagram .....	1	Increasing the Logarithmic Slope .....	15
Revision History .....	2	Effect of Waveform Type on Intercept .....	15
Specifications.....	3	Temperature Drift .....	16
Absolute Maximum Ratings.....	6	Operation Above 2.5 GHz .....	16
ESD Caution.....	6	Device Handling.....	16
Pin Configuration and Function Descriptions.....	7	Evaluation Board.....	16
Typical Performance Characteristics .....	8	Outline Dimensions .....	19
General Description .....	12	Ordering Guide .....	19
Applications.....	13		
Basic Connections .....	13		

## REVISION HISTORY

### 12/15—Rev. A to Rev. B

Change to Figure 30 Caption .....	16
-----------------------------------	----

### 1/11—Rev. 0 to Rev. A

Changes to Figure 29 .....	16
Updated Outline Dimensions .....	19
Changes to Ordering Guide .....	19

### 4/05—Revision 0: Initial Version

## SPECIFICATIONS

$V_S = 3\text{ V}$ , CFLT = open,  $T_A = 25^\circ\text{C}$ , light condition = 600 LUX, 52.3  $\Omega$  termination resistor at RFIN, unless otherwise noted.

Table 1.

Parameter	Test Conditions/Comments	Min	Typ	Max	Unit
<b>SIGNAL INPUT INTERFACE</b>					
	RFIN (Pin 6)				
Specified Frequency Range		0.05		3.5	GHz
Input Voltage Range	Internally ac-coupled	1.25		224	mV rms
Equivalent Power Range	52.3 $\Omega$ external termination	-45		0	dBm
DC Resistance to COMM			100		k $\Omega$
<b>MEASUREMENT MODE</b>					
f = 50 MHz					
Input Impedance			3050    1.4		$\Omega$    pF
$\pm 1$ dB Dynamic Range	$T_A = 25^\circ\text{C}$		50		dB
	$-40^\circ\text{C} < T_A < +85^\circ\text{C}$		42		dB
Maximum Input Level	$\pm 1$ dB error		3		dBm
Minimum Input Level	$\pm 1$ dB error		-47		dBm
Slope			20.25		mV/dB
Intercept			-51.5		dBm
Output Voltage—High Power In	$P_{IN} = -10$ dBm		0.841		V
Output Voltage—Low Power In	$P_{IN} = -40$ dBm		0.232		V
Temperature Sensitivity	$P_{IN} = -10$ dBm				
	$25^\circ\text{C} \leq T_A \leq +85^\circ\text{C}$		0.0010		dB/ $^\circ\text{C}$
	$-40^\circ\text{C} \leq T_A \leq +25^\circ\text{C}$		0.0073		dB/ $^\circ\text{C}$
f = 100 MHz					
Input Impedance			2900    1.3		$\Omega$    pF
$\pm 1$ dB Dynamic Range	$T_A = 25^\circ\text{C}$		48		dB
	$-40^\circ\text{C} < T_A < +85^\circ\text{C}$		40		dB
Maximum Input Level	$\pm 1$ dB error		2		dBm
Minimum Input Level	$\pm 1$ dB error		-46		dBm
Slope		19.0	21.0	23.0	mV/dB
Intercept		-56.0	-50.5	-47.0	dBm
Output Voltage—High Power In	$P_{IN} = -10$ dBm		0.850		V
Output Voltage—Low Power In	$P_{IN} = -40$ dBm		0.222		V
Temperature Sensitivity	$P_{IN} = -10$ dBm				
	$25^\circ\text{C} \leq T_A \leq +85^\circ\text{C}$		0.0002		dB/ $^\circ\text{C}$
	$-40^\circ\text{C} \leq T_A \leq +25^\circ\text{C}$		0.0060		dB/ $^\circ\text{C}$
f = 900 MHz					
Input Impedance			890    1.15		$\Omega$    pF
$\pm 1$ dB Dynamic Range	$T_A = 25^\circ\text{C}$		49		dB
	$-40^\circ\text{C} < T_A < +85^\circ\text{C}$		42		dB
Maximum Input Level	$\pm 1$ dB error		1		dBm
Minimum Input Level	$\pm 1$ dB error		-48.0		dBm
Slope			20.25		mV/dB
Intercept			-51.9		dBm
Output Voltage—High Power In	$P_{IN} = -10$ dBm		0.847		V
Output Voltage—Low Power In	$P_{IN} = -40$ dBm		0.237		V
Temperature Sensitivity	$P_{IN} = -10$ dBm				
	$25^\circ\text{C} \leq T_A \leq 85^\circ\text{C}$		0.0019		dB/ $^\circ\text{C}$
	$-40^\circ\text{C} \leq T_A \leq +25^\circ\text{C}$		0.0010		dB/ $^\circ\text{C}$

Parameter	Test Conditions/Comments	Min	Typ	Max	Unit
f = 1.9 GHz					
Input Impedance			450    1.13		$\Omega$    pF
$\pm 1$ dB Dynamic Range	$T_A = 25^\circ\text{C}$ $-40^\circ\text{C} < T_A < +85^\circ\text{C}$		48		dB
Maximum Input Level	$\pm 1$ dB error		40		dB
Minimum Input Level	$\pm 1$ dB error		1		dBm
Slope			-47		dBm
Intercept			19.47		mV/dB
Output Voltage – High Power In	$P_{IN} = -10$ dBm		-52.4		dBm
Output Voltage – Low Power In	$P_{IN} = -40$ dBm		0.826		V
Temperature Sensitivity	$P_{IN} = -10$ dBm $25^\circ\text{C} \leq T_A \leq 85^\circ\text{C}$ $-40^\circ\text{C} \leq T_A \leq +25^\circ\text{C}$		0.240		V
			0.004		dB/°C
			0.005		dB/°C
f = 2.2 GHz					
Input Impedance			430    1.09		$\Omega$    pF
$\pm 1$ dB Dynamic Range	$T_A = 25^\circ\text{C}$ $-40^\circ\text{C} < T_A < +85^\circ\text{C}$		48		dB
Maximum Input Level	$\pm 1$ dB error		40		dB
Minimum Input Level	$\pm 1$ dB error		1		dBm
Slope			-47		dBm
Intercept			19.1		mV/dB
Output Voltage—High Power In	$P_{IN} = -10$ dBm		-52.1		dBm
Output Voltage—Low Power In	$P_{IN} = -40$ dBm		0.803		V
Temperature Sensitivity	$P_{IN} = -10$ dBm $25^\circ\text{C} \leq T_A \leq 85^\circ\text{C}$ $-40^\circ\text{C} \leq T_A \leq +25^\circ\text{C}$		0.230		V
			-0.0023		dB/°C
			0.0055		dB/°C
f = 2.5 GHz					
Input Impedance			400    1.03		$\Omega$    pF
$\pm 1$ dB Dynamic Range	$T_A = 25^\circ\text{C}$ $-40^\circ\text{C} < T_A < +85^\circ\text{C}$		49		dB
Maximum Input Level	$\pm 1$ dB error		40		dB
Minimum Input Level	$\pm 1$ dB error		1		dBm
Slope			-48		dBm
Intercept			18.6		mV/dB
Output Voltage—High Power In	$P_{IN} = -10$ dBm		-51.2		dBm
Output Voltage—Low Power In	$P_{IN} = -40$ dBm		0.762		V
Temperature Sensitivity	$P_{IN} = -10$ dBm $25^\circ\text{C} \leq T_A \leq 85^\circ\text{C}$ $-40^\circ\text{C} \leq T_A \leq +25^\circ\text{C}$		0.204		V
			0.005		dB/°C
			-0.0126		dB/°C
OUTPUT INTERFACE					
Minimum Output Voltage	VOUT (Pin 2) No signal at RFIN, $R_L \geq 10$ k $\Omega$		0.02	0.2	V
Maximum Output Voltage <sup>1</sup>	$R_L \geq 10$ k $\Omega$	1.8	2.0		V
General Limit	$2.7$ V $\leq V_S \leq 5.5$ V	$V_S - 1.2$	$V_S - 1$		V
Available Output Current	Sourcing/sinking		2/0.1		mA
Residual RF (at 2f)	f = 0.1 GHz (worst condition)		100		$\mu$ V
Output Noise	RF input = 2.2 GHz, -10 dBm, $f_{NOISE} = 100$ kHz, CFLT open		1.4		$\mu$ V/ $\sqrt{\text{Hz}}$
Fall Time	Input level = off to 0 dBm, 90% to 10%		120		ns
Rise Time	Input level = 0 dBm to off, 10% to 90%		85		ns
VSET INTERFACE					
Input Resistance	VSET (Pin 3)		13		k $\Omega$
Bias Current Source	RFIN = -10 dBm; VSET = 1.2 V		75		$\mu$ A

Parameter	Test Conditions/Comments	Min	Typ	Max	Unit
POWER INTERFACE	VPOS (Pin 1)				
Supply Voltage		2.7	3.0	5.5	V
Quiescent Current		2.8	4.2	5.7	mA
vs. Temperature	$-40^{\circ}\text{C} \leq T_A \leq +85^{\circ}\text{C}$		4.3		mA

<sup>1</sup> Increased output is possible when using an attenuator between VOUT and VSET to raise the slope.

## ABSOLUTE MAXIMUM RATINGS

Table 2.

Parameter	Value
Supply Voltage VPOS	5.5 V
VOOUT, VSET	0 V, VPOS
Input Voltage	1.6 V rms
Equivalent Power	17 dBm
Internal Power Dissipation	200 mW
$\theta_{JA}$ (WLCSP)	200°C/W
Maximum Junction Temperature	125°C
Operating Temperature Range	-40°C to +85°C
Storage Temperature Range	-65°C to +150°C

Stresses at or above those listed under Absolute Maximum Ratings may cause permanent damage to the product. This is a stress rating only; functional operation of the product at these or any other conditions above those indicated in the operational section of this specification is not implied. Operation beyond the maximum operating conditions for extended periods may affect product reliability.

### ESD CAUTION



**ESD (electrostatic discharge) sensitive device.** Charged devices and circuit boards can discharge without detection. Although this product features patented or proprietary protection circuitry, damage may occur on devices subjected to high energy ESD. Therefore, proper ESD precautions should be taken to avoid performance degradation or loss of functionality.

## PIN CONFIGURATION AND FUNCTION DESCRIPTIONS

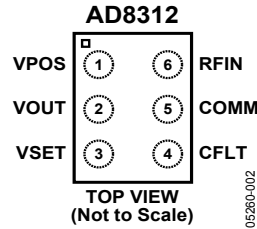

Figure 2. Pin Configuration

Table 3. Pin Function Descriptions

Ball No.	Mnemonic	Description
1	VPOS	Positive Supply Voltage ( $V_s$ ), 2.7 V to 5.5 V.
2	VOUT	Logarithmic Output. Output voltage increases with increasing input amplitude.
3	VSET	Setpoint Input. Connect VSET to VOUT for measurement mode operation. The nominal logarithmic slope of 20 mV/dB can be increased to an arbitrarily high value by attenuating the signal between VOUT and VSET (see the Increasing the Logarithmic Slope section).
4	CFLT	Connection for an External Capacitor to Slow the Response of the Output. Capacitor is connected between CFLT and VOUT.
5	COMM	Device Common (Ground).
6	RFIN	RF Input.

### TYPICAL PERFORMANCE CHARACTERISTICS

$V_S = 3\text{ V}$ ;  $T_A = 25^\circ\text{C}$ ;  $C_{FLT} = \text{open}$ ; light condition = 600 LUX, 52.3  $\Omega$  termination; unless otherwise noted. Colors:  $+25^\circ\text{C} = \text{black}$ ,  $-40^\circ\text{C} = \text{blue}$ ,  $+85^\circ\text{C} = \text{red}$ .

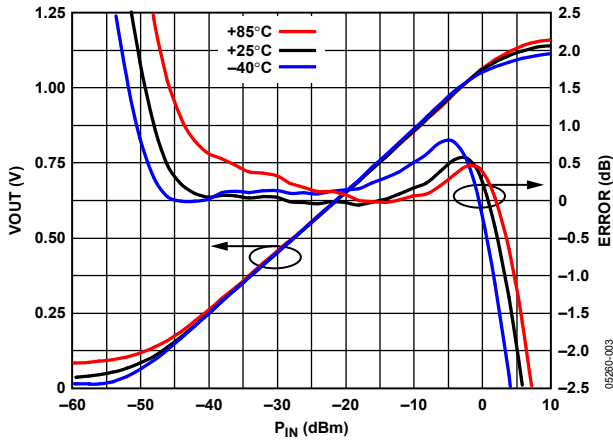

Figure 3. VOUT and Logarithmic Conformance vs. Input Amplitude at 50 MHz; Typical Device at  $-40^\circ\text{C}$ ,  $+25^\circ\text{C}$ , and  $+85^\circ\text{C}$

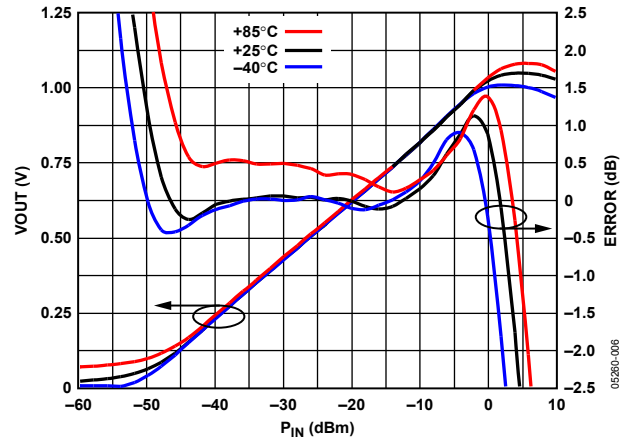

Figure 6. VOUT and Logarithmic Conformance vs. Input Amplitude at 1.9 GHz; Typical Device at  $-40^\circ\text{C}$ ,  $+25^\circ\text{C}$ , and  $+85^\circ\text{C}$

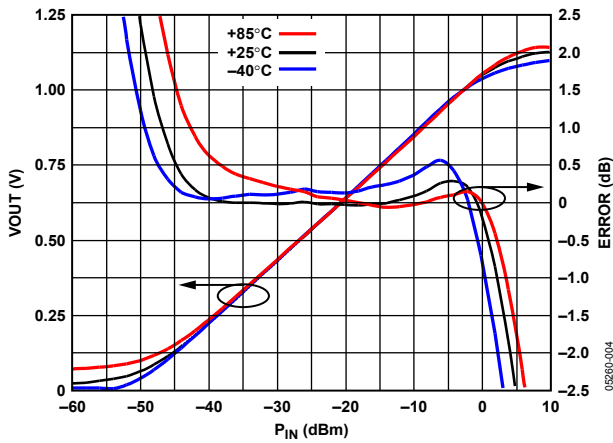

Figure 4. VOUT and Logarithmic Conformance vs. Input Amplitude at 100 MHz; Typical Device at  $-40^\circ\text{C}$ ,  $+25^\circ\text{C}$ , and  $+85^\circ\text{C}$

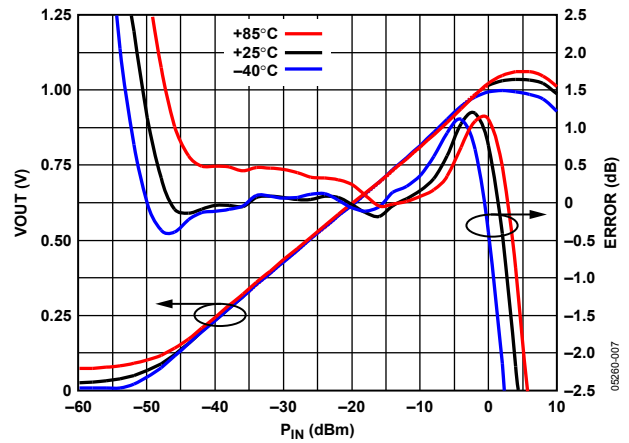

Figure 7. VOUT and Logarithmic Conformance vs. Input Amplitude at 2.2 GHz; Typical Device at  $-40^\circ\text{C}$ ,  $+25^\circ\text{C}$ , and  $+85^\circ\text{C}$

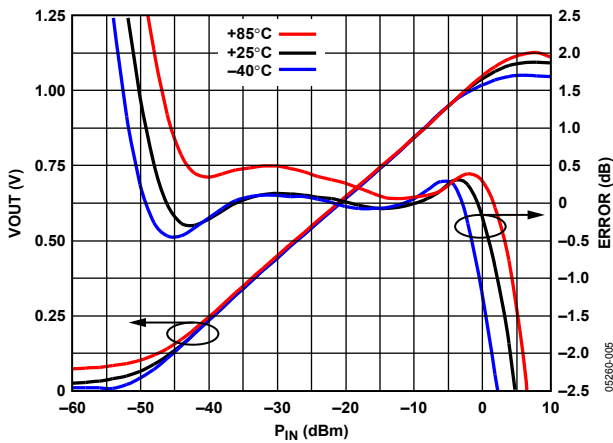

Figure 5. VOUT and Logarithmic Conformance vs. Input Amplitude at 900 MHz; Typical Device at  $-40^\circ\text{C}$ ,  $+25^\circ\text{C}$ , and  $+85^\circ\text{C}$

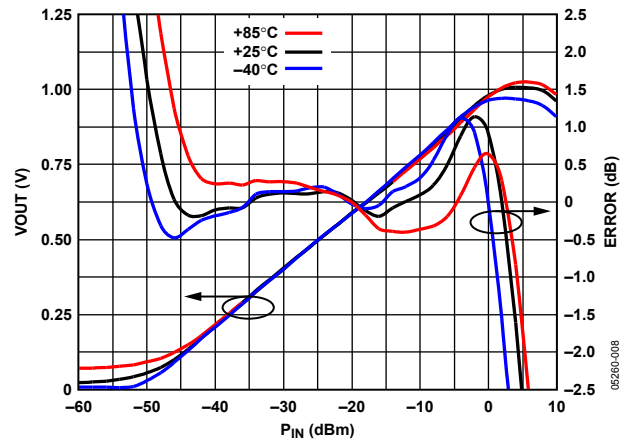

Figure 8. VOUT and Logarithmic Conformance vs. Input Amplitude at 2.5 GHz; Typical Device at  $-40^\circ\text{C}$ ,  $+25^\circ\text{C}$ , and  $+85^\circ\text{C}$



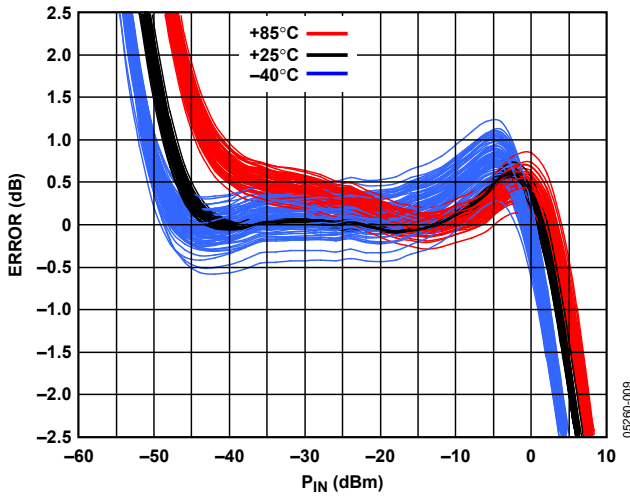

Figure 9. Distribution of Error at  $-40^{\circ}\text{C}$ ,  $+25^{\circ}\text{C}$ , and  $+85^{\circ}\text{C}$  After Ambient Normalization vs. Input Amplitude at 50 MHz for 80 Devices

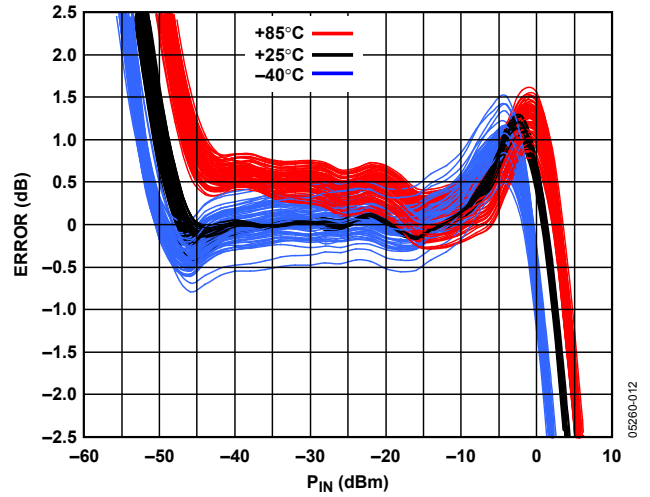

Figure 12. Distribution of Error at  $-40^{\circ}\text{C}$ ,  $+25^{\circ}\text{C}$ , and  $+85^{\circ}\text{C}$  After Ambient Normalization vs. Input Amplitude at 1.9 GHz for 80 Devices

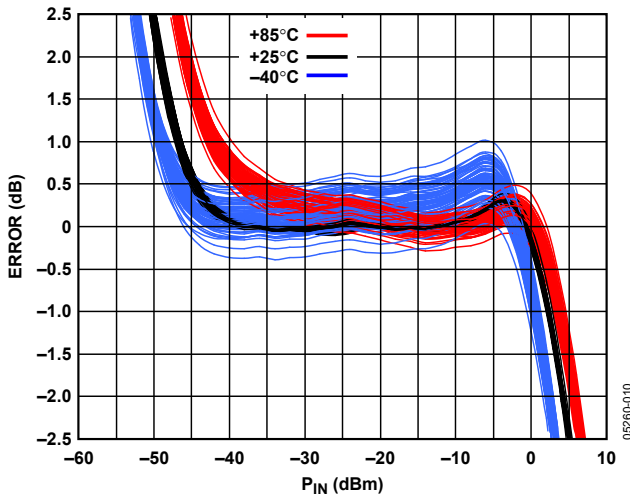

Figure 10. Distribution of Error at  $-40^{\circ}\text{C}$ ,  $+25^{\circ}\text{C}$ , and  $+85^{\circ}\text{C}$  After Ambient Normalization vs. Input Amplitude at 100 MHz for 80 Devices

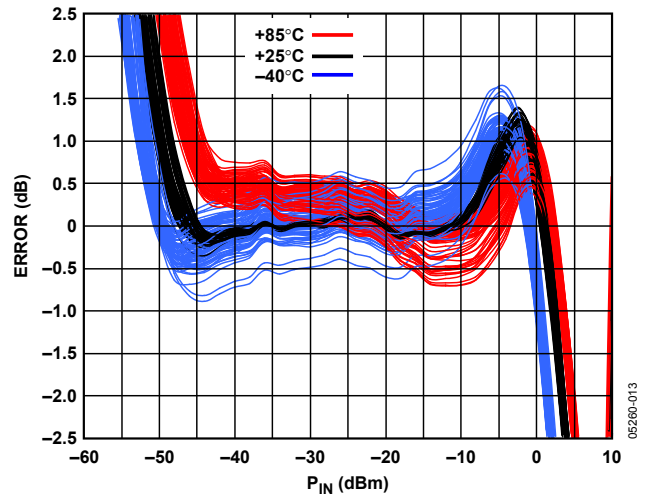

Figure 13. Distribution of Error at  $-40^{\circ}\text{C}$ ,  $+25^{\circ}\text{C}$ , and  $+85^{\circ}\text{C}$  After Ambient Normalization vs. Input Amplitude at 2.2 GHz for 80 Devices

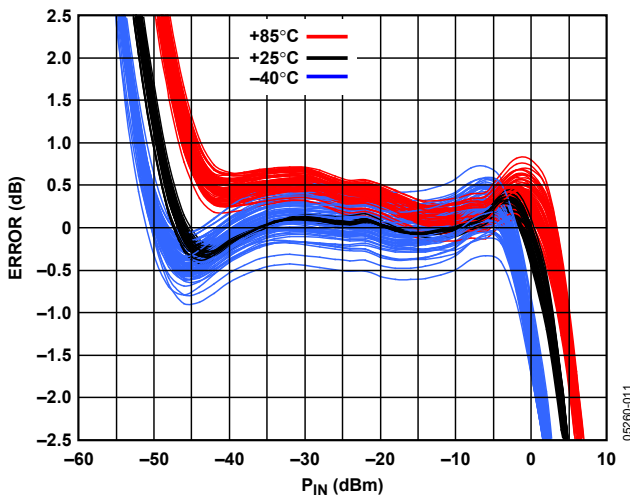

Figure 11. Distribution of Error at  $-40^{\circ}\text{C}$ ,  $+25^{\circ}\text{C}$ , and  $+85^{\circ}\text{C}$  After Ambient Normalization vs. Input Amplitude at 900 MHz for 80 Devices

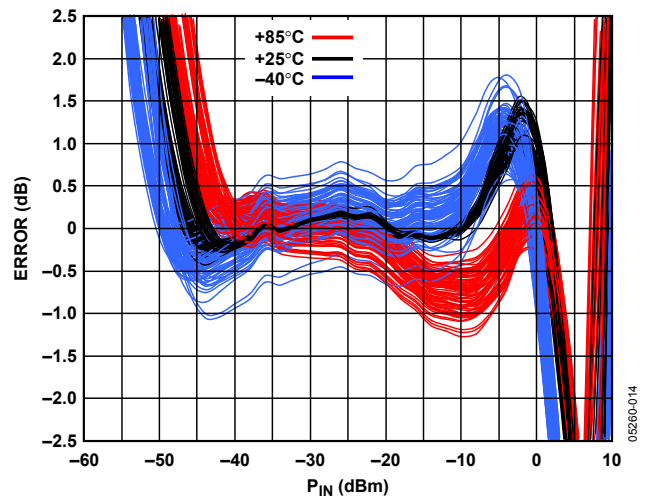

Figure 14. Distribution of Error at  $-40^{\circ}\text{C}$ ,  $+25^{\circ}\text{C}$ , and  $+85^{\circ}\text{C}$  After Ambient Normalization vs. Input Amplitude at 2.5 GHz for 80 Devices

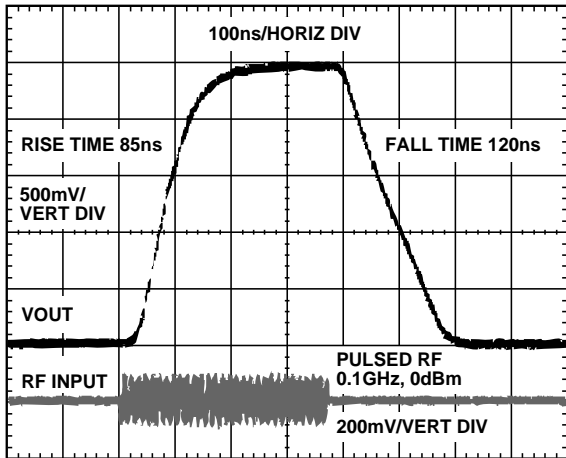

Figure 15. VOUT Response Time, RF Off to 0 dBm

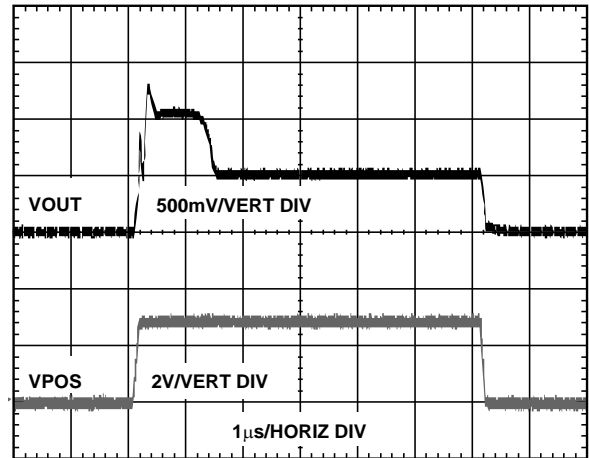

Figure 18. Power-On and Power-Off Response

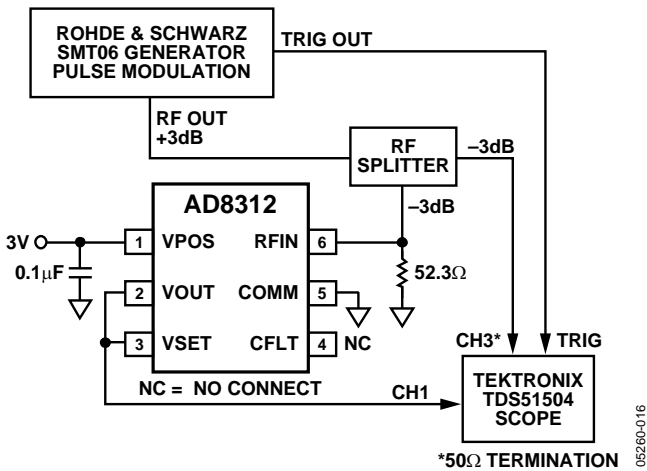

Figure 16. Test Setup for Pulse Response

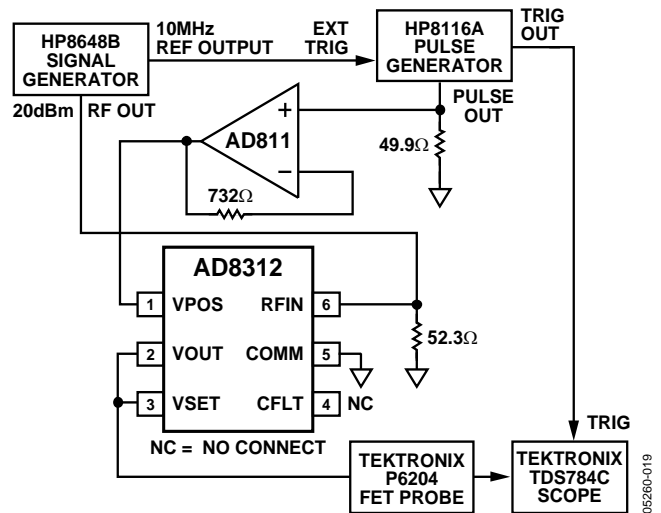

Figure 19. Test Setup for Power-On and Power-Off Response

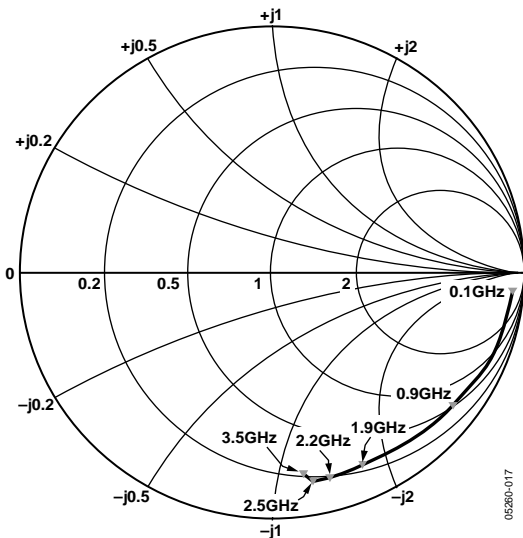

Figure 17. Input Impedance vs. Frequency; No Termination Resistor on RFIN

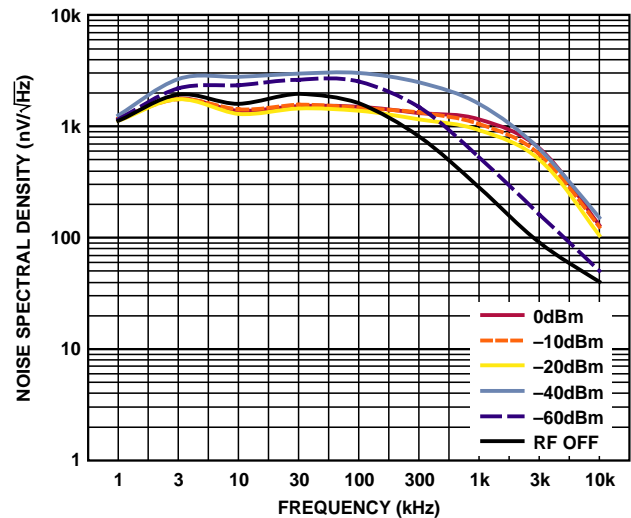

Figure 20. Noise Spectral Density of Output; CFLT = Open

Table 4. Typical Specifications at Selected Frequencies at 25°C (Mean and  $\Sigma$ )

Frequency (GHz)	Slope (mV/dB)		Intercept (dBm)		$\pm 1$ dB Dynamic Range <sup>1</sup> (dBm)			
					High Point		Low Point	
	$\mu$	$\sigma$	$\mu$	$\sigma$	$\mu$	$\sigma$	$\mu$	$\sigma$
0.05	20.25	0.3	-51.5	0.4	+3.0	0.12	-48.0	0.13
0.1	21.0	0.2	-50.5	0.4	+2.0	0.1	-46.0	0.1
0.9	20.25	0.3	-51.9	0.4	+0.2	0.1	-49.0	0.2
1.9	19.47	0.3	-52.4	0.6	+1.5	0.12	-48.8	0.3
2.2	19.1	0.4	-52.1	0.85	+1.5	0.2	-48.5	0.4
2.5	18.6	0.6	-51.2	1.2	+2.0	0.3	-47.7	0.5
3.0	17.5	0.7	-46.9	2.5	-4	0.3	-46	0.4
3.5	17.1	0.7	-42.6	2.5	-1	0.3	-39	0.3

<sup>1</sup> Refer to Figure 23.

## GENERAL DESCRIPTION

The **AD8312** is a logarithmic amplifier similar in design to the **AD8313**; further details about the structure and function may be found in the **AD8313** data sheet and the data sheets of other logarithmic amplifiers produced by Analog Devices, Inc., Figure 21 shows the main features of the **AD8312** in block schematic form.

The **AD8312** combines two key functions needed for the measurement of signal level over a moderately wide dynamic range. First, it provides the amplification needed to respond to small signals in a chain of four amplifier/limiter cells, each having a small signal gain of 10 dB and a bandwidth of approximately 3.5 GHz. At the output of each amplifier stage is a full wave rectifier, essentially a square law detector cell, which converts the RF signal voltages to a fluctuating current with an average value that increases with signal level. A further passive detector stage is added ahead of the first stage. Therefore, there are five detectors, each separated by 10 dB, spanning some 50 dB of dynamic range. The overall accuracy at the extremes of this total range, viewed as the deviation from an ideal logarithmic response, that is, the law conformance error, can be judged by reference to Figure 3 through Figure 8, which show that errors across the central 40 dB are moderate. These figures show how the conformance to an ideal logarithmic function varies with temperature and frequency.

The output of these detector cells is in the form of a differential current, making their summation a simple matter. It can easily be shown that such summation closely approximates a logarithmic function. This result is then converted to a voltage at the **VOUT** pin through a high gain stage.

In measurement modes, this output is connected back to a voltage-to-current (V-to-I) stage, in such a manner that **VOUT** is a logarithmic measure of the RF input voltage with a slope and intercept controlled by the design. For a fixed termination resistance at the input of the **AD8312**, a given voltage corresponds to a certain power level.

The external termination added before the **AD8312** determines the effective power scaling. This often takes the form of a simple resistor (52.3  $\Omega$  provides a net 50  $\Omega$  input), but more elaborate matching networks may be used. This impedance determines the logarithmic intercept, the input power for which the output would cross the baseline ( $V_{OUT} = 0$ ) if the function were continuous for all values of input. Since this is never the case for a practical logarithmic amplifiers, the intercept refers to the value obtained by the minimum error, straight line fit to the actual graph of **VOUT** vs. input power. The quoted values assume a sinusoidal (CW) signal. Where there is complex modulation, as in CDMA, the calibration of the power response needs to be adjusted accordingly. Where a true power (waveform independent) response is needed, the use of an rms responding detector, such as the **AD8361**, should be considered.

However, in terms of the logarithmic slope, the amount by which the output **VOUT** changes for each decibel of input change (voltage or power), is, in principle, independent of waveform or termination impedance. In practice, it usually falls off at higher frequencies because of the declining gain of the amplifier stages and other effects in the detector cells. For the **AD8312**, the slope at low frequencies is nominally 21.0 mV/dB, falling almost linearly with frequency to about 18.6 mV/dB at 2.5 GHz. These values are sensibly independent of temperature and almost totally unaffected by supply voltages of 2.7 V to 5.5 V.

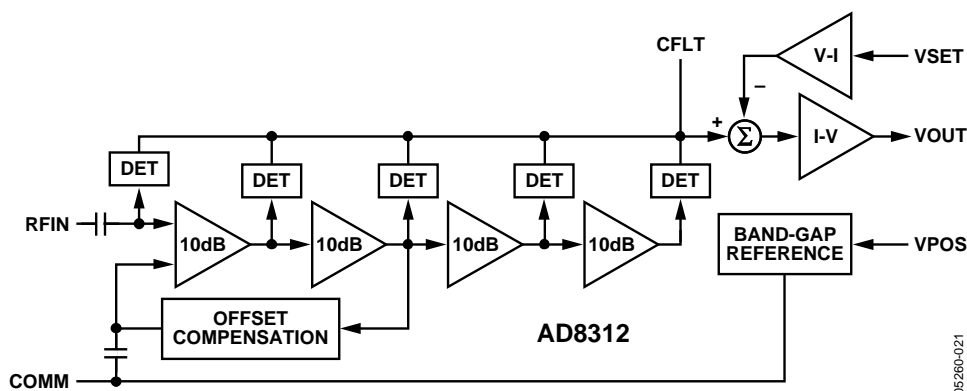

Figure 21. Block Schematic

052860-021

## APPLICATIONS INFORMATION

### BASIC CONNECTIONS

Figure 22 shows the basic connections for measurement mode. A supply voltage of 2.7 V to 5.5 V is required. The supply to the VPOS pin should be decoupled with a low inductance 0.1  $\mu$ F surface-mount ceramic capacitor. A series resistor of about 10  $\Omega$  may be added; this resistor slightly reduces the supply voltage to the AD8312 (maximum current into the VPOS pin is approximately 5.7 mA). Its use should be avoided in applications where the power supply voltage is very low (that is, 2.7 V). A series inductor provides similar power supply filtering with minimal drop in supply voltage.

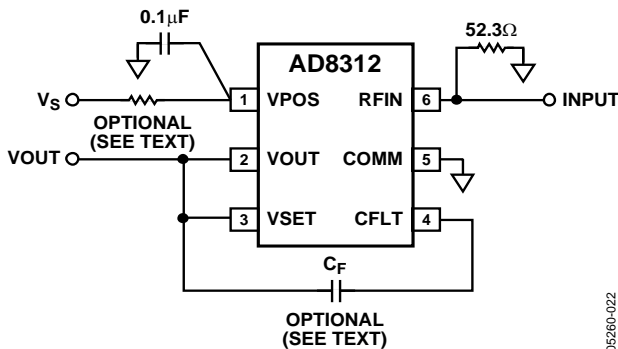

Figure 22. Basic Connections for Operation in Measurement Mode

The AD8312 has an internal input coupling capacitor. This eliminates the need for external ac coupling. In this example, a broadband input match is achieved by connecting a 52.3  $\Omega$  resistor between RFIN and ground. This resistance combines with the internal input impedance of approximately 3 k $\Omega$  to give an overall broadband input resistance of 50  $\Omega$ . Several other coupling methods are possible; these are described in the Input Coupling Options section.

The measurement mode is selected by connecting VSET to VOUT, which establishes a feedback path and sets the logarithmic slope to its nominal value. The peak voltage range of the measurement extends from -49 dBm to 0 dBm at 0.9 GHz and is only slightly less at higher frequencies up to 2.5 GHz. At a slope of 21.0 mV/dB, this would amount to an output span of 1.029 V. Figure 23 shows the transfer function for VOUT at a supply voltage of 2.7 V and an input frequency of 900 MHz.

The load resistance on VOUT should not be lower than 4 k $\Omega$  so that the full-scale output can be generated with the limited available current of 1 mA maximum. Figure 23 shows the logarithmic conformance under the same conditions.

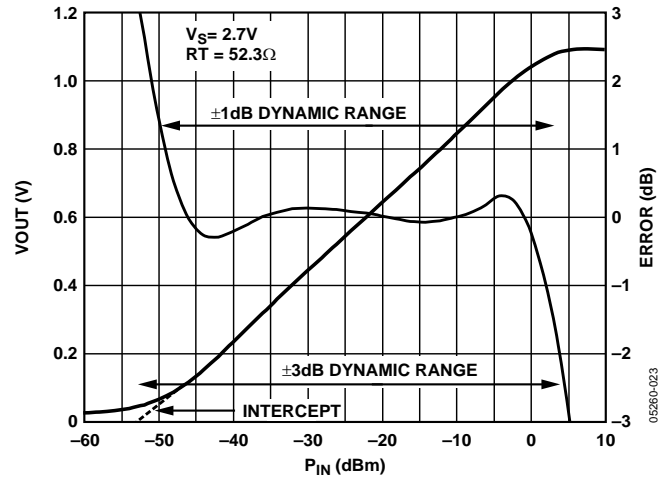

Figure 23. VOUT and Logarithmic Conformance Error vs. Input Level vs. Input Level at 900 MHz

### TRANSFER FUNCTION IN TERMS OF SLOPE AND INTERCEPT

The transfer function of the AD8312 is characterized in terms of its slope and intercept. The logarithmic slope is defined as the change in the RSSI output voltage for a 1 dB change at the input. For the AD8312, the slope is nominally 20 mV/dB. Therefore, a 10 dB change at the input results in a change at the output of approximately 200 mV. Figure 23 shows the range over which the device maintains its constant slope. The dynamic range can be defined as the range over which the error remains within a certain band, usually  $\pm 1$  dB or  $\pm 3$  dB. In Figure 23, for example, the  $\pm 1$  dB dynamic range is approximately 51 dB (from -49 dBm to +2 dBm).

The intercept is the point at which the extrapolated linear response would intersect the horizontal axis (see Figure 23). Using the slope and intercept, the output voltage can be calculated for any input level within the specified input range by

$$V_{OUT} = V_{SLOPE} \times (P_{IN} - P_O)$$

where:

$V_{OUT}$  is the demodulated and filtered RSSI output.

$V_{SLOPE}$  is the logarithmic slope, expressed in V/dB.

$P_{IN}$  is the input signal, expressed in decibels relative to some reference level (dBm in this case).

$P_O$  is the logarithmic intercept, expressed in decibels relative to the same reference level.

For example, at an input level of -27 dBm, the output voltage is

$$V_{OUT} = 0.020 \text{ V/dB} \times [-27 \text{ dBm} - (-50 \text{ dBm})] = 0.46 \text{ V}$$

### Filter Capacitor

The video bandwidth of VOUT is approximately 3.5 MHz. In CW applications where the input frequency is much higher than this, no further filtering of the demodulated signal is required. Where there is a low frequency modulation of the carrier amplitude, however, the low pass corner must be reduced by the addition of an external filter capacitor,  $C_F$  (see Figure 22). The video bandwidth is related to  $C_F$  by

$$\text{Video Bandwidth} = \frac{1}{2\pi \times 13 \text{ k}\Omega \times (3.5 \text{ pF} + C_F)}$$

### Input Coupling Options

The internal 5 pF coupling capacitor of the AD8312, along with the low frequency input impedance of 3 k $\Omega$ , gives a high pass input corner frequency of approximately 16 MHz. This sets the minimum operating frequency. Figure 24 to Figure 26 show three options for input coupling. A broadband resistive match can be implemented by connecting a shunt resistor to ground at RFIN (see Figure 24). This 52.3  $\Omega$  resistor (other values can also be used to select different overall input impedances) combines with the input impedance of the AD8312 (2.9 k $\Omega$  || 1.3 pF) to give a broadband input impedance of 50  $\Omega$ . While the input resistance and capacitance ( $R_{IN}$  and  $C_{IN}$ ) varies by approximately  $\pm 20\%$  from device to device, the dominance of the external shunt resistor means that the variation in the overall input impedance is close to the tolerance of the external resistor.

At frequencies above 2 GHz, the input impedance drops below 450  $\Omega$ ; therefore, it is appropriate to use a larger shunt resistor value. This value is calculated by plotting the input impedance (resistance and capacitance) on a Smith Chart and by choosing the best shunt resistor value to bring the input impedance closest to the center of the chart (see Figure 17). At 2.5 GHz, a shunt resistor of 57.6  $\Omega$  is recommended.

A reactive match can also be implemented as shown in Figure 25. This is not recommended at low frequencies because device tolerances dramatically vary the quality of the match due to the large input resistance. For low frequencies, Figure 24 or Figure 26 is recommended.

In Figure 25, the matching components are drawn as general reactances. Depending on the frequency, the input impedance at that frequency and the availability of standard value components, either a capacitor or an inductor, is used. As in the previous case, the input impedance at a particular frequency is plotted on a Smith Chart and matching components are chosen (Shunt or Series L, or Shunt or Series C) to move the impedance to the center of the chart. Matching components for specific frequencies can be calculated using the Smith Chart (see Figure 17). Table 5 outlines the input impedances for some commonly used frequencies.

The impedance matching characteristics of a reactive matching network provide voltage gain ahead of the AD8312, which increases device sensitivity (see Table 5). The voltage gain is calculated by

$$\text{Voltage Gain}_{\text{dB}} = 20 \log_{10} \sqrt{\frac{R_2}{R_1}}$$

where:

$R_2$  is the input impedance of the AD8312.

$R_1$  is the source impedance to which the AD8312 is being matched.

Note that this gain is only achieved for a perfect match. Component tolerances and the use of standard values tend to reduce gain.

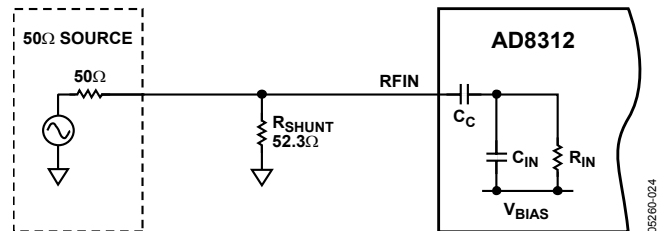

Figure 24. Broadband Resistive Method for Input Coupling

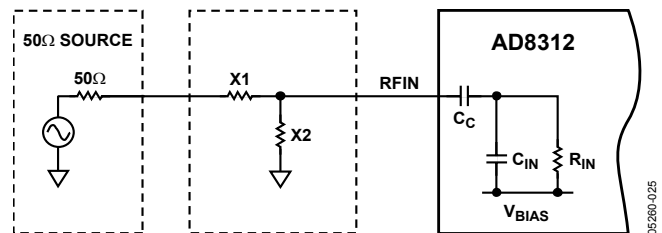

Figure 25. Narrow-Band Reactive Method for Input Coupling

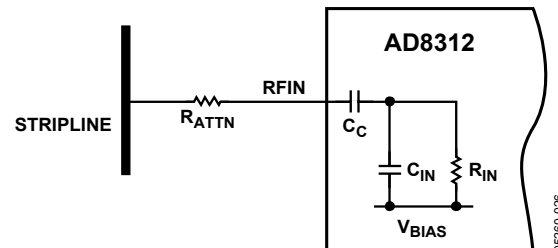

Figure 26. Series Attenuation Method for Input Coupling

Figure 26 shows a third method for coupling the input signal into the AD8312, which is applicable in applications where the input signal is larger than the input range of the logarithmic amplifier. A series resistor, connected to the RF source, combines with the input impedance of the AD8312 to resistively divide the input signal being applied to the input. This has the advantage of very little power being tapped off in RF power transmission applications.

Table 5. Input Impedance for Select Frequency

Frequency (GHz)	S11		Impedance Ω (Series)
	Real	Imaginary	
0.05	0.967	-0.043	1090 - j 1461
0.1	0.962	-0.081	422.6 - j 1015
0.9	0.728	-0.535	25.6 - j 148.5
1.9	0.322	-0.891	11.5 - j 72.69
2.2	0.230	-0.832	9.91 - j 64.74
2.5	0.165	-0.845	9.16 - j 59.91
3.0	0.126	-0.849	8.83 - j 57.21
3.5	0.146	-0.826	10.5 - j 58.54

**Increasing the Logarithmic Slope**

The nominal logarithmic slope of 20 mV/dB can be increased to an arbitrarily high value by attenuating the signal between VOUT and VSET, as shown in Figure 27. The ratio R1/R2 is set by

$$R1/R2 = \left( \frac{\text{New Slope}}{\text{Original Slope}} \right) - 1$$

In the example shown, two 2 kΩ resistors combine to change the slope at 1900 MHz from approximately 20 mV/dB to 40 mV/dB. Note that R2 is in parallel with the input resistance of VSET, typically 13 kΩ. Therefore, the exact R1/R2 ration may vary.

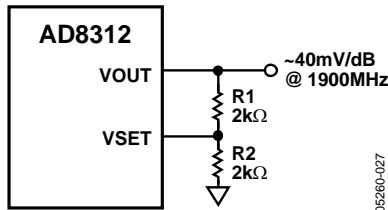

Figure 27. Increasing the Output Slope

The slope can be increased to higher levels, as shown in Figure 28. This, however, reduces the usable dynamic range of the device, depending on the supply voltage.

Output loading should be considered when choosing resistor values for slope adjustment to ensure proper output swing. Note that the load resistance on VOUT should not be lower than 4 kΩ in order that the full-scale output can be generated with the limited available current of 1 mA.

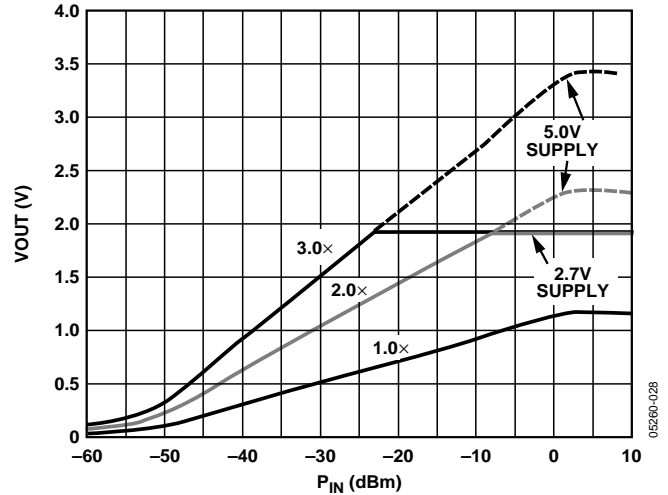

Figure 28. VOUT vs. Input Level at Various Logarithmic Slopes

**Effect of Waveform Type on Intercept**

Although specified for input levels in dBm (dB relative to 1 mW), the AD8312 fundamentally responds to voltage and not to power. A direct consequence of this characteristic is that input signals of equal rms power but differing crest factors, produce different results at the output of the logarithmic amplifier.

The effect of differing signal waveforms is to shift the effective value of the intercept upwards or downwards. Graphically, this looks like a vertical shift in the logarithmic amplifier transfer function. The logarithmic slope, however, is not affected. For example, consider the case of the AD8312 being alternately fed by an unmodulated sine wave and by a 64 QAM signal of the same rms power. The output voltage of the AD8312 differs by the equivalent of 1.6 dB (31 mV) over the complete dynamic range of the device (with the output for a 64 QAM input being lower).

Figure 29 shows the transfer function of the AD8312 when driven by both an unmodulated sine wave and several different signal waveforms. For precision operation, the AD8312 should be calibrated for each signal type that is driving it. To measure the rms power of a 64 QAM input, for example, the mV equivalent of the dB value (19.47 mV/dB × 1.6 dB) should be subtracted from the output voltage of the AD8312.



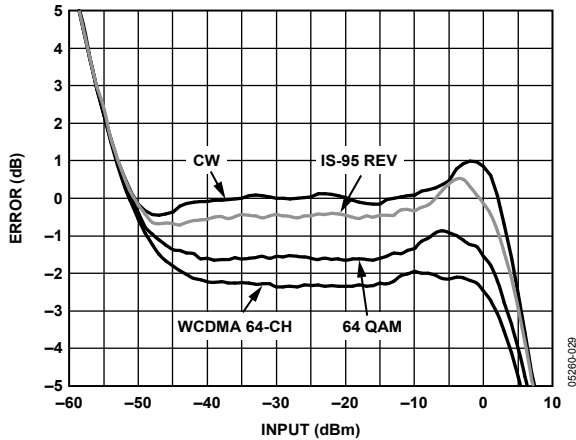

Figure 29. Shift in Transfer Function due to Several Different Signal Waveforms

**Temperature Drift**

Figure 30 shows the logarithmic slope and error over temperature for a 0.9 GHz input signal. Error due to drift over temperature consistently remains within  $\pm 0.5$  dB and only begins to exceed this limit when the ambient temperature goes above  $70^{\circ}\text{C}$ . For all frequencies using a reduced temperature range, higher measurement accuracy is achievable.

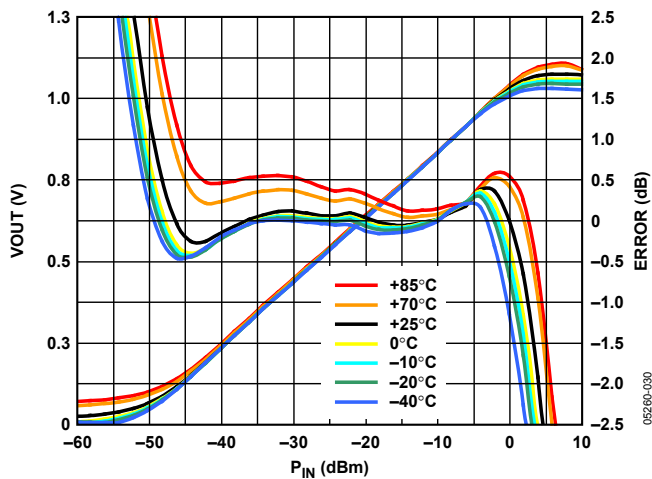

Figure 30. Typical Drift at 900 MHz for Various Temperatures

**Operation Above 2.5 GHz**

The AD8312 works at high frequencies, but exhibits slightly higher output voltage temperature drift. Figure 31 and Figure 32 show the transfer functions and error distributions of a large population of devices at 3.0 GHz and 3.5 GHz over temperature. Due to the repeatability of the drift from device to device, compensation can be applied to reduce the effects of temperature drift. In the case of the 3.5 GHz distribution, an intercept correction of 2.0 dB at  $85^{\circ}\text{C}$  would improve the accuracy of the distribution to  $\pm 2$  dB over a +40 dB range.

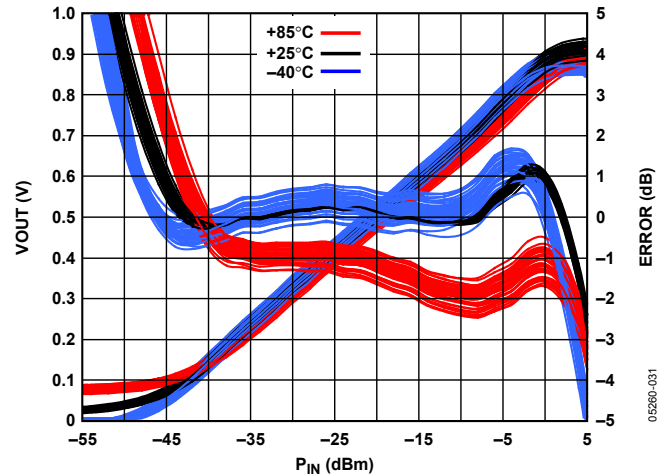

Figure 31. Output Voltage and Error at  $-40^{\circ}\text{C}$ ,  $+25^{\circ}\text{C}$ , and  $+85^{\circ}\text{C}$  after Ambient Normalization vs. Input Amplitude at 3.0 GHz for 60 Devices

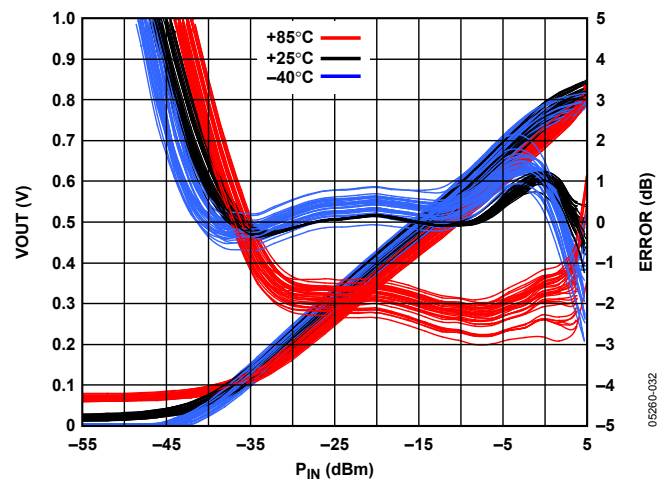

Figure 32. Output Voltage and Error at  $-40^{\circ}\text{C}$ ,  $+25^{\circ}\text{C}$ , and  $+85^{\circ}\text{C}$  after Ambient Normalization vs. Input Amplitude at 3.5 GHz for 30 Devices

**Device Handling**

The wafer level chip scale package consists of solder bumps connected to the active side of the die. The device is lead free with 95.5% tin, 4.0% silver, and 0.5% copper solder bump composition. The WLCSPP package can mount on printed circuit boards using standard surface-mount assembly techniques. However, take caution to avoid damaging the die. See the AN-617 application note, *Wafer Level Chip Scale Package*, for additional information. WLCSPP devices are bumped die; exposed die can be sensitive to light conditions, which can influence specified limits.

**Evaluation Board**

Figure 33 shows the schematic of the AD8312 evaluation board. The layout and silkscreen of the component and circuit sides are shown in Figure 34 to Figure 37. The board is powered by a single supply in the 2.7 V to 5.5 V range. The power supply is decoupled by a single 0.1  $\mu\text{F}$  capacitor. Table 6 details the various configuration options of the evaluation board.



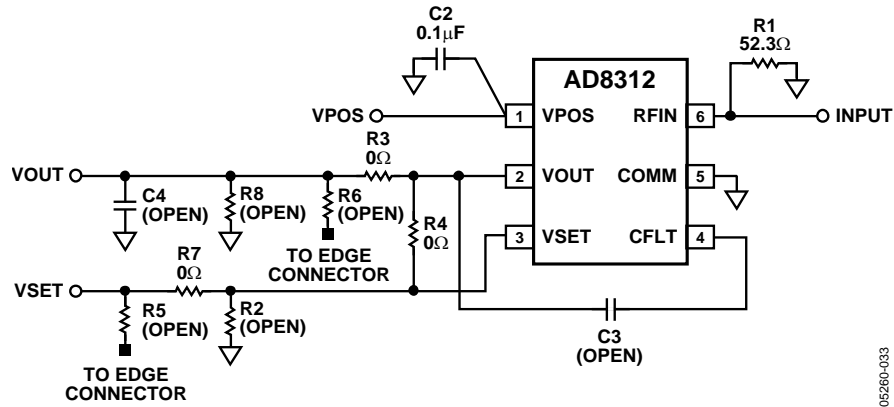

Figure 33. Evaluation Board Schematic

05260-033

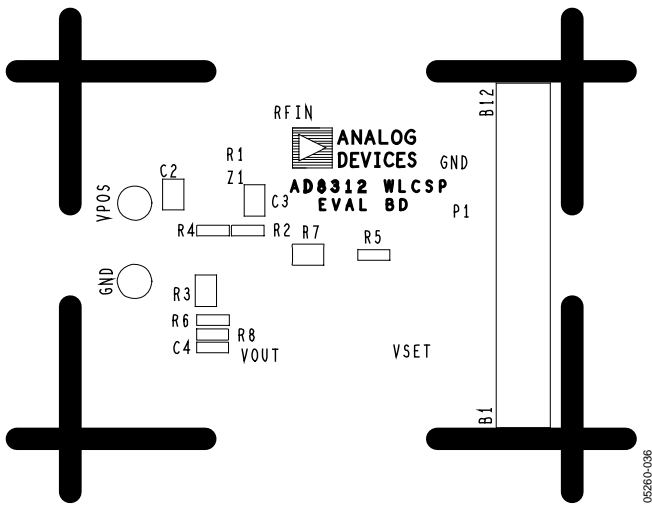

Figure 34. Silkscreen of Component Side (WLCSP)

05260-036

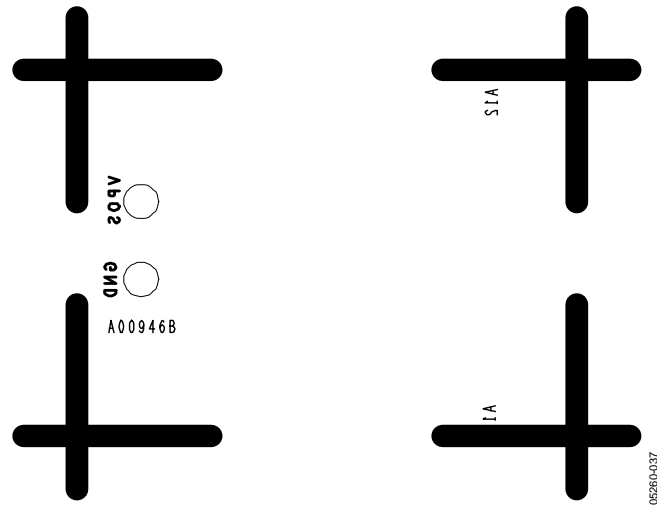

Figure 36. Silkscreen of Circuit Side (WLCSP)

05260-037

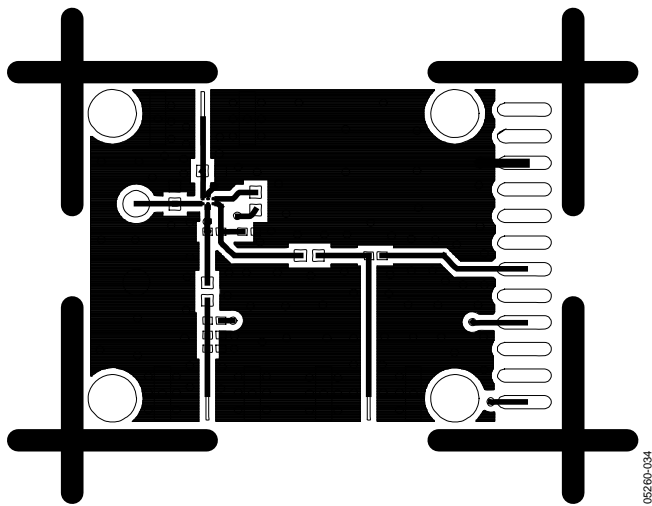

Figure 35. Layout of Component Side (WLCSP)

05260-034

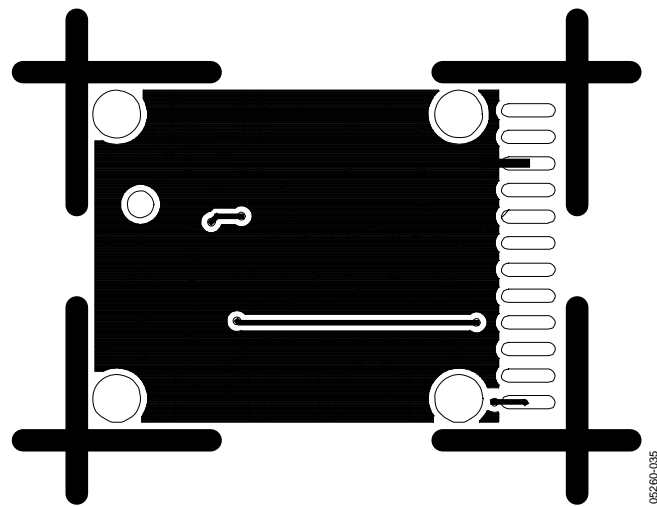

Figure 37. Layout of Circuit Side (WLCSP)

05260-035

Table 6. Evaluation Board Configuration Options

Component	Function	Default Condition
VPOS, GND	Supply and Ground Vector Pins.	Not Applicable
C2	Power Supply Decoupling. The nominal supply decoupling consists of a 0.1 $\mu$ F capacitor (C1).	C2 = 0.1 $\mu$ F (Size 0603)
R1	Input Interface. The 52.3 $\Omega$ resistor in Position R1 combines with the internal input impedance of the <a href="#">AD8312</a> to give a broadband input impedance of around 50 $\Omega$ .	R1 = 52.3 $\Omega$ (Size 0603)
R2, R4	Slope Adjust. By installing resistors in R2 and R4, the nominal slope of 20 mV/dB can be changed. See the Increasing the Logarithmic Slope section for more details.	R2 = Open (Size 0402) R4 = 0 $\Omega$ (Size 0402)
C3	Filter Capacitor. The response time of VOUT can be modified by placing a capacitor between CFLT (Pin 4) and VOUT (Pin 2).	C3 = Open (Size 0603)
R3, R8, C4	Output Interface. R3, R8, and C4 can be used to check the response of VOUT to capacitive and resistive loading. R3/R8 can be used to attenuate VOUT.	R3 = 0 $\Omega$ (Size 0603) R8 = C4 = Open (Size 0402)
R7	VSET Interface. R7 can be used to reduce capacitive loading from transmission lines.	R7 = 0 $\Omega$ (Size 0603)
R5, R6	Alternate Interface. R5 and R6 allow for VOUT and VSET to be accessible from the edge connector, which is only used for characterization.	R5 = R6 = Open (Size 0402)

### OUTLINE DIMENSIONS

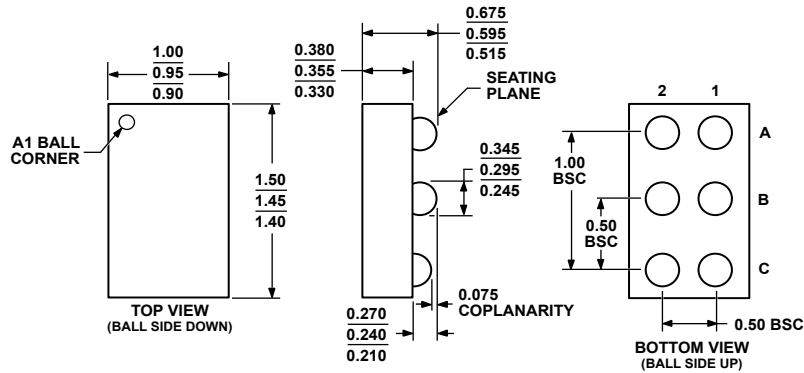

081607-B

Figure 38. 6-Ball Wafer-Level Chip Scale Package [WLCSP] (CB-6-2)

Dimensions shown in millimeters

### ORDERING GUIDE

Model <sup>1</sup>	Temperature Range	Package Description	Package Outline	Branding Information	Ordering Quantity
AD8312ACBZ-P7	-40°C to +85°C	6-Ball WLCSP, 7" Pocket Tape and Reel	CB-6-2	Q00	3000
AD8312ACBZ-P2	-40°C to +85°C	6-Ball WLCSP, 7" Pocket Tape and Reel	CB-6-2	Q00	250
AD8312-EVALZ		Evaluation Board			

<sup>1</sup> Z = RoHS Compliant Part.

**NOTES**

## X-ON Electronics

Largest Supplier of Electrical and Electronic Components

*Click to view similar products for [Amplifier IC Development Tools](#) category:*

*Click to view products by [Analog Devices](#) manufacturer:*

Other Similar products are found below :

[EVAL-ADCMP566BCPZ](#) [EVAL-ADCMP606BKSZ](#) [AD8013AR-14-EBZ](#) [AD8033AKS-EBZ](#) [AD8044AR-EBZ](#) [AD8225-EVALZ](#)  
[ADA4859-3ACP-EBZ](#) [ADA4862-3YR-EBZ](#) [DEM-OPA-SO-2B](#) [AD744JR-EBZ](#) [AD8023AR-EBZ](#) [AD8030ARJ-EBZ](#) [AD8040ARU-EBZ](#)  
[AD8073JR-EBZ](#) [AD813AR-14-EBZ](#) [AD848JR-EBZ](#) [ADA4858-3ACP-EBZ](#) [ADA4922-1ACP-EBZ](#) [551600075-001/NOPB](#) [DEM-OPA-SO-](#)  
[2E](#) [THS7374EVM](#) [EVAL-ADCMP553BRMZ](#) [EVAL-ADCMP608BKSZ](#) [MIOP 42109](#) [EVAL-ADCMP609BRMZ](#) [MAX9928EVKIT+](#)  
[MAX9636EVKIT+](#) [MAX9611EVKIT](#) [MAX9937EVKIT+](#) [MAX9934TEVKIT+](#) [MAX44290EVKIT#](#) [MAX2644EVKIT](#) [MAX4073EVKIT+](#)  
[DEM-OPA-SO-2C](#) [MAX2643EVKIT](#) [ISL28158EVAL1Z](#) [MAX40003EVKIT#](#) [MAX2473EVKIT](#) [MAX2472EVKIT](#) [MAX4223EVKIT](#)  
[MAX9700BEVKIT](#) [MADL-011014-001SMB](#) [DC1685A](#) [DEM-OPA-SO-2D](#) [MAX2670EVKIT#](#) [DEM-OPA-SO-1E](#) [AD8137YCP-EBZ](#)  
[EVAL-ADA4523-1ARMZ](#) [MAX44242EVKIT#](#) [EVAL-LT5401\\_32FDAZ](#)