

FEATURES

- ▶ Up to 2 Mbps isolated bidirectional serial data communications
- ▶ Drop in compatible: single (ADBMS6821) and dual (ADBMS6822)
- ▶ Fully independent dual transceivers (ADBMS6822)
- ▶ Simple galvanic isolation using capacitors or transformers
- ▶ Bidirectional interface over a single twisted pair
- ▶ Supports cable lengths up to 100 meters
- ▶ Very low EMI susceptibility and emissions
- ▶ LPCM support for Analog Devices battery monitors
- ▶ Interrupt output for LPCM system wake-up
- ▶ 4 Mbps unidirectional mode
- ▶ Requires no software changes in most SPI systems
- ▶ Ultralow idle current
- ▶ Automatic interface wake-up detection
- ▶ Operating temperature range: -40°C to $+125^{\circ}\text{C}$
- ▶ 3.0 V to 5.5 V isoSPI driver power supply
- ▶ 1.7 V to 5.5 V interface to microcontrollers
- ▶ 3.0 V to 30 V input for powering wake-up and monitoring functions (12 V battery compatible)
- ▶ 32-lead, side solderable LFCSP
- ▶ AEC-Q100 qualified for automotive applications

APPLICATIONS

- ▶ Electric and hybrid electric vehicles
- ▶ Backup battery systems
- ▶ Industrial networking
- ▶ Remote sensors

FUNCTIONAL BLOCK DIAGRAM

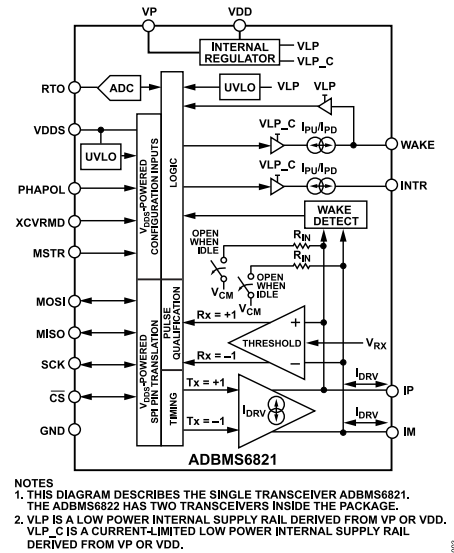

Figure 1.

GENERAL DESCRIPTION

The ADBMS6821¹ (single) and ADBMS6822¹ (dual) provide bidirectional isolated serial port interface (isoSPI™) communications between two isolated devices through a single twisted pair connection for each data link. Each transceiver encodes logic states into signals that are transmitted across an isolation barrier to another transceiver. The receiving device decodes the transmission and drives the slave bus to the appropriate logic states. The isolation barrier can be bridged by capacitors or by a pulse transformer to achieve hundreds of volts of isolation.

The ADBMS6821/ADBMS6822 transceivers drive differential signals using matched source and sink currents, eliminating the requirement for a transformer center tap and reducing electromagnetic interference (EMI). Precision window comparators in the receiver detect the differential signals.

The transceivers can be paired with advanced Analog Devices, Inc., battery stack monitors to enable cell voltage and sensor monitoring even while the system controller is powered down (low power cell monitoring, or LPCM). The transceivers provide a timeout function that wake up or alert the system when a pass heartbeat message has not been received in the programmed time period.

Throughout this data sheet, all pin names refer to both transceivers on the ADBMS6822. For example, VDD refers to both VDD and VDD2.

For more information on the ADBMS6821 or ADBMS6822, visit the [ADBMS6821](#) or [ADBMS6822](#) product page.

¹ Protected by U.S. patents, including 8,908,779.

NOTES

X-ON Electronics

Largest Supplier of Electrical and Electronic Components

Click to view similar products for [RF Transceiver category](#):

Click to view products by [Analog Devices manufacturer](#):

Other Similar products are found below :

[BCM43217KMLG](#) [TRF6900PT](#) [NCH-RSL15-284-101Q40-ACG](#) [NCH-RSL15-512-101Q40-ACG](#) [CA-IF4220NF](#) [RTL8231-GR](#)
[RTL8812BU-CG](#) [AWR2243ABGABLRQ1](#) [AD9364BBCZREEL](#) [ADRV9025ABBCZ](#) [E70-400M14S1B](#) [CST92P12-SSOP24](#) [DL-PAN3031-](#)
[S-433](#) [BGT60LTR11AIP6327XUMA2](#) [SYN470R](#) [Si3933](#) [NRF52810-CAAA-R](#) [AXM0F343-256-1-TX40](#) [AXM0F343-64-1-TX40](#)
[PAN3020BL](#) [PAN3020BV](#) [RTL8188GU-VF0-CG](#) [RTL8370MBI-CG](#) [RTL8188FTV-VQ1-CG](#) [RTL8211FD-VX-CG](#) [RTL8723DS-CG](#)
[RTL8189ETV-CG](#) [RTL8376-GR](#) [RTL8822BU-CG](#) [CC8531RHAR](#) [XI1443QGABL](#) [VX1526L](#) [VX901M](#) [VT211R](#) [VX1527L](#) [VX932X](#)
[VX2241L](#) [CH9140](#) [IWR6243ABGABLR](#) [ADBMS6822WCCSZ-RL](#) [RTL8367RB-VC-CG](#) [RTL8761BTV-CG](#) [SI4461-C2A-GMR](#)
[CC1260RGZT](#) [NRF51822-CEAA-R \(E0\)](#) [BGT24LTR11N16E6327XTSA1](#) [725TRX8-16K](#) [SI4455-C2A-GMR](#) [S2-LPQTR](#) [AT86RF232-ZX](#)