

### FEATURES

- 12-channel vertical driver
- 8 three-level drivers
- 4 two-level drivers
- Substrate clock driver
- Input logic supports a 1.6 V to 3.6 V range
- Output drivers support a -9.5 V to +15.5 V range
- 6 mm × 6 mm CSP\_BGA package with 0.65 mm pitch

### APPLICATIONS

- Digital still cameras
- Industrial cameras
- Surveillance cameras
- Medical imaging

### GENERAL DESCRIPTION

The [ADDI9023](#) is a 12-channel vertical driver for charge-coupled device (CCD) imaging applications. It includes eight three-level drivers and four two-level drivers. The input configuration can support up to nine individual vertical timing phases and eight shift gate signals. A separate substrate clock channel (SUBCK) is also included. Typical load drive capability for each channel is 3 nF.

The [ADDI9023](#) is specified over an operating temperature range of -25°C to +85°C.

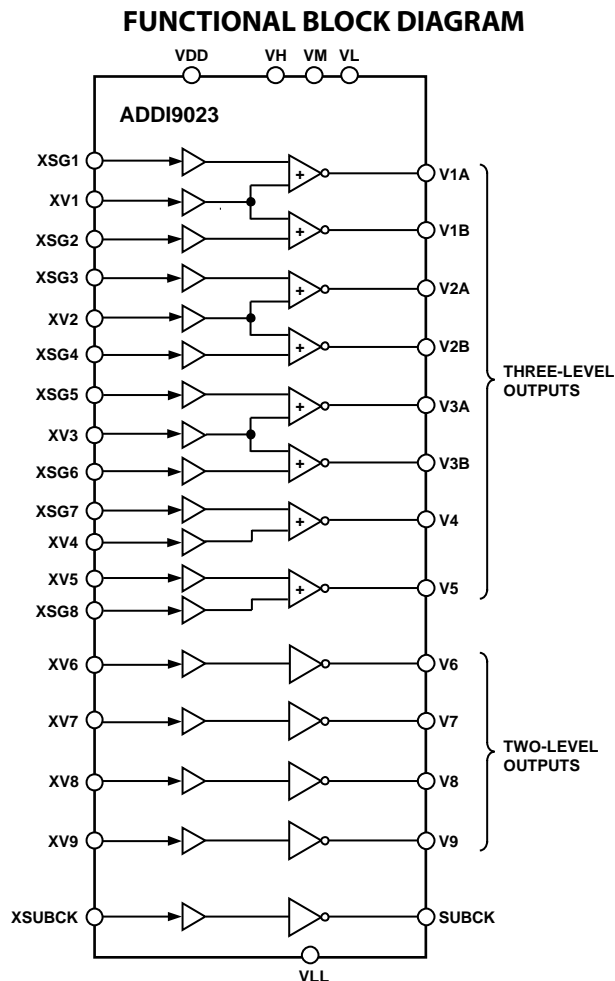

Figure 1.

#### Rev. 0

Information furnished by Analog Devices is believed to be accurate and reliable. However, no responsibility is assumed by Analog Devices for its use, nor for any infringements of patents or other rights of third parties that may result from its use. Specifications subject to change without notice. No license is granted by implication or otherwise under any patent or patent rights of Analog Devices. Trademarks and registered trademarks are the property of their respective owners.

**TABLE OF CONTENTS**

Features .....	1	Pin Configuration and Function Descriptions.....	6
Applications.....	1	Input/Output Logic States .....	8
General Description .....	1	Applications Information .....	10
Functional Block Diagram .....	1	Power-Up Sequence .....	10
Revision History .....	2	Power-Down Sequence.....	10
Specifications.....	3	Circuit Layout Information.....	11
Output Driver Specifications .....	4	Outline Dimensions .....	12
Absolute Maximum Ratings.....	5	Ordering Guide .....	12
Thermal Resistance .....	5		
ESD Caution.....	5		

**REVISION HISTORY****4/12—Revision 0: Initial Version**

## SPECIFICATIONS

Table 1.

Parameter	Test Conditions/Comments	Min	Typ	Max	Unit
TEMPERATURE RANGE					
Operating		-25		+85	°C
Storage		-65		+150	°C
V-DRIVER POWER SUPPLY VOLTAGES					
VDD	Input logic supply	1.6	3.0	3.6	V
VH	V-driver high supply	11.0	15.0	15.5	V
VL	V-driver low supply	-9.5	-7.5	-5.5	V
VM	V-driver midsupply	-1.5	0.0	+1.5	V
VLL	SUBCKV-driver low supply	-9.5	-7.5	-5.5	V
VH to VL, VLL	Maximum voltage from VH to VL, VLL			24	V
DC POWER SUPPLY CURRENTS					
$I_{VDD}$	VH = +15 V, VM = 0 V, VL = VLL = -7.5 V XVx = XSGx = 0 V XVx = XSGx = VDD			0.5 0.5	mA mA
$I_{VH}$	XVx = XSGx = 0 V XVx = XSGx = VDD			0.4 3.3	mA mA
$I_{VL}$	XVx = XSGx = 0 V XVx = XSGx = VDD			2.1 0.1	mA mA
$I_{VM}$	XVx = XSGx = 0 V XVx = XSGx = VDD			0.3 0.2	mA mA
$I_{VLL}$	XSUBCK = 0 V XSUBCK = VDD			0.3 0.1	mA mA
DIGITAL INPUTS					
High Level Input Voltage	VDD = 1.6 V to 3.6 V	VDD - 0.6			V
Low Level Input Voltage				0.6	V
High Level Input Current			10	50	μA
Low Level Input Current			10	50	μA
Input Capacitance			10		pF

**OUTPUT DRIVER SPECIFICATIONS**

VH = 15 V, VM = 0 V, VL, VLL = -7.5 V, T<sub>A</sub> = 25°C.

Table 2.

Parameter	Symbol	Test Conditions/Comments	Min	Typ	Max	Unit
<b>V1A TO V5</b>						
Delay Time, VL to VM and VM to VL	t <sub>PLM</sub> , t <sub>PML</sub>			37		ns
Delay Time, VM to VH and VH to VM	t <sub>PMH</sub> , t <sub>PHM</sub>			43		ns
Rise Time, VL to VM	t <sub>RLM</sub>	Load circuit: 20 Ω + 3 nF to GND		110		ns
Rise Time, VM to VH	t <sub>RMH</sub>	Load circuit: 20 Ω + 3 nF to GND		240		ns
Fall Time, VM to VL	t <sub>FML</sub>	Load circuit: 20 Ω + 3 nF to GND		180		ns
Fall Time, VH to VM	t <sub>FHM</sub>	Load circuit: 20 Ω + 3 nF to GND		130		ns
Output Currents		V1A to V5 = -7.25 V		14		mA
		V1A to V5 = -0.25 V		-23		mA
		V1A to V5 = +0.25 V		23		mA
		V1A to V5 = +14.75 V		-10		mA
On Resistance	R <sub>ON</sub>					
VH				23	35	Ω
VM				11	20	Ω
VL				17	25	Ω
<b>V6 TO V9</b>						
Delay Time, VL to VM and VM to VL	t <sub>PLM</sub> , t <sub>PML</sub>			37		ns
Rise Time, VL to VM	t <sub>RLM</sub>	Load circuit: 20 Ω + 3 nF to GND		110		ns
Fall Time, VM to VL	t <sub>FML</sub>	Load circuit: 20 Ω + 3 nF to GND		180		ns
Output Currents		V6 to V9 = -7.25 V		14		mA
		V6 to V9 = -0.25 V		-23		mA
On Resistance	R <sub>ON</sub>					
VM				11	20	Ω
VL				17	25	Ω
<b>SUBCK OUTPUT</b>						
Delay Time, VLL to VH	t <sub>PLH</sub>			47		ns
Delay Time, VH to VLL	t <sub>PHL</sub>			47		ns
Rise Time, VLL to VH	t <sub>RLH</sub>	Load circuit: 1 nF to GND		45		ns
Fall Time, VH to VLL	t <sub>FHL</sub>	Load circuit: 1 nF to GND		45		ns
Output Currents		SUBCK = -7.25 V		23		mA
		SUBCK = +14.75 V		-22		mA
VLL On Resistance	R <sub>ON</sub>			10	17	Ω

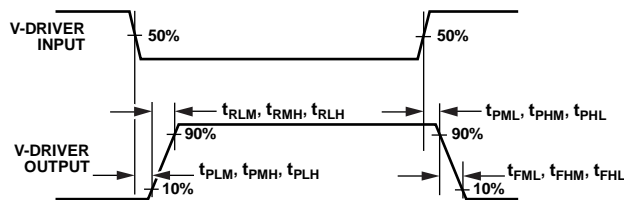

Figure 2. Definition of V-Driver Timing Specifications

## ABSOLUTE MAXIMUM RATINGS

Table 3.

Parameter	Rating
VDD to VSS	-0.3 V to +3.9 V
VH to VL, VLL	-0.3 V to +25.0 V
VH to VSS	-0.3 V to +17.0 V
VL to VSS	-17.0 V to +0.3 V
VM to VSS	-6.0 V to +3.0 V
VMM to VSS	-6.0 V to +3.0 V
VLL to VSS	-17.0 V to +0.3 V
V1A to V9 to VSS	VL - 0.3 V to VH + 0.3 V
VDREN to VSS	-0.3 V to VDD + 0.3 V
Junction Temperature	150°C
Lead Temperature (Soldering, 10 sec)	350°C

Stresses above those listed under Absolute Maximum Ratings may cause permanent damage to the device. This is a stress rating only; functional operation of the device at these or any other conditions above those indicated in the operational section of this specification is not implied. Exposure to absolute maximum rating conditions for extended periods may affect device reliability.

## THERMAL RESISTANCE

$\theta_{JA}$  is specified for the worst-case conditions, that is, a device soldered in a circuit board for surface-mount packages.

Table 4. Thermal Resistance

Package Type	$\theta_{JA}$	Unit
40-Lead CSP_BGA	46	°C/W

## ESD CAUTION



**ESD (electrostatic discharge) sensitive device.** Charged devices and circuit boards can discharge without detection. Although this product features patented or proprietary protection circuitry, damage may occur on devices subjected to high energy ESD. Therefore, proper ESD precautions should be taken to avoid performance degradation or loss of functionality.

### PIN CONFIGURATION AND FUNCTION DESCRIPTIONS

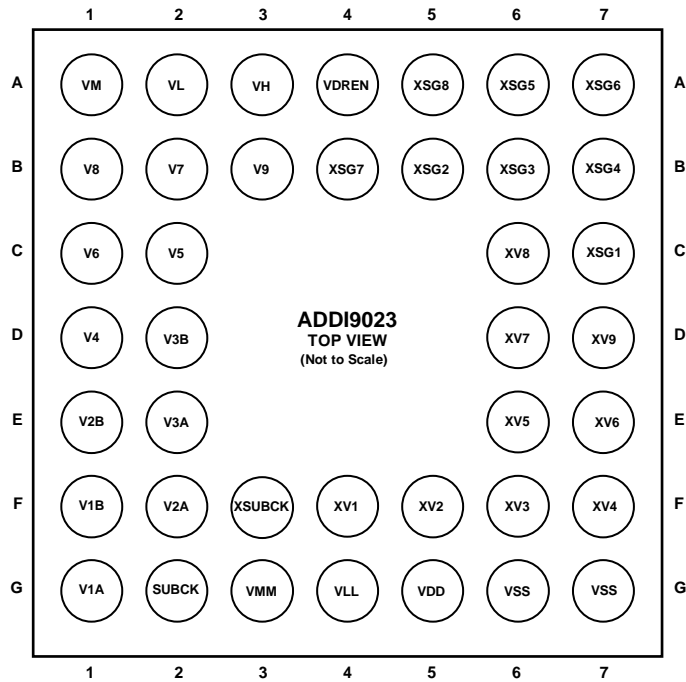

Figure 3. Pin Configuration

Table 5. Pin Function Descriptions

Pin No.	Mnemonic	Type <sup>1</sup>	Description
A1	VM	P	V-Driver Midsupply.
A2	VL	P	V-Driver Low Supply.
A3	VH	P	V-Driver High Supply.
A4	VDREN	DI	V-Driver Enable. Active high.
A5	XSG8	DI	Vertical Input.
A6	XSG5	DI	Vertical Input.
A7	XSG6	DI	Vertical Input.
B1	V8	VO2	CCD Vertical Transfer Clock.
B2	V7	VO2	CCD Vertical Transfer Clock.
B3	V9	VO2	CCD Vertical Transfer Clock.
B4	XSG7	DI	Vertical Input.
B5	XSG2	DI	Vertical Input.
B6	XSG3	DI	Vertical Input.
B7	XSG4	DI	Vertical Input.
C1	V6	VO2	CCD Vertical Transfer Clock.
C2	V5	VO3	CCD Vertical Transfer Clock (XV5 + XSG8).
C6	XV8	DI	Vertical Input.
C7	XSG1	DI	Vertical Input.
D1	V4	VO3	CCD Vertical Transfer Clock (XV4 + XSG7).
D2	V3B	VO3	CCD Vertical Transfer Clock (XV3 + XSG6).
D6	XV7	DI	Vertical Input.
D7	XV9	DI	Vertical Input.
E1	V2B	VO3	CCD Vertical Transfer Clock (XV2 + XSG4).
E2	V3A	VO3	CCD Vertical Transfer Clock (XV3 + XSG5).
E6	XV5	DI	Vertical Input.
E7	XV6	DI	Vertical Input.

Pin No.	Mnemonic	Type <sup>1</sup>	Description
F1	V1B	VO3	CCD Vertical Transfer Clock (XV1 + XSG2).
F2	V2A	VO3	CCD Vertical Transfer Clock (XV2 + XSG3).
F3	XSUBCK	DI	XSUBCK Input to SUBCK Buffer.
F4	XV1	DI	Vertical Input.
F5	XV2	DI	Vertical Input.
F6	XV3	DI	Vertical Input.
F7	XV4	DI	Vertical Input.
G1	V1A	VO3	CCD Vertical Transfer Clock (XV1 + XSG1).
G2	SUBCK	VO2	CCD Substrate Clock Output.
G3	VMM	P	SUBCK Output Driver Ground.
G4	VLL	P	V-Driver Low Supply for SUBCK Output.
G5	VDD	P	Digital Logic Supply.
G6	VSS	P	Digital Logic Ground.
G7	VSS	P	Digital Logic Ground.

<sup>1</sup> DI = digital input; P = power; VO2 = vertical driver output, two-level; VO3 = vertical driver output, three-level.

## INPUT/OUTPUT LOGIC STATES

**Table 6. V1A Output Polarity**

Vertical Driver Input		V1A Output
XV1	XSG1	
L	L	VH
L	H	VM
H	L	VL
H	H	VL

**Table 7. V1B Output Polarity**

Vertical Driver Input		V1B Output
XV1	XSG2	
L	L	VH
L	H	VM
H	L	VL
H	H	VL

**Table 8. V2A Output Polarity**

Vertical Driver Input		V2A Output
XV2	XSG3	
L	L	VH
L	H	VM
H	L	VL
H	H	VL

**Table 9. V2B Output Polarity**

Vertical Driver Input		V2B Output
XV2	XSG4	
L	L	VH
L	H	VM
H	L	VL
H	H	VL

**Table 10. V3A Output Polarity**

Vertical Driver Input		V3A Output
XV3	XSG5	
L	L	VH
L	H	VM
H	L	VL
H	H	VL

**Table 11. V3B Output Polarity**

Vertical Driver Input		V3B Output
XV3	XSG6	
L	L	VH
L	H	VM
H	L	VL
H	H	VL

**Table 12. V4 Output Polarity**

Vertical Driver Input		V4 Output
XV4	XSG7	
L	L	VH
L	H	VM
H	L	VL
H	H	VL

**Table 13. V5 Output Polarity**

Vertical Driver Input		V5 Output
XV5	XSG8	
L	L	VH
L	H	VM
H	L	VL
H	H	VL

**Table 14. V6 to V9 Output Polarity**

Vertical Driver Input	V6, V7, V8, or V9 Output
XV6, XV7, XV8, or XV9	
L	VM
H	VL

**Table 15. SUBCK Output Polarity**

Vertical Driver Input	SUBCK Output
XSUBCK	
L	VH
H	VLL



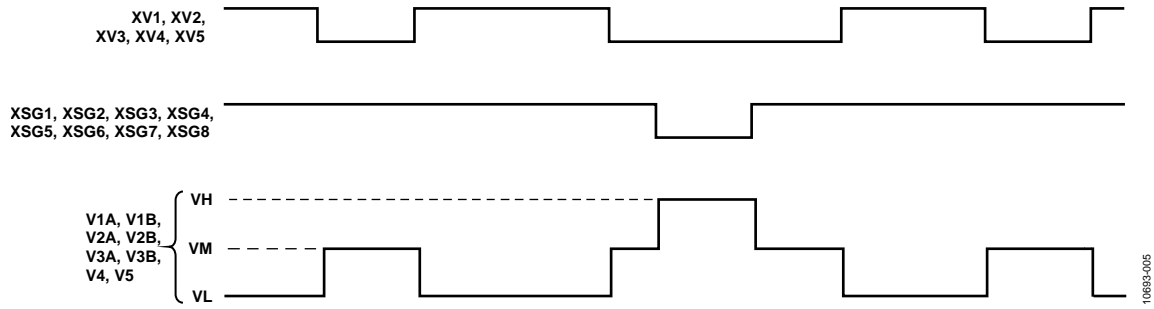

Figure 4. Three-Level V-Driver Output Polarities

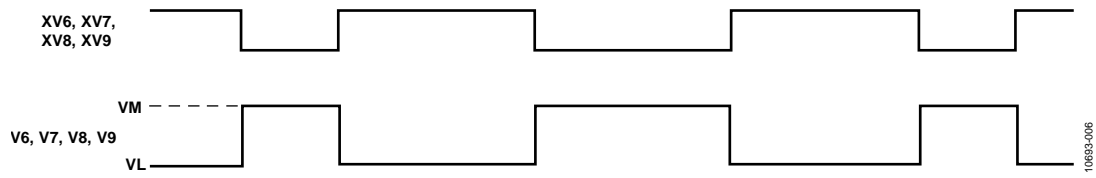

Figure 5. Two-Level V-Driver Output Polarities

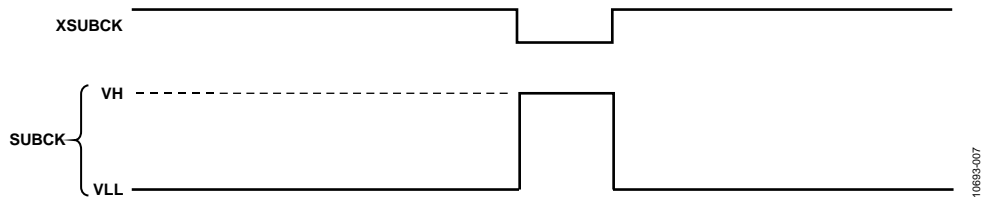

Figure 6. SUBCK Output Polarity

## APPLICATIONS INFORMATION

### POWER-UP SEQUENCE

When the [ADDI9023](#) is powered up, the following sequence is recommended (refer to Figure 7 for each step). Note that VH is powered on before VL but, depending on CCD restrictions, VH and VL can also be powered on simultaneously.

1. Turn on the VDD power supply, either 1.8 V or 3.3 V. After VDD settles, the logic inputs from the timing generator (XV, XSG, XSUBCK) can become active. Keep VDREN low during this time.
2. Turn on the VH power supply, typically +12 V to +15 V.

3. Turn on the VL/VLL power supply, typically -6 V to -9 V.
4. Take the VDREN pin high to enable the V-driver outputs. VDREN must remain high throughout normal vertical timing operation.

### POWER-DOWN SEQUENCE

When the [ADDI9023](#) is powered down, reverse the procedure shown in Figure 7.

1. Take the VDREN pin low to disable the V-driver outputs.
2. Turn off the VL/VLL and VH power supplies.
3. Turn off the VDD power supply.

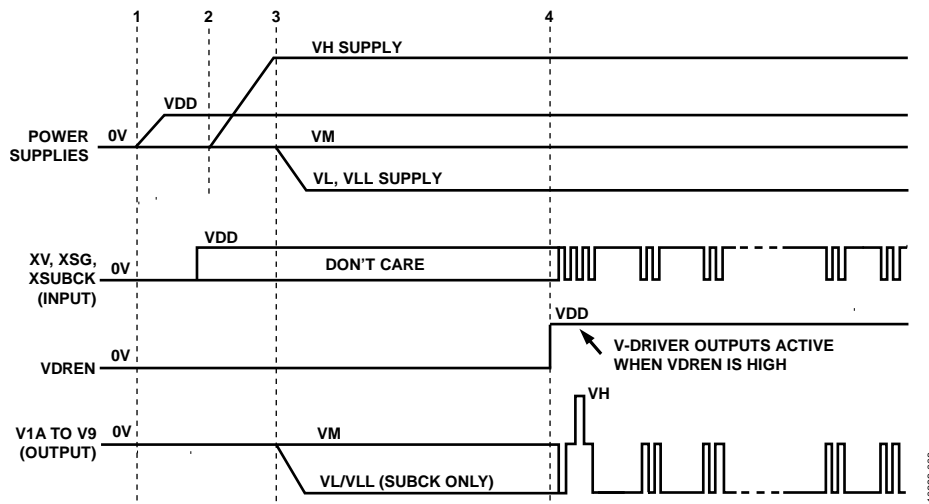

Figure 7. Recommended Power-Up Sequence

**CIRCUIT LAYOUT INFORMATION**

The recommended circuit configuration is shown in Figure 8. Each supply pin should have a high quality 0.1  $\mu\text{F}$  capacitor connected to ground. The VH and VL supplies should have an

additional bypass capacitor, such as a 1.0  $\mu\text{F}$  to 22  $\mu\text{F}$  capacitor, depending on CCD and performance requirements. Connect the ground pins (VSS, VM, and VMM) to a common ground plane.

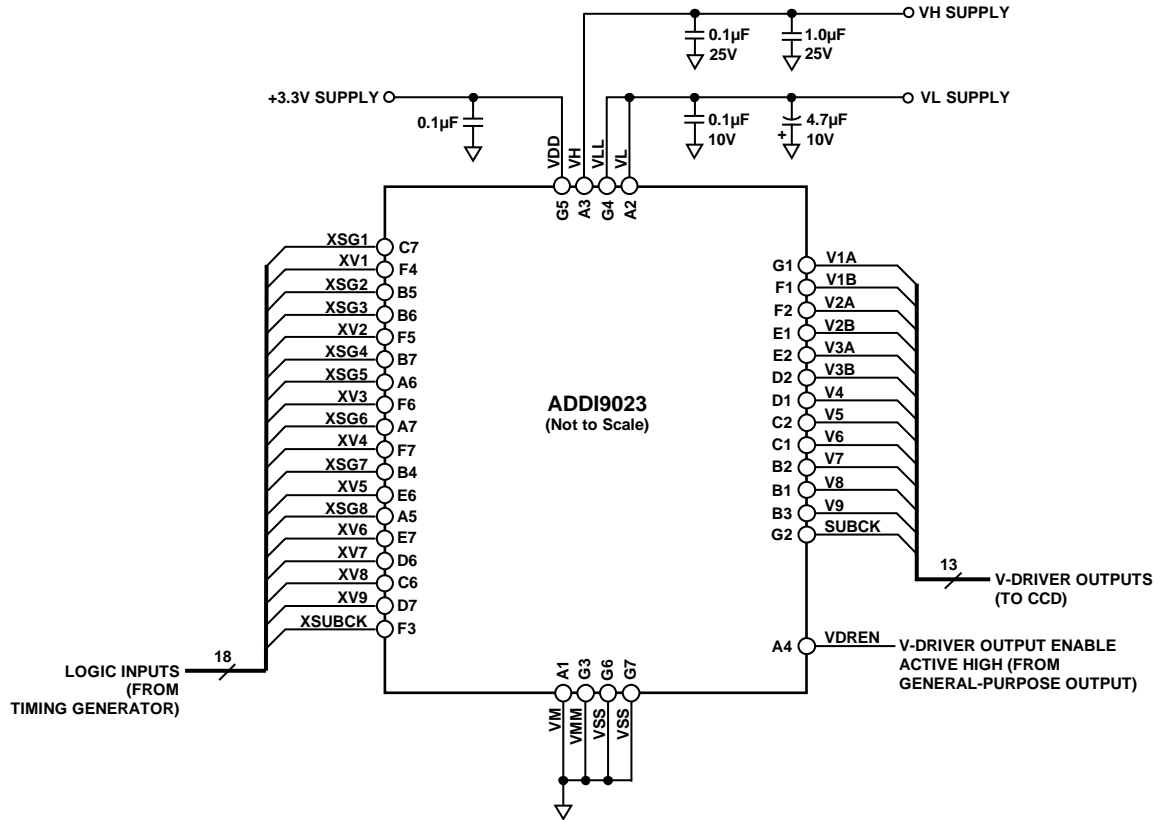

Figure 8. Typical Circuit Configuration

10693-009



## X-ON Electronics

Largest Supplier of Electrical and Electronic Components

*Click to view similar products for [Display Drivers & Controllers](#) category:*

*Click to view products by [Analog Devices](#) manufacturer:*

Other Similar products are found below :

[ICB2FL01G](#) [HV5812PJ-G-M904](#) [TW8813-LB2-GR](#) [TW8811-PC2-GR](#) [MAX1839EEP+](#) [TW9907-TA1-GR](#) [LX27901IDW](#) [SSD2828QN4](#)  
[MAX7370ETG+](#) [DLPA1000YFFT](#) [ICB2FL01GXUMA2](#) [DLP2000FQC](#) [PAD1000YFFR](#) [S1D13746F01A600](#) [FIN324CMLX](#) [AD8387JSVZ](#)  
[DLPC6421ZPC](#) [HV852K7-G](#) [HV859K7-G](#) [HV857K7-G](#) [DIO2133CT14](#) [S1D13L03F00A100-40](#) [TW2836-BA1-GR](#) [SSD2829QL9](#)  
[MAX749CSA+T](#) [MAX4820EUP+T](#) [ICL7135CAI+](#) [ICL7135CMH+D](#) [ICL7137CMH+D](#) [MAX14515AEWA+](#) [MAX14521EETG+](#)  
[MAX25221BATJ/V+](#) [DS3882E+C](#) [S1D13748B00B100](#) [S1D13A05B00B200](#) [MAX3738ETG+T](#) [MAX14514ETD+](#) [MAX4990ETD+T](#)  
[MAX8722CEEG+](#) [MAX749CPA+](#) [MAX8785AETI+](#) [ICL7135CQI+](#) [HV518PJ-G-M903](#) [HV5812P-G](#) [HV5812PJ-G](#) [HV7224PG-G](#)  
[HV853K7-G](#) [HV860K7-G](#) [HV6810WG-G](#) [HV823LG-G](#)