

FEATURES

Frequency range (global ISM band)
 2400 MHz to 2483.5 MHz
Programmable data rates and modulation
 IEEE 802.15.4-2006-compatible (250 kbps)
 GFSK/FSK/GMSK/MSK modulation
 50 kbps to 2000 kbps data rates
Low power consumption
 19 mA (typical) in receive mode
 21.5 mA (typical) in transmit mode ($P_o = 3$ dBm)
 1.7 μ A, 32 kHz crystal oscillator wake-up mode
High sensitivity (IEEE 802.15.4-2006)
 -95 dBm at 250 kbps
High sensitivity (0.1% BER)
 -96 dBm at 62.5 kbps (GFSK)
 -93 dBm at 500 kbps (GFSK)
 -90 dBm at 1 Mbps (GFSK)
 -87.5 dBm at 2 Mbps (GFSK)
Programmable output power
 -20 dBm to +4.8 dBm in 2 dB steps
Integrated voltage regulators
 1.8 V to 3.6 V input voltage range
Excellent receiver selectivity and blocking resilience
 Zero-IF architecture
 Complies with EN300 440 Class 2, EN300 328, FCC CFR47
 Part 15, ARIB STD-T66
Digital RSSI measurement
Fast automatic VCO calibration
Automatic RF synthesizer bandwidth optimization

On-chip low power processor performs
 Radio control
 Packet management
Packet management support
 Insertion/detection of preamble/SWD/CRC/address
 IEEE 802.15.4-2006 frame filtering
 IEEE 802.15.4-2006 CSMA/CA unslotted modes
Flexible 256-byte transmit/receive data buffer
 IEEE 802.15.4-2006 and GFSK/FSK SPORT modes
Fast settling automatic frequency control
Flexible multiple RF port interface
 External PA/LNA support hardware
 Switched antenna diversity support
Wake-up timer
Very few external components
 Integrated PLL loop filter, receive/transmit switch, battery
 monitor, temperature sensor, 32 kHz RC and crystal
 oscillators
Flexible SPI control interface with block read/write access
Small form factor 5 mm \times 5 mm 32-lead LFCSP package

APPLICATIONS

Wireless sensor networks
 Automatic meter reading/smart metering
 Industrial wireless control
 Healthcare
 Wireless audio/video
 Consumer electronics
 ZigBee

FUNCTIONAL BLOCK DIAGRAM

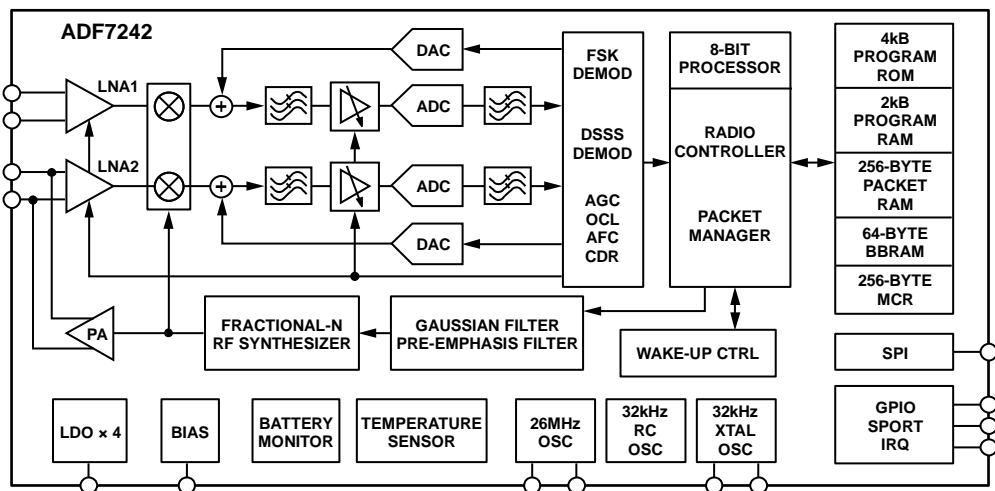

Figure 1

Rev. 0

Information furnished by Analog Devices is believed to be accurate and reliable. However, no responsibility is assumed by Analog Devices for its use, nor for any infringements of patents or other rights of third parties that may result from its use. Specifications subject to change without notice. No license is granted by implication or otherwise under any patent or patent rights of Analog Devices. Trademarks and registered trademarks are the property of their respective owners.

TABLE OF CONTENTS

Features	1	IEEE 802.15.4-2006 Receive Timing and Control	50
Applications	1	Clear Channel Assessment (CCA)	51
Functional Block Diagram	1	Link Quality Indication (LQI)	52
Revision History	3	IEEE 802.15.4 Automatic TX-to-RX Turnaround Mode	53
General Description	4	IEEE 802.15.4 Frame Filtering, Automatic Acknowledge, and Automatic CSMA/CA	53
Specifications	6	Receiver in GFSK/FSK Mode	56
General Specifications	6	Receiver Radio Blocks	61
RF Frequency Synthesizer Specifications	6	SPORT Interface	63
Transmitter Specifications	7	GFSK/FSK SPORT Mode	63
Receiver Specifications	8	IEEE 802.15.4-2006 SPORT Mode	65
Auxiliary Specifications	11	Device Configuration	66
Current Consumption Specifications	12	Configuration Values Common to IEEE 802.15.4 and GFSK/FSK Modes	67
Timing and Digital Specifications	13	Configuration Values for GFSK/FSK Packet and SPORT Modes	67
Timing Diagrams	15	Configuration Values for IEEE 802.15.4-2006 Packet and SPORT Modes	68
IEEE 802.15.4 TX SPORT Mode Timing Diagrams	18	RF Port Configurations/Antenna Diversity	69
GFSK/FSK RX SPORT Mode Timing Diagrams	18	Auxillary Functions	70
Absolute Maximum Ratings	22	Temperture Sensor	70
ESD Caution	22	Battery Monitor	70
Pin Configuration and Function Descriptions	23	Wake-Up Controller (WUC)	70
Typical Performance Characteristics	25	Transmit Test Modes	71
Terminology	34	Serial Peripheral interface (SPI)	72
Radio Controller	35	General Characteristics	72
Sleep Modes	37	Command Access	72
RF Frequency Synthesizer	38	Status Word	72
RF Frequency Synthesizer Calibration	38	Memory Map	74
RF Frequency Synthesizer Bandwidth	38	BBRAM	74
RF Channel Frequency Programming	39	Modem Configuration RAM (MCR)	74
Reference Crystal Oscillator	39	Program ROM	74
Transmitter	40	Program RAM	74
Transmit Operating Modes	40	Packet RAM	74
Transmitter in IEEE 802.15.4-2006 Mode	40	Memory Access	76
IEEE 802.15.4 Automatic RX-To-TX Turnaround Mode	43	Writing to the ADF7242	77
Transmitter in GFSK/FSK Mode	43	Reading from the ADF7242	77
Power Amplifier	46	Downloadable Firmware Modules	80
Receiver	48	Interrupt Controller	81
Receive Operating Modes	48		
Receiver in IEEE 802.15.4-2006 Mode	48		
Receiver Calibration	49		

Configuration	81	Register Map	87
Description of Interrupt Sources	82	Outline Dimensions.....	105
Applications Circuits	83	Ordering Guide	105

REVISION HISTORY

7/10—Revision 0: Initial Version

GENERAL DESCRIPTION

The ADF7242 is a highly integrated, low power, and high performance transceiver for operation in the global 2.4 GHz ISM band. It is designed with emphasis on flexibility, robustness, ease of use, and low current consumption. The IC supports the IEEE 802.15.4-2006 2.4 GHz PHY requirements as well as proprietary GFSK/FSK/GMSK/MSK modulation schemes in both packet and data streaming modes. With a minimum number of external components, it achieves compliance with the FCC CFR47 Part 15, ETSI EN 300 440 (Equipment Class 2), ETSI EN 300 328 (FHSS, DR > 250 kbps), and ARIB STD T-66 standards.

The ADF7242 complies with the IEEE 802.15.4-2006 2.4 GHz PHY requirements with a fixed data rate of 250 kbps and DSSS-OQPSK modulation. With its support of GFSK/FSK/GMSK/MSK modulation schemes, the IC can operate over a wide range of data rates from 50 kbps to 2 Mbps and is, therefore, equally suitable for proprietary applications in the areas of smart metering, industrial control, home and building automation, and consumer electronics. In addition, the agile frequency synthesizer of the ADF7242, together with short turnaround times, facilitates the implementation of FHSS systems.

The transmitter path of the ADF7242 is based on a direct closed-loop VCO modulation scheme using a low noise fractional-N RF frequency synthesizer. The automatically calibrated VCO operates at twice the fundamental frequency to reduce spurious emissions and avoid PA pulling effects. The bandwidth of the RF frequency synthesizer is automatically optimized for transmit and receive operations to achieve optimum phase noise, modulation quality, and synthesizer settling time performance. The transmitter output power is programmable from -20 dBm to +4 dBm with automatic PA ramping to meet transient spurious specifications. An integrated biasing and control circuit is available in the IC to significantly simplify the interface to external PAs.

The receive path is based on a zero-IF architecture enabling very high blocking resilience and selectivity performance, which are critical performance metrics in interference dominated environments such as the 2.4 GHz band. In addition, the architecture does not suffer from any degradation of blocker rejection in the image channel, which is typically found in low IF receivers. In GFSK/FSK modes, the receiver features a high speed automatic frequency control (AFC) loop, which allows the frequency synthesizer to find and correct any frequency errors in the received packet.

The IC can operate with a supply voltage between 1.8 V and 3.6 V with very low power consumption in receive and transmit modes while maintaining its excellent RF performance, making it especially suitable for battery-powered systems.

The ADF7242 features a flexible dual-port RF interface that can be used with an external LNA and/or PA in addition to supporting switched antenna diversity.

The ADF7242 incorporates a very low power custom 8-bit processor that supports a number of transceiver management functions. These functions are handled by the two main modules of the processor; the radio controller and the packet manager.

The radio controller manages the state of the IC in various operating modes and configurations. The host MCU can use single byte commands to interface to the radio controller. The packet manager is highly flexible and supports various packet formats. In transmit mode, the packet manager can be configured to add preamble, sync, and CRC words to the payload data stored in the on-chip packet RAM. In receive mode, the packet manager can detect and generate an interrupt to the MCU upon receiving valid sync or CRC words, and store the received data payload in the packet RAM. A total of 256 bytes of transmit and receive packet RAM space is provided to decouple the over-the-air data rate from the host MCU processing speed. Thus, the ADF7242 packet manager eases the processing burden on the host MCU and saves the overall system power consumption.

In addition, for applications that require data streaming, a synchronous bidirectional serial port (SPORT) provides bit-level input/output data, and has been designed to directly interface to a wide range of DSPs, such as ADSP-21xx, SHARC®, TigerSHARC®, and Blackfin®. The SPORT interface can optionally be used for GFSK/FSK as well as IEEE 802.15.4-2006 modes.

The processor also permits the download and execution of a set of firmware modules, which include IEEE 802.15.4 automatic modes, such as node address filtering, as well as unslotted CSMA/CA. Execution code for these firmware modules is available from Analog Devices, Inc.

To further optimize the system power consumption, the ADF7242 features an integrated low power 32 kHz RC wake-up oscillator, which is calibrated from the 26 MHz crystal oscillator while the transceiver is active. Alternatively, an integrated 32 kHz crystal oscillator can be used as a wake-up timer for applications requiring very accurate wake-up timing. A battery backed-up RAM (BBRAM) is available on the IC where IEEE 802.15.4-2006 network node addresses can be retained when the IC is in the sleep state.

The ADF7242 also features a very flexible interrupt controller, which provides MAC-level and PHY-level interrupts to the host MCU. The IC is equipped with a SPI interface, which allows burst-mode data transfer for high data throughput efficiency. The IC also integrates a temperature sensor with digital read-back and a battery monitor.

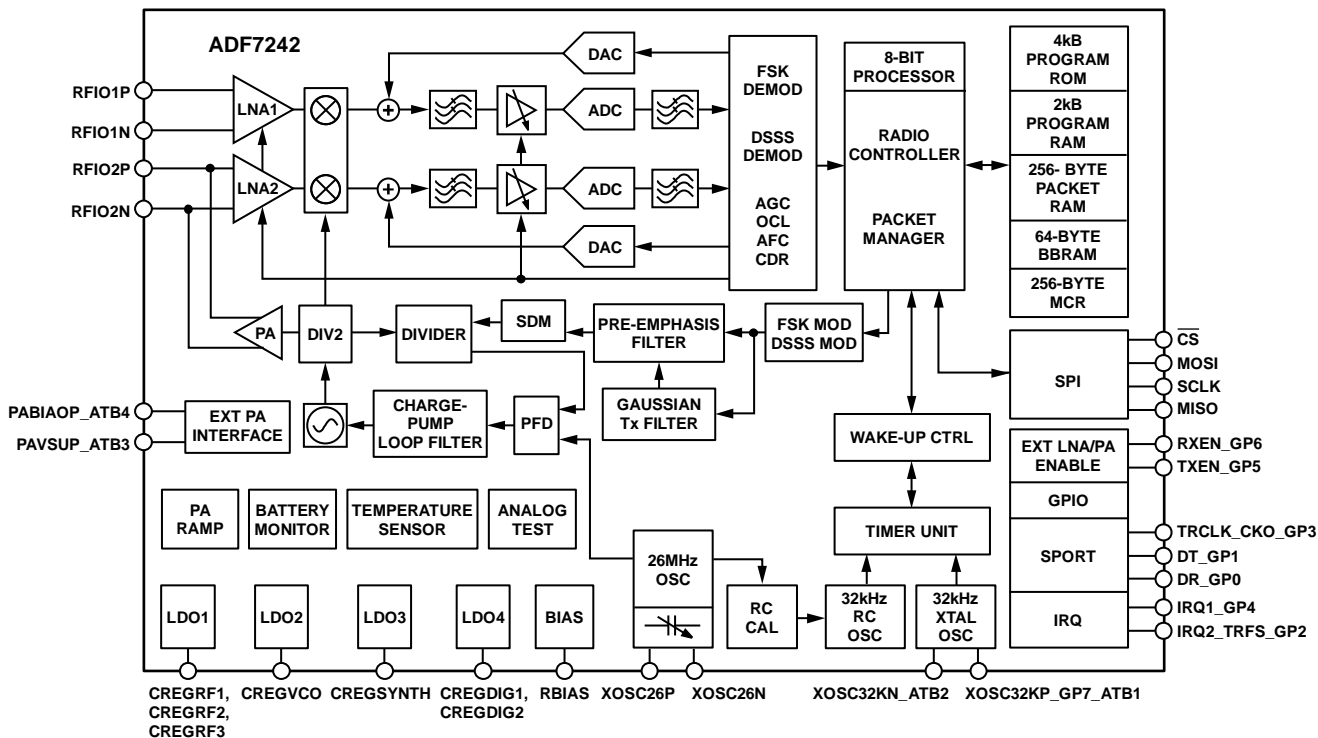

Figure 2. Detailed Functional Block Diagram

08812-011

ADF7242

SPECIFICATIONS

VDD_BAT = 1.8 V to 3.6 V, GND = 0 V, T_A = T_{MIN} to T_{MAX}, unless otherwise noted. Typical specifications are at VDD_BAT = 3.6 V, T_A = 25°C, f_{CHANNEL} = 2450 MHz. All measurements are performed using the ADF7242 reference design, RFIO2 port, unless otherwise noted.

GENERAL SPECIFICATIONS

Table 1.

Parameter	Min	Typ	Max	Unit	Test Conditions
GENERAL PARAMETERS					
Voltage Supply Range					
VDD_BAT Input	1.8		3.6	V	
Frequency Range	2400		2483.5	MHz	
Operating Temperature Range	-40		+85	°C	
Data Rate					
GFSK/FSK Mode	50		2000	kbps	
IEEE 802.15.4-2006 Mode		250		kbps	
Resolution		100		bps	Applies to FSK modes only

RF FREQUENCY SYNTHESIZER SPECIFICATIONS

Table 2.

Parameter	Min	Typ	Max	Unit	Test Conditions
CHANNEL FREQUENCY RESOLUTION		10		kHz	Applies to GFSK/FSK modes
PHASE ERROR		3		Degrees	Receive mode; any data rate, IEEE 802.15.4-2006 or GFSK/FSK mode; integration bandwidth from 10 kHz to 400 kHz
		1.5		Degrees	Transmit mode; IEEE 802.15.4-2006, 2 Mbps to 290 kbps, GFSK/FSK/GMSK/MSK mode; integration bandwidth from 10 kHz to 1800 kHz
		2		Degrees	Transmit mode; 289.9 kbps to 184 kbps GFSK/FSK/GMSK/MSK mode; integration bandwidth from 10 kHz to 800 kHz
		2.5		Degrees	Transmit mode; 183.9 kbps to 50 kbps GFSK/FSK/GMSK/MSK mode; integration bandwidth from 10 kHz to 500 kHz
VCO CALIBRATION TIME		52		μs	Applies to all modes
SYNTHESIZER SETTTLING TIME					Frequency synthesizer settled to <±5 ppm of the target frequency within this time following a VCO calibration
		53		μs	Receive mode; any data rate, IEEE 802.15.4-2006 or GFSK/FSK mode
		80		μs	Transmit mode; IEEE 802.15.4-2006, 2 Mbps to 289.6 kbps GFSK/FSK mode
		39		μs	Transmit mode; 289.7 kbps to 184 kbps GFSK/FSK mode
		35		μs	Transmit mode; 183.9 kbps to 50 kbps GFSK/FSK mode
PHASE NOISE		-135		dBc/Hz	Receive mode; any data rate, IEEE 802.15.4-2006 or GFSK/FSK mode
		-145		dBc/Hz	10 MHz frequency offset
					≥50 MHz frequency offset
REFERENCE AND CLOCK-RELATED SPURIOUS		70		dBc	Receive mode; IEEE 802.15.4-2006 or GFSK/FSK mode; f _{CHANNEL} = 2405 MHz, 2450 MHz, and 2480 MHz

Parameter	Min	Typ	Max	Unit	Test Conditions
INTEGER BOUNDARY SPURS		60		dBc	Receive mode; IEEE 802.15.4-2006 or GFSK/FSK mode; measured at 400 kHz offset from $f_{\text{CHANNEL}} = 2405 \text{ MHz}, 2418 \text{ MHz}, 2431 \text{ MHz}, 2444 \text{ MHz}, 2457 \text{ MHz}, 2470 \text{ MHz}$
CRYSTAL OSCILLATOR					
Crystal Frequency		26		MHz	Parallel load resonant crystal Guarantees maximum crystal frequency error of 0.2 ppm; 33 pF on XOSC26P and XOSC26N 15 pF load on XOSC26N and XOSC26P
Maximum Parallel Load Capacitance		18		pF	
Minimum Parallel Load Capacitance		7		pF	
Maximum Crystal ESR		365.3		Ω	
Sleep-to-Idle Wake-Up Time		300		μs	

TRANSMITTER SPECIFICATIONS

Table 3.

Parameter	Min	Typ	Max	Unit	Test Conditions
GENERAL TRANSMITTER SPECIFICATIONS					
Maximum Transmit Power		3		dBm	Refer to Power Amplifier section for details on how to enable this mode
Minimum Transmit Power		-25		dBm	
Maximum Transmit Power (High Power Mode)		4.8		dBm	
Minimum Transmit Power(High Power Mode)		-22		dBm	
Transmit Power Variation		2		dB	Transmit power = 3 dBm, $f_{\text{CHANNEL}} = 2400 \text{ MHz to } 2483.5 \text{ MHz}, T_A = -40^\circ\text{C to } +85^\circ\text{C}, VDD_BAT = 1.8 \text{ V to } 3.6 \text{ V}$
Transmit Power Control Resolution		2		dB	Transmit power = 3dBm
Optimum PA Matching Impedance		43.7 + 35.2j		Ω	For maximum transmit power = 3 dBm
Harmonics and Spurious Emissions					
Compliance with ETSI EN 300 440					
25 MHz to 30 MHz			-36	dBm	Unmodulated carrier, 10 kHz RBW ¹
30 MHz to 1 GHz			-36	dBm	Unmodulated carrier, 100 kHz RBW ¹
47 MHz to 74 MHz, 87.5 MHz to 118 MHz, 174 MHz to 230 MHz, 470 MHz to 862 MHz			-54	dBm	Unmodulated carrier, 100 kHz RBW ¹
Otherwise Above 1 GHz			-30	dBm	Unmodulated carrier, 1 MHz RBW ¹
Compliance with ETSI EN 300 328					
1800 MHz to 1900 MHz			-47	dBm	Unmodulated carrier
5150 MHz to 5300 MHz			-97	dBm/Hz	
Compliance with FCC CFR47, Part 15					
4.5 GHz to 5.15 GHz			-41	dBm	1 MHz RBW ¹
7.25 GHz to 7.75 GHz			-41	dBm	1 MHz RBW ¹
TRANSMIT PATH IEEE 802.15.4-2006 MODE					
Transmit EVM		2		%	Measured using Rohde & Schwarz FSU vector analyzer with Zigbee™ option $f_{\text{CHANNEL}} = 2405 \text{ MHz to } 2480 \text{ MHz}, T_A = -40^\circ\text{C to } +85^\circ\text{C}, VDD_BAT = 1.8 \text{ V to } 3.6 \text{ V}$ RBW = 100 kHz; $ f - f_{\text{CHANNEL}} > 3.5 \text{ MHz}$
Transmit EVM Variation		1		%	
Transmit PSD Mask		-56		dBm	
Transmit 20 dB Bandwidth		2252		MHz	
TRANSMIT PATH GFSK/FSK MODE					
Frequency Deviation Resolution		10		kHz	Gaussian filter available for 2000 kbps, 1000 kbps, 500 kbps, 250 kbps, 125 kbps and 62.5 kbps only
Gaussian Filter BT		0.5			

ADF7242

Parameter	Min	Typ	Max	Unit	Test Conditions
Transmit Modulation Phase Error		7		Degrees	2 Mbps ($f_{DEV} = \pm 500$ kHz) GFSK SPORT mode, transmitter output power = 3 dBm
		6.5		Degrees	1 Mbps ($f_{DEV} = \pm 250$ kHz) GFSK SPORT mode, transmitter output power = 3 dBm
		4.5		Degrees	500 kbps ($f_{DEV} = \pm 250$ kHz) GFSK SPORT mode, transmitter output power = 3 dBm
		6		Degrees	250 kbps ($f_{DEV} = \pm 130$ kHz) GFSK SPORT mode, transmitter output power = 3 dBm
		4		Degrees	125 kbps ($f_{DEV} = \pm 60$ kHz) FSK SPORT mode, transmitter output power = 3 dBm
Transmit Modulation Error Rate (MER)		24		dB	2 Mbps GFSK SPORT mode, transmitter output power = 3 dBm; measured as the standard deviation from ± 500 kHz frequency deviation
		24		dB	1 Mbps GFSK SPORT mode, transmitter output power = 3 dBm; measured as the standard deviation from ± 250 kHz frequency deviation
		24		dB	500 kbps GFSK SPORT mode, transmitter output power = 3 dBm; measured as the standard deviation from ± 250 kHz frequency deviation
		24		dB	250 kbps GFSK SPORT mode, transmitter output power = 3 dBm; measured as the standard deviation from ± 130 kHz frequency deviation
		22		dB	125 kbps FSK SPORT mode, transmitter output power = 3 dBm; measured as the standard deviation from ± 60 kHz frequency deviation
Transmit 20 dB Bandwidth					
2 Mbps GFSK SPORT Mode		2520		kHz	2 Mbps ($f_{DEV} = \pm 500$ kHz) GFSK SPORT mode
1 Mbps GFSK SPORT Mode		1250		kHz	1 Mbps ($f_{DEV} = \pm 250$ kHz) GFSK SPORT mode
500 kbps GFSK SPORT Mode		985		kHz	500 kbps ($f_{DEV} = \pm 250$ kHz) GFSK SPORT mode
250 kbps GFSK SPORT Mode		520		kHz	250 kbps ($f_{DEV} = \pm 130$ kHz) GFSK SPORT mode
125 kbps GFSK SPORT Mode		302		kHz	125 kbps ($f_{DEV} = \pm 60$ kHz) FSK SPORT mode
62.5 kbps FSK SPORT Mode		226		kHz	62.5 kbps ($f_{DEV} = \pm 60$ kHz) FSK SPORT mode
Transmit Adjacent Channel Power					
\pm First Channel		-53.5		dBm	2 Mbps GFSK SPORT mode, 5 MHz channel spacing
\pm Second Channel		-54.5		dBm	2.2 MHz channel bandwidth, transmitter output power = 3 dBm
\pm First Channel		-27		dBm	250 kbps FSK SPORT mode, 300 kHz channel spacing
\pm Second Channel		-51.5		dBm	250 kHz channel bandwidth, transmitter output power = 3 dBm

¹ RBW = resolution bandwidth.

RECEIVER SPECIFICATIONS

Table 4.

Parameter	Min	Typ	Max	Unit	Test Conditions
GENERAL RECEIVER SPECIFICATIONS					
RF Front-End LNA and Mixer IIP3		-13.6		dBm	At maximum gain, $f_{BLOCKER1} = 5$ MHz, $f_{BLOCKER2} = 10.1$ MHz, $P_{RF,IN} = -35$ dBm
		-12.6		dBm	At maximum gain, $f_{BLOCKER1} = 20$ MHz, $f_{BLOCKER2} = 40.1$ MHz, $P_{RF,IN} = -35$ dBm
		-10.5		dBm	At maximum gain, $f_{BLOCKER1} = 40$ MHz, $f_{BLOCKER2} = 80.1$ MHz, $P_{RF,IN} = -35$ dBm

Parameter	Min	Typ	Max	Unit	Test Conditions
RF Front-End LNA and Mixer IIP2		24.7		dBm	At maximum gain, $f_{BLOCKER1} = 5$ MHz, $f_{BLOCKER2} = 5.5$ MHz, $P_{RF,IN} = -50$ dBm
RF Front-End LNA and Mixer 1 dB Compression Point		-20.5		dBm	At maximum gain
Receiver LO Level at RFIO2 Port		-100		dBm	IEEE 802.15.4 packet mode
LNA Input Impedance at RFIO1 Port		50.2 – 52.2j		Ω	Measured in RX state
LNA Input Impedance at RFIO2 Port		74.3 – 10.7j		Ω	Measured in RX state
Receive Spurious Emissions Compliant with EN 300 440					
30 MHz to 1000 MHz			-57	dBm	
1 GHz to 12.75 GHz			-47	dBm	
RECEIVE PATH IEEE 802.15.4-2006 MODE					
Sensitivity ($P_{rf,in,min}$, 802154)		-95		dBm	1% PER with PSDU length of 20 bytes according to the IEEE 802.15.4-2006 standard
Saturation Level		-15		dBm	1% PER with PSDU length of 20 bytes
CW Blocker Rejection					
±5 MHz		55		dB	$P_{RF,iN} = P_{RF,iN,MIN}, 802154 + 3$ dB
±10 MHz		60		dB	$P_{RF,iN} = P_{RF,iN,MIN}, 802154 + 3$ dB
±20 MHz		63		dB	$P_{RF,iN} = P_{RF,iN,MIN}, 802154 + 3$ dB
±30 MHz		64		dB	$P_{RF,iN} = P_{RF,iN,MIN}, 802154 + 3$ dB
Modulated Blocker Rejection					
±5 MHz		48		dB	$P_{RF,iN} = P_{RF,iN,MIN}, 802154 + 3$ dB
±10 MHz		61		dB	$P_{RF,iN} = P_{RF,iN,MIN}, 802154 + 3$ dB
±15 MHz		62.5		dB	$P_{RF,iN} = P_{RF,iN,MIN}, 802154 + 3$ dB
±20 MHz		65		dB	$P_{RF,iN} = P_{RF,iN,MIN}, 802154 + 3$ dB
±30 MHz		65		dB	$P_{RF,iN} = P_{RF,iN,MIN}, 802154 + 3$ dB
Co-Channel Rejection		-6		dB	$P_{rf,iN} = P_{rf,iN,MIN} + 10$ dB Modulated Blocker
Out-of Band Blocker Rejection					
-5 MHz		-34.2		dBm	$P_{RF,iN} = P_{RF,iN,MIN}, 802154 + 3$ dB, measured at $f_{CHANNEL} = 2405$ MHz
-10 MHz		-30.7		dBm	$P_{RF,iN} = P_{RF,iN,MIN}, 802154 + 3$ dB, measured at $f_{CHANNEL} = 2405$ MHz
-20 MHz		-29.7		dBm	$P_{RF,iN} = P_{RF,iN,MIN}, 802154 + 3$ dB, measured at $f_{CHANNEL} = 2405$ MHz
-30 MHz		-25.7		dBm	$P_{RF,iN} = P_{RF,iN,MIN}, 802154 + 3$ dB, measured at $f_{CHANNEL} = 2405$ MHz
-60 MHz		-24.2		dBm	$P_{RF,iN} = P_{RF,iN,MIN}, 802154 + 3$ dB, measured at $f_{CHANNEL} = 2405$ MHz
+5 MHz		-33.4		dBm	$P_{RF,iN} = P_{RF,iN,MIN}, 802154 + 3$ dB, measured at $f_{CHANNEL} = 2480$ MHz
+10 MHz		-29.9		dBm	$P_{RF,iN} = P_{RF,iN,MIN}, 802154 + 3$ dB, measured at $f_{CHANNEL} = 2480$ MHz
+20 MHz		-28.2		dBm	$P_{RF,iN} = P_{RF,iN,MIN}, 802154 + 3$ dB, measured at $f_{CHANNEL} = 2480$ MHz
+30 MHz		-23.7		dBm	$P_{RF,iN} = P_{RF,iN,MIN}, 802154 + 3$ dB, measured at $f_{CHANNEL} = 2480$ MHz
+60 MHz		-29.9		dBm	$P_{RF,iN} = P_{RF,iN,MIN}, 802154 + 3$ dB, measured at $f_{CHANNEL} = 2480$ MHz
Receiver Channel Bandwidth		2252		kHz	Two-sided bandwidth; cascaded analog and digital channel filtering
Frequency Error Tolerance	-80		+80	ppm	$P_{RF,iN} = P_{RF,iN,MIN} + 3$ dB

ADF7242

Parameter	Min	Typ	Max	Unit	Test Conditions
RSSI					Measured using IEEE 802.15.4-2006 packet mode
Dynamic range		85		dB	
Accuracy		±3		dB	
Averaging Time		128		µs	
Minimum Sensitivity		-95		dBm	
RECEIVE PATH GFSK MODE					
Sensitivity 1 % PER					
P _{RF,IN,MIN} 2 Mbps		-84.5		dBm	2000 kbps (f _{DEV} = ±500 kHz) GFSK packet mode
P _{RF,IN,MIN} 1 Mbps		-87.5		dBm	1000 kbps (f _{DEV} = ±250 kHz) GFSK packet mode
P _{RF,IN,MIN} 500 kbps		-92		dBm	500 kbps (f _{DEV} = ±250 kHz) GFSK packet mode
P _{RF,IN,MIN} 250 kbps		-92		dBm	250 kbps (f _{DEV} = ±130 kHz) GFSK packet mode
P _{RF,IN,MIN} 125 kbps		-94		dBm	125 kbps (f _{DEV} = ±60 kHz) FSK packet mode
P _{RF,IN,MIN} 100 kbps		-95		dBm	100 kbps (f _{DEV} = ±30 kHz) FSK packet mode
P _{RF,IN,MIN} 62.5 kbps		-96		dBm	62.5 kbps (f _{DEV} = ±60 kHz) FSK packet mode
P _{RF,IN,MIN} 50 kbps		-96		dBm	50 kbps (f _{DEV} = ±30 kHz) FSK packet mode
Sensitivity 0.1% BER					
P _{RF,IN,MIN} 2 Mbps		-87.5		dBm	2000 kbps (f _{DEV} = ±500 kHz) GFSK SPORT mode
P _{RF,IN,MIN} 1 Mbps		-90		dBm	1000 kbps (f _{DEV} = ±250 kHz) GFSK SPORT mode
P _{RF,IN,MIN} 500 kbps		-93		dBm	500 kbps (f _{DEV} = ±250 kHz) GFSK SPORT mode
P _{RF,IN,MIN} 250 kbps		-93		dBm	250 kbps (f _{DEV} = ±130 kHz) GFSK SPORT mode
P _{RF,IN,MIN} 125 kbps		-93		dBm	125 kbps (f _{DEV} = ±60 kHz) FSK SPORT mode
P _{RF,IN,MIN} 62.5 kbps		-96		dBm	62.5 kbps (f _{DEV} = ±60 kHz) FSK SPORT mode
P _{RF,IN,MIN} 50 kbps		-96		dBm	50 kbps (f _{DEV} = ±30 kHz) FSK SPORT mode
Minimum Preamble Length		11		Bytes	2000 kbps (f _{DEV} = ±500 kHz) GFSK packet mode
		9		Bytes	1000 kbps (f _{DEV} = ±250 kHz) GFSK packet mode
		7		Bytes	500 kbps (f _{DEV} = ±250 kHz) GFSK packet mode
		7		Bytes	250 kbps (f _{DEV} = ±130 kHz) GFSK packet mode
		7		Bytes	125 kbps (f _{DEV} = ±60 kHz) FSK packet mode
		7		Bytes	100 kbps (f _{DEV} = ±30 kHz) FSK packet mode
		6		Bytes	62.5 kbps (f _{DEV} = ±60 kHz) FSK packet mode
		6		Bytes	50 kbps (f _{DEV} = ±30 kHz) FSK packet mode
Saturation Level		-15		dBm	All GFSK/FSK modes, packet and SPORT modes, 1% PER and 0.1% BER
CW Blocking Rejection (2000 kbps (f _{DEV} = ±500 kHz) GFSK Packet Mode)					P _{RF,IN} = P _{RF,IN,MIN} , 2 Mbps + 3 dB
±5 MHz		51		dB	
±10 MHz		56		dB	
±20 MHz		56.5		dB	
±30 MHz		60.5		dB	
Modulated Blocking Rejection (2000 kbps (f _{DEV} = ±500 kHz) GFSK Packet Mode)					P _{RF,IN} = P _{RF,IN,MIN} , 2 Mbps + 3 dB
±5 MHz		48		dB	
±10 MHz		53		dB	
±20 MHz		58		dB	
±30 MHz		60		dB	
CW Blocker Rejection (125 kbps (f _{DEV} = ±60 kHz) FSK Packet Mode)					P _{RF,IN} = P _{RF,IN,MIN} , 125 kbps + 3 dB
±2 MHz		54.5		dB	
±5 MHz		62		dB	
±12 MHz		64		dB	
±20 MHz		69		dB	
±32 MHz		70.5		dB	

Parameter	Min	Typ	Max	Unit	Test Conditions
Modulated Blocking Rejection (2000 kbps ($f_{DEV} = \pm 500$ kHz) GFSK Packet Mode)					$P_{RF,IN} = P_{RF,IN,MIN}, 125$ kbps + 3 dB
±2 MHz		52.5		dB	
±5 MHz		60		dB	
±12 MHz		64.5		dB	
±20 MHz		68.5		dB	
±32 MHz		71		dB	
Co-Channel Rejection		-13		dB	2000 kbps ($f_{DEV} = \pm 500$ kHz) GFSK packet mode, $P_{RF,IN} = P_{RF,IN,MIN}, 2$ Mbps + 10 dB, modulated blocker
		-9		dB	250 kbps ($f_{DEV} = \pm 130$ kHz) GFSK packet mode, $P_{RF,IN} = P_{RF,IN,MIN}, 250$ kbps + 10 dB, modulated blocker
Receiver Channel Bandwidth					
Minimum Channel 3 dB Bandwidth					
Analog Filter		1110		kHz	Two-sided bandwidth
Analog and Digital Filter Cascade		520		kHz	Two-sided bandwidth
Maximum Channel 3 dB Bandwidth		2252		kHz	Two-sided bandwidth
Frequency Error Tolerance, 2000 kbps ($f_{DEV} = \pm 500$ kHz) GFSK Packet Mode					
AFC Off		±55		kHz	
AFC On		±165		kHz	AFC pull-in range = ±80 kHz
Frequency Error Tolerance, 500 kbps ($f_{DEV} = \pm 250$ kHz) FSK Packet Mode					
AFC Off		±90		kHz	
AFC On		±190		kHz	AFC pull-in range = ±80 kHz
RSSI, 2000 kbps ($f_{DEV} = \pm 500$ kHz) GFSK Mode					
Accuracy		±3		dBm	
Minimum Sensitivity, Packet Mode		-84.5		dBm	
Minimum Sensitivity, SPORT Mode		-87.5		dBm	SPORT mode with no preamble or SWD detection
RSSI, 500 kbps ($f_{DEV} = \pm 250$ kHz) GFSK Mode					
Accuracy		±3		dBm	
Minimum Sensitivity, Packet Mode		-92		dBm	
Minimum Sensitivity, SPORT Mode		-93		dBm	SPORT mode with no preamble or SWD detection

AUXILIARY SPECIFICATIONS

Table 5.

Parameter	Min	Typ	Max	Unit	Test Conditions
32 kHz RC OSCILLATOR					
Frequency		32.768		kHz	After calibration
Frequency Accuracy		1		%	After calibration at 25°C
Frequency Drift					
Temperature Coefficient		0.14		%/°C	
Voltage Coefficient		4		%/V	
Calibration Time		1		ms	
32 kHz CRYSTAL OSCILLATOR					
Frequency		32.768		kHz	
Maximum ESR		319.8		kΩ	10 pF on XOSC32KP and XOSC32KN
Start-Up Time		2000		ms	12.5pF load capacitors on XOSC32KP and XOSC32KN
WAKE-UP TIMER					
Prescaler Tick Period	0.0305		20,000	ms	
Wake-Up Period	61×10^{-6}		1.31×10^5	sec	

ADF7242

Parameter	Min	Typ	Max	Unit	Test Conditions
TEMPERATURE SENSOR					
Range	-40		+85	°C	Average of 1000 ADC readbacks, after using linear fitting, with correction at known temperature
Resolution		4.7		°C	
Accuracy		±6.4		°C	
BATTERY MONITOR					
Trigger Voltage	1.7		3.6	V	
Trigger Voltage Step Size		62		mV	
Start-Up Time		5		µs	
Current Consumption		30		µA	
EXTERNAL PA INTERFACE					
R _{ON} , PAVSUP_ATB3 to VDD_BAT		5		Ω	extpa_bias_mode = 0, 1, 2, 5, 6
R _{OFF} , PAVSUP_ATB3 to GND		10		MΩ	extpa_bias_mode = 3, 4, power-down
R _{OFF} , PABIASOP_ATB4 to GND		10		MΩ	extpa_bias_mode = 0, power-down
PABIASOP_ATB4 Source Current, Maximum		80		µA	extpa_bias_mode = 1, 3
PABIASOP_ATB4 Sink Current, Minimum		-80		µA	extpa_bias_mode = 2, 4
PABIASOP_ATB4 Current Control Resolution		6		Bits	extpa_bias_mode = 1, 2, 3, 4, 5
PABIASOP_ATB4 Compliance Voltage		150		mV	extpa_bias_mode = 2, 4
PABIASOP_ATB4 Compliance Voltage		3.45		V	extpa_bias_mode = 1, 3
Servo Loop Bias Current		22		mA	extpa_bias_mode = 5, 6
Servo Loop Bias Current Control Step		0.349		mA	extpa_bias_mode = 5, 6

CURRENT CONSUMPTION SPECIFICATIONS

Table 6.

Parameter	Min	Typ	Max	Unit	Test Conditions
CURRENT CONSUMPTION					
TX Mode Current Consumption					
-20 dBm		16.5		mA	IEEE 802.15.4-2006 continuous packet transmission mode
-10 dBm		17.4		mA	IEEE 802.15.4-2006 continuous packet transmission mode
0 dBm		19.6		mA	IEEE 802.15.4-2006 continuous packet transmission mode
+3 dBm		21.5		mA	IEEE 802.15.4-2006 continuous packet transmission mode
+4 dBm		25		mA	IEEE 802.15.4-2006 continuous packet transmission mode
Idle Mode		1.8		mA	XTO26M + digital active
PHY_RDY Mode		10		mA	
RX Mode Current Consumption		19		mA	IEEE 802.15.4-2006 packet mode
MEAS State		3		mA	
SLEEP_BBRAM		0.3		µA	BBRAM contents retained
SLEEP_BBRAM_RCO		1		µA	32 kHz RC oscillator running, some BBRAM contents retained, wake-up time enabled
SLEEP_BBRAM_XTO		1.7		µA	32 kHz crystal oscillator running, some BBRAM contents retained, wake-up time enabled

TIMING AND DIGITAL SPECIFICATIONS

Table 7. Logic Levels

Parameter	Min	Typ	Max	Unit	Test Conditions
LOGIC INPUTS					
Input High Voltage, V_{INH}	$0.7 \times VDD_BAT$			V	
Input Low Voltage, V_{INL}			$0.2 \times V_{DD}$	V	
Input Current, I_{INH}/I_{INL}		± 1		μA	
Input Capacitance, C_{IN}		10		pF	
LOGIC OUTPUTS					
Output High Voltage, V_{OH}	$VDD_BAT - 0.4$			V	$I_{OH} = 500 \mu A$
Output Low Voltage, V_{OL}			0.4	V	$I_{OL} = 500 \mu A$
Output Rise/Fall		5		ns	
Output Load		7		pF	

Table 8. GPIOs

Parameter	Min	Typ	Max	Unit	Test Conditions
GPIO OUTPUTS					
Output Drive Level		5		mA	All GPIOs in logic high state
Output Drive Level		5		mA	All GPIOs in logic low state

Table 9. SPI Interface Timing

Parameter	Min	Typ	Max	Unit	Description
t_1			15	ns	\overline{CS} falling edge to MISO setup time (TRX active)
t_2	40			ns	\overline{CS} to SCLK setup time
t_3	40			ns	SCLK high time
t_4	40			ns	SCLK low time
t_5	80			ns	SCLK period
t_6			10	ns	SCLK falling edge to MISO delay
t_7	5			ns	MOSI to SCLK rising edge setup time
t_8	5			ns	MOSI to SCLK rising edge hold time
t_9	40			ns	SCLK to \overline{CS} hold time
t_{10}	10			ns	\overline{CS} high to SCLK wait time
t_{11}	270			ns	\overline{CS} high time
t_{12}		300	400	μs	\overline{CS} low to MISO high wake-up time, 26 MHz crystal with 10 pF load capacitance, $T_A = 25^\circ C$
t_{13}			20	ns	SCLK rise time
t_{14}			20	ns	SCLK fall time
t_{15}, t_{16}	2			ms	\overline{CS} high time on wake-up after RC_RESET or RC_SLEEP command (see Figure 5 and Figure 70) 26 MHz crystal with 10 pF load

ADF7242

Table 10. IEEE 802.15.4 State Transition Timing

Parameter	Min	Typ	Max	Unit	Test Conditions
Idle to PHY_RDY State		142		µs	
PHY_RDY to Idle State		13.5		µs	
PHY_RDY or TX to RX State (Different Channel)		192		µs	VCO calibration performed
PHY_RDY or RX to TX State (Different Channel)		192		µs	VCO calibration performed
PHY_RDY or TX to RX State (Same Channel)		140		µs	VCO calibration skipped
RX or PHY_RDY to TX State (Same Channel)		140		µs	VCO calibration skipped
RX Channel Change		192		µs	VCO calibration performed
TX Channel Change		192		µs	VCO calibration performed
TX to PHY_RDY State		23		µs	
PHY_RDY to CCA State		192		µs	
CCA to PHY_RDY State		14.5		µs	
RX to Idle State		5.5		µs	
TX to Idle State		30.5		µs	
Idle to MEAS State		19		µs	
MEAS to Idle State		6		µs	
CCA to Idle State		14.5		µs	
RX to CCA State		18		µs	
CCA to RX State		205		µs	

Table 11. GFSK/FSK State Transition Timing

Parameter	Min	Typ	Max	Unit	Test Conditions
Idle to PHY_RDY State		180		µs	
PHY_RDY to Idle State		13.5		µs	
PHY_RDY or TX to RX State (Different Channel)	664			µs	VCO calibration performed
PHY_RDY or RX to TX State (Different Channel)		192		µs	VCO calibration performed
PHY_RDY or RX to TX State (Different Channel)		664		µs	VCO calibration performed, mac_delay_ext ¹ = 472 µs
PHY_RDY or TX to RX State (Same Channel)		612		µs	VCO calibration skipped
RX or PHY_RDY to TX State (Same Channel)		140		µs	VCO calibration skipped
RX or PHY_RDY to TX State (Same Channel)		664		µs	VCO calibration performed, mac_delay_ext ¹ = 472 µs
RX Channel Change		664		µs	VCO calibration performed
TX Channel Change		192		µs	VCO calibration performed
TX Channel Change		664		µs	VCO calibration performed, mac_delay_ext ¹ = 472 µs
TX to PHY_RDY State		23		µs	
PHY_RDY to CCA State		192		µs	
CCA to PHY_RDY State		14.5		µs	
RX to Idle State		18.5		µs	
TX to Idle State		30.5		µs	
Idle to MEAS State		19		µs	
MEAS to Idle State		6		µs	
CCA to Idle State		14.5		µs	
RX to CCA State		18		µs	
CCA to RX State		205		µs	

¹ mac_delay_ext setting applies to both RX and TX states. The default setting is 0 µs.

Table 12. Timing IEEE 802.15.4-2006 SPORT Mode

Parameter	Min	Typ	Max	Unit	Test Conditions/Comments
t ₂₁	18			μs	SFD detect to TRCLK_CLKO_GP3 (data bit clock) active delay
t ₂₂		2		μs	TRCLK_CKO_GP3 bit period
t ₂₃	0.51			μs	DR_GP0 to TRCLK_CKO_GP3 falling edge setup time
t ₂₄		16		μs	TRCLK_CKO_GP3 symbol burst period

Table 13. MAC Timing

Parameter	Min	Typ	Max	Unit	Test Conditions/Comments
t ₂₆		38		μs	Time from frame received to rx_pkt_rcvd interrupt generation
t ₂₇			150	μs	Time allowed, from issuing a RC_TX command, to update Register delaycfg2, Bit mac_delay_ext (0x10B[7:0])
t ₂₈			150	μs	Time allowed, from issuing a RC_TX command, to cancel the RC_TX command
t _{RX_MAC_DELAY}	664	192		μs	IEEE 802.15.4 mode as defined by the standard
				μs	GFSK/FSK mode as required by state transition timing

Table 14. Timing GFSK SPORT Mode

Parameter	Min	Typ	Max	Unit	Test Conditions/Comments
t ₂₉		14		μs	RC_PHY_RDY to TRCLK_CKO_GP3 (data clock) off
t ₃₀	t _{SYM} /2 – 30			ns	DR_GP0 to TRCLK_CKO_GP3 active edge hold time
t ₃₁	t _{SYM} /2 – 30			ns	DR_GP0 to TRCLK_CKO_GP3 active edge setup time
t ₃₂		t _{SYM}			TRCLK_CLKO_GP3 clock period
t ₃₃	20			ns	DT_GP1 to TRCLK_CKO_GP3 sampling edge setup time
t ₃₄	20			ns	DT_GP1 to TRCLK_CKO_GP3 sampling edge hold time
t ₃₅	1.3		6.2	μs	PA nominal power to TRCLK_CKO_GP3 activity/entry into TX state
t ₃₆		14		μs	RC_PHY_RDY to TRCLK_CLKO_GP3 off
t ₃₇		10		μs	RC_PHY_RDY to PA power shutdown
t ₃₈	t _{SYM} /2 – 60		t _{SYM} /2	ns	IRQ2_TRFS_GP2 rising edge to TRCLK_CKO_GP3 active edge delay
t ₃₉	Sync_word_length × t _{SYM}			μs	DR_GP0 activity to end of sync word delay
t ₄₀		5 × t _{SYM}		μs	Sync word detect to IRQ2_TRFS_GP2 high
t ₄₁	Sync_word_length × t _{SYM}			us	TRCLK_CKO_GP3 active to valid data
t ₄₂		105		μs	RC_RX command to TRCLK_CKO_GP3 activity delay (calibrations performed)

TIMING DIAGRAMS

SPI Interface Timing Diagram

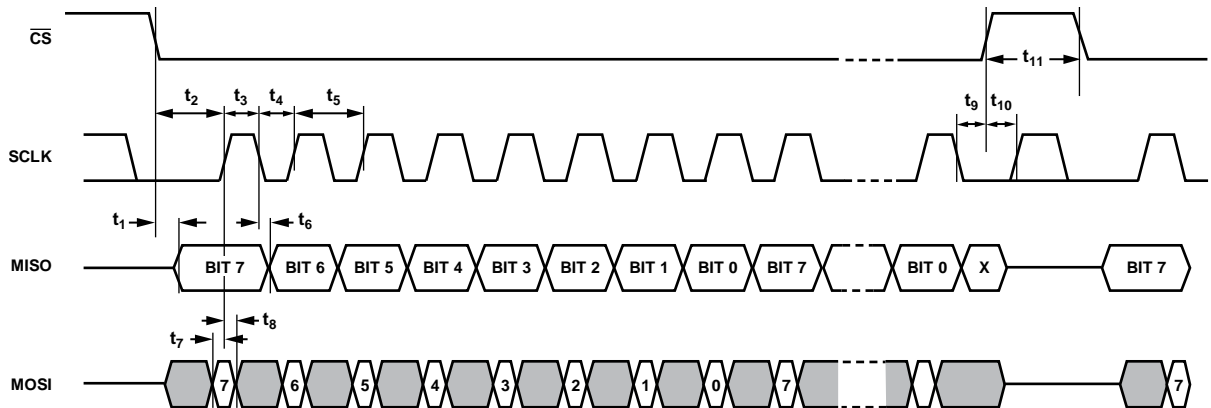

Figure 3. SPI Interface Timing

09812-002

Additional description and timing diagrams are available in the Serial Peripheral interface section.

Sleep-to-Idle SPI Timing

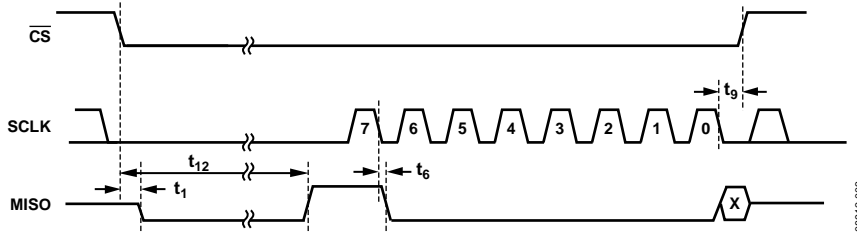

Figure 4. Sleep-to-Idle State Timing

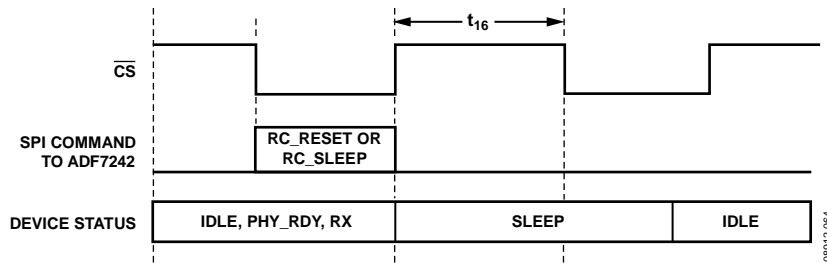

Figure 5. Wake-Up After an RC_RESET or RC_SLEEP Command

MAC Delay Timing Diagram

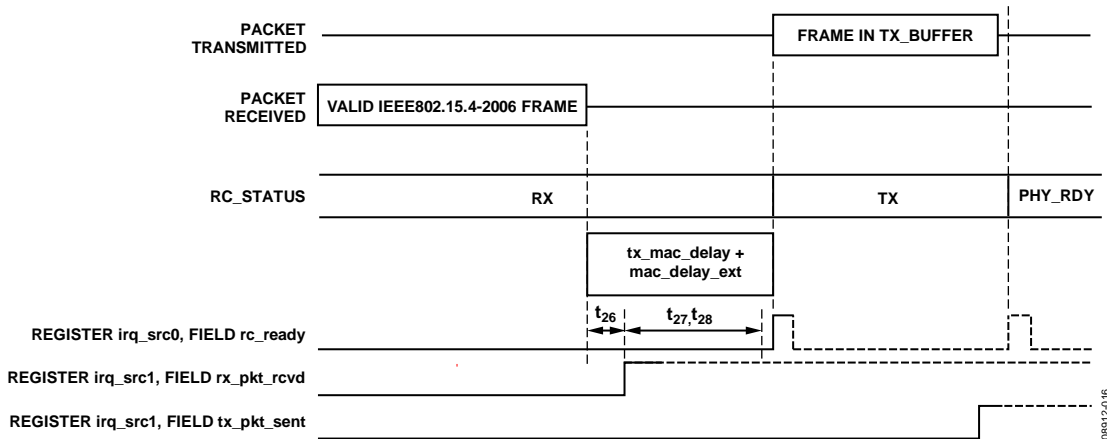

Figure 6. IEEE 802.15.4 MAC Timing

IEEE 802.15.4 RX SPORT Mode Timing Diagrams

Table 15. IEEE 802.15.4 RX SPORT Modes Configurations

Register rc_cfg, Field rc_mode (0x13E[7:0])	Register gp_cfg, Field gpio_config (0x32C[7:0])	Functionality
2	1	Bit clock and data available (see Figure 7)
0	7	Symbol clock and data available (see Figure 8)

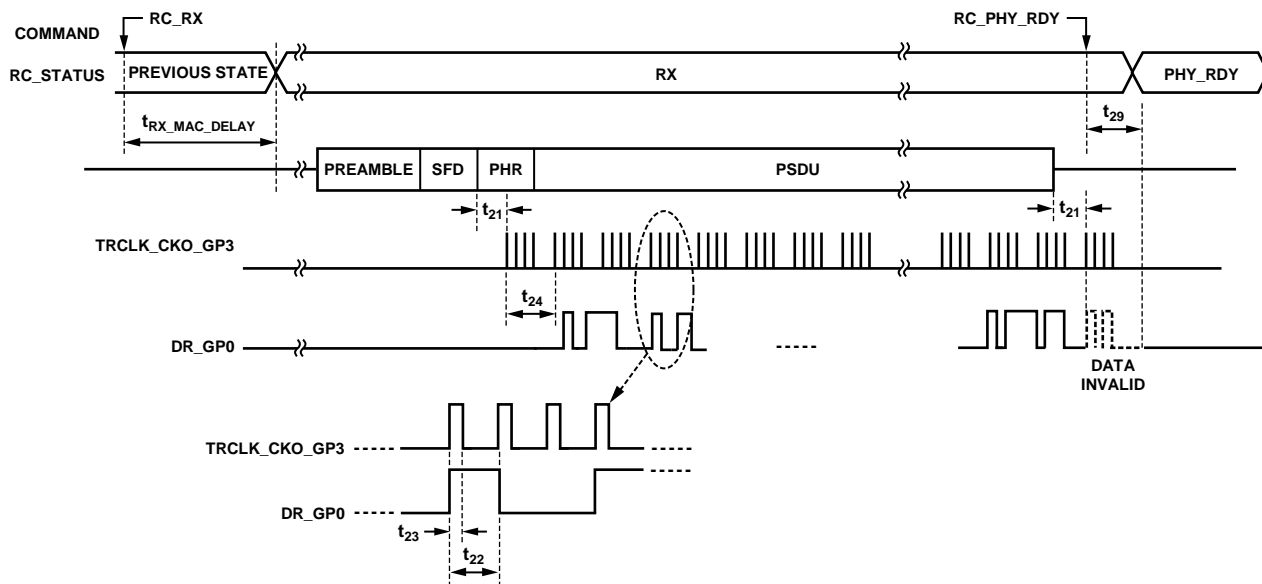

Figure 7. IEEE 802.15.4 RX SPORT Mode: Bit Clock and Data Available

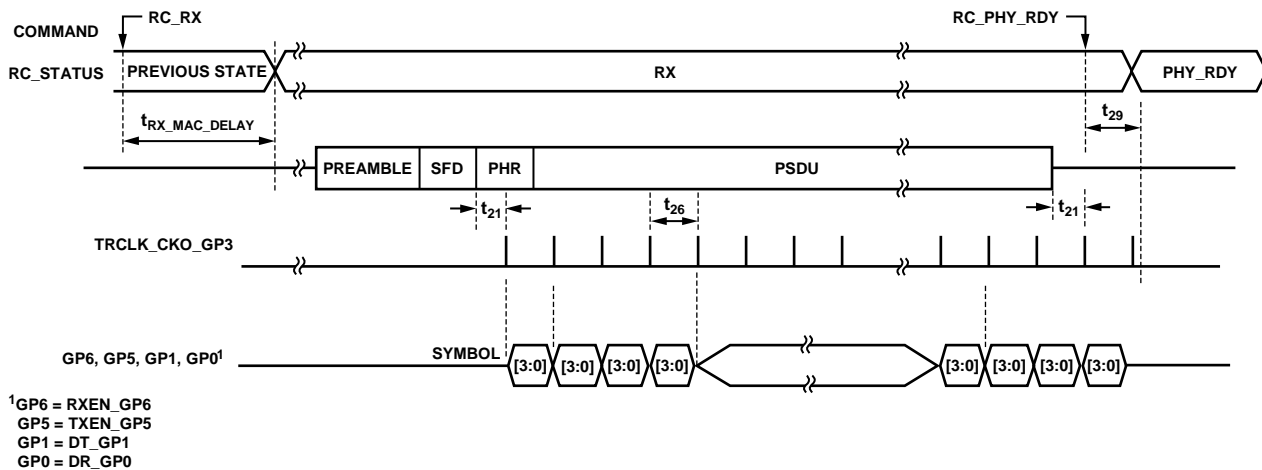

Figure 8. IEEE 802.15.4 RX SPORT Mode: Symbol Clock Output

IEEE 802.15.4 TX SPORT MODE TIMING DIAGRAMS

Table 16. IEEE 802.15.4 TX SPORT Mode Configurations

Register rc_cfg, Field rc_mode (0x13E[7:0])	Register gp_cfg, Field gpio_config (0x32C[7:0])	Functionality
3	1 or 4	Transmission starts after PA ramp up (see Figure 9) gpio_config = 1: data clocked in on rising edge of clock gpio_config = 4: data clocked in on falling edge of clock

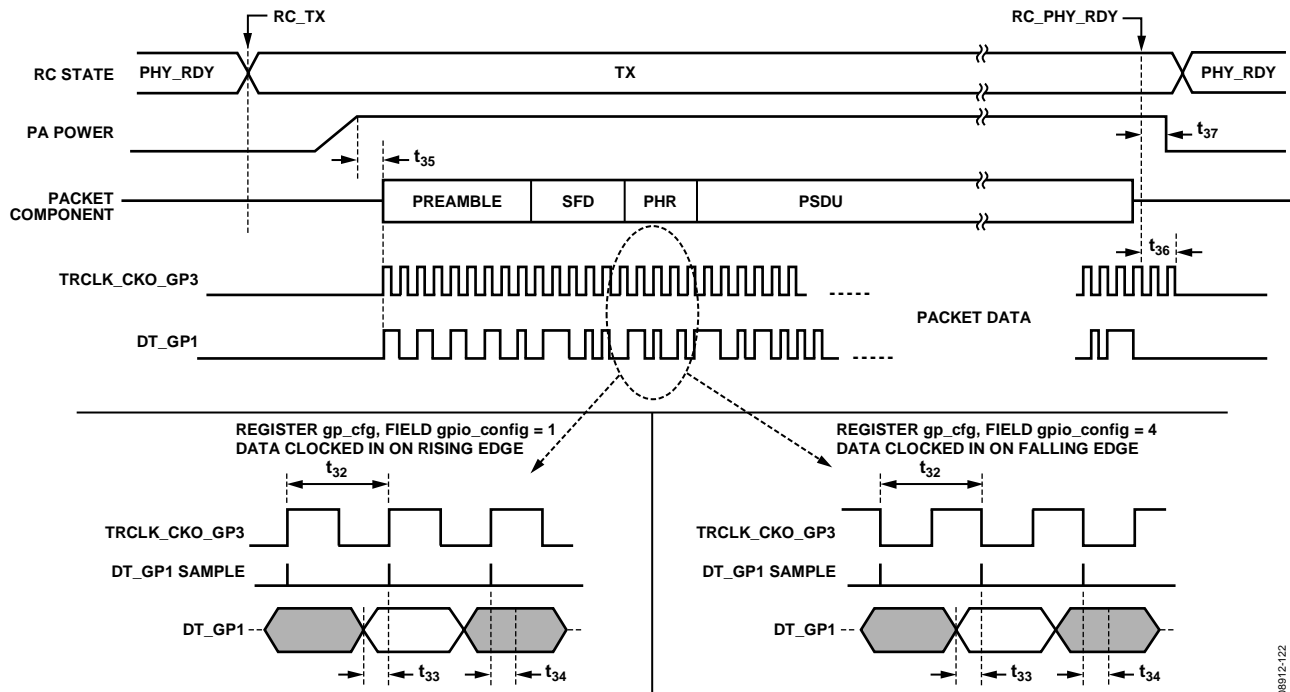

Figure 9. IEEE 802.15.4-2006 TX SPORT Mode

Refer to the SPORT Interface section for further details.

GFSK/FSK RX SPORT MODE TIMING DIAGRAMS

Table 17. GFSK/FSK RX SPORT Mode Configurations

Register rc_cfg, Field rc_mode (0x13E[7:0])	Register gp_cfg, Field gpio_config (0x32C[7:0])	Functionality
3	1 or 4	TRCLK and data pins active in RX, without gating by frame detection (see Figure 10) gpio_config = 1: data clocked out on falling edge/rising edge gpio_config = 4: data clocked out on rising edge/rising edge
3	2 or 5	TRCLK and Data pins activity gated by preamble detection (see Figure 11) gpio_config = 2: data clocked out on falling edge/rising edge gpio_config = 5: data clocked out on rising edge/rising edge
3	3 or 6	TRCLK and data pins activity gated by synchronization word detection (see Figure 12) gpio_config = 3: data clocked out on falling edge/rising edge gpio_config = 6: data clocked out on rising edge/rising edge

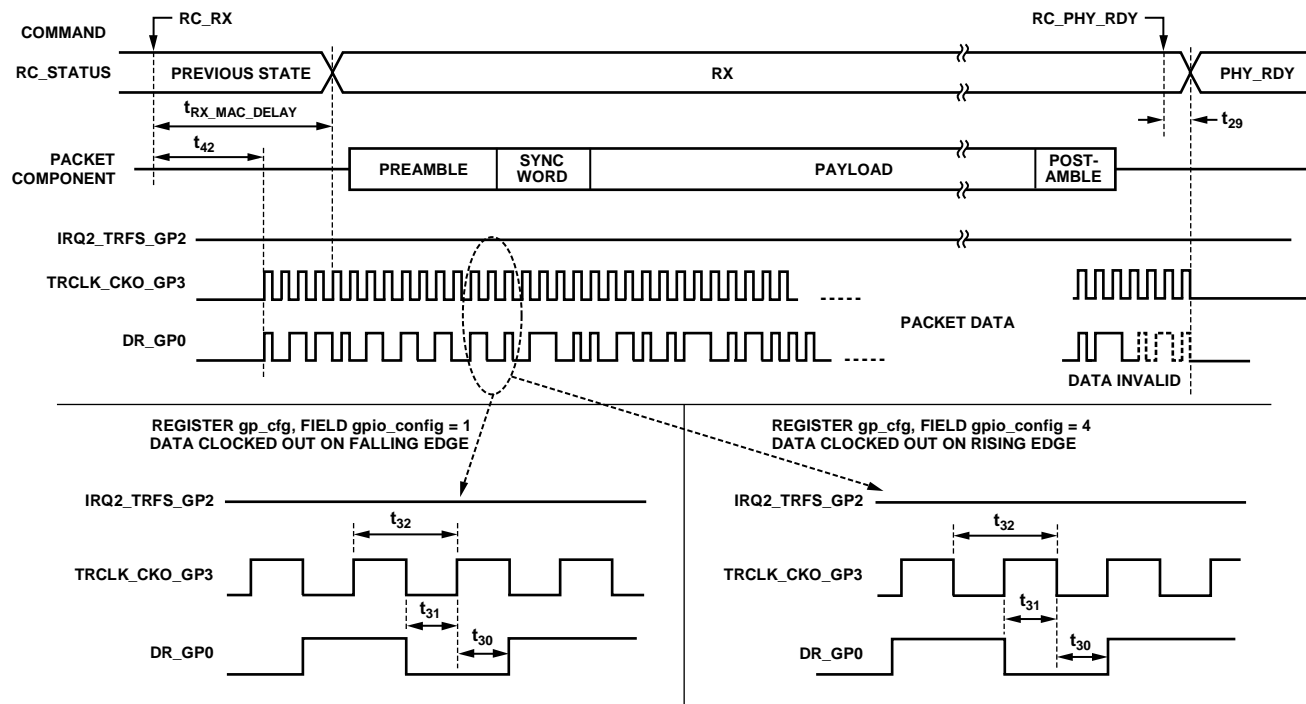

Figure 10. GFSK/FSK RX SPORT Mode: CLK and Data Pins Active in RX, Without Gating by Frame Detection

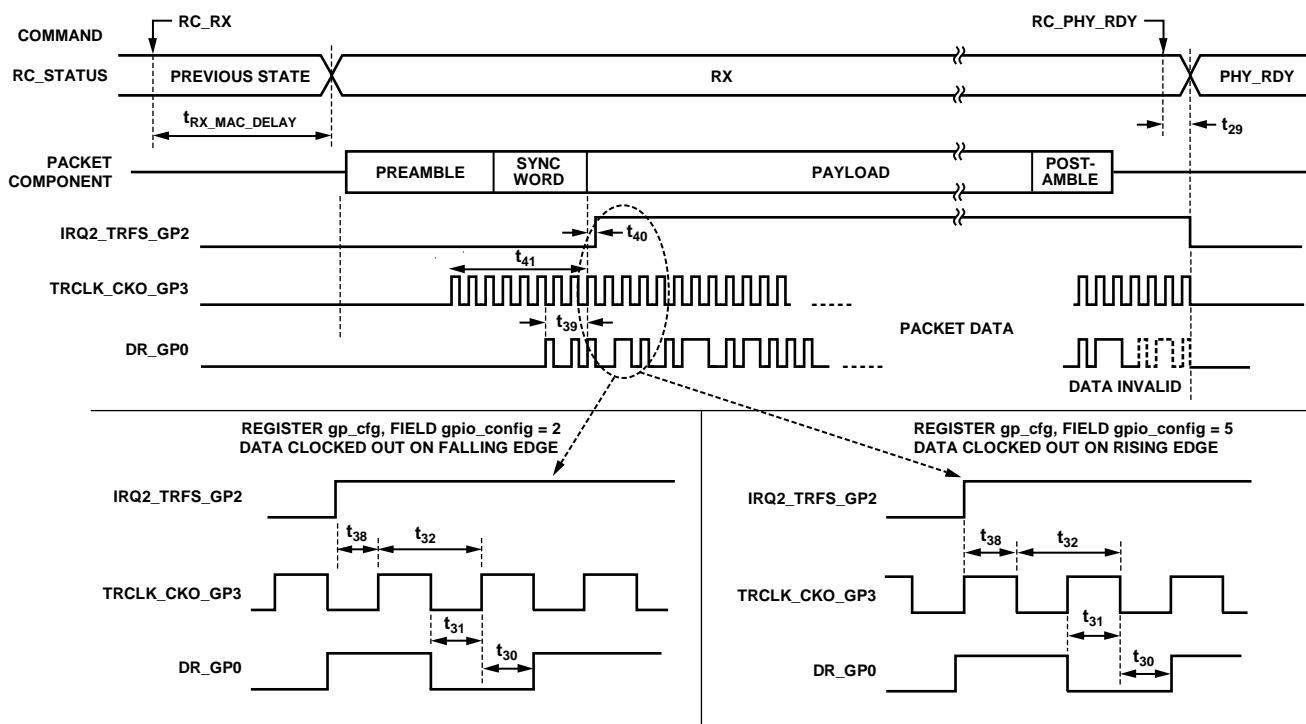

Figure 11. GFSK/FSK RX SPORT Mode: SCLK and Data Pin Activity Gated By Preamble Detection

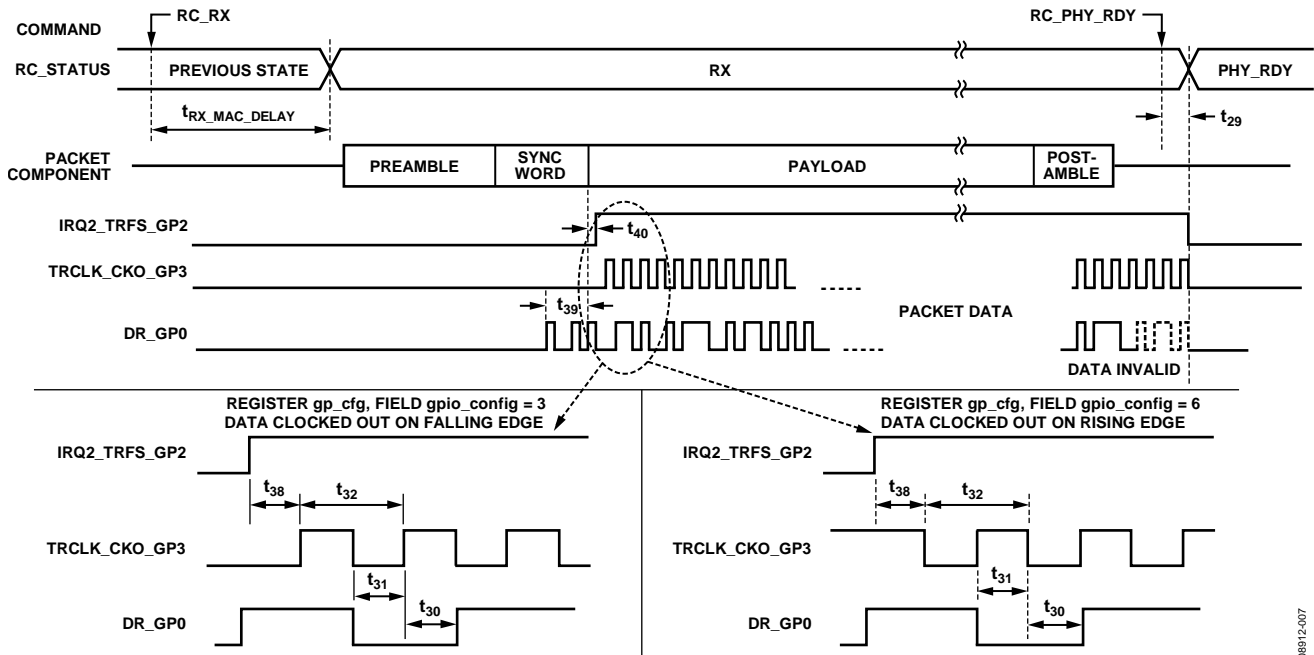

Figure 12. GFSK/FSK RX SPORT Mode: SCLK and Data Pins Activity Gated By Synchronization Word Detection

08912-007

GFSK/FSK TX SPORT Mode Timing Diagrams

Table 18. GFSK/FSK TX SPORT Mode Configurations

Register rc_cfg, Field rc_mode (0x13E[7:0])	Register gp_cfg, Field gpio_config (0x32C[7:0])	Functionality
3	1 or 4	Transmission starts after PA ramp up (see Figure 13) gpio_config = 1: data clocked in on rising edge of clock gpio_config = 4: data clocked in on falling edge of clock

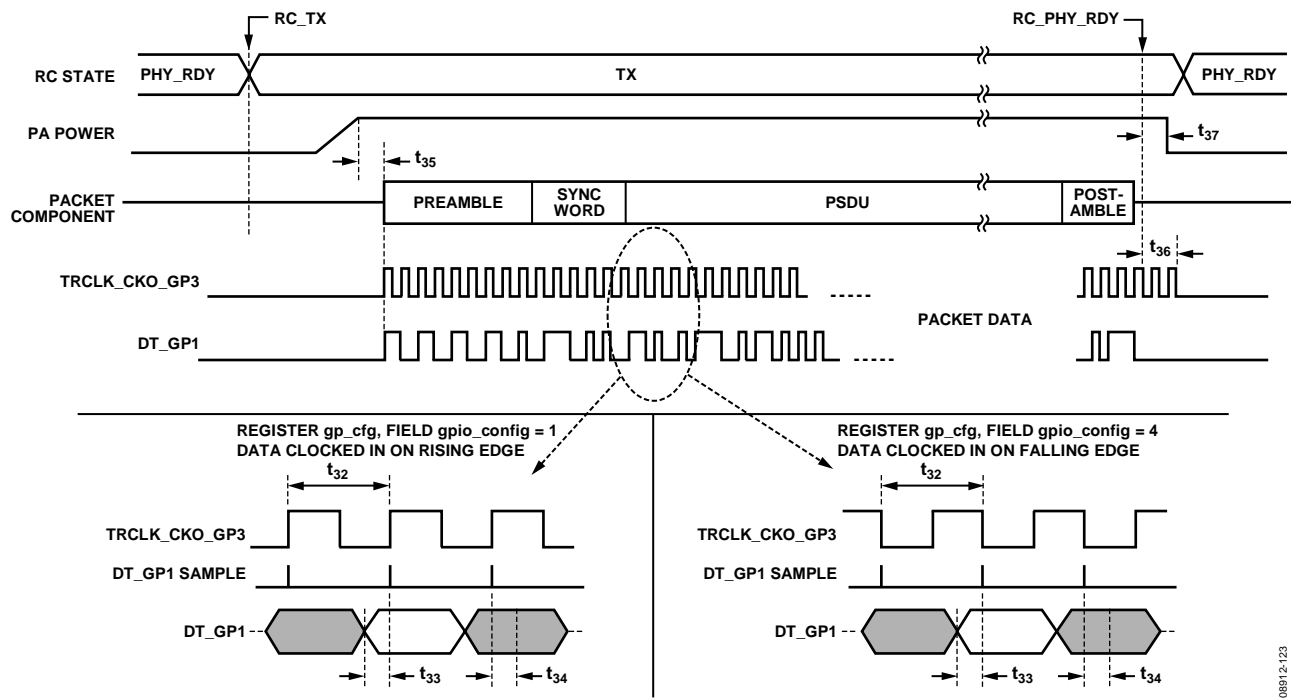

Figure 13. GFSK/FSK TX SPORT Mode

08912-123

Refer to the SPORT Interface section for further details.

ABSOLUTE MAXIMUM RATINGS

T_A = 25°C, unless otherwise noted.

Table 19.

Parameter	Rating
VDD_BAT to GND	-0.3 V to +3.9 V
Operating Temperature Range	
Industrial	-40°C to +85°C
Storage Temperature Range	-65°C to +125°C
Maximum Junction Temperature	150°C
LFCSP θ_{JA} Thermal Impedance	26°C/W
Reflow Soldering	
Peak Temperature	260°C
Time at Peak Temperature	40 sec

Stresses above those listed under Absolute Maximum Ratings may cause permanent damage to the device. This is a stress rating only; functional operation of the device at these or any other conditions above those indicated in the operational section of this specification is not implied. Exposure to absolute maximum rating conditions for extended periods may affect device reliability.

The exposed paddle of the LFCSP package should be connected to ground.

This device is a high performance RF integrated circuit with an ESD rating of <2 kV, and it is ESD sensitive. Proper precautions should be taken for handling and assembly.

ESD CAUTION



ESD (electrostatic discharge) sensitive device. Charged devices and circuit boards can discharge without detection. Although this product features patented or proprietary protection circuitry, damage may occur on devices subjected to high energy ESD. Therefore, proper ESD precautions should be taken to avoid performance degradation or loss of functionality.

PIN CONFIGURATION AND FUNCTION DESCRIPTIONS

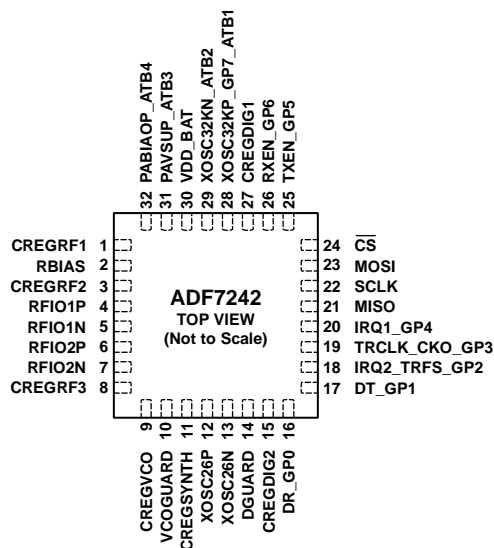

NOTES
 1. THE EXPOSED PADDLE MUST BE CONNECTED TO GROUND.

08912-010

Figure 14. Pin Configuration

Table 20. Pin Function Descriptions

Pin No.	Mnemonic	Description
1	CREGRF1	Regulated Supply Terminal for RF Section. Connect a 220 nF decoupling capacitor from this pin to GND.
2	RBIAS	Bias Resistor 27 kΩ to Ground.
3	CREGRF2	Regulated Supply for RF Section. Connect a 100 pF decoupling capacitor to ground.
4	RFIO1P	Differential RF Input Port 1 (Positive Terminal). A 10 nF coupling capacitor is required.
5	RFIO1N	Differential RF Input Port 1 (Negative Terminal). A 10 nF coupling capacitor is required.
6	RFIO2P	Differential RF Input/Output Port 2 (Positive Terminal). A 10 nF coupling capacitor required.
7	RFIO2N	Differential RF Input/Output Port 2 (Negative Terminal). A 10 nF coupling capacitor required.
8	CREGRF3	Regulated Supply for RF Section. Connect a 100 pF decoupling capacitor from this pin to GND.
9	CREGVCO	Regulated Supply for VCO Section. Connect a 220 nF decoupling capacitor from this pin to GND.
10	VCOGUARD	Guard Trench for VCO Section. Connect to Pin 9 (CREGVCO).
11	CREGSYNTH	Regulated Supply for PLL Section. Connect a 220 nF decoupling capacitor from this pin to GND.
12	XOSC26P	Terminal 1 of External Crystal and Loading Capacitor. This pin is no connect (NC) when an external oscillator is used.
13	XOSC26N	Terminal 2 of External Crystal and Loading Capacitor. Input for external oscillator.
14	DGUARD	Guard Trench for Digital Section. Connect to Pin 15 (CREGDIG2).
15	CREGDIG2	Regulated Supply for Digital Section. Connect a 220 nF decoupling capacitor to ground.
16	DR_GPO	SPORT Receive Data Output/General-Purpose IO Port.
17	DT_GP1	SPORT Transmit Data Input/General-Purpose IO Port.
18	IRQ2_TRFS_GP2	Interrupt Request Output 2/Symbol Clock IEEE 802.15.4-2006 Mode/General-Purpose IO Port.
19	TRCLK_CKO_GP3	SPORT Clock Output/General-Purpose IO Port.
20	IRQ1_GP4	Interrupt Request Output1/General-Purpose IO Port.
21	MISO	SPI Interface Serial Data Output.
22	SCLK	SPI Interface Data Clock Input.
23	MOSI	SPI Interface Serial Data Input.
24	CS	SPI Interface Chip Select Input (and Wake-Up Signal).
25	TXEN_GP5	External PA Enable Signal/General-Purpose IO Port.
26	RXEN_GP6	External LNA Enable Signal/General-Purpose IO Port.
27	CREGDIG1	Regulated Supply for Digital Section. Connect a 1 nF decoupling capacitor from this pin to ground.
28	XOSC32KP_GP7_ATB1	Terminal 1 of 32 kHz Crystal Oscillator/General-Purpose IO Port/Analog Test Bus 1.

ADF7242

Pin No.	Mnemonic	Description
29	XOSC32KN_ATB2	Terminal 2 of 32 kHz Crystal Oscillator/Analog Test Bus 2.
30	VDD_BAT	Unregulated Supply Input from Battery.
31	PAVSUP_ATB3	External PA Supply Terminal/Analog Test Bus 3.
32	PABIAOP_ATB4	External PA Bias Voltage Output/Analog Test Bus 4.
33 (EPAD)	GND	Common Ground Terminal. The exposed paddle must be connected to ground.

TYPICAL PERFORMANCE CHARACTERISTICS

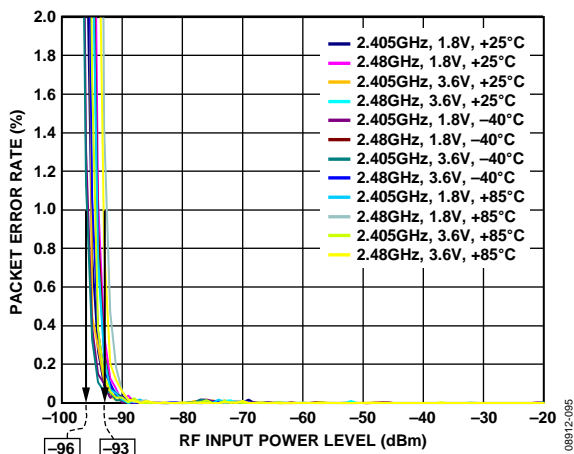

Figure 15. IEEE 802.15.4-2006 Packet Mode Sensitivity vs. Temperature and VDD_BAT, $f_{CHANNEL} = 2.405\text{ GHz}, 2.45\text{ GHz}, 2.48\text{ GHz}, \text{RFIO2}$

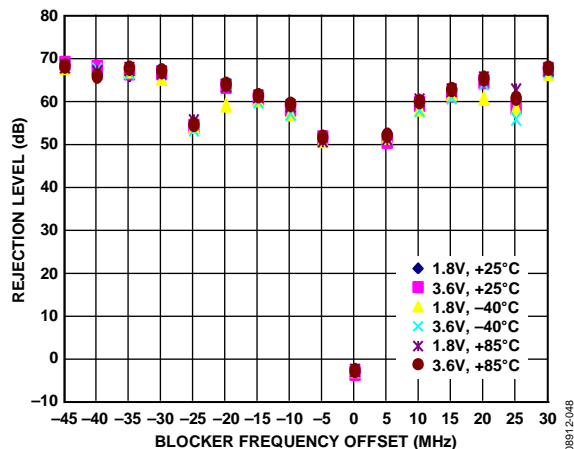

Figure 18. IEEE 802.15.4-2006 Packet Mode Blocker Rejection vs. Temperature and VDD_BAT, Modulated Blocker, $P_{WANTED} = -85\text{ dBm} + 3\text{ dB}$, $f_{CHANNEL} = 2.45\text{ GHz}, \text{RFIO2}$

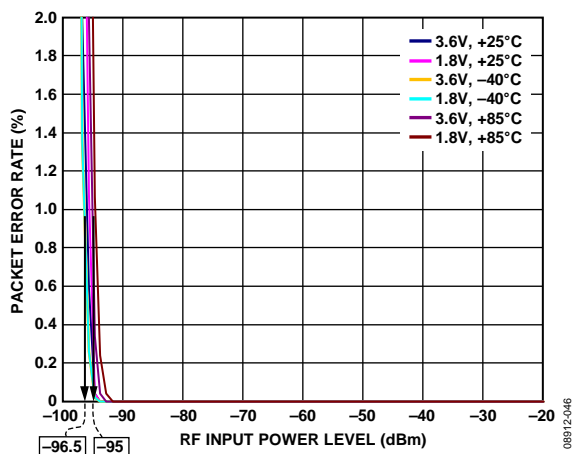

Figure 16. IEEE 802.15.4-2006 Packet Mode PER vs. RF Input Power Level vs. Temperature and VDD_BAT, $f_{CHANNEL} = 2.45\text{ GHz}, \text{RFIO2}$

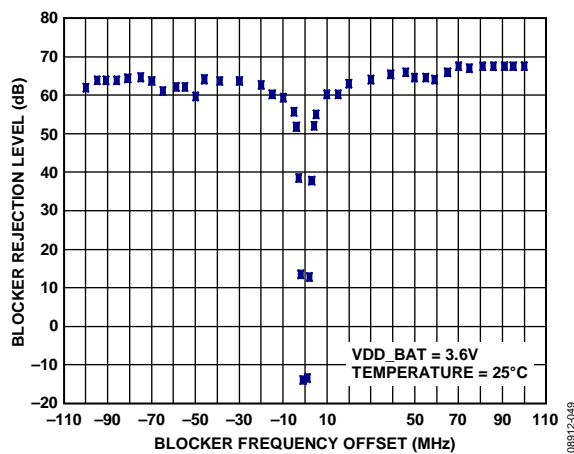

Figure 19. IEEE 802.15.4-2006 Packet Mode Wide-Band Blocker Rejection, CW Blocker, $P_{WANTED} = -95\text{ dBm} + 3\text{ dB}$, $f_{CHANNEL} = 2.45\text{ GHz}, \text{RFIO2}$

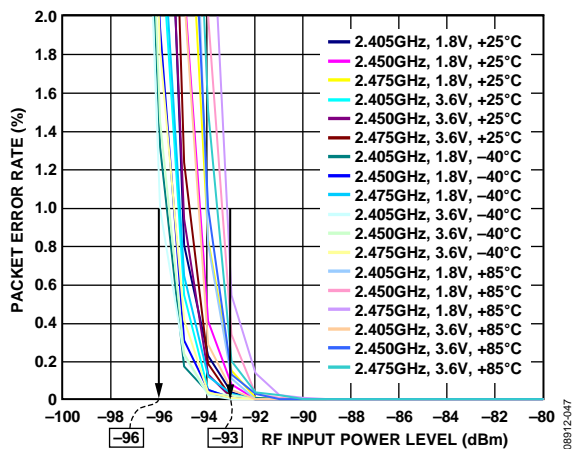

Figure 17. IEEE 802.15.4 Packet Mode Sensitivity vs. Temperature and VDD_BAT, $f_{CHANNEL} = 2.405\text{ GHz}, 2.45\text{ GHz}, 2.475\text{ GHz}, \text{RFIO1}$

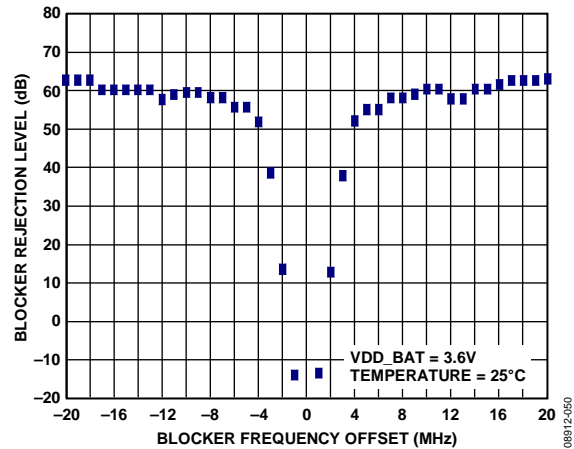

Figure 20. IEEE 802.15.4 Packet Mode Narrow-Band Blocker Rejection, CW Blocker, $P_{WANTED} = -95\text{ dBm} + 3\text{ dB}$, $f_{CHANNEL} = 2.45\text{ GHz}, \text{RFIO2}$

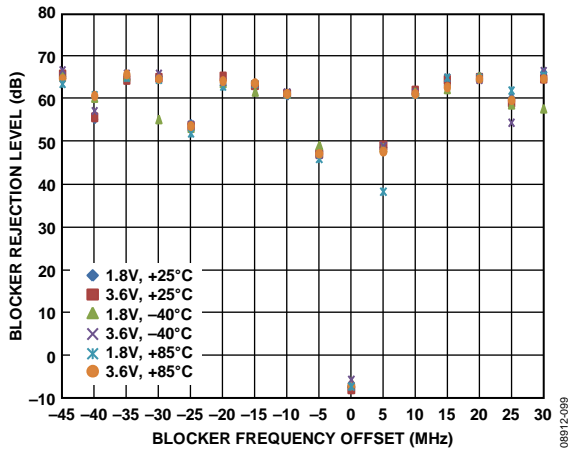

Figure 21. IEEE 802.15.4 Packet Mode Wide-Band Blocker Rejection vs. Temperature and VDD_BAT, Modulated Blocker, $P_{WANTED} = -95 \text{ dBm} + 3 \text{ dB}$, $f_{CHANNEL} = 2.45 \text{ GHz}$, RFIO2

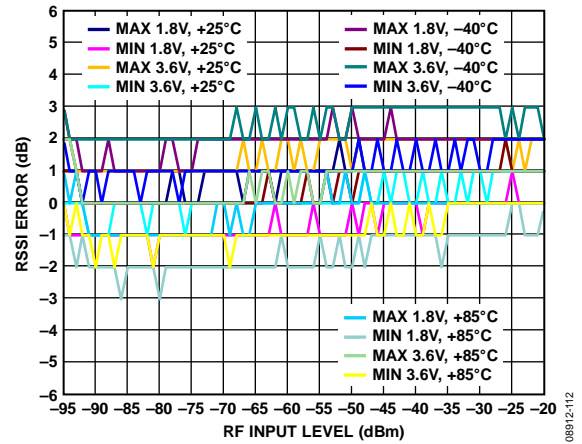

Figure 24. IEEE 802.15.4 Packet Mode RSSI Error vs. RF Input Power Level vs. Temperature and VDD_BAT, $f_{CHANNEL} = 2.45 \text{ GHz}$, RFIO2

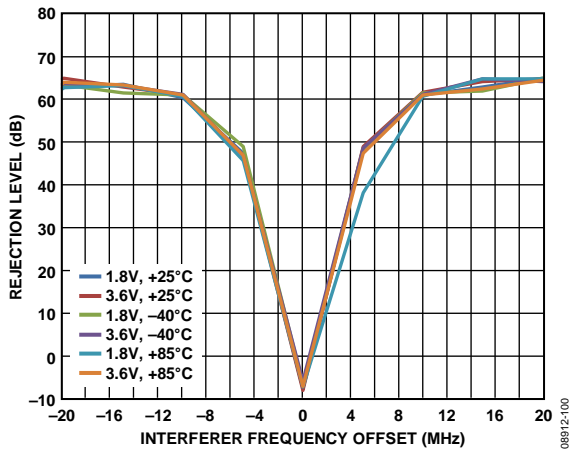

Figure 22. IEEE 802.15.4 Packet Mode Narrow-Band Blocker Rejection vs. Temperature and VDD_BAT, Modulated Blocker, $P_{WANTED} = -95 \text{ dBm} + 3 \text{ dB}$, $f_{CHANNEL} = 2.45 \text{ GHz}$, RFIO2

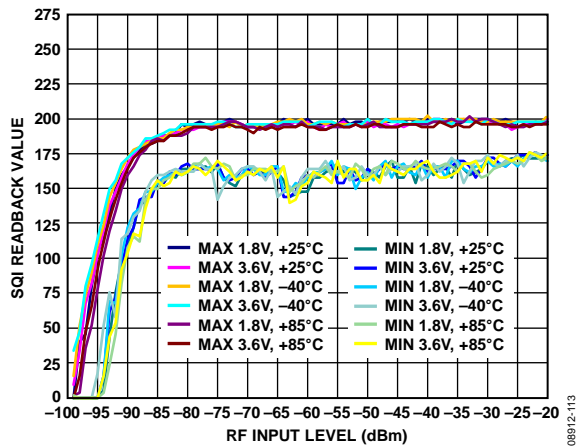

Figure 25. IEEE 802.15.4 Packet Mode SQI vs. RF Input Power Level vs. Temperature and VDD_BAT, $f_{CHANNEL} = 2.45 \text{ GHz}$, RFIO2

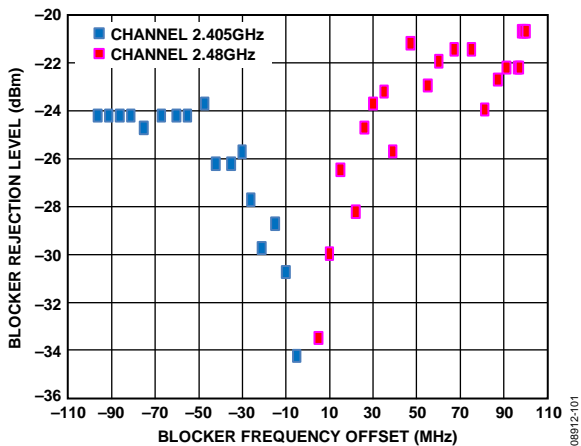

Figure 23. IEEE 802.15.4 Packet Mode Out-of-Band Blocker Rejection, CW Blocker, $P_{WANTED} = -95 \text{ dBm} + 3 \text{ dB}$, $f_{CHANNEL} = 2.405 \text{ GHz}$ and 2.48 GHz , RFIO2, VDD_BAT = 3.6 V, Temperature = 25°C

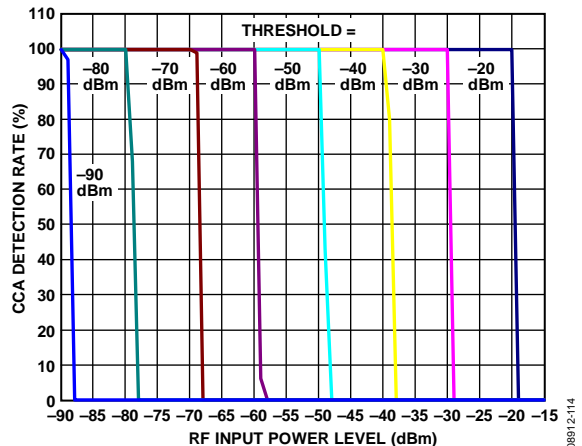

Figure 26. IEEE 802.15.4-2006 CCA Operation vs. RSSI Threshold, $f_{CHANNEL} = 2.45 \text{ GHz}$, VDD_BAT = 3.6 V, Temperature = 25°C, RFIO2 Port

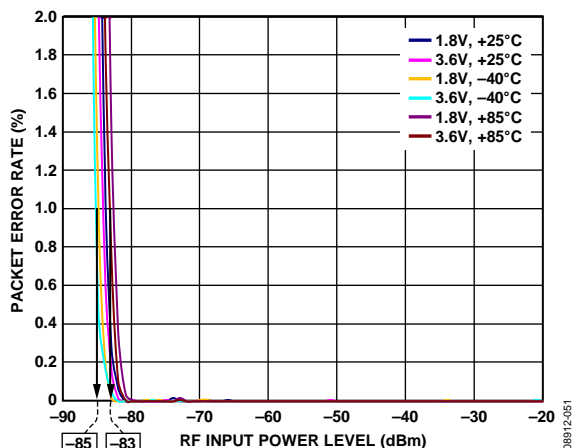

Figure 27. PER vs. RF Input Power Level vs. Temperature and VDD_BAT, 2 Mbps GFSK ($f_{DEV} = \pm 500$ kHz) Mode, $f_{CHANNEL} = 2.45$ GHz, RFIO2

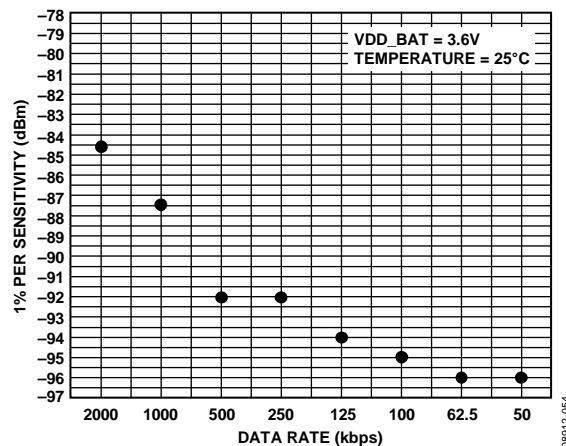

Figure 30. 1% PER sensitivity vs. Data Rate, $f_{CHANNEL} = 2.45$ GHz, RFIO2

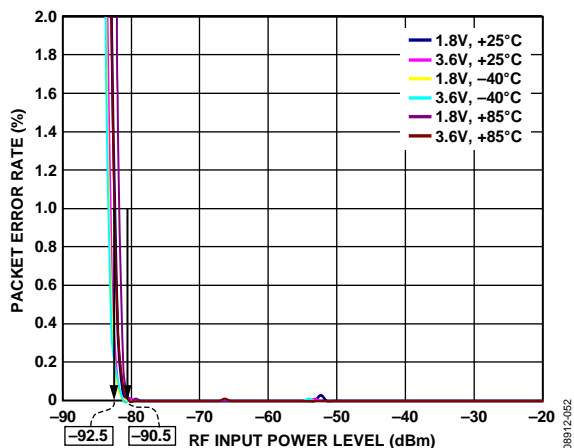

Figure 28. PER vs. RF Input Power Level vs. Temperature and VDD_BAT, 500 kbps GFSK ($f_{DEV} = \pm 250$ kHz) Mode, $f_{CHANNEL} = 2.45$ GHz, RFIO2

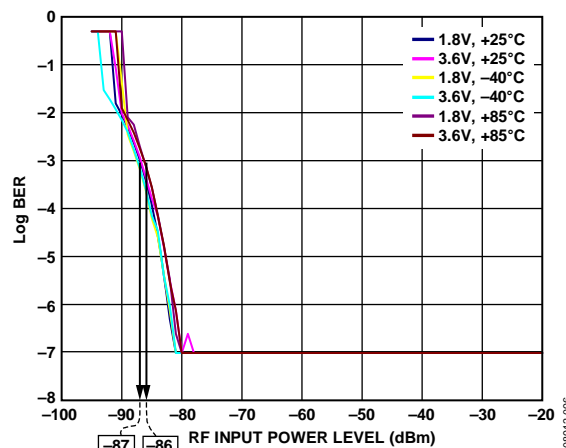

Figure 31. BER vs. RF Input Power Level vs. Temperature and VDD_BAT, 2 Mbps GFSK ($f_{DEV} = \pm 500$ kHz) Mode, $f_{CHANNEL} = 2.45$ GHz, RFIO2

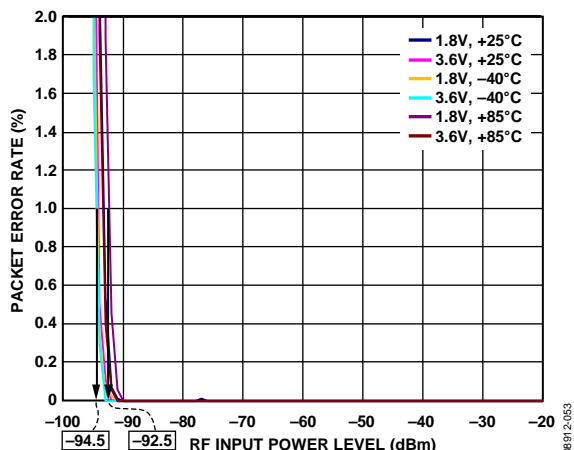

Figure 29. PER vs. RF Input Power Level vs. Temperature and VDD_BAT, 125 kbps FSK ($f_{DEV} = \pm 60$ kHz) Mode, $f_{CHANNEL} = 2.45$ GHz, RFIO2

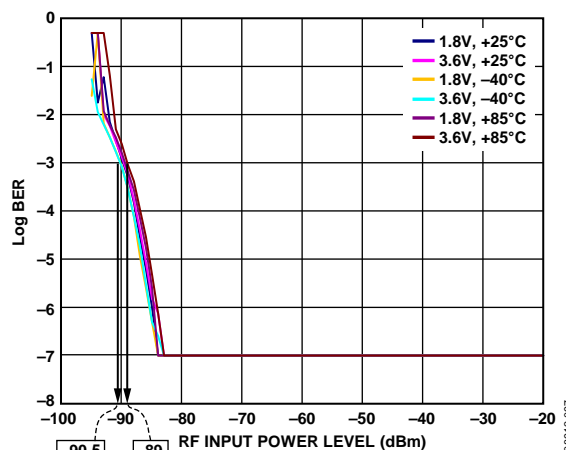

Figure 32. BER vs. RF Input Power Level vs. Temperature and VDD_BAT, 1 Mbps GFSK ($f_{DEV} = \pm 250$ kHz) Mode, $f_{CHANNEL} = 2.45$ GHz, RFIO2

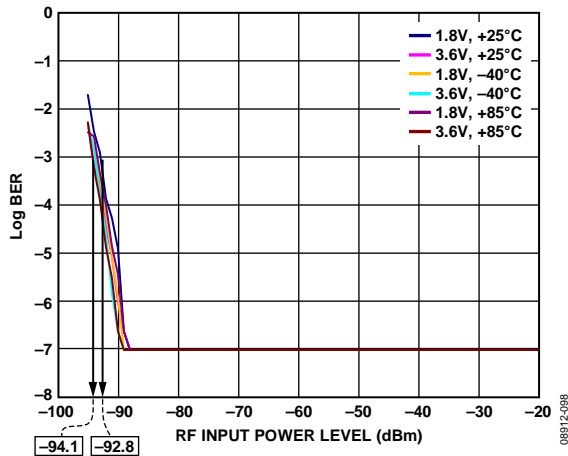

Figure 33. BER vs. RF Input Power Level vs. Temperature and VDD_BAT, 500 kbps GFSK ($f_{DEV} = \pm 250$ kHz) Mode, $f_{CHANNEL} = 2.45$ GHz, RFIO2

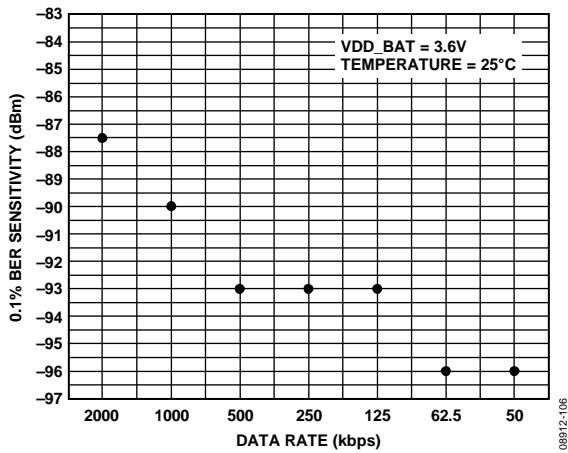

Figure 34. 0.1% BER Sensitivity vs. Data Rate, $f_{CHANNEL} = 2.45$ GHz, RFIO2

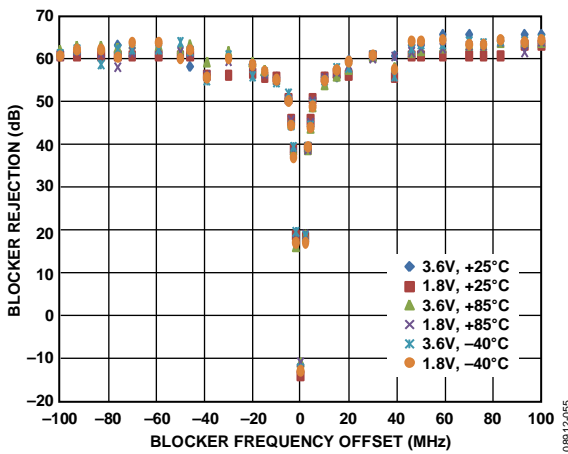

Figure 35. Wideband Blocker Rejection vs. Temperature and VDD_BAT, CW Blocker, 2 Mbps GFSK ($f_{DEV} = \pm 500$ kHz) Packet Mode, $P_{WANTED} = -85$ dBm + 3 dB, $f_{CHANNEL} = 2.45$ GHz, RFIO2

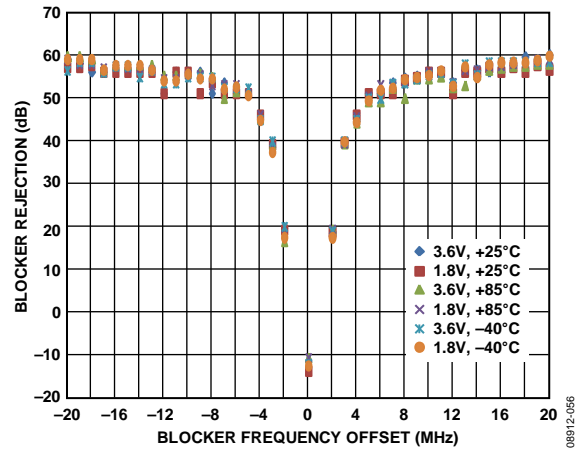

Figure 36. Narrow-Band Blocker Rejection vs. Temperature and VDD_BAT, CW Blocker, 2 Mbps GFSK ($f_{DEV} = \pm 500$ kHz) Packet Mode, $P_{WANTED} = -85$ dBm + 3 dB, $f_{CHANNEL} = 2.45$ GHz, RFIO2

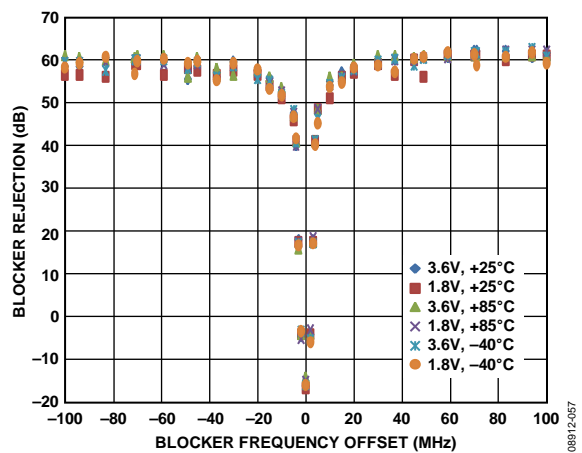

Figure 37. Wideband Blocker Rejection vs. Temperature and VDD_BAT, Modulated Blocker, 2 Mbps GFSK ($f_{DEV} = \pm 500$ kHz) Packet Mode, $P_{WANTED} = -85$ dBm + 3 dB, $f_{CHANNEL} = 2.45$ GHz, RFIO2

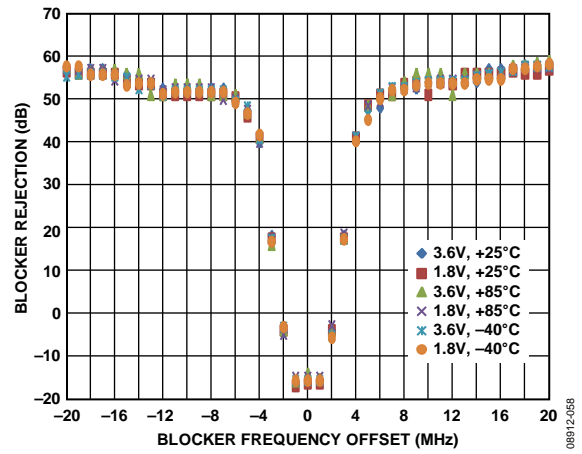

Figure 38. Narrow-Band Blocker Rejection vs. Temperature and VDD_BAT, Modulated Blocker, 2 Mbps GFSK ($f_{DEV} = \pm 500$ kHz) Packet Mode, $P_{WANTED} = -85$ dBm + 3 dB, $f_{CHANNEL} = 2.45$ GHz, RFIO2

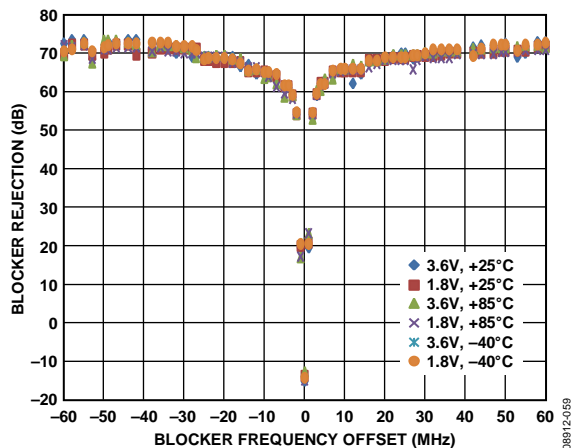

Figure 39. Wideband Blocker Rejection vs. Temperature and VDD_BAT, CW Blocker, 125 kbps FSK ($f_{DEV} = \pm 500$ kHz) Packet Mode, $P_{WANTED} = -94$ dBm + 3 dB, $f_{CHANNEL} = 2.45$ GHz, RFIO2

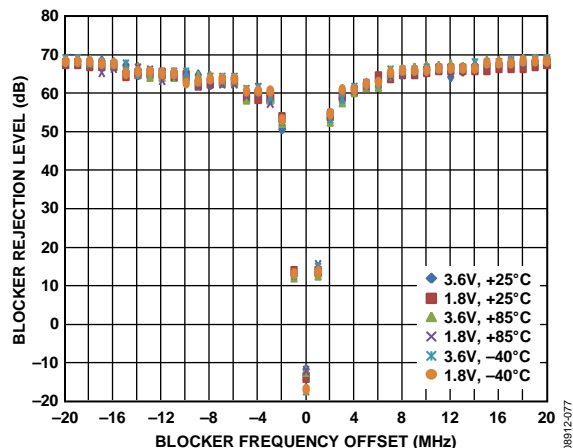

Figure 42. Narrow-Band Blocker Rejection vs. Temperature and VDD_BAT, Modulated Blocker, 125 kbps FSK ($f_{DEV} = \pm 60$ kHz) Packet Mode, $P_{WANTED} = -94$ dBm + 3 dB, $f_{CHANNEL} = 2.45$ GHz, RFIO2

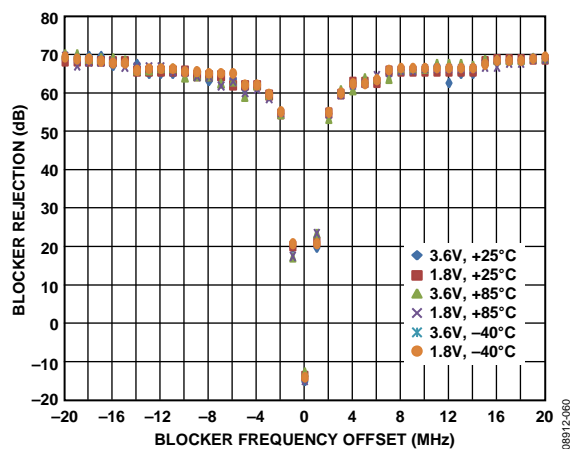

Figure 40. Narrow-Band Blocker Rejection vs. Temperature and VDD_BAT, CW Blocker, 125 kbps FSK ($f_{DEV} = \pm 60$ kHz) Packet Mode, $P_{WANTED} = -94$ dBm + 3 dB, $f_{CHANNEL} = 2.45$ GHz, RFIO2

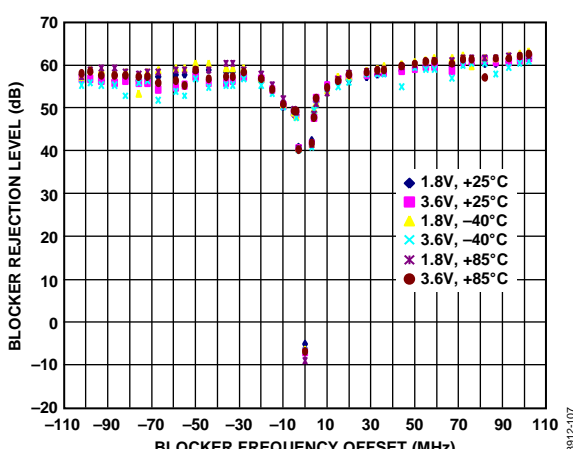

Figure 43. Wideband Blocker Rejection vs. Temperature and VDD_BAT, CW Blocker, 2 Mbps GFSK ($f_{DEV} = \pm 500$ kHz) SPORT Mode, $P_{WANTED} = -87.5$ dBm + 3 dB, $f_{CHANNEL} = 2.45$ GHz, RFIO2

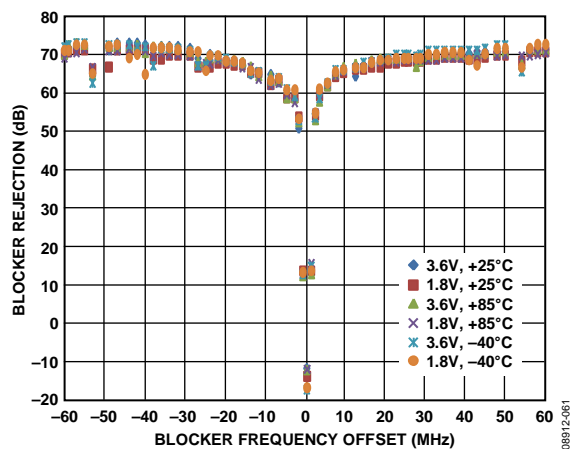

Figure 41. Wideband Blocker Rejection vs. Temperature and VDD_BAT, Modulated Blocker, 125 kbps FSK ($f_{DEV} = \pm 60$ kHz) Packet Mode, $P_{WANTED} = -94$ dBm + 3 dB, $f_{CHANNEL} = 2.45$ GHz, RFIO2

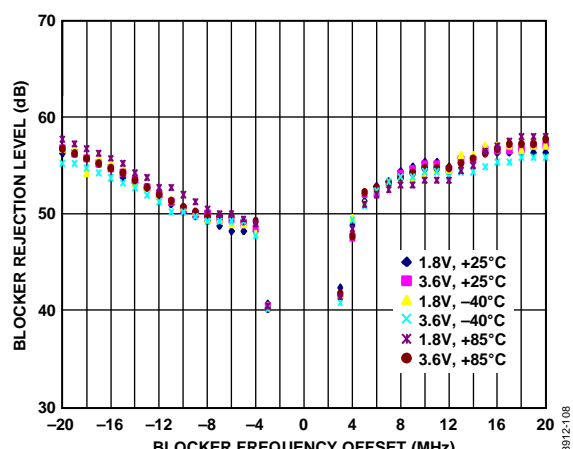

Figure 44. Narrow-Band Blocker Rejection vs. Temperature and VDD_BAT, CW Blocker, 2 Mbps GFSK ($f_{DEV} = \pm 500$ kHz) SPORT Mode, $P_{WANTED} = -87.5$ dBm + 3 dB, $f_{CHANNEL} = 2.45$ GHz, RFIO2

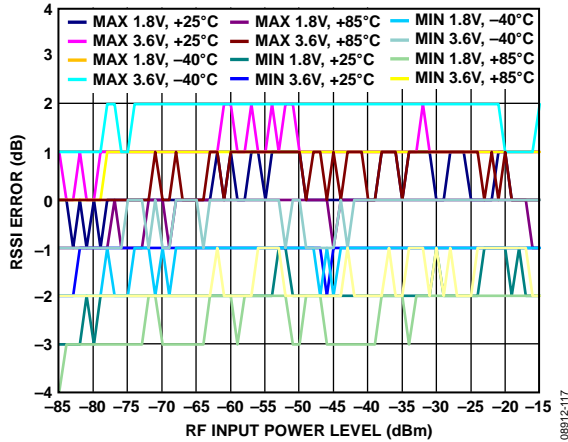

Figure 45. Minimum and Maximum RSSI Error for 1000 Packets vs. RF Input Power Level vs. Temperature and VDD_BAT, 2 Mbps GFSK ($f_{DEV} = \pm 500$ kHz) Packet Mode, $f_{CHANNEL} = 2.45$ GHz, RFIO2

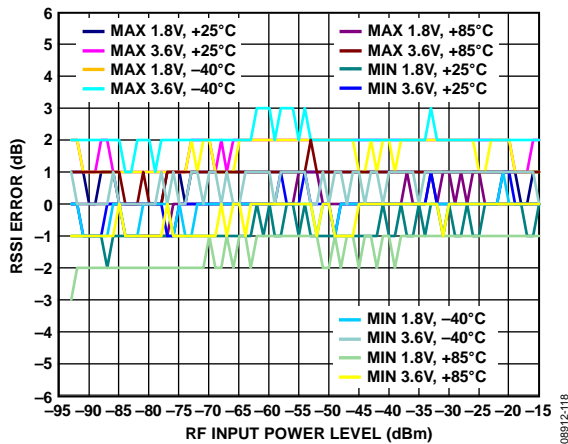

Figure 46. Minimum and Maximum RSSI Error for 1000 Packets vs. RF Input Power Level vs. Temperature and VDD_BAT, 500 kbps FSK ($f_{DEV} = \pm 250$ kHz) Packet Mode, $f_{CHANNEL} = 2.45$ GHz, RFIO2

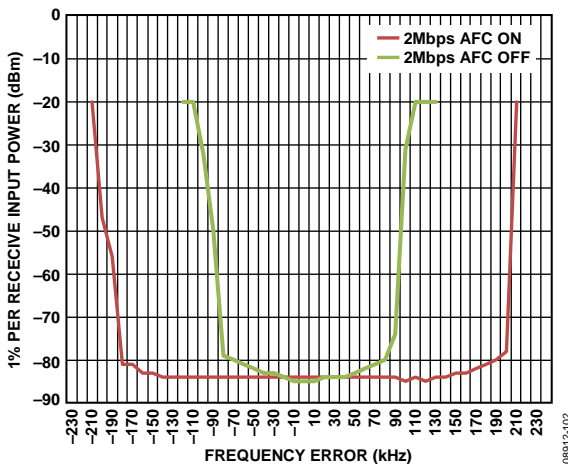

Figure 47. PER vs. Frequency Error with and Without AFC, 2 Mbps GFSK ($f_{DEV} = \pm 500$ kHz) Mode, $f_{CHANNEL} = 2.45$ GHz, RFIO2, VDD_BAT = 3.6 V, Temperature = 25°C

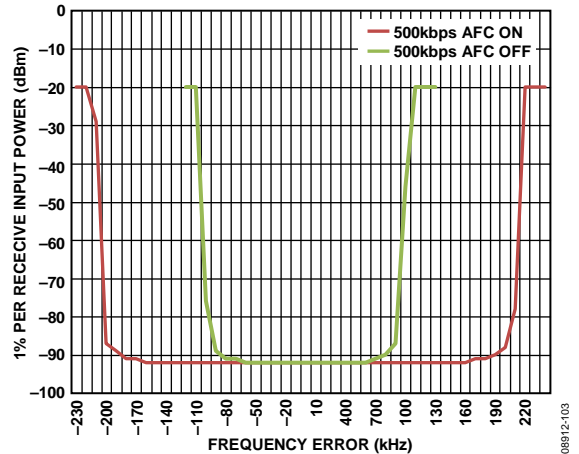

Figure 48. PER vs. Frequency Error with and Without AFC, 500 kbps GFSK ($f_{DEV} = \pm 250$ kHz) Mode, $f_{CHANNEL} = 2.45$ GHz, RFIO2, VDD_BAT = 3.6 V, Temperature = 25°C

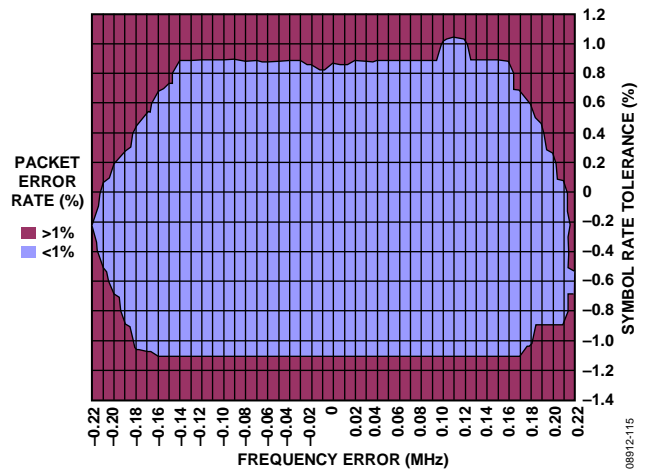

Figure 49. PER vs. Frequency Error vs. Symbol Rate Tolerance, 2 Mbps GFSK ($f_{DEV} = \pm 500$ kHz) Mode, $f_{CHANNEL} = 2.45$ GHz, VDD_BAT = 3.6 V, Temperature = 25°C, RFIO2

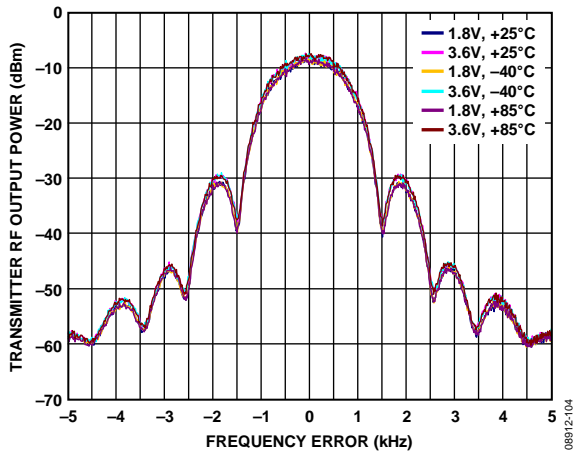

Figure 50. IEEE 802.15.4-2006 Transmitter Spectrum vs. Temperature and VDD_BAT, $f_{CHANNEL} = 2.45$ GHz, Output Power = 3 dBm

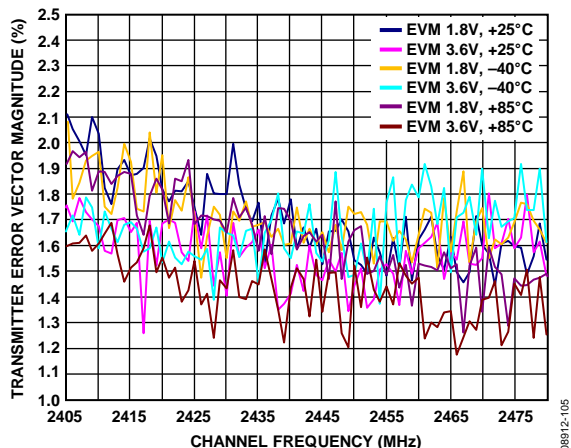

Figure 51. IEEE 802.15.4-2006 Transmitter EVM vs. Temperature and VDD_BAT at All Channels, Output Power = 3 dBm

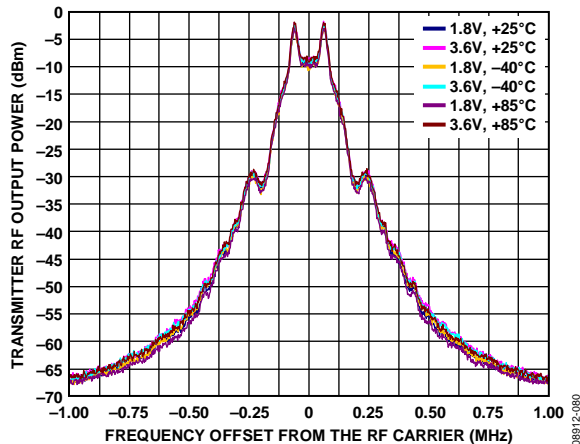

Figure 54. 125 Mbps FSK ($f_{DEV} = \pm 60$ kHz) Mode Transmitter Spectrum vs. Temperature and VDD_BAT, $f_{CHANNEL} = 2.45$ GHz, Output Power = 3 dBm

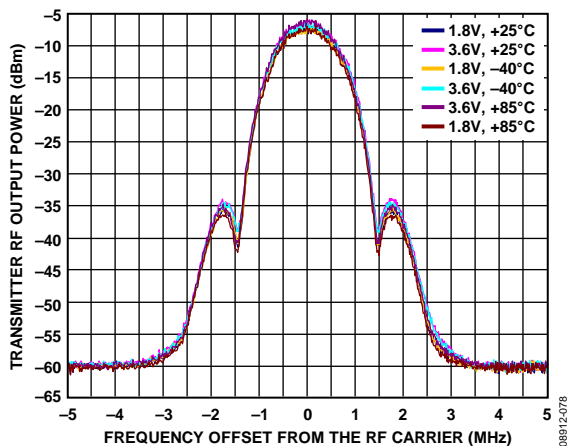

Figure 52. 2 Mbps GFSK ($f_{DEV} = \pm 500$ kHz) Mode Transmitter Spectrum vs. Temperature and VDD_BAT, $f_{CHANNEL} = 2.45$ GHz, Output Power = 3 dBm

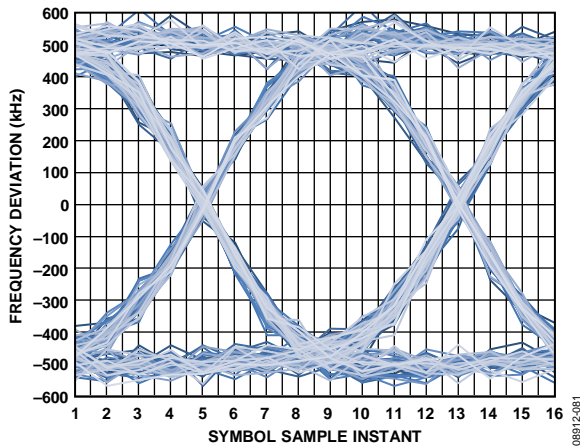

Figure 55. 2 Mbps GFSK ($f_{DEV} = \pm 500$ kHz) Mode Transmitter Eye Diagram, $f_{CHANNEL} = 2.45$ GHz, Output Power = 3 dBm, VDD_BAT = 3.6 V, Temperature = 25°C

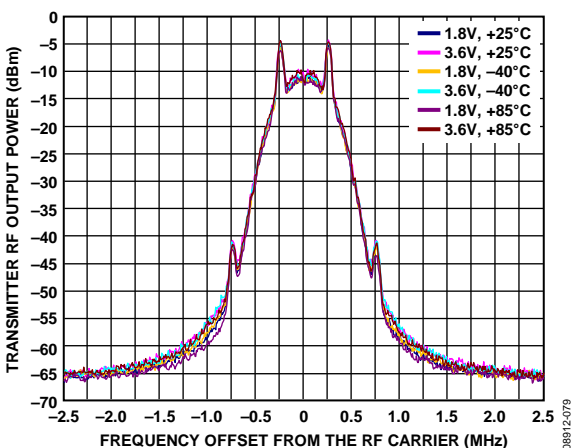

Figure 53. 500 kbps GFSK ($f_{DEV} = \pm 250$ kHz) Mode Transmitter Spectrum vs. Temperature and VDD_BAT, $f_{CHANNEL} = 2.45$ GHz, Output Power = 3 dBm

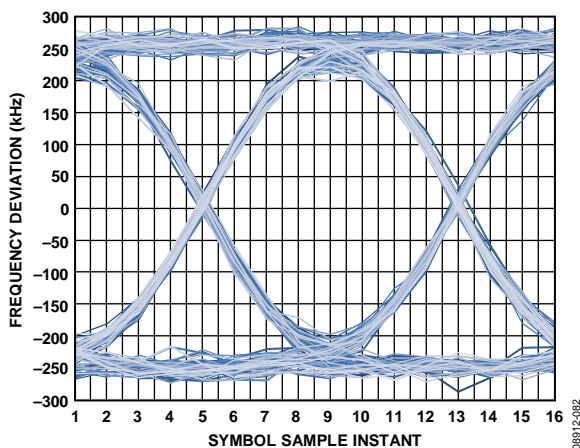

Figure 56. 500 kbps FSK ($f_{DEV} = \pm 250$ kHz) Mode Transmitter Eye Diagram, $f_{CHANNEL} = 2.45$ GHz, Output Power = 3 dBm, VDD_BAT = 3.6 V, Temperature = 25°C

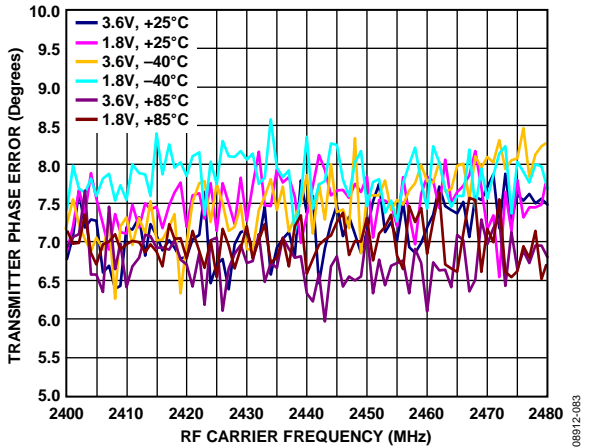

Figure 57. 2 Mbps GFSK ($f_{DEV} = \pm 500$ kHz) Mode Transmitter Phase Error vs. Temperature, VDD_BAT, and Channels, 1 MHz Channel Step, Output Power = 3 dBm

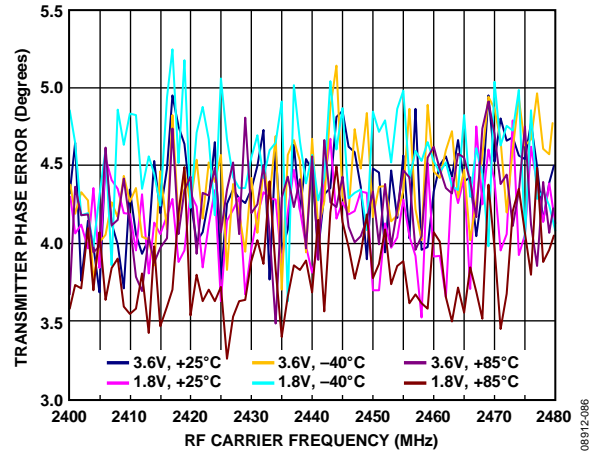

Figure 60. 500 kbps GFSK ($f_{DEV} = \pm 250$ kHz) Mode Transmitter Phase Error vs. Temperature, VDD_BAT, and Channels, 1 MHz Channel Step, Output Power = 3 dBm

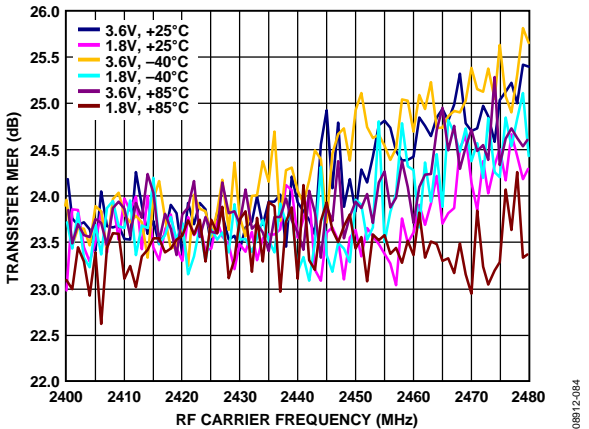

Figure 58. 2 Mbps GFSK ($f_{DEV} = \pm 500$ kHz) Mode Transmitter MER vs. Temperature, VDD_BAT, and Channels, 1 MHz Channel Step, Output Power = 3 dBm

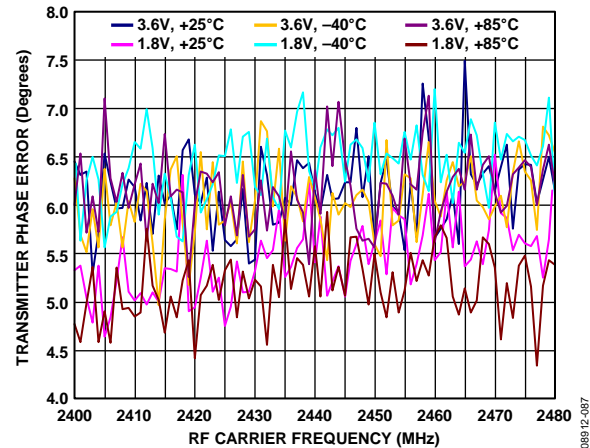

Figure 61. 250 kbps GFSK ($f_{DEV} = \pm 250$ kHz) Mode Transmitter Phase Error vs. Temperature, VDD_BAT, and Channels, 1 MHz Channel Step, Output Power = 3 dBm

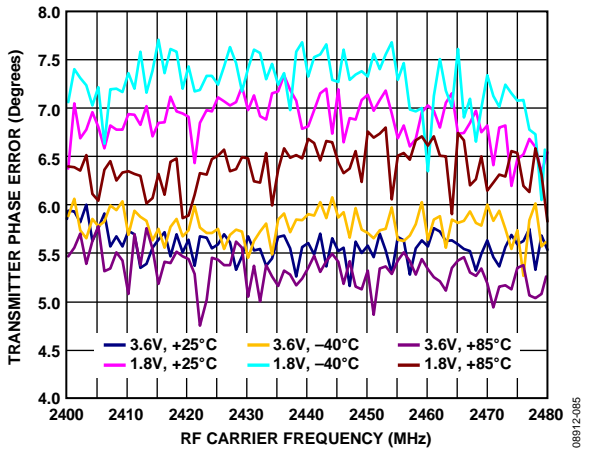

Figure 59. 1 Mbps GFSK ($f_{DEV} = \pm 250$ kHz) Mode Transmitter Phase Error vs. Temperature, VDD_BAT, and Channels, 1 MHz Channel Step, Output Power = 3 dBm

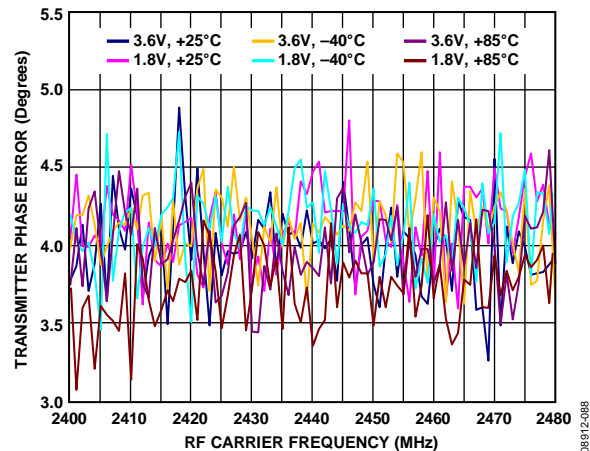

Figure 62. 125 kbps FSK ($f_{DEV} = \pm 60$ kHz) Mode Transmitter Phase Error vs. Temperature, VDD_BAT, and Channels, 1 MHz Channel Step, Output Power = 3 dBm

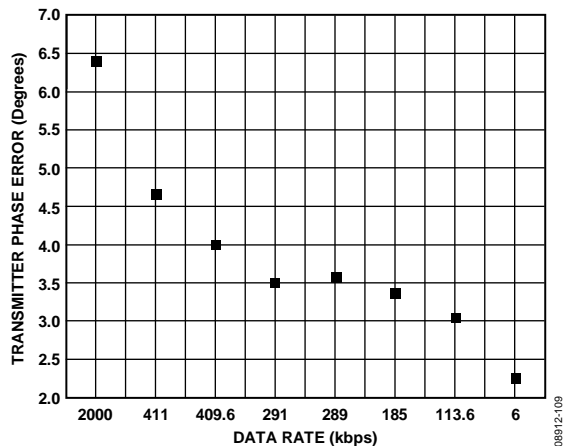

Figure 63. Transmitter Phase Error vs. Data Rate for Each of the Transmitter Bandwidth LUTs, $f_{\text{CHANNEL}} = 2.45 \text{ GHz}$, Output Power = 3 dBm

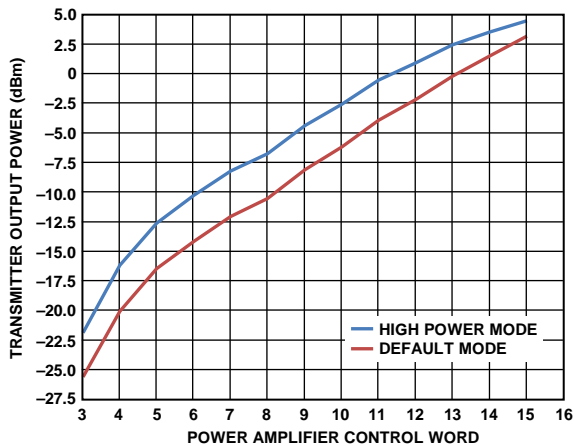

Figure 66. Transmitter Output Power vs. Control Word for Default and High Power Modes, $f_{\text{CHANNEL}} = 2.45 \text{ GHz}$, $V_{\text{DD_BAT}} = 3.6 \text{ V}$, Temperature = 25°C, RF Carrier Frequency, Temperature, and $V_{\text{DD_BAT}}$ (A discrete matching network and a harmonic filter are used as per the ADF7242 reference design.)

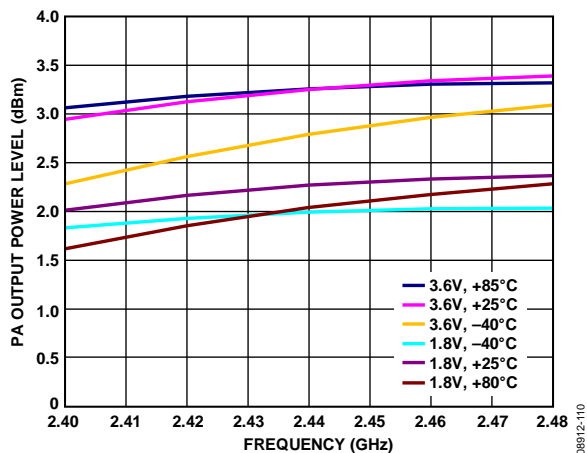

Figure 64. PA Output Power vs. RF Carrier Frequency, Temperature, and $V_{\text{DD_BAT}}$ (A discrete matching network and a harmonic filter are used as per the ADF7242 reference design.)

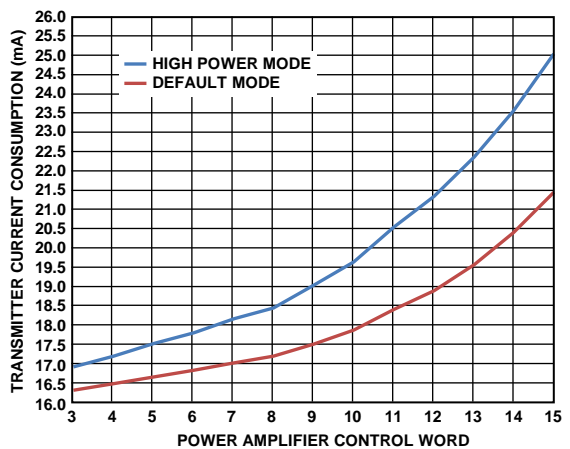

Figure 67. Transmitter Current Consumption vs. Control Word, for Default and High Power Modes, $f_{\text{CHANNEL}} = 2.45 \text{ GHz}$, $V_{\text{DD_BAT}} = 3.6 \text{ V}$, Temperature = 25°C

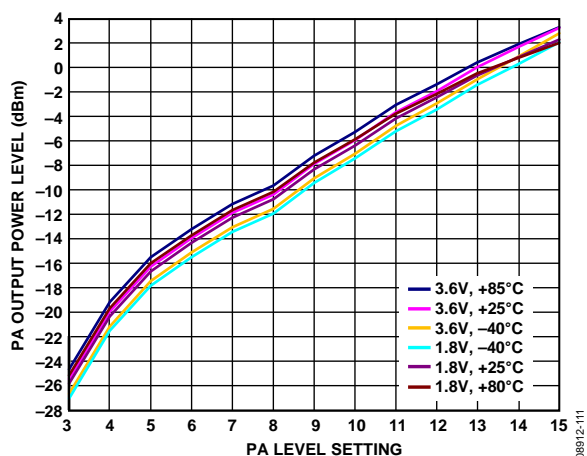

Figure 65. PA Output Power vs. Control Word, Temperature, and $V_{\text{DD_BAT}}$, $f_{\text{CHANNEL}} = 2.44 \text{ GHz}$ (A discrete matching network and a harmonic filter are used as per the ADF7242 reference design.)

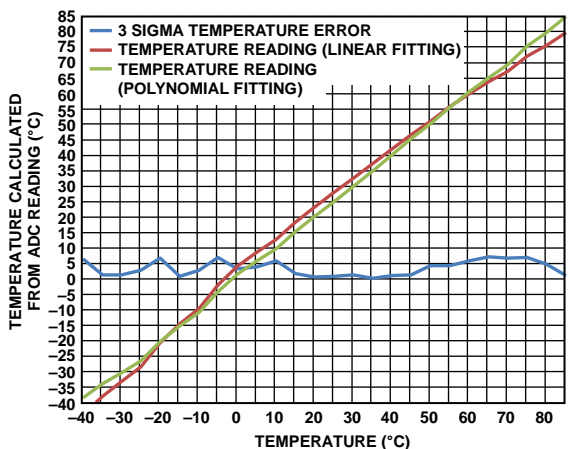

Figure 68. Temperature Sensor Performance (Average of 1000 ADC Readbacks) and 3- Σ Error vs. Temperature, $V_{\text{DD_BAT}} = 3.6 \text{ V}$

TERMINOLOGY

ACK
IEEE 802.15.4-2006 acknowledgment frame

ADC
Analog-to-digital converter

AFC
Automatic frequency correction

AGC
Automatic gain control

Battmon
Battery monitor

CCA
Clear channel assessment

BBRAM
Backup battery random access memory

CRC
Cyclic redundancy check

CSMA/CA
Carrier-sense-multiple-access with collision avoidance

DR
Data rate

DSSS
Direct sequence spread spectrum

FCS
Frame check sequence

FHSS
Frequency hopping spread spectrum

FCF
Frame control field

FSK
Frequency shift keying

GFSK
Gaussian frequency shift keying

LQI
Link quality indicator

MCR
Modem configuration register

MCU
Microcontroller unit

MER
Modulation error ratio

MSK
Minimum shift keying

NC
Not connected

OCL
Offset correction loop

OQPSK
Offset-quadrature phase shift keying

PA
Power amplifier

PHR
PHY header

PHY
Physical layer

POR
Power-on reset

PSDU
PHY service data unit

RC
Radio controller

RCO32K
32 kHz RC oscillator

RSSI
Receive signal strength indicator

RTC
Real-time clock

SFD
Start-of-frame delimiter

SQI
Signal quality indicator

SWD
Sync word detect

VCO
Voltage-controlled oscillator

WUC
Wake-up controller

XTO26M
26 MHz crystal oscillator

XTO32K
32 kHz crystal oscillator

RADIO CONTROLLER

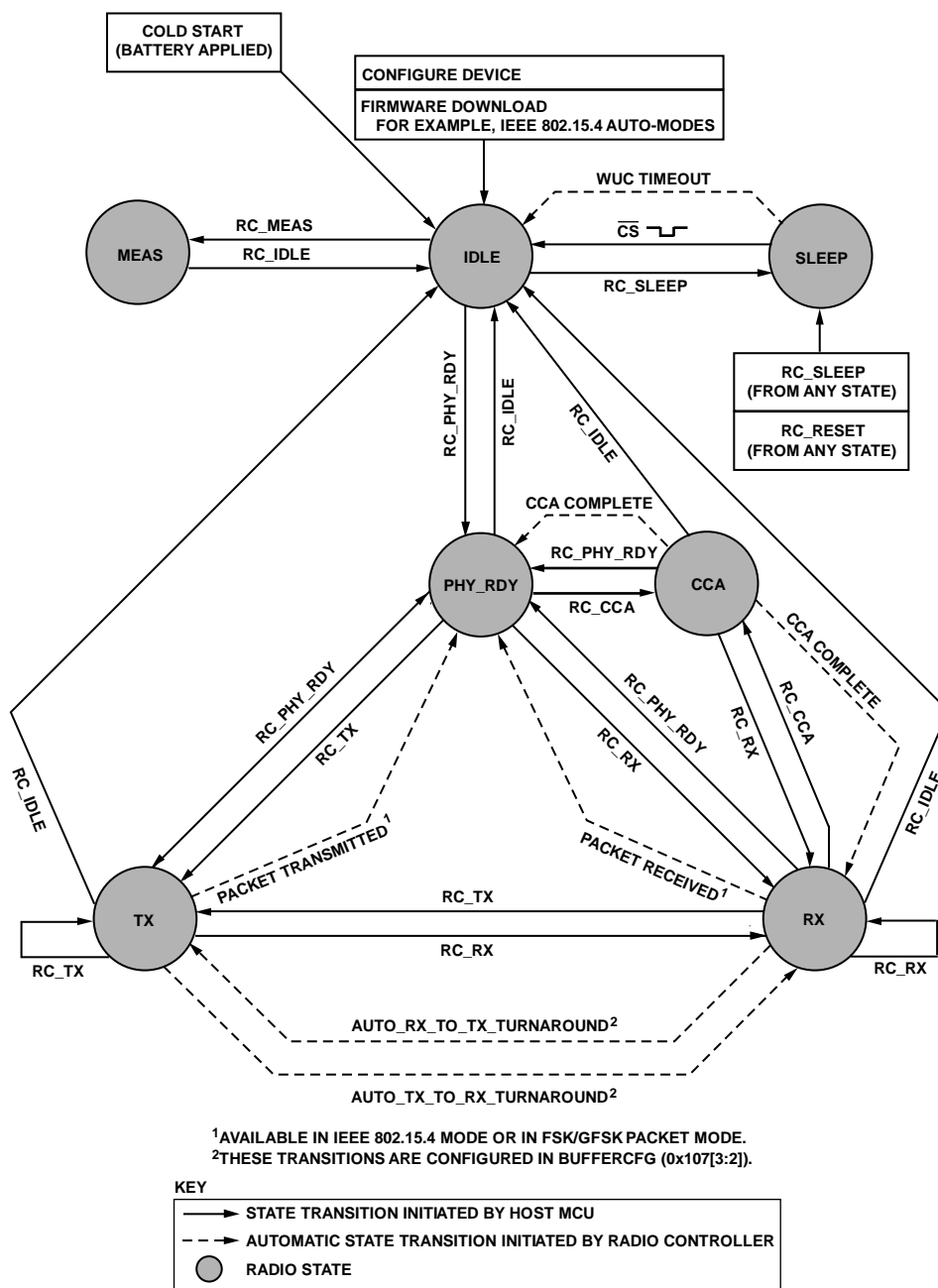

Figure 69. ADF7242 State Diagram

08912-024

ADF7242

The ADF7242 incorporates a radio controller that manages the state of the IC in various operating modes and configurations. The host MCU can use single-byte commands to interface to the radio controller. The function of the radio controller includes the control of the sequence of powering up and powering down various blocks as well as system calibrations in different states of the device. Figure 69 shows the state diagram of the ADF7242 with possible transitions that are initiated by the host MCU and automatically by the radio controller.

Device Initialization

When the battery voltage is first applied to the ADF7242, a cold start-up sequence should be followed, as shown in Figure 70. The start-up sequence is as follows:

- Apply the battery voltage, VDD_BAT, to the device with the desired voltage ramp rate. After a time, t_{RAMP} , VDD_BAT reaches its final voltage value.
- After t_{RAMP} , execute the SPI command, RC_RESET. This command resets and shuts down the device.
- After the specified time, t_{15} , the host MCU can set the \overline{CS} port of the SPI low.
- Wait until the MISO output of the SPI (SPI_READY flag) goes high, at which time the device is in the idle state and ready to accept commands.

A power-on reset takes place when the host MCU sets the \overline{CS} port of the SPI low. All device LDOs are enabled together with the 26 MHz crystal oscillator and the digital core. After the radio controller initializes the configuration registers to their default values, the device enters the idle state.

The cold start-up sequence is needed only when the battery voltage is first applied to the device. Afterwards, a warm start-up sequence can be used where the host MCU can wake up the device from a sleep state by setting the \overline{CS} port of the SPI low.

Idle State

In this state, the receive and transmit blocks are powered down. The digital section is enabled and all configuration registers as well as the packet RAM are accessible. The host MCU has to set any configuration parameters, such as modulation scheme, channel frequency, and WUC configuration in this state.

Bringing the \overline{CS} input low in the sleep state causes a transition into the idle state. The transition from the sleep state to the idle state timing is shown in Figure 4. The idle state can also be entered by issuing an RC_IDLE command in any state other than the sleep state.

PHY_RDY State

Upon entering the PHY_RDY state from the idle state, the RF frequency synthesizer is enabled and a system calibration is carried out. The receive and transmit blocks are not enabled in this state. The system calibration is omitted when the PHY_RDY state is entered from the RX, TX, or CCA state.

The PHY_RDY state can be entered from the idle, RX, TX, or CCA state by issuing an RC_PHY_RDY command.

RX State

The RF frequency synthesizer is automatically calibrated to the programmed channel frequency upon entering the RX state from the PHY_RDY or TX state. The frequency synthesizer calibration can be omitted for single-channel communication systems if short turnaround times are required. Following a programmable MAC delay period, the ADF7242 starts searching for a preamble and a synchronization word if enabled by the user.

The RX state can be entered from the PHY_RDY, CCA, and TX states by issuing an RC_RX command. Depending on whether the device is configured to operate in packet or SPORT mode by setting Register buffercfg, Field rx_buffer_mode, the device can revert automatically to the PHY_RDY state when a packet is received, or remain in the RX state until a command to enter a different state is issued. Refer to the Receiver section for further details.

CCA State

Upon entering the CCA state, a clear channel assessment is performed. The CCA state can be entered from the PHY_RDY or RX state by issuing an RC_CCA command. By default, upon completion of the clear channel assessment, the ADF7242 automatically reverts to the state from which the RC_CCA command originated.

TX State

Upon entering the TX state, the RF frequency synthesizer is automatically calibrated to the programmed channel frequency. The frequency synthesizer calibration can be omitted for communication systems operating on a single channel if short turnaround times are required. Following a programmable delay period, the PA is ramped up and transmission is initiated.

The TX state can be entered from the PHY_RDY or RX state by issuing the RC_TX command. Depending on whether the device is configured to operate in packet or SPORT mode by setting Register buffercfg, Field rx_buffer_mode, the device can revert automatically to the PHY_RDY state when a packet is transmitted, or remain in the TX state until a command to enter a different state is issued. Refer to the Transmitter section for further details.

MEAS State

The MEAS state is used to measure the chip temperature. The transmitter and receiver blocks are not enabled in this state. The chip temperature is measured using the ADC, which can be read from Register adc_rbk, Field adc_out, and is continuously updated with the chip temperature reading.

This state is enabled by issuing the RC_MEAS command from the idle state and can be exited using the RC_IDLE command.

Sleep States

The sleep state is entered with the RC_SLEEP command. The sleep state can be configured to operate in three different modes, which are listed in Table 21.

Table 21. ADF7242 Sleep Modes

Sleep Mode	Active Circuits	Functionality
SLEEP_BBRAM	BBRAM	Packet RAM and modem configuration register (MCR) contents are not maintained. BBRAM retains the IEEE 802.15.4-2006 node addresses ¹ .
SLEEP_BBRAM_XTO	BBRAM and 32 kHz crystal oscillator	32 kHz crystal oscillator is enabled, with data retention in the BBRAM.
SLEEP_BBRAM_RCO	BBRAM and 32 kHz RC Oscillator	32 kHz RC oscillator is enabled, with data retention in the BBRAM.

¹ Refer to the IEEE 802.15.4-2006 Receiver Configuration in Packet Mode section for further details.

SLEEP MODES

The sleep modes are configurable with the wake-up configuration registers, tmr_cfg0 and tmr_cfg1. The contents of Register tmr_cfg0 and Register tmr_cfg1 are reset in the sleep state.

SLEEP_BBRAM

This mode is suitable for applications where the MCU is equipped with its own wake-up timer. SLEEP_BBRAM mode is enabled by setting Register tmr_cfg1, Field sleep_config = 1.

SLEEP_BBRAM_XTO

This mode enables the 32 kHz crystal oscillator and retains certain configuration registers in the BBRAM during the sleep state. To enable SLEEP_BBRAM_XTO mode, set Register tmr_cfg1, Field sleep_config = 5. A wake-up interrupt can be set using, for example, Register irq1_en0, Field wakeup = 1. Refer to the Wake-Up Controller (WUC) section for details on how to configure the ADF7242 WUC.

SLEEP_BBRAM_RCO

This mode enables the 32 kHz RC oscillator and retains certain configuration registers in the BBRAM during the sleep state. This mode can be used when lower timer accuracy is acceptable by the communication system. It is enabled by setting Register tmr_cfg1, Field sleep_config = 11. A wake-up interrupt can be set using, for example, Register irq1_en0, Field wakeup = 1. Refer to the Wake-Up Controller (WUC) section for details on how to configure the ADF7242 WUC.

Wake-Up from the Sleep State

The host MCU can bring \overline{CS} low at any time to wake the ADF7242 from the sleep state. After bringing \overline{CS} low, it must wait until the MISO output (SPI_READY flag) goes high prior to accessing the SPI port. This delay reflects the start-up time of the ADF7242. When the MISO output is high, the voltage regulator of the digital section and the crystal oscillator have stabilized. Unless the chip is in the sleep state, the MISO pin always goes high immediately after bringing \overline{CS} low. The sleep state can also be exited by a timeout event with the WUC configured. Refer to the Wake-Up Controller (WUC) section for details on how to configure the ADF7242 WUC.

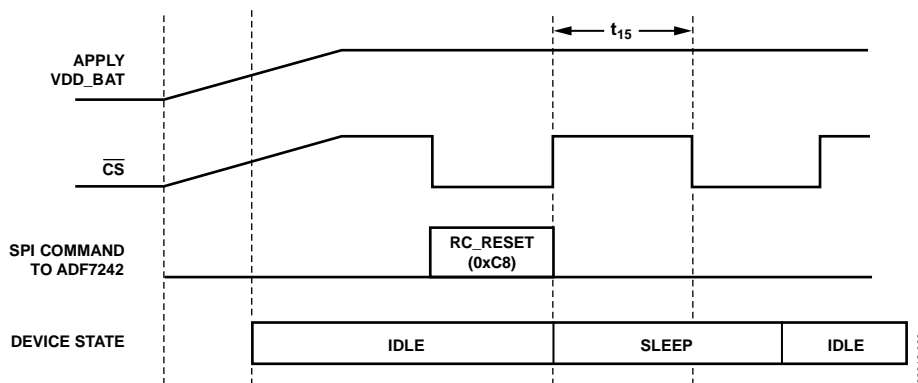

Figure 70. Cold Start Sequence from Application of the Battery

RF FREQUENCY SYNTHESIZER

A fully integrated RF frequency synthesizer is used to generate both the transmit signal and the receive LO signal. The architecture of the frequency synthesizer is shown in Figure 71. The receiver uses the frequency synthesizer circuit to generate the local oscillator (LO) for downconverting an RF signal to the baseband. The transmitter is based on a direct closed-loop VCO modulation scheme using a low noise fractional-N RF frequency synthesizer, where a high resolution Σ - Δ modulator is used to generate the required frequency deviations at the RF in response to the data being transmitted.

The VCO and the frequency synthesizer loop filter of the ADF7242 are fully integrated. To reduce the effect of VCO pulling by the power-up of the power amplifier, as well as to minimize spurious emissions, the VCO operates at twice the RF frequency. The VCO signal is then divided by 2 giving the required frequency for the transmitter and the required LO frequency for the receiver. The frequency synthesizer also features automatic VCO calibration and bandwidth selection.

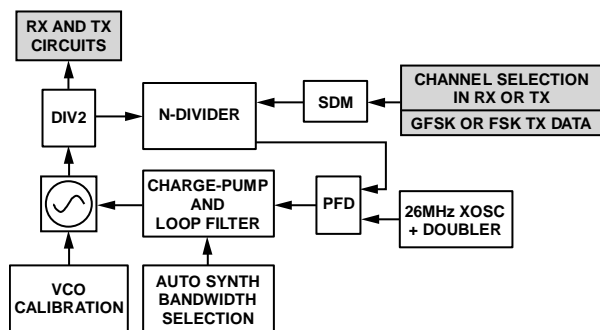

Figure 71. Synthesizer Architecture

RF FREQUENCY SYNTHESIZER CALIBRATION

The ADF7242 requires a system calibration prior to being used in the RX, CCA, or TX state. Because the calibration information is reset when the ADF7242 enters a sleep state, a full system calibration is automatically performed on the transition between the idle and PHY_RDY states. The system calibration is omitted when the PHY_RDY state is entered from the TX, RX, or CCA state.

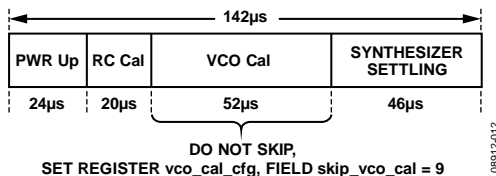

Figure 72. System Calibration Following RC_PHY_RDY

Figure 72 shows a breakdown of the total system calibration time. It comprises a power-up delay, calibration of the receiver baseband filter (RC Cal), and a VCO calibration (VCO Cal). Once the VCO is calibrated, the frequency synthesizer is allowed to settle to within ± 5 ppm of the target frequency. A fully automatic fast VCO frequency and amplitude calibration

scheme is used to mitigate the effect of temperature, supply voltage, and process variations on the VCO performance.

The VCO calibration phase must not be skipped during the system calibration in the PHY_RDY state. Therefore, it is important to ensure that Register `vco_cal_cfg`, Field `skip_vco_cal` = 9 prior to entering the PHY_RDY state from the idle state. This is the default setting and, therefore, only requires programming if skipping of the calibration was previously selected.

The VCO calibration can be skipped on the transition from the PHY_RDY state to the RX, TX, and CCA states on the condition that the calibration has been performed in the PHY_RDY state on the same channel frequency to be used in the RX, TX, and CCA states. The following sequence should be used if skipping the VCO calibration is required in any state following the PHY_RDY state:

- After the system calibration is performed in the PHY_RDY state, the VCO frequency band in Register `vco_band_rb`, Field `vco_band_val_rb` and the VCO bias DAC code in Register `vco_idac_rb`, Field `vco_idac_val_rb` should be read back.
- Before transitioning to any other state and assuming operation on the same channel frequency, the VCO frequency band and amplitude DAC should be overwritten as follows:
 - Set Register `vco_cal_cfg`, Field `skip_vco_cal` = 15 to skip the VCO calibration.
 - Enable the VCO frequency over-write mode by setting Register `vco_ovrw_cfg`, Field `vco_band_ovrw_en` = 1.
 - Write the VCO frequency band read back after the system calibration in the PHY_RDY state to Register `vco_band_ovrw`, Field `vco_band_ovrw_val`.
 - Enable the VCO bias DAC over-write mode by setting Register `vco_ovrw_cfg`, Field `vco_idac_ovrw_en` = 1
 - Write the VCO bias DAC read back after the system calibration in the PHY_RDY state to Register `vco_idac_ovrw`, Field `vco_idac_ovrw_val`.

Following the preceding procedure, the device can transition to other states, which use the same channel frequency without performing a VCO calibration. If it is required to change the channel frequency before entering the RX, TX, or CCA state at any point after the preceding procedure has been used, Register `vco_cal_cfg`, Field `skip_vco_cal` must be set to 9 before transitioning to the respective state. Then the VCO calibration is automatically performed.

RF FREQUENCY SYNTHESIZER BANDWIDTH

The ADF7242 radio controller optimizes the RF frequency synthesizer bandwidth based on whether the device is in the RX or the TX state. If the device is in the RX state, the frequency synthesizer bandwidth is set by the radio controller to ensure optimum blocker rejection. If the device is in the TX state, the radio controller sets the frequency synthesizer bandwidth based

on the required data rate to ensure optimum modulation quality. The frequency synthesizer bandwidth is optimized for the recommended modulation schemes, data rates, and frequency deviations given in Table 22. If the user requires a different modulation scheme or data rate from those listed in Table 22, it is recommended, for optimum device performance, to choose a frequency deviation for the required data rate that gives a modulation index close to those recommended in Table 22.

RF CHANNEL FREQUENCY PROGRAMMING

The frequency of the synthesizer is programmed with the frequency control word, `ch_freq[23:0]`, which extends over Register `ch_freq0`, Register `ch_freq1`, and Register `ch_freq2`. The frequency control word, `ch_freq[23:0]`, contains a binary representation of the absolute frequency of the desired channel divided by 10 kHz.

Writing a new channel frequency value to the frequency control word `ch_freq[23:0]` takes effect after the next frequency synthesizer calibration phase. The frequency synthesizer is calibrated by default during the transition into the `PHY_RDY` from the idle state as well as in the `TX`, `RX` and `CCA` states. Refer to the RF Frequency Synthesizer Calibration, Transmitter, and Receiver sections for further details. To facilitate fast channel frequency changes, a new frequency control word can be written in the `RX` state before a packet has been received. The next `RC_RX` or `RC_TX` command initiates the required frequency synthesizer calibration and settling cycle. Similarly, a new frequency control word can be written after a packet has been transmitted while in the `TX` state and the next `RC_RX` or `RC_TX` command initiates the frequency synthesizer calibration and settling cycle.

REFERENCE CRYSTAL OSCILLATOR

The on-chip crystal oscillator generates the reference frequency for the frequency synthesizer and system timing. The oscillator operates at a frequency of 26 MHz. The crystal oscillator is amplitude controlled to ensure a fast start-up time and stable operation under different operating conditions. The crystal and associated external components should be chosen with care because the accuracy of the crystal oscillator can have a significant impact on the performance of the communication system. Apart from the accuracy and drift specification, it is important to consider the nominal loading capacitance of the crystal. Crystals with a high loading capacitance are less sensitive to frequency pulling due to tolerances of external capacitors and the printed circuit board parasitic capacitances. When selecting a crystal, these advantages should be balanced against the higher current consumption, longer start-up time, and lower trimming range resulting from a larger loading capacitance.

The total loading capacitance must be equal to the specified load capacitance of the crystal and comprises the external parallel loading capacitors, the parasitic capacitances of the `XOSC26P` and `XOSC26N` pins, as well as the parasitic capacitance of tracks on the printed circuit board.

The ADF7242 has an integrated crystal oscillator tuning capacitor that facilitates the compensation of systematic production tolerance and temperature drift. The tuning capacitor is controlled with Register `xto26_trim_cal`, Field `xto26_trim` (0x371). The tuning range provided by the tuning capacitor depends on the loading capacitance of a specific crystal. The total tuning range is typically 25 ppm

TRANSMITTER

TRANSMIT OPERATING MODES

The four primary transmitter operating modes are:

- IEEE 802.15.4-2006 packet mode
- IEEE 802.15.4-2006 SPORT mode
- GFSK/FSK packet mode
- GFSK/FSK SPORT mode

The desired mode of operation is selected via Register `rc_cfg`, Field `rc_mode`. The ADF7242 supports GFSK/FSK modulation with the data rates listed in Table 22. The ADF7242 also fully supports user-defined data rates between 50 kbps and 2 Mbps for FSK mode of operation. The data rate, DR, is set with Register `dr0`, Field `data_rate_high` and Register `dr1`, Field `data_rate_low` according to the following equation:

$$DR = (data_rate_high \times 256 + data_rate_low) \times 100 \text{ bps}$$

The default values of the `dr0` and `dr1` registers configure the device for IEEE 802.15.4-2006 mode.

For GFSK/FSK data rates greater than 250 kbps and IEEE 802.15.4-2006 mode, the modulator preemphasis filter must be enabled with Register `tx_m`, Field `preemp_filt` = 1. The modulator of the ADF7242 has an optional Gaussian symbol filter that can be enabled with Configuration Register `tx_m`, Field `gauss_filt` = 1. The BT product of the Gaussian symbol filter is fixed at 0.5. This can be used for improved spectral efficiency. Gaussian filtering must be disabled for IEEE 802.15.4-2006 mode.

The deviation frequency (f_{DEV}) of the modulator is programmable with Register `tx_fd`, Field `tx_freq_dev` in steps of 10 kHz. Refer to the Device Configuration section for recommended settings for Register `tx_fd`, Field `tx_freq_dev` corresponding with the recommended modulation parameters listed in Table 22. The default value of Register `tx_fd`, Field `tx_freq_dev` configures the correct setting for IEEE 802.15.4-2006 mode. If the user requires a different modulation scheme or data rate from those listed in Table 22, it is recommended, for optimum device performance, to choose a frequency deviation for the required data rate that gives a modulation index close to those recommended in Table 22

Table 22. Recommended Modulation Schemes

Bit rate (kbps)	Modulation Type	Description
250	DSSS-OQPSK	IEEE 802.15.4-2006 compliant
62.5	GFSK/FSK	$f_{DEV} = \pm 60 \text{ kHz}$
125	GFSK/FSK	$f_{DEV} = \pm 60 \text{ kHz}$
250	GFSK/FSK	$f_{DEV} = \pm 130 \text{ kHz}$
500	GFSK/FSK	$f_{DEV} = \pm 250 \text{ kHz}$
1000	GFSK/FSK	$f_{DEV} = \pm 250 \text{ kHz}$
2000	GFSK/FSK	$f_{DEV} = \pm 500 \text{ kHz}$

TRANSMITTER IN IEEE 802.15.4-2006 MODE

IEEE 802.15.4-2006 Transmission

IEEE 802.15.4-2006-compatible mode with packet manager support is selected with Register `rc_cfg`, Field `rc_mode` = 0 (0x13E). In this mode, the ADF7242 packet manager automatically generates the IEEE 802.15.4-2006-compatible preamble and SFD. There is also an option to use a nonstandard SFD by programming Register `sfd_15_4` with the desired alternative SFD. Refer to the IEEE 802.15.4-2006 Programmable SFD subsection of the Receiver in IEEE 802.15.4-2006 Mode section for further details. There are 256 bytes of dedicated RAM (packet RAM), which constitute `TX_BUFFER` and `RX_BUFFER`, available to store transmit and receive packets. The packet header must be the first byte written to `TX_BUFFER`. The address of the first byte of `TX_BUFFER` is stored in Register `txpb`, Field `tx_pkt_base`.

If the automatic FCS field generation has been disabled (Register `pkt_cfg`, Field `auto_fcs_off` = 1), the full frame including FCS must be written to `TX_BUFFER`. In this case, the number of bytes written to `TX_BUFFER` must be equal to the length specified in the PHR field.

If automatic FCS field generation has been enabled (Register `pkt_cfg`, Field `auto_fcs_off` = 0), the FCS is automatically appended to the frame in `TX_BUFFER`. In this case, the number of bytes written to `TX_BUFFER` must be equal to the length specified in the PHR field minus two.

The format of the frame in `TX_BUFFER`, both with automatic FCS field generation enabled and with it disabled, is shown in Figure 73.

Details of how to configure IEEE 802.15.4-2006 TX SPORT mode are given in the SPORT Interface section.

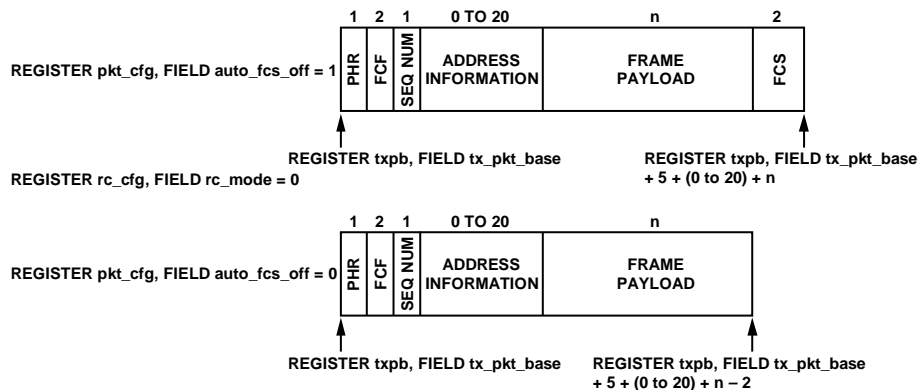

Figure 73. Field Format of TX_BUFFER

IEEE 802.15.4-2006 Transmitter Timing and Control

This section applies when IEEE 802.15.4-2006 packet mode is enabled. Accurate control over the transmission slot timing is maintained by two delay timers (Register `delaycfg1`, Field `tx_mac_delay` and Register `delaycfg2`, Field `mac_delay_ext`), which introduce a controlled delay between the rising edge of the `CS` signal following the `RC_TX` command and the start of the transmit operation. Figure 74 illustrates the timing of the transmit operation assuming that the ADF7242 was operating in `PHY_RDY, RX`, or `TX` state prior to the execution of an `RC_TX` command.

If enabled, the external PA interface, as described in the Power Amplifier section, is powered up prior to the synthesizer calibration to allow sufficient time for the bias servo loop to settle. Ramp-up of the PA is completed shortly before the overall MAC delay has elapsed. If enabled, an `rc_ready` interrupt (see the Interrupt Controller section) is generated at the transition into the `TX` state. Following the completion of the PA ramp-up phase, the transceiver enters the `TX` state. The minimum and maximum time for the PA ramp-up to complete prior to the transceiver entering the `TX` state given by Parameter `t35` in Table 14 also applies to IEEE 802.15.4-2006 transmit mode.

The radio controller first transmits the automatically generated preamble and SFD. If it has been enabled, an SFD interrupt is asserted after the SFD is transmitted. The packet manager then reads `TX_BUFFER`, starting with the PHR byte and transmits its contents. Following the transmission of the entire frame, the radio controller turns the PA off and asserts a `tx_pkt_sent` interrupt. The ADF7242 then automatically returns to the `PHY_RDY` state unless automatic operating modes have been configured.

By default, the synthesizer is recalibrated each time an `RC_TX` command is issued. Figure 75 shows the synthesizer calibration sequence that is performed each time the transceiver enters the `TX` state. The total TX MAC delay is defined by the combined delay configured with Register `delaycfg1`, Field `tx_mac_delay`

and Register `delaycfg2`, Field `mac_delay_ext`. Register `delaycfg1`, Field `tx_mac_delay` is programmable in steps of 1 μ s, whereas Register `delaycfg2`, Field `mac_delay_ext` is programmable in steps of 4 μ s. The default value of Register `delaycfg1`, Field `tx_mac_delay` is the length of 12 IEEE 802.15.4-2006-2.4 GHz symbols or 192 μ s.

The default value of Register `delaycfg2`, Field `mac_delay_ext` is 0 μ s. Following the issue of the `RC_TX` command, while the delay defined by Register `delaycfg1`, Field `tx_mac_delay` is elapsing, Register `delaycfg2`, Field `mac_delay_ext` can be updated up until the time, `t27`, specified in Table 13. This allows a dynamic adjustment of the transmission timing for acknowledge (ACK) frames for networks using slotted CSMA/CA. To ensure correct settling of the synthesizer prior to PA ramp-up, the total TX MAC delay should not be programmed to a value shorter than specified by the `PHY_RDY` or `RX` to `TX` timing specified in Table 10. The `RC_TX` command can be aborted up to the time specified by Parameter `t28` in Table 13 by means of issuing an `RC_PHY_RDY`, `RC_RX`, or `RC_IDLE` command.

The VCO calibration (`VCO_cal`) can be skipped if shorter turnaround times are required. Skipping the VCO calibration is possible if the channel frequency control word `ch_freq[23:0]` has remained unchanged since the last `RC_PHY_RDY`, `RC_RX`, `RC_CCA`, or `RC_TX` command was issued with `VCO_cal` enabled. The initialization, synthesizer settling, and PA ramping phases are mandatory however because the synthesizer bandwidth is changed between receive and transmit operation. Skipping the VCO calibration is an option for single-channel communication systems, or systems where an ACK frame is transmitted on the same channel upon reception of a packet.

`VCO_cal` is skipped by setting Register `vco_cal_cfg`, Field `skip_vco_cal` = 15. In this case, `tx_mac_delay` can be reduced to 140 μ s. The VCO calibration is executed if Register `vco_cal_cfg`, Field `skip_vco_cal` = 9.

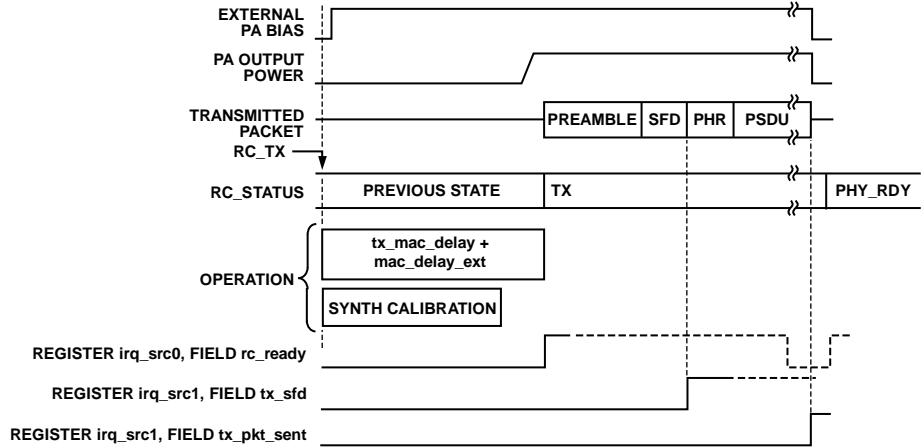

Figure 74. Transmit Timing and Control (IEEE 802.15.4-2006 Mode)

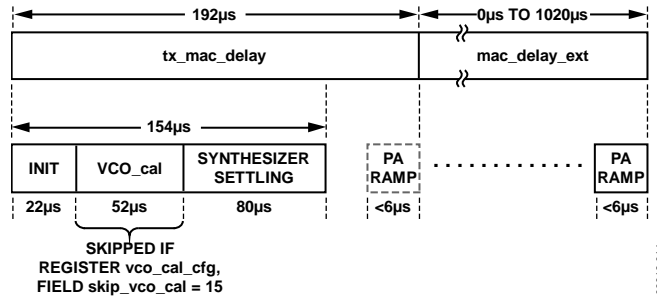

Figure 75. Synthesizer Calibration Following RC_TX

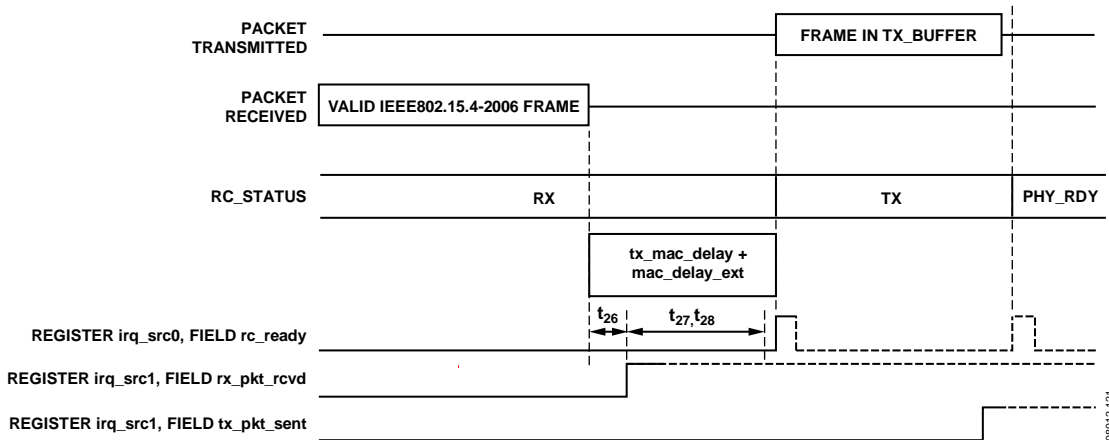

Figure 76. IEEE 802.15.4 Auto RX-to-TX Turnaround Mode

IEEE 802.15.4 AUTOMATIC RX-TO-TX TURNAROUND MODE

The ADF7242 features an automatic RX-to-TX turnaround mode when it is operating in IEEE 802.15.4-2006 packet mode (Register `rc_cfg`, Field `rc_mode` = 0). The automatic RX-to-TX turnaround mode facilitates the timely transmission of acknowledgment frames.

Figure 76 illustrates the timing of the automatic RX-to-TX turnaround mode. When enabled by setting Register `buffercfg`, Field `auto_rx_to_tx_turnaround`, the ADF7242 automatically enters the TX state following the reception of a valid IEEE 802.15.4-2006 frame. After the combined transmit MAC delay (`tx_mac_delay` + `mac_delay_ext`), the ADF7242 enters the TX state and transmits the frame stored in `TX_BUFFER`. After the transmission is complete, the ADF7242 enters the `PHY_RDY` state. There is a 38 μs delay between the reception of the last symbol and the generation of the `rx_pkt_rcvd` interrupt. The transmit MAC delay timeout period begins immediately after the reception of the last symbol. Therefore, the host MCU has up to `t28` μs (see Table 13) after a frame has been received to cancel the transmit operation by means of issuing an `RC_IDLE`, `RC_PHY_RDY`, or `RC_RX` command.

TRANSMITTER IN GFSK/FSK MODE

Packet Mode GFSK/FSK Transmission

The packet manager provides support for proprietary GFSK/FSK payload formats. Packet fields applicable to GFSK/FSK packet mode are shown in Table 23. In transmit mode, the packet manager can be configured to add preamble and sync words to the payload data stored in the packet RAM. It can also optionally calculate and transmit a CRC word.

To enable GFSK/FSK transmit packet mode operation, set Register `rc_cfg`, Field `rc_mode` = 4; 0x13E[7:0]). The host MCU writes the payload data to the packet ram. The location of transmit data in the packet RAM is defined by the value in Register `tx_pb`, Field `tx_pkt_base` (Location 0x314). This holds the address of the first byte of the transmit payload data in the packet RAM.

The preamble, sync word, and CRC word can be automatically added by the packet manager to the data stored in the packet RAM for transmission. Figure 77 shows the fields stored in the packet buffer.

Preamble

The preamble is a 0xAA sequence, with a programmable length. It is necessary to have preamble at the beginning of the packet to allow time for the receiver AGC, AFC, and clock and data recovery circuitry to settle before the start of the sync word. The required preamble length depends on the radio configuration. Table 38 in the Configuration Values for GFSK/FSK Packet and SPORT Modes section provides data on required preamble length for some examples of different configurations.

The total length of the preamble transmitted is equal to the number of bytes set in Register `fsk_preamble` (0x102) added to the number of bytes set in Register `fsk_preamble_num_validate` (0x3F3), along with any additional preamble bits required to pad the SWD (see the Sync Word (SWD) section for details).

Sync Word (SWD)

The value of the SWD is set in the `sync_word0`, `sync_word1`, and `sync_word2` registers (0x10C, 0x10D, and 0x10E). The SWD is transmitted most significant bit first starting with `sync_word2`. The transmitted sync word is a multiple of eight bits. Therefore, for nonbyte length sync words, the transmitted sync pattern should be padded with the preamble pattern, as shown in Table 24.

Payload Length

The payload length is defined as the number of bytes from the end of sync word to the start of the CRC.

CRC

An optional CRC-16 can be appended to the packet. The CRC polynomial used is:

$$g(x) = x^{16} + x^{12} + x^5 + 1$$

To disable the automatic appending of a CRC to the packet, set Register `pkt_cfg`, Field `auto_fcs_off` = 1. This field is set to 0 by default.

Postamble

The packet manager automatically appends two bytes of postamble to the end of the transmitted packet. Each byte of postamble is 0xAA. The first byte is transmitted immediately after the CRC. The PA ramp-down begins immediately after the first postamble byte. The second byte is transmitted while the PA is ramping down.

Table 23. Description of Fields Applicable to GFSK/FSK Packet Transmission

Field	Packet Structure					
			Payload		CRC	Postamble
	Preamble	SWD	Length	Payload Data		
Field Length	1 to 256 bytes	1 to 4 bytes	2 bytes	0 to 127 bytes	2 bytes	1 byte
Optional Field	No	No	N/A	N/A	Yes	No
Added in Transmit and Removed in Receive	Yes	Yes	N/A	N/A	Yes	Yes
Host Writes These Fields to Packet RAM	No	No	Yes	Yes	Optional	No
Fully Programmable Parameter	Only length	Yes	Yes	Yes	No	No

Table 24. Sync Word Programming Examples

Required Sync Word (Binary, First Bit Being First in Time)	Register Sync_cfg, Field sync_len	sync_word2	sync_word1	sync_word0	Transmitted Sync Word (Binary, First Bit Being First in Time)	Receiver Sync Word Match Length (Bits)
000100100011010001010110	24	0x12	0x34	0x56	0001_0010_0011_0100_0101_0110	24
111010011100101000100	21	0xBD	0x39	0x44	1011_1101_0011_1001_0100_0100	21
0001001000110100	16	0xAA	0x12	0x34	1010_1010_0001_0010_0011_0100	16
011100001110	12	0xAA	0xA7	0x0E	1010_1010_1010_0111_0000_1110	12
00010010	8	0xAA	0xAA	0x12	1010_1010_1010_1010_0001_0010	8
011100	6	0xAA	0xAA	0x9C	1010_1010_1010_1010_1001_1100	6

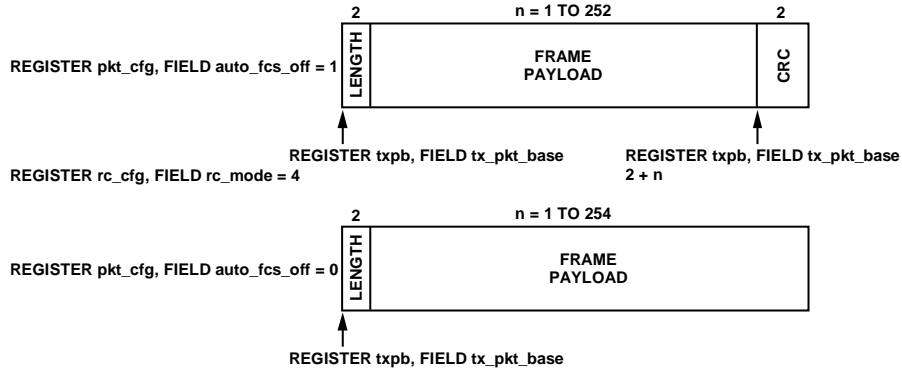

Figure 77. Format of GFSK/FSK Packets Stored by the Packet Manager in TX_BUFFER

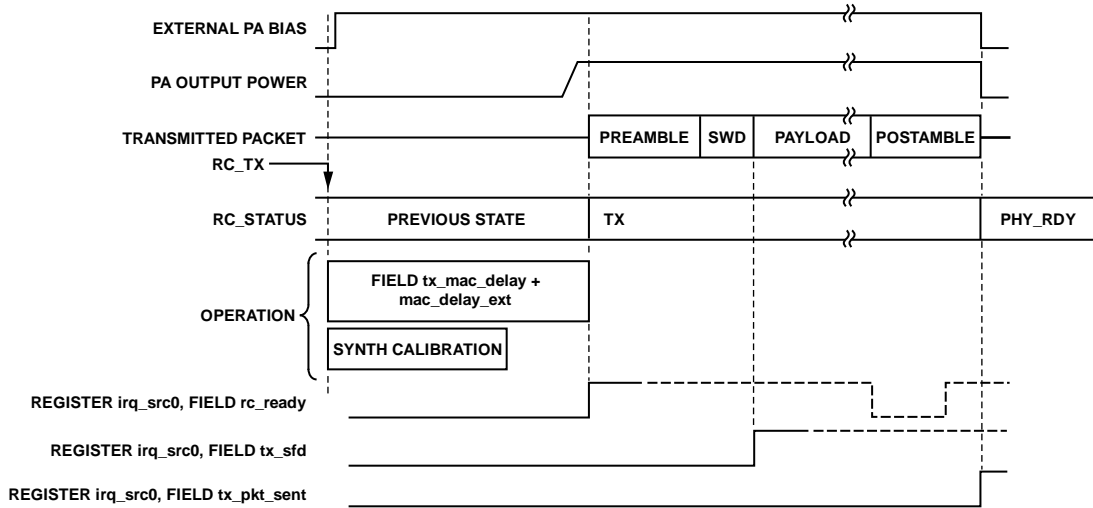

Figure 78. TX Timing and Control GFSK/FSK Packet Mode

SPORT MODE GFSK/FSK Transmitter Timing and Control

For GFSK/FSK TX SPORT mode operation, set Register rc_cfg, Field rc_mode = 3; 0x13E[7:0]). Refer to the SPORT Interface section for further details.

Figure 79 illustrates the timing of the transmit operation in GFSK/FSK TX SPORT mode. Following the transition into the TX state, the packet manager transmits SPORT input data until the TX state is left with an appropriate command. Because the

packet format is entirely under user control, no tx_sfd and tx_pkt_sent interrupts are generated. The calibration sequence shown in Figure 75 in the IEEE 802.15.4-2006 Transmitter Timing and Control section is fully applicable to GFSK/FSK transmit SPORT mode.

Table 25 shows the latency between data at the SPORT interface input and the modulated RF output signal transmitted.

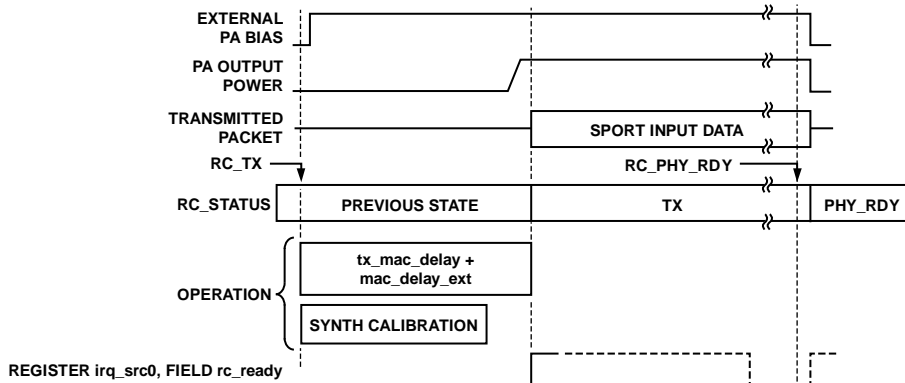

Figure 79. TX Timing and Control (GFSK/FSK SPORT Mode)

Table 25. Transmit Latency for Selected Data Rates

Bit Rate (kbps)	GFSK	FSK
62.5	32 μs (two bit periods)	8.025 μs (~½ bit period)
125	16 μs (two bit periods)	4.063 μs (~½ bit period)
250	8 μs (two bit periods)	2.063 μs (~½ bit period)
500	4 μs (two bit periods)	1.063 μs (~½ bit period)
1000	2 μs (two bit periods)	563 ns (~½ bit period)
2000	1 μs (two bit periods)	332 ns (~½ bit period)

POWER AMPLIFIER

The integrated power amplifier (PA) is connected to the RFIO2P and RFIO2N RF ports. It is equipped with a built-in harmonic filter to simplify the design of the external harmonic filter. The output power of the PA is set with Register `extpa_msc`, Field `pa_pwr` with an average step size of 2 dB. The step size increases at the lower end of the control range. Refer to Figure 65 for the typical variation of output power step size with the control word value. The PA also features a high power mode, which can be enabled by setting Register `pa_bias`, Field `pa_bias_ctrl` = 63 and Register `pa_cfg`, Field `pa_bridge_dbias` = 21.

PA Ramping Controller

The PA ramping controller of the ADF7242 minimizes spectral splatter generated by the transmitter. Upon entering the TX state, the ramping controller automatically ramps the output power of the PA from the minimum output power to the specified nominal value. In packet mode, transmission of the packet commences after the ramping phase. When the transmission of the packet is complete or the TX state is exited, the PA is turned off immediately. It is also possible to allow the PA to ramp down its output power using the same ramp rate for the ramp-up phase, by setting Register `ext_ctrl`, Field `pa_shutdown_mode` to 1.

Figure 80 illustrates the shape of the PA ramping profile and its timing. It follows a linear-in-dB shape. The ramp time depends on the output power setting in Register `extpa_msc`, Field `pa_pwr` and is specified with Register `pa_rr`, Field `pa_ramp_rate` according to the following equation:

$$t_{ramp} = 2^{pa_rr.pa_ramp_rate} \times 2.4 \text{ ns} \times extpa_msc.pa_pwr$$

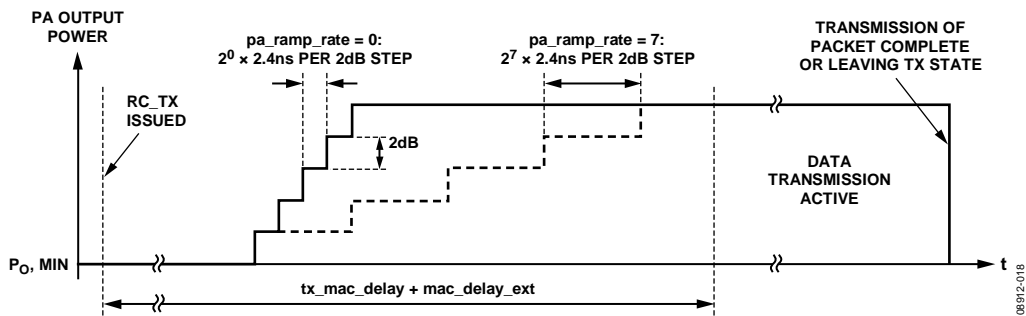

Figure 80. PA Ramping Profile

External PA Interface

The ADF7242 has an integrated biasing block for external PA circuits as shown in Figure 81. It is suitable for external PA circuits based on a single GaAs MOSFET and a wide range of integrated PA modules. The key components are shown in Figure 82. A switch between Pin VDD_BAT and Pin PAVSUP_ATB3 controls the supply current to the external FET. PABIOP_ATB4 can be used to set a bias point for the external FET. The bias point is controlled by a 5-bit DAC and/or a bias servo loop.

To have the external PA interface under direct control of the host MCU, set Register `ext_ctrl`, Field `extpa_auto_en` = 0. The host MCU can then use Register `pd_aux`, Field `extpa_bias_en` to enable or disable the external PA. If Register `ext_ctrl`, Field `extpa_auto_en` = 1, the external PA automatically turns on when entering, and turns off when exiting the TX state. If this setting is used, the host MCU should not alter the configuration of Register `pd_aux`, Field `extpa_bias_en`.

The function of the two pins, PAVSUP_ATB3 and PABIAOP_ATB4, depends on the mode selected with Register `extpa_msc`, Field `extpa_bias_mode`, as shown in Table 26.

The reference current source for the DAC is controlled with Register `extpa_msc`, Field `extpa_bias_src` (0x3AA[3]). If Register `extpa_msc`, Field `extpa_bias_src` = 0, the current is derived from the external bias resistor. If Register `extpa_msc`, Field `extpa_bias_src` = 1, the current is derived from the internal reference generator. The first option is more accurate and is recommended whenever possible.

External PA Interface Modes

- Mode 0 allows supply to an external circuit to be switched on or off. This is useful for circuits that have no dedicated power-down pin and/or have a high power-down current.
- Mode 1 allows the supply to an external circuit to be switched on or off. In addition, the PABIAOP_ATB4 pin acts as a programmable current source. A programmable voltage can be generated if a suitable resistor is connected between PABIAOP_ATB4 and GND.
- Mode 2 allows the supply to an external PA circuit to be switched on or off. In addition, the PABIAOP_ATB4 pin acts as a programmable current sink. A programmable voltage can be generated if a suitable resistor is connected between PABIAOP_ATB4 and VDD_BAT.
- Mode 3 is the same as Mode 1, except that the switch between PAVSUP_ATB3 and VDD_BAT is open.
- Mode 4 is the same as Mode 2, except that the switch between PAVSUP_ATB3 and VDD_BAT is open.
- Mode 5 is intended for a PA circuit based on a single external FET. The supply voltage to this FET is controlled through the PAVSUP_ATB3 pin to ensure a low leakage current in the power-down state. The bias servo loop controls the gate bias voltage of the external FET such that the current through the supply switch is equal to a

- reference current. The reference current for the bias servo loop is generated by the 5-bit reference DAC. In this mode, the bias servo loop expects the current in the FET to increase with increasing voltage at the PABIAOP_ATB4 output.
- Mode 6 is the same as Mode 5, except that the bias servo loop expects the current in the FET to increase with decreasing voltage at the PABIAOP_ATB4 output.

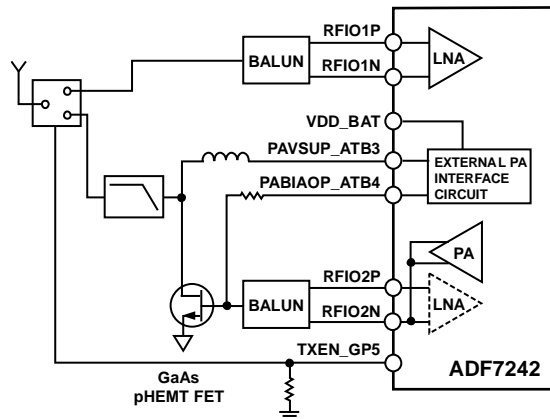

Figure 81. Typical External PA Applications Circuit

Table 26. PA Interface

Register extpa_msc, Field extpa_bias_mode	Register pd_aux, Bit extpa_bias_en ¹	VDD_BAT to PAVSUP_ATB3 Switch	Function of Pin PABIAOP_ATB4
X ²	0	Open	Not used
0	1	Closed	Not used
1	1	Closed	Current source
2	1	Closed	Current sink
3	1	Open	Current source
4	1	Open	Current sink
5	1	Closed	Bias current servo output, positive polarity
6	1	Closed	Bias current servo output, negative polarity
7	1	Reserved	Reserved

¹ Autoenabled when Register ext_ctrl, Field extpa_auto_en = 1.

² X = don't care.

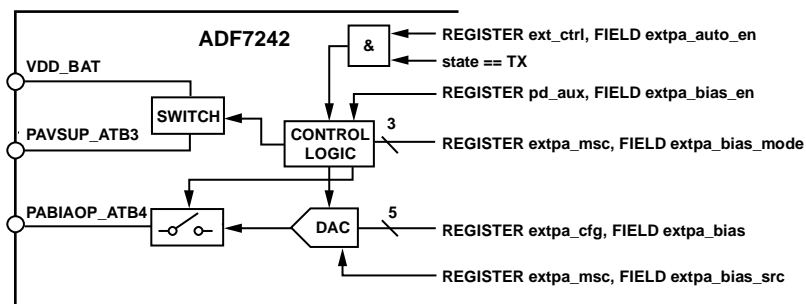

Figure 82. Details of External PA Interface circuit

RECEIVER

RECEIVE OPERATING MODES

The four primary receiver operating modes are

- IEEE 802.15.4-2006 packet manager mode
- IEEE 802.15.4-2006 SPORT mode
- GFSK/FSK packet manager mode
- GFSK/FSK SPORT mode

The desired operating mode is selected with Register `rc_cfg`, Field `rc_mode`. The SPORT modes are explained in more detail in the SPORT Interface section.

The data rate is set with Register `dr0`, Field `data_rate_high` and Register `dr1`, Field `data_rate_low` as documented in the Transmitter section. The data rate is automatically configured in IEEE 802.15.4-2006 mode.

RECEIVER IN IEEE 802.15.4-2006 MODE

IEEE 802.15.4-2006 Reception

When IEEE 802.15.4-2006 mode is selected, the output of the post demodulator filter is fed into a bank of correlators, which compare the incoming data sequences to the expected IEEE 802.15.4-2006 sequences. The IEEE 802.15.4-2006 receiver block operates in three primary states.

- Preamble qualification
- Symbol timing recovery
- Data symbol reception

During preamble qualification, the correlators check for the presence of preamble. When preamble is qualified, the device enters symbol timing recovery mode. The device symbol timing is achieved once a valid SFD is detected. The ADF7242 supports programmable SFDs. Refer to the IEEE 802.15.4-2006 Programmable SFD section for further details.

The received symbols are then passed to the packet manager in packet mode or the SPORT interface in SPORT mode. In SPORT mode, four serial clocks are output on Pin `TRCLK_CKO_GP3`, and four data bits are shifted out on Pin `DR_GP0` for each received symbol. Refer to the SPORT Interface section for further details.

If in packet mode, when the packet manager determines the end of a packet, the ADF7242 automatically transitions to `PHY_RDY` or `TX` or remains in `RX`, depending on the setting in Register `buffercfg`, Field `rx_buffer_mode` (see IEEE 802.15.4-2006 Receiver Configuration in Packet Mode section). If in SPORT mode, the part remains in `RX` until the user issues a command to change to another state.

IEEE 802.15.4-2006 Programmable SFD

An alternative to the standard IEEE 802.15.4-2006 SFD byte can optionally be selected by the user. The default setting of Register `sfd_15_4`, Field `sfd_symbol_1` and Field `sfd_symbol_2` (0x3F4[7:0]) is the standard IEEE 802.15.4-2006 SFD. If the user programs this register with an alternative value, this is used as the SFD in

receive and transmit in IEEE 802.15.4-2006 mode. The requirements are as follows:

- The value must not be a repeated symbol (for example, not 0x11 or 0x22).
- The value must not be similar to the preamble symbol (that is, not Symbol 0x0 or Symbol 0x8).

IEEE 802.15.4-2006 Receiver Configuration in Packet Mode

IEEE 802.15.4-2006 mode with packet management support is selected when Register `rc_cfg`, Field `rc_mode` = 0 (0x13E[7:0]). `RX_BUFFER` is overwritten when the ADF7242 enters the `RX` state following an `RC_RX` command and an SFD is detected. The SFD is stripped off the incoming frame, and all data following and including the frame length (PHR) is written to `RX_BUFFER`.

If Register `pkt_cfg`, Field `auto_fcs_off` = 1, the FCS of the incoming frame is stored in `RX_BUFFER`. When the entire frame has been received, an `rx_pkt_rcvd` interrupt is asserted irrespective of the correctness of the FCS. If `auto_fcs_off` = 0, the radio controller calculates the FCS of the incoming frame according to the FCS polynomial defined in the IEEE 802.15.4-2006 standard (see Equation 1), and compares the result against the FCS of the incoming frame. An `rx_pkt_rcvd` interrupt is asserted only if both FCS fields match. The FCS is not written to `RX_BUFFER` but is replaced with the measured RSSI and signal quality indicator (SQI) values of the received frame (see Figure 83).

$$G_{16}(x) = x^{16} + x^{12} + x^5 + 1 \quad (1)$$

The behavior of the radio controller following the reception of a frame can be configured with Register `buffercfg`, Field `rx_buffer_mode` (0x107[1:0]). With the default setting `rx_buffer_mode` = 0, the part reverts automatically to `PHY_RDY` when an `rx_pkt_rcvd` interrupt condition occurs. This mode prevents `RX_BUFFER` from being overwritten by the next frame before the host MCU can read it from the ADF7242. This is because a new frame is always written to `RX_BUFFER` starting from the address stored in Register `rxpb`, Field `rx_pkt_base` (0x315[7:0]). Note that reception of the next frame is inhibited until the MAC delay following an `RC_RX` command has elapsed.

If Register `buffercfg`, Field `rx_buffer_mode` = 1 (0x107[1:0]), the part remains in the `RX` state, and the reception of the next packet is enabled one MAC delay period after the frame has been written to `RX_BUFFER`. Depending on the network setup, this mode can cause an unnoticed violation of `RX_BUFFER` integrity if a frame arrives prior to the MCU having read the frame from `RX_BUFFER`.

If Register `buffercfg`, Field `rx_buffer_mode` = 2 (0x107[1:0]), the reception of frames is disabled. This mode is useful for RSSI measurements and CCA, if the contents of `RX_BUFFER` are to be preserved.

RECEIVER CALIBRATION

The receive path is calibrated each time an RC_RX command is issued. Figure 84 outlines the synthesizer and receive path calibration sequence and timing for the IEEE 802.15.4-2006 mode of operation. The calibration step VCO_cal is omitted by setting Register vco_cal_cfg, Field skip_vco_cal = 15 (0x36F[3:0]), which is an option if the value of ch_freq[23:0] remains

unchanged during transitions between the PHY_RDY, RX, and TX states. The synthesizer settling phase is always required because the PLL bandwidth is optimized differently for RX and TX operation. The static offset correction phase (OCL_stat) and dynamic offset correction phase (OCL_dyn) are also mandatory.

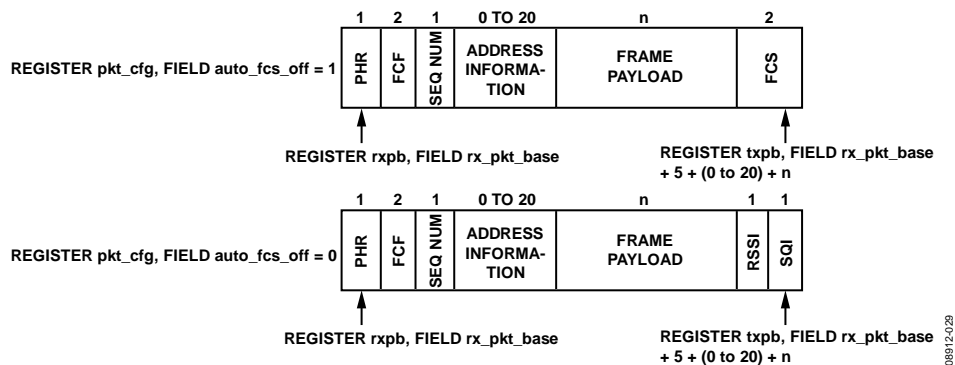

Figure 83. IEEE 802.15.4-2006 Packet Fields Stored by the Packet Manager in RX_BUFFER

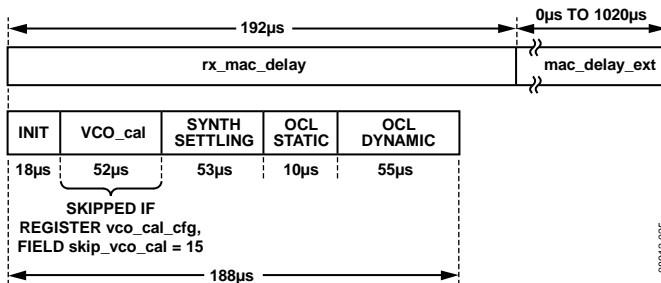

Figure 84. RX Path Calibration, IEEE 802.15.4-2006 Mode

IEEE 802.15.4-2006 RECEIVE TIMING AND CONTROL

The IEEE 802.15.4-2006 operating mode is configured with Register `rc_cfg`, Field `rc_mode` = 0 (0x13E[7:0]) for packet mode, and Register `rc_cfg`, Field `rc_mode` = 2 for IEEE 802.15.4 RX SPORT mode. See the SPORT Interface section for details on the operation of the SPORT interface. By default, ADF7242 performs a synthesizer and a receiver path calibration immediately after it receives an `RC_RX` command. The transition into the RX state occurs after the receiver MAC delay has elapsed. The total receiver MAC delay is determined by the sum of the delay times configured in Register `delaycfg0`, Field `rx_mac_delay` (0x109[7:0]) and Register `delaycfg2`, Field `mac_delay_ext` (0x10B[7:0]). Register `delaycfg0`, Field `rx_mac_delay` (0x109[7:0]) is programmable in steps of 1 μ s, whereas Register `delaycfg2`, Field `mac_delay_ext` (0x10B[7:0]) is programmable in steps of 4 μ s. For IEEE 802.15.4-2006 RX operation, Register `delaycfg2`, Field `mac_delay_ext` is typically set to 0. It can, however, be dynamically used to accurately align the RX slot timing.

Figure 85 shows the timing sequence for IEEE 802.15.4-2006 packet mode. If IEEE 802.15.4-2006 SPORT mode is enabled, the timing sequence is the same except that no `rx_pkt_rcvd` interrupt is generated and no automatic transition into the `PHY_RDY` state occurs.

When entering the RX state, if Register `cca2`, Field `rx_auto_cca` = 1 (0x106[1]), a CCA measurement is started. The radio controller asserts a `cca_complete` interrupt when the CCA result is available in the status word. Upon detection of the SFD, the radio controller asserts an `rx_sfd` interrupt, which can be used by the host MCU for synchronization purposes. By default, the ADF7242 transitions into the `PHY_RDY` state when a valid frame has been received into `RX_BUFFER` and, if enabled, an `rx_pkt_rcvd` interrupt is asserted. This mechanism protects the integrity of `RX_BUFFER`. The RX state can be exited at any time by means of an appropriate radio controller command.

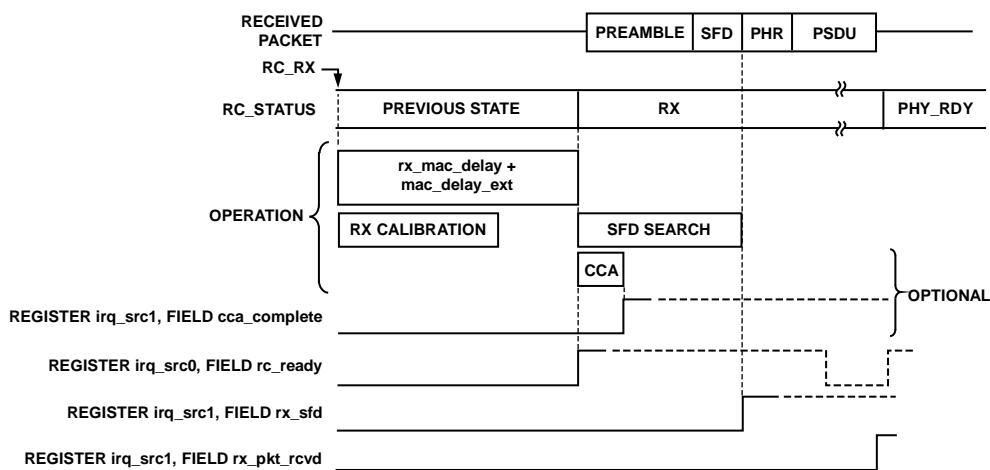

Figure 85. RX Timing and Control (IEEE 802.15.4-2006 Packet Mode)

08912-002

CLEAR CHANNEL ASSESSMENT (CCA)

The CCA function of the ADF7242 complies with CCA Mode 1 as per IEEE 802.15.4-2006. It is also applicable for the GFSK/FSK mode of operation.

A CCA can be specifically requested by means of an RC_CCA command or automatically obtained when the transceiver enters the RX state. In both cases, the start of the CCA averaging window is defined by when the RC_CCA or RC_RX command is issued and when the delay is configured in Register delaycfg0, Field rx_mac_delay (0x109[7:0]) and Register delaycfg2, Field mac_delay_ext (0x10B[7:0]). The CCA result is determined by comparing Register cca1, Field cca_thres (0x105[7:0]) against the average RSSI value measured throughout the CCA averaging window. If the measured RSSI value is less than the threshold value configured in Register cca1, Field cca_thres (0x105[7:0]), CCA_RESULT in the status word is set; otherwise, it is reset. The cca_complete interrupt is asserted when CCA_RESULT in the status word is valid.

Figure 86 shows the timing sequence after issuing the RC_CCA command when Register cca2, Field continuous_cca = 0 (0x106[2]). Following the RC_CCA command, the transceiver starts the CCA observation window after the delay specified by the sum of Register delaycfg0, Field rx_mac_delay (0x109[7:0]) and Register delaycfg2, field mac_delay_ext (0x10b[7:0]) has elapsed. A cca_complete interrupt is asserted at the end of the CCA averaging window, and the transceiver enters the PHY_RDY state.

When Register cca2, Field continuous_cca = 1 (0x106[2]), the transceiver remains in CCA state and continues to calculate

CCA results repeatedly until a RC_PHY_RDY command is issued. This case is illustrated in Figure 87. The first cca_complete interrupt occurs when the first CCA averaging window after the RX MAC delay has elapsed. The transceiver then repeatedly restarts the CCA averaging window each time a cca_complete interrupt is asserted.

This configuration is useful for longer channel scans. CCA_RESULT in the status word can be used to identify if the configured CCA RSSI threshold value has been exceeded during a CCA averaging period. Alternatively, the RSSI value in Register rrb, Field rssi_readback can be read by the host MCU after each cca_complete interrupt. As indicated in Figure 87, the RSSI readback value holds the results of the previous RSSI measurement cycle throughout the CCA averaging window and is updated only shortly before the cca_complete interrupt is asserted.

The RSSI averaging time is programmable with Register agc_cfg5, Field rssi_avg_time (0x3B9[1:0]) according to Table 113. While operating the transceiver in IEEE 802.15.4-2006 mode, setting Register agc_cfg5, Field rssi_avg_time = 2 (0x3B9[1:0]) is required for compatibility.

Table 27. RSSI Averaging Time

Register agc_cfg5, Field rssi_avg_time (0x3B9[1:0])	CCA Averaging Period
0	16 μs
1	32 μs
2	64 μs
3	128 μs

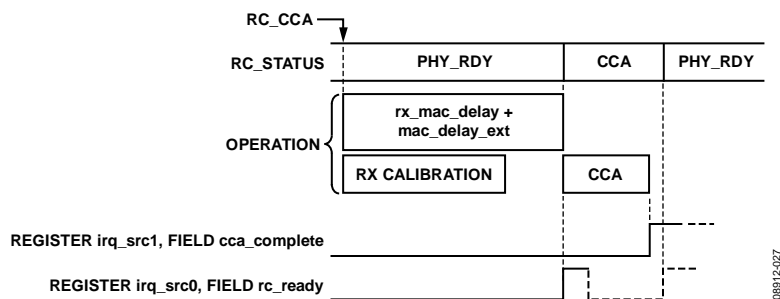

Figure 86. CCA Timing Sequence, Register cca2, Bit continuous_cca = 0 (0x106[2])

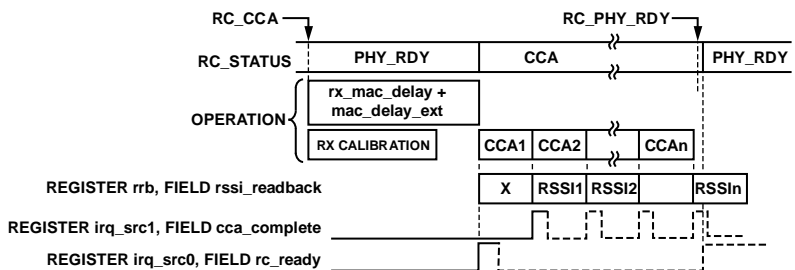

Figure 87. CCA Timing Sequence, Register cca2, Bit continuous_cca = 1 (0x106[2])

ADF7242

LINK QUALITY INDICATION (LQI)

The link quality indication (LQI) is defined in the IEEE 802.15.4-2006 standard as a measure of the signal strength and signal quality of a received IEEE 802.15.4-2006 frame. The ADF7242 makes several measurements available from which an IEEE 802.15.4-2006-compliant LQI value can be calculated in the MCU. The first parameter is the RSSI value (see the Automatic Gain Control (AGC) and Receive Signal Strength Indicator (RSSI) subsection of the Receiver Radio Blocks section).

The second parameter required for the LQI calculation can be read from Register lrb, Field sqi_readback (0x30D[7:0]), which

contains an 8-bit value representing the quality of a received IEEE 802.15.4-2006 frame. It increases monotonically with the signal quality and must be scaled to comply with the IEEE 802.15.4-2006 standard.

If the ADF7242 is operating in IEEE 802.15.4-2006 packet mode (Register rc_cfg, Field rc_mode = 0 (0x13E[7:0])), and Register pkt_cfg, Bit auto_fcs_off = 0 (0x108[0]), the SQI of a received frame is measured and stored together with the frame in RX_BUFFER. The SQI is measured over the entire packet and stored in place of the second byte of the FCS of the received frame in RX_BUFFER.

IEEE 802.15.4 AUTOMATIC TX-TO-RX TURNAROUND MODE

The ADF7242 features an automatic TX-to-RX turnaround mode when operating in IEEE 802.15.4-2006 packet mode. The automatic TX-to-RX turnaround mode facilitates the timely reception of acknowledgment frames.

Figure 88 illustrates the timing of the automatic TX-to-RX turnaround mode. When enabled by setting Register `buffercfg`, Field `auto_tx_to_rx_turnaround` (0x107[3]), the ADF7242 automatically enters the RX state following the transmission of an IEEE 802.15.4-2006 frame. After the combined receiver MAC delay (Register `delaycfg0`, Field `rx_mac_delay` + Register `delaycfg2`, Field `mac_delay_ext`), the ADF7242 enters the RX state and is ready to receive a frame into `RX_BUFFER`. Subsequently, when a valid IEEE 802.15.4-2006 frame is received, the ADF7242 enters the `PHY_RDY` state.

IEEE 802.15.4 FRAME FILTERING, AUTOMATIC ACKNOWLEDGE, AND AUTOMATIC CSMA/CA

The following IEEE 802.15.4-2006 functions are enabled by the firmware module, `RCCM_IEEEX`:

- Automatic IEEE 802.15.4 frame filtering
- Automatic acknowledgment of received valid IEEE 802.15.4 frames
- Automatic frame transmission using unslotted CSMA/CA with automatic retries

See the Downloadable Firmware Modules and Writing to the ADF7242 sections for details on how to download a firmware module to the ADF7242.

Frame Filtering

Frame filtering is available when the ADF7242 operates in IEEE 802.15.4 packet mode. The frame filtering function rejects received frames not intended for the wireless node. The filtering procedure is a superset of the procedure described in Section 7.5.6.2 (third filtering level) of the IEEE 802.15.4-2006 standard. Field `addon_en` in Register `pkt_cfg` controls whether frame filtering is enabled

Automatic Acknowledgment

The ADF7242 has a feature that enables the automatic transmission of acknowledgment frames after successfully receiving a frame. The automatic acknowledgment feature of the receiver can only be used in conjunction with the IEEE 802.15.4 frame filtering feature. When enabled, an acknowledgment frame is automatically transmitted when the following conditions are met:

- The received frame is accepted by the frame filtering procedure.
- The received frame is not a beacon or acknowledgment frame.
- The acknowledgment request bit is set in the FCF of the received frame.

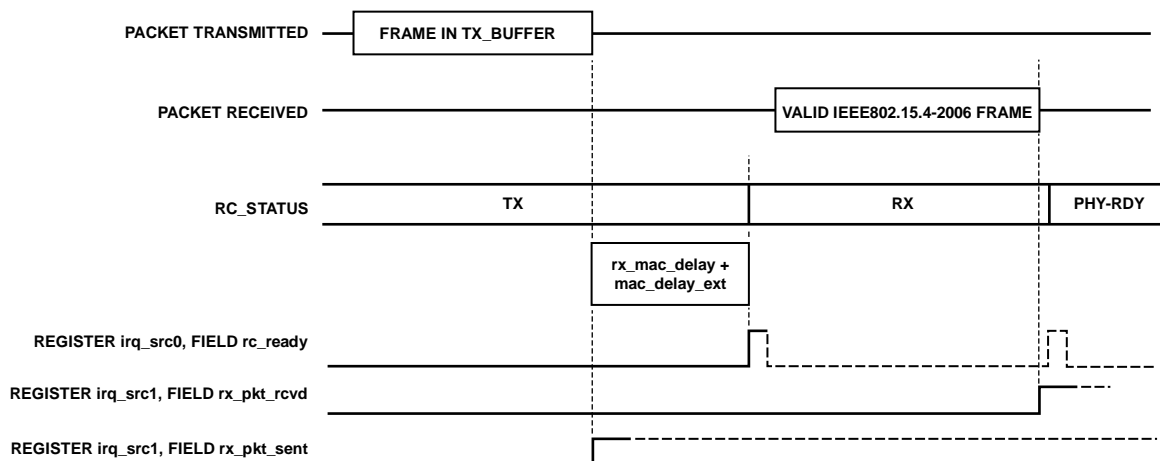

Figure 88. IEEE 802.15.4-2006 Auto TX-to-RX Turnaround Mode

Figure 89 shows the format of the acknowledgment frame assembled by the ADF7242. The sequence number (Seq. Num.) is copied from the frame stored in RX_BUFFER. The automatic acknowledgment feature of the receiver uses TX_BUFFER to store the constructed acknowledgment frame prior to its transmission. Any data present in TX_BUFFER is overwritten by the acknowledgment frame prior to its transmission.

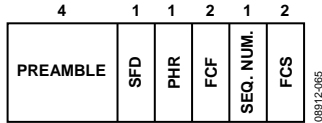

Figure 89. ACK Frame Format

The transmission of the ACK frame starts after the combined delay given by the sum of the delays specified in Register delaycfg1, Field tx_mac_delay and Register delay_cfg2, Field mac_delay_ext has elapsed. The default settings of Register delaycfg1, Field tx_mac_delay = 192 and Register delay_cfg2, Field mac_delay_ext = 0 result in a delay of 192 μs, which suits networks using unslotted CSMA/CA. Optionally, Register delay_cfg2, Field mac_delay_ext can be updated dynamically while the delay specified in Register delaycfg1, Field tx_mac_delay elapses. This option enables accurate alignment of the acknowledgment frame with the back-off slot boundaries in networks using slotted CSMA/CA.

When the receiver automatic acknowledgment mode is enabled, the ADF7242 remains in the RX state until a valid frame has been received. When enabled, an rx_pkt_rcvd interrupt is generated. The ADF7242 then automatically enters the TX state until the transmission of the acknowledgment frame is complete. When enabled, a tx_pkt_sent interrupt is generated to signal the end of the transmission phase. Subsequently, the ADF7242 returns to the PHY_RDY state.

Automatic Unslotted CSMA/CA Transmit Operation

The automatic CSMA/CA transmit operation automatically performs all necessary steps to transmit frames in accordance with the IEEE 802.15.4-2006 standard for unslotted CSMA/CA network operation. It includes automatic CCA retries with random backoff, frame transmission, reception of the acknowledgment frame, and automatic retries in the case of transmission failure. Partial support is provided for slotted CSMA/CA operation.

The number of CSMA/CA CCA retries can be specified between 0 and 5 in accordance with the IEEE 802.15.4 standard. The CSMA/CA can also be disabled, causing the transmission

of the frame to commence immediately after the MAC delay has expired. This configuration facilitates the implementation of the transmit procedure in networks using slotted CSMA/CA. In this case, the timing of the CCA operation must be controlled by the host MCU, and the number of retries must be set to 1.

Prior to the transmission of the frame stored in TX_BUFFER the radio controller checks if the acknowledge request bit in the FCF of that frame is set. If it is set, then an acknowledgment frame is expected following the transmission. Otherwise, the transaction is complete after the frame has been transmitted. The acknowledgment request bit is Bit 5 of the byte located at the address contained in Register txpb, Field tx_packet_base + 1.

Figure 90 depicts the automatic CSMA/CA operation. The firmware module download enables an additional command, RC_CSMACA, to initiate this CSMA/CA operation. It also enables an additional interrupt, csma_ca_complete, to be set to indicate when the CSMA/CA procedure is completed. As per the IEEE 802.15.4-2006 standard for unslotted CSMA/CA, the first CCA is delayed by a random number of backoff periods, where a unit backoff period is 320 μs. The CCA is carried out for a period of 128 μs as specified in the IEEE 802.15.4-2006 standard.

If a busy channel is detected during the CCA phase, the radio controller performs the next delay/CCA cycle until the maximum number of CCA retries specified has been reached. If the maximum number of allowed CCA retries has been reached, the operation is aborted and the device transitions to the PHY_RDY state.

If the CCA was successful, the radio controller changes the device state from the CCA state to the TX state and transmits the frame stored in TX_BUFFER. The minimum turnaround time from RX to TX is 106 μs. If neither the acknowledge request bit in the transmitted frame nor the csma_ca_turnaround bit are set, the device returns to the PHY_RDY state immediately upon completion of the frame transmission. Otherwise, it enters the RX state and waits for up to 864 μs for an acknowledgment. If an acknowledgment is not received within this time and the maximum number of frame retries has not been reached, the ADF7242 remains inside the frame transmit retry loop and starts the next CSMA/CA cycle. Otherwise, it exits to the PHY_RDY state. The procedure exits with a csma_ca_complete interrupt.

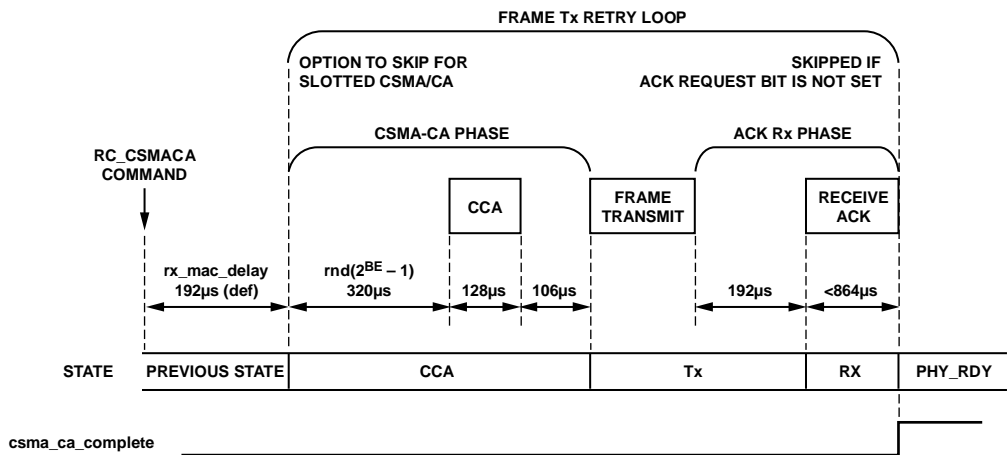

Figure 90. Automatic CSMA/CA Transmit Operation (with CCA)

08912-066

RECEIVER IN GFSK/FSK MODE

The packet manager can detect and interrupt the host MCU upon receiving a qualified preamble, sync word, or valid FCS. The packet manager then stores the received data payload in the packet RAM. This section describes the various configurations of the packet manager in receive mode.

GFSK/FSK Packet Mode Reception

To configure GFSK/FSK packet mode, set Register `rc_cfg`, Field `rc_mode = 4` (`0x13E[7:0]`). Register writes required to configure GFSK/FSK SPORT are given in the SPORT Interface section. Table 29 shows the fields applicable to GFSK/FSK packet reception, and Figure 91 shows which fields are stored by the packet manager in `RX_BUFFER`.

Preamble

This is a mandatory part of the packet that is automatically removed after receiving a packet. In receive mode, the preamble detection circuit tracks the received frame as a sliding window. The window is three bytes in length, and the preamble pattern is fixed at `0xAA`. The preamble bits are examined in 2-bit pairs (for example, `b10`). If either or both bits are in error, the pair is deemed erroneous. The possible erroneous pairs are `b00`, `b11`, and `b01`. The number of erroneous pairs tolerated in the preamble detection can be set by Register `fsk_preamble_config`, Field `fsk_preamble_match_level`, as shown in Table 28.

If `fsk_preamble_match` level is set to `0x0C`, the ADF7242 must receive 12 consecutive `b10` pairs (three bytes) to confirm valid preamble has been detected. Then, the preamble level must be maintained equal or above the detection threshold over a number of bytes to obtain full qualification. If the number of erroneous bit-pairs drops below the detection threshold before the end of the qualification time; the packet manager discards the preamble and restarts the detection.

The number of preamble bytes required for qualification can be set by Register `preamble_num_validate` (`0x3F3`). The user can select the option to automatically lock the AFC and/or AGC at this point. The lock AFC on preamble qualification can be enabled by setting Register `afc_config`, Field `afc_lock_mode = 0x3` (`0x3F7[1:0]`). The lock AGC on preamble detection can be enabled by setting Register `fsk_preamble_config`, Field `fsk_agc_lock_after_preamble` to 1 (`0x111[5]`).

Table 28. Preamble Detection Tolerance (Register `fsk_preamble_config`, Location `0x111`)

Value	Description
0x0C	0 errors allowed
0x0B	1 erroneous bit-pair allowed in 12 bit-pairs
0x0A	2 erroneous bit-pairs allowed in 12 bit-pairs
0x09	3 erroneous bit-pairs allowed in 12 bit-pairs
0x08	4 erroneous bit-pairs allowed in 12 bit-pairs
0x00	Preamble detection disabled

Table 29. Description of Fields Applicable to GFSK/FSK Packet Reception

Field	Packet Structure					
	Preamble	SWD	Payload		CRC	Postamble
			Length	Payload Data		
Receive Interrupt on Valid Field Detection	No	Yes	N/A	N/A	Yes	N/A
Programmable Field Error Tolerance in RX	Yes	Yes	N/A	N/A	N/A	N/A

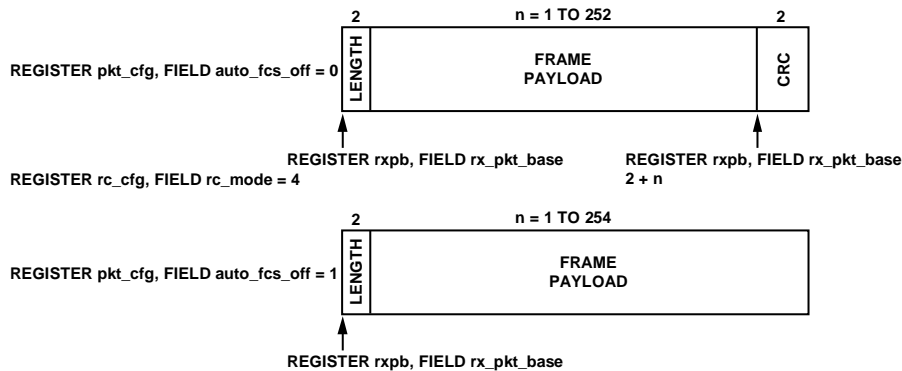

Figure 91. GFSK/FSK Packet Fields stored by the Packet Manager in `RX_BUFFER`

08912-090

When preamble has been qualified, the packet manager searches for a sync word. From the end of preamble, the chip processor searches for the sync word for a maximum duration of four bytes. This is illustrated in Figure 92. If sync word is detected during this window, the packet manager stores the received payload to packet RAM and computes the CRC (if enabled). If the sync word is not detected during this duration, the packet manager unlocks the AGC/AFC and then returns to searching for preamble.

Preamble detection can be disabled by setting Register `fsk_preamble_config`, Field `skip_preamble_detect_qual_high` (Location 0x111).

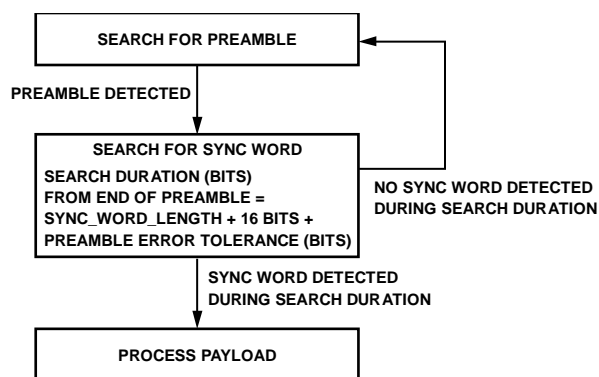

Figure 92. Search for Preamble and Search for Sync Word Routine By the Packet Manager

Sync Word (SWD)

This is the synchronization word that is used by the receiver for byte-level synchronization, while also providing an optional interrupt on detection. It is automatically removed after receiving a packet.

The value of the SWD is set in the `sync_word0`, `sync_word1`, and `sync_word2` registers (0x10C, 0x10D, and 0x10E). The SWD is transmitted most significant bit first starting with `sync_word2`. The SWD matching length at the receiver is set using Register `sync_config`, Field `sync_len` (0x10F[4:0]) and can be one bit to 24 bits in length.

The ADF7242 can provide an interrupt on reception of the programmed sync word. This feature can be used to alert the host microprocessor that a valid packet has been received. An error tolerance parameter can also be programmed that accepts a valid match when up to three bits of the sync word sequence are incorrect. The error tolerance value is set using the `sync_tol` setting in Register `sync_config` (0x10F[6:5]) as described in Table 30. On reception of a valid sync word, the chip processor automatically writes the receive payload to the packet RAM. The `rx_pkt_base` value in Register `rxpb` sets the location in packet RAM of the first byte of the received payload. For more details on packet RAM, refer to the Memory Map section.

Table 30. Sync Word Detection Tolerance (`sync_config`, Register 0x10F)

Value	Description
00	0 bit errors allowed
01	1 bit error allowed
10	2 bit errors allowed
11	3 bit errors allowed

CRC

To enable CRC detection on the receiver with the 16-bit CRC described in the Transmitter in GFSK/FSK Mode section, set Register `pkt_cfg`, Field `auto_fcs_off` = 0 (0x108[0]). This is the default setting. An interrupt on reception of a valid packet containing the correct CRC can be enabled by setting the `rx_pkt_rcvd` interrupt in Register `irq1_en1` or Register `irq2_en1`.

If it is desired to receive a packet that has a CRC word generated by a different CRC formula, the host MCU should set Register `pkt_cfg`, Field `auto_fcs_off` = 1. The CRC word received is stored in `RX_BUFFER`, as shown in Figure 91. An `rx_pkt_rcvd` interrupt is not generated; therefore, it is recommended that an `rx_sfd` interrupt be enabled to inform the host MCU when a packet has been received. Refer to the Interrupt Controller section for details.

Receive GFSK/FSK Demodulator

Figure 93 shows a block diagram of the receive demodulator. A correlator demodulator is used for 2FSK and GFSK demodulation. The quadrature outputs of the analog baseband filter are digitized and then fed to a digital frequency correlator that performs filtering and frequency discrimination of the FSK or GFSK signal.

For GFSK/FSK demodulation, data is recovered by comparing the output levels from two correlators. The performance of this frequency discriminator approximates that of a matched filter detector, which is known to provide optimum detection in the presence of additive white Gaussian noise (AWGN). This method of GFSK/FSK demodulation provides approximately 3 dB to 4 dB better sensitivity than a linear demodulator.

The correlator demodulator bandwidth must be configured with Register `dm_cfg0`, Field `discriminator_bw` (0x305[6:0]) to match the deviation frequency of the received signal. For applications

with low data rates, the frequency error between the local oscillator of the transmitter and receiver can be a significant fraction of the deviation frequency. This frequency error must be considered when optimizing the demodulator bandwidth setting to ensure reliable operation. The discriminator bandwidth setting is set by Register `dm_cfg0`, Field `discriminator_bw` (0x305[6:0]). The discriminator bandwidth setting can be calculated from

$$discriminator_bw[6:0] = \frac{3.25 \text{ MHz}}{FSK_dev + freq_error_max}$$

where:

FSK_dev is the GFSK/FSK frequency deviation in Hz (measured from the RF carrier to the Logic 0 or Logic 1 frequency).

freq_error_max is the maximum expected frequency error, in hertz (Hz), between the carrier frequency of the transmitted signal and the local oscillator (LO) frequency of the receiver.

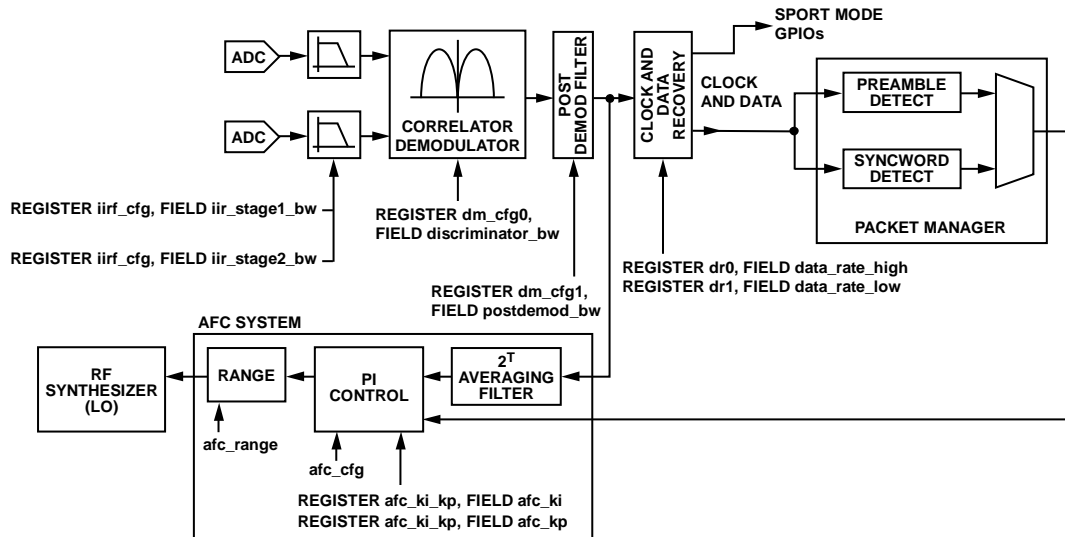

Figure 93. Structure of RX Demodulator

Automatic Frequency Correction (AFC)

As shown in Figure 93, the ADF7242 is equipped with a fully automatic real-time AFC function. It is used to maintain an optimal link budget in the presence of frequency errors between the local oscillators of the receiver and transmitter. AFC is supported in GFSK/FSK mode only.

When AFC is enabled, an internal control loop automatically monitors the frequency error during the preamble sequence of the packet and adjusts the synthesizer LO using an internal proportional integral (PI) control loop. The AFC frequency error measurement bandwidth is targeted specifically at the packet preamble sequence (dc free). When preamble is detected, the AFC is locked by the radio controller. AFC lock is released if the sync word is not detected immediately after the end of preamble. This can be due to false lock, poor quality preamble, and/or sync word. If the qualified preamble is followed by a qualified sync word, the AFC lock is maintained for the duration of the packet.

Setting Register `afc_cfg`, Field `afc_mode` = 3 (0x3F7[1:0]) enables AFC operation with automatic preamble locking, which is the recommended setting. The frequency error readback word in Register `afc_read`, Field `afc_freq_error` (0x3FA[7:0]) is continuously updated until the AFC is locked. The frequency correction is maintained if the ADF7242 transitions to another state (such as TX). It is overwritten with a new frequency correction value when the receiver next detects valid preamble, or it can be cleared by setting Register `afc_range`, Field `max_afc_range` = 0 and Register `afc_cfg`, Field `afc_mode` = 2.

The recommended settings for the AFC control loop parameters are Register `afc_ki_kp`, Field `afc_ki` = 9 and Register `afc_ki_kp`, Field `afc_kp` = 9. An example of AFC performance for a selection of data rates is given in Table 31.

The maximum AFC correction range is set by Register `afc_range`, Field `max_afc_range`. It has a resolution of 1 kHz. This setting helps prevent the AFC loop from attempting to acquire signals outside the frequency range of interest. The AFC detects and corrects frequency errors up to $\pm \text{max_afc_range}$ from the programmed channel frequency. The nominal channel frequency is set by the frequency control word, `ch_freq`[23:0]. The `max_afc_range` value is generally set to less than half the bandwidth of the baseband filter.

Table 31. Example AFC Performance

Parameter	2000 kbps, $f_{\text{DEV}} = \pm 500 \text{ kHz}$	500 kbps, $f_{\text{DEV}} = \pm 250 \text{ kHz}$
Preamble Length	11 bytes	7 bytes
Frequency Error Tolerance with AFC	$\pm 165 \text{ kHz}$	$\pm 190 \text{ kHz}$
Maximum AFC Correction Range	$\pm 80 \text{ kHz}$	$\pm 80 \text{ kHz}$
Frequency Error Tolerance Without AFC	$\pm 55 \text{ kHz}$	$\pm 90 \text{ kHz}$

Postdemodulator Filter

The digital post demodulator filter, shown in Figure 93, removes excess noise from the demodulator output. Its bandwidth is programmable with Register `dm_cfg1`, Field `postdemod_bw` (0x38B[7:0]) and should be optimized for the data rate used. If the bandwidth is set too narrow, performance degrades due to intersymbol interference. If the bandwidth is set too wide, performance degrades due to excess noise. For optimum performance, the post demodulator filter bandwidth should be set to $0.75 \times \text{data rate}$. The following formula can be used to determine the appropriate register setting:

$$\text{postdemod_bw} = \text{roundoff}(17 \times 10^{-5} \times (0.75 \times \text{data rate}[\text{bps}]) - 4 \times 10^{-11} (0.75 \times \text{data rate}[\text{bps}])^2)$$

Refer to the Device Configuration section for recommended postdemodulator filter settings and for example data rates.

Clock and Data Recovery (CDR)

An oversampled digital clock and data recovery (CDR) PLL is used to resynchronize the received bit stream to a local clock in all modulation modes. The data rate of the CDR is set by Register `dr0`, Field `data_rate_high` (0x30E[7:0]) and Register `dr1`, Field `data_rate_low` (0x30F[7:0]).

The maximum data rate tolerance of the CDR PLL is determined by the number of bit transitions in the transmitted packet. For example, if using GFSK/FSK with a 101010... preamble, a maximum tolerance of $\pm 3.0\%$ of the data rate is achieved.

This tolerance is reduced during the recovery of the remainder of the packet where data transitions may not occur on regular intervals.

However, it is possible to tolerate uncoded payload data fields and payload data fields with long run length coding constraints if the data rate tolerance and packet length are both constrained. More details of CDR operation using uncoded packet formats are described in the AN-915 Application Note.

The CDR is designed for fast acquisition of the recovered symbols during the preamble and typically achieves bit synchronization within five symbol transitions of preamble.

Receiver Calibration in GFSK/FSK Mode

The receive path is calibrated each time an RC_RX command is issued. The sequence is identical for IEEE 802.15.4 and GFSK/FSK mode of operation; the timing parameters, however, are different. Figure 94 outlines the synthesizer and receive path calibration sequence and timing for the GFSK/FSK mode of operation. (See the Receiver Calibration section for information on which calibration stages are mandatory and which are optional.)

In GFSK/FSK reception, the total receiver calibration time is 664 μ s. Assuming that Register delaycfg0, Field rx_mac_delay (0x109[7:0]) remains at the default delay setting of 192 μ s, this requires Register delaycfg2, Field mac_delay_ext (0x10B[7:0]) to be set to 472 μ s. Optimal receiver performance is achieved when no input signal is present during the receiver MAC delay.

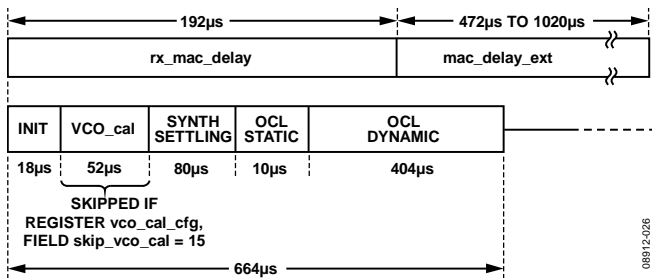

Figure 94. Receive Path Calibration, GFSK/FSK Mode

GFSK/FSK Receive Timing and Control

GFSK/FSK receive mode is enabled by setting Register rc_cfg, Field rc_mode = 3 (0x13E[7:0]). See the SPORT Interface section for details. Figure 95 shows the timing and control sequence for GFSK/FSK SPORT mode. Figure 96 shows the timing and control sequence for GFSK/FSK packet mode.

In order for the RC_READY interrupt to be generated at the correct time, Register delaycfg2, Field mac_delay_ext must be set to 0x76 (472 μ s). If this value is set, the total MAC delay in GFSK/FSK receive mode is 664 μ s. For applications requiring fast turnaround times, it is recommended that Register delaycfg2, Field mac_delay_ext be set to 0x00. In this case, the RC_READY interrupt should be ignored because the calibration time is still 664 μ s.

Following the receiver MAC delay, the transceiver enters the RX state. The transceiver starts to search for a valid preamble/sync word. If enabled, an rx_sfd interrupt is asserted when a preamble followed by the correct sync word has been received. In GFSK/FSK SPORT mode, the framing signal appearing on the IRQ2_TRFS_GP2 output provides more accurate timing information than the rx_sfd interrupt and no rx_pkt_rcvd interrupt is generated. A command to enter an alternative state must be issued to exit the RX state.

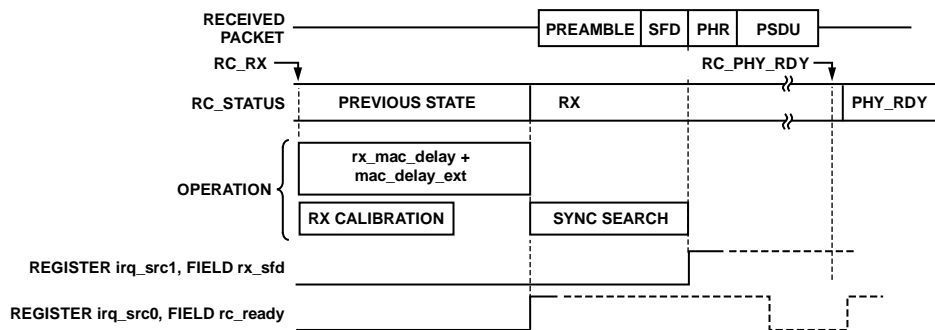

Figure 95. RX Timing and Control GFSK/FSK SPORT Mode

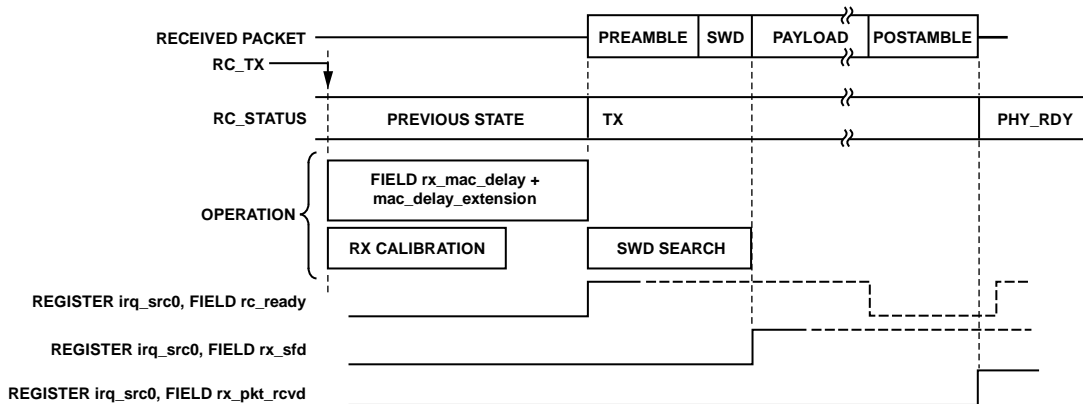

Figure 96. RX Timing and Control GFSK/FSK Packet Mode

RECEIVER RADIO BLOCKS

Baseband Filter

Baseband filtering on the ADF7242 is accomplished by a cascade of analog and digital filters. The single-sided 3 dB bandwidth of the analog baseband filter is programmable from 555 kHz to 1126 kHz through Register `rxfe_cfg`, Field `rxbb_bw_ana` (0x39B[3:0]). The bandwidth of the digital filter can be set with Register `iirf_cfg`, Field `iir_stage1_bw` (0x389[1:0]) and Register `iirf_cfg`, Field `iir_stage2_bw` (0x389[4:2]). The recommended settings for these registers given in the Device Configuration section are based on the modulation parameters shown in Table 22 in the Transmitter section. These settings assume a crystal frequency tolerance of ± 20 ppm for GFSK/FSK mode and ± 40 ppm for IEEE 802.15.4-2006 mode. Any changes in Register `rxfe_cfg`, Field `rxbb_bw_ana` take effect only upon transition from the idle to the PHY_RDY state. Table 32 shows example bandwidths for the analog and digital filters.

Offset Correction Loop (OCL)

The ADF7242 is equipped with a fast and autonomous offset correction loop (OCL), which cancels both static and dynamic time-varying offset voltages present in the zero-IF receiver path. In IEEE 802.15.4 mode, the OCL operates continuously and is not constrained by the formatting, timing, or synchronization of the data being received. In GFSK/FSK mode, the OCL is active only during the receive path calibration phase. After minimizing the offset voltage, the OCL is automatically frozen until the next RC_RX command is issued. This scheme allows the ADF7242 to maintain its RF sensitivity independent of any data formatting constraints in the GFSK/FSK mode. The scheme is also suitable for fast hopping spread-spectrum (FHSS) communication systems. However, because the offset voltages in the receive path are subject to drift over time, there is an upper limit on the channel dwell time. When operating in GFSK/FSK mode, it is recommended to re-issue the RC_RX command at least every 400 ms. It is recommended to use the values listed in the Device Configuration section for the configuration registers pertaining to the offset correction loop.

Table 32. Analog and Digital Filter Parameters

Analog Filter		Digital Filter		
Register <code>rxfe_cfg</code> , Field <code>rxbb_bw_ana</code> (0x39B[3:0])	One-Sided 3 dB Bandwidth (kHz)	Register <code>iirf_cfg</code> , Field <code>iir_stage1_bw</code> (0x389[1:0])	Register <code>iirf_cfg</code> , Field <code>iir_stage2_bw</code> (0x389[4:2]).	One-Sided 3 dB Bandwidth (kHz)
14	1126	2	2	480
14	1086	2	3	320
13	1029	2	4	260
12	991			
11	927			
10	867			
9	797			
8	730			
7	655			
6	555			

Automatic Gain Control (AGC) and Receive Signal Strength Indicator (RSSI)

The ADF7242 AGC circuit features fast overload recovery using dynamic bandwidth adjustments for fast preamble acquisition and optimum utilization of the dynamic range of the receiver path. The radio controller automatically enables the AGC after an offset correction phase, which is carried out when the transceiver enters the RX state. The optimum AGC configuration parameters depend on the selected data rate, the modulation format, and the configuration of the receiver offset correction loop. The recommended settings for the AGC configuration registers based on the modulation parameters, shown in Table 22, are given in the Device Configuration section.

In GFSK/FSK mode, it is possible to lock the AGC and prevent further gain updates after the reception of the preamble using Register `fsk_preamble_config`, Field `fsk_agc_lock_after_preamble`.

The RSSI readback value is continuously updated while the ADF7242 is in the RX state. The result is provided in Register `rrb`, Field `rssi_readback` (0x30C[7:0]) in decibels relative to 1 mW (dBm) using signed twos complement notation. The RSSI averaging window is synchronized with the start of the active RX phase at the end of the MAC delay following an `RC_RX` command. The RSSI averaging time is programmable with Register `agc_cfg5`, Field `rssi_avg_time` (0x3B9[1:0]), and depends on the AGC update rate according to the following formula:

$$T_{avg_rssi} = 77 \text{ ns} \times 2^\alpha$$

where

$$\alpha = 2 + (\text{Register } agc_cfg5, \text{Field } agc_filt2_tavg1) + (\text{Register } agc_cfg6, \text{Field } agc_filt2_tavg2) + (\text{Register } agc_cfg5, \text{Field } rssi_avg_time)$$

In IEEE 802.15.4-2006 mode, the default RSSI averaging period of 128 μ s, or eight symbol periods, must be used for compliance with the IEEE 802.15.4-2006 standard. If the ADF7242 is operating in the IEEE 802.15.4-2006 packet mode, the RSSI of received frames is measured and stored together with the frame in `RX_BUFFER`. The RSSI is measured in a window with a length of eight symbols immediately following the detected SFD. The result is then stored in place of the first byte of the FCS of the received frame in `RX_BUFFER`. For GFSK/FSK mode, the optimum RSSI averaging time is application dependent and the default settings should be appropriate for most applications.

It is also possible to compensate for systematic errors of the measured RSSI value and/or production tolerances by adjusting the RSSI readback value by an offset value that can be programmed in Register `agc_cfg5`, Field `rssi_offs` (0x3B9[4:2]). The adjustment resolution is in 1 dB steps.

SPORT INTERFACE

The SPORT interface is a high speed synchronous serial interface suitable for interfacing to a wide variety of MCUs and DSPs, without the use of glue logic. These include, among others, the ADSP-21xx, SHARC, TigerSHARC and Blackfin DSPs. Figure 116 and Figure 117 show typical application diagrams using one of the available SPORT modes. The interface uses four signals, a clock output (TRCLK_CKO_GP3), a receive data output (DR_GP0), a transmit data input (DT_GP1), and a framing signal output (IRQ2_TRFS_GP2). The IRQ2 output functionality is not available while the SPORT interface is enabled. The SPORT interface supports GFSK/FSK and IEEE 802.15.4 receive and transmit operations. When using GFSK/FSK mode, the polarity of the receive/transmit clock appearing on the TRCLK_CKO_GP3 output is programmable. A detailed overview of the function of the interface pins for each GFSK/FSK mode SPORT configuration is listed in Table 33. The corresponding list for IEEE 802.15.4 mode is listed in Table 34. It is possible to use the SPORT interface for transmitting IEEE 802.15.4 frames by configuring the ADF7242 in 2 Mbps FSK mode (see Device Configuration section) and performing the symbol chipping operation externally.

GFSK/FSK SPORT MODE

GFSK/FSK SPORT Mode Transmit Operation

Figure 97 illustrates the operation of the SPORT interface in the TX state. The SPORT interface is enabled by setting Register gp_cfg, Bit gpio_config = 1 or Bit gpio_config = 4 (0x32C[7:0]) depending on the desired clock polarity. When enabled, the data input of the transmitter is fully controlled by the SPORT interface. The transmit clock appears when the transmit MAC delay (tx_max_delay) has elapsed. The ADF7242 keeps transmitting the serial data presented at the DT_GP1 input until the TX state is exited by means of a command, for example, the RC_PHY_RDY command. A timing diagram GFSK/FSK transmit SPORT mode is provided in Figure 13.

GFSK/FSK SPORT Mode Receive Operation

The SPORT interface supports GFSK/FSK receive operation with a number of modes to suit particular signaling requirements, as shown in Figure 98. For GFSK/FSK receive SPORT operation, set Register rc_cfg, Field rc_mode = 3 (0x13E[7:0]). This disables any packet-level processing by the packet manager. The operating mode of the SPORT interface can be configured through Register gp_cfg, Bit gpio_config (0x32C[7:0]). Table 33 shows an overview of all available configurations. The SPORT mode configurations gpio_config = 2, 3, 5, and 6 in Register gp_cfg provide synchronization with a programmable SWD. For these modes, the synchronization block must be configured with appropriate register writes as

outlined in the GFSK/FSK Packet Mode Reception section, prior to issuing the RC_RX command.

When in SPORT mode, received data continues to appear on the interface pins until the RC_RX command is reissued or the RX state is exited by means of an appropriate SPI command. The following SPORT operating modes can be selected.

Register gp_cfg, Field gpio_config = 1 or

Field gpio_config = 4

The data clock is enabled at the TRCLK_CKO_GP3 output together with the received data at the DR_GP0 output during the receiver MAC delay. The GFSK/FSK SWD is ignored in this configuration. The IRQ2_TRFS_GP2 output has no function. Figure 10 illustrates further timing details.

Register gp_cfg, Field gpio_config = 2 or

Field gpio_config = 5

When a preamble signal has been detected, the data clock and data signals start to appear at the TRCLK_CKO_GP3 and DR_GP0 output, respectively. The IRQ2_TRFS_GP2 output goes HIGH when the sync word has been detected in the received GFSK/FSK bit stream. Figure 11 shows more timing details.

Register gp_cfg, Field gpio_config = 3 or

Field gpio_config = 6

The data clock starts to appear at the TRCLK_CKO_GP3 output when a valid preamble and the SWD have both been detected in the received GFSK/FSK bit stream. The first active clock edge corresponds with the first data bit following the GFSK/FSK SWD appearing on the DR_GP0 output. The framing signal IRQ2_TRFS_GP2 goes high when the SWD has been detected in the received bit sequence. The DR_GP0 output signal should be ignored prior to the first active clock edge appearing on the TRCLK_CKO_GP3 output. Figure 12 illustrates the applicable timing details.

SWD and Preamble in GFSK/FSK SPORT Mode

To configure GFSK/FSK SPORT mode, set Register rc_cfg, Field rc_mode = 3 (0x13E[7:0]). The preamble length requirements and tolerance options described in the GFSK/FSK Packet Mode section also apply for SPORT mode. The ADF7242 can also support automatic detection of a SWD in SPORT mode. The ADF7242 SWD detection algorithm as described in the GFSK/FSK Packet Mode Reception section applies. There are a number of clock and data gating options available. Options include gating received data on preamble, or SWD detection. Refer to Table 33 for further details.

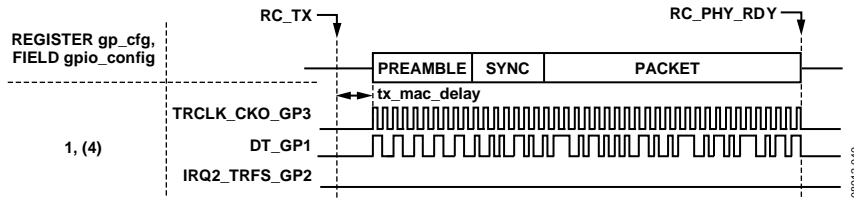

Figure 97. SPORT Operation in GFSK/FSK TX State

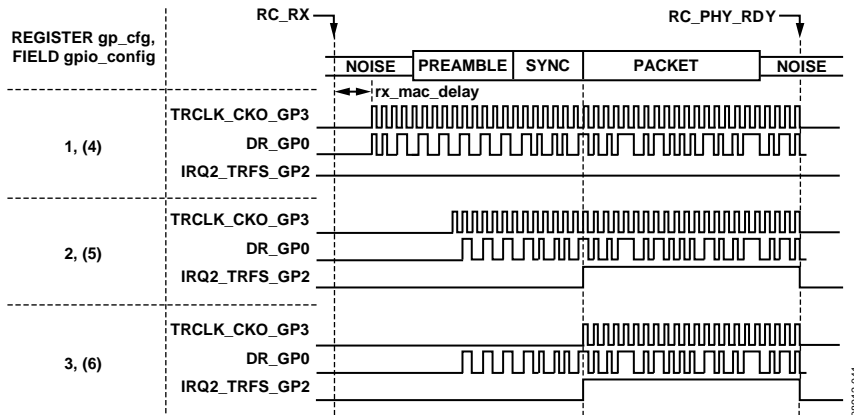

Figure 98. Overview of SPORT Modes in GFSK/FSK RX State

Table 33. GFSK/FSK Mode SPORT Interface Configurations

Register gp_cfg, Bit gpio_config	IRQ2_TRFS_GP2	DR_GP0	DT_GP1	TRCLK_CKO_GP3
1	RX: not used, low TX: not used, low	RX: data output, changes at falling edge of data clock TX: not used	RX: not used TX: data input, sampled at rising edge of data clock	RX: data clock TX: data clock
2	RX: goes high when sync match has been detected	RX: data output, changes at falling edge of data clock	RX: not used	RX: data clock, gated with detection of preamble
3	RX: goes high when sync match has been detected	RX: data output, changes at falling edge of data clock	RX: not used	RX: data clock, gated with detection of sync word
4	RX: not used, low TX: not used, low	RX: data output, changes at rising edge of data clock TX: not used	RX: not used TX: data input, sampled at falling edge of data clock	RX: data clock TX: data clock
5	RX: goes high when sync match has been detected	RX: data output, changes at rising edge of data clock	RX: not used	RX: data clock, gated with detection of preamble
6	RX: goes high when sync match has been detected	RX: data output, changes at rising edge of data clock	RX: not used	RX: data clock, gated with detection of sync word

IEEE 802.15.4-2006 SPORT MODE

IEEE 802.15.4-2006 SPORT Mode Receive Operation

The ADF7242 provides an IEEE 802.15.4-2006 operating mode in which the SPORT interface is active and the packet manager is bypassed. It allows the reception of packets of arbitrary length. The mode is enabled by setting Register rc_cfg, Field rc_mode = 2 (0x13E[7:0]) and Register gp_cfg, Field gpio_config = 1 (0x32C[7:0]). When the SFD is detected, data and clock signals appear on the SPORT outputs, DR_GP0 and TRCLK_CKO_GP3, respectively. The SPORT interface remains active until an RC_RX command is reissued or the RX state is exited by another command. The rx_pkt_rvcd interrupt is not available in this mode. Figure 7 illustrates the timing for this configuration. Refer to Table 34 for details of pins relevant to the SPORT interface in IEEE 802.15.4-2006 mode.

Receive Symbol Clock in IEEE 802.15.4-2006 SPORT Mode

The ADF7242 offers a symbol clock output option during IEEE 802.15.4 packet reception. This option is useful when a tight

timing synchronization between incoming packets and the network is required, and the SFD interrupt (rx_sfd) cannot be used to achieve this. When in IEEE 802.15.4-2006 packet mode (Register rc_cfg, Field rc_mode = 0), set Register gp_cfg, Field gpio_config = 7 (0x32C[7:0]) to enable the symbol clock output.

IEEE 802.15.4-2006 SPORT Mode Transmit Operation

IEEE 802.15.4-2006 TX SPORT mode is enabled by setting Register rc_cfg, Field rc_mode = 3. It is necessary for the host MCU to perform the IEEE 802.15.4 chipping sequence in this mode. The data, sent through the SPORT interface on Pin DT_GP1, should be synchronized with the clock signal that appears on Pin TRCLK_CKO_GP3. Figure 9 shows the timing for this configuration. As in GFSK/FSK TX SPORT mode, the polarity of this clock signal can be set by Register gp_cfg, Field gpio_config. The tx_pkt_sent interrupt is not available in this mode. See Table 34 for details of pins relevant to this SPORT mode.

Table 34. IEEE 802.15.4 Mode SPORT Interface Configuration

Register gp_cfg, Field gpio_config	Register rc_cfg, Field rc_mode	IRQ2_TRFS_GP2	DR_GP0	DT_GP1	RXEN_GP5	RXEN_GP6	TRCLK_CKO_GP3
3	2	RX: ignore	RX: data output, changes at rising edge of data clock	RX: ignore	RX: ignore	RX: ignore	RX: data clock
7	2	RX: ignore	RX: Symbol 0	RX: Symbol 1	RX: Symbol 2	RX: Symbol 3	RX: symbol clock
1	3	TX: ignore	TX: ignore	TX: data input, sampled at rising edge of data clock	TX: ignore	TX: ignore	TX: data clock
4	3	TX: ignore	TX: ignore	TX: data input, sampled at falling edge of data clock	TX: ignore	TX: ignore	TX: data clock

ADF7242

DEVICE CONFIGURATION

After a cold start, or wake-up from sleep, it is necessary to configure the ADF7242. The device can be configured in four primary ways: an IEEE 802.15.4-2006 packet mode, an IEEE 802.15.4-2006 SPORT mode, and GFSK/FSK packet and GFSK/FSK SPORT modes. Registers applicable to the set-up each of the four primary modes are detailed in Table 35.

Table 36 through to Table 42 detail the values that should be written to the register locations given in Table 35 to configure the ADF7242 in the desired mode of operation.

If it is desired to transition from a GFSK/FSK mode to an IEEE.802.15.4-2006 mode, or vice-versa, it is necessary to first issue the RC_RESET command.

Table 35. Register Writes Required to Configure the ADF7242

Register Group Description	Register(s)	IEEE 802.15.4 Packet Mode	IEEE 802.15.4 SPORT Mode	FSK Packet Mode	FSK SPORT Mode
RFIO Port	0x39B	Yes	Yes	Yes	Yes
Packet/SPORT Mode Selection	0x13E			Yes	Yes
SPORT Mode Configuration	0x32C		Yes		Yes
Sync Word	0x10C, 0x10D, 0x10E, 0x3F4 ¹	Yes ¹	Yes ¹	Yes	Yes
Sync Word Configuration	0x10F			Yes	Yes
Number of Preamble Bytes to Transmit	0x102			Yes	
Number of Preamble Validation Bytes	0x3F3 ²			Yes	
Data Rate	0x30E, 0x30F			Yes	Yes
Frequency Deviation	0x304			Yes	Yes
Discriminator BW	0x305			Yes	Yes
Postdemodulation BW	0x38B			Yes	Yes
Digital Filter Settings	0x389			Yes	Yes
Transmit Filters	0x306		Yes	Yes	Yes
Analog Filter BW	0x39B			Yes	Yes
Synthesizer Lock Time	0x335			Yes	Yes
AGC	0x3B4, 0x3B6, 0x3B7, 0x3B8, 0x3BA, 0x3BC			Yes	Yes
AGC Lock	0x3B2			Yes	Yes
OCL	0x3BF, 0x3C4, 0x3D2, 0x3D3, 0x3D4, 0x3D5, 0x3D6, 0x3D7, 0x3E0			Yes	Yes
AFC	0x3F8, 0x3F9			Yes	Yes
AFC Lock	0x3F7			Yes	Yes

¹ These apply only when the user wishes to program a nonstandard SFD.

² This register should only be written to in GFSK/FSK packet mode because the default setting of 0x05 is used in IEEE 802.15.4 packet mode.

CONFIGURATION VALUES COMMON TO IEEE 802.15.4 AND GFSK/FSK MODES

If it is desired to use RF Port 1 rather than RF Port 2 (see the RF Port Configurations/Antenna Diversity section), the value specific to the desired operating mode given in Table 36 should be written to the relevant register field.

Table 36. Settings Required to Select Between LNA Port 1 and LNA Port 2

Address	Register Field	Value
0x39B [6:4]	rxfe_cfg, lna_sel	0x0: LNA1 0x1: LNA2

CONFIGURATION VALUES FOR GFSK/FSK PACKET AND SPORT MODES

If it is desired to use either GFSK/FSK packet or SPORT mode, the host MCU should write the configuration values shown in Table 37 to the given register locations. These are common to all GFSK/FSK packet and SPORT modes. Depending on the desired data rate, the relevant values from Table 38 should also be written.

Table 37. Settings Common to All GFSK/FSK Configurations

Address	Register Name	Value
0x335	synt	0x28
0x3B2	agc_cfg1	0x34
0x3B4	agc_max	0x80
0x3B6	agc_cfg2	0x37
0x3B7	agc_cfg3	0x2A
0x3B8	agc_cfg4	0x1D
0x3BA	agc_cfg6	0x24
0x3BC	agc_cfg7	0x7B
0x3BF	ocl_cfg0	0x00
0x3C4	ocl_cfg1	0x07
0x3D2	ocl_bw0	0x1A
0x3D3	ocl_bw1	0x19
0x3D4	ocl_bw2	0x1E
0x3D5	ocl_bw3	0x1E
0x3D6	ocl_bw4	0x1E
0x3D7	ocl_bws	0x00
0x3E0	ocl_bw13	0xF0
0x3F3	preamble_num_validate	0x01

Table 38. Data Rate-Specific GFSK/FSK Settings

Address	Register or Field Name	50 kbps FSK	62.5 kbps FSK	100 kbps FSK	125 kbps FSK	250 kbps GFSK	500 kbps GFSK	1 Mbps GFSK	2 Mbps GFSK
0x102 ¹	fsk_preamble	0x04 (6 bytes)	0x04 (6 bytes)	0x05 (7 bytes)	0x05 (7 bytes)	0x05 (7 bytes)	0x05 (7 bytes)	0x07 (9 bytes)	0x09 (11 bytes)
0x304	tx_fd	0x03	0x06	0x03	0x06	0x0D	0x19	0x19	0x32
0x305	dm_cfg0	0x37	0x37	0x6B	0x37	0x19	0x0D	0x0D	0x06
0x306	tx_m	0x00	0x00	0x00	0x00	0x02	0x03	0x03	0x03
0x30E	dr0	0x01	0x02	0x03	0x04	0x09	0x13	0x27	0x4E
0x30F	dr1	0xF4	0x71	0xE8	0xE2	0xC4	0x88	0x10	0x20
0x389	lirf_cfg	0x17	0x17	0x17	0x17	0x12	0x0A	0x05	0x05
0x38B	dm_cfg1	0x08	0x08	0x0D	0x11	0x20	0x3D	0x6E	0xAA
0x39B [3:0]	rxfe_cfg, rxbb_bw_ana	0x6	0x6	0x6	0x6	0x6	0x6	0x6	0xD

¹ This register should be written to in GFSK/FSK packet mode only. The preamble length transmitted that is given in this table is correct for the values of Register preamble_num_validate given in Table 37 and Register sync_config given in Table 40, where sync_word0 is padded with one byte of preamble. Refer to the Transmitter in GFSK/FSK Mode section for details.

ADF7242

To select between packet mode and SPORT mode for GFSK/FSK, write the values given in Table 39.

Table 39. Settings for GFSK/FSK Packet and SPORT Modes

Address	Register Name	Packet Mode	SPORT Mode
0x13E	rc_cfg	0x04	0x03
0x32C	gp_cfg	N/A	Refer to Table 33

Table 40 gives recommended sync word configuration values. In this example, the sync word length is set to 16 bits so that the sync word will be 0x7F31. Any bits in the sync_word0, sync_word1, or sync_word2 register that are excluded by the setting in sync_len must be filled with preamble pattern. Refer to the Receiver in GFSK/FSK Mode section of the datasheet for details.

Table 40. Example Sync Word Configuration for GFSK/FSK

Address	Register or Field Name	Value	Comment
0x10C	sync_word0	0x31	Sync word is fully programmable.
0x10D	sync_word1	0x7F	Sync word is fully programmable.
0x10E	sync_word2	0xAA	Sync word is fully programmable.
0x10F[6:5]	sync_config, sync_tol	0x0	A sync word tolerance of 0 errors is recommended.
0x10F [4:0]	sync_config, sync_len	0x10	This should match the desired sync word set in Register 0x10C to Register 0x10E.

To enable the AFC, write the values given in Table 41.

Table 41. AFC Configuration Settings for GFSK/FSK

Address	Register Name	Value	Comment
0x3F7	afc_cfg	0x07	By default, AFC is locked on preamble detection.
0x3F8	afc_ki_kp	0x99	Default AFC ki and kp values.
0x3F9	afc_range	0x50	The AFC pull-in range is programmable. Here it is set to ± 80 kHz.

CONFIGURATION VALUES FOR IEEE 802.15.4-2006 PACKET AND SPORT MODES

No register writes are required to configure IEEE 802.15.4 packet mode unless it is desired to select RF Port 1 rather than RF Port 2. For SPORT mode, the values detailed in Table 42 should be written to the ADF7242.

Table 42. IEEE 802.15.4 Configuration Settings

Address	Register Name	Packet Mode	SPORT Mode
0x13E	rc_cfg	N/A	See Table 34
0x306	tx_m	N/A	0x01
0x32C	gp_cfg	N/A	See Table 34

Note that, if it is desired to use a nonstandard SFD, an additional register write is required. Refer to the IEEE 802.15.4-2006 Programmable SFD section for details.

RF PORT CONFIGURATIONS/ANTENNA DIVERSITY

ADF7242 is equipped with two fully differential RF ports. Port 1 is capable of receiving, whereas Port 2 is capable of receiving or transmitting. RF Port 1 comprises Pin RFIO1P and Pin RFIO1N, and RF Port 2 comprises Pin RFIO2P and Pin RFIO2N. Only one of the two RF ports can be active at any one time.

The availability of two RF ports facilitates the use of switched antenna diversity and results in a simplified application circuit if the ADF7242 is connected to an external LNA and/or PA. Port selection for receive operation is configured through Register rxfe_cfg, Field lna_sel (0x39B[6:4]).

Configuration A

Configuration A of Figure 99, is the default connection, where a single antenna is connected to RF Port 2. This selection is made by setting Register rxfe_cfg, Field lna_sel = 1 (default setting).

Configuration B

Configuration B shows a dual-antenna configuration that is suitable for switched antenna diversity. In this case, the link margin can be maximized by comparing the RSSI level of the signal received on each antenna and thus selecting the optimum antenna. In addition, for IEEE 802.15.4-2006 mode the SQI value in Register lrb, Field sqi_readback can be used in the antenna selection decision.

Suitable algorithms for the selection of the optimum antenna depend on the particulars of the underlying communication system. Switching between two antennas is likely to cause a short interruption of the received data stream. Therefore, it is

advisable to synchronize the antenna selection phase with the preamble component of the packet. In a static communication system, it is often sufficient to select the optimum antenna once.

Configuration C

Configuration C shows that connecting an external PA and/or LNA is possible with a single external receive/transmit switch. The PA transmits on RF Port 2. RF Port 1 is configured as the receive input (Register rxfe_cfg, Field lna_sel = 0).

ADF7242 provides two signals, RXEN_GP6 and TXEN_GP5, to automatically enable an external LNA and/or a PA. If Register ext_ctrl, Bit txen_en = 1, the ADF7242 outputs a logic high level at the TXEN_GP5 pin while in TX state, and a logic low level while in any other state. If Register ext_ctrl, Bit rxen_en = 1, the ADF7242 outputs a logic high level at the RXEN_GP6 pin while in RX state and a logic low level while in any other state.

The RXEN_GP6 and TXEN_GP5 outputs have high impedance in the sleep state. Therefore, appropriate pull-down resistors must be provided to define the correct state of these signals during power-down. See the PA Ramping Controller section for further details on the use of an external PA, including details of the integrated biasing block, which simplifies connection to PA circuits based upon a single FET.

Configuration D

Configuration D is similar to Configuration A, except that a dipole antenna is used. In this case, a balun is not required.

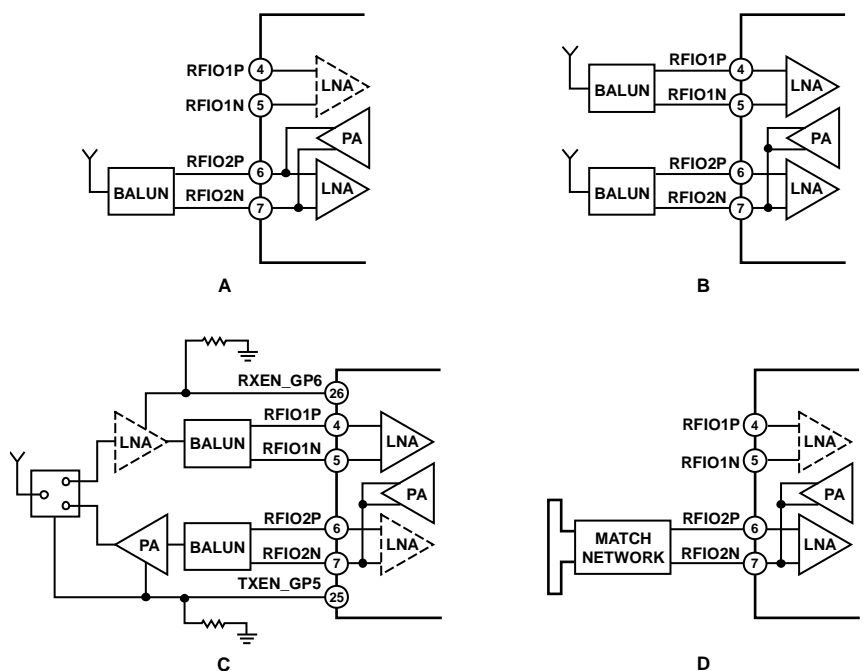

Figure 99. RF Interface Configuration Options (A: Single Antenna; B: Antenna Diversity; C: External LNA/PA; D: Dipole Antenna)

AUXILLARY FUNCTIONS

TEMPERTURE SENSOR

To perform a temperature measurement, the MEAS state is invoked using the RC_MEAS command. The result can be read back from Register `adc_rbk`, Field `adc_out` (0x3AE[5:0]). Averaging multiple readings improves the accuracy of the result. The temperature sensor has an operating range from -40°C to $+85^{\circ}\text{C}$.

The die (ambient) temperature is calculated as follows:

$$t_{die} = (4.72^{\circ}\text{C} \times \text{Register } adc_rbk, \text{Field } adc_out) + 65.58^{\circ}\text{C} + \text{correction value.}$$

where *correction value* can be determined by performing a readback at a single known temperature. Note also that averaging a number of ADC readbacks can improve the accuracy of the temperature measurement.

BATTERY MONITOR

The battery monitor features very low power consumption and can be used in any state other than the sleep state. The battery monitor generates a `batt_alert` interrupt for the host MCU when the battery voltage drops below the programmed threshold voltage. The default threshold voltage is 1.7 V, and can be increased in 62 mV steps to 3.6 V with Register `bm_cfg`, Field `battmon_voltage` (0x3E6[4:0]).

WAKE-UP CONTROLLER (WUC)

Circuit Description

The ADF7242 features a 16-bit wake-up timer with a programmable prescaler. The 32.768 kHz RC oscillator or the 32.768 kHz external crystal provides the clock source for the timer. This tick rate clocks a 3-bit programmable prescaler whose output clocks a pre-loadable 16-bit down counter. An overview of the timer circuit is shown in Figure 100 lists the possible division rates for the prescaler. This combination of programmable prescaler and 16-bit down counter gives a total WUC range of 30.52 μs to 36.4 hours.

Table 43. Prescaler Division Factors

timer_prescal (0x316[2:0])	32.768 kHz Divider	Tick Period
000	1	30.52 μs
001	4	122.1 μs
010	8	244.1 μs
011	16	488.3 μs
100	128	3.91 ms
101	1024	31.25 ms
110	81,92	250 ms
111	65,536	2000 ms

An interrupt generated when the wake-up timer has timed out can be enabled in Register `irq1_en0` or Register `irq2_en0`.

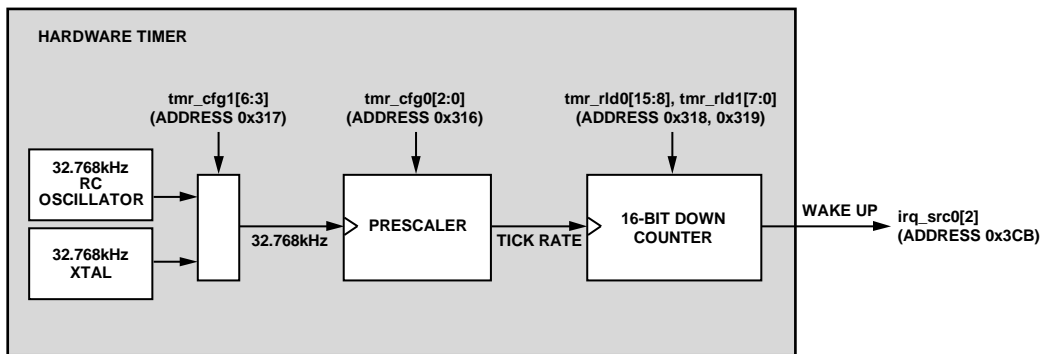

Figure 100. Hardware Wake-Up Timer Diagram

08912-042

WUC Configuration and Operation

The wake-up timer can be configured as follows:

- The clock signal for the timer is taken from the external 32.768 kHz crystal or the internal RC oscillator. This is selectable via Register `tmr_cfg1`, Bit `sleep_config` (0x317[6:3]).
- A 3-bit prescaler, which is programmable via Register `tmr_cfg0`, Bit `timer_prescal` (0x316[2:0]) determines the tick period.

This is followed by a preloadable 16-bit down counter. After the clock is selected, the reload value for the down counter (`tmr_rld0` and `tmr_rld1`) and the prescaler values (Register `tmr_cfg0`, Bit `timer_prescal`) can be programmed. When the clock has been enabled, the counter starts to count down at the tick rate starting from the reload value. If wake-up interrupts are enabled, the timer unit generates an interrupt when the timer value reaches 0x0000. When armed, the wake-up interrupt triggers a wake-up from sleep.

The reliable generation of wake-up interrupts requires the WUC timeout flag to be reset immediately after the reload value has been programmed. To do this, first write 1 and then write 0 to Register `tmr_ctrl`, Field `wake_timer_flag_reset`. To enable automatic wake-up from the sleep state, arm the timer unit for wake-up operation by writing 1 to Register `tmr_cfg1`, Field `wake_on_timeout`. After writing this sequence to the ADF7242, a sleep command can be issued.

Calibrating the RC oscillator

The RC oscillator is not automatically calibrated. If it is desired to use the RC oscillator as the clock source for the WUC, the host MCU should initiate a calibration. This can be performed at any time in advance of entering the sleep state. To perform a calibration, the host MCU should

- Set Register `tmr_ctrl`, Field `wuc_rc_osc_cal` = 0
- Set Register `tmr_ctrl`, Field `wuc_rc_osc_cal` = 1

The calibration time is typically 1 ms. When the calibration is complete Register `wuc_32khzosc_status`, Field `rc_osc_cal_ready` is high. Following calibration, the host MCU can transition to the `SLEEP_BBRAM_RCO` sleep state, by following the full procedure given in the WUC Configuration and Operation section.

TRANSMIT TEST MODES

The ADF7242 has various transmit test modes that can be used in IEEE 802.15.4-2006 and GFSK/FSK SPORT modes. These test modes can be enabled by writing to Register `tx_fsk_test` (Location 0x3F0), as described in Table 44. A continuous packet transmission mode is also available in IEEE 802.15.4-2006 and GFSK/FSK packet modes. This mode can be enabled using the following procedure:

1. An IEEE 802.15.4-2006 or a GFSK/FSK packet with random payload should be written to `TX_BUFFER` as described in the Transmitter section. It is recommended to use a packet with the maximum length of 127 bytes.
2. Set Register `buffercfg`, Field `trx_mac_delay` = 1.
3. Set Register `buffercfg`, Field `tx_buffer_mode` = 3.
4. Set Register `pkt_cfg`, Field `skip_synth_settle` = 1.
5. Issue Command `RC_TX`. The transmitter continuously transmits the packet stored in `TX_BUFFER`.
6. If Command `RC_PHY_RDY` is issued at any point after this step, all the preceding configuration registers must be rewritten to the device before reissuing Command `RC_TX`.

Note that the transmitter momentarily transmits an RF carrier between packets due to a finite delay from when the packet handler finishes transmitting a packet in `TX_BUFFER` and going back to transmit the start of `TX_BUFFER` again.

Table 44. 0x3F0: `tx_fsk_test`

Bit	Name	R/W	Reset Value	Description
[7:4]	Reserved	R/W	2	Reserved, set to default.
3	zero_only	R/W	0	Transmit 0 only ($f_{CH} - f_{DEV}$) in GFSK/FSK sport mode.
2	one_only	R/W	0	Transmit 1 only ($f_{CH} + f_{DEV}$) in GFSK/FSK sport mode.
1	carrier_only	R/W	0	Transmits unmodulated tone at the programmed frequency f_{CH} .
0	Reserved	R/W	0	Reserved, set to default.

SERIAL PERIPHERAL INTERFACE (SPI)

GENERAL CHARACTERISTICS

The ADF7242 is equipped with a 4-wire SPI interface, using the SCLK, MISO, MOSI, and $\overline{\text{CS}}$ pins. The ADF7242 always acts as a slave to the host MCU. Figure 101 shows an example connection diagram between the host MCU and the ADF7242. The diagram also shows the direction of the signal flow for each pin. The SPI interface is active and the MISO output enabled only while the $\overline{\text{CS}}$ input is low. The interface uses a word length of eight bits, which is compatible with the SPI hardware of most microprocessors. The data transfer through the SPI interface occurs with the most significant bit of address and data first. Refer to Figure 3 for the SPI interface timing diagram. The MOSI input is sampled at the rising edge of SCLK. As commands or data are shifted in from the MOSI input at the SCLK rising edge, the status word or data is shifted out at the MISO pin synchronous with the SCLK clock falling edge. If $\overline{\text{CS}}$ is brought low, the most significant bit of the status word appears on the MISO output without the need for a rising clock edge on the SCLK input.

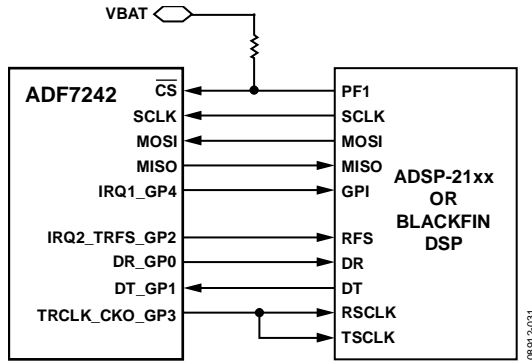

Figure 101. SPI Interface Connection

COMMAND ACCESS

The ADF7242 is controlled through commands. Command words are single-byte instructions that control the state transitions of the radio controller and access to the registers and packet RAM. The complete list of valid commands is given in Table 45. Commands with the RC prefix are handled by the radio controller, whereas memory access commands, which have the SPI prefix are handled by an independent controller. Thus, SPI commands can be issued independent of the state of the radio controller.

A command is initiated by bringing $\overline{\text{CS}}$ low and shifting in the command word over the SPI as shown in Figure 102.

All commands are executed after $\overline{\text{CS}}$ goes high again or at the next positive edge of the SCLK input. The latter condition occurs in the case of a memory access command. In this case, the command is executed on the positive SCLK clock edge corresponding to the most significant bit of the first parameter word. The $\overline{\text{CS}}$ input must be brought high again after a command has been shifted into the ADF7242 to enable the recognition of successive command words. This is because a single command can be issued only during a $\overline{\text{CS}}$ low period (with the exception of a double NOP command).

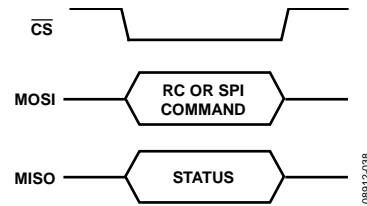

Figure 102. Command Write

The execution of certain commands by the radio controller may take several instruction cycles, during which the radio controller unit is busy. Prior to issuing a radio controller command, it is, therefore, necessary to read the status word to determine if the ADF7242 is ready to accept a new radio controller command. This is best accomplished by shifting in SPI_NOP commands, which cause status words to be shifted out. The RC_READY variable is used to indicate when the radio controller is ready to accept a new RC command, whereas the SPI_READY variable indicates when the memory can be accessed. To take the burden of repeatedly polling the status word off the host MCU for complex commands such as RC_RX, RX_TX, and RC_PHY_RDY, the IRQ handler can be configured to generate an RC_READY interrupt. See the Interrupt Controller section for details. Otherwise, the user can program timeout periods according to the command execution times provided under the state transition timing given in Table 10 and Table 11.

STATUS WORD

The status word of the ADF7242 is automatically returned over the MISO each time a byte is transferred over the MOSI. The meaning of the various status word bit fields is illustrated in Table 46. The RC_STATUS field reflects the current state of the radio controller. By definition, RC_STATUS reflects the state of a completed state transition. During the state transition, RC_STATUS maintains the value of the state from which the state transition was invoked.

Table 45. Command List

Command	Code	Description
SPI_NOP	0xFF	No operation. Use for dummy writes.
SPI_PKT_WR	0x10	Write data to the packet RAM starting from the transmit packet base address pointer, Register txpb, Field tx_pkt_base (0x314[7:0]).
SPI_PKT_RD	0x30	Read data from the packet RAM starting from the receive packet base address pointer, Register rxpb, Field rx_pkt_base (0x315[7:0]).
SPI_MEM_WR	0x18 + memory address[10:8]	Write data to MCR or packet RAM sequentially.
SPI_MEM_RD	0x38 + memory address[10:8]	Read data from MCR or packet RAM sequentially.
SPI_MEMR_WR	0x08 + memory address[10:8]	Write data to MCR or packet RAM as a random block.
SPI_MEMR_RD	0x28 + memory address[10:8]	Read data from MCR or packet RAM as a random block.
SPI_PRAM_WR	0x1E	Write data to the program RAM.
RC_SLEEP	0xB1	Invoke transition of the radio controller into the sleep state
RC_IDLE	0xB2	Invoke transition of the radio controller into the idle state
RC_PHY_RDY	0xB3	Invoke transition of the radio controller into the PHY_RDY state
RC_RX	0xB4	Invoke transition of the radio controller into the RX state
RC_TX	0xB5	Invoke transition of the radio controller into the TX state
RC_MEAS	0xB6	Invoke transition of the radio controller into the MEAS state
RC_CCA	0xB7	Invoke clear channel assessment
RC_PC_RESET	0xC7	Program counter reset. This should only be used after a firmware download to the program RAM
RC_RESET	0xC8	Resets the ADF7242 and puts it in the sleep state

Table 46. SPI Status Word

Bit	Name	Description
7	SPI_READY	0: SPI is not ready for access. 1: SPI is ready for access.
6	IRQ_STATUS	0: no pending interrupt condition. 1: pending interrupt condition. (IRQ_STATUS = 1 when either the IRQ1_GP4 or IRQ2_TRFS_GP2 pin is high)
5	RC_READY	0: radio controller is not ready to accept RC_xx command strobe. 1: radio controller is ready to accept new RC_xx command strobe.
4	CCA_RESULT	0: channel busy. 1: channel idle. Valid when Register irq_src1, Bit cca_complete (0x3CC[0]) is asserted.
[3:0]	RC_STATUS	Radio controller status: 0: reserved. 1: idle. 2: MEAS. 3: PHY_RDY. 4: RX. 5: TX. 6 to 15: reserved.

MEMORY MAP

The various memory locations used by the ADF7242 are shown in Figure 103. The radio control and packet management of the part are realized through the use of an 8-bit, custom processor and an embedded ROM. The processor executes instructions stored in the embedded program ROM. There is also a local RAM, subdivided into three sections, that is used as a data packet buffer, both for transmitted and received data (packet RAM), and for storing the radio and packet management configuration (BBRAM and MCR). The RAM addresses of these variables are 11 bits in length.

BBRAM

The 64-byte battery back-up, or BBRAM, is used to maintain settings needed at wake-up from sleep state by the wake-up controller.

MODEM CONFIGURATION RAM (MCR)

The 256-byte modem configuration RAM, or MCR, contains the various registers used for direct control or observation of the physical layer radio blocks of the ADF7242. Contents of the MCR are not retained in the sleep state.

PROGRAM ROM

The program ROM consists of 4 kB of nonvolatile memory. It contains the firmware code for radio control, packet management, and smart wake mode.

PROGRAM RAM

The program RAM consists of 2 kB of volatile memory. This memory space is used for various software modules, such as address filtering and CSMA/CA, which are available from Analog Devices. The software modules are downloaded to the program RAM memory space over the SPI by the host microprocessor. See the Program RAM Write subsection of the Memory Access section for details on how to write to the program RAM.

PACKET RAM

The packet RAM consists of 256 bytes of memory space from Address 0x000 to Address 0x0FF, as shown in Figure 103. This memory is allocated for storage of data from valid received packets and packet data to be transmitted. The packet manager stores received payload data at the memory location indicated by the value of Register rxpb, Field rx_pkt_base, the receive address pointer. The value of Register txpb, Field tx_pkt_base, the transmit address pointer, determines the start address of data to be transmitted by the packet manager. This memory can be arbitrarily assigned to store single or multiple transmit or receive packets, both with and without overlap as shown in Figure 104. The rx_pkt_base value should be chosen to ensure that there is enough allocated packet RAM space for the maximum receiver payload length.

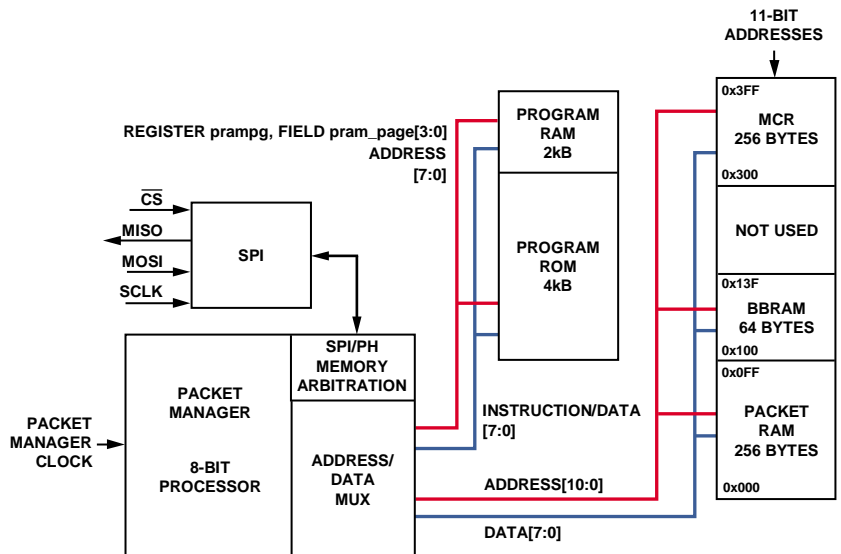

Figure 103. ADF7242 Memory Map

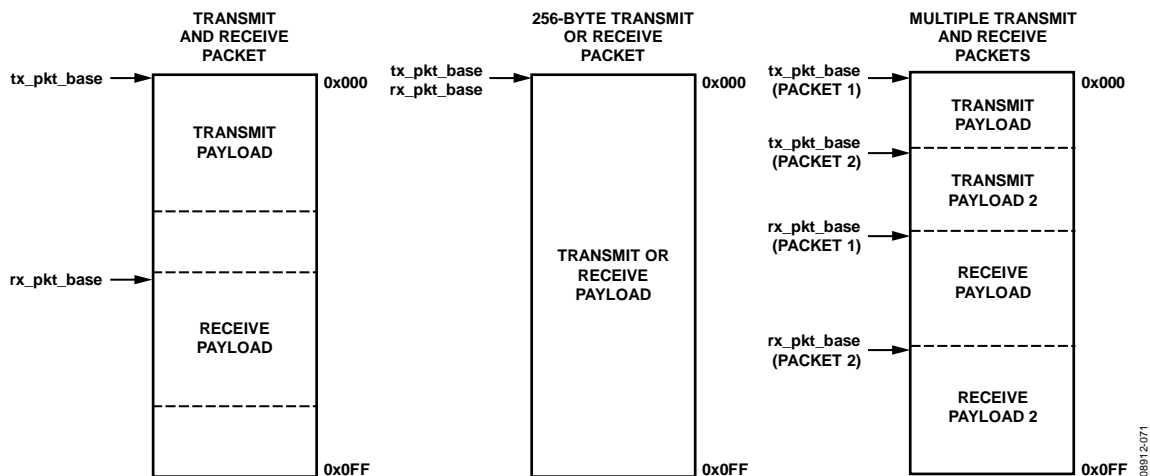

Figure 104. Example Packet RAM Configurations Using the Transmit Packet and Receive Packet Address Pointers

0891.2.071

MEMORY ACCESS

Memory locations are accessed by invoking the relevant SPI command. An 11-bit address is used to identify registers or locations in the memory space. The most significant three bits of the address are incorporated into the command by appending them as the LSBs of the command word. Figure 105 illustrates the command, address, and data partitioning. The various SPI memory access commands are different depending on the memory location being accessed. This is described in Table 47.

An SPI command should be issued only if the SPI_READY bit of the status word is high.

In addition, an SPI command should not be issued while the radio controller is initializing. SPI commands can be issued in any radio controller state including during state transition.

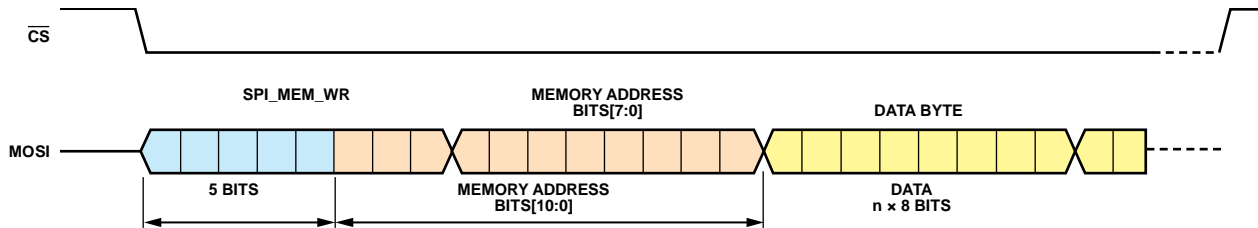

Table 47. Summary of SPI memory access commands

SPI Command	Command Value	Description
SPI_PKT_WR	= 0x10	Write telegram to the packet RAM starting from the transmit packet base address pointer, Register txpb, Field tx_pkt_base (0x314[7:0]).
SPI_PKT_RD	= 0x30	Read telegram from the packet RAM starting from receive packet base address pointer, Register rxpb, Field rx_pkt_base (0x315[7:0]).
SPI_MEM_WR	= 0x18 (packet RAM) = 0x19 (BBRAM) = 0x1B (MCR)	Write data to BBRAM, MCR, or packet RAM sequentially. An 11-bit address is used to identify memory locations. The most significant three bits of the address are incorporated into the command (xxx). This command is followed by the remaining eight bits of the address.
SPI_MEM_RD	= 0x38 (packet RAM) = 0x39 (BBRAM) = 0x3B (MCR)	Read data from BBRAM, MCR, or packet RAM sequentially. An 11-bit address is used to identify memory locations. The most significant three bits of the address are incorporated into the command (xxx). This command is followed by the remaining eight bits of the address, which is subsequently followed by the appropriate number of SPI_NOP commands.
SPI_MEMR_WR	= 0x08 (packet RAM) = 0x09 (BBRAM) = 0x0B (MCR)	Write data to BBRAM/MCR or packet RAM at random.
SPI_MEMR_RD	= 0x28 (packet RAM) = 0x29 (BBRAM) = 0x2B (MCR)	Read data from BBRAM/MCR or packet RAM at random.
SPI_PRAM_WR	= 0x1E (program RAM)	Write data to program RAM.
SPI_PRAM_RD	= 0x3E (program RAM)	Read data from program RAM
SPI_NOP	= 0xFF	No operation. Use for dummy writes when polling the status word and used as dummy data on the MOSI line when performing a memory read.

WRITING TO THE ADF7242

Block Write

Packet RAM memory locations can be written to in block format using the SPI_PKT_WR. The SPI_PKT_WR command is 0x10. This command provides pointer-based write access to the packet RAM. The address of the location written to is calculated from the base address in Register txpb, Field tx_pkt_base (0x314[7:0]) plus an index. The index is zero for the first data word following the command word, and is auto-incremented for each consecutive data word written. The first data word following an SPI_PKT_WR command is thus stored in the location with Address txpb, Field tx_pkt_base (0x314[7:0]), the second in packet RAM location with Address txpb, Field tx_pkt_base + 1, and so on. This feature makes this command efficient for bulk writes of data that recurrently begin at the same address. Figure 106 shows the access sequence for Command SPI_PKT_WR.

The MCR, BBRAM, and packet RAM memory locations can be written to in block format using the SPI_MEM_WR command. The SPI_MEM_WR command code is 00011xxx, where xxxb represent Bits[10:8] of the first 11-bit address. If more than one data byte is written, the write address is automatically incremented for every byte sent until \overline{CS} is set high, which terminates the memory access command. See Figure 107 for more details. The maximum block write for the MCR, packet RAM, and BBRAM memories are 256 bytes, 256 bytes, and 64 bytes, respectively. These maximum block-write lengths should not be exceeded.

Example

Write 0x00 to the rc_cfg register (Location 0x13E).

- The first five bits of the SPI_MEM_WR command are 00011.
- The 11-bit address of rc_cfg is 00100111110.
- The first byte sent is 00011001 or 0x19.
- The second byte sent is 00111110 or 0x3E.
- The third byte sent is 0x00.

Thus, 0x193F00 is written to the part.

Random Address Write

MCR, BBRAM, and packet RAM memory locations can be written to in random address format using the SPI_MEMR_WR command. The SPI_MEMR_WR command code is 00001xxx, where xxxb represent Bits[10:8] of the 11-bit address. The lower eight bits of the address should follow this command and then the data byte to be written to the address. The lower eight bits of the next address are entered followed by the data for that address until all required addresses within that block are written, as shown in Figure 108. Note that the SPI_MEMR_WR command facilitates the modification of individual elements of a packet in RX_BUFFER and TX_BUFFER without the need to download and upload an entire packet.

The address location of a particular byte in RX_BUFFER and TX_BUFFER in the packet RAM is determined by adding the

relative location of a byte to Address Pointer rx_pkt_base (Register rxpb; 0x315[7:0]) or Address Pointer tx_pkt_base (Register txpb; 0x314[7:0]), respectively.

Program RAM Write

The program RAM can only be written to using the memory block write, as illustrated in Figure 109. The SPI_PRAM_WR command is 0x1E. The program RAM is organized in eight pages with a length of 256 bytes each. The code module must be stored in the program RAM starting from Address 0x0000, or Address 0x00 in Page 0. The current program RAM page is selected with Register prampg, Field pram_page (0x313[3:0]). Prior to uploading the program RAM, the radio controller code module must be divided into blocks of 256 bytes commensurate with the size of the program RAM pages. Each 256-byte block is uploaded into the currently selected program RAM page using the SPI_PRAM_WR command. Figure 109 illustrates the sequence required for uploading a code block of 256 bytes to a PRAM page. The SPI_PRAM_WR command code is followed by Address Byte 0x00 to align the code block with the base address of the program RAM page. Figure 110 shows the overall upload sequence. With the exception of the last page written to the program RAM, all pages must be filled with 256 bytes of module code.

READING FROM THE ADF7242

Block Read

Command SPI_PKT_RD provides pointer-based read access from the packet RAM. The SPI_PKT_RD command is 0x30. The address of the location to be read is calculated from the base address in Register rxpb, Field rx_pkt_base plus an index. The index is zero for the first readback word. It is auto-incremented for each consecutive SPI_NOP command. The first data byte following a SPI_PKT_RD command is invalid and should be ignored. Figure 111 shows the access sequence for Command SPI_PKT_RD.

The SPI_MEM_RD command can be used to perform a block read of MCR, BBRAM, and packet RAM memory locations. The SPI_MEM_RD command code is 0011xxx, where xxxb represent Bits[10:8] of the first 11-bit address. This command is followed by the remaining eight bits of the address to be read and then two SPI_NOP commands (dummy byte). The first byte available after writing the address should be ignored, with the second byte constituting valid data. If more than one data byte is to be read, the read address is automatically incremented for subsequent SPI_NOP commands sent. See Figure 112 for more details.

Random Address Read

MCR, BBRAM, and Packet RAM memory locations can be read from in a nonsequential manner using the SPI_MEMR_RD command. The SPI_MEMR_RD command code is 00101xxx, where xxxb represent Bits[10:8] of the 11-bit address. This command is followed by the remaining eight bits of the address to be written and then two SPI_NOP commands (dummy byte).

ADF7242

The data byte from memory is available on the second SPI_NOP command. For each subsequent read, an 8-bit address should be followed by two SPI_NOP commands as shown in Figure 113.

Example

Read the value stored in the rc_cfg register.

- The first five bits of the SPI_MEM_RD command are 00111.
- The 11-bit address of rc_cfg register is 00100111111.
- The first byte sent is 00111001, or 0x39.
- The second byte sent is 00111110, or 0x3E.
- The third byte sent is 0xFF (SPI_NOP).
- The fourth byte sent is 0xFF.

Thus, 0x393EFFFF is written to the part.

The value shifted out on the MISO line while the fourth byte is sent is the value stored in the rc_cfg register.

This allows individual elements of a packet in RX_BUFFER and TX_BUFFER to be read without the need to download the entire packet.

Program RAM Read

The SPI_PRAM_RD command is used to read from the program RAM. This may be performed to verify that a firmware module has been correctly written to the program RAM. Like the SPI_PRAM_WR command, the host MCU must select the program RAM page to read via Register prampg, Field pram_page. Following this, the host MCU may use the SPI_PRAM_RD command to block read the selected program RAM page. The structure of this command is identical to the SPI_MEM_RD command.

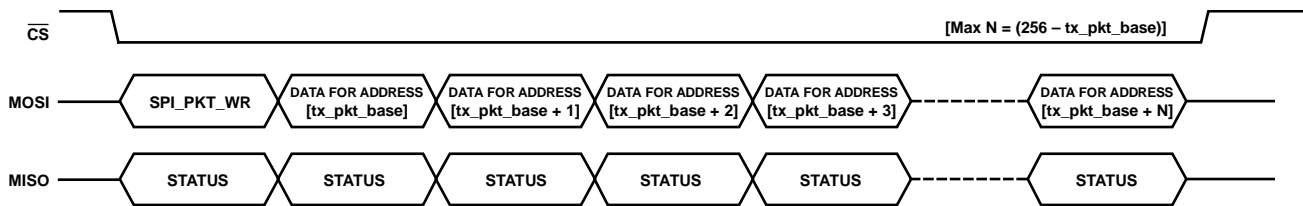

Figure 106. Packet RAM Write

(tx_pkt_base is the address base pointer value for TX, which is programmed in Register txbp, Bit tx_pkt_base.)

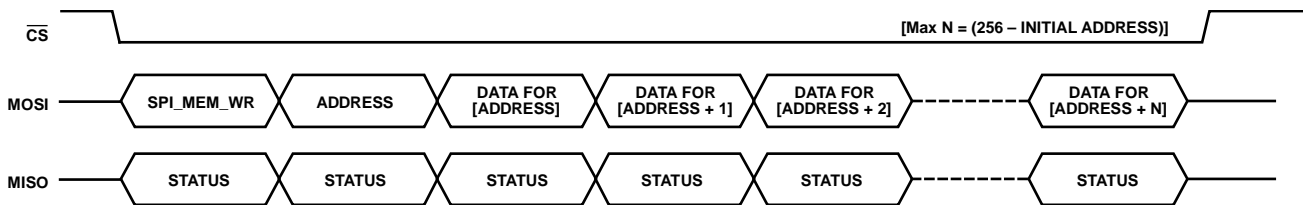

Figure 107. Memory (Register or Packet RAM) Block Write

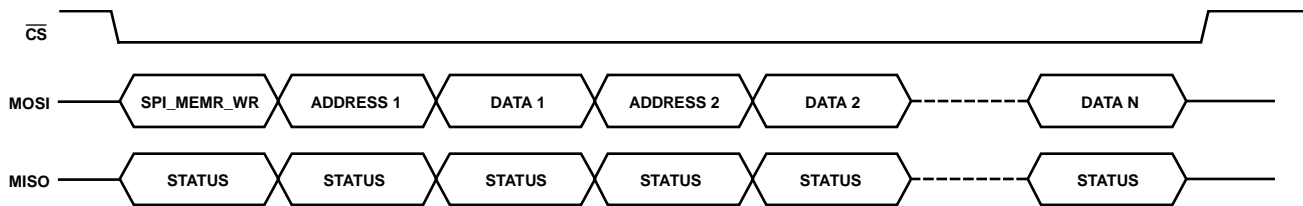

Figure 108. Memory (Register or Packet RAM) Random Address Write

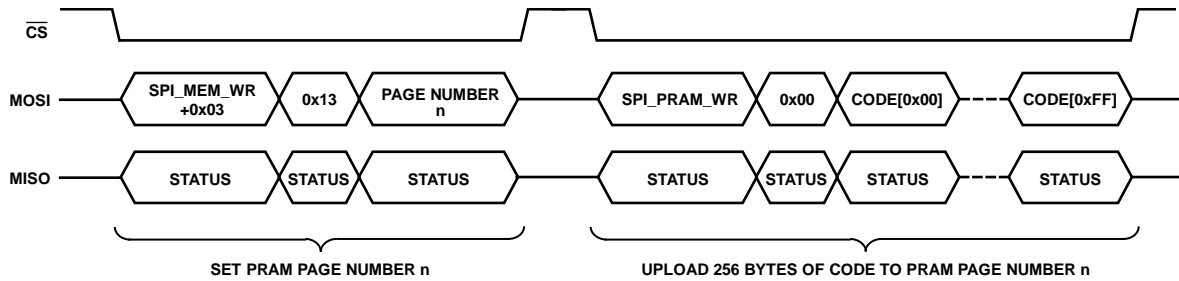

Figure 109. Upload Sequence for a Program RAM Page

08912-073



Figure 110. Download Sequence for Code Module

08912-074

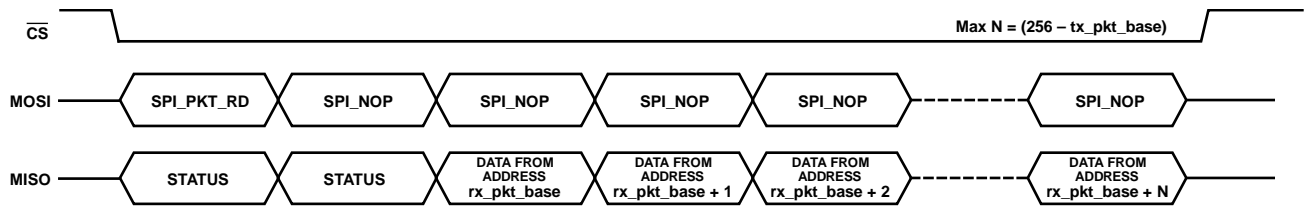

Figure 111. Packet RAM Read
(*rx_pkt_base* is the address base pointer value for RX, which is programmed in Register *rxbp*, Bit *rx_pkt_base*.)

08912-035

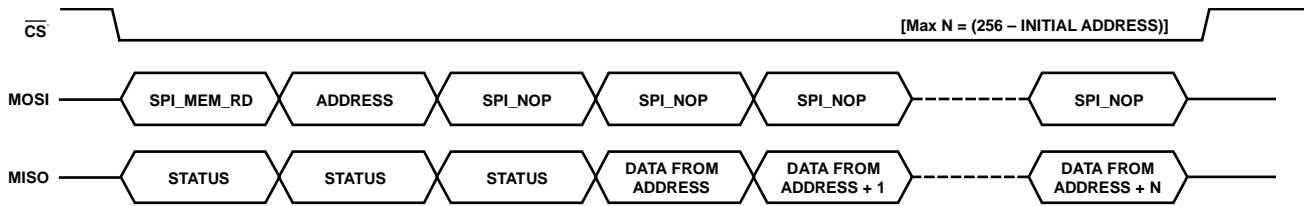

Figure 112. Memory (Register or Packet RAM) Block Read

08912-034

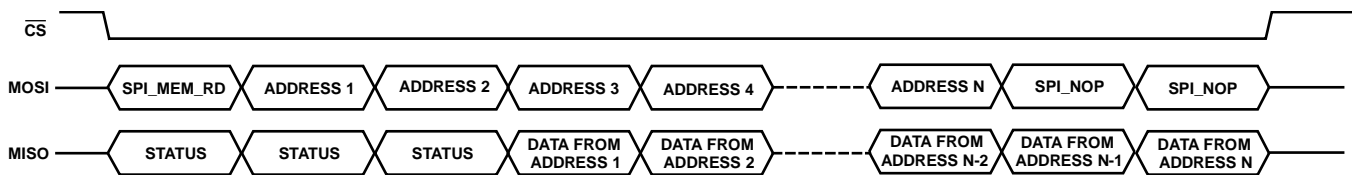

Figure 113. Memory (Register or Packet RAM) Random Address Read

08912-037

DOWNLOADABLE FIRMWARE MODULES

The program RAM of the ADF7242 can be used to store firmware modules for the on-chip processor that provide extra functionality. The executable code for these firmware modules

and details on their functionality are available from Analog Devices. See the Writing to the ADF7242 section for details on how to download these firmware modules to program RAM.

INTERRUPT CONTROLLER

CONFIGURATION

The ADF7242 is equipped with an interrupt controller that is capable of handling up to 16 independent interrupt events. The interrupt events can be triggered either by hardware circuits or the packet manager and are captured in Register `irq_src0` (0x3CB) and Register `irq_src1` (0x3CC).

The interrupt signals are available on two interrupt pins, `IRQ1_GP4` and `IRQ2_TRFS_GP2`. Each of the 16 interrupt sources can be individually enabled or disabled. The `irq1_en0` (0x3C7) and `irq1_en1` (0x3C8) registers control the functionality of the `IRQ1_GP4` interrupt pin. The `irq2_en0` (0x3C9) and `irq2_en1` (0x3CA) registers control the functionality of the `IRQ2_TRFS_GP2` interrupt pin. Refer to Table 48 and Table 49 for details on which bits in the relevant interrupt source and interrupt enable registers correspond to the different interrupts.

The `IRQ_STATUS` bit of the SPI status word, is asserted if an interrupt is present on either `IRQ1` or `IRQ2`. This is useful for host MCUs that may not have interrupt pins available.

The `irq_src1` and `irq_src0` registers can be read back to establish the source of an interrupt. An interrupt is cleared by writing 1 to the corresponding bit location in the appropriate interrupt source register (`irq_src1` or `irq_src0`). If 0 is written to a bit location in the interrupt source registers, its state remains unchanged. This scheme allows interrupts to be cleared individually and facilitates hierarchical interrupt processing.

The availability of two interrupt outputs permits a flexible allocation of interrupt source to two different MCU hardware

resources. For instance, an `rx_sfd` interrupt can be associated with a timer-capture unit of the MCU, while all other interrupts are handled by a normal interrupt handling routine. When operating in `SPORT` mode, Pin `IRQ2_TRFS_GP2` acts as a frame synchronization signal and is disconnected from the interrupt controller.

When in the sleep state, the `IRQ1_GP4` and `IRQ2_TRFS_GP2` pins have high impedance.

When not in the sleep state, Pin `IRQ1_GP4` and Pin `IRQ2_TRFS_GP2` are configured as push-pull outputs, using positive logic polarity.

Following a power-on reset or wake-up from sleep, Register `irq1_en0`, Field `powerup` and Register `irq2_en0`, Field `powerup` are set, while all other bits in the `irq1_en0`, `irq1_en1`, `irq2_en0`, and `irq2_en1` registers are reset. Therefore, a power-up interrupt signal is asserted on the `IRQ1_GP4` and `IRQ2_TRFS_GP2` pins after a power-on-reset event or wake-up from the sleep state. Provided the wake-up from sleep event is caused by the wake-up timer, the power-up interrupt signal can be used to power up the host MCU.

After the ADF7242 is powered up, the `rc_ready`, wake-up, and power-on reset interrupts are also asserted in the `irq_src0` register. However, these interrupts are not propagated to the `IRQ1_GP4` and `IRQ2_TRFS_GP2` pins because the corresponding mask bits are reset. The `irq_src0` and `irq_src1` registers should be cleared during the initialization phase.

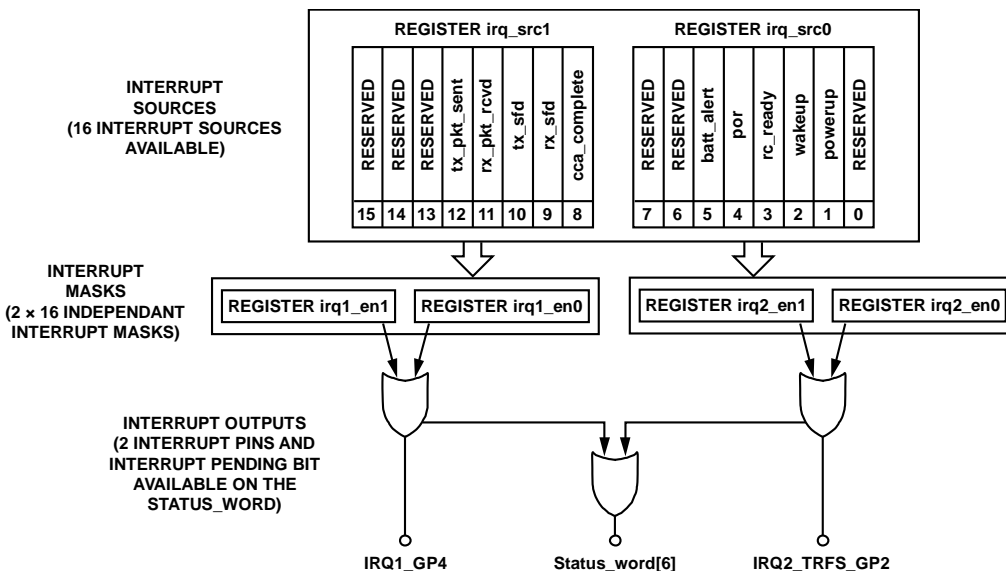

Figure 114. Interrupt Controller

06912-094

ADF7242

Table 48. Bit Locations in the Interrupt Source Register irq_src1, with Corresponding Interrupt Enables in irq1_en1, irq2_en1

Bit	Name	Notes
7	Reserved	Don't care; set mask to 0.
6	Reserved	Don't care; set mask to 0.
5	Reserved	Don't care; set mask to 0.
4	tx_pkt_sent	TX packet transmission complete.
3	rx_pkt_rcvd	Packet received in RX_BUFFER.
2	tx_sfd	SFD/SWD has been transmitted.
1	rx_sfd	SFD/SWD has been detected.
0	cca_complete	CCA_RESULT in status word is valid.

Table 49. Bit Locations in the Interrupt Source Register irq_src0, with Corresponding Interrupt Enables in irq1_en0, irq2_en0

Bit	Name	Notes
7	Reserved	Don't care; set mask to 0.
6	Reserved	Don't care; set mask to 0.
5	batt_alert	Battery voltage has dropped below programmed threshold value.
4	por	Power-on reset event.
3	rc_ready	Radio controller ready to accept new command.
2	wakeup	Timer has timed out.
1	powerup	Chip is ready for access.
0	Reserved	Don't care; set mask to 0.

DESCRIPTION OF INTERRUPT SOURCES

tx_pkt_sent

This interrupt is asserted when in IEEE 802.15.4-2006 or GFSK/FSK packet mode and the transmission of a packet in TX_BUFFER is complete.

rx_pkt_rcvd

This interrupt is asserted when in IEEE 802.15.4-2006 or GFSK/FSK packet mode and a packet with a valid FCS or CRC has been received and is available in RX_BUFFER.

tx_sfd

This interrupt is asserted if the SFD or SWD is transmitted when in IEEE 802.15.4-2006 or GFSK/FSK packet mode.

rx_sfd

This interrupt is asserted if a SFD or SWD is detected while in the RX state in either IEEE 802.15.4 or GFSK/FSK mode.

cca_complete

The interrupt is asserted at the end of a CCA measurement following a RC_RX or RC_CCA command. The interrupt indicates that the CCA_RESULT flag in the status word is valid.

batt_alert

The interrupt is asserted if the battery monitor signals a battery alarm. This occurs when the battery voltage drops below the programmed threshold value. The battery monitor must be enabled and configured. See the Battery Monitor section for further details.

rc_ready

The interrupt is asserted if the radio controller is ready to accept a new command. This condition is equivalent to the rising edge of the RC_READY flag in the status word.

wakeup

The interrupt is asserted if the WUC timer has decremented to zero. Prior to enabling this interrupt, the WUC timer unit must be configured with the tmr_cfg0, tmr_cfg1, tmr_rld0, and tmr_rld1 registers. A wake-up interrupt can be asserted while the ADF7242 is active or has woken up from the sleep state through a timeout event. See the Wake-Up Controller (WUC) section or further details.

powerup

The interrupt is asserted if the ADF7242 is ready for SPI access following a wake-up from the sleep state. This condition reflects a rising edge of the flag SPI_READY in the status word. If the ADF7242 has been woken up from the sleep state using the CS input, this interrupt is useful to detect that the ADF7242 has powered up without the need to poll the MISO output. Register irq1_mask, Field powerup and Register irq2_mask, Field powerup are automatically set on exit from the sleep state. Therefore, this interrupt is generated when a transition from sleep is triggered by CS being pulled low or by a timeout event.

APPLICATIONS CIRCUITS

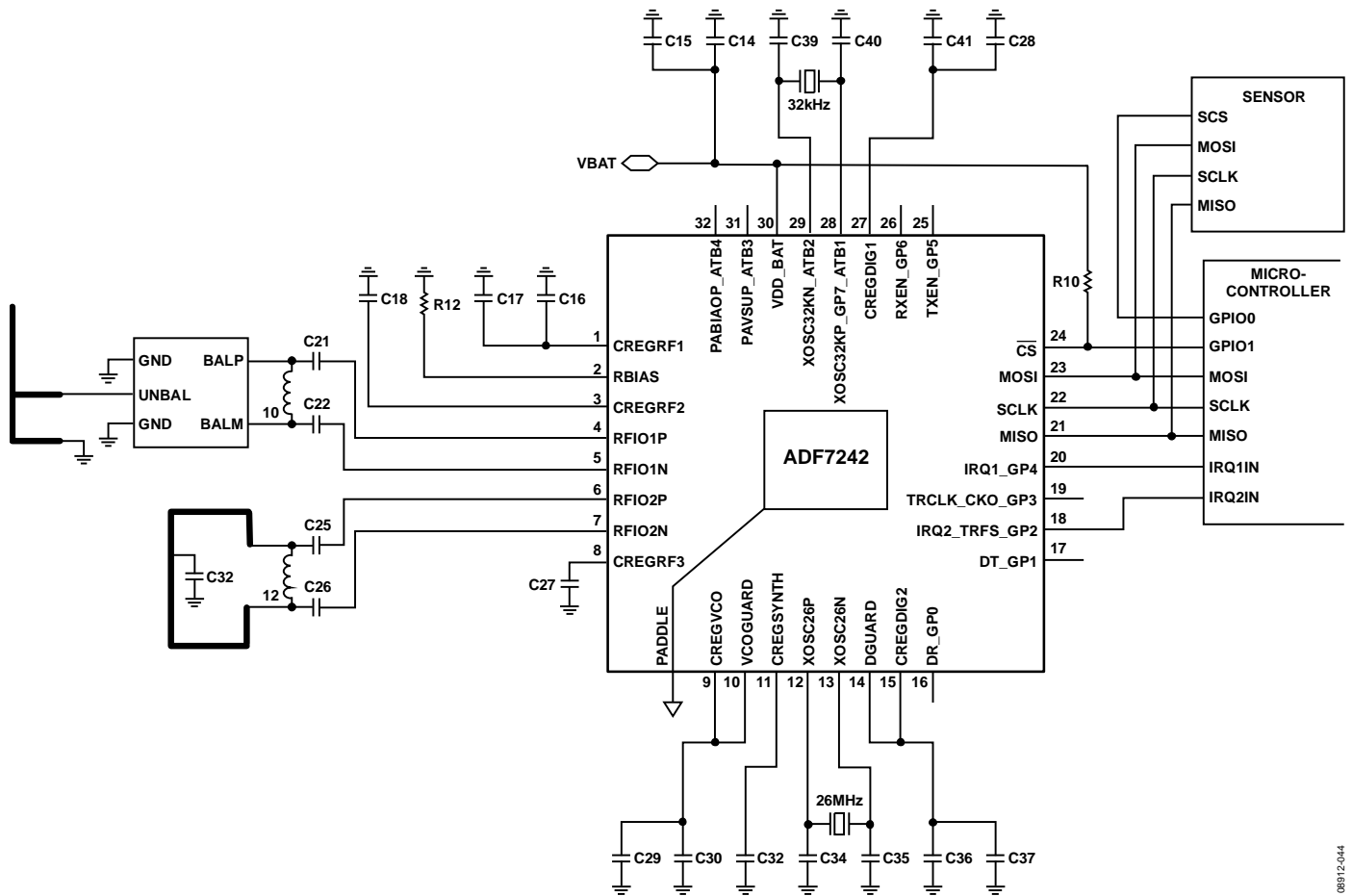

Figure 115. Typical ADF7242 Application Circuit Using Antenna Diversity

08912-044

ADF7242

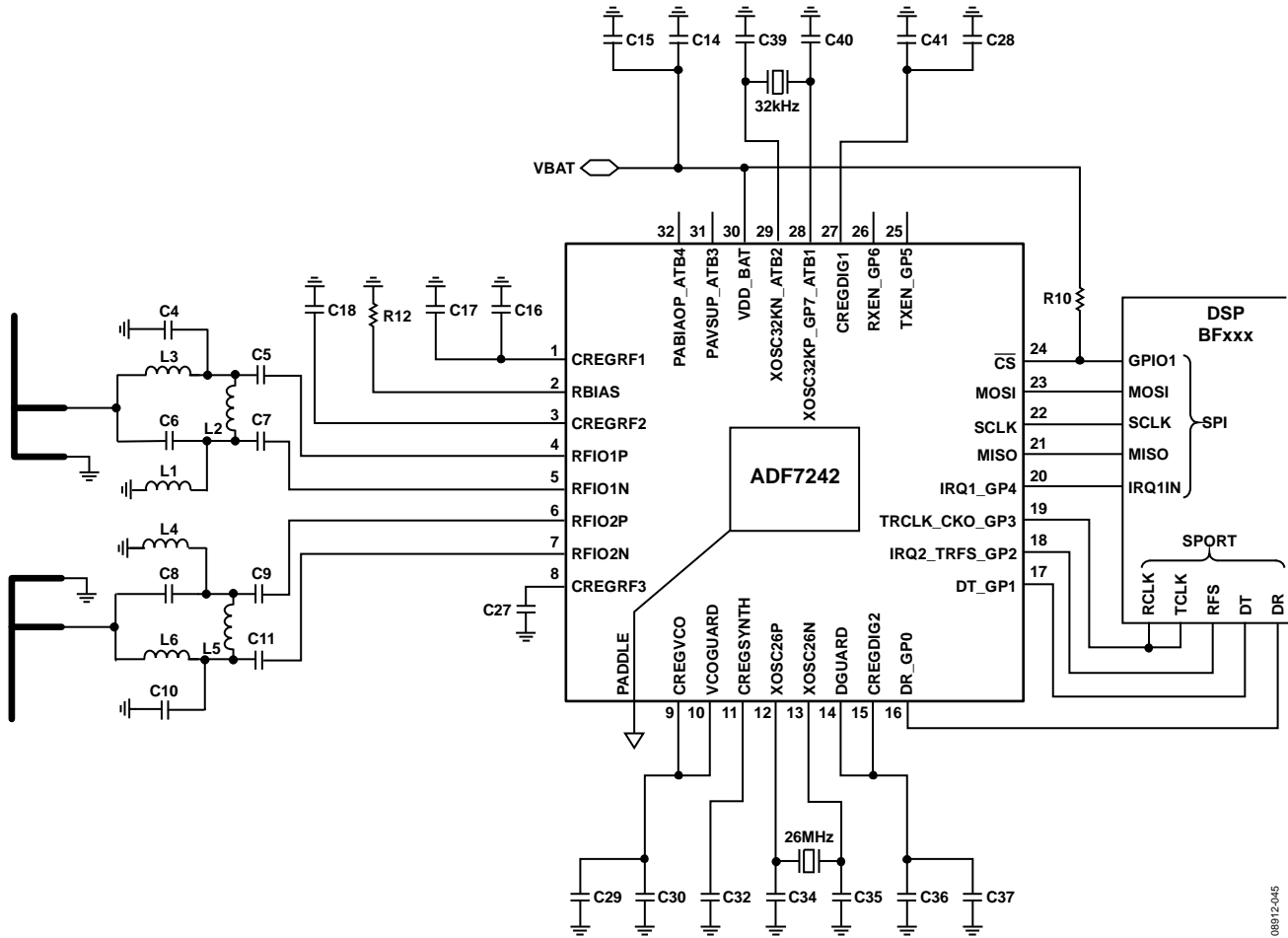

Figure 116. Typical ADF7242 Application Circuit with DSP Using Antenna Diversity

08512-045

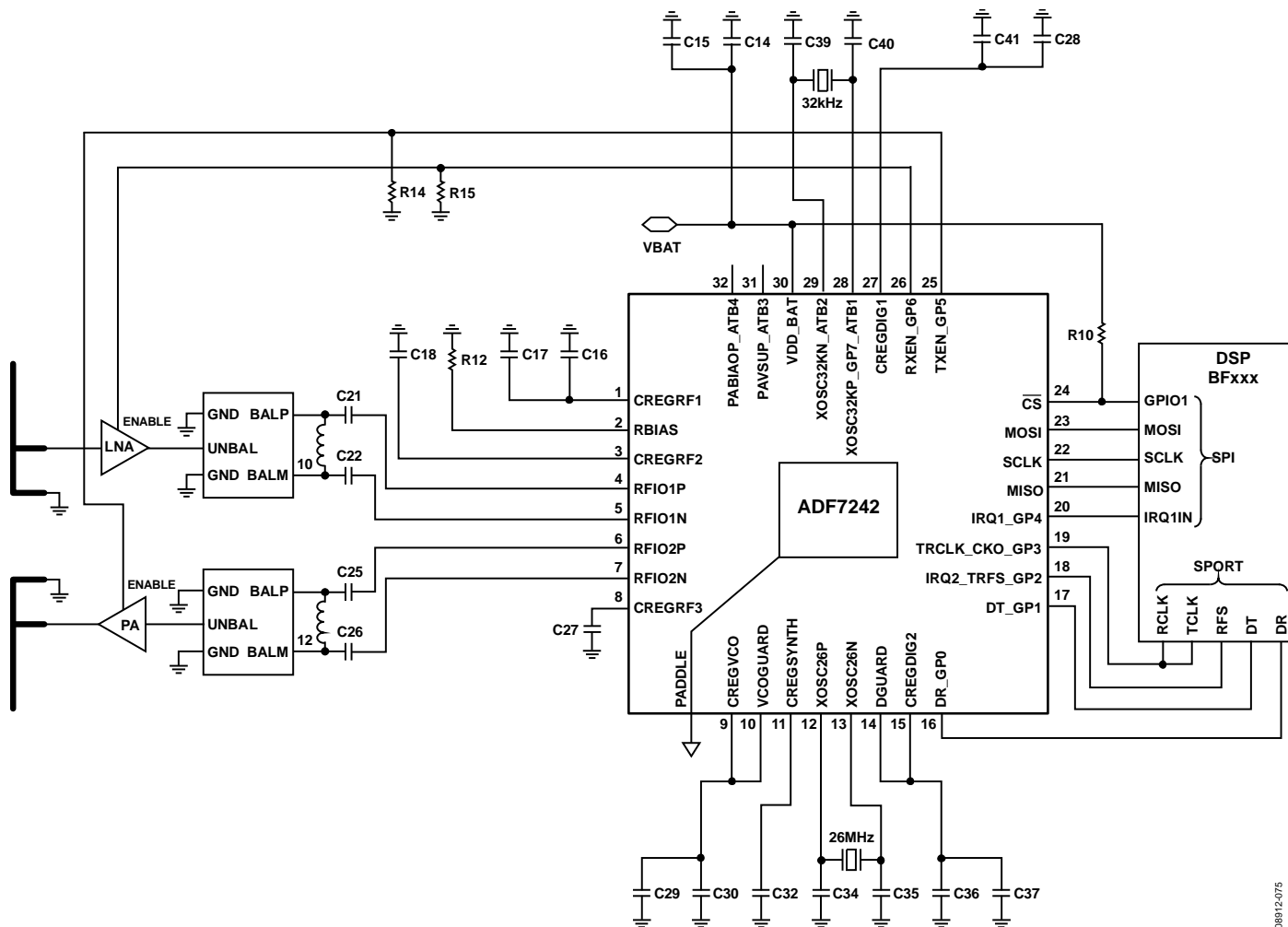

Figure 117. Typical ADF7242 Application Circuit with External LNA and External PA

08912-075

REGISTER MAP

It is recommended that configuration registers be programmed in the idle state. Note that all registers that include fields that are denoted as RC_CONTROLLED must be programmed in the idle state only.

Reset values are shown in decimal notation.

Table 50. Register Map Overview

Address	Register Name	Access Mode	Description
0x100	ext_ctrl	R/W	External LNA/PA and internal PA control configuration bits
0x102	fsk_preamble	R/W	GFSK/FSK preamble length configuration
0x105	cca1	R/W	RSSI threshold for CCA
0x106	cca2	R/W	CCA mode configuration
0x107	buffercfg	R/W	RX and TX Buffer configuration
0x108	pkt_cfg	R/W	Firmware download module enable/FCS/CRC control
0x109	delaycfg0	R/W	RC_RX command to SFD or SWD search delay
0x10A	delaycfg1	R/W	RC_TX command to TX state delay
0x10B	delaycfg2	R/W	MAC delay extension
0x10C	sync_word0	R/W	Sync Word Bits[7:0] of [23:0]
0x10D	sync_word1	R/W	Sync Word Bits[15:8] of [23:0]
0x10E	sync_word2	R/W	Sync Word Bits[23:16] of [23:0]
0x10F	sync_config	R/W	Sync word configuration
0x111	fsk_preamble_config	R/W	GFSK/FSK preamble configuration
0x13E	rc_cfg	R/W	Packet/SPORT mode configuration
0x300	ch_freq0	R/W	Channel frequency settings—low byte
0x301	ch_freq1	R/W	Channel frequency settings—middle byte
0x302	ch_freq2	R/W	Channel frequency settings—two MSBs
0x304	tx_fd	R/W	Transmit frequency deviation register
0x305	dm_cfg0	R/W	Receive discriminator bandwidth register
0x306	tx_m	R/W	Gaussian and preemphasis filter configuration
0x30C	rrb	R	RSSI readback register
0x30D	lrb	R	Signal quality indicator quality readback register
0x30E	dr0	R/W	Data rate [bps/100], Bits[15:8] of [15:0]
0x30F	dr1	R/W	Data rate [bps/100], Bits[7:0] of [15:0]
0x313	prampg	R/W	PRAM page
0x314	txpb	R/W	Transmit packet storage base address
0x315	rxpb	R/W	Receive packet storage base address
0x316	tmr_cfg0	R/W	Wake-up timer configuration register—high byte
0x317	tmr_cfg1	R/W	Wake-up timer configuration register—low byte
0x318	tmr_rld0	R/W	Wake-up timer value register—high byte
0x319	tmr_rld1	R/W	Wake-up timer value register—low byte
0x31A	tmr_ctrl	R/W	Wake-up timer timeout flag configuration register
0x31B	wuc_32khzosc_status	R	32 kHz oscillator/WUC status
0x31E	pd_aux	R/W	Battery monitor and external PA bias enable
0x32C	gp_cfg	R/W	GPIO configuration
0x32D	gp_out	R/W	GPIO configuration
0x335	synt	R/W	Synthesizer lock time
0x33D	rc_cal_cfg	R/W	RC calibration setting
0x353	vco_band_ovrw	R/W	Overwrite value for the VCO frequency band.
0x354	vco_idac_ovrw	R/W	Overwrite value for the VCO bias current DAC.
0x355	vco_ovwr_cfg	R/W	VCO calibration settings overwrite enable
0x36E	pa_bias	R/W	PA bias control
0x36F	vco_cal_cfg	R/W	VCO calibration parameters
0x371	xto26_trim_cal	R/W	26 MHz crystal oscillator configuration
0x380	vco_band_rb	R	Readback VCO band after calibration

ADF7242

Address	Register Name	Access Mode	Description
0x381	vco_idac_rb	R	Readback of the VCO bias current DAC after calibration
0x389	iirf_cfg	R/W	BB filter decimation rate
0x38B	dm_cfg1	R/W	Postdemodulator filter bandwidth
0x395	rxcal0	R/W	Receiver baseband filter calibration word, LSB
0x396	rxcal1	R/W	Receiver baseband filter calibration word, MSB
0x39B	rxfe_cfg	R/W	Receive baseband filter bandwidth and LNA selection
0x3A7	pa_rr	R/W	PA ramp rate
0x3A8	pa_cfg	R/W	PA output stage current control
0x3A9	extpa_cfg	R/W	External PA bias DAC configuration
0x3AA	extpa_msc	R/W	External PA interface circuit configuration
0x3AE	adc_rbk	R	ADC readback
0x3B2	agc_cfg1	R/W	AGC configuration parameters
0x3B4	agc_max	R/W	AGC configuration parameters
0x3B6	agc_cfg2	R/W	AGC configuration parameters
0x3B7	agc_cfg3	R/W	AGC configuration parameters
0x3B8	agc_cfg4	R/W	AGC configuration parameters
0x3B9	agc_cfg5	R/W	AGC configuration parameters
0x3BA	agc_cfg6	R/W	AGC configuration parameters
0x3BC	agc_cfg7	R/W	AGC configuration parameters
0x3BF	ocl_cfg0	R/W	OCL system parameters
0x3C4	ocl_cfg1	R/W	OCL system parameters
0x3C7	irq1_en0	R/W	Interrupt Mask Set Bits[7:0] of [15:0] for IRQ1
0x3C8	irq1_en1	R/W	Interrupt Mask Set Bits[15:8] of [15:0] for IRQ1
0x3C9	irq2_en0	R/W	Interrupt Mask Set Bits[7:0] of [15:0] for IRQ2
0x3CA	irq2_en1	R/W	Interrupt Mask Set Bits[15:8] of [15:0] for IRQ2
0x3CB	irq1_src0	R/W	Interrupt Source Bits[7:0] of [15:0] for IRQ
0x3CC	irq1_src1	R/W	Interrupt Source Bits[15:8] of [15:0] for IRQ
0x3D2	ocl_bw0	R/W	OCL system parameters
0x3D3	ocl_bw1	R/W	OCL system parameters
0x3D4	ocl_bw2	R/W	OCL system parameters
0x3D5	ocl_bw3	R/W	OCL system parameters
0x3D6	ocl_bw4	R/W	OCL system parameters
0x3D7	ocl_bws	R/W	OCL system parameters
0x3E0	ocl_cfg13	R/W	OCL system parameters
0x3E3	gp_drv	R/W	GPIO and SPI I/O pads drive strength configuration
0x3E6	bm_cfg	R/W	Battery monitor threshold voltage setting
0x3F0	tx_fsk_test	R/W	TX GFSK/FSK SPORT test mode configuration
0x3F3	preamble_num_validate	R/W	Preamble validation
0x3F4	sfd_15_4	R/W	Option to set nonstandard SFD
0x3F7	afc_cfg	R/W	AFC mode and polarity configuration
0x3F8	afc_ki_kp	R/W	AFC ki and kp
0x3F9	afc_range	R/W	AFC range
0x3FA	afc_read	R/W	AFC frequency error readback

Table 51. 0x100: ext_ctrl

Bit	Field Name	R/W	Reset Value	Description
[7]	pa_shutdown_mode	R/W	0	PA shutdown mode. 0: fast ramp-down. 1: user defined ramp-down.
[6:5]	Reserved	R/W	0	Reserved, set to default.
4	rxen_en	R/W	0	1: RXEN_GP6 is set high while in the RX state; otherwise, it is low. 0: RXEN_GP6 is under user control (refer to Register gp_out); refer to Register gp_cfg for restrictions
3	txen_en	R/W	0	1: TXEN_GP5 is set high while in the TX state; otherwise, it is low. 0: TXEN_GP5 is under user control (refer to Register gp_out); refer to Register gp_cfg for restrictions.
2	extpa_auto_en	R/W	0	1: RC enables external PA controller while in the TX state. 0: Register pd_aux, Bit extpa_bias_en (0x31E[4]) is under user control.
[1:0]	Reserved	R/W	0	Reserved, set to default.

Table 52. 0x102: fsk_preamble

Bit	Field Name	R/W	Reset Value	Description
[7:0]	Nbtx_preamble_byte	R/W	8	Set the number of preamble bytes that is appended at the beginning of a TX GFSK/FSK frame. Note that the packet manager automatically transmits another n bytes of preamble, with n set by MCR Register 0x3F3. Depending on the SWD used, there may also be additional preamble bits contained in Register 0x10C to Register 0x10E. Refer to the Transmitter in GFSK/FSK Mode section for details.

Table 53. 0x105: cca1

Bit	Field Name	R/W	Reset Value	Description
[7:0]	cca_thres	R/W	171	RSSI threshold for CCA. Signed twos complement notation (in dBm). When CCA is completed: Status Word CCA_RESULT = 1 if Register rrb, Bit rssi_readback (0x30C[7:0]) < cca_thres Status Word CCA_RESULT = 0 if Register rrb, Bit rssi_readback (0x30C[7:0]) ≥ cca_thres

Table 54. 0x106: cca2

Bit	Field Name	R/W	Reset Value	Description
[7:3]	Reserved	R/W	0	Reserved, set to default.
2	continuous_cca	R/W	0	0: continuous CCA off. 1: generate a CCA interrupt every 128 μs.
1	rx_auto_cca	R/W	0	0: automatic CCA off. 1: generate a CCA interrupt 128 μs after entering the RX state.
0	Reserved	R/W	0	Reserved, set to default.

ADF7242

Table 55. 0x107: buffercfg

Bit	Field Name	R/W	Reset Value	Description
7	trx_mac_delay	R/W	0	0: tx_mac_delay (0x10A[7:0]) and rx_mac_delay (0x109[7:0]) enabled. 1: tx_mac_delay (0x10A[7:0]) and rx_mac_delay (0x109[7:0]) disabled.
6	Reserved	R/W	0	Reserved, set to default
[5:4]	tx_buffer_mode	RW	0	In IEEE 802.15.4-2006 mode. 0: return to PHY_RDY after frame in TX_BUFFER is transmitted once. 1: cyclic transmission of frame in TX_BUFFER after TX MAC delay with PA ramp-up/down between packets. 2: reserved. 3: cyclic transmission of frame in TX_BUFFER after TX MAC delay with PA kept on.
3	auto_tx_to_rx_turnaround	R/W	0	0: as per tx_buffer_mode setting. 1: automatically goes to RX after TX data transmitted.
2	auto_rx_to_tx_turnaround	R/W	0	0: as per rx_buffer_mode setting. 1: automatically goes to TX after RX packet received.
[1:0]	rx_buffer_mode	R/W	0	In IEEE 802.15.4-2006 mode. 0: first frame following a RC_RX command is stored in RX_BUFFER; device returns to PHY_RDY state after reception of first frame. 1: continuous reception of frames enabled; a new frame overwrites previous frame. 2: new frames not written to buffer. 3: reserved.

Table 56. 0x108: pkt_cfg

Bit	Field Name	R/W	Reset Value	Description
[7:5]	Reserved	R/W	0	Reserved, set to default.
4	addon_en	R/W	0	0: firmware add-on module disabled. 1: firmware add-on module enabled; module must be loaded prior to setting this bit.
3	skip_synt_settle	R/W	0	0: the RF frequency synthesizer calibration and settling phase is performed. 1: skip the RF frequency synthesizer calibration and settling phase. This must only be used when the continuous packet transmission mode is enabled. Refer to the WUC Configuration and Operation section.
[2:1]	Reserved	R/W	2	Reserved, set to default.
0	auto_fcs_off	R/W	0	In IEEE 802.15.4-2006 and GFSK/FSK packet mode, the rx_pkt_rcvd interrupt is asserted. IEEE 802.15.4-2006: 0: receive operation—FCS automatically validated; FCS replaced with RSSI and SQI values in RX_BUFFER. Transmit operation—FCS automatically appended to transmitted packet; FCS field in TX_BUFFER is ignored. 1: receive operation—received FCS is stored in RX_BUFFER without validation. Transmit operation—FCS field in TX_BUFFER is transmitted. GFSK/FSK: 0: receive operation—CRC automatically validated. Transmit operation—CRC automatically appended to transmitted packet; CRC field in TX_BUFFER is ignored. 1: receive operation—received CRC is stored in RX_BUFFER without validation. Transmit operation—CRC field in TX_BUFFER is transmitted.

Table 57. 0x109: delaycfg0

Bit	Field Name	R/W	Reset Value	Description
[7:0]	rx_mac_delay	R/W	192	IEEE 802.15.4-2006 mode: programmable delay from issue of RC_RX command to SFD search and for start of RSSI measurement window. GFSK mode: programmable delay from issue of RC_RX command to SWD search. Programmable in steps of 1 μ s in both modes.

Table 58. 0x10A: delaycfg1

Bit	Field Name	R/W	Reset Value	Description
[7:0]	tx_mac_delay	R/W	192	IEEE 802.15.4-2006 mode and GFSK mode: programmable delay from issue of RC_TX command to entering TX state. Programmable in steps of 1 μ s in both modes.

Table 59. 0x10B: delaycfg2

Bit	Field Name	R/W	Reset Value	Description
[7:0]	mac_delay_ext	R/W	0	Programmable MAC delay extension. Programmable in steps of 4 μ s. Applies in both RX and TX states

Table 60. 0x10C: sync_word0

Bit	Field Name	R/W	Reset Value	Description
[7:0]	sync_word[7:0]	R/W	49	Sync Word Bits[7:0] of [23:0].

Table 61. 0x10D: sync_word1

Bit	Field Name	R/W	Reset Value	Description
[7:0]	sync_word[15:8]	R/W	122	Sync Word Bits[15:8] of [23:0].

Table 62. 0x10E: sync_word2

Bit	Field Name	R/W	Reset Value	Description
[7:0]	sync_word[23:16]	R/W	170	Sync word Bits[23:16] of [23:0].

Table 63. 0x10F: sync_config

Bit	Field Name	R/W	Reset Value	Description
7	Reserved	R/W	0	Reserved, set to default.
[6:5]	sync_tol	R/W	0	Number of bit mismatches allowed: 0 to 3. 4 to 7: reserved.
[4:0]	sync_len	R/W	24	Synchronization word length, which can be from 0 to 24. 0: sync word detection disabled. 25 to 31: reserved.

Table 64. 0x111: fsk_preamble_config

Bit	Field Name	R/W	Reset Value	Description														
7	reserved	R/W	0	Unused.														
6	skip_syncword_detect_sport	R/W	0	Bypass SFD detection (GFSK/FSK SPORT mode only). 0: perform sync word detection. 1: skip sync word detection.														
5	fsk_agc_lock_after_preamble	R/W	0	Lock AGC after preamble (GFSK/FSK packet/SPORT modes only). 0: disable AGC lock. 1: enable AGC lock.														
4	skip_preamble_detect_qual	R/W	0	Bypass preamble detection and qualification; only search for SWD . 0: enable preamble detection + qualification. 1: disable preamble detection + qualification.														
[3:0]	fsk_preamble_match_level	R/W	11	<table border="1"> <thead> <tr> <th>preamble_match</th> <th>Preamble qualification</th> </tr> </thead> <tbody> <tr> <td>0xC</td> <td>Enabled. 0 bit-pairs in error allowed in 12 bit-pairs.</td> </tr> <tr> <td>0xB</td> <td>Enabled. 1 bit-pair in error allowed in 12 bit-pairs.</td> </tr> <tr> <td>0xA</td> <td>Enabled. 2 bit-pairs in error allowed in 12 bit-pairs.</td> </tr> <tr> <td>0x9</td> <td>Enabled. 3 bit-pairs in error allowed in 12 bit-pairs.</td> </tr> <tr> <td>0x1</td> <td>Enabled. 11 bit-pairs in error allowed in 12 bit-pairs.</td> </tr> <tr> <td>0x0</td> <td>Preamble qualification disabled.</td> </tr> </tbody> </table>	preamble_match	Preamble qualification	0xC	Enabled. 0 bit-pairs in error allowed in 12 bit-pairs.	0xB	Enabled. 1 bit-pair in error allowed in 12 bit-pairs.	0xA	Enabled. 2 bit-pairs in error allowed in 12 bit-pairs.	0x9	Enabled. 3 bit-pairs in error allowed in 12 bit-pairs.	0x1	Enabled. 11 bit-pairs in error allowed in 12 bit-pairs.	0x0	Preamble qualification disabled.
preamble_match	Preamble qualification																	
0xC	Enabled. 0 bit-pairs in error allowed in 12 bit-pairs.																	
0xB	Enabled. 1 bit-pair in error allowed in 12 bit-pairs.																	
0xA	Enabled. 2 bit-pairs in error allowed in 12 bit-pairs.																	
0x9	Enabled. 3 bit-pairs in error allowed in 12 bit-pairs.																	
0x1	Enabled. 11 bit-pairs in error allowed in 12 bit-pairs.																	
0x0	Preamble qualification disabled.																	

ADF7242

Table 65. 0x13E: rc_cfg

Bit	Field Name	R/W	Reset Value	Description
[7:0]	rc_mode	R/W	0	Configure packet format: 0: IEEE 802.15.4-2006 packet mode. 1: reserved. 2: IEEE 802.15.4-2006 receive SPORT mode. 3: GFSK/FSK SPORT mode. 4: GFSK/FSK packet mode. 5 to 255: reserved.

Table 66. 0x300: ch_freq0

Bit	Field Name	R/W	Reset Value	Description
[7:0]	ch_freq[7:0]	R/W	128	Channel frequency [Hz]/10 kHz, Bits[7:0] of [23:0].

Table 67. 0x301: ch_freq1

Bit	Field Name	R/W	Reset Value	Description
[7:0]	ch_freq[15:8]	R/W	169	Channel frequency [Hz]/10 kHz, Bits[15:8] of [23:0].

Table 68. 0x302: ch_freq2

Bit	Field Name	R/W	Reset Value	Description
[7:0]	ch_freq[23:16]	R/W	3	Channel frequency [Hz]/10 kHz, Bits[23:16] of [23:0].

Table 69. 0x304: tx_fd

Bit	Field Name	R/W	Reset Value	Description
[7:6]	Reserved	R/W	0	Reserved, set to default.
[5:0]	tx_freq_dev	R/W	50	Transmit frequency deviation = tx_freq_dev × 10 kHz. Recommended settings: IEEE 802.15.4: use default setting of 50. GFSK/FSK: 62.5 kbps to 125 kbps: 6. 250 kbps: 13. 500 kbps: 25. 1000 kbps: 25. 2000 kbps: 50.

Table 70. 0x305: dm_cfg0

Bit	Field Name	R/W	Reset Value	Description
[7]	Reserved	R/W	0	Reserved, set to default.
[6:0]	discriminator_bw	R/W	6	Receive discriminator bandwidth = 3.25 MHz/(RX frequency deviation + freq_error_max). Recommended settings: IEEE 802.15.4: 6 (default). GFSK/FSK: 50 kbps, 62.5 kbps, 125 kbps: 55. 100 kbps: 107. 250 kbps: 25. 500 kbps, 1000 kbps: 13. 2000 kbps: 6.

Table 71. 0x306: tx_m

Bit	Field Name	R/W	Reset Value	Description
[7:2]	RC_CONTROLLED	R/W	0	Controlled by radio controller.
1	gauss_filt	R/W	0	1: GFSK, 0: FSK.
0	preemp_filt	R/W	1	1: enable, 0: disable preemphasis filter. Set for data rate > 250 kbps and IEEE 802.15.4-2006.

Table 72. 0x30C: rrb

Bit	Field Name	R/W	Reset Value	Description
[7:0]	rssi_readback	R	0	Receive input power in dBm; signed twos complement.

Table 73. 0x30D: lrb

Bit	Field Name	R/W	Reset Value	Description
[7:0]	sqi_readback	R	0	Signal quality indicator readback value.

Table 74. 0x30E: dr0

Bit	Field Name	R/W	Reset Value	Description
[7:0]	data_rate_high	R/W	78	Data rate: $256 \times \text{data_rate_high} \times 100 \text{ bps} + \text{dr1}$.

Table 75. 0x30F: dr1

Bit	Field Name	R/W	Reset Value	Description
[7:0]	data_rate_low	R/W	32	Data rate: $\text{data_rate_low} \times 100 \text{ bps} + \text{dr0}$.

Table 76. 0x313: prampg

Bit	Field Name	R/W	Reset Value	Description
[7:4]	Reserved	R/W	0	Reserved, set to default.
[3:0]	pram_page	R/W	0	Program PRAM page.

Table 77. 0x314: txpb

Bit	Field Name	R/W	Reset Value	Description
[7:0]	tx_pkt_base	R/W	128	Base address of TX_BUFFER in packet RAM.

Table 78. 0x315: rxpb

Bit	Field Name	R/W	Reset Value	Description
[7:0]	rx_pkt_base	R/W	0	Base address of RX_BUFFER in packet RAM.

ADF7242

Table 79. 0x316: tmr_cfg0

Bit	Field Name	R/W	Reset Value	Description
[7:3]	Reserved	R/W	0	Reserved, set to default.
[2:0]	timer_prescal	R/W	0	Divider factor for XTO32K or RCO. 0: ÷1. 1: ÷4. 2: ÷8. 3: ÷16. 4: ÷128. 5: ÷1024. 6: ÷8192. 7: ÷65,536. Note that this is a write-only register and should be written to prior to writing to Register tmr_cfg1. Settings become effective only after writing to Register tmr_cfg1.

Table 80. 0x317: tmr_cfg1

Bit	Field Name	R/W	Reset Value	Description
7	Reserved	R/W	0	Reserved, set to default.
[6:3]	sleep_config	R/W	0	1: SLEEP_BBRAM 4: SLEEP_XTO. 5: SLEEP_BBRAM_XTO. 11: SLEEP_BBRAM_RCO. 0, 3, 6 to 10, 12 to 15: reserved. Refer to note in Register tmr_cfg0.
[2:1]	Reserved	R/W	0	Reserved, set to default.
0	wake_on_timeout	R/W	0	1: enable, 0: disable wake-up on timeout event.

Table 81. 0x318: tmr_rld0

Bit	Field Name	R/W	Reset Value	Description
[7:0]	timer_reload[15:8]	R/W	0	Timer reload value, Bits[15:8] of [15:0]. Note that this is a write-only register and should be written to prior to writing to Register tmr_rld1. Settings become effective only after writing to Register tmr_rld1.

Table 82. 0x319: tmr_rld1

Bit	Field Name	R/W	Reset Value	Description
[7:0]	timer_reload[7:0]	R/W	0	Timer reload value, Bits[7:0] of [15:0]. Refer to note in Register tmr_rld0.

Table 83. 0x31A: tmr_ctrl

Bit	Field Name	R/W	Reset Value	Description
[7:2]	Reserved	R/W	0	Reserved, set to default.
1	wuc_rc_osc_cal	R/W	0	1: enable. 0: disable 32 kHz RC oscillator calibration.
0	wake_timer_flag_reset	R/W	0	Timer flag reset. 0: normal operation 1: reset fields wuc_tmr_prim_toflag and wuc_porflag (0x31B)

Table 84. 0x31B: wuc_32khzosc_status

Bit	Field Name	R/W	Reset Value	Description
[7:6]	Reserved	R	0	Reserved, set to default.
5	rc_osc_cal_ready	R	0	32 kHz RC oscillator calibration (only valid if wuc_rc_osc_cal = 1). Calibration takes 1 ms. 0: calibration in progress. 1: calibration finished.
4	xosc32_ready	R	0	32 kHz crystal oscillator (only valid if sleep_config (0x317[6:3])= 4 or 5). 0: oscillator not settled. 1: oscillator has settled.
3	Reserved	R	0	Reserved, set to default.
2	wuc_porflag	R	0	Chip cold start event registration. 0: not registered. 1: registered.
1	wuc_tmr_prim_toflag	R	0	WUC timeout event registration (the output of a latch triggered by a timeout event.) 0: not registered. 1: registered.
0	Reserved	R	0	Reserved, set to default.

Table 85. 0x31E: pd_aux

Bit	Field Name	R/W	Reset Value	Description
7	Reserved	R/W	0	Reserved, set to default.
6	RC_CONTROLLED	R/W	0	Controlled by radio controller.
5	battmon_en	R/W	0	1: enable. 0: disable battery monitor.
4	extpa_bias_en	R/W	0	1: enable. 0: disable external PA biasing circuit. Controlled by radio controller when Register ext_ctrl, Field extpa_auto_en = 1 (0x100[2]).
[3:0]	RC_CONTROLLED	R/W	0	Controlled by radio controller.

Table 86. 0x32C: gp_cfg

Bit	Field Name	R/W	Reset Value	Description
[7:0]	gpio_config	R/W	0	0: IRQ1, IRQ2 functionality. Register gp_out, Bit gpio_dout[6] controls RXEN output. Register gp_out, Bit gpio_dout[5] controls TXEN output. 1, 4: TRCLK and Data pins active in RX, without gating by frame detection. 2, 5: TRCLK and Data pins activity gated by preamble detection. 3, 6: TRCLK and Data pins activity gated by synchronization word detection. 6: IRQ1, DR, DT, TRFS, TRCLK functionality. Register gp_out, Bit gpio_dout[6] controls RXEN output. Register gp_out, Bit gpio_dout[5] controls TXEN output. 7: symbol clock output on TRCLK pin and symbol data output on GP6, GP5, GP1, and GP0. 103: IRQ1, DR, DT, IRQ2, TRCLK functionality. Register gp_out, Bit gpio_dout[6] controls RXEN output. Register gp_out, Bit gpio_dout[5] controls TXEN output. 8 to 102, 104 to 255: reserved.

ADF7242

Table 87. 0x32D: gp_out

Bit	Field Name	R/W	Reset Value	Description
[7:0]	gpio_dout	R/W	0	GPIO output value if Register gp_cfg, Field gpio_config = 4. gpio_dout[7:0] = GP7 to GP0. If Register ext_ctrl, Bit rxen_en = 1, then Register gp_out, Bit gpio_dout[6] is controlled by radio controller. If Register ext_ctrl, Bit txen_en = 1, then Register gp_out, Bit gpio_dout[5] is controlled by radio controller.

Table 88. 0x335: synt

Bit	Field Name	R/W	Reset Value	Description
[7:0]	lock_time	R/W	23	Synthesizer locking timeout period (46 μ s). 1 LSB = 2 μ s.

Table 89. 0x33D: rc_cal_cfg

Bit	Field Name	R/W	Reset Value	Description
[7:2]	Reserved	R/W	15	Reserved, set to default.
[1:0]	skip_rc_cal	R/W	0	0: do not skip RC calibration. This calibration is performed only when transitioning from idle to PHY_RDY. 3: skip RC calibration.

Table 90. 0x353: vco_band_ovrw

Bit	Field Name	R/W	Reset Value	Description
[7:0]	vco_band_ovrw_val	R/W	0	Overwrite value for the VCO frequency band. Enabled when vco_band_ovrw_en = 1 and Register vco_cal_cfg, Field skip_vco_cal = 15.

Table 91. 0x354: vco_idac_ovrw

Bit	Field Name	R/W	Reset Value	Description
[7:0]	vco_idac_ovrw_val	R/W	0	Overwrite value for the VCO bias current DAC. Enabled when Register vco_cal_cfg, Field skip_vco_cal = 15 and vco_idac_ovrw_en = 1.

Table 92. 0x355: vco_ovrw_cfg

Bit	Field Name	R/W	Reset Value	Description
[7:2]	Reserved	R/W	2	Reserved, set to default.
[1]	vco_idac_ovrw_en	R/W	0	VCO bias current DAC overwrite. Effective only if Register vco_cal_cfg, Field skip_vco_cal = 15. 0: disable. 1: enable.
[0]	vco_band_ovrw_en	R/W	0	VCO frequency band overwrite. Effective only if Register vco_cal_cfg, Field skip_vco_cal = 15. 0: disable. 1: enable.

Table 93. 0x36E: pa_bias

Bit	Field Name	R/W	Reset Value	Description
7	Reserved	R/W	0	Reserved, set to default.
[6:1]	pa_bias_ctrl	R/W	55	Set to 63 if maximum PA output power of 4.8 dBm is required.
0	Reserved	R/W	1	Reserved, set to default.

Table 94. 0x36F: vco_cal_cfg

Bit	Field Name	R/W	Reset Value	Description
[7:4]	Reserved	R/W	0	Reserved, set to default.
[3:0]	skip_vco_cal	R/W	9	9: do not skip VCO calibration. 15: skip VCO calibration

Table 95. 0x371: xto26_trim_cal

Bit	Field Name	R/W	Reset Value	Description
[7:6]	Reserved	R/W	0	Reserved, set to default.
[5:3]	xto26_trim	R/W	4	26 MHz crystal oscillator (XOSC26N) tuning capacitor control word. The load capacitance is adjusted according to the value of xto26_trim as follows: 0: -4×187.5 ff. 1: -3×187.5 ff. 2: -2×187.5 ff. 3: -1×187.5 ff. 4: 0×187.5 ff. 5: 1×187.5 ff. 6: 2×187.5 ff. 7: 3×187.5 ff.
[2:0]	Reserved	R/W	0	Reserved, set to default.

Table 96. 0x381: vco_band_rb

Bit	Field Name	R/W	Reset Value	Description
[7:2]	vco_band_val_rb	R	0	Readback for the VCO frequency band after calibration

Table 97. 0x381: vco_idac_rb

Bit	Field Name	R/W	Reset Value	Description
[7:2]	vco_idac_val_rb	R	0	Read-back of the VCO bias current DAC after calibration

Table 98. 0x389: iirf_cfg

Bit	Field Name	R/W	Reset Value	Description
[7:5]	Reserved	R/W	0	Reserved, set to default.
[4:2]	iir_stage2_bw	R/W	1	Receive baseband digital filter Stage 2 sampling rate $fs2 = fs1 / (2^{iir_stage2_bw})$. For IEEE 802.15.4-2006: set to default. For GFSK: 62.5 kbps to 250 kbps: 4. 500 kbps: 3. 1000 kbps: 2. 2000 kbps: 1.
[1:0]	iir_stage1_bw	R/W	1	Receive baseband digital filter Stage 1 sampling rate, $fs1 = 13 \text{ MHz} / (2^{iir_stage1_bw})$. For IEEE 802.15.4-2006: set to default. For GFSK: 62.5 kbps to 1000 kbps: 2. 2000 kbps: 1.

ADF7242

Table 99. 0x38B: dm_cfg1

Bit	Field Name	R/W	Reset Value	Description
[7:0]	postdemod_bw	R/W	200	Post demodulator filter BW= postdemod_bw × 15 kHz. For IEEE 802.15.4-2006: 133. For GFSK: 62.5 kbps: 8. 125 kbps: 17. 250 kbps: 32. 500 kbps: 61. 1000 kbps: 110. 2000 kbps: 170.

Table 100. 0x395: rxcal0

Bit	Field Name	R/W	Reset Value	Description
[7:0]	dcap_ovwrt_low	R/W	0	RXBB filter tuning overwrite word, LSB.

Table 101. 0x396: rxcal1

Bit	Field Name	R/W	Reset Value	Description
[7:2]	Reserved	R/W	2	Reserved, set to default.
1	dcap_ovwrt_en	R/W	0	RXBB filter tuning overwrite word enable.
0	dcap_ovwrt_high	R/W	0	RXBB filter tuning overwrite word, MSB.

Table 102. 0x39B: rxfe_cfg

Bit	Field Name	R/W	Reset Value	Description
[7:5]	Reserved	R/W	0	Reserved, set to default.
[4]	lna_sel	R/W	1	Receive: 0: use LNA1. 1: use LNA2.
[3:0]	rxbb_bw_ana	R/W	13	RXBB analog filter bandwidth: 15 = 1186 kHz 14 = 1086 kHz 13 = 1029 kHz 12 = 991 kHz 11 = 927 kHz 10 = 867 kHz 9 = 797 kHz 8 = 730 kHz 7 = 655 kHz 6 = 555 kHz For IEEE 802.15.4-2006 mode: set to default. For GFSK: 62.5 kbps to 1000 kbps: set to 6. 2000 kbps: set to 13.

Table 103. 0x3A7: pa_rr

Bit	Field Name	R/W	Reset Value	Description
[7:3]	Reserved	R/W	0	Reserved, set to default.
[2:0]	pa_ramp_rate	R/W	7	PA ramp rate: $2^{pa_rr.pa_ramp_rate} \times 2.4$ ns per PA power step.

Table 104. 0x3A8: pa_cfg

Bit	Field Name	R/W	Reset Value	Description
7	Reserved	R/W	0	Reserved, set to default.
[6:5]	Reserved	R/W	0	Set to default.
[4:0]	pa_bridge_dbias	R/W	13	Set to 21 if output power of 4.8 dBm is required from PA.

Table 105. 0x3A9: extpa_cfg

Bit	Field Name	R/W	Reset Value	Description
[7:5]	Reserved	R/W	0	Reserved, set to default.
[4:0]	extpa_bias	R/W	0	If Register extpa_msc, Field extpa_bias_mode = 1, 2, 3, or 4, PABIAOP_ATB4 pin DAC current = $80 \mu\text{A} - 2.58 \mu\text{A} \times \text{extpa_bias}$. If Register extpa_msc, Field extpa_bias_mode = 5 or 6, PAVSUP_ATB3 pin servo current set point = $22 \text{ mA} - 0.349 \text{ mA} \times \text{extpa_bias}$.

Table 106. 0x3AA: extpa_msc

Bit	Field Name	R/W	Reset Value	Description
[7:4]	pa_pwr	R/W	15	PA output power after ramping phase: 3: minimum power. 15: maximum power. Nominal power step size 2 dB per LSB.
3	extpa_bias_src	R/W	0	0: select RBIAS-referred reference current. 1: select band gap-referred reference current.
[2:0]	extpa_bias_mode	R/W	1	External PA interface configuration: 0: PAVSUP_ATB3 = on; PABIAOP_ATB4 = floating. 1: PAVSUP_ATB3 = on; PABIAOP_ATB4 = current source. 2: PAVSUP_ATB3 = on; PABIAOP_ATB4 = current sink. 3: PAVSUP_ATB3 = off; PABIAOP_ATB4 = current source. 4: PAVSUP_ATB3 = off; PABIAOP_ATB4 = current sink. 5: PAVSUP_ATB3 = on; PABIAOP_ATB4 = positive servo output. 6: PAVSUP_ATB3 = on; PABIAOP_ATB4 = negative servo output. 7: reserved.

Table 107. 0x3AE: adc_rbk

Bit	Field Name	R/W	Reset Value	Description
[7:6]	Reserved	R	0	Ignore.
[5:0]	adc_out	R	0	ADC output code.

Table 108. 0x3B2: agc_cfg1

Bit	Field Name	R/W	Reset Value	Description
7	Reserved	R/W	0	Reserved, set to default.
[6:5]	agc_lna_hyst	R/W	1	Hysteresis in terms of PGA attenuation steps for LNA gain transitions.
[4:1]	agc_lna_thres	R/W	8	Sets number of PGA attenuation steps prior to first LNA attenuation step.
0	agc_lock	R/W	0	0: enable, 1: freeze AGC.

Table 109. 0x3B4: agc_max

Bit	Field Name	R/W	Reset Value	Description
[7:6]	Reserved	R/W	2	Reserved, set to default.
[5:3]	agc_sat_thres_offs	R/W	2	ADC saturation detection threshold offset from full scale; the AGC enters slewing mode when this threshold is exceeded.
[2:0]	Reserved	R/W	0	Reserved, set to default.

ADF7242

Table 110. 0x3B6: agc_cfg2

Bit	Field Name	R/W	Reset Value	Description
7	Reserved	R/W	0	Reserved, set to default.
[6:0]	agc_thres_hi	R/W	46	AGC upper RSSI trigger threshold. For IEEE 802.15.4-2006: set to default. For GFSK mode: set to 55.

Table 111. 0x3B7: agc_cfg3

Bit	Field Name	R/W	Reset Value	Description
7	Reserved	R/W	0	Reserved, set to default.
[6:0]	agc_target	R/W	35	AGC RSSI active state target value. For IEEE 802.15.4-2006: set to default. For GFSK mode: set to 42.

Table 112. 0x3B8: agc_cfg4

Bit	Field Name	R/W	Reset Value	Description
7	Reserved	R/W	0	Reserved, set to default.
[6:0]	agc_thres_lo	R/W	24	AGC lower RSSI trigger threshold. For IEEE 802.15.4-2006: set to default. For GFSK mode: set to 29.

Table 113. 0x3B9: agc_cfg5

Bit	Field Name	R/W	Reset Value	Description
[7:5]	Reserved	R/W	0	Set to 0.
[4:2]	rss_i_offs	R/W	4	RSSI offset adjust, rss_i_offs is added to Register rrb, Field rss_i_readback.
[1:0]	rss_i_avg_time	R/W	3	RSSI averaging time; default per IEEE 802.15.4-2006; refer to the Baseband Filter section for further details.

Table 114. 0x3BA: agc_cfg6

Bit	Field Name	R/W	Reset Value	Description
[7:6]	Reserved	R/W	0	Reserved, set to default.
[5:3]	agc_filt2_tavg2	R/W	5	AGC postfilter averaging time. For IEEE 802.15.4-2006: per default. For GFSK: set to 4.
[2:0]	agc_filt2_tavg1	R/W	5	AGC postfilter averaging time for LNA transition. For IEEE 802.15.4-2006: per default. For GFSK/FSK: set to 4.

Table 115. 0x3BC: agc_cfg7

Bit	Field Name	R/W	Reset Value	Description
7	Reserved	R/W	0	Reserved, set to default.
[6:3]	agc_ndelay_steady	R/W	15	AGC agc_steady delay counter.
[2:0]	agc_egain_exp	R/W	1	AGC integrator gain.

Table 116. 0x3BF: ocl_cfg0

Bit	Field Name	R/W	Reset Value	Description
[7:2]	Reserved	R/W	0	Reserved, set to default.
1	ocl_en_gclna_ocl_hibw_state	R/W	1	1: enable 0: disable OCL wide bandwidth mode after LNA gain changes.
			0	IEEE 802.15.4 mode. GFSK/FSK mode.
0	Reserved	R/W	0	Reserved, set to default.

Table 117. 0x3C4: ocl_cfg1

Bit	Field Name	R/W	Reset Value	Description
[7:0]	ocl_fsk_lock_timeout	R/W	5	For IEEE 802.15.4-2006: per default. For GFSK/FSK: set to 7.

Table 118. 0x3C7: irq1_en0

Bit	Field Name	R/W	Reset Value	Description
7	Reserved	R/W	0	Set to 0.
6	Reserved	R/W	0	Set to 0.
5	batt_alert	R/W	0	Battery monitor interrupt.
4	por	R/W	0	Power-on reset event.
3	rc_ready	R/W	0	Radio controller ready to accept new command.
2	wakeup	R/W	0	Timer has timed out.
1	powerup	R/W	1	Chip is ready for access.
0	Reserved	R/W	0	Set to 0.

Table 119. 0x3C8: irq1_en1

Bit	Field Name	R/W	Reset Value	Description
7	Reserved	R/W	0	Set to 0.
6	Reserved	R/W	0	Set to 0.
5	Reserved	R/W	0	Set to 0.
4	tx_pkt_sent	R/W	0	Packet transmission complete.
3	rx_pkt_rcvd	R/W	0	Packet received in RX_BUFFER.
2	tx_sfd	R/W	0	SFD/SWD was transmitted.
1	rx_sfd	R/W	0	SFD/SWD was detected.
0	cca_complete	R/W	0	CCA_RESULT in status word is valid.

Table 120. 0x3C9: irq2_en0

Bit	Field Name	R/W	Reset Value	Description
7	Reserved	R/W	0	Set to 0.
6	Reserved	R/W	0	Set to 0.
5	batt_alert	R/W	0	Battery monitor interrupt.
4	por	R/W	0	Power-on reset event.
3	rc_ready	R/W	0	Radio controller ready to accept new command.
2	wakeup	R/W	0	Timer has timed out.
1	powerup	R/W	1	Chip is ready for access.
0	Reserved	R/W	0	Set to 0.

ADF7242

Table 121. 0x3CA: irq2_en1

Bit	Field Name	R/W	Reset Value	Description
7	Reserved	R/W	0	Set to 0.
6	Reserved	R/W	0	Set to 0.
5	Reserved	R/W	0	Set to 0.
4	tx_pkt_sent	R/W	0	Packet transmission complete.
3	rx_pkt_rcvd	R/W	0	Packet received in RX_BUFFER.
2	tx_sfd	R/W	0	SFD/SWD was transmitted.
1	rx_sfd	R/W	0	SFD/SWD was detected.
0	cca_complete	R/W	0	CCA_RESULT in status word is valid.

Table 122. 0x3CB: irq_src0

Bit	Field Name	R/W	Reset Value	Description
7	Reserved	R/W	0	Set to 0.
6	Reserved	R/W	0	Set to 0.
5	batt_alert	R/W	0	Battery monitor interrupt.
4	por	R/W	0	Power-on reset event.
3	rc_ready	R/W	0	Radio controller ready to accept new command.
2	wakeup	R/W	0	Timer has timed out.
1	powerup	R/W	0	Chip is ready for access.
0	Reserved	R/W	0	Set to 0.

Table 123. 0x3CC: irq_src1

Bit	Field Name	R/W	Reset Value	Description
7	Reserved	R/W	0	Set to 0.
6	Reserved	R/W	0	Set to 0.
5	Reserved	R/W	0	Set to 0.
4	tx_pkt_sent	R/W	0	Packet transmission complete.
3	rx_pkt_rcvd	R/W	0	Packet received in RX_BUFFER.
2	tx_sfd	R/W	0	SFD/SWD was transmitted.
1	rx_sfd	R/W	0	SFD/SWD was detected.
0	cca_complete	R/W	0	CCA_RESULT in status word is valid.

Table 124. 0x3D2: ocl_bw0

Bit	Field Name	R/W	Reset Value	Description
[7:5]	Reserved	R/W	0	Reserved, set to default.
[4:0]	ocl_bw0	R/W	27	For IEEE 802.15.4-2006: set to default. For GFSK/FSK: set to 26.

Table 125. 0x3D3: ocl_bw1

Bit	Field Name	R/W	Reset Value	Description
[7:5]	Reserved	R/W	0	Reserved, set to default.
[4:0]	ocl_bw1	R/W	26	For IEEE 802.15.4-2006: set to default. For GFSK/FSK: set to 25.

Table 126. 0x3D4: ocl_bw2

Bit	Field Name	R/W	Reset Value	Description
[7:5]	Reserved	R/W	0	Reserved, set to default.
[4:0]	ocl_bw2	R/W	2	For IEEE 802.15.4-2006: set to default. For GFSK/FSK: set to 30.

Table 127. 0x3D5: ocl_bw3

Bit	Field Name	R/W	Reset Value	Description
[7:5]	Reserved	R/W	0	Reserved, set to default.
[4:0]	ocl_bw3	R/W	3	For IEEE 802.15.4-2006: set to default. For GFSK/FSK: set to 30.

Table 128. 0x3D6: ocl_bw4

Bit	Field Name	R/W	Reset Value	Description
[7:5]	Reserved	R/W	0	Reserved, set to default.
[4:0]	ocl_bw4	R/W	2	For IEEE 802.15.4-2006: set to default. For GFSK/FSK: set to 30.

Table 129. 0x3D7: ocl_bws

Bit	Field Name	R/W	Reset Value	Description
[7:5]	Reserved	R/W	0	Reserved, set to default.
[4:0]	ocl_bw	R/W	0	For IEEE 802.15.4-2006: set to default. For GFSK/FSK: set to 0.

Table 130. 0x3E0: ocl_cfg13

Bit	Field Name	R/W	Reset Value	Description
[7:2]	Reserved	R/W	60	Reserved, set to default.
1	ocl_sosi_en	R/W	1	For IEEE 802.15.4-2006: set to default. For GFSK/FSK: set to 0.
0	Reserved	R/W	0	Reserved, set to default.

Table 131. 0x3E3: gp_drv

Bit	Field Name	R/W	Reset Value	Description
[7:4]	Reserved	R/W	0	Reserved, set to default.
[3:2]	gpio_slew	R/W	0	GPIO and SPI slew rate. 0: very slow. 1: slow. 2: very fast. 3: fast.
[1:0]	gpio_drive	R/W	0	GPIO and SPI drive strength. 0: 4 mA. 1: 8 mA. 2: >8 mA. 3: reserved.

Table 132. 0x3E6: bm_cfg

Bit	Field Name	R/W	Reset Value	Description
7:5]	Reserved	R/W	0	Reserved, set to default.
[4:0]	battmon_voltage	R/W	0	Battery monitor trip voltage: 1.7 V + 62 mV × battmon_voltage; the batt_alert interrupt is asserted when VDD_BAT drops below the trip voltage.

Table 133. 0x3F0: tx_fsk_test

Bit	Field Name	R/W	Reset Value	Description
[7:4]	Reserved	R/W	2	Reserved, set to default.
3	zero_only	R/W	0	Transmit 0 only ($f_{CH} - f_{DEV}$) in GFSK/FSK SPORT mode.
2	one_only	R/W	0	Transmit 1 only ($f_{CH} + f_{DEV}$) in GFSK/FSK SPORT mode.
1	carrier_only	R/W	0	Transmits unmodulated tone at the programmed frequency f_{CH} .
0	Reserved	R/W	0	Reserved, set to default.

ADF7242

Table 134. 0x3F3: preamble_num_validate

Bit	Field Name	R/W	Reset Value	Description
[7]	Reserved	R/W	0	Reserved, set to default.
[6:0]	num_preamble_bytes	R/W	5	Number of preamble bytes required for preamble validation.

Table 135. 0x3F4: sfd_15_4

Bit	Field Name	R/W	Reset Value	Description
[7:4]	sfd_symbol_2	R/W	10	Symbol 2 of SFD note: IEEE 802.15.4-2006 requires SFD1 = 10.
[3:0]	sfd_symbol_1	R/W	7	Symbol 1 of SFD note: IEEE 802.15.4-2006 requires SFD1 = 7.

Table 136. 0x3F7: afc_cfg

Bit	Field Name	R/W	Reset Value	Description
[7:3]	Reserved	R/W	0	Reserved, set to default.
[2]	afc_polarity	R/W	0	Set AFC polarity. Set to 1.
[1:0]	afc_mode	R/W	0	00: lock AFC. 01: reserved. 10: AFC is free running. 11: lock AFC on preamble detection.

Table 137. 0x3F8: afc_ki_kp

Bit	Field Name	R/W	Reset Value	Description
[7:4]	afc_kp	R/W	0	Sets the AFC PI controller proportional gain. For IEEE 802.15.4-2006: not used. For GFSK: set to 9.
[3:0]	afc_ki	R/W	0	Sets the AFC PI controller integral gain. For IEEE 802.15.4-2006: not used. For GFSK: set to 9.

Table 138. 0x3F9: afc_range

Bit	Field Name	R/W	Reset Value	Description
[7:0]	max_afc_range	R/W	0	Limits the AFC pull-in range. Should be set to half the receive baseband filter bandwidth. AFC pull-in range is \pm max_afc_range in kHz.

Table 139. 0x3FA: afc_read

Bit	Field Name	R/W	Reset Value	Description
[7:0]	afc_freq_error	R/W	0	Frequency error readback. Frequency error: 1 kHz/LSB.

OUTLINE DIMENSIONS

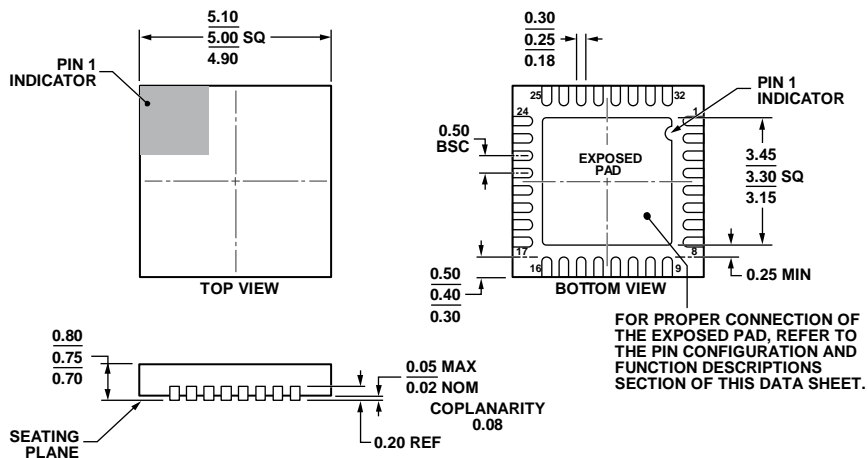

COMPLIANT TO JEDEC STANDARDS MO-220-WHHD.

Figure 119. 32-Lead Lead Frame Chip Scale Package [LFCSP_WQ]
 5 mm × 5 mm Body, Very Thin Quad
 (CP-32-13)
 Dimensions shown in millimeters

033009-A

ORDERING GUIDE

Model ¹	Temperature Range	Package Description	Package Option
ADF7242BCPZ	-40°C to +85°C	32-Lead Lead Frame Chip Scale Package [LFCSP_WQ]	CP-32-13
ADF7242BCPZ-RL	-40°C to +85°C	32-Lead Lead Frame Chip Scale Package [LFCSP_WQ]	CP-32-13
EVAL-ADF7242DB1Z		Evaluation Platform Daughterboard	
EVAL-ADF7XXMB3Z		Evaluation Platform Motherboard	

¹ Z = RoHS Compliant Part.

ADF7242

NOTES

NOTES

ADF7242

NOTES

X-ON Electronics

Largest Supplier of Electrical and Electronic Components

Click to view similar products for [RF Transceiver](#) category:

Click to view products by [Analog Devices](#) manufacturer:

Other Similar products are found below :

[ADRV9026BBCZ](#) [ADRV9026-MB/PCBZ](#) [ADL6316ACCZ](#) [ADL6316ACCZ-R7](#) [ADL6317ACCZ](#) [SYN480R](#) [VI4455](#) [CC1260RGZT](#)
[NRF51822-CEAA-R \(E0\)](#) [AT86RF232-ZX](#) [ADF7021-NBCPZ-RL](#) [ADRV9008BBCZ-2](#) [ADF7030-1BSTZN-RL](#) [AD9874ABSTRL](#)
[ADF7020-1BCPZ-RL7](#) [ADF7020BCPZ](#) [ADF7020BCPZ-RL](#) [ADF7021BCPZ](#) [ADF7021BCPZ-RL](#) [ADF7021BCPZ-RL7](#) [ADF7021-NBCPZ](#)
[ADF7021-VBCPZ](#) [ADF7023-JBCPZ](#) [ADF7025BCPZ](#) [ADF7241BCPZ](#) [ADRV9029BBCZ](#) [AT86RF231-ZU](#) [AT86RF232-ZXR](#) [AT86RF233-](#)
[ZF](#) [AT86RF233-ZU](#) [ATA8520-GHQW](#) [BRAVO-T868](#) [SX1236IMLTRT](#) [HT9170D](#) [BGT 24MTR11 E6327](#) [BGT24MTR11E6327XUMA1](#)
[BGT24MTR12E6327XUMA1](#) [MAX2510EEI+](#) [MAX2511EEI+](#) [MAX2510EEI+T](#) [MAX2832ETM+](#) [MAX7030LATJ+](#) [SX1212IWLTRT](#)
[MAX9947ETE+](#) [AT86RF212B-ZU](#) [AT86RF231-ZUR](#) [ATA5429-PLSW](#) [NRF24LE1-O17Q32-R](#) [AT86RF233-ZUR](#) [MRF24J40-I/ML](#)