

FEATURES

4.7 Ω maximum on resistance @ 25°C
0.5 Ω on resistance flatness
Up to 190 mA continuous current
Fully specified at ± 15 V/ $+12$ V/ ± 5 V
3 V logic-compatible inputs
Rail-to-rail operation
Break-before-make switching action
16-lead TSSOP

ENHANCED PRODUCT FEATURES

Supports defense and aerospace applications
(AQEC standard)
Military temperature range: -55°C to $+125^\circ\text{C}$
Controlled manufacturing baseline
One assembly and test site
One fabrication site
Enhanced product change notification
Qualification data available on request

GENERAL DESCRIPTION

The [ADG1408-EP/ADG1409-EP](#) are monolithic *i*CMOS® analog multiplexers comprising eight single channels and four differential channels, respectively. The [ADG1408-EP](#) switches one of eight inputs to a common output, as determined by the 3-bit binary address lines, A0, A1, and A2. The [ADG1409-EP](#) switches one of four differential inputs to a common differential output, as determined by the 2-bit binary address lines, A0 and A1. An EN input on both devices is used to enable or disable the device. When disabled, all channels are switched off.

The *i*CMOS (industrial CMOS) modular manufacturing process combines high voltage CMOS (complementary metal-oxide semiconductor) and bipolar technologies. It enables the development of a wide range of high performance analog ICs capable of 33 V operation in a footprint that no other generation of high voltage parts has been able to achieve. Unlike analog ICs using conventional CMOS processes, *i*CMOS components can tolerate high supply voltages while providing increased performance, dramatically lower power consumption, and reduced package size.

FUNCTIONAL BLOCK DIAGRAM

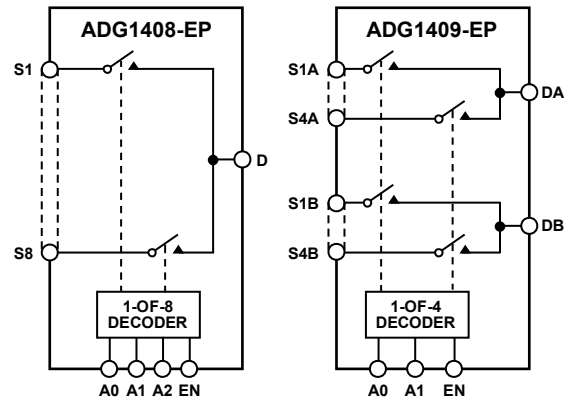

Figure 1.

09248-001

The ultralow on resistance and on resistance flatness of these switches make them ideal solutions for data acquisition and gain switching applications where low distortion is critical. *i*CMOS construction ensures ultralow power dissipation, making the parts ideally suited for portable and battery-powered instruments.

Full details about this enhanced product are available in the [ADG1408/ADG1409](#) data sheet, which should be consulted in conjunction with this data sheet.

PRODUCT HIGHLIGHTS

1. 4 Ω on resistance
2. 0.5 Ω on resistance flatness
3. 3 V logic-compatible digital input, $V_{INH} = 2.0$ V, $V_{INL} = 0.8$ V
4. 16-lead TSSOP package

TABLE OF CONTENTS

Features	1	5 V Dual Supply.....	7
Enhanced Product Features	1	Continuous Current per Channel, S or D.....	8
Functional Block Diagram	1	Absolute Maximum Ratings	9
General Description	1	ESD Caution.....	9
Product Highlights	1	Pin Configurations and Function Descriptions	10
Revision History	2	Typical Performance Characteristics	12
Specifications.....	3	Test Circuits.....	14
15 V Dual Supply.....	3	Outline Dimensions	16
12 V Single Supply.....	5	Ordering Guide	16

REVISION HISTORY

11/2017—Rev. A to Rev. B

Changes to Ordering Guide	16
---------------------------------	----

8/2017—Rev. 0 to Rev. A

Changes to Table 6.....	10
Changes to Table 7.....	11

3/2011—Revision 0: Initial Version

SPECIFICATIONS

15 V DUAL SUPPLY

$V_{DD} = +15\text{ V} \pm 10\%$, $V_{SS} = -15\text{ V} \pm 10\%$, $GND = 0\text{ V}$, unless otherwise noted.

Table 1.

Parameter	+25°C	-55°C to +125°C	Unit	Test Conditions/Comments
ANALOG SWITCH				
Analog Signal Range		V_{SS} to V_{DD}	V	
On Resistance (R_{ON})	4		Ω typ	$V_S = \pm 10\text{ V}$, $I_S = -10\text{ mA}$; see Figure 12
	4.7	6.7	Ω max	$V_{DD} = +13.5\text{ V}$, $V_{SS} = -13.5\text{ V}$
On Resistance Match Between Channels (ΔR_{ON})	0.2		Ω typ	$V_S = \pm 10\text{ V}$, $I_S = -10\text{ mA}$
	0.78	1.1	Ω max	
On Resistance Flatness ($R_{FLAT(ON)}$)	0.5		Ω typ	$V_S = \pm 10\text{ V}$, $I_S = -10\text{ mA}$
	0.72	0.92	Ω max	
LEAKAGE CURRENTS				
Source Off Leakage, I_S (Off)	± 0.04		nA typ	$V_{DD} = +16.5\text{ V}$, $V_{SS} = -16.5\text{ V}$
	± 0.2	± 5	nA max	$V_S = \pm 10\text{ V}$, $V_D = \mp 10\text{ V}$; see Figure 13
Drain Off Leakage, I_D (Off)	± 0.04		nA typ	$V_S = \pm 10\text{ V}$, $V_D = \mp 10\text{ V}$; see Figure 13
	± 0.45	± 30	nA max	
Channel On Leakage, I_D , I_S (On)	± 0.1		nA typ	$V_S = V_D = \pm 10\text{ V}$; see Figure 14
	± 1.5	± 30	nA max	
DIGITAL INPUTS				
Input High Voltage, V_{INH}		2.0	V min	
Input Low Voltage, V_{INL}		0.8	V max	
Input Current	± 0.005		μA typ	$V_{IN} = V_{GND}$ or V_{DD}
		± 0.1	μA max	
Digital Input Capacitance, C_{IN}	4		pF typ	
DYNAMIC CHARACTERISTICS¹				
Transition Time, $t_{TRANSITION}$	140		ns typ	$R_L = 100\ \Omega$, $C_L = 35\text{ pF}$
	170	240	ns max	$V_S = 10\text{ V}$, see Figure 15
Break-Before-Make Time Delay, t_{BBM}	50		ns typ	$R_L = 100\ \Omega$, $C_L = 35\text{ pF}$
		19	ns min	$V_{S1} = V_{S2} = 10\text{ V}$; see Figure 16
t_{ON} (EN)	100		ns typ	$R_L = 100\ \Omega$, $C_L = 35\text{ pF}$
	120	165	ns max	$V_S = 10\text{ V}$; see Figure 17
t_{OFF} (EN)	100		ns typ	$R_L = 100\ \Omega$, $C_L = 35\text{ pF}$
	120	170	ns max	$V_S = 10\text{ V}$; see Figure 17
Charge Injection	-50		pC typ	$V_S = 0\text{ V}$, $R_S = 0\ \Omega$, $C_L = 1\text{ nF}$; see Figure 18
Off Isolation	-70		dB typ	$R_L = 50\ \Omega$, $C_L = 5\text{ pF}$, $f = 1\text{ MHz}$; see Figure 19
Channel-to-Channel Crosstalk	-70		dB typ	$R_L = 50\ \Omega$, $C_L = 5\text{ pF}$, $f = 1\text{ MHz}$; see Figure 20
Total Harmonic Distortion, THD + N	0.025		% typ	$R_L = 110\ \Omega$, 15 V p-p , $f = 20\text{ Hz to } 20\text{ kHz}$; see Figure 22
-3 dB Bandwidth				$R_L = 50\ \Omega$, $C_L = 5\text{ pF}$; see Figure 21
ADG1408-EP	60		MHz typ	
ADG1409-EP	115		MHz typ	
Insertion Loss	0.24		dB typ	$R_L = 50\ \Omega$, $C_L = 5\text{ pF}$, $f = 1\text{ MHz}$; see Figure 21
C_S (Off)	14		pF typ	$f = 1\text{ MHz}$
C_D (Off)				
ADG1408-EP	80		pF typ	$f = 1\text{ MHz}$
ADG1409-EP	40		pF typ	$f = 1\text{ MHz}$
C_D , C_S (On)				
ADG1408-EP	135		pF typ	$f = 1\text{ MHz}$
ADG1409-EP	90		pF typ	$f = 1\text{ MHz}$

Parameter	+25°C	-55°C to +125°C	Unit	Test Conditions/Comments
POWER REQUIREMENTS				$V_{DD} = +16.5\text{ V}$, $V_{SS} = -16.5\text{ V}$
I_{DD}	0.002	1	$\mu\text{A typ}$ $\mu\text{A max}$	Digital inputs = 0 V or V_{DD}
	220	420	$\mu\text{A typ}$ $\mu\text{A max}$	Digital inputs = 5 V
I_{SS}	0.002	1	$\mu\text{A typ}$ $\mu\text{A max}$	Digital inputs = 0 V, 5 V or V_{DD}
V_{DD}/V_{SS}		$\pm 4.5/\pm 16.5$	V min/max	

¹ Guaranteed by design, not subject to production test.

12 V SINGLE SUPPLY

$V_{DD} = 12\text{ V} \pm 10\%$, $V_{SS} = 0\text{ V}$, $GND = 0\text{ V}$, unless otherwise noted.

Table 2.

Parameter	+25°C	-55°C to +125°C	Unit	Test Conditions/Comments
ANALOG SWITCH				
Analog Signal Range		0 to V_{DD}	V	
On Resistance (R_{ON})	6		Ω typ	$V_S = 0\text{ V to }10\text{ V}$, $I_S = -10\text{ mA}$; see Figure 12
	8	11.2	Ω max	$V_{DD} = 10.8\text{ V}$, $V_{SS} = 0\text{ V}$
On Resistance Match	0.2		Ω typ	$V_S = 0\text{ V to }10\text{ V}$, $I_S = -10\text{ mA}$
Between Channels (ΔR_{ON})	0.82	1.1	Ω max	
On Resistance Flatness ($R_{FLAT(ON)}$)	1.5		Ω typ	$V_S = 0\text{ V to }10\text{ V}$, $I_S = -10\text{ mA}$
	2.5	2.8	Ω max	
LEAKAGE CURRENTS				
Source Off Leakage, I_S (Off)	± 0.04		nA typ	$V_{DD} = 13.2\text{ V}$ $V_S = 1\text{ V}/10\text{ V}$, $V_D = 10\text{ V}/1\text{ V}$; see Figure 13
	± 0.2	± 5	nA max	
Drain Off Leakage, I_D (Off)	± 0.04		nA typ	$V_S = 1\text{ V}/10\text{ V}$, $V_D = 10\text{ V}/1\text{ V}$; see Figure 13
	± 0.45	± 37	nA max	
Channel On Leakage, I_D , I_S (On)	± 0.06		nA typ	$V_S = V_D = 1\text{ V or }10\text{ V}$; see Figure 14
	± 0.44	± 32	nA max	
DIGITAL INPUTS				
Input High Voltage, V_{INH}		2.0	V min	
Input Low Voltage, V_{INL}		0.8	V max	
Input Current	± 0.005		μA typ	$V_{IN} = V_{GND}$ or V_{DD}
		± 0.1	μA max	
Digital Input Capacitance, C_{IN}	5		pF typ	
DYNAMIC CHARACTERISTICS¹				
Transition Time, $t_{TRANSITION}$	200		ns typ	$R_L = 100\ \Omega$, $C_L = 35\text{ pF}$
	260	380	ns max	$V_S = 8\text{ V}$; see Figure 15
Break-Before-Make Time Delay, t_{BBM}	90		ns typ	$R_L = 100\ \Omega$, $C_L = 35\text{ pF}$
		40	ns min	$V_{S1} = V_{S2} = 8\text{ V}$; see Figure 16
t_{ON} (EN)	160		ns typ	$R_L = 100\ \Omega$, $C_L = 35\text{ pF}$
	210	285	ns max	$V_S = 8\text{ V}$; see Figure 17
t_{OFF} (EN)	115		ns typ	$R_L = 100\ \Omega$, $C_L = 35\text{ pF}$
	145	200	ns max	$V_S = 8\text{ V}$; see Figure 17
Charge Injection	-12		pC typ	$V_S = 6\text{ V}$, $R_S = 0\ \Omega$, $C_L = 1\text{ nF}$; see Figure 18
Off Isolation	-70		dB typ	$R_L = 50\ \Omega$, $C_L = 5\text{ pF}$, $f = 1\text{ MHz}$; see Figure 19
Channel-to-Channel Crosstalk	-70		dB typ	$R_L = 50\ \Omega$, $C_L = 5\text{ pF}$, $f = 1\text{ MHz}$; see Figure 20
-3 dB Bandwidth				$R_L = 50\ \Omega$, $C_L = 5\text{ pF}$; see Figure 21
ADG1408-EP	36		MHz typ	
ADG1409-EP	72		MHz typ	
Insertion Loss	0.5		dB typ	$R_L = 50\ \Omega$, $C_L = 5\text{ pF}$, $f = 1\text{ MHz}$; see Figure 21
C_S (Off)	25		pF typ	$f = 1\text{ MHz}$
C_D (Off)				
ADG1408-EP	165		pF typ	$f = 1\text{ MHz}$
ADG1409-EP	80		pF typ	$f = 1\text{ MHz}$
C_D , C_S (On)				
ADG1408-EP	200		pF typ	$f = 1\text{ MHz}$
ADG1409-EP	120		pF typ	$f = 1\text{ MHz}$

Parameter	+25°C	-55°C to +125°C	Unit	Test Conditions/Comments
POWER REQUIREMENTS				$V_{DD} = 13.2\text{ V}$
I_{DD}	0.002		$\mu\text{A typ}$	Digital inputs = 0 V or V_{DD}
	220	1	$\mu\text{A max}$	Digital inputs = 5 V
		420	$\mu\text{A typ}$	
V_{DD}		5/16.5	$\mu\text{A max}$	
			V min/max	$V_{SS} = 0\text{ V}, \text{GND} = 0\text{ V}$

¹ Guaranteed by design, not subject to production test.

5 V DUAL SUPPLY

$V_{DD} = +5\text{ V} \pm 10\%$, $V_{SS} = -5\text{ V} \pm 10\%$, $GND = 0\text{ V}$, unless otherwise noted.

Table 3.

Parameter	+25°C	-55°C to +125°C	Unit	Test Conditions/Comments
ANALOG SWITCH				
Analog Signal Range		V_{SS} to V_{DD}	V	
On Resistance (R_{ON})	7		Ω typ	$V_S = \pm 4.5\text{ V}$, $I_S = -10\text{ mA}$; see Figure 12
	9	12	Ω max	$V_{DD} = +4.5\text{ V}$, $V_{SS} = -4.5\text{ V}$
On Resistance Match Between Channels (ΔR_{ON})	0.3		Ω typ	$V_S = \pm 4.5\text{ V}$, $I_S = -10\text{ mA}$
	0.78	1.1	Ω max	
On Resistance Flatness ($R_{FLAT(ON)}$)	1.5		Ω typ	$V_S = \pm 4.5\text{ V}$; $I_S = -10\text{ mA}$
	2.5	3	Ω max	
LEAKAGE CURRENTS				
Source Off Leakage, I_S (Off)	± 0.02		nA typ	$V_{DD} = +5.5\text{ V}$, $V_{SS} = -5.5\text{ V}$
	± 0.2	± 5	nA max	$V_S = \pm 4.5\text{ V}$, $V_D = \mp 4.5\text{ V}$; see Figure 13
Drain Off Leakage, I_D (Off)	± 0.02		nA typ	$V_S = \pm 4.5\text{ V}$, $V_D = \mp 4.5\text{ V}$; see Figure 13
	± 0.45	± 20	nA max	
Channel On Leakage, I_D , I_S (On)	± 0.04		nA typ	$V_S = V_D = \pm 4.5\text{ V}$; see Figure 14
	± 0.3	± 22	nA max	
DIGITAL INPUTS				
Input High Voltage, V_{INH}		2.0	V min	
Input Low Voltage, V_{INL}		0.8	V max	
Input Current	± 0.005		μA typ	$V_{IN} = V_{GND}$ or V_{DD}
		± 0.1	μA max	
Digital Input Capacitance, C_{IN}	5		pF typ	
DYNAMIC CHARACTERISTICS¹				
Transition Time, $t_{TRANSITION}$	330		ns typ	$R_L = 100\ \Omega$, $C_L = 35\text{ pF}$
	440	550	ns max	$V_S = 5\text{ V}$; see Figure 15
Break-Before-Make Time Delay, t_{BBM}	100		ns typ	$R_L = 100\ \Omega$, $C_L = 35\text{ pF}$
		45	ns min	$V_{S1} = V_{S2} = 5\text{ V}$; see Figure 16
t_{ON} (EN)	245		ns typ	$R_L = 100\ \Omega$, $C_L = 35\text{ pF}$
	330	440	ns max	$V_S = 5\text{ V}$; see Figure 17
t_{OFF} (EN)	215		ns typ	$R_L = 100\ \Omega$, $C_L = 35\text{ pF}$
	285	370	ns max	$V_S = 5\text{ V}$; see Figure 17
Charge Injection	-10		pC typ	$V_S = 0\text{ V}$, $R_S = 0\ \Omega$, $C_L = 1\text{ nF}$; see Figure 18
Off Isolation	-70		dB typ	$R_L = 50\ \Omega$, $C_L = 5\text{ pF}$, $f = 1\text{ MHz}$; see Figure 19
Channel-to-Channel Crosstalk	-70		dB typ	$R_L = 50\ \Omega$, $C_L = 5\text{ pF}$, $f = 1\text{ MHz}$; see Figure 20
Total Harmonic Distortion, THD + N	0.06		% typ	$R_L = 110\ \Omega$, 5 V p-p , $f = 20\text{ Hz to } 20\text{ kHz}$; see Figure 22
-3 dB Bandwidth				$R_L = 50\ \Omega$, $C_L = 5\text{ pF}$; see Figure 21
ADG1408-EP	40		MHz typ	
ADG1409-EP	80		MHz typ	
Insertion Loss	0.5		dB typ	$R_L = 50\ \Omega$, $C_L = 5\text{ pF}$, $f = 1\text{ MHz}$; see Figure 21
C_S (Off)	20		pF typ	$f = 1\text{ MHz}$
C_D (Off)				
ADG1408-EP	130		pF typ	$f = 1\text{ MHz}$
ADG1409-EP	65		pF typ	$f = 1\text{ MHz}$
C_D , C_S (On)				
ADG1408-EP	180		pF typ	$f = 1\text{ MHz}$
ADG1409-EP	120		pF typ	$f = 1\text{ MHz}$

Parameter	+25°C	-55°C to +125°C	Unit	Test Conditions/Comments
POWER REQUIREMENTS				
I_{DD}	0.001	1	$\mu\text{A typ}$ $\mu\text{A max}$	$V_{DD} = +5.5\text{ V}, V_{SS} = -5.5\text{ V}$ Digital inputs = 0 V or V_{DD}
I_{SS}	0.001	1	$\mu\text{A typ}$ $\mu\text{A max}$	Digital inputs = 0 V, 5 V or V_{DD}
V_{DD}/V_{SS}		$\pm 4.5/\pm 16.5$	V min/max	

¹ Guaranteed by design, not subject to production test.

CONTINUOUS CURRENT PER CHANNEL, S OR D

Table 4.

Parameter	25°C	85°C	125°C	Unit	Test Conditions/Comments
CONTINUOUS CURRENT, S or D¹					
15 V Dual Supply					
ADG1408-EP	190	105	50	mA max	$V_{DD} = +13.5\text{ V}, V_{SS} = -13.5\text{ V}$
ADG1409-EP	140	85	45	mA max	
12 V Single Supply					
ADG1408-EP	160	95	50	mA max	$V_{DD} = 10.8\text{ V}, V_{SS} = 0\text{ V}$
ADG1409-EP	120	75	40	mA max	
5 V Dual Supply					
ADG1408-EP	155	90	45	mA max	$V_{DD} = +4.5\text{ V}, V_{SS} = -4.5\text{ V}$
ADG1409-EP	115	70	40	mA max	

¹ Guaranteed by design, not subject to production test.

ABSOLUTE MAXIMUM RATINGS

$T_A = 25^\circ\text{C}$, unless otherwise noted.

Table 5.

Parameter	Rating
V_{DD} to V_{SS}	35 V
V_{DD} to GND	-0.3 V to +25 V
V_{SS} to GND	+0.3 V to -25 V
Analog Inputs, Digital Inputs ¹	$V_{SS} - 0.3\text{ V}$ to $V_{DD} + 0.3\text{ V}$ or 30 mA, whichever occurs first
Continuous Current, S or D	Table 4 data + 10%
Peak Current, S or D (Pulsed at 1 ms, 10% Duty Cycle Maximum)	350 mA
Operating Temperature Range	-55°C to $+125^\circ\text{C}$
Storage Temperature Range	-65°C to $+150^\circ\text{C}$
Junction Temperature	150°C
θ_{JA}	150.4°C/W
θ_{JC}	50°C/W
Lead Temperature, Soldering	
Vapor Phase (60 sec)	215°C
Infrared (15 sec)	220°C

¹ Overvoltages at A, EN, S, or D are clamped by internal diodes. Current should be limited to the maximum ratings given.

Stresses at or above those listed under Absolute Maximum Ratings may cause permanent damage to the product. This is a stress rating only; functional operation of the product at these or any other conditions above those indicated in the operational section of this specification is not implied. Operation beyond the maximum operating conditions for extended periods may affect product reliability.

Only one absolute maximum rating can be applied at any one time.

ESD CAUTION



ESD (electrostatic discharge) sensitive device.

Charged devices and circuit boards can discharge without detection. Although this product features patented or proprietary protection circuitry, damage may occur on devices subjected to high energy ESD. Therefore, proper ESD precautions should be taken to avoid performance degradation or loss of functionality.

PIN CONFIGURATIONS AND FUNCTION DESCRIPTIONS

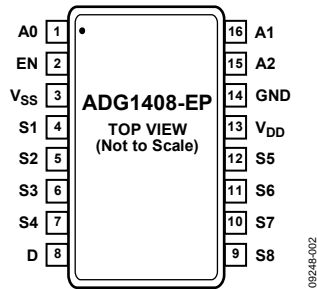

Figure 2. ADG1408-EP Pin Configuration

Table 6. ADG1408-EP Pin Function Descriptions

Pin No.	Mnemonic	Description
1	A0	Logic Control Input.
2	EN	Active High Digital Input. When low, the device is disabled and all switches are off. When high, Ax logic inputs determine on switches.
3	V _{SS}	Most Negative Power Supply Potential. In single supply applications, it can be connected to ground.
4	S1	Source Terminal 1. Can be an input or an output.
5	S2	Source Terminal 2. Can be an input or an output.
6	S3	Source Terminal 3. Can be an input or an output.
7	S4	Source Terminal 4. Can be an input or an output.
8	D	Drain Terminal. Can be an input or an output.
9	S8	Source Terminal 8. Can be an input or an output.
10	S7	Source Terminal 7. Can be an input or an output.
11	S6	Source Terminal 6. Can be an input or an output.
12	S5	Source Terminal 5. Can be an input or an output.
13	V _{DD}	Most Positive Power Supply Potential.
14	GND	Ground (0 V) Reference.
15	A2	Logic Control Input.
16	A1	Logic Control Input.

Table 7. ADG1408-EP Truth Table

A2	A1	A0	EN	On Switch
X	X	X	0	None
0	0	0	1	1
0	0	1	1	2
0	1	0	1	3
0	1	1	1	4
1	0	0	1	5
1	0	1	1	6
1	1	0	1	7
1	1	1	1	8

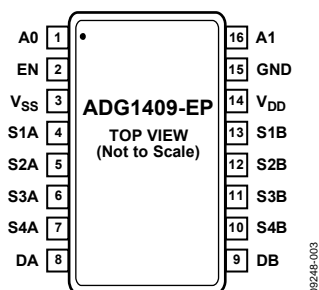

Figure 3. ADG1409-EP Pin Configuration (TSSOP)

Table 8. ADG1409-EP Pin Function Descriptions

Pin No.	Mnemonic	Description
1	A0	Logic Control Input.
2	EN	Active High Digital Input. When low, the device is disabled and all switches are off. When high, Ax logic inputs determine on switches.
3	V _{SS}	Most Negative Power Supply Potential. In single supply applications, it can be connected to ground.
4	S1A	Source Terminal 1A. Can be an input or an output.
5	S2A	Source Terminal 2A. Can be an input or an output.
6	S3A	Source Terminal 3A. Can be an input or an output.
7	S4A	Source Terminal 4A. Can be an input or an output.
8	DA	Drain Terminal A. Can be an input or an output.
9	DB	Drain Terminal B. Can be an input or an output.
10	S4B	Source Terminal 4B. Can be an input or an output.
11	S3B	Source Terminal 3B. Can be an input or an output.
12	S2B	Source Terminal 2B. Can be an input or an output.
13	S1B	Source Terminal 1B. Can be an input or an output.
14	V _{DD}	Most Positive Power Supply Potential.
15	GND	Ground (0 V) Reference.
16	A1	Logic Control Input.

Table 9. ADG1409-EP Truth Table

A1	A0	EN	On Switch Pair
X	X	0	None
0	0	1	1
0	1	1	2
1	0	1	3
1	1	1	4

TYPICAL PERFORMANCE CHARACTERISTICS

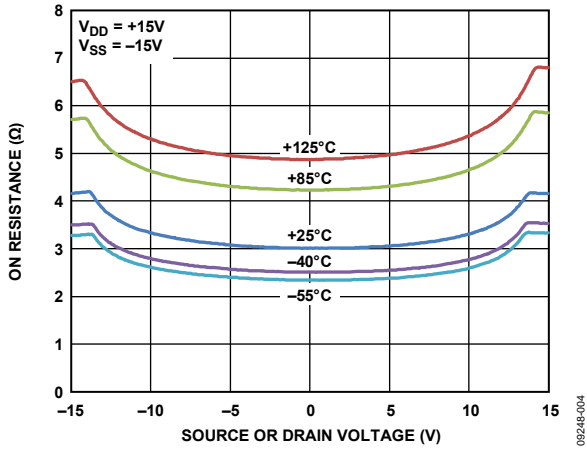

Figure 4. On Resistance vs. V_D , V_S for Different Temperatures; 15 V Dual Supply

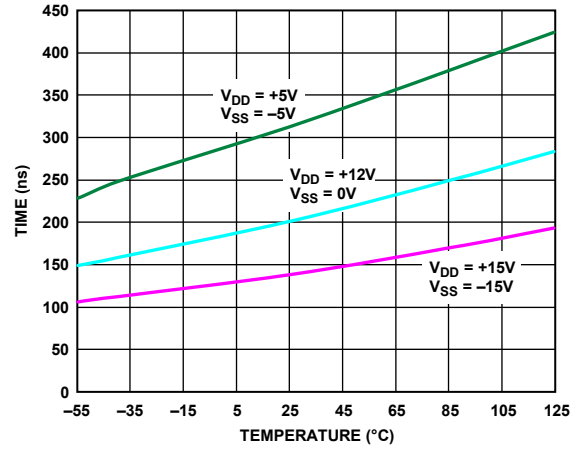

Figure 7. Transition Time vs. Temperature

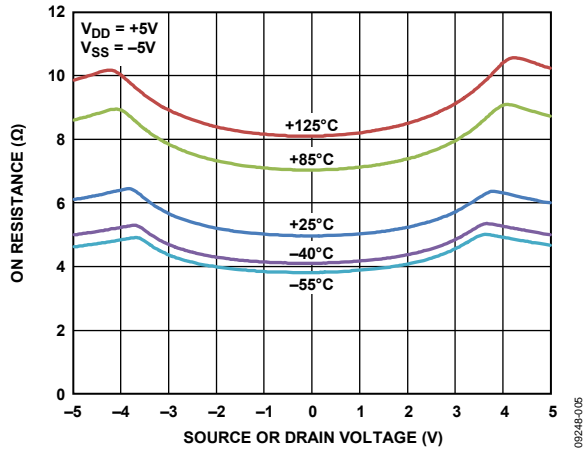

Figure 5. On Resistance vs. V_D , V_S for Different Temperatures; 5 V Dual Supply

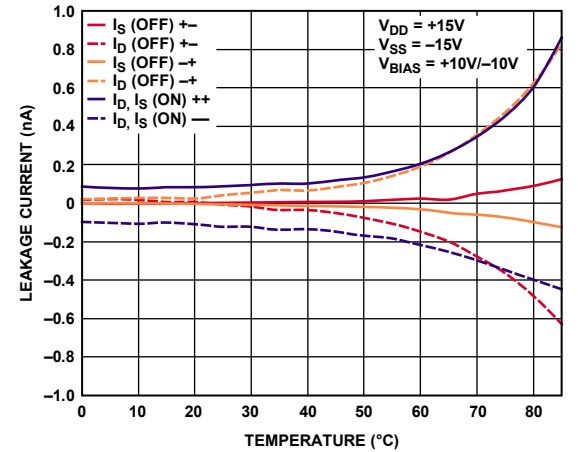

Figure 8. Leakage Current vs. Temperature; 15 V Dual Supply

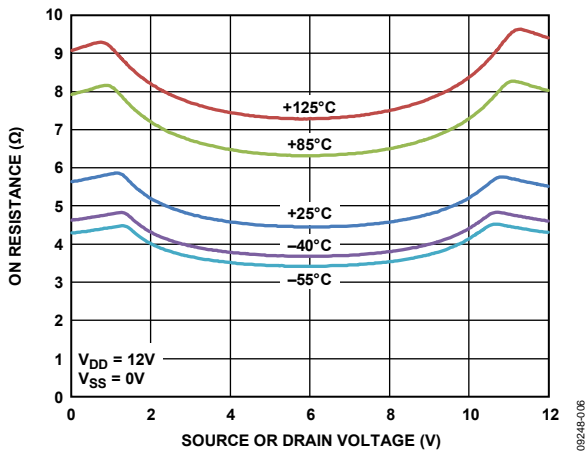

Figure 6. On Resistance vs. V_D , V_S for Different Temperatures; 12 V Single Supply

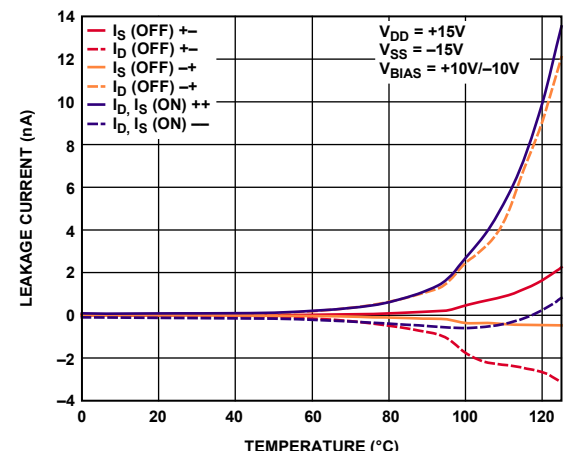

Figure 9. Leakage Current vs. Temperature; 15 V Dual Supply

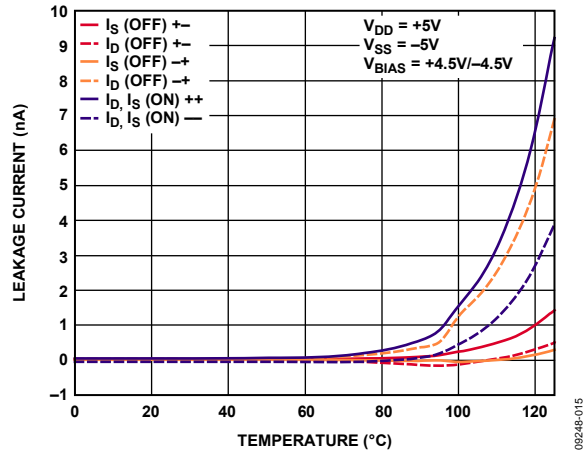

Figure 10. Leakage Current vs. Temperature;
5 V Dual Supply

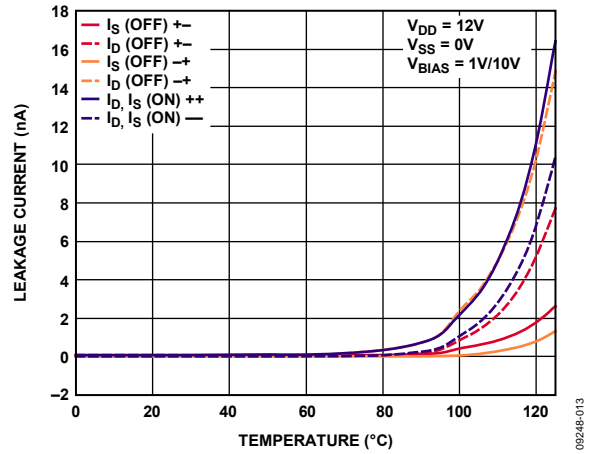

Figure 11. Leakage Current vs. Temperature;
12 V Single Supply

TEST CIRCUITS

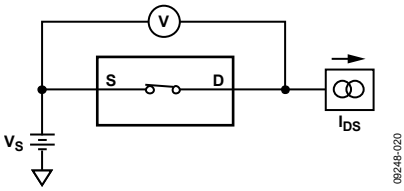

Figure 12. On Resistance

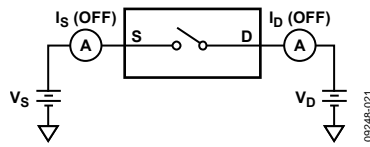

Figure 13. Off Leakage

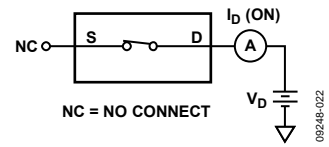

Figure 14. On Leakage

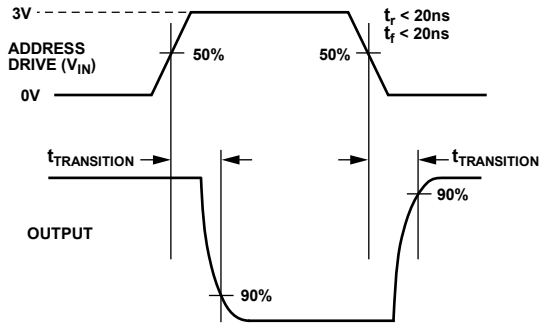
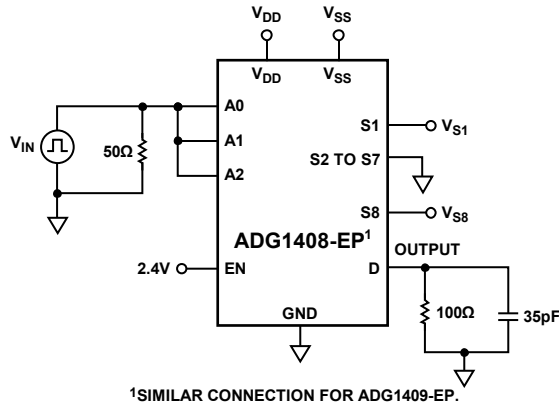

Figure 15. Address to Output Switching Times, $t_{TRANSITION}$



09248-023

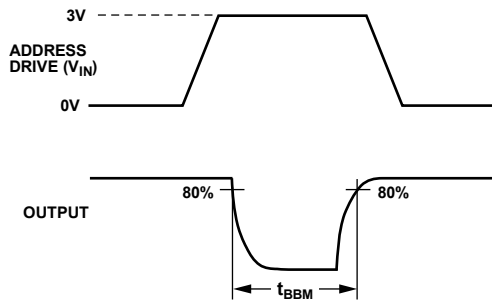
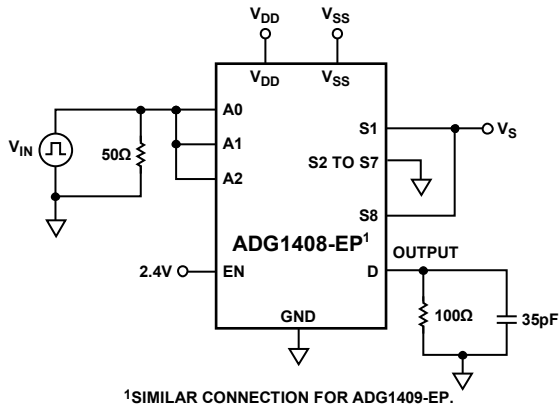

Figure 16. Break-Before-Make Delay, t_{BBM}



09248-024

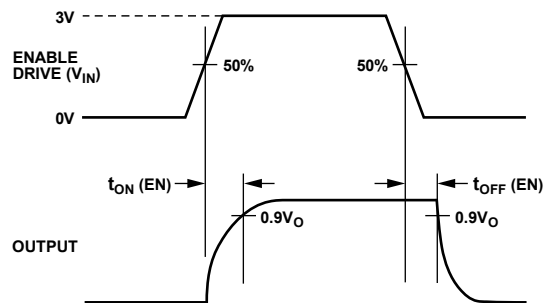
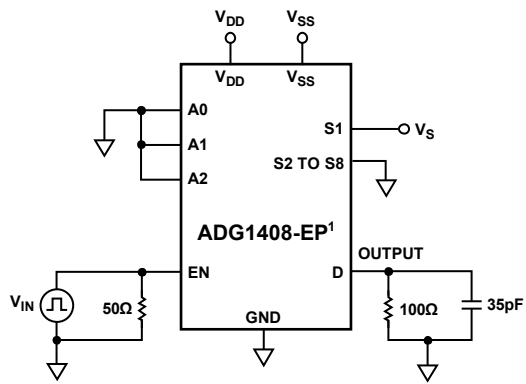

Figure 17. Enable Delay, $t_{ON}(EN)$, $t_{OFF}(EN)$



09248-025

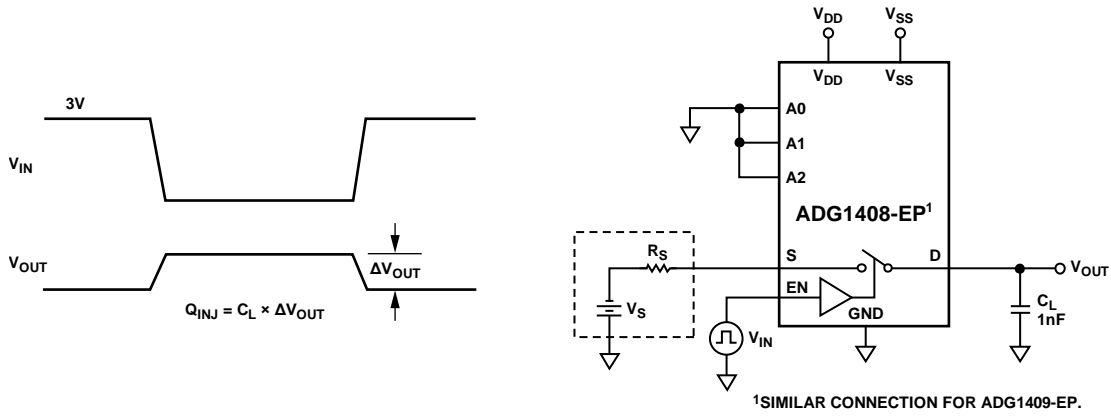

Figure 18. Charge Injection

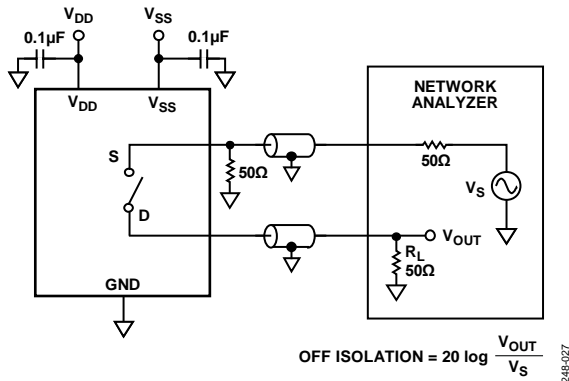

Figure 19. Off Isolation

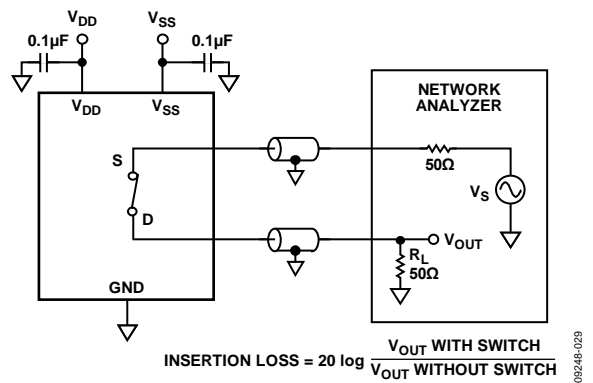

Figure 21. Insertion Loss

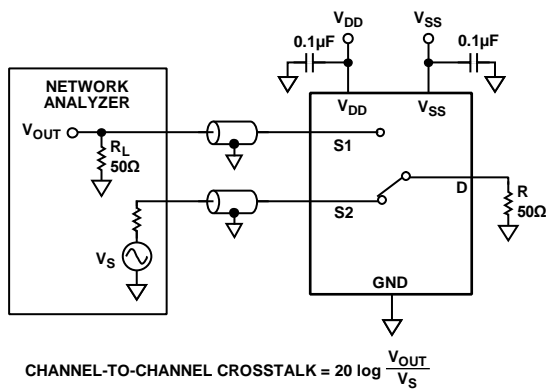

Figure 20. Channel-to-Channel Crosstalk

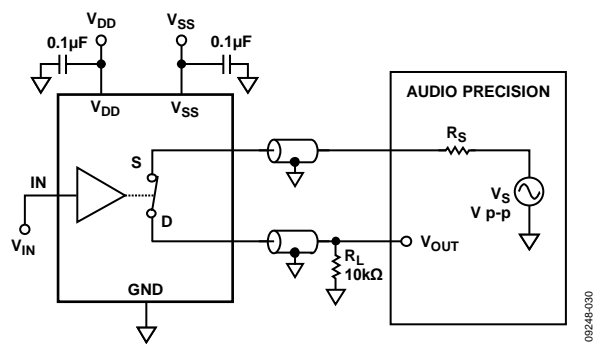
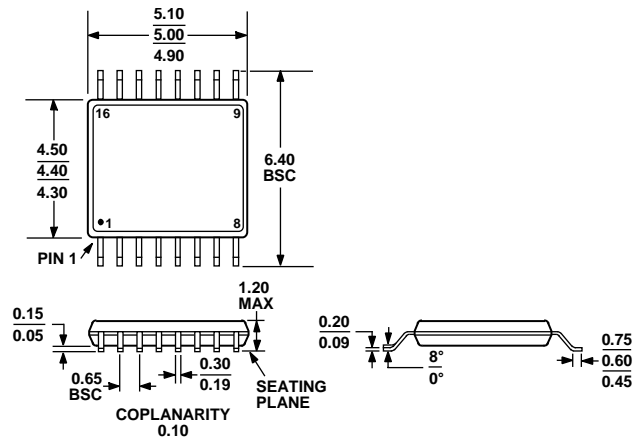

Figure 22. THD + Noise

OUTLINE DIMENSIONS



COMPLIANT TO JEDEC STANDARDS MO-153-AB

Figure 23. 16-Lead Thin Shrink Small Outline Package [TSSOP] (RU-16)

Dimensions shown in millimeters

ORDERING GUIDE

Model ¹	Temperature Range	Package Description	Package Option
ADG1408SRUZ-EP	-55°C to +125°C	16-Lead Thin Shrink Small Outline Package [TSSOP]	RU-16
ADG1408SRUZ-EP-RL7	-55°C to +125°C	16-Lead Thin Shrink Small Outline Package [TSSOP]	RU-16
ADG1408SRU-EP	-55°C to +125°C	16-Lead Thin Shrink Small Outline Package [TSSOP]	RU-16
ADG1408SRU-EP-RL7	-55°C to +125°C	16-Lead Thin Shrink Small Outline Package [TSSOP]	RU-16
ADG1409SRUZ-EP	-55°C to +125°C	16-Lead Thin Shrink Small Outline Package [TSSOP]	RU-16
ADG1409SRUZ-EP-RL7	-55°C to +125°C	16-Lead Thin Shrink Small Outline Package [TSSOP]	RU-16
ADG1409SRU-EP	-55°C to +125°C	16-Lead Thin Shrink Small Outline Package [TSSOP]	RU-16
ADG1409SRU-EP-RL7	-55°C to +125°C	16-Lead Thin Shrink Small Outline Package [TSSOP]	RU-16

¹ Z = RoHS Compliant Part.

X-ON Electronics

Largest Supplier of Electrical and Electronic Components

Click to view similar products for [Multiplexer Switch ICs](#) category:

Click to view products by [Analog Devices](#) manufacturer:

Other Similar products are found below :

[DG508AAK/883B](#) [NLAS5223CMUTAG](#) [DG509ACJ](#) [PI3V512QE](#) [7705201EC](#) [PI2SSD3212NCE](#) [NLAS3257CMX2TCG](#)
[PI3DBS16213ZLEX](#) [PI3DBS16415ZHEX](#) [PI3DBS12412AZHEX](#) [DG407DY](#) [ISL43741IR](#) [ISL43L740IR](#) [ISL54200IRZ](#) [ISL84780IR](#)
[MC74LVX4066DR2](#) [NCN2411MTTWG](#) [NLVHC4052ADTR2G](#) [TMUXHS221NKGR](#) [TMUX7221DGSR](#) [TMUX8213PWR](#) [74HC4052BZX](#)
[ADG1408SRUZ-EP-RL7](#) [ADG1408YRUZ-REEL](#) [ADG1207YRUZ-REEL7](#) [74HC4067PW-Q100J](#) [TMUX2889YBHR](#) [HD3SS213ZXHR](#)
[TMUXHS221NKGT](#) [TMUX131RMGR](#) [TMUX6209PWR](#) [MAX4052AESE+T](#) [MAX306EUI+T](#) [TMUX4827YBHR](#) [TMUXHS4412IRUAR](#)
[TS3DV642RUARQ1](#) [TC7W53FK,LF](#) [74LVC1G3157GM,132](#) [74LVC2G53DC,125](#) [ADG439FBRZ-REEL](#) [PI5V330SQE](#) [CD4053BM96](#)
[CBTL06GP213EEJ](#) [74LVC1G53DC,125](#) [74LVC1G3157GM,115](#) [MAX4634ETB+T](#) [BU4051BCF-E2](#) [BU4052BCFV-E2](#) [BU4551BF-E2](#)
[BU4052BCF-E2](#)