



FEATURES

- Output frequency range: 50 MHz to 2200 MHz**
- 1 dB output compression: 11 dBm @ 350 MHz**
- Noise floor: -160 dBm/Hz @ 350 MHz**
- Sideband suppression: -46 dBc @ 350 MHz**
- Carrier feedthrough: -38 dBm @ 350 MHz**
- 30 dB of linear AGC dynamic range @ 350 MHz**
- Single supply: 4.75 V to 5.5 V**
- 40-lead, Pb-free LFCSP_VQ with exposed paddle**

APPLICATIONS

- Radio-link infrastructures**
- Cable modem termination systems**
- Wireless/cellular infrastructure systems**
- Wireless local loops**
- WiMAX/broadband wireless access systems**

GENERAL DESCRIPTION

The ADL5386 is a quadrature modulator with unmatched integration levels for low intermediate frequency (IF) and radio frequency (RF) transmitters within broadband wireless access systems, microwave radio links, cable modem termination systems, and cellular infrastructure equipment. The ADL5386 operates over a frequency range of 50 MHz to 2200 MHz. Its excellent phase accuracy and amplitude balance supports high data rate, complex modulation for next-generation communication infrastructure equipment.

In addition, the ADL5386 incorporates a standalone logarithmic power detector, as well as a voltage variable attenuator (VVA). The attenuator has its own separate input and output pins for easy cascading with filters and buffer amplifiers. The wide dynamic range of the power detector and VVA provides flexibility in the choice of the signal monitoring point in the transmitter system.

The wide baseband input bandwidth of 700 MHz allows for either baseband drive or a drive from a complex IF signal. Typical applications are in IF or direct-to-RF radio-link transmitters, cable modem termination systems, broadband wireless access systems, and cellular infrastructure equipment.

The ADL5386 takes signals from two differential baseband inputs and modulates them onto two carriers in quadrature with each other. The two internal carriers are derived from a single-ended, external local oscillator (LO) input signal at twice the frequency as the desired output. The output amplifier is designed to drive a 50 Ω load.

The ADL5386 consists of two die, one fabricated using the Analog Devices, Inc., advanced SiGe bipolar process, and the other using an external GaAs process. The ADL5386 is packaged in a 40-lead, Pb-free LFCSP_VQ with an exposed paddle. Performance is specified over the -40°C to +85°C range. A Pb-free evaluation board is also available.

FUNCTIONAL BLOCK DIAGRAM

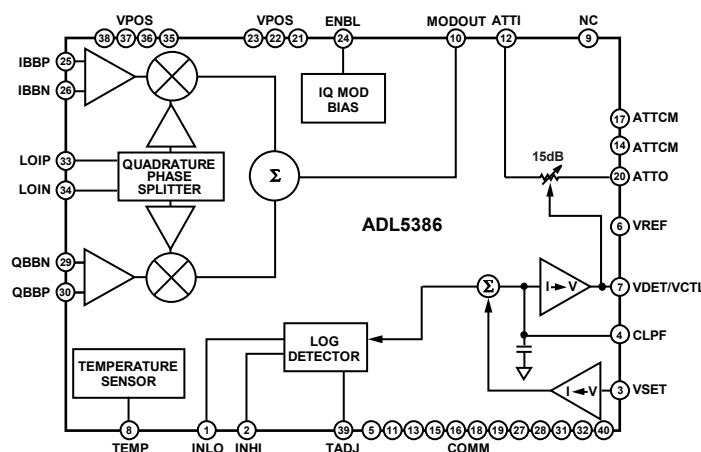

Figure 1.

Rev. 0

Information furnished by Analog Devices is believed to be accurate and reliable. However, no responsibility is assumed by Analog Devices for its use, nor for any infringements of patents or other rights of third parties that may result from its use. Specifications subject to change without notice. No license is granted by implication or otherwise under any patent or patent rights of Analog Devices. Trademarks and registered trademarks are the property of their respective owners.

TABLE OF CONTENTS

Features	1	Open-Loop Power Control Mode	21
Applications	1	Power Supply and Grounding	22
General Description	1	Device Enable and Disable	22
Functional Block Diagram	1	Baseband Inputs	22
Revision History	2	LO Input	22
Specifications	3	AGC Mode	22
Typical Input and Output Impedances	8	Setting the TADJ Resistor	24
Absolute Maximum Ratings	9	Using the Detector in Standalone Measurement Mode	25
ESD Caution	9	DAC Modulator Interfacing	25
Pin Configuration and Function Descriptions	10	Spectral Products from Harmonic Mixing	27
Typical Performance Characteristics	12	LO Generation Using PLLs	27
Modulator	12	Transmit DAC Options	28
Voltage Variable Attenuator	16	Modulator/Demodulator Options	28
Detector	17	Evaluation Board	29
Closed-Loop AGC Mode	18	Characterization Setup	31
Circuit Description	19	SSB Setup	31
Overview	19	Detector Setup	31
Quadrature Modulator Section	19	VVA S-Parameters Setup	32
Logarithmic Detector	20	VVA Intermodulation Test Setup	32
Voltage Variable Attenuator (VVA)	20	Outline Dimensions	33
Basic Connections	21	Ordering Guide	33

REVISION HISTORY

1/09—Revision 0: Initial Version

SPECIFICATIONS

Unless otherwise noted, $V_S = 5\text{ V}$, $T_A = 25^\circ\text{C}$, $LO = -7\text{ dBm}$, I/Q inputs = 1.4 V p-p differential sine waves in quadrature on a 500 mV dc bias, baseband frequency = 1 MHz, LO source and RF output load impedances are 50 Ω .

Table 1.

Parameter	Conditions	Min	Typ	Max	Unit
MODULATOR DYNAMIC CHARACTERISTICS					
Operating Frequency Range		50		2200	MHz
External LO Frequency Range	External LO frequency is twice output frequency	100		4400	MHz
Output Frequency = 50 MHz					
Output Power	Single (lower) sideband output		5.6		dBm
Modulator Voltage Gain			-1.3		dB
Output P1dB			10.8		dBm
Output Return Loss			-21		dB
Carrier Leakage	Unadjusted (nominal drive level)		-43		dBm
	At 85°C after optimization at 25°C		-63		dBm
	At -40°C after optimization at +25°C		-63		dBm
Sideband Suppression	Unadjusted (nominal drive level)		-48		dBc
	At 85°C after optimization at 25°C		-60		dBc
	At -40°C after optimization at +25°C		-60		dBc
Quadrature Error			-0.2		Degrees
I/Q Amplitude Balance			0.05		dB
Second Harmonic	$(f_{LO} - (2 \times f_{BB}))$, $P_{OUT} = 5\text{ dBm}$		-80		dBc
Third Harmonic	$(f_{LO} + (3 \times f_{BB}))$, $P_{OUT} = 5\text{ dBm}$		-58		dBc
Output IP2	F1 = 3.5 MHz, F2 = 4.5 MHz, $P_{OUT} = -3\text{ dBm}$ per tone		76		dBm
Output IP3	F1 = 3.5 MHz, F2 = 4.5 MHz, $P_{OUT} = -3\text{ dBm}$ per tone		26		dBm
Noise Floor	20 MHz offset from LO, all BB inputs at a bias of 500 mV		-159		dBm/Hz
Output Frequency = 140 MHz					
Output Power	Single (lower) sideband output		5.7		dBm
Modulator Voltage Gain			-1.2		dB
Output P1dB			11.1		dBm
Output Return Loss			-21		dB
Carrier Leakage	Unadjusted (nominal drive level)		-42		dBm
	At 85°C after optimization at 25°C		-62		dBm
	At -40°C after optimization at +25°C		-62		dBm
Sideband Suppression	Unadjusted (nominal drive level)		-57		dBc
	At 85°C after optimization at 25°C		-60		dBc
	At -40°C after optimization at +25°C		-60		dBc
Quadrature Error			-0.2		Degrees
I/Q Amplitude Balance			0.05		dB
Second Harmonic	$(f_{LO} - (2 \times f_{BB}))$, $P_{OUT} = 5\text{ dBm}$		-79		dBc
Third Harmonic	$(f_{LO} + (3 \times f_{BB}))$, $P_{OUT} = 5\text{ dBm}$		-56		dBc
Output IP2	F1 = 3.5 MHz, F2 = 4.5 MHz, $P_{OUT} = -3\text{ dBm}$ per tone		75		dBm
Output IP3	F1 = 3.5 MHz, F2 = 4.5 MHz, $P_{OUT} = -3\text{ dBm}$ per tone		25		dBm
Noise Floor	20 MHz offset from LO, all BB inputs at a bias of 500 mV		-160		dBm/Hz
Output Frequency = 350 MHz					
Output Power	Single (lower) sideband output	4	5.5	7	dBm
Modulator Voltage Gain			-1.4		dB
Output P1dB			11.1		dBm
Output Return Loss			-19		dB
Carrier Leakage	Unadjusted (nominal drive level)		-38		dBm
	At 85°C after optimization at 25°C		-58		dBm
	At -40°C after optimization at +25°C		-58		dBm

ADL5386

Parameter	Conditions	Min	Typ	Max	Unit
Sideband Suppression	Unadjusted (nominal drive level)		-46		dBc
	At 85°C after optimization at 25°C		-57		dBc
	At -40°C after optimization at +25°C		-57		dBc
Quadrature Error			-0.5		Degrees
I/Q Amplitude Balance			0.05		dB
Second Harmonic	$(f_{LO} - (2 \times f_{BB}))$, $P_{OUT} = 5$ dBm		-76		dBc
Third Harmonic	$(f_{LO} + (3 \times f_{BB}))$, $P_{OUT} = 5$ dBm		-53		dBc
Output IP2	F1 = 3.5 MHz, F2 = 4.5 MHz, $P_{OUT} = -3$ dBm per tone		74		dBm
Output IP3	F1 = 3.5 MHz, F2 = 4.5 MHz, $P_{OUT} = -3$ dBm per tone		25		dBm
Noise Floor	20 MHz offset from LO, all BB inputs at a bias of 500 mV		-160		dBm/Hz
	20 MHz offset from LO, output power = -5 dBm		-156		dBm/Hz
Output Frequency = 860 MHz					
Output Power	Single (lower) sideband output	3.8	5.3	6.8	dBm
Modulator Voltage Gain			-1.6		dB
Output P1dB			11.4		dBm
Output Return Loss			-15		dB
Carrier Leakage	Unadjusted (nominal drive level)		-37		dBm
	At 85°C after optimization at 25°C		-56		dBm
	At -40°C after optimization at +25°C		-56		dBm
Sideband Suppression	Unadjusted (nominal drive level)		-39		dBc
	At 85°C after optimization at 25°C		-55		dBc
	At -40°C after optimization at +25°C		-55		dBc
Quadrature Error			-0.9		Degrees
I/Q Amplitude Balance			0.05		dB
Second Harmonic	$(f_{LO} - (2 \times f_{BB}))$, $P_{OUT} = 5$ dBm		-72		dBc
Third Harmonic	$(f_{LO} + (3 \times f_{BB}))$, $P_{OUT} = 5$ dBm		-49		dBc
Output IP2	F1 = 3.5 MHz, F2 = 4.5 MHz, $P_{OUT} = -3$ dBm per tone		73		dBm
Output IP3	F1 = 3.5 MHz, F2 = 4.5 MHz, $P_{OUT} = -3$ dBm per tone		25		dBm
Noise Floor	20 MHz offset from LO, all BB inputs at a bias of 500 mV		-160		dBm/Hz
	20 MHz offset from LO, output power = -5 dBm		-157		dBm/Hz
Output Frequency = 1450 MHz					
Output Power	Single (lower) sideband output		4.3		dBm
Modulator Voltage Gain			-2.6		dB
Output P1dB			10.6		dBm
Output Return Loss			-15		dB
Carrier Leakage	Unadjusted (nominal drive level)		-35		dBm
	At 85°C after optimization at 25°C		-50		dBm
	At -40°C after optimization at +25°C		-50		dBm
Sideband Suppression	Unadjusted (nominal drive level)		-43		dBc
	At 85°C after optimization at 25°C		-45		dBc
	At -40°C after optimization at +25°C		-45		dBc
Quadrature Error			-0.2		Degrees
I/Q Amplitude Balance			0.03		dB
Second Harmonic	$(f_{LO} - (2 \times f_{BB}))$, $P_{OUT} = 5$ dBm		-67		dBc
Third Harmonic	$(f_{LO} + (3 \times f_{BB}))$, $P_{OUT} = 5$ dBm		-45		dBc
Output IP2	F1 = 3.5 MHz, F2 = 4.5 MHz, $P_{OUT} = -3$ dBm per tone		63		dBm
Output IP3	F1 = 3.5 MHz, F2 = 4.5 MHz, $P_{OUT} = -3$ dBm per tone		25		dBm
Noise Floor	20 MHz offset from LO, all BB inputs at a bias of 500 mV		-160		dBm/Hz

Parameter	Conditions	Min	Typ	Max	Unit
Output Frequency = 1900 MHz					
Output Power	Single (lower) sideband output		3.2		dBm
Modulator Voltage Gain			-3.7		dB
Output P1dB			9.2		dBm
Output Return Loss			-13		dBm
Carrier Leakage	Unadjusted (nominal drive level)		-35		dBm
	At 85°C after optimization at 25°C		-53		dBm
	At -40°C after optimization at +25°C		-53		dBm
Sideband Suppression	Unadjusted (nominal drive level)		-30		dBc
	At 85°C after optimization at 25°C		-45		dBc
	At -40°C after optimization at +25°C		-45		dBc
Quadrature Error			-3		Degrees
I/Q Amplitude Balance			0.02		dB
Second Harmonic	$(f_{LO} - (2 \times f_{BB}))$, $P_{OUT} = 5$ dBm		-59		dBc
Third Harmonic	$(f_{LO} + (3 \times f_{BB}))$, $P_{OUT} = 5$ dBm		-45		dBc
Output IP2	F1 = 3.5 MHz, F2 = 4.5 MHz, $P_{OUT} = -3$ dBm per tone		55		dBm
Output IP3	F1 = 3.5 MHz, F2 = 4.5 MHz, $P_{OUT} = -3$ dBm per tone		23		dBm
Noise Floor	20 MHz offset from LO, all BB inputs at a bias of 500 mV		-160		dBm/Hz
	20 MHz offset from LO, output power = -5 dBm		-156		dBm/Hz
Output Frequency = 2150 MHz					
Output Power	Single (lower) sideband output		2.5		dBm
Modulator Voltage Gain			-4.4		dB
Output P1dB			8.4		dBm
Output Return Loss			-11		dB
Carrier Leakage	Unadjusted (nominal drive level)		-35		dBm
	At 85°C after optimization at 25°C		-48		dBm
	At -40°C after optimization at +25°C		-46		dBm
Sideband Suppression	Unadjusted (nominal drive level)		-34		dBc
	At 85°C after optimization at 25°C		-45		dBc
	At -40°C after optimization at +25°C		-45		dBc
Quadrature Error			-1.2		Degrees
I/Q Amplitude Balance			0.03		dB
Second Harmonic	$(f_{LO} - (2 \times f_{BB}))$, $P_{OUT} = 5$ dBm		-56		dBc
Third Harmonic	$(f_{LO} + (3 \times f_{BB}))$, $P_{OUT} = 5$ dBm		-48		dBc
Output IP2	F1 = 3.5 MHz, F2 = 4.5 MHz, $P_{OUT} = -3$ dBm per tone		53		dBm
Output IP3	F1 = 3.5 MHz, F2 = 4.5 MHz, $P_{OUT} = -3$ dBm per tone		21		dBm
Noise Floor	20 MHz offset from LO, all BB inputs at a bias of 500 mV		-160		dBm/Hz
	20 MHz offset from LO, output power = -5 dBm		-155		dBm/Hz
LO Inputs	Pin LOIP and Pin LOIN				
LO Drive Level	Characterization performed at typical level	-13	-7	+2	dBm
	Characterization performed at typical level (<140 MHz)	-7	-7	+2	dBm
Input Impedance			50		Ω
Input Return Loss	350 MHz, LOIN ac-coupled to ground		-7		dB
Baseband Inputs	Pin IBBP, Pin IBBN, Pin QBBP, Pin QBBN				
I and Q Input Bias Level			500		mV
Input Bias Current			-60		μ A
Bandwidth (0.1 dB)	$f_{LO} = 2 \times 900$ MHz, $P_{OUT} \approx -4$ dBm		50		MHz
Bandwidth (3 dB)	$f_{LO} = 2 \times 900$ MHz, $P_{OUT} \approx -4$ dBm		700		MHz

ADL5386

Parameter	Conditions	Min	Typ	Max	Unit
VOLTAGE VARIABLE ATTENUATOR					
Pin VCTL, Pin ATTI, and Pin ATTO, open-loop mode, attenuation control applied to VCTL					
Output Frequency = 50 MHz					
Insertion Loss	Minimum attenuation, $V_{VCTL} = 2\text{ V}$		1.7		dB
Attenuation Range	Attenuation at $V_{VCTL} = 2\text{ V}$ – Attenuation at $V_{VCTL} = 0\text{ V}$		37.8		dB
Return Loss			17		dB
Input IP3	Minimum attenuation, $V_{VCTL} = 2\text{ V}$, $\Delta f = 1\text{ MHz}$, input power = -3 dBm per tone		36		dBm
Output Frequency = 140 MHz					
Insertion Loss	Minimum attenuation, $V_{VCTL} = 2\text{ V}$		1.9		dB
Attenuation Range	Attenuation at $V_{VCTL} = 2\text{ V}$ – Attenuation at $V_{VCTL} = 0\text{ V}$		37		dB
Return Loss			17		dB
Input IP3	Minimum attenuation, $V_{VCTL} = 2\text{ V}$, $\Delta f = 1\text{ MHz}$, input power = -3 dBm per tone		36		dBm
Output Frequency = 350 MHz					
Insertion Loss	Minimum attenuation, $V_{VCTL} = 2\text{ V}$		2.2		dB
Attenuation Range	Attenuation at $V_{VCTL} = 2\text{ V}$ – Attenuation at $V_{VCTL} = 0\text{ V}$		26.2		dB
Return Loss			17		dB
Input IP3	Minimum attenuation, $V_{VCTL} = 2\text{ V}$, $\Delta f = 1\text{ MHz}$, input power = -3 dBm per tone		35		dBm
Output Frequency = 860 MHz					
Insertion Loss	Minimum attenuation, $V_{VCTL} = 2\text{ V}$		2.5		dB
Attenuation Range	Attenuation at $V_{VCTL} = 2\text{ V}$ – Attenuation at $V_{VCTL} = 0\text{ V}$		21		dB
Return Loss			14		dB
Input IP3	Minimum attenuation, $V_{VCTL} = 2\text{ V}$, $\Delta f = 1\text{ MHz}$, input power = -3 dBm per tone		35		dBm
Output Frequency = 1900 MHz					
Insertion Loss	Minimum attenuation, $V_{VCTL} = 2\text{ V}$		3		dB
Attenuation Range	Attenuation at $V_{VCTL} = 2\text{ V}$ – Attenuation at $V_{VCTL} = 0\text{ V}$		19		dB
Return Loss			13		dB
Input IP3	Minimum attenuation, $V_{VCTL} = 2\text{ V}$, $\Delta f = 1\text{ MHz}$, input power = -3 dBm per tone		36		dBm
Output Frequency = 2150 MHz					
Insertion Loss	Minimum attenuation, $V_{VCTL} = 2\text{ V}$		3.3		dB
Attenuation Range	Attenuation at $V_{VCTL} = 2\text{ V}$ – Attenuation at $V_{VCTL} = 0\text{ V}$		17		dB
Return Loss			13		dB
Input IP3	Minimum attenuation, $V_{VCTL} = 2\text{ V}$, $\Delta f = 1\text{ MHz}$, input power = -3 dBm per tone		35		dBm
SWITCHING CHARACTERISTICS					
VCTL Response Time	ATTCM (Pin 14 and Pin 17) = 1000 pF				
	Frequency = 350 MHz, $V_{VCTL} = 2\text{ V}$ to 0 V; measured from 50 % of V_{VCTL} to 10% of RF envelope		125		ns
	Frequency = 350 MHz, $V_{VCTL} = 0\text{ V}$ to 2 V; measured from 50 % of V_{VCTL} to 90% of RF envelope		15		ns
LOG DETECTOR					
In measurement mode, VDET/VCTL is shorted to VSET; in controller mode, the setpoint voltage is applied to VSET; the CW input signal is applied at INHI					
f = 50 MHz	$R_{TADJ} = 22.1\text{ k}\Omega$				
$\pm 1\text{ dB}$ Dynamic Range	$T_A = 25^\circ\text{C}$		28		dB
Slope ¹			-21		mV/dB
Intercept ¹			18.2		dBm
VDET or VSET Voltage	$P_{IN} = -10\text{ dBm}$		0.59		V
	$P_{IN} = -30\text{ dBm}$		1.01		V

Parameter	Conditions	Min	Typ	Max	Unit
f = 140 GHz	R _{TADJ} = 22.1 kΩ				
±1 dB Dynamic Range	T _A = 25°C		28		dB
Slope ¹			-21.1		mV/dB
Intercept ¹			17.8		dBm
VDET or VSET Voltage	P _{IN} = -10 dBm		0.59		V
	P _{IN} = -30 dBm		1.01		V
f = 350 MHz	R _{TADJ} = 22.1 kΩ				
±1 dB Dynamic Range	T _A = 25°C		26		dB
Slope ¹			-21.3		mV/dB
Intercept ¹			17.1		dBm
VDET or VSET Voltage	P _{IN} = -10 dBm		0.58		V
	P _{IN} = -30 dBm		1.0		V
f = 860 MHz	R _{TADJ} = 22.1 kΩ				
±1 dB Dynamic Range	T _A = 25°C		25		dB
Slope ¹			-21.6		mV/dB
Intercept ¹			16.2		dBm
VDET or VSET Voltage	P _{IN} = -10 dBm		0.57		V
	P _{IN} = -30 dBm		1.00		V
f = 1900 MHz	R _{TADJ} = 22.1 kΩ				
±1 dB Dynamic Range	T _A = 25°C		26		dB
Slope ¹			-22.7		mV/dB
Intercept ¹			13.5		dBm
VDET or VSET Voltage	P _{IN} = -10 dBm		0.54		V
	P _{IN} = -30 dBm		0.99		V
f = 2150 MHz	R _{TADJ} = 22.1 kΩ				
±1 dB Dynamic Range	T _A = 25°C		24		dB
Slope ¹			-23.2		mV/dB
Intercept ¹			12.6		dBm
VDET or VSET Voltage	P _{IN} = -10 dBm		0.53		V
	P _{IN} = -30 dBm		0.99		V
LOG DETECTOR OUTPUT INTERFACE	VDET				
VDET Voltage Swing	V _{VSET} = 0 V, INHI = open, controller mode		2		V
	V _{VSET} = 2 V, INHI = open, controller mode		10		mV
Small Signal Bandwidth	Simulated, INHI = -10 dBm, from CLPF to VOUT		>100		MHz
Output Noise	INHI = 2.2 GHz, -10 dBm, f _{NOISE} = 100 kHz, C _{CLPF} = open		73		nV/√Hz
Fall Time	Input level = no signal to -10 dBm, 90% to 10%, C _{CLPF} = 8 pF		42		ns
	Input level = no signal to -10 dBm, 90% to 10%, C _{CLPF} = 0.1 μF		178		μs
Rise Time	Input level = -10 dBm to no signal, 10% to 90%, C _{CLPF} = 8 pF		29		ns
	Input level = -10 dBm to no signal, 10% to 90%, C _{CLPF} = 0.1 μF		174		μs
Video Bandwidth			15		MHz
VSET Incremental Input Resistance	P _{OUT} = 0 dBm, AGC mode, V _{VSET} = 0.9 V to 1 V		33,000		dV/dI
VSET Input Bias Current	P _{OUT} = 0 dBm, AGC mode, V _{VSET} = 1 V		25		μA
TADJ INTERFACE	TADJ				
Input Resistance	TADJ = 0.9 V, sourcing 50 μA		13		kΩ
Disable Threshold Voltage	TADJ = open		V _{VPOS} - 0.4		V
TEMPERATURE SENSOR OUTPUT	TEMP				
Output Voltage	T _A = 27.15°C, 300K, R _L = 1 MΩ (after full warmup)		1.45		V
Temperature Slope	-40°C ≤ T _A ≤ +85°C, R _L = 1 MΩ		4.6		mV/°C
Output Impedance			1		kΩ

ADL5386

Parameter	Conditions	Min	Typ	Max	Unit
ENABLE INPUT	ENBL				
Input Bias Current	ENBL = 5 V		0.5		μA
	ENBL = 0 V		-0.7		μA
ENBL High Level (Logic 1)		1.5			V
ENBL Low Level (Logic 0)				0.4	V
POWER SUPPLIES	Pin VPOS				
Voltage		4.75		5.5	V
Supply Current	ENBL = high		230	245	mA
	In sleep mode, ENBL = low and TADJ = high		2.2		mA
	In detector disabled mode, ENBL = high and TADJ = high		215		mA

¹ Slope and intercept are determined by calculating the best-fit line between the power levels of -33 dBm and -10 dBm at the specified input frequency.

TYPICAL INPUT AND OUTPUT IMPEDANCES

Unless otherwise noted, $V_S = 5\text{ V}$, $T_A = 25^\circ\text{C}$. All impedances are normalized to $50\ \Omega$. The effects of the test fixture are de-embedded up to the pins of the device.

Table 2.

Frequency (MHz)	LO Input Impedance at 2× Frequency	Modulator Output Impedance	Detector Input Impedance
50	1.393 - j0.027	0.847 - j0.016	28.463 - j11.386
140	1.406 + j0.013	0.839 + j0.019	15.159 - j15.234
350	1.441 + j0.039	0.82 + j0.065	4.661 - j10.6
860	1.66 + j0.077	0.764 + j0.166	1.158 - j4.58
1450	2.261 - j0.304	0.799 + j0.231	0.567 - j2.545
1900	1.436 - j1.898	0.856 + j0.371	0.375 - j1.866
2150	0.517 - j1.446	0.862 + j0.51	0.308 - j1.652

ABSOLUTE MAXIMUM RATINGS

Table 3.

Parameter	Rating
Supply Voltage, VPOS	5.5 V
IBBP, IBBN, QBBP, QBBN Range	0 V to 2.0 V
LOIP and LOIN	13 dBm
Internal Power Dissipation	1.4 W
θ_{JA} (Exposed Paddle Soldered Down)	38°C/W
Maximum Junction Temperature	150°C
Operating Temperature Range	-40°C to +85°C
Storage Temperature Range	-65°C to +150°C

Stresses above those listed under Absolute Maximum Ratings may cause permanent damage to the device. This is a stress rating only; functional operation of the device at these or any other conditions above those indicated in the operational section of this specification is not implied. Exposure to absolute maximum rating conditions for extended periods may affect device reliability.

ESD CAUTION



ESD (electrostatic discharge) sensitive device.

Charged devices and circuit boards can discharge without detection. Although this product features patented or proprietary protection circuitry, damage may occur on devices subjected to high energy ESD. Therefore, proper ESD precautions should be taken to avoid performance degradation or loss of functionality.

PIN CONFIGURATION AND FUNCTION DESCRIPTIONS

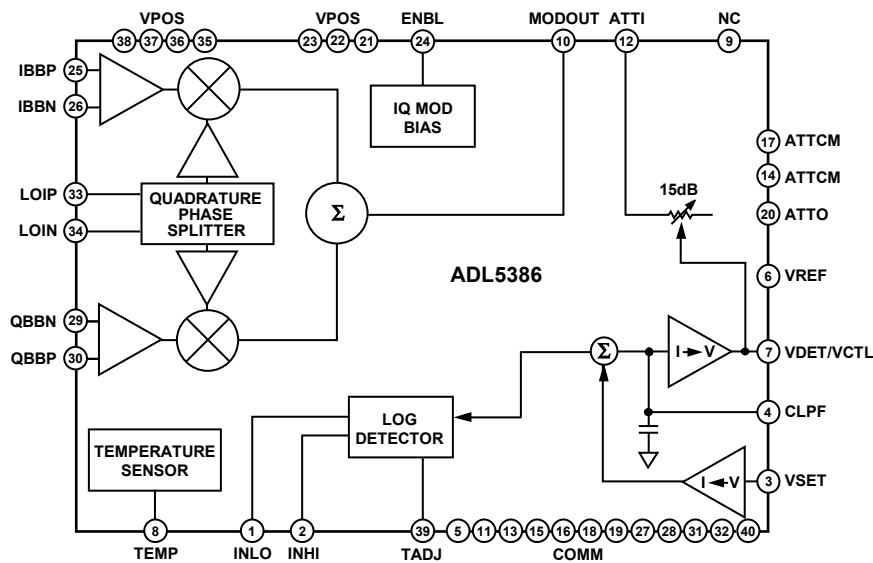

- NOTES**
 1. NC = NO CONNECT.
 2. CONNECT THE EXPOSED PAD TO GROUND VIA A LOW IMPEDANCE PATH.

Figure 2. Pin Configuration

07864-002

Table 4. Pin Function Descriptions

Pin No.	Mnemonic	Description
1	INLO	Detector Common. This pin should be ac-coupled to ground.
2	INH1	Detector Input. When operating in AGC mode, a portion of the signal at the output of the VVA (or at the output of a subsequent stage) is coupled back to this input. The signal should be ac-coupled into INHI. To provide a 50 Ω match at INHI, a 50 Ω resistor should be connected between INHI and ground (with the ac-coupling capacitor placed between the resistor and the INHI pin).
3	VSET	Setpoint Input. Setpoint input for controller mode or feedback input for measurement mode.
4	CLPF	AGC Loop Filter Capacitor. The ground-referenced capacitor that is connected to this pin sets the loop bandwidth of the AGC circuit.
5, 11, 13, 15, 16, 18, 19, 27, 28, 31, 32, 40	COMM	Device Common. Connect these pins to the same low impedance ground plane.
6	VREF	Attenuator Control Voltage Reference. In AGC mode, this pin should be left open. In open-loop mode, when the VVA is being controlled externally, a 2 V reference voltage should be applied to this pin.
7	VDET/VCTL	Detector Output/VVA Control Voltage Input. When the VVA is being controlled externally (open-loop mode), the attenuation is controlled by the external voltage applied to this pin. The VVA control range is from 0 V (maximum attenuation) to 2 V (minimum attenuation). In this mode, VREF (Pin 6) should be tied to approximately 2 V. When the VVA is being operated in AGC mode, this pin is left open with the voltage on the pin representing the AGC drive voltage to the VVA. If the VVA is not being used, the AGC log amp can be used as a standalone detector by connecting this pin to VSET. In this mode, the log amp output voltage is available at this pin.
8	TEMP	Temperature Sensor Output. This pin provides a standalone temperature sensor output voltage. At room temperature, the nominal output voltage is equal to 1.45 V. The slope of the output voltage is equal to 4.6 mV/°C.
9	NC	No Connect. Do not connect this pin.
10	MODOUT	RF Output of IQ Modulator. Single-ended, 50 Ω internally biased RF output. MODOUT is generally ac-coupled to the input of the VVA (either ATTI or ATTO).
12, 20	ATTI, ATTO	VVA RF Input/Output. ATTI is normally ac-coupled to MODOUT. However, because the VVA is completely reversible, MODOUT can also drive ATTO with ATTI operating as the VVA output.
14, 17	ATTCM	VVA Input/Output Common. These pins should be ac-coupled to ground.
21 to 23, 35 to 38	VPOS	Power Supply. Positive supply voltage pins. All pins should be connected to the same supply (VS). To ensure adequate external bypassing, connect a 0.1 μF capacitor between each pin and ground.

Pin No.	Mnemonic	Description
24	ENBL	IQ Modulator Enable. The IQ modulator is enabled by connecting this pin to VPOS and is disabled by connecting ENBL to ground.
25, 26, 29, 30	IBBP, IBBN, QBPN, QBPN	Differential In-Phase and Quadrature Baseband Inputs. These high impedance inputs should be dc-biased to 0.5 V. Nominal characterized ac signal swing is 700 mV p-p on each pin, resulting in a differential drive of 1.4 V p-p on each input pair. These inputs are not self-biased and have to be externally biased.
33	LOIP	Local Oscillator Input. The local oscillator signal, at two times the output frequency, should be ac-coupled into this pin.
34	LOIN	Local Oscillator Common. This pin should be ac-coupled to ground.
39	TADJ	Temperature Compensation Adjustment Pin and Detector Enable/Disable. This pin is primarily used to provide temperature compensation to the on-chip log amp based AGC circuit. The correct compensation current is set by connecting a ground-referenced resistor to this pin. A value of 22.1 k Ω is recommended for the frequencies over which the ADL5386 is specified. The TADJ pin can also be used to power down the detector section of the ADL5386 by connecting it to VPOS. The detector must be disabled when the modulator/VVA is operating in open loop mode.
41 (EPAD)	Exposed Pad (EPAD)	Connect the exposed pad to ground via a low impedance path.

TYPICAL PERFORMANCE CHARACTERISTICS

MODULATOR

Unless otherwise noted, $V_S = 5\text{ V}$, $T_A = 25^\circ\text{C}$, $LO = -7\text{ dBm}$, I/Q inputs = 1.4 V p-p differential sine waves in quadrature on a 500 mV dc bias, baseband frequency = 1 MHz, LO source and RF output load impedances are 50 Ω .

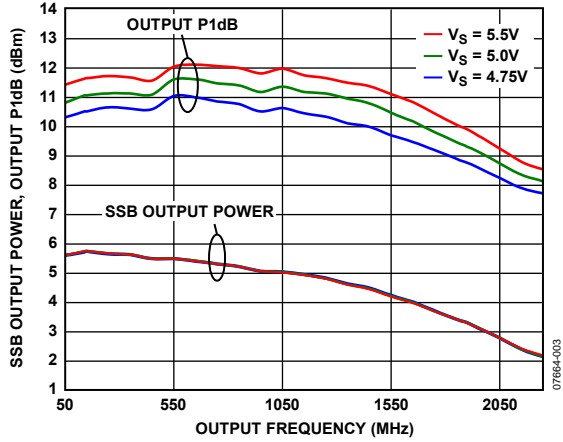

Figure 3. Single Sideband (SSB) Output Power (P_{OUT}), Output P 1 dB vs. Output Frequency and Power Supply

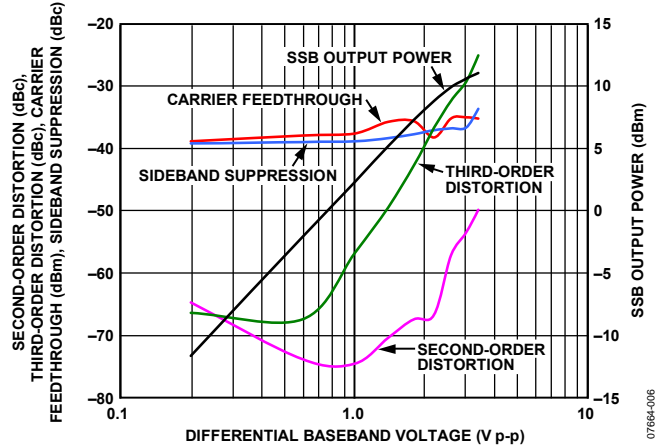

Figure 6. Second- and Third-Order Distortion, Carrier Feedthrough, Sideband Suppression, and SSB Output Power vs. Differential Baseband Voltage, Output Frequency = 860 MHz

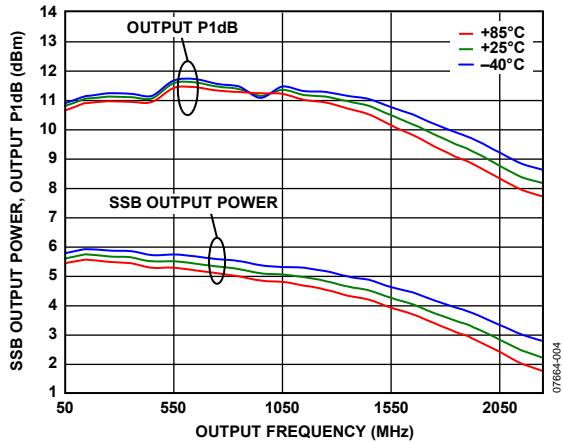

Figure 4. Single Sideband (SSB) Output Power (P_{OUT}), Output P 1 dB vs. Output Frequency and Temperature

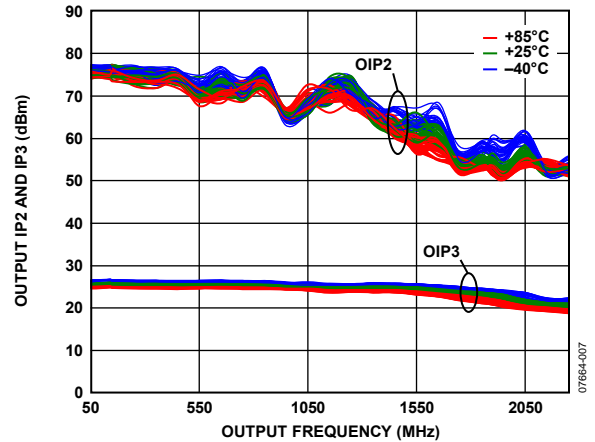

Figure 7. Output IP2 and IP3 vs. Output Frequency and Temperature

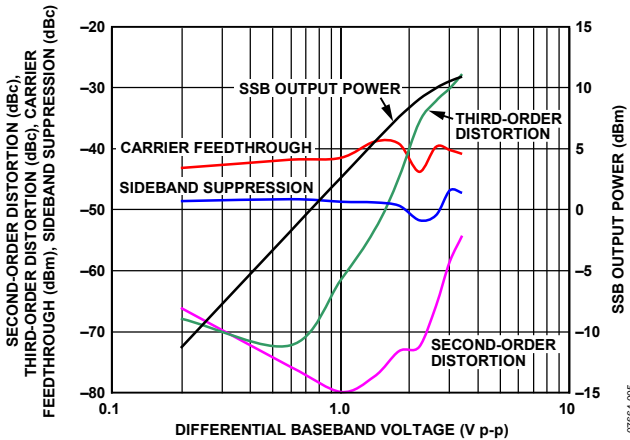

Figure 5. Second- and Third-Order Distortion, Carrier Feedthrough, Sideband Suppression, and SSB Output Power vs. Differential Baseband Voltage, Output Frequency = 350 MHz

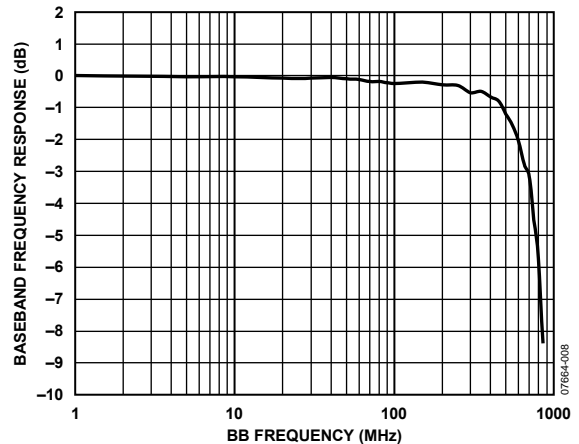

Figure 8. Baseband Frequency Response Normalized to Response for 1 MHz BB Signal, Carrier Frequency = 500 MHz

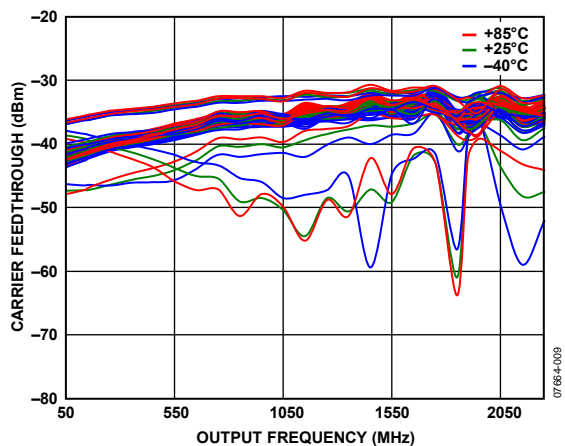

Figure 9. Carrier Feedthrough Distribution vs. Output Frequency and Temperature

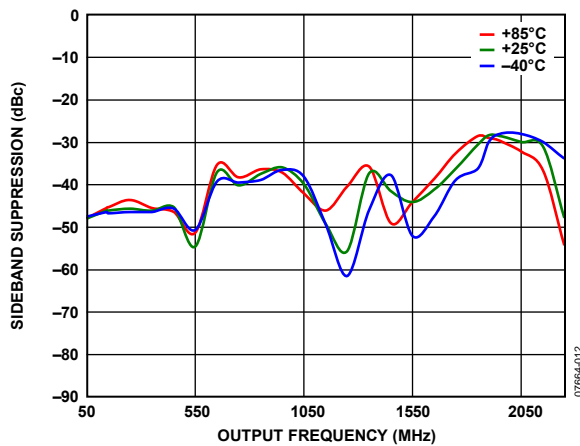

Figure 12. Sideband Suppression vs. Output Frequency and Temperature

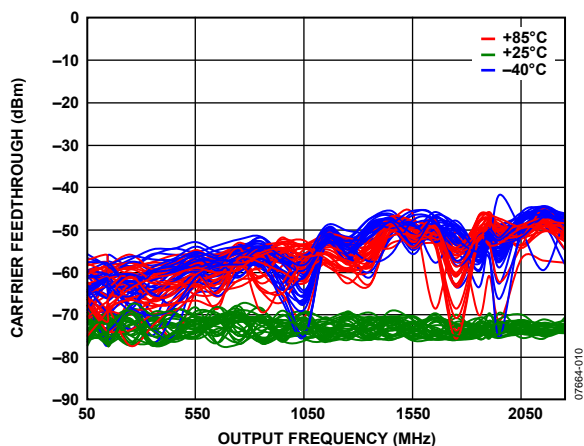

Figure 10. Carrier Feedthrough Distribution at Temperature Extremes, After Nulling to < -65 dBm at $T_A = 25^\circ\text{C}$ vs. Output Frequency

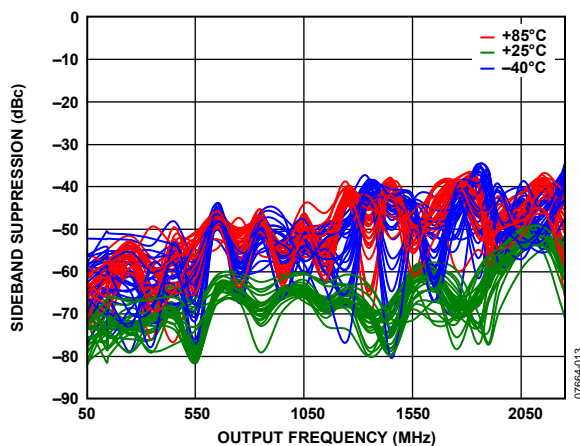

Figure 13. Sideband Suppression Distribution at Temperature Extremes, After Sideband Suppression Nulled to < -50 dBc at $T_A = 25^\circ\text{C}$ vs. Output Frequency

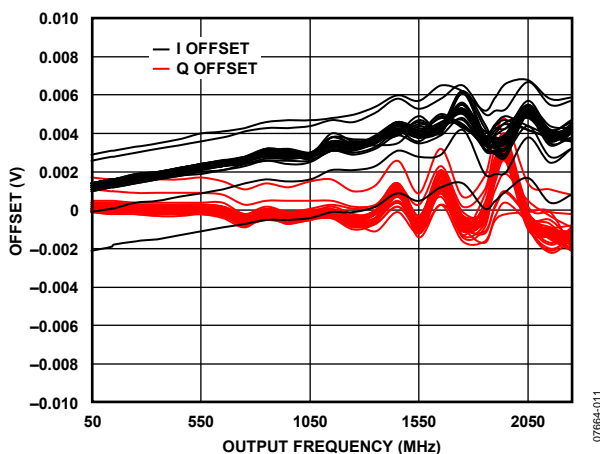

Figure 11. Distribution of I Offset and Q Offset Required to Null Carrier Feedthrough vs. Output Frequency

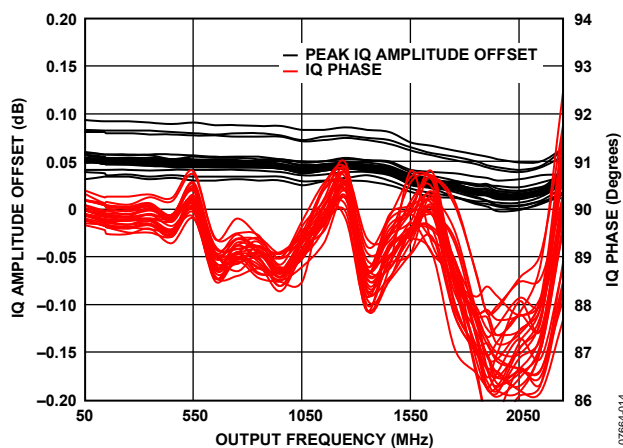

Figure 14. Distribution of Peak Q Amplitude to Null Undesired Sideband (Peak I Amplitude Held Constant at 0.7 V) and Distribution of IQ Phase to Null Undesired Sideband vs. Output Frequency

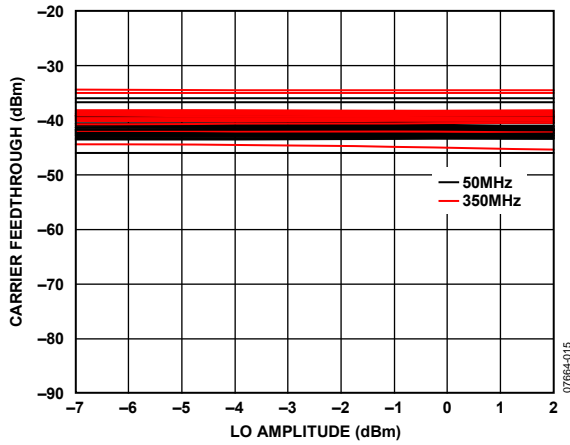

Figure 15. Carrier Feedthrough Distribution vs. LO Amplitude at 50 MHz and 350 MHz

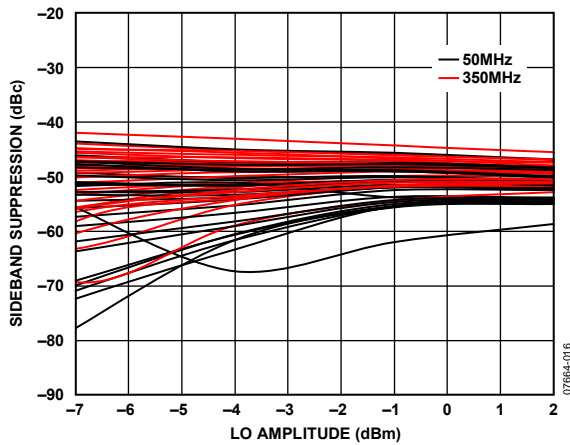

Figure 16. Sideband Suppression Distribution vs. LO Amplitude at 50 MHz and 350 MHz

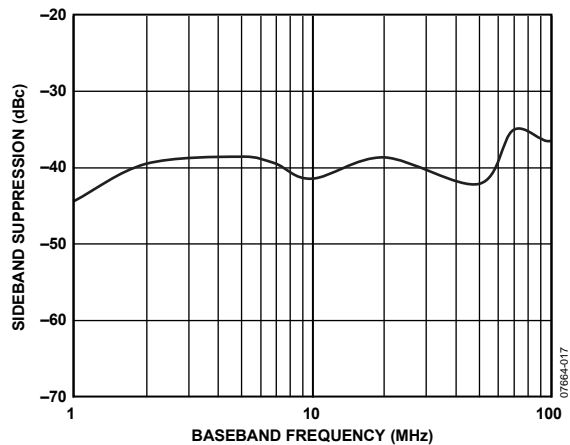

Figure 17. Sideband Suppression vs. Baseband Frequency, Output Frequency = 350 MHz

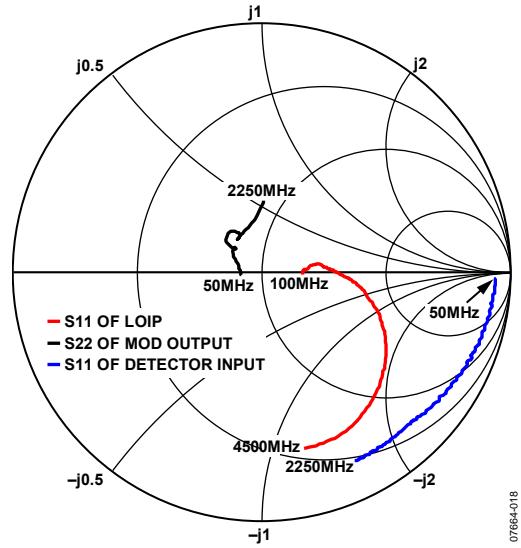

Figure 18. Modulator Output Impedance, LO Input Impedance and Detector Input Impedance (Unterminated) vs. Frequency

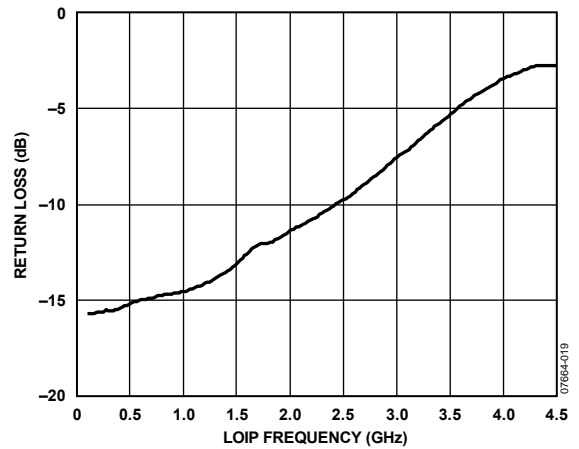

Figure 19. LO Port Input Return Loss vs. LOIP Frequency

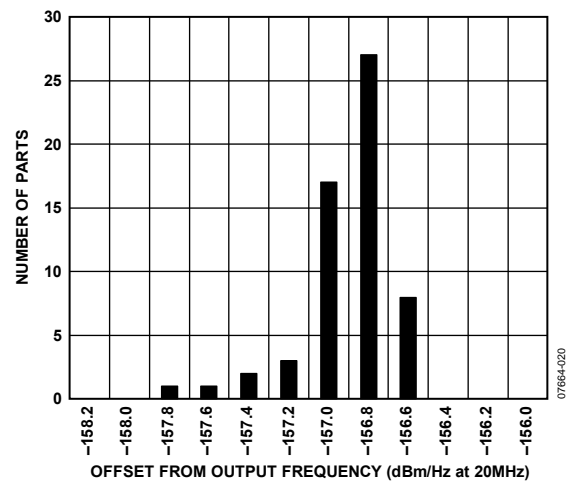

Figure 20. 20 MHz Offset Noise Floor Distribution, Output Frequency = 360 MHz, $P_{out} = -5$ dBm, QPSK Carrier, Symbol Rate = 3.84 MS/PS

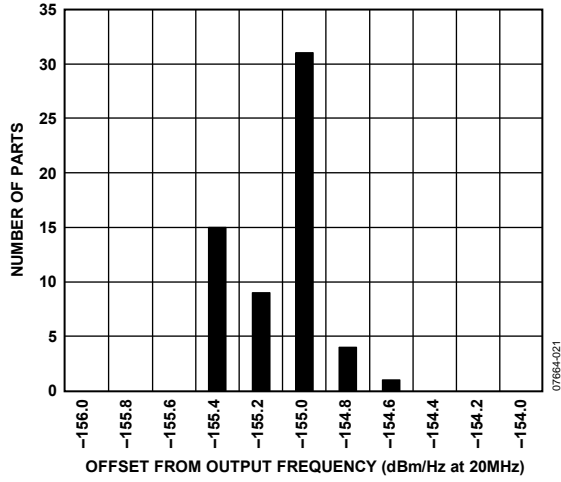

Figure 21. 20 MHz Offset Noise Floor Distribution, Output Frequency = 860 MHz, $P_{OUT} = -5$ dBm, 64 QAM Carrier, Symbol Rate = 5 MSPS

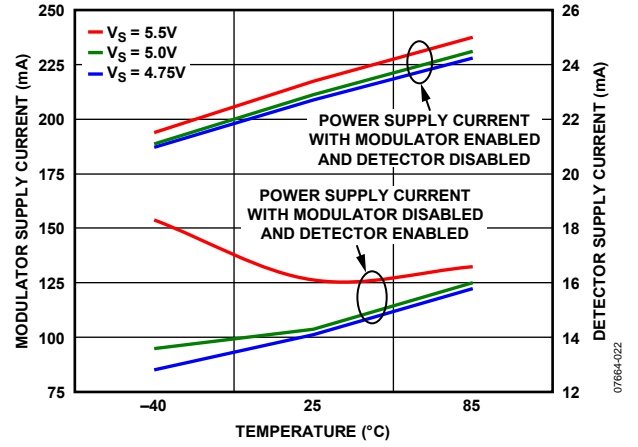

Figure 22. Power Supply Current vs. Temperature and Supply Voltage

VOLTAGE VARIABLE ATTENUATOR

Unless otherwise noted, $V_S = 5\text{ V}$, $T_A = 25^\circ\text{C}$.

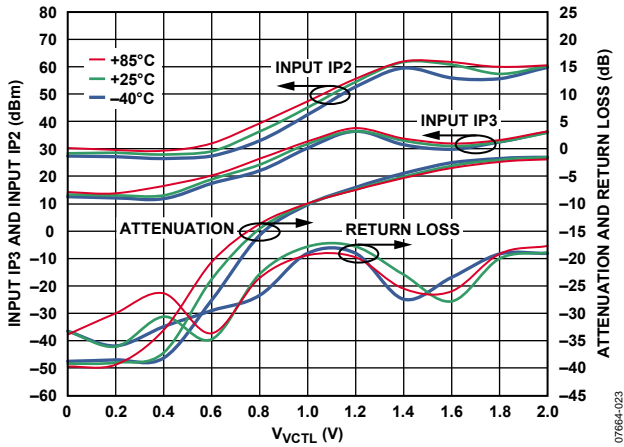

Figure 23. IIP3, IIP2, Attenuation, and Return Loss vs. V_{VCTL} Voltage and Temperature at 140 MHz

07864-023

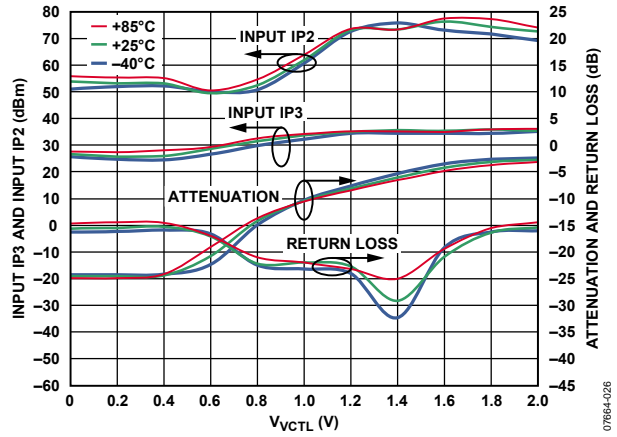

Figure 26. IIP3, IIP2, Attenuation, and Return Loss vs. V_{VCTL} Voltage and Temperature at 1450 MHz

07864-026

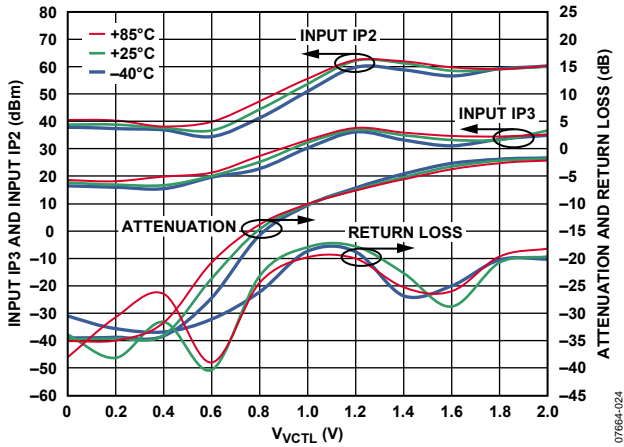

Figure 24. IIP3, IIP2, Attenuation, and Return Loss vs. V_{VCTL} Voltage and Temperature at 350 MHz

07864-024

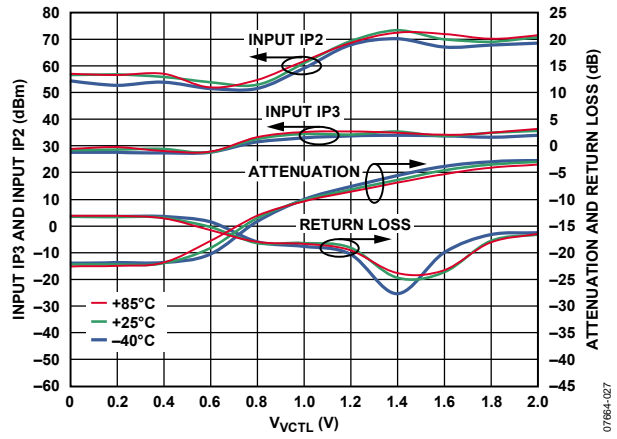

Figure 27. IIP3, IIP2, Attenuation, and Return Loss vs. V_{VCTL} Voltage and Temperature at 1900 MHz

07864-027

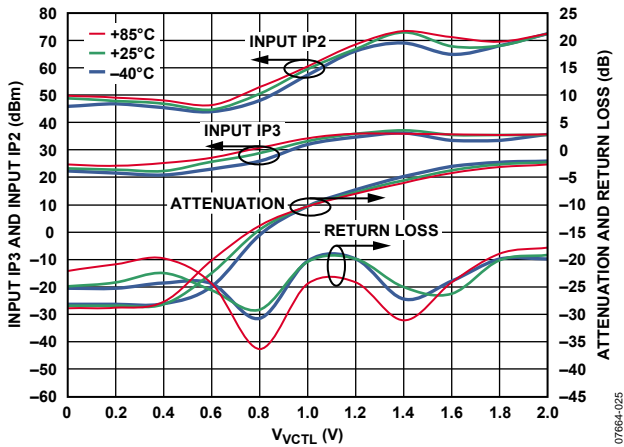

Figure 25. IIP3, IIP2, Attenuation, and Return Loss vs. V_{VCTL} Voltage and Temperature at 860 MHz

07864-025

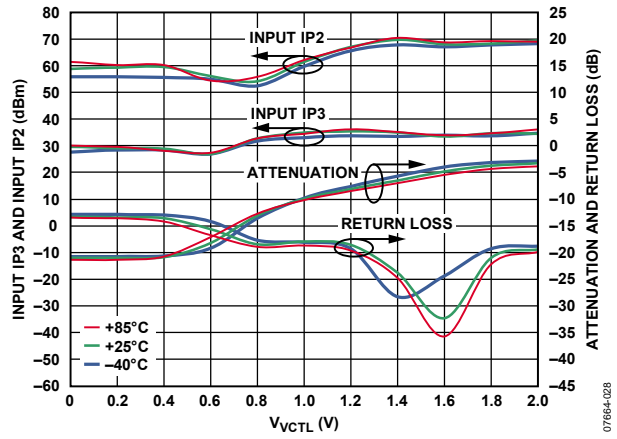

Figure 28. IIP3, IIP2, Attenuation, and Return Loss vs. V_{VCTL} Voltage and Temperature at 2150 MHz

07864-028

DETECTOR

Unless otherwise noted, $V_S = 5\text{ V}$, $T_A = 25^\circ\text{C}$.

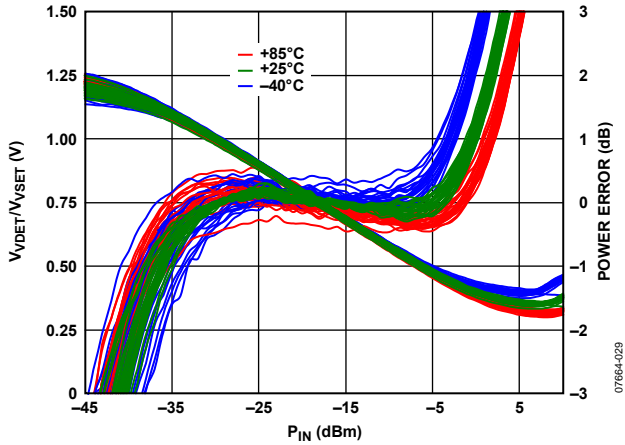

Figure 29. V_{VDET}/V_{VSET} Voltage and Log Conformance vs. Input Amplitude at 350 MHz, $R_{TADJ} = 22.1\text{ k}\Omega$

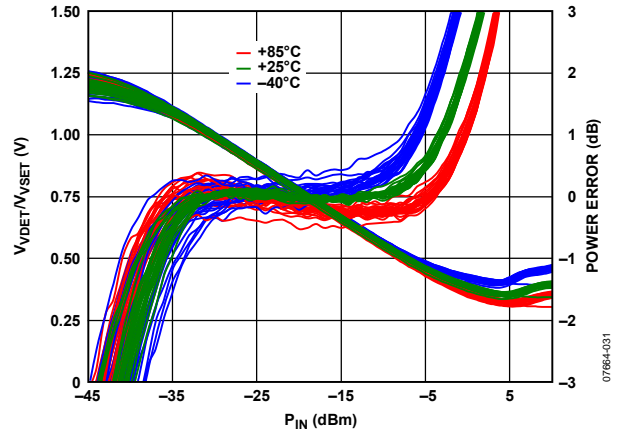

Figure 31. V_{VDET}/V_{VSET} Voltage and Log Conformance vs. Input Amplitude at 1450 MHz, $R_{TADJ} = 22.1\text{ k}\Omega$

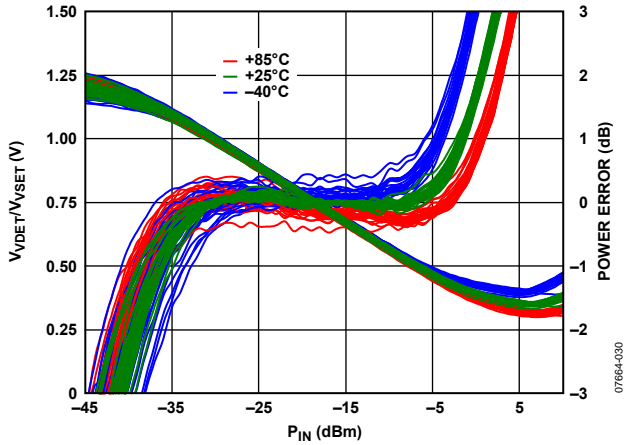

Figure 30. V_{VDET}/V_{VSET} Voltage and Log Conformance vs. Input Amplitude at 860 MHz, $R_{TADJ} = 22.1\text{ k}\Omega$

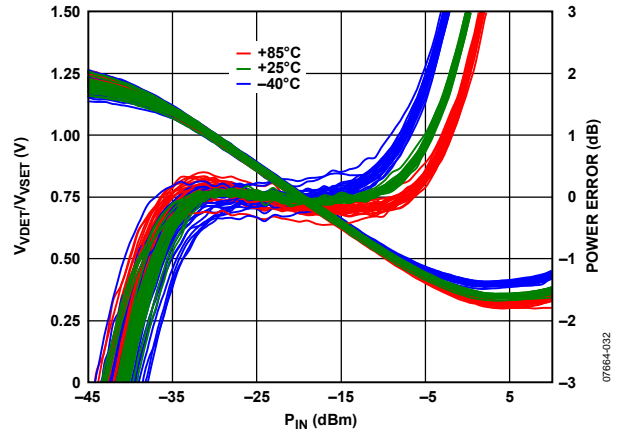

Figure 32. V_{VDET}/V_{VSET} Voltage and Log Conformance vs. Input Amplitude at 2150 MHz, $R_{TADJ} = 22.1\text{ k}\Omega$

CLOSED-LOOP AGC MODE

Unless otherwise noted, $V_S = 5\text{ V}$, $T_A = 25^\circ\text{C}$, $LO = -7\text{ dBm}$, I/Q inputs = 1.4 V p-p differential sine waves in quadrature on a 500 mV dc bias, baseband frequency = 1 MHz, LO source and RF output load impedances are 50 Ω . For AGC mode characterization setup, refer to Figure 42.

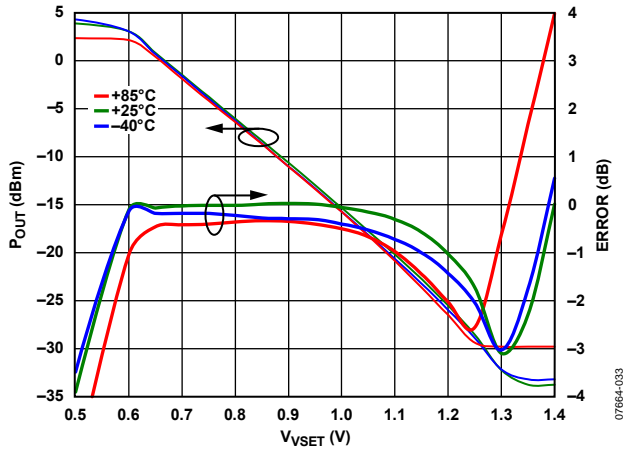

Figure 33. P_{OUT} and Error vs. V_{VSET} at 140 MHz

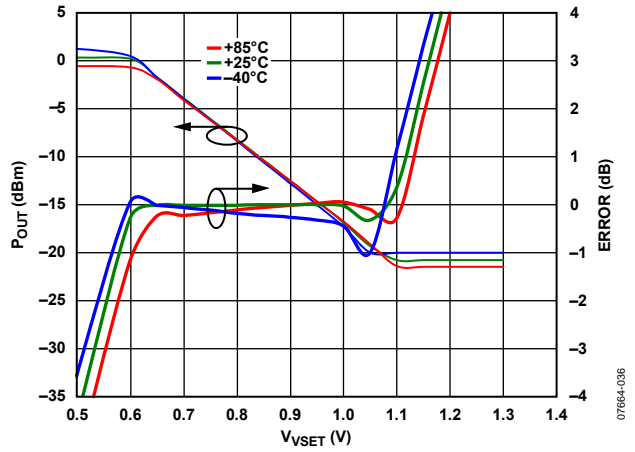

Figure 36. P_{OUT} and Error vs. V_{VSET} at 1450 MHz

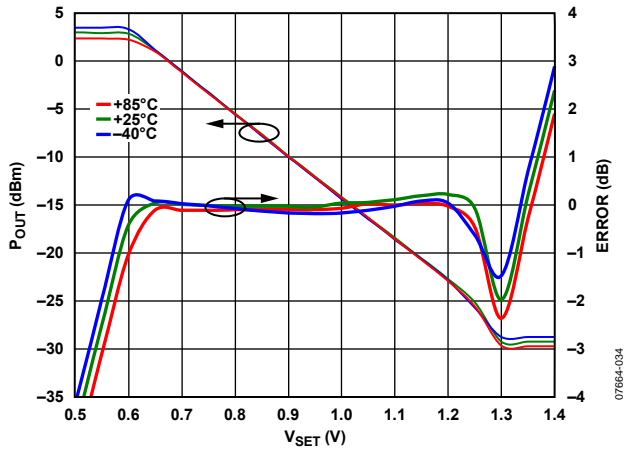

Figure 34. P_{OUT} and Error vs. V_{VSET} at 350 MHz

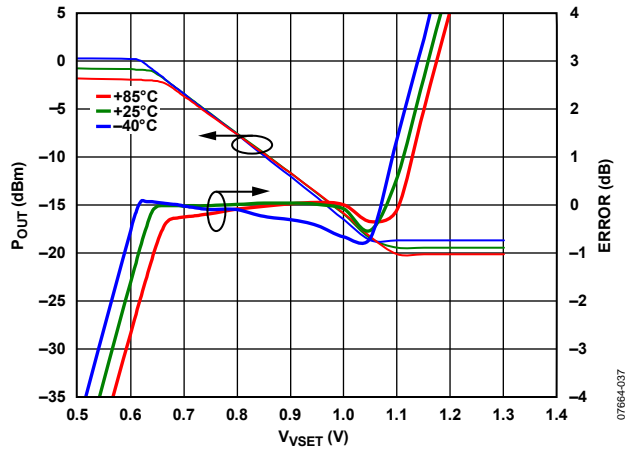

Figure 37. P_{OUT} and Error vs. V_{VSET} at 1900 MHz

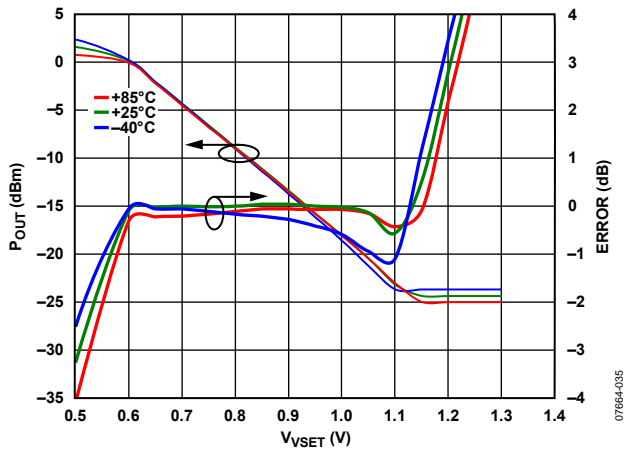

Figure 35. P_{OUT} and Error vs. V_{VSET} at 860 MHz

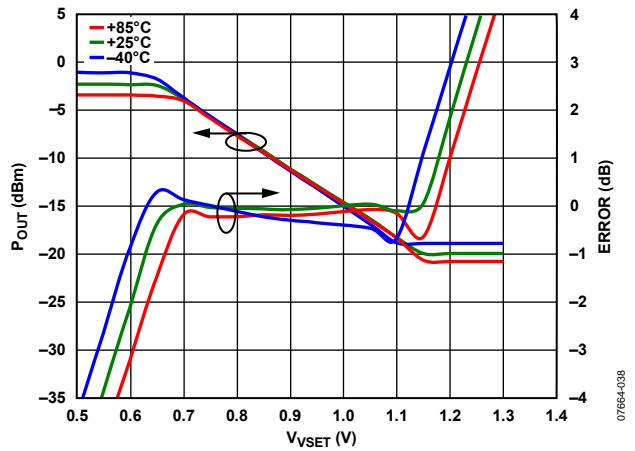

Figure 38. P_{OUT} and Error vs. V_{VSET} at 2150 MHz

CIRCUIT DESCRIPTION

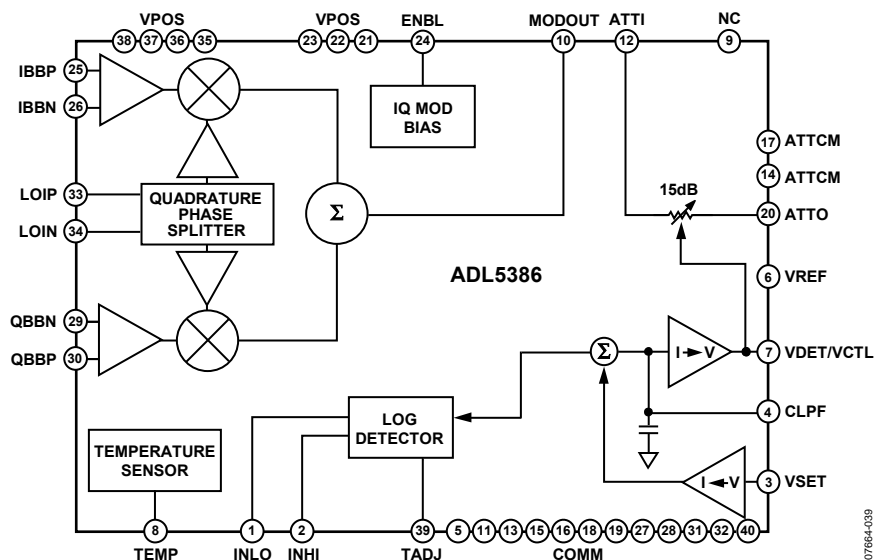

Figure 39. Block Diagram

OVERVIEW

The ADL5386 consists of three sections: a quadrature modulator, a logarithmic detector, and a voltage variable attenuator (VVA). The modulator section contains the circuitry for the following functions:

- Local oscillator (LO) interface
- Baseband voltage-to-current (V-to-I) converter
- Mixers
- Differential-to-single-ended (D-to-S) amplifier
- Temperature sensor and bias circuit

The detector section contains the logarithmic detector and amplifiers interfacing to the VSET input and VDET output. The variable attenuator section consists of a PI network of PHEMTs and resistors implemented on a GaAs die separate from the silicon die where the rest of the circuits reside. A detailed block diagram of the device is shown in Figure 39.

QUADRATURE MODULATOR SECTION

The LO interface generates two LO signals at 90° of phase difference to drive two mixers in quadrature. Baseband signals are converted into currents by the V-to-I converters that feed into the two mixers. The outputs of the mixers are combined in the differential-to-single-ended amplifier, which provides a $50\ \Omega$ output interface. Reference currents to each section are generated by the bias circuit. A detailed description of each section follows.

LO Interface

The LO interface consists of a buffer amplifier followed by a pair of frequency dividers that generate two carriers at half the input frequency and in quadrature with each other. Each carrier is then amplified and amplitude-limited to drive the double-balanced mixers.

V-to-I Converter

The differential baseband input voltages that are applied to the baseband input pins are fed to a pair of common-emitter, voltage-to-current converters. The output currents then modulate the two half-frequency LO carriers in the mixer stage.

Mixers

The ADL5386 has two double-balanced mixers: one for the in-phase channel (I channel) and one for the quadrature channel (Q channel). These mixers are based on the Gilbert cell design of four cross-connected transistors. The output currents from the two mixers are summed together in the resistor-inductor loads in the D-to-S amplifier.

D-to-S Amplifier

The output D-to-S amplifier consists of two emitter followers driving a totem-pole output stage. Output impedance is established by the emitter resistors in the output transistors. The output of this stage connects to the output (VOUT) pin.

Bias Circuits

A band gap based bias circuit provides proportional-to-absolute temperature as well as temperature stable reference currents for the different circuits in the modulator section. The ENBL input controls the operation of this bias circuit. When ENBL is pulled to a low level, the bias references are turned off, and the whole modulator section is turned off as a result. A voltage that is proportional to the absolute temperature of the circuit is also available at the TEMP pin.

A separator bias circuit provides the reference currents as well as the reference voltages for the detector and voltage variable attenuator sections. This bias circuit can also be disabled by pulling the TADJ pin high, which in turn shuts down the detector section.

LOGARITHMIC DETECTOR

The design of the log detector is similar to that of the [AD8317](#) standalone log detector device, where the log function is generated by a series of limiting amplifiers and detectors. The output current from this log detector is compared with that from a voltage-to-current converter connected to the VSET input. Any net difference between these two currents is pumped into an on-chip integrating capacitor that is generally augmented by additional off-chip capacitance. The voltage on the integrating capacitor is amplified and produces an output error voltage that is generally used to adjust the attenuation of the voltage variable attenuator until the VSET current and the current from the log detector are balanced.

VOLTAGE VARIABLE ATTENUATOR (VVA)

The VVA is implemented on a GaAs die separate from the silicon die where the modulator and detector reside. The VVA is formed by PHEMTs and resistors connected in a PI network to provide the attenuator function. The gate source bias on the PHEMTs are controlled by the voltages on the VREF and VDET/VCTL pins, resulting in different attenuation between ATTI and ATTO as the voltage at VDET/VCTL is varied. The resistance in the shunt paths between ATTI and ATTO to ATTCM vary in the opposite manner as the paths between ATTI and ATTO to maintain good return loss through different attenuation levels.

BASIC CONNECTIONS

OPEN-LOOP POWER CONTROL MODE

Figure 41 shows the basic connections for operating the ADL5386 when the voltage variable attenuator (VVA) is driven from an external voltage source and not from the built-in AGC circuit. In this mode, the inputs to the RF detector should be both ac-coupled to ground. The TADJ pin is tied to the supply, disabling the unused detector and reducing the current consumption by approximately 15 mA. The IQ modulator is enabled by pulling the ENBL pin high.

The output of the modulator is ac-coupled to the input of the VVA (Pin ATTI). The VVA is bidirectional; therefore, the modulator can also be configured to drive ATTO and to take the final output at ATTU.

The attenuation of the VVA is controlled by the voltages on Pin VREF and Pin VDET/VCTL. VREF should be tied to a low impedance external voltage of 2 V. This voltage can be conveniently derived from the supply voltage using a pair of resistors, but this voltage must then be buffered with an op amp to prevent bias current related voltage drops.

With VREF set to 2 V, a variable voltage between 0 V and 2 V on VDET/VCTL sets the attenuation. Maximum attenuation is achieved when $V_{DET}/V_{CTL} = 0$ V, and minimum attenuation is achieved when $V_{DET}/V_{CTL} = 2$ V.

Figure 40 shows a plot of P_{OUT} vs. the control voltage (applied to the VDET/VCTL pin) at 350 MHz when the modulator is driven by 1 V p-p sine and cosine signals on its baseband inputs and a $2 \times$ LO of 700 MHz.

In this mode, the detector cannot be used in any kind of standalone mode because its output pin (VDET/VCTL) is used as an input.

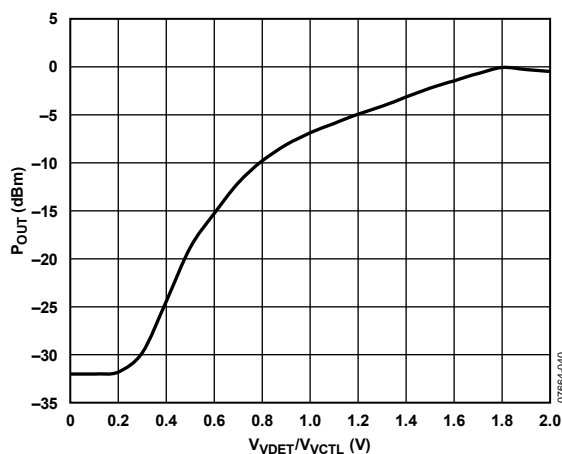

Figure 40. P_{OUT} vs. V_{DET}/V_{CTL} at 350 MHz for Open-Loop Power Control Mode

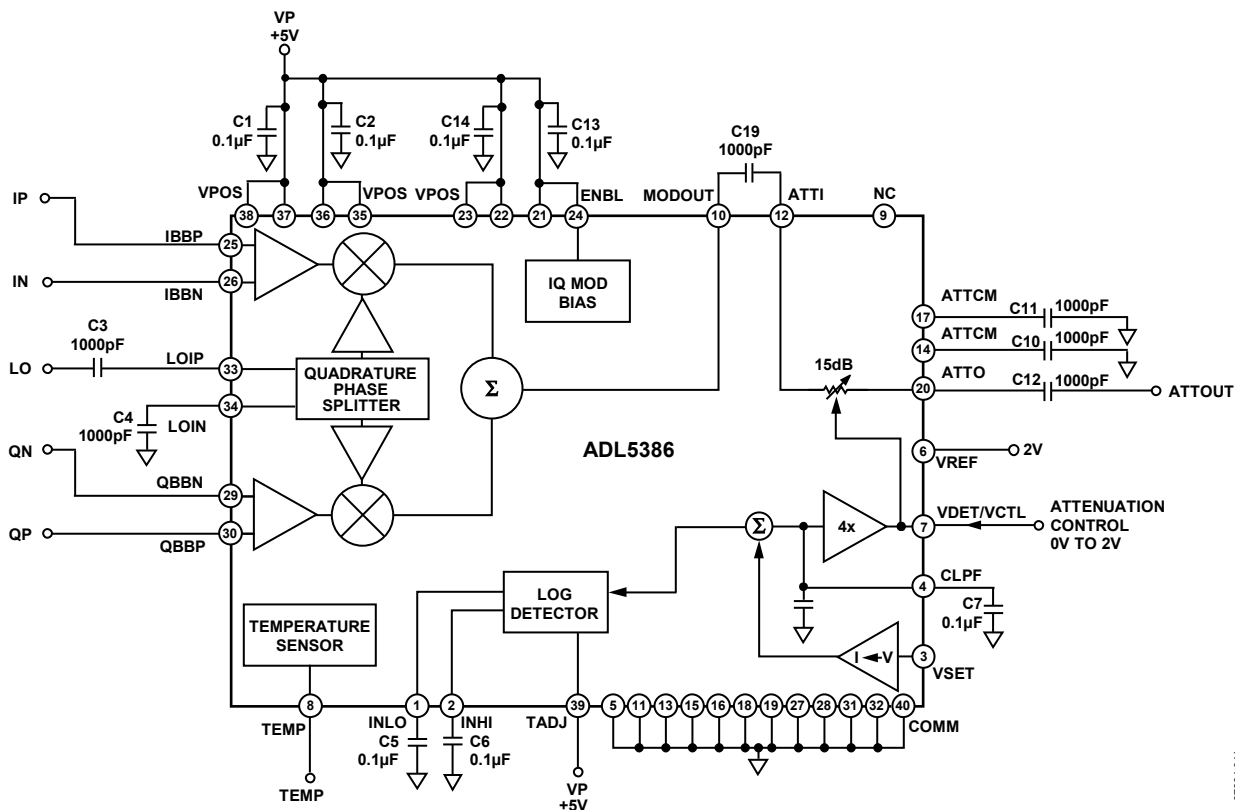

Figure 41. Basic Connections for Open-Loop Power Control Mode

POWER SUPPLY AND GROUNDING

The VPOS supply pins should be connected to a common 5 V supply. This supply can vary from 4.75 to 5.5 V. The power supply pins should be adequately decoupled using 0.1 μF capacitors located close to each pin. Adjacent pins can share decoupling capacitors, as shown in Figure 41.

The COMM ground pins should be connected to a common low impedance ground plane. The exposed paddle on the underside of the package is also soldered to a low thermal and electrical impedance ground plane. If the ground plane spans multiple layers on the circuit board, the layers should be stitched together with nine vias under the exposed paddle. The Analog Devices, AN-772 Application Note, *A Design and Manufacturing Guide for the Lead Frame Chip Scale Package (LFCSP)*, discusses the thermal and electrical grounding of the LFCSP in detail.

DEVICE ENABLE AND DISABLE

The IQ modulator section can be enabled or disabled by pulling the ENBL pin high or low, respectively. The detector section of the circuit can be disabled by pulling the TADJ pin high.

BASEBAND INPUTS

The baseband inputs, QBBP, QBBN, IBBP, and IBBN, must be driven from a differential source. The nominal drive level of 1.4 V p-p differential (700 mV p-p on each pin) is biased to a common-mode level of 500 mV dc. This drive level generates an output power level (at MODOUT) of between 2 dBm and 6 dBm based on output frequency.

The dc common-mode bias level for the baseband inputs can range from 400 mV to 600 mV. This results in a reduction in the usable input ac swing range. The nominal dc bias of 500 mV allows for the largest ac swing, limited on the bottom end by the ADL5386 input range and on the top end by the output compliance range on most Analog Devices DACs.

LO INPUT

A single-ended LO signal is applied to the LOIP pin through an ac coupling capacitor. A square wave or a sine wave can be used to drive the LO port. The recommended LO drive power is -7 dBm. An LO power level of -7 dBm is the minimum level that should be used for output frequencies below 140 MHz ($f_{LO} \leq 280$ MHz). At output frequencies above 140 MHz, the LO power can be reduced to -13 dBm. The LO return pin, LOIN, should be ac-coupled to ground through a low impedance path.

The nominal LO drive of -7 dBm can be increased to up to $+2$ dBm. The effect of LO power on sideband suppression and carrier feedthrough is shown in Figure 15 and Figure 16.

AGC MODE

The on-board log amp power detector of the ADL5386 can be used to implement an automatic output power control (commonly referred to as AGC) loop that effectively linearizes the transfer function of the VVA. To implement this mode, a number of circuit modifications are necessary.

A portion of the output signal of the VVA is coupled back to the input of the log amp detector. This can be done with a power splitter or with a directional coupler as shown in Figure 42. The coupling factor or power split ratio should be set so that the detector never sees a power level that is greater than about -10 dBm (the transfer function of the detector loses some linearity above this level). In the example shown in Figure 42, a maximum output power from the VVA/modulator of $+3$ dBm is desired. A directional coupler with a coupling factor of approximately $+15$ dB drops this level down to -12 dBm at the input of the detector.

The input signal to the detector produces a current that is drawn from the summing node (Pin CLPF) into the detector block. A setpoint voltage that is applied to the VSET pin is converted into a current that is pumped into the summing node. If these two currents are not equal, the net current flows into or out of the CLPF capacitor on Pin 4. This changes the voltage on the CLPF node that in turn changes the voltage on the VDET/VCTL pin. This pin is internally connected to the attenuation control pin of the VVA. Therefore, the attenuation control voltage on Pin 7 (VDET/VCTL) increases or decreases until the I_{SET} and I_{DET} currents match. When this equilibrium is reached, the voltage on CLPF (and thereby on the control voltage node of the VVA) is held steady.

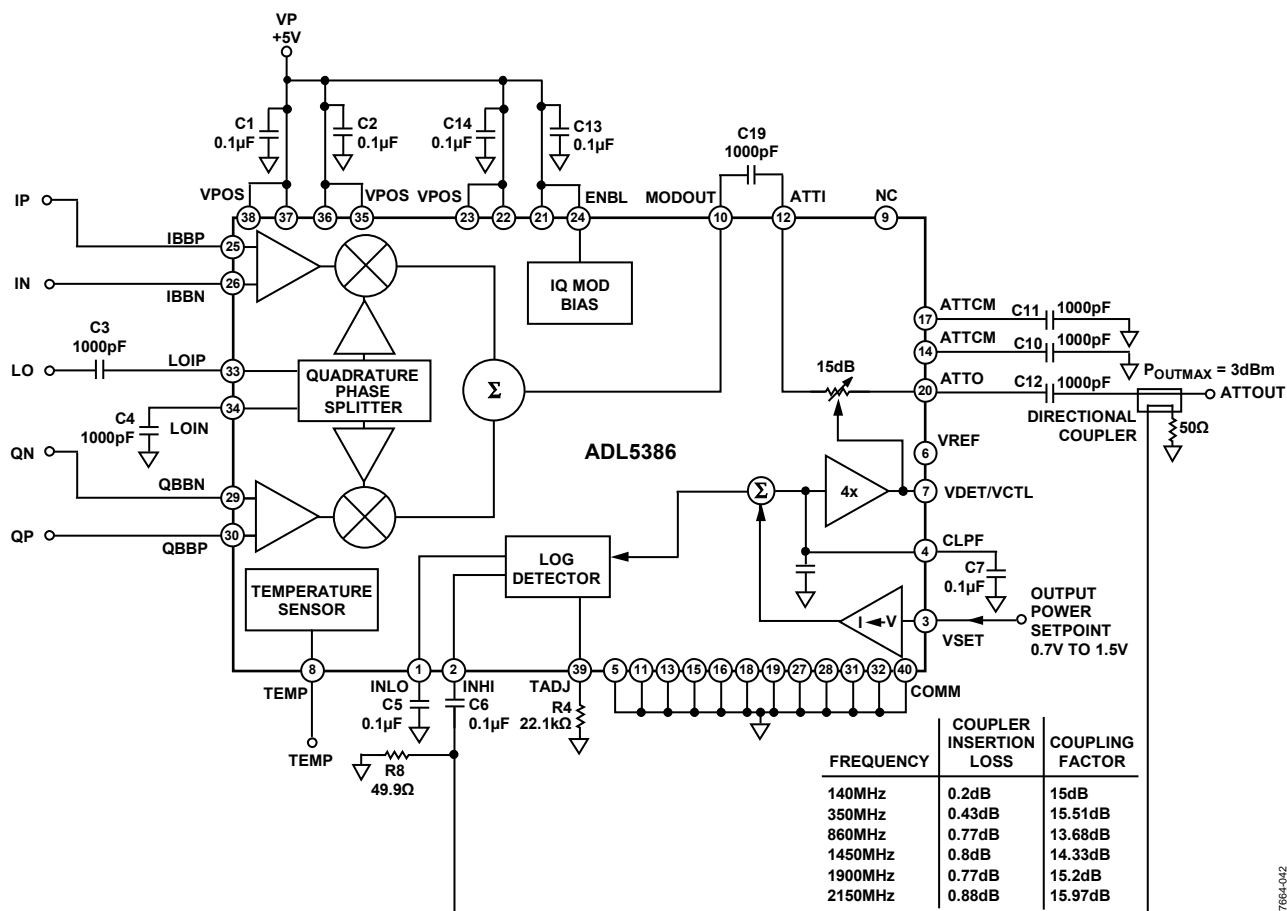

Figure 42. Basic Connections for AGC Mode

07864-042

Figure 43 shows the resulting transfer function of the AGC loop, that is, output power (on ATTO) vs. setpoint voltage (on VSET) at 350 MHz. Figure 43 shows a linear-in-dB relationship between P_{OUT} and V_{VSET} over at least 25 dB. It also includes a plot of the linearity of the transfer function in dB. The linearity is calculated by measuring the slope and intercept of the transfer function using the V_{VSET} and P_{OUT} data between V_{VSET} levels of 0.7 and 1 V. This yields an idealized transfer function of

$$P_{OUT_IDEAL} = SLOPE \times (V_{VSET} - INTERCEPT)$$

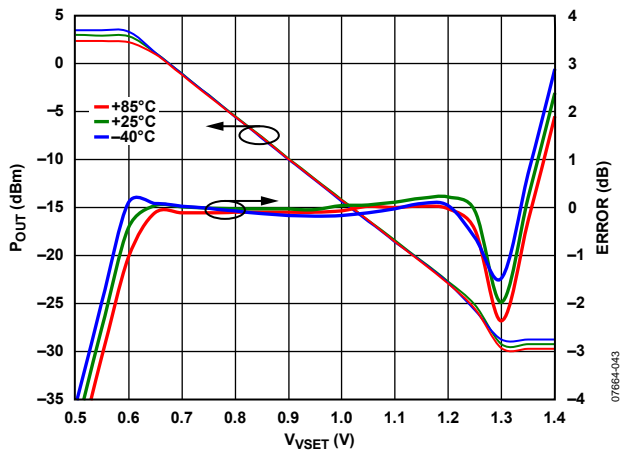

Figure 43. P_{OUT} vs. V_{VSET} Transfer Function in AGC Mode (1 V p-p Differential Baseband Input Voltage on I and Q)

The error in decibels is given by

$$ERROR (dB) = (P_{OUT} - P_{OUT_IDEAL})/SLOPE$$

The relationship between the input level of the detector and the voltage on V_{VSET} follows from the nominal transfer function of the detector when operating in measurement mode (V_{VSET} is connected directly to V_{DET}). Figure 44 shows the measurement mode relationship between the detector input level and the output voltage at 350 MHz. Figure 44 shows that an input level of -12 dBm produces an output of 0.6 V. In AGC mode, a setpoint voltage of 0.6 V causes the loop to adjust until the detector input level is -12 dBm. Remembering the coupling factor of the directional coupler, the -12 dBm level at the detector corresponds to a power level of approximately $+3$ dBm at the output of the VVA. Therefore, with a 15 dB coupling factor, a setpoint voltage of 0.6 produces an output power from the VVA of 3 dBm, as shown in Figure 43.

In general, the loop should be designed with a level of attenuation between ATTO and INHI (detector input) that results in the detector always seeing a power level that is within its linear operating range. Because the power detector has a linear input range that is larger than the attenuation range of the VVA this is generally achievable. In addition, it is desirable to map the desired VVA output power range into the detector's region of maximum linearity. In the example shown, where a maximum output power of $+3$ dBm is desired, the input range to the detector is -12 dBm to -44 dBm. Notice how the degraded linearity of the detector below -40 dBm (see Figure 44) can also be observed in the closed-loop transfer function at output power levels below -25 dBm (Figure 43).

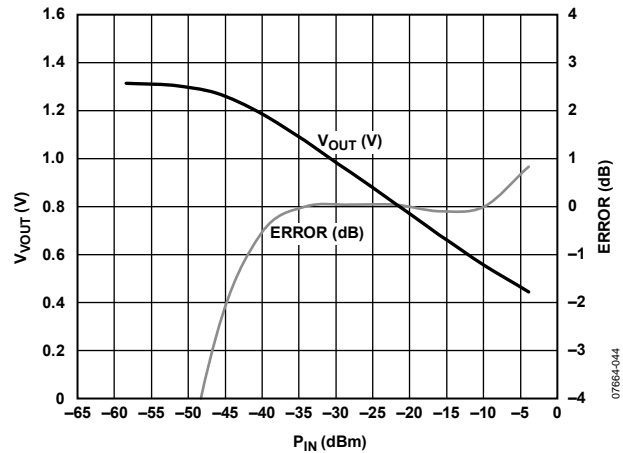

Figure 44. Measurement Mode Relationship Between V_{VOUT}/V_{VSET} and Detector Input Power at 350 MHz

SETTING THE TADJ RESISTOR

The primary component of the temperature variation of the V_{VOUT}/V_{VSET} voltage and the detector RF input is the drift of the intercept. This temperature drift can be compensated by connecting a resistor between TADJ (Pin 39) and ground. The optimum resistance value for the frequencies at which the ADL5386 is characterized has been experimentally determined to be 22.1 k Ω . Note that the accuracy specifications of the detector and performance plots assume that this resistance is in place.

USING THE DETECTOR IN STANDALONE MEASUREMENT MODE

The on-board log detector of the ADL5386 can be used in measurement mode, that is, where an RF signal is applied to the INHI pin of the detector, and an output voltage, proportional to the log of this input signal, is provided at the VDET output. In this mode, short VDET to VSET and ac couple the ATTI, ATTO, and ATTCM pins to ground. Note that the VVA cannot be used because the VVA control voltage shares a common pin with the output of the detector.

Table 5 summarizes the required configuration changes for the three operating modes discussed.

DAC MODULATOR INTERFACING

The ADL5386 is designed to interface with minimal components to members of the Analog Devices family of digital-to-analog converters (DACs). These DACs feature an output current swing from 0 mA to 20 mA, and the interface described in this section can be used with any DAC that has a similar output.

Table 5. Configuring Operating Modes

Mode	INHI	VSET	VDET/VCTL	VREF	ENBL	MODOUT	ATTI	ATTO
AGC	AC couple to ATTO via directional coupler	Externally apply 0.5 V to 1.4 V	Open	Open	High	AC couple to ATTI	AC couple to MODOUT	RF output
Open loop ¹	AC couple to GND	Open	Externally apply 0 V to 2 V	Externally apply 2 V	High	AC couple to ATTI	AC couple to MODOUT	RF output
Standalone detector	AC couple to MODOUT or other RF signal	Connect to VDET	Connect to VSET	Open	High	RF output, ac-coupled	AC couple to GND	AC couple to GND

¹ Tie TADJ to VPOS.

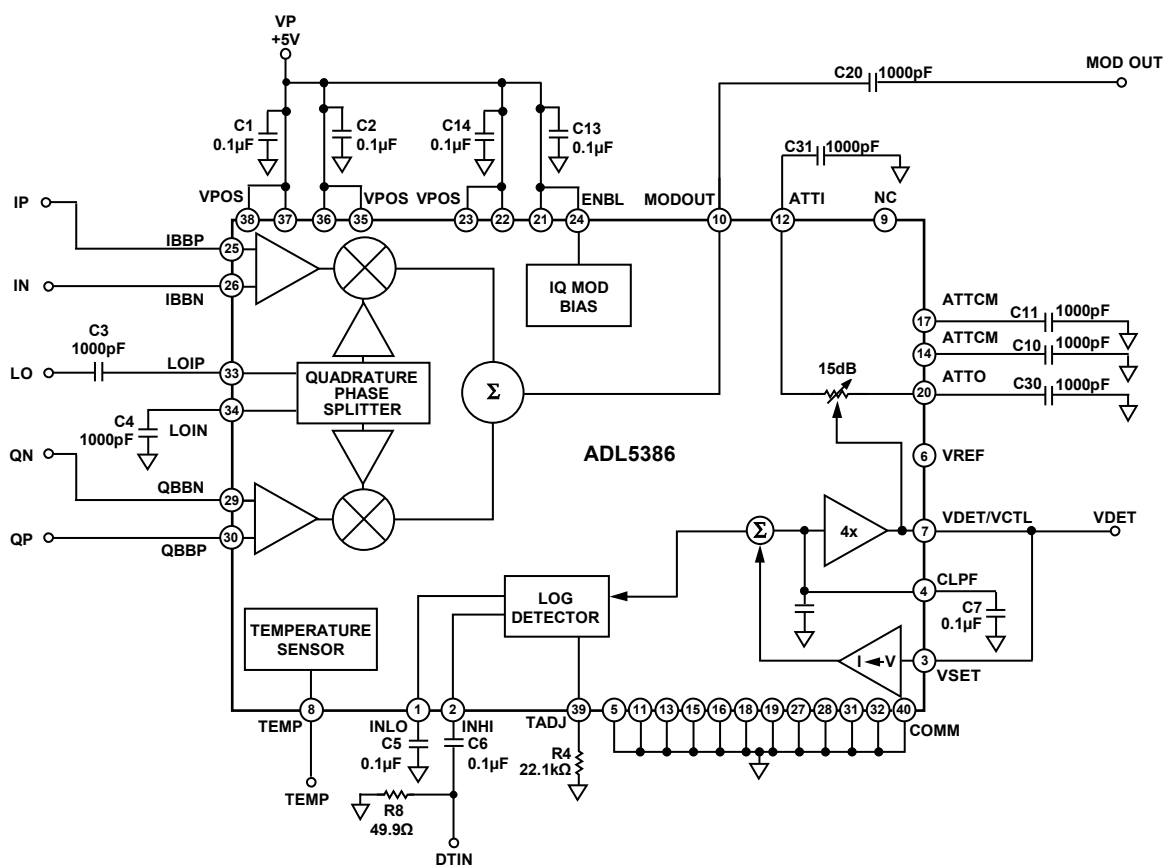

Figure 45. Connections for Operating the Detector in Standalone Mode

07864-045

ADL5386

Driving the ADL5386 with an Analog Devices TxDAC®

An example of the interface using the AD9788 TxDAC is shown in Figure 46. The baseband inputs of the ADL5386 require a dc bias of 500 mV. The average output current on each of the outputs of the AD9788 is 10 mA. Therefore, a single 50 Ω resistor to ground from each of the DAC outputs results in an average current of 10 mA flowing through each of the resistors, thus producing the desired 500 mV dc bias for the inputs to the ADL5386.

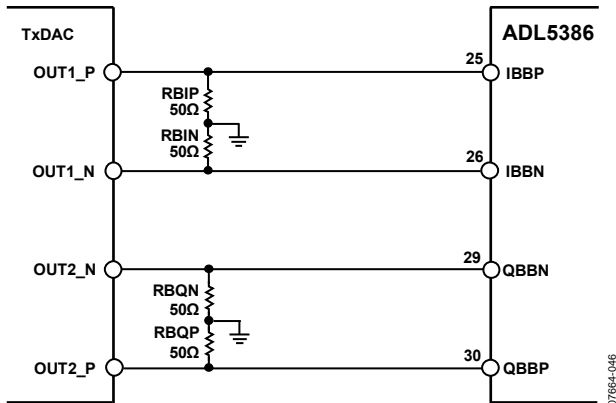

Figure 46. Interface Between AD9788 and ADL5386 with 50 Ω Resistors to Ground to Establish the 500 mV DC Bias for the ADL5386 Baseband Inputs

The AD9788 output currents source from 0 mA to 20 mA. With the 50 Ω resistors in place, the ac voltage swing going into the ADL5386 baseband inputs ranges from 0 V to 1 V. A full-scale sine wave out of the AD9788 can be described as a 1 V p-p single-ended (or 2 V p-p differential) sine wave with a 500 mV dc bias. The AD9788 also has the capability of easily compensating for gain, offset, and phase mismatch in the IQ signal path; therefore, optimizing performance of the ADL5386.

Limiting the AC Swing

There are situations in which it is desirable to reduce the ac voltage swing for a given DAC output current. To reduce the ac voltage swing, add an additional resistor to the interface. This resistor is placed in shunt between each side of the differential pair, as shown in Figure 47. It has the effect of reducing the ac swing without changing the dc bias already established by the 50 Ω resistors.

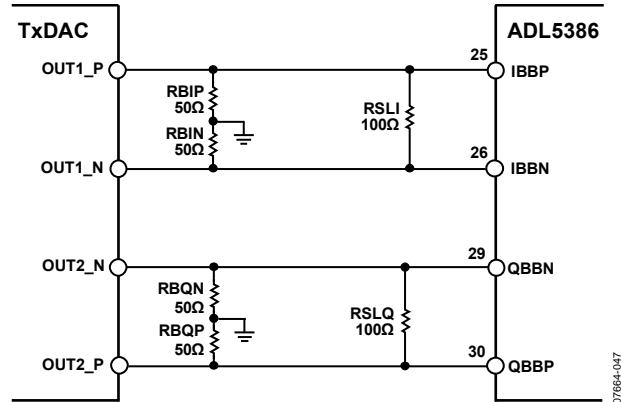

Figure 47. AC Voltage Swing Reduction Through Introduction of Shunt Resistor Between Differential Pair

The value of this ac voltage swing-limiting resistor is chosen based on the desired ac voltage swing. Figure 48 shows the relationship between the swing-limiting resistor and the peak-to-peak ac swing that it produces when 50 Ω bias-setting resistors are used.

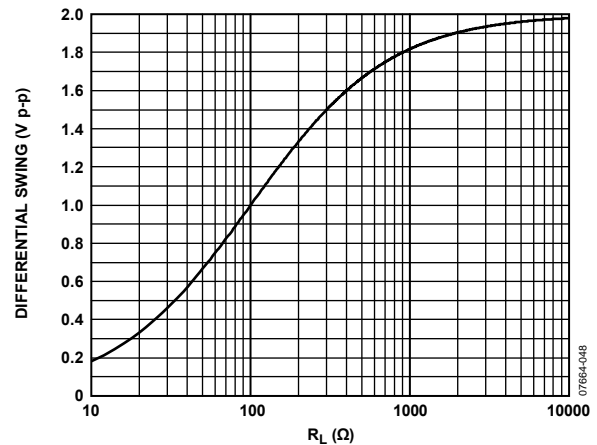

Figure 48. Relationship Between AC Swing-Limiting Resistor and Peak-to-Peak Voltage Swing with 50 Ω Bias-Setting Resistors

Filtering

When driving a modulator from a DAC, it is necessary to introduce a low-pass filter between the DAC and the modulator to reduce the DAC images. The interface for setting up the biasing and ac swing lends itself well to the introduction of such a filter. The filter can be inserted between the dc bias setting resistors and the ac swing-limiting resistor, thus establishing the input and output impedances for the filter. A filter example is shown in Figure 49.

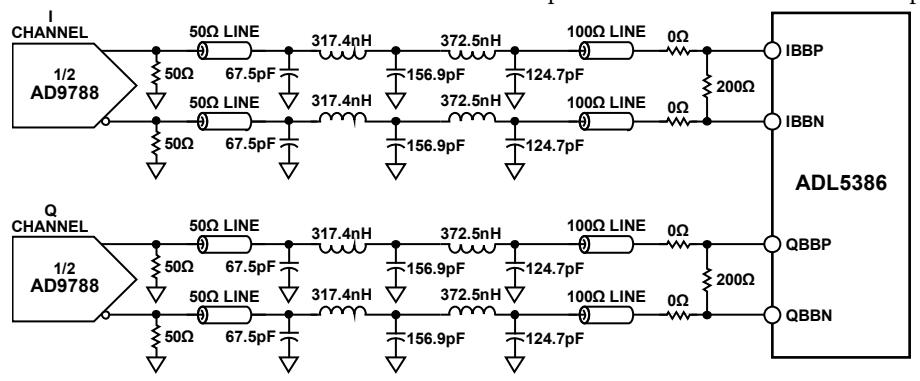

Figure 49. 39 MHz, 5-Pole Chebyshev Filter with In-Band Ripple of 0.1 dB for a 155 MSPS, 128 QAM Transmitter

SPECTRAL PRODUCTS FROM HARMONIC MIXING

For broadband applications, such as cable TV head-end modulators, special attention must be paid to harmonics of the LO. Figure 50 shows the level of these harmonics (out to 3 GHz) as a function of the output frequency from 125 MHz to 1000 MHz, in a single-sideband (SSB) test configuration, with a baseband signal of 1 MHz and a SSB level of approximately 0 dBm. To read this plot correctly, first pick the output frequency of interest on the trace called P_{OUT} . The associated harmonics can be read off the harmonic traces at multiples of this frequency. For example, at an output frequency of 500 MHz, the fundamental power is 0 dBm. The power of the second ($P_{2fc - BB}$) and third ($P_{3fc + BB}$) harmonics is -57 dBm (at 1000 MHz) and -11 dBm (at 1500 MHz), respectively. Of particular importance are the products from odd harmonics of the LO, generated from the switching operation in the mixers.

For cable TV operation at frequencies above approximately 500 MHz, these harmonics fall out of the band and can be filtered by a fixed filter. However, as the frequency drops below 500 MHz, these harmonics start to fall close to or inside the cable band. This calls for either limitation of the frequency range to above 500 MHz or the use of a switchable filter bank to block in-band harmonics at low frequencies.

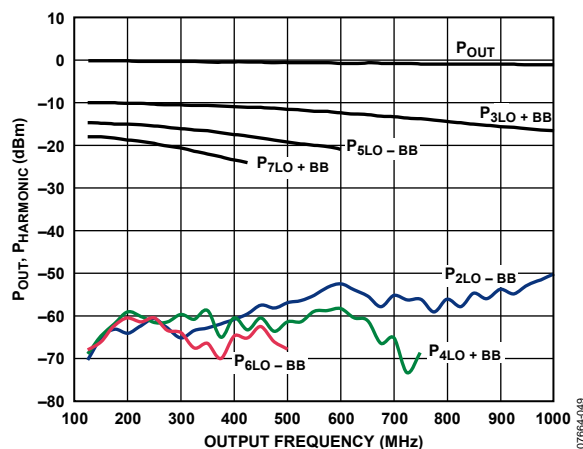

Figure 50. Spectral Components for Output Frequencies from 125 MHz to 1000 MHz

LO GENERATION USING PLLs

Analog Devices has a line of PLLs that can be used for generating the LO signal. Table 6 lists the PLLs together with their maximum frequency and phase noise performance.

Table 6. PLL Selection Table

Model	Frequency f_{IN} (MHz)	At 1 kHz Phase Noise dBc/Hz, 200 kHz PFD
ADF4002	400	-103 @ 400 MHz
ADF4106	6000	-93 @ 900 MHz
ADF4110	550	-91 @ 540 MHz
ADF4111	1200	-87 @ 900 MHz
ADF4112	3000	-90 @ 900 MHz
ADF4113	4000	-91 @ 900 MHz
ADF4116	550	-89 @ 540 MHz
ADF4117	1200	-87 @ 900 MHz
ADF4118	3000	-90 @ 900 MHz

The ADF4360-x comes as a family of chips, with nine operating frequency ranges. One can be chosen depending on the local oscillator frequency required. While the use of the integrated synthesizer may come at the expense of slightly degraded noise performance from the ADL5386, it can be a cheaper alternative to a separate PLL and VCO solution. Table 7 shows the options available. An up-to-date list of available PLLs can be found at www.analog.com/pll.

Table 7. ADF4360-x Family Operating Frequencies

Model	Output Frequency Range (MHz)
ADF4360-0	2400 to 2725
ADF4360-1	2050 to 2450
ADF4360-2	1850 to 2150
ADF4360-3	1600 to 1950
ADF4360-4	1450 to 1750
ADF4360-5	1200 to 1400
ADF4360-6	1050 to 1250
ADF4360-7	350 to 1800
ADF4360-8	65 to 400
ADF4360-9	1.1 to 200 (using auxiliary dividers)

ADL5386

TRANSMIT DAC OPTIONS

The AD9788 recommended in the previous sections is by no means the only DAC that can be interfaced with the ADL5386. There are other appropriate DACs depending on the level of performance required. Table 8 lists the dual TxDACs that Analog Devices offers for use in transmitter applications with the ADL5386.

Table 8. Dual TxDAC Selection Table

Part No.	Resolution (Bits)	Output Update Rate (MSPS)
AD9114/AD9115/AD9116/AD9117	8, 10, 12, 14	125
AD9741/AD9743/AD9745/AD9746/AD9747	8, 10, 12, 14, 16	250
AD9780/AD9781/AD9783	12, 14, 16	500
AD9776A/AD9778A/AD9779A	12, 14, 16	1000
AD9785/AD9787/AD9788	12, 14, 16	800

All DACs listed have nominal bias levels of 0.5 V and use the same DAC-modulator interface shown in Figure 46.

MODULATOR/DEMULATOR OPTIONS

Table 9 lists other Analog Devices modulators and demodulators.

Table 9. Modulator/Demodulator Options

Part No.	Modulator/Demodulator	Frequency Range (MHz)	Comments
AD8345	Modulator	140 to 1000	External quadrature
AD8346	Modulator	800 to 2500	
AD8349	Modulator	700 to 2700	
ADL5390	Modulator	20 to 2400	
ADL5370	Modulator	300 to 1000	
ADL5371	Modulator	500 to 1500	
ADL5372	Modulator	1500 to 2500	
ADL5373	Modulator	2300 to 3000	
ADL5374	Modulator	3000 to 4000	
ADL5375	Modulator	400 to 6000	
AD8347	Demodulator	800 to 2700	
AD8348	Demodulator	50 to 1000	
ADL5382	Demodulator	700 to 2700	
ADL5387	Demodulator	50 to 2000	
ADL5590	Modulator	869 to 960	
ADL5591	Modulator	1805 to 1990	
AD8340	Vector modulator	700 to 1000	
AD8341	Vector modulator	1500 to 2400	

EVALUATION BOARD

A populated, RoHS-compliant ADL5386 evaluation board is available. The ADL5386 has an exposed paddle underneath the package, which is soldered to the board.

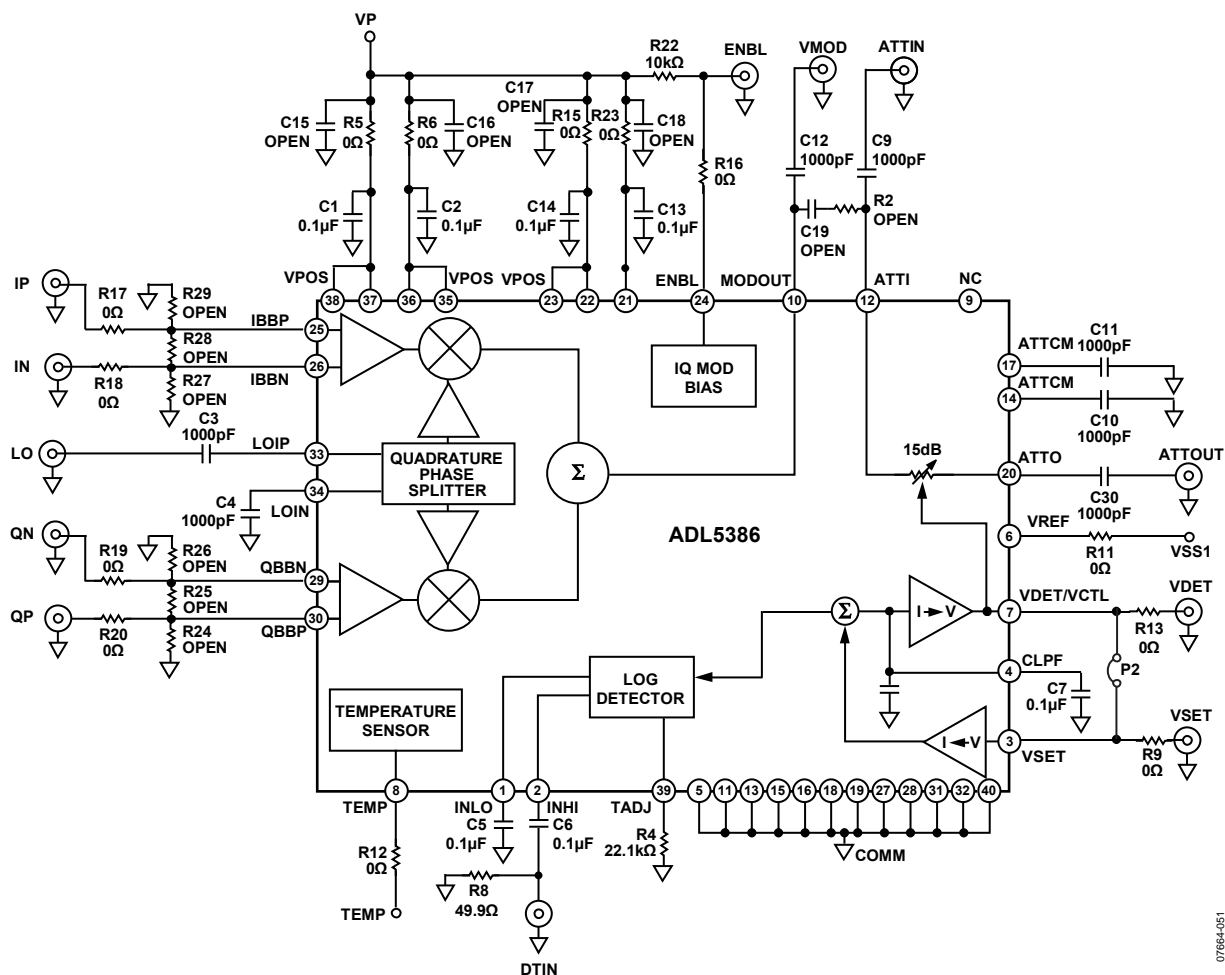

Figure 51. Evaluation Board Schematic

07664-051

Table 10. Evaluation Board Configuration Options

Component	Description	Default Condition
VP, GND	Power Supply and Ground Clip Leads.	VP = 5 V, GND = 0 V
R22	Device Enable. Apply either 5 V or 0 V to the SMA connector labeled ENBL to enable or disable the IQ modulator section of the circuit. If the ENBL SMA connector is left open, this node is pulled high by R22, enabling the IQ modulator.	R22 = 10 kΩ
R2, C9, C12, C19	Modulator VVA Interconnect. The output of the IQ modulator is available at the VMOD SMA connector. The input and output of the VVA can be accessed through the ATTN and ATTO SMA connectors. The IQ modulator output can be connected to the VVA by installing a 0 Ω resistor at R2 and a 1000 pF capacitor at C19. In this mode, C9 and C12 should be removed.	C9, C12 = 1000 pF (0402) R2, C19 = open (0402)
R17 to R20, R24 to R29	Baseband Input Filters. These component pads can be used to implement a low-pass filter for the baseband input signals.	R17 to R20 = 0 Ω (0402) R24 to R29 = open (0402)

ADL5386

Component	Description	Default Condition
P2	<p>Detector Controller Mode vs. Measurement Mode. When P2 is installed, the detector operates in standalone measurement mode, measuring the signal strength on the DTIN SMA connector and providing an output voltage on the VDET and VSET SMA connectors. To operate the device in AGC mode, P2 should be removed, a sample of the output of the VVA is connected to DTIN (using a directional coupler or a power splitter), and a setpoint voltage should be applied to the VSET SMA connector. To operate the VVA in open-loop mode, disable the detector by connecting TADJ to VP. DTIN should be ac-coupled to ground, and P2 should be removed. The VVA control voltage (0 V to 2 V) is applied to VDET, which becomes an input. The VSS1 terminal must be connected to a fixed 2 V source.</p>	P2 = installed

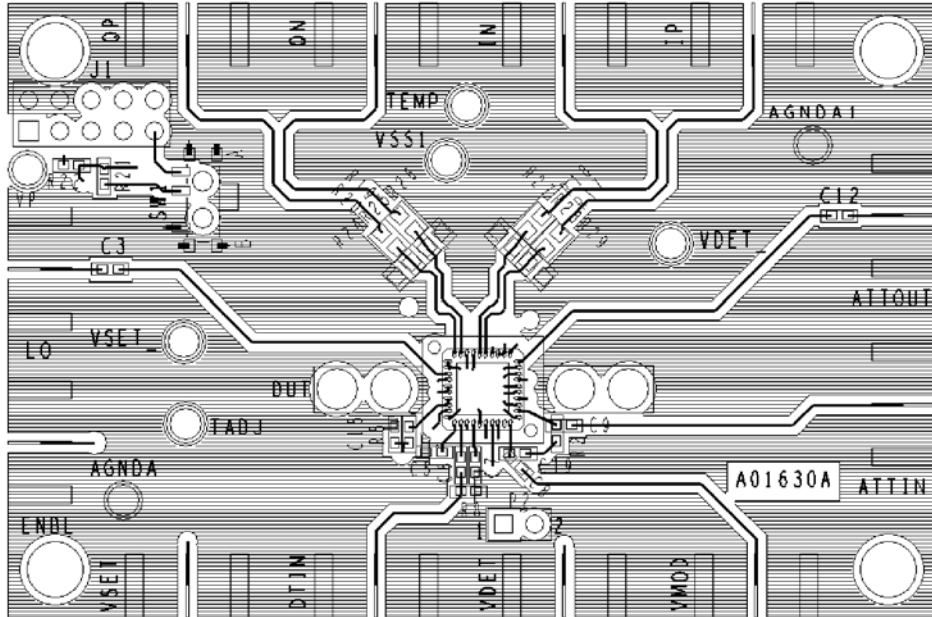

Figure 52. Layout of the Evaluation Board, Top Layer

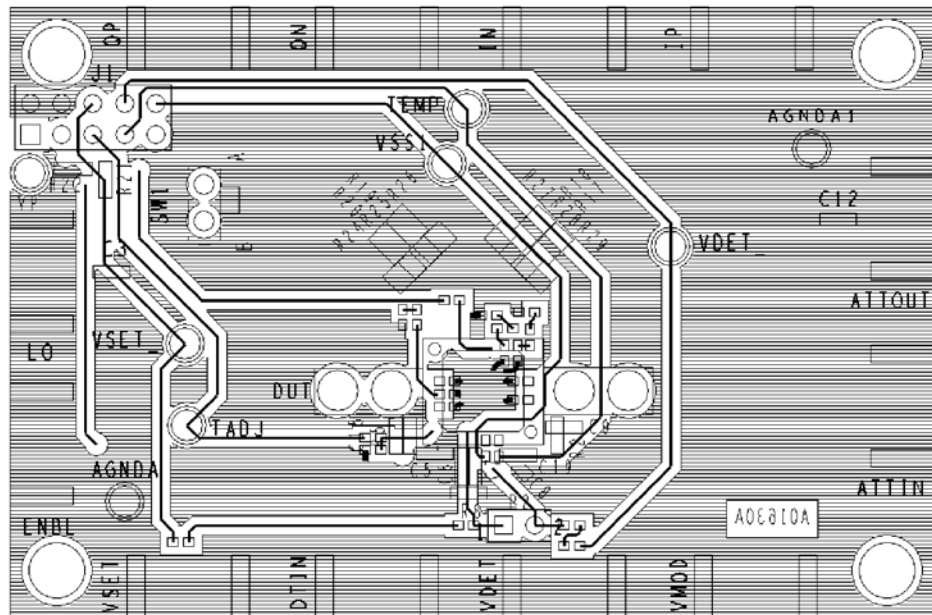

Figure 53. Layout of the Evaluation Board, Bottom Layer

CHARACTERIZATION SETUP

SSB SETUP

Figure 54 is a diagram of the characterization test stand setup for the ADL5386, which can test the product as a single sideband modulator. The Aeroflex IFR 3416 signal generator provides the I and Q inputs as well as the LO input. Output signals are measured directly using the spectrum analyzer, and currents and voltages are measured using the Agilent 34401A multimeter.

DETECTOR SETUP

Figure 55 is a diagram of the characterization test stand setup for the ADL5386, which can test the product as a log detector. The HP 8648D signal generator provides the input signal of the detector. All currents and voltages are measured using the Agilent 34401A multimeter.

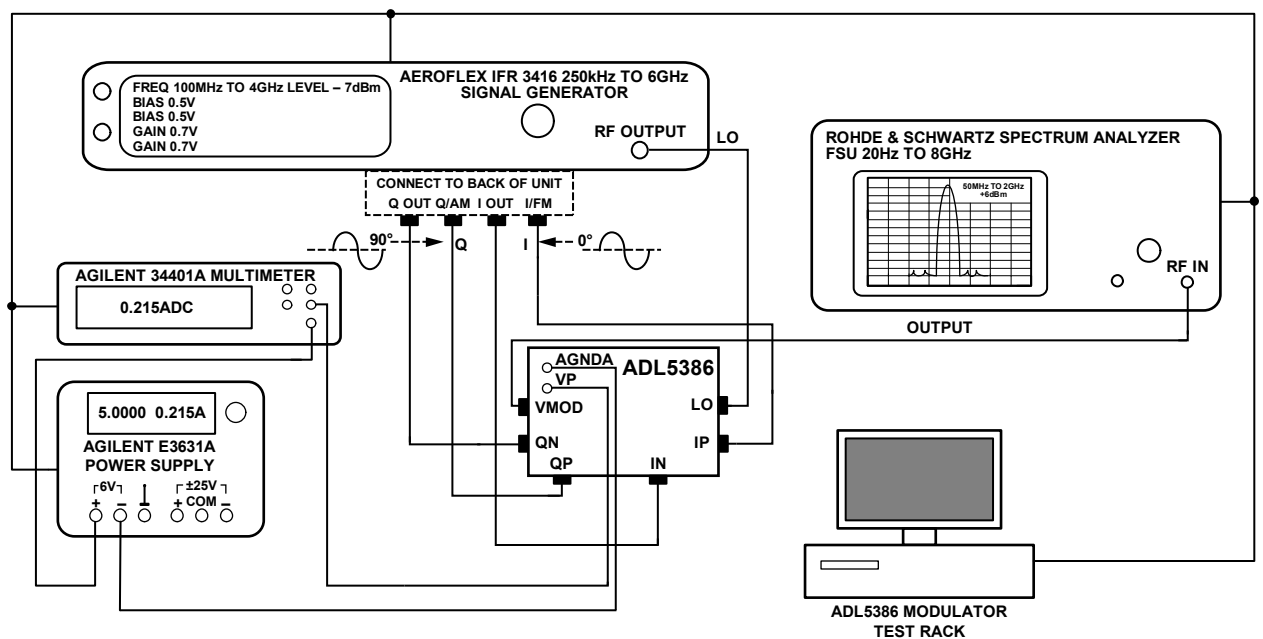

Figure 54. ADL5386 Characterization Board SSB Test Setup

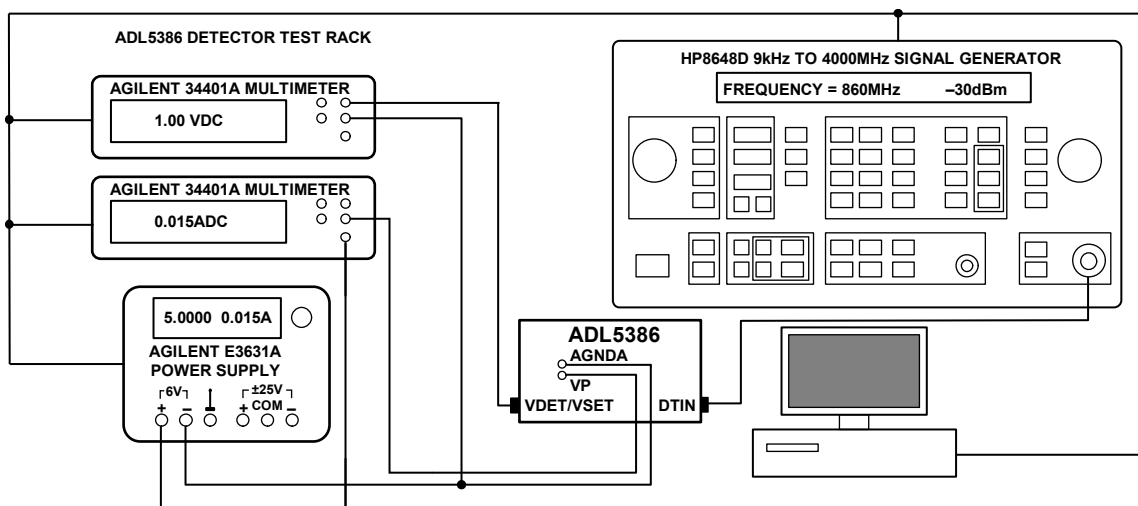

Figure 55. ADL5386 Characterization Board Detector Test Setup

ADL5386

VVA S-PARAMETERS SETUP

Figure 56 is a diagram of the characterization test stand setup for the ADL5386, which can test the product as a VVA. The HP 8753D network analyzer measures the s-parameters, while the Data Precision 8200 sweeps the VCTL voltage. Currents and voltages are measured using the Agilent 34401A multimeter.

VVA INTERMODULATION TEST SETUP

Figure 57 is a diagram of the characterization test stand setup for the ADL5386, which can test the product as a VVA. The IFR 2026B provides the two-tone signal to the VVA input, the Data Precision 8200 sweeps the VCTL voltage, while the spectrum analyzer measures the output tones of the VVA output. Currents and voltages are measured using the Agilent 34401A multimeter.

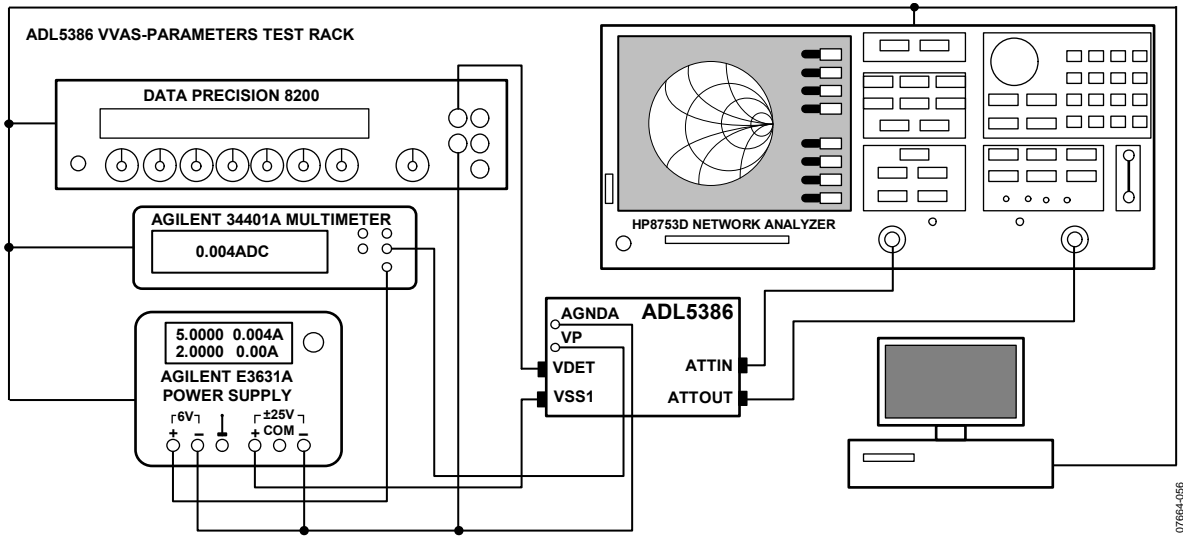

Figure 56. ADL5386 Characterization Board VVA S-Parameters Test Setup

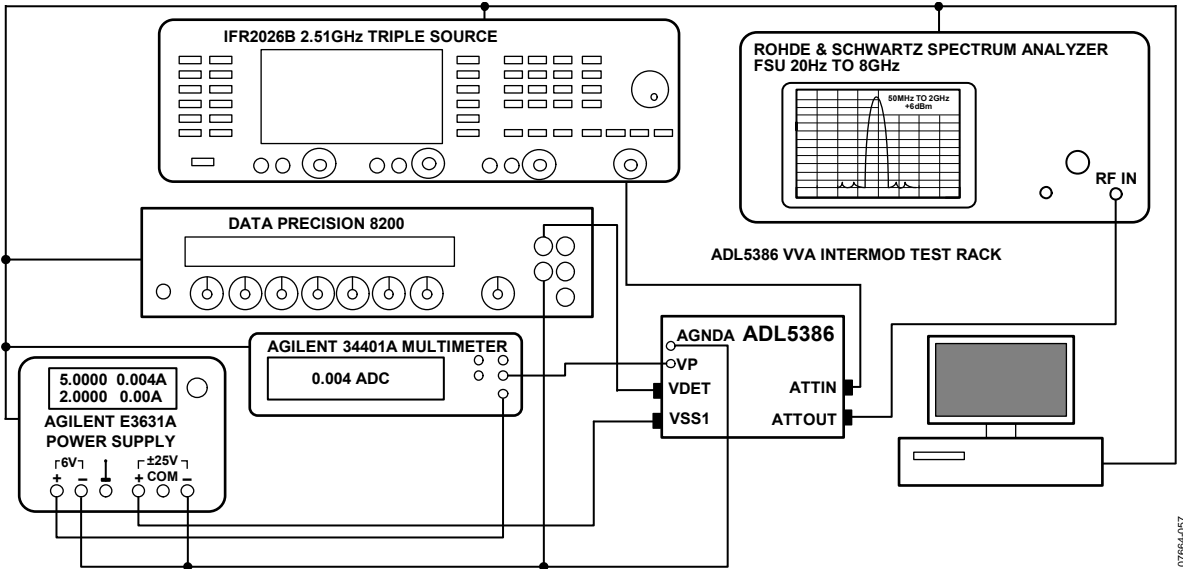
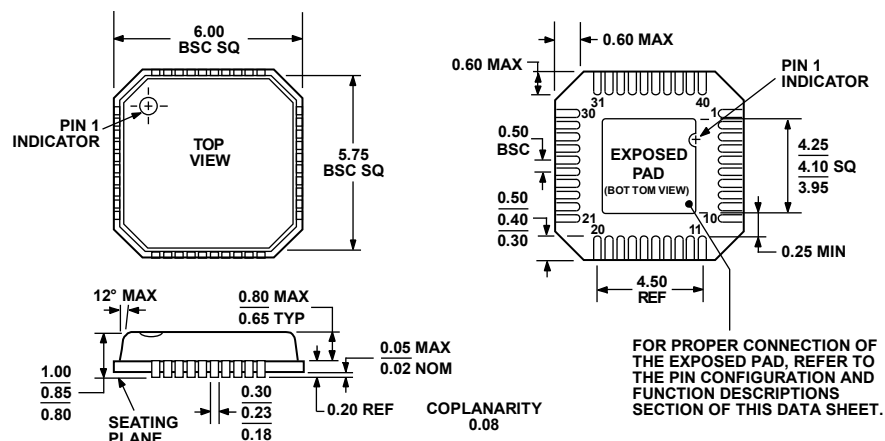

Figure 57. ADL5386 Characterization Board VVA Intermodulation Test Setup

OUTLINE DIMENSIONS



COMPLIANT TO JEDEC STANDARDS MO-220-VJJD-2

Figure 58. 40-Lead Lead Frame Chip Scale Package [LFCSP_VQ]
 6 mm × 6 mm Body, Very Thin Quad
 (CP-40-1)
 Dimensions shown in millimeters

072108-A

ORDERING GUIDE

Model	Temperature Range	Package Description	Package Option	Ordering Quantity
ADL5386ACPZ-R2 ¹	-40°C to +85°C	40-Lead LFCSP_VQ, 7" Tape and Reel	CP-40-1	250
ADL5386ACPZ-R7 ¹	-40°C to +85°C	40-Lead LFCSP_VQ, 7" Tape and Reel	CP-40-1	750
ADL5386-EVALZ ¹		Evaluation Board		1

¹ Z = RoHS Compliant Part.

ADL5386

NOTES

NOTES

ADL5386

NOTES

X-ON Electronics

Largest Supplier of Electrical and Electronic Components

Click to view similar products for [Modulator/Demodulator](#) category:

Click to view products by [Analog Devices](#) manufacturer:

Other Similar products are found below :

[LC72722PM-TLM-E](#) [HMC495LP3TR](#) [LT5571EUF#PBF](#) [LT5528EUF#PBF](#) [LT5502EGN#PBF](#) [THAT1510S08-U](#) [CMX909BD5](#)
[CMX589AD5](#) [ADRF6755ACPZ-R7](#) [ADRF6821ACPZ](#) [AD630ADZ](#) [AD630ARZ](#) [AD630JNZ](#) [AD630KNZ](#) [AD8346ARUZ-REEL7](#)
[AD8339ACPZ](#) [AD8345ARE](#) [AD8345AREZ](#) [AD8345AREZ-RL7](#) [AD8347ARUZ](#) [AD8347ARUZ-REEL7](#) [AD8348ARUZ](#) [AD8348ARUZ-](#)
[REEL7](#) [AD8349AREZ](#) [AD8349AREZ-RL7](#) [ADL5371ACPZ-R7](#) [ADL5387ACPZ-WP](#) [ADL5387ACPZ-R7](#) [ADL5372ACPZ-R7](#)
[ADL5373ACPZ-R7](#) [ADA2200ARUZ-REEL7](#) [AD8346ARUZ](#) [ADL5380-EVALZ](#) [ADL5382ACPZ-R7](#) [ADL5385ACPZ-R7](#) [AD630ARZ-RL](#)
[ADL5375-15ACPZ-R7](#) [ADL5380ACPZ-R7](#) [ADL5375-05ACPZ-R7](#) [AD8333ACPZ-WP](#) [AD8341ACPZ-REEL7](#) [ADRF6703ACPZ-R7](#)
[ADRF6750ACPZ-R7](#) [ADRF6806ACPZ-R7](#) [HMC630LP3ETR](#) [HMC500LP3ETR](#) [HMC495LP3ETR](#) [HMC500LP3E](#) [HMC630LP3E](#)
[HMC631LP3E](#)