

### FEATURES

- Triple supervisory circuits
- Supply voltage range of 2.0 V to 5.5 V
- Pretrimmed threshold options: 1.8 V, 2.5 V, 3.3 V, and 5 V
- Adjustable 0.6 V and 1.25 V voltage references
- Maximum supply current of 40  $\mu$ A
- 140 ms (minimum) reset timeout
- RESET valid from  $V_{DD} \geq 1.1$  V
- Push-pull RESET and  $\overline{\text{RESET}}$  outputs
- 8-lead, narrow body SOIC package
- Temperature range:  $-40^{\circ}\text{C}$  to  $+85^{\circ}\text{C}$

### APPLICATIONS

- Supervising DSPs/microcontrollers
- Industrial and portable equipment
- Wireless systems
- Notebook/desktop computers

### GENERAL DESCRIPTION

The ADM13307 is a triple voltage supervisor designed to monitor up to three voltage levels in DSP and microprocessor-based systems.

There are five models available, all of which feature a combination of internally pretrimmed undervoltage threshold options for monitoring 1.8 V, 2.5 V, 3.3 V, and 5 V supplies. There are also two adjustable input options with undervoltage thresholds of either 0.6 V or 1.25 V.

The ADM13307-18, ADM13307-25, and ADM13307-33 models have two internally fixed thresholds and one externally programmable threshold via a resistor string. The ADM13307-4 and ADM13307-5 offer one internally fixed threshold and two externally programmable thresholds. See the Ordering Guide for a list of all available options.

During power-up,  $\overline{\text{RESET}}$  is asserted when the supply voltage exceeds 1.1 V. The device then monitors the  $\text{SENSE}_{EV}$  input pins and holds the  $\overline{\text{RESET}}$  output low as long as the  $\text{SENSE}_{EV}$  pins remain below the rising threshold voltage,  $V_{IT+}$ .

Once the supplies monitored at the  $\text{SENSE}_{EV}$  inputs rise above their associated thresholds, the reset signal remains low for the reset timeout period before deasserting. Subsequently, if a voltage monitored by the  $\text{SENSE}_{EV}$  pins falls below its associated falling input threshold voltage,  $V_{IT-}$ , the  $\overline{\text{RESET}}$  output asserts.

### FUNCTIONAL BLOCK DIAGRAMS

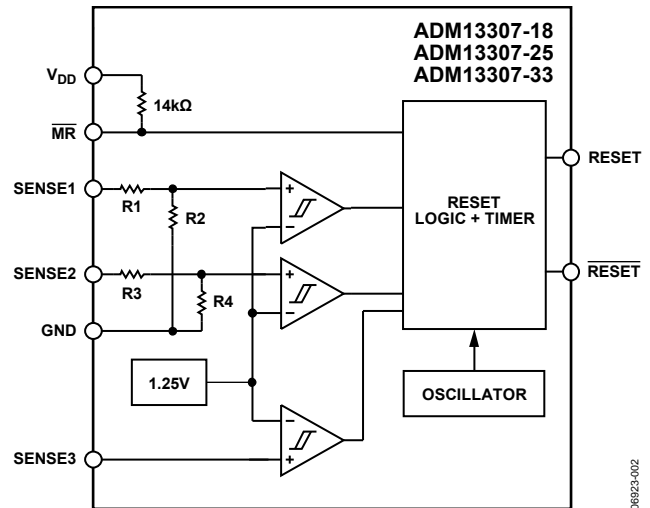

Figure 1.

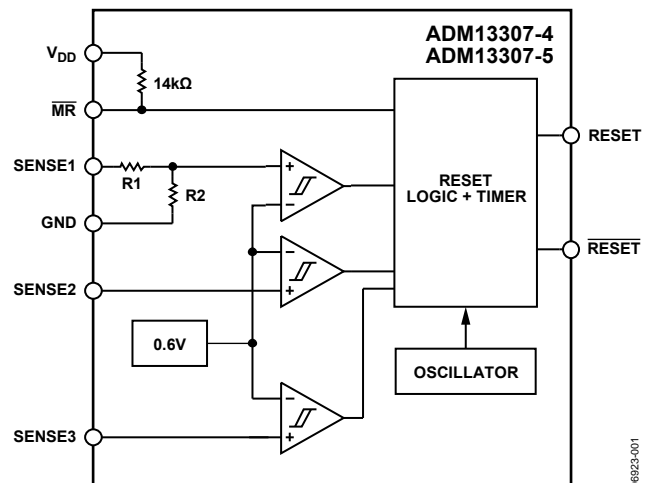

Figure 2.

The ADM13307 features both an active high RESET and an active low  $\overline{\text{RESET}}$  output.

The manual reset input of the ADM13307 can be used to initiate a reset by means of an external push button or logic signal.

The ADM13307 is available in an 8-lead narrow body SOIC package. The device operates over the extended industrial temperature range of  $-40^{\circ}\text{C}$  to  $+85^{\circ}\text{C}$ .

#### Rev. 0

Information furnished by Analog Devices is believed to be accurate and reliable. However, no responsibility is assumed by Analog Devices for its use, nor for any infringements of patents or other rights of third parties that may result from its use. Specifications subject to change without notice. No license is granted by implication or otherwise under any patent or patent rights of Analog Devices. Trademarks and registered trademarks are the property of their respective owners.

## TABLE OF CONTENTS

Features .....	1	Thermal Resistance .....	6
Applications.....	1	ESD Caution.....	6
General Description .....	1	Pin Configuration and Function Descriptions.....	7
Functional Block Diagrams.....	1	Typical Performance Characteristics .....	8
Revision History .....	2	Theory of Operation .....	10
Specifications.....	3	Input Configuration.....	10
Timing Requirements .....	5	Reset Output .....	10
Switching Characteristics .....	5	Manual Reset ( $\overline{\text{MR}}$ ).....	10
Functional Truth Table .....	5	Outline Dimensions .....	11
Absolute Maximum Ratings.....	6	Ordering Guide .....	11

## REVISION HISTORY

8/07—Revision 0: Initial Version

## SPECIFICATIONS

$V_{DD} = 2.0\text{ V to }5.5\text{ V}$ ,  $-40^{\circ}\text{C} \leq T_A \leq +85^{\circ}\text{C}$ , unless otherwise noted.

**Table 1. ADM13307-18, ADM13307-25, and ADM13307-33**

Parameter	Min	Typ	Max	Unit	Test Conditions/Comments
OPERATING VOLTAGE RANGE, $V_{DD}$	2.0		5.5	V	
SUPPLY CURRENT, $I_{DD}$			40	$\mu\text{A}$	
INPUT CAPACITANCE, $C_I$		10		pF	$V_I = 0\text{ V to }V_{DD}$
RESET, $\overline{\text{RESET}}$ Output					
High Level Output Voltage, $V_{OH}$	$V_{DD} - 0.2$			V	$I_{OH} = -20\ \mu\text{A}$
	$V_{DD} - 0.4$			V	$I_{OH} = -2\ \text{mA}$ , $V_{DD} = 3.3\ \text{V}$
	$V_{DD} - 0.4$			V	$I_{OH} = -3\ \text{mA}$ , $V_{DD} = 5.5\ \text{V}$
Low Level Output Voltage, $V_{OL}$			0.2	V	$I_{OL} = 20\ \mu\text{A}$
			0.4	V	$I_{OL} = 2\ \text{mA}$ , $V_{DD} = 3.3\ \text{V}$
			0.4	V	$I_{OL} = 3\ \text{mA}$ , $V_{DD} = 5.5\ \text{V}$
Power-Up Reset Voltage <sup>1</sup>			0.4	V	$I_{OL} = 20\ \mu\text{A}$ , $V_{DD} \geq 1.1\ \text{V}$
SENSE INPUTS					
Falling Input Threshold Voltage, $V_{IT-}$	1.22	1.25	1.28	V	$T_A = 0^{\circ}\text{C to }85^{\circ}\text{C}$
	1.64	1.68	1.72	V	$T_A = 0^{\circ}\text{C to }85^{\circ}\text{C}$
	2.20	2.25	2.30	V	$T_A = 0^{\circ}\text{C to }85^{\circ}\text{C}$
	2.86	2.93	3.00	V	$T_A = 0^{\circ}\text{C to }85^{\circ}\text{C}$
	4.46	4.55	4.64	V	$T_A = 0^{\circ}\text{C to }85^{\circ}\text{C}$
	1.22	1.25	1.29	V	$T_A = -40^{\circ}\text{C to }+85^{\circ}\text{C}$
	1.64	1.68	1.73	V	$T_A = -40^{\circ}\text{C to }+85^{\circ}\text{C}$
	2.20	2.25	2.32	V	$T_A = -40^{\circ}\text{C to }+85^{\circ}\text{C}$
	2.86	2.93	3.02	V	$T_A = -40^{\circ}\text{C to }+85^{\circ}\text{C}$
	4.46	4.55	4.67	V	$T_A = -40^{\circ}\text{C to }+85^{\circ}\text{C}$
Hysteresis at SENSEv Inputs, $V_{HYS}$		10		mV	$V_{IT-} = 1.25\ \text{V}$
		15		mV	$V_{IT-} = 1.68\ \text{V}$
		20		mV	$V_{IT-} = 2.25\ \text{V}$
		30		mV	$V_{IT-} = 2.93\ \text{V}$
		40		mV	$V_{IT-} = 4.55\ \text{V}$
INPUT VOLTAGE AT MR					
High Level, $V_{IH}$	$0.7 \times V_{DD}$			V	
Low Level, $V_{IL}$			$0.3 \times V_{DD}$	V	
INPUT TRANSITION RISE AND FALL RATE AT $\overline{\text{MR}}$			50	ns/V	
HIGH LEVEL INPUT CURRENT, $I_H$					
$\overline{\text{MR}}$		-130	-180	$\mu\text{A}$	$\overline{\text{MR}} = 0.7 \times V_{DD}$ , $V_{DD} = 5.5\ \text{V}$
SENSE1		5	8	$\mu\text{A}$	SENSE1 = $V_{DD} = 5.5\ \text{V}$
SENSE2		6	9	$\mu\text{A}$	SENSE2 = $V_{DD} = 5.5\ \text{V}$
SENSE3	-25		+25	nA	SENSE3 = $V_{DD}$
LOW LEVEL INPUT CURRENT, $I_L$					
$\overline{\text{MR}}$		-430	-600	$\mu\text{A}$	$\overline{\text{MR}} = 0\ \text{V}$ , $V_{DD} = 5.5\ \text{V}$
SENSEv	-25		+25	nA	SENSE1, SENSE2, SENSE3 = 0 V

<sup>1</sup> The lowest supply voltage at which  $\overline{\text{RESET}}$  becomes active.  $t_r, V_{DD} \geq 15\ \mu\text{s/V}$ .

# ADM13307

$V_{DD} = 2.0 \text{ V to } 5.5 \text{ V}$ ,  $-40^\circ\text{C} \leq T_A \leq +85^\circ\text{C}$ , unless otherwise noted.

**Table 2. ADM13307-4 and ADM13307-5**

Parameter	Min	Typ	Max	Unit	Test Conditions/Comments
OPERATING VOLTAGE RANGE, $V_{DD}$	2.0		5.5	V	
SUPPLY CURRENT, $I_{DD}$			40	$\mu\text{A}$	
INPUT CAPACITANCE, $C_i$		10		pF	$V_i = 0 \text{ V to } V_{DD}$
RESET, $\overline{\text{RESET}}$ Output					
High Level Output Voltage, $V_{OH}$	$V_{DD} - 0.2$			V	$I_{OH} = -20 \mu\text{A}$
	$V_{DD} - 0.4$			V	$I_{OH} = -2 \text{ mA}$ , $V_{DD} = 3.3 \text{ V}$
	$V_{DD} - 0.4$			V	$I_{OH} = -3 \text{ mA}$ , $V_{DD} = 5.5 \text{ V}$
Low Level Output Voltage, $V_{OL}$			0.2	V	$I_{OL} = 20 \mu\text{A}$
			0.4	V	$I_{OL} = 2 \text{ mA}$ , $V_{DD} = 3.3 \text{ V}$
			0.4	V	$I_{OL} = 3 \text{ mA}$ , $V_{DD} = 5.5 \text{ V}$
Power-Up Reset Voltage <sup>1</sup>			0.4	V	$I_{OL} = 20 \mu\text{A}$ , $V_{DD} \geq 1.1 \text{ V}$
SENSE INPUTS					
Falling Input Threshold Voltage, $V_{IT-}$	0.5946	0.6	0.6048	V	$T_A = -40^\circ\text{C to } +85^\circ\text{C}$
	0.5952	0.6	0.6048	V	$T_A = -40^\circ\text{C to } +85^\circ\text{C}$ , $2.35 \text{ V} \leq V_{DD} \leq 5.5 \text{ V}$
	2.23	2.25	2.29	V	$T_A = -40^\circ\text{C to } +85^\circ\text{C}$
	2.90	2.93	2.98	V	$T_A = -40^\circ\text{C to } +85^\circ\text{C}$
Hysteresis at SENSEv Inputs, $V_{HYS}$		0		mV	$V_{IT-} = 0.6 \text{ V}$
		20		mV	$V_{IT-} = 2.25 \text{ V}$
		30		mV	$V_{IT-} = 2.93 \text{ V}$
INPUT VOLTAGE AT $\overline{\text{MR}}$					
High Level, $V_{IH}$	$0.7 \times V_{DD}$			V	
Low Level, $V_{IL}$			$0.3 \times V_{DD}$	V	
INPUT TRANSITION RISE AND FALL RATE AT $\overline{\text{MR}}$			50	ns/V	
HIGH LEVEL INPUT CURRENT, $I_{IH}$					
$\overline{\text{MR}}$		-130	-180	$\mu\text{A}$	$\overline{\text{MR}} = 0.7 \times V_{DD}$ , $V_{DD} = 5.5 \text{ V}$
SENSE1		5	8	$\mu\text{A}$	SENSE1 = $V_{DD} = 5.5 \text{ V}$
SENSE2	-50		+50	nA	SENSE2 = $V_{DD} = 5.5 \text{ V}$
SENSE3	-25		+25	nA	SENSE3 = $V_{DD}$
LOW LEVEL INPUT CURRENT, $I_L$					
$\overline{\text{MR}}$		-430	-600	$\mu\text{A}$	$\overline{\text{MR}} = 0 \text{ V}$ , $V_{DD} = 5.5 \text{ V}$
SENSEv	-25		+25	nA	SENSE1, SENSE2, SENSE3 = 0 V

<sup>1</sup> The lowest supply voltage at which  $\overline{\text{RESET}}$  becomes active.  $t_r$ ,  $V_{DD} \geq 15 \mu\text{s/V}$ .

**TIMING REQUIREMENTS**

$V_{DD} = 2.0\text{ V to }5.5\text{ V}$ ,  $R_L = 1\text{ M}\Omega$ ,  $C_L = 50\text{ pF}$ ,  $T_A = 25^\circ\text{C}$ .

**Table 3. ADM13307-18, ADM13307-25 and ADM13307-33**

Parameter	Min	Typ	Max	Unit	Test Conditions/Comments
Pulse Width ( $t_w$ )					
SENSEv	6			$\mu\text{s}$	$V_{\text{SENSEvL}} = V_{\text{IT-}} - 0.3\text{ V}$ , $V_{\text{SENSEvH}} = V_{\text{IT+}} + 0.3\text{ V}$
MR	100			ns	$V_{\text{IH}} = 0.7 \times V_{\text{DD}}$ , $V_{\text{IL}} = 0.3 \times V_{\text{DD}}$

**Table 4. ADM13307-4 and ADM13307-5**

Parameter	Min	Typ	Max	Unit	Test Conditions/Comments
Pulse Width ( $t_w$ )					
SENSEv		30		$\mu\text{s}$	$V_{\text{SENSEvL}} = V_{\text{IT-}} - 0.3\text{ V}$ , $V_{\text{SENSEvH}} = V_{\text{IT+}} + 0.3\text{ V}$
MR	100			ns	$V_{\text{IH}} = 0.7 \times V_{\text{DD}}$ , $V_{\text{IL}} = 0.3 \times V_{\text{DD}}$

**SWITCHING CHARACTERISTICS**

$V_{DD} = 2.0\text{ V to }5.5\text{ V}$ ,  $R_L = 1\text{ M}\Omega$ ,  $C_L = 50\text{ pF}$ ,  $T_A = 25^\circ\text{C}$

**Table 5. ADM13307-18, ADM13307-25 and ADM13307-33**

Parameter	Min	Typ	Max	Unit	Test Conditions/Comments
Delay Time ( $t_d$ )	140	200	280	ms	$V_{\text{I(SENSEv)}} \geq V_{\text{IT+}} + 0.2\text{ V}$ , $\overline{\text{MR}} \geq 0.7 \times V_{\text{DD}}$
Propagation Delay, High-to-Low, $\overline{\text{MR}}$ to RESET <sup>1</sup> /RESET <sup>1</sup> ( $t_{\text{PHL}}$ )		200	500	ns	$V_{\text{I(SENSEv)}} \geq V_{\text{IT+}} + 0.2\text{ V}$ , $V_{\text{IH}} \geq 0.7 \times V_{\text{DD}}$ , $V_{\text{IL}} \geq 0.3 \times V_{\text{DD}}$
Propagation Delay, Low-to-High, $\overline{\text{MR}}$ to RESET/RESET <sup>1</sup> ( $t_{\text{PLH}}$ )		200	500	ns	$V_{\text{I(SENSEv)}} \geq V_{\text{IT+}} + 0.2\text{ V}$ , $V_{\text{IH}} \geq 0.7 \times V_{\text{DD}}$ , $V_{\text{IL}} \geq 0.3 \times V_{\text{DD}}$
Propagation Delay, High-to-Low, SENSEv to RESET <sup>1</sup> /RESET <sup>1</sup> ( $t_{\text{PHL}}$ )		1	5	$\mu\text{s}$	$V_{\text{IH}} = V_{\text{IT+}} + 0.3\text{ V}$ , $V_{\text{IL}} = V_{\text{IT-}} - 0.3\text{ V}$ , $\overline{\text{MR}} \geq 0.7 \times V_{\text{DD}}$
Propagation Delay, Low-to-High, SENSEv to RESET/RESET <sup>1</sup> ( $t_{\text{PLH}}$ )		1	5	$\mu\text{s}$	$V_{\text{IH}} = V_{\text{IT+}} + 0.3\text{ V}$ , $V_{\text{IL}} = V_{\text{IT-}} - 0.3\text{ V}$ , $\overline{\text{MR}} \geq 0.7 \times V_{\text{DD}}$

<sup>1</sup> The reset timeout delay of 200 ms masks the propagation delay

**Table 6. ADM13307-4 and ADM13307-5**

Parameter	Min	Typ	Max	Unit	Test Conditions/Comments
Delay Time ( $t_d$ )	140	200	280	ms	$V_{\text{I(SENSEv)}} \geq V_{\text{IT+}} + 0.2\text{ V}$ , $\overline{\text{MR}} \geq 0.7 \times V_{\text{DD}}$
Propagation Delay, High-to-Low, $\overline{\text{MR}}$ to RESET <sup>1</sup> /RESET <sup>1</sup> ( $t_{\text{PHL}}$ )		200	500	ns	$V_{\text{I(SENSEv)}} \geq V_{\text{IT+}} + 0.2\text{ V}$ , $V_{\text{IH}} \geq 0.7 \times V_{\text{DD}}$ , $V_{\text{IL}} \geq 0.3 \times V_{\text{DD}}$
Propagation Delay, Low-to-High, $\overline{\text{MR}}$ to RESET/RESET <sup>1</sup> ( $t_{\text{PLH}}$ )		200	500	ns	$V_{\text{I(SENSEv)}} \geq V_{\text{IT+}} + 0.2\text{ V}$ , $V_{\text{IH}} \geq 0.7 \times V_{\text{DD}}$ , $V_{\text{IL}} \geq 0.3 \times V_{\text{DD}}$
Propagation Delay, High-to-Low, SENSEv to RESET <sup>1</sup> /RESET <sup>1</sup> ( $t_{\text{PHL}}$ )		30		$\mu\text{s}$	$V_{\text{IH}} = V_{\text{IT+}} + 0.3\text{ V}$ , $V_{\text{IL}} = V_{\text{IT-}} - 0.3\text{ V}$ , $\overline{\text{MR}} \geq 0.7 \times V_{\text{DD}}$
Propagation Delay, Low-to-High, SENSEv to RESET/RESET <sup>1</sup> ( $t_{\text{PLH}}$ )		30		$\mu\text{s}$	$V_{\text{IH}} = V_{\text{IT+}} + 0.3\text{ V}$ , $V_{\text{IL}} = V_{\text{IT-}} - 0.3\text{ V}$ , $\overline{\text{MR}} \geq 0.7 \times V_{\text{DD}}$

<sup>1</sup> The reset timeout delay of 200 ms masks the propagation delay.

**FUNCTIONAL TRUTH TABLE****Table 7.**

MR	SENSE1 > V <sub>IT1</sub>	SENSE2 > V <sub>IT2</sub>	SENSE3 > V <sub>IT3</sub>	RESET	RESET
L	X <sup>1</sup>	X <sup>1</sup>	X <sup>1</sup>	L	H
H	0	0	0	L	H
H	0	0	1	L	H
H	0	1	0	L	H
H	0	1	1	L	H
H	1	0	0	L	H
H	1	0	1	L	H
H	1	1	0	L	H
H	1	1	1	H	L

<sup>1</sup> X = don't care.

## ABSOLUTE MAXIMUM RATINGS

Table 8.

Parameter	Rating
Supply Voltage Range, $V_{DD}$	-0.3 V to +6 V
$\overline{MR}$	-0.3 V to $V_{DD} + 0.3$ V
SENSE1, SENSE2, SENSE3	$(V_{DD} + 0.3$ V) $V_{IT}/V_{REF}$
RESET, $\overline{RESET}$	-0.3 V to +6 V
Maximum Low Output Current	5 mA
Maximum High Output Current	-5 mA
Input Clamp Current ( $V_i < 0$ V, $V_i > V_{DD}$ )	$\pm 20$ mA
Output Clamp Current ( $V_o < 0$ V, $V_o > V_{DD}$ )	$\pm 20$ mA
Operating Temperature Range	-40°C to +85°C
Storage Temperature Range	-65°C to +150°C
Lead Temperature	
Soldering (10 sec)	300°C
Vapor Phase (60 sec)	215°C
Infrared (15 sec)	220°C

Stresses above those listed under Absolute Maximum Ratings may cause permanent damage to the device. This is a stress rating only; functional operation of the device at these or any other conditions above those indicated in the operational section of this specification is not implied. Exposure to absolute maximum rating conditions for extended periods may affect device reliability.

### THERMAL RESISTANCE

Table 9.

Package Type	$\theta_{JA}$	Unit
8-Lead SOIC_N (R-8)	206	°C/W

### ESD CAUTION



**ESD (electrostatic discharge) sensitive device.** Charged devices and circuit boards can discharge without detection. Although this product features patented or proprietary protection circuitry, damage may occur on devices subjected to high energy ESD. Therefore, proper ESD precautions should be taken to avoid performance degradation or loss of functionality.

## PIN CONFIGURATION AND FUNCTION DESCRIPTIONS

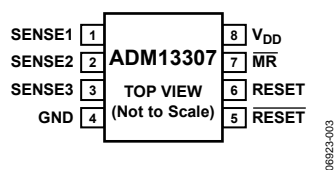

Figure 3. Pin Configuration

Table 10. Pin Function Descriptions

Pin No.	Mnemonic	Description
1	SENSE1	Sense Voltage Input 1.
2	SENSE2	Sense Voltage Input 2.
3	SENSE3	Sense Voltage Input 3.
4	GND	Ground.
5	RESET	Active Low Reset Output.
6	RESET	Active High Reset Output.
7	MR	Manual Reset.
8	V <sub>DD</sub>	Supply Voltage.

## TYPICAL PERFORMANCE CHARACTERISTICS

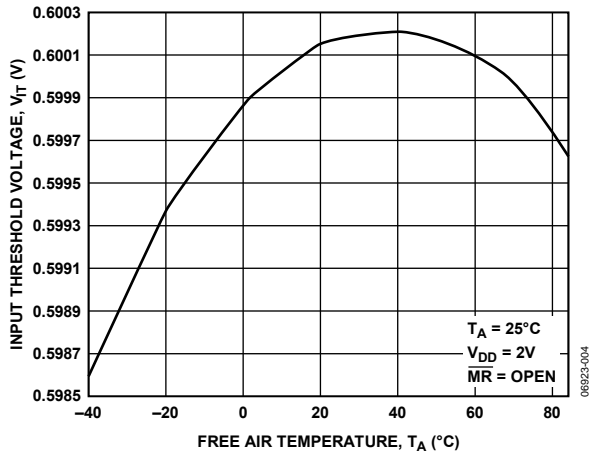

Figure 4. Sense Threshold Voltage vs. Free Air Temperature at  $V_{DD}$

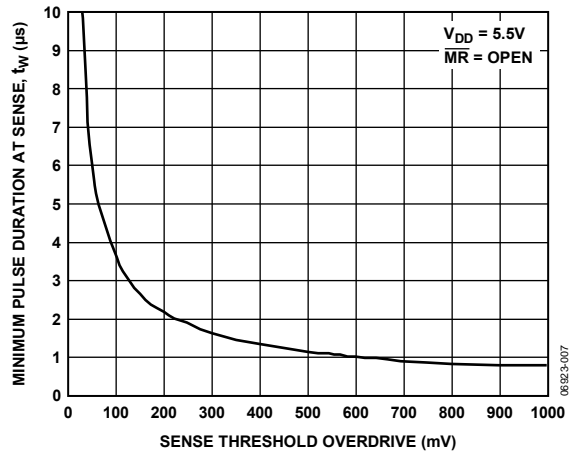

Figure 7. ADM13307-18, ADM13307-25 and ADM13307-33 Minimum Pulse Duration at Sense vs. Sense Threshold Overdrive

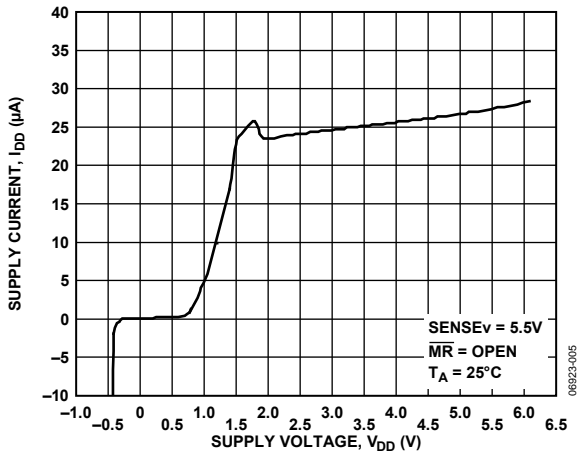

Figure 5. Supply Current vs. Supply Voltage

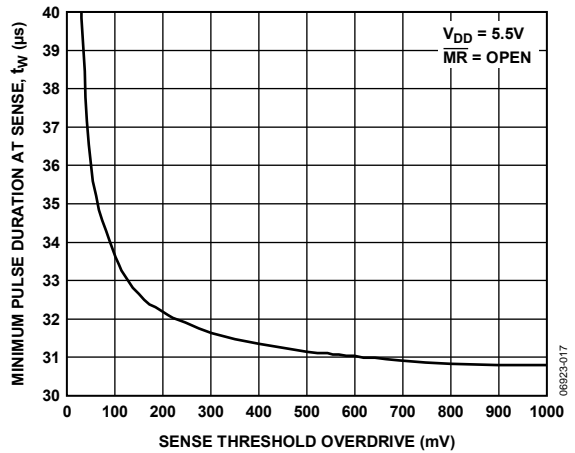

Figure 8. ADM13307-4 and ADM13307-5 Minimum Pulse Duration at Sense vs. Sense Threshold Overdrive

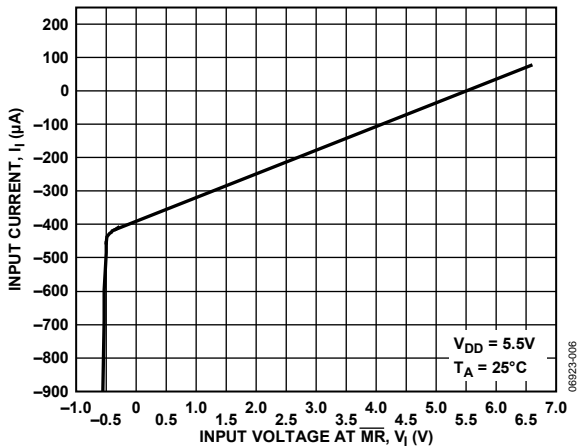

Figure 6. Input Current vs. Input Voltage at  $\overline{MR}$

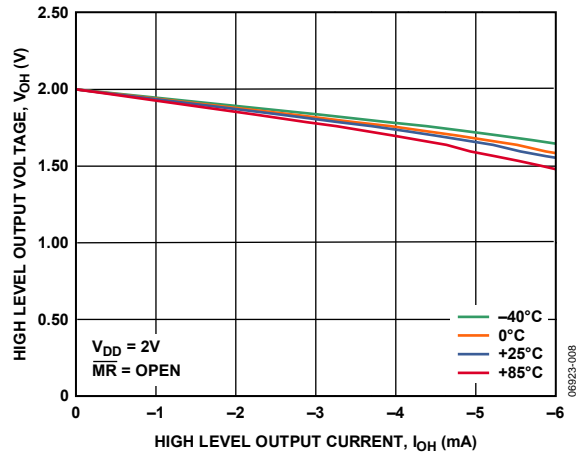

Figure 9. High Level Output Voltage vs. High Level Output Current



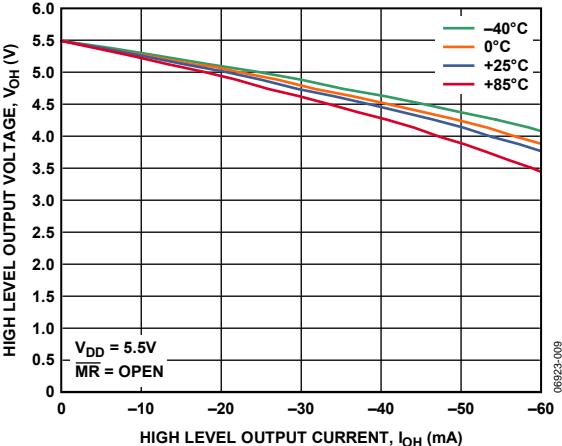

Figure 10. High Level Output Voltage vs. High Level Output Current

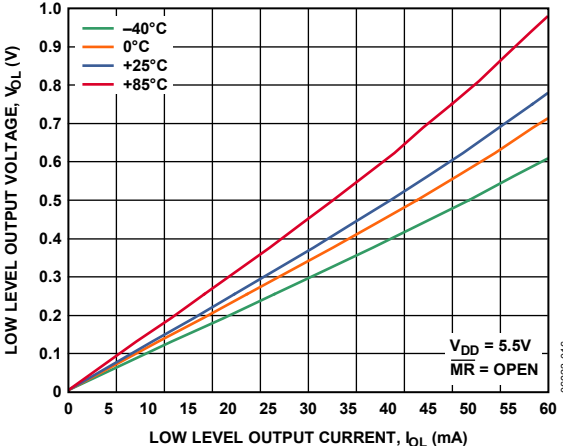

Figure 12. Low Level Output Voltage vs. Low Level Output Current

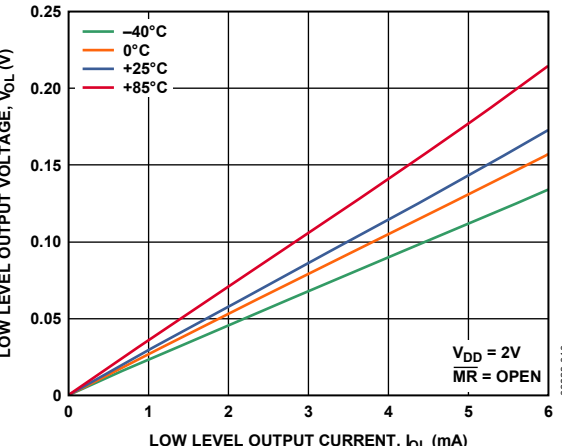

Figure 11. Low Level Output Voltage vs. Low Level Output Current

## THEORY OF OPERATION

The ADM13307 devices are triple voltage supervisors designed to monitor up to three supplies and provide a reset signal to DSP and microprocessor-based systems.

There are five models available, all of which feature a combination of internally pretrimmed undervoltage threshold options for monitoring 1.8 V, 2.5 V, 3.3 V, and 5 V supplies. There are also adjustable input options with threshold voltages of either 0.6 V or 1.25 V.

ADM13307-18, ADM13307-25, and ADM13307-33 models have two internally fixed thresholds and one externally programmable threshold, via a resistor string, while the ADM13307-4 and ADM13307-5 offer one internally fixed threshold and two externally programmable thresholds via a resistor string. See the Ordering Guide for a list of all available options.

### INPUT CONFIGURATION

The ADM13307 is powered through  $V_{DD}$ . To increase noise immunity in noisy applications, place a 0.1  $\mu\text{F}$  capacitor between the  $V_{DD}$  input and ground.

The SENSEv inputs are resistant to short power supply glitches. Do not allow unused SENSEv inputs to float or to be grounded, instead connect it to a supply voltage greater than its specified threshold voltage.

Typically, the threshold voltage at an adjustable SENSEv input is either 0.6 V or 1.25 V. Refer to the Ordering Guide for details.

For example, to monitor a voltage greater than 1.25 V, connect a resistor divider network to the device as depicted in Figure 13, where,

$$V_{MONITORED} = 1.25 \text{ V} \left( \frac{R1 + R2}{R2} \right)$$

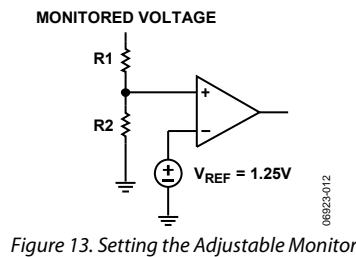

Figure 13. Setting the Adjustable Monitor

### RESET OUTPUT

The reset outputs are guaranteed to be in the correct state for  $V_{DD}$  down to 1.1 V. During power up,  $\overline{\text{RESET}}$  is asserted when the supply voltage becomes greater than 1.1 V.

Once the supplies monitored at the SENSEv pins rise above their associated threshold level, the  $\overline{\text{RESET}}$  signal remains low for the reset timeout period before deasserting. Subsequently, if a supply monitored by the SENSEv pins falls below its associated threshold, the  $\overline{\text{RESET}}$  output reasserts.

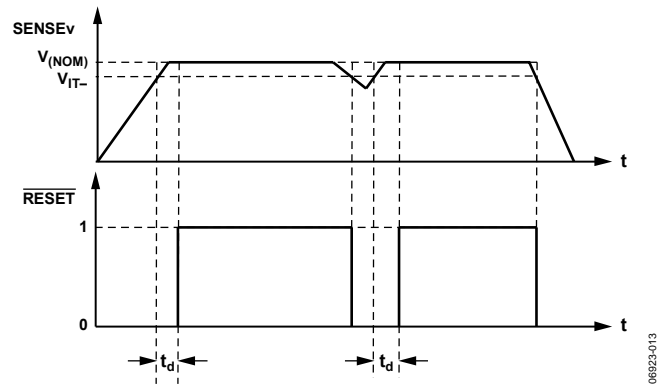

Figure 14. Reset Timing Diagram

The ADM13307 features both an active-low push-pull  $\overline{\text{RESET}}$  output and active-high push-pull RESET output.

### MANUAL RESET ( $\overline{\text{MR}}$ )

The ADM13307 features a manual reset input, which when driven low, asserts the reset output, as shown in Figure 15. When  $\overline{\text{MR}}$  transitions from low to high, the reset remains asserted for the duration of the reset active timeout period before deasserting. An external push-button switch can be connected between  $\overline{\text{MR}}$  and ground to allow the user to generate a reset.

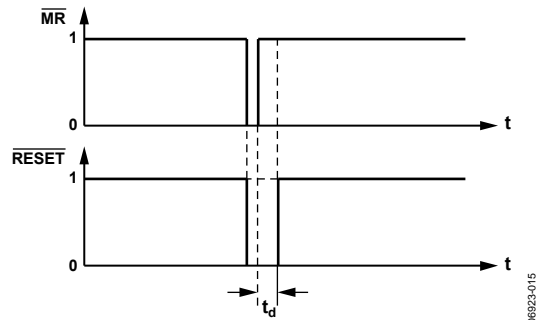
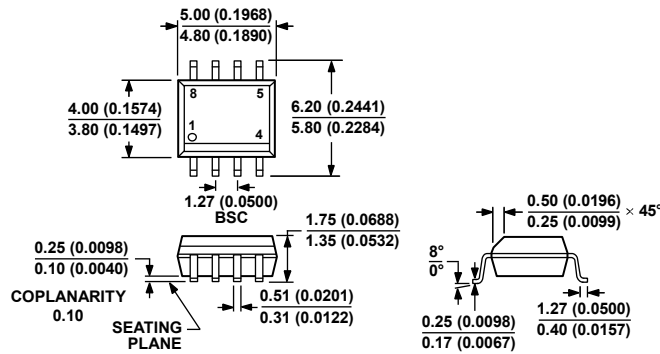

Figure 15. Manual Reset Timing Diagram

# OUTLINE DIMENSIONS



COMPLIANT TO JEDEC STANDARDS MS-012-AA  
 CONTROLLING DIMENSIONS ARE IN MILLIMETERS; INCH DIMENSIONS (IN PARENTHESES) ARE ROUNDED-OFF MILLIMETER EQUIVALENTS FOR REFERENCE ONLY AND ARE NOT APPROPRIATE FOR USE IN DESIGN.

0.12.807-A

Figure 16. 8-Lead Standard Small Outline Package [SOIC\_N] Narrow Body (R-8)

Dimensions shown in millimeters and (inches).

## ORDERING GUIDE

Model	Nominal Input Voltage			Threshold Voltage (Typical)			Temperature Range	Package Description	Package Option
	SENSE1	SENSE2	SENSE3	SENSE1	SENSE2	SENSE3			
ADM13307-18ARZ <sup>1</sup>	3.3 V	1.8 V	Adj <sup>2</sup>	2.93 V	1.68 V	1.25 V	-40°C to +85°C	8-Lead SOIC_N	R-8
ADM13307-18ARZ-RL7 <sup>1</sup>	3.3 V	1.8 V	Adj <sup>2</sup>	2.93 V	1.68 V	1.25 V	-40°C to +85°C	8-Lead SOIC_N	R-8
ADM13307-25ARZ <sup>1</sup>	3.3 V	2.5 V	Adj <sup>2</sup>	2.93 V	2.25 V	1.25 V	-40°C to +85°C	8-Lead SOIC_N	R-8
ADM13307-25ARZ-RL7 <sup>1</sup>	3.3 V	2.5 V	Adj <sup>2</sup>	2.93 V	2.25 V	1.25 V	-40°C to +85°C	8-Lead SOIC_N	R-8
ADM13307-33ARZ <sup>1</sup>	5 V	3.3 V	Adj <sup>2</sup>	4.55 V	2.93 V	1.25 V	-40°C to +85°C	8-Lead SOIC_N	R-8
ADM13307-33ARZ-RL7 <sup>1</sup>	5 V	3.3 V	Adj <sup>2</sup>	4.55 V	2.93 V	1.25 V	-40°C to +85°C	8-Lead SOIC_N	R-8
ADM13307-4ARZ <sup>1</sup>	2.5 V	Adj <sup>3</sup>	Adj <sup>3</sup>	2.25 V	0.6 V	0.6 V	-40°C to +85°C	8-Lead SOIC_N	R-8
ADM13307-4ARZ-RL7 <sup>1</sup>	2.5 V	Adj <sup>3</sup>	Adj <sup>3</sup>	2.25 V	0.6 V	0.6 V	-40°C to +85°C	8-Lead SOIC_N	R-8
ADM13307-5ARZ <sup>1</sup>	3.3 V	Adj <sup>3</sup>	Adj <sup>3</sup>	2.93 V	0.6 V	0.6 V	-40°C to +85°C	8-Lead SOIC_N	R-8
ADM13307-5ARZ-RL7 <sup>1</sup>	3.3 V	Adj <sup>3</sup>	Adj <sup>3</sup>	2.93 V	0.6 V	0.6 V	-40°C to +85°C	8-Lead SOIC_N	R-8

<sup>1</sup> Z = RoHS Compliant Part.

<sup>2</sup> 1.25 V adjustable. External resistor divider determines the actual sense voltage.

<sup>3</sup> 0.6 V adjustable. External resistor divider determines the actual sense voltage.

**ADM13307**

**NOTES**

## X-ON Electronics

Largest Supplier of Electrical and Electronic Components

*Click to view similar products for [Supervisory Circuits](#) category:*

*Click to view products by [Analog Devices](#) manufacturer:*

Other Similar products are found below :

[CAT1161LI-25-G](#) [CAT853STBI-T3](#) [CAT1026LI-30-G](#) [CAT1320LI-25-G](#) [TC54VN2402EMB713](#) [MCP1316T-44NE/OT](#) [MCP1316MT-45GE/OT](#) [MCP1316MT-23LI/OT](#) [MAX8997EWW+](#) [MAX6725AKASYD3-LF-T](#) [DS1232L](#) [NCV302HSN45T1G](#) [PT7M6130NLTA3EX](#) [PT7M7811STBEX-2017](#) [S-1000N28-I4T1U](#) [CAT1161LI-28-G](#) [MCP1321T-29AE/OT](#) [MCP1319MT-47QE/OT](#) [S-1000N23-I4T1U](#) [S-1000N19-I4T1U](#) [CAT824UTDI-GT3](#) [TC54VC2502ECB713](#) [PT7M6133NLTA3EX](#) [PT7M6127NLTA3EX](#) [VDA2510NTA](#) [AP0809ES3-r](#) [HG811RM4/TR](#) [MD7030C](#) [MD7033C](#) [MD7019](#) [MD7020](#) [MD7021](#) [MD7023](#) [MD7024](#) [MD7027](#) [MD7030](#) [MD7033](#) [MD7035](#) [MD7036](#) [MD7039](#) [MD7040](#) [MD7044](#) [MD7050](#) [MD7015](#) [MD7028](#) [MD7031](#) [MD7042](#) [MD7043](#) [MD7047](#) [MD7060](#)