

TABLE OF CONTENTS

Features	1	Control.....	11
Applications.....	1	Voltage Setpoint Calibration.....	11
General Description	1	Resistor Setpoint Calibration.....	13
Applications Diagram	1	I_{MPD} Monitoring	13
Revision History	2	Loop Bandwidth Selection.....	14
Specifications.....	3	Power Consumption	14
SFP Timing Specifications.....	4	Automatic Laser Shutdown (Tx_Disable).....	14
Absolute Maximum Ratings.....	5	Bias and Modulation Monitor Currents.....	14
ESD Caution.....	5	IBIAS Pin	14
Pin Configuration and Function Descriptions.....	6	Data Inputs.....	15
Typical Performance Characteristics	7	Laser Diode Interfacing.....	15
Optical Waveforms	9	Alarms.....	16
Theory of Operation	10	Outline Dimensions	17
Dual-Loop Control.....	10	Ordering Guide	17

REVISION HISTORY

9/2016—Rev. A to Rev. B

Changes to Ordering Guide 17

2/2016—Rev. 0 to Rev. A

Changes to General Description 1
 Changes to Figure 5 and Table 4..... 6
 Updated Outline Dimensions 17

3/2009—Revision 0: Initial Version

SPECIFICATIONS

$V_{CC} = 3.0\text{ V to }3.6\text{ V}$. All specifications T_{MIN} to T_{MAX} , unless otherwise noted.¹ Typical values as specified at 25°C.

Table 1.

Parameter	Min	Typ	Max	Unit	Conditions/Comments
LASER BIAS CURRENT (IBIAS)					
Output Current, I_{BIAS}	2		100	mA	
Compliance Voltage	1.2		V_{CC}	V	
IBIAS when ALS High			0.2	mA	
CCBIAS Compliance Voltage	1.2			V	
MODULATION CURRENT (IMODP, IMODN) ²					
Output Current, I_{MOD}	5		90	mA	
Compliance Voltage	1.5		V_{CC}	V	
I_{MOD} when ALS High			0.05	mA	
Rise Time ^{2,3}		60	104	ps	
Fall Time ^{2,3}		60	96	ps	
Random Jitter ^{2,3}		0.8	1.1	ps rms	
Deterministic Jitter ^{2,3}			35	ps	20 mA < I_{MOD} < 90 mA
Pulse Width Distortion ^{2,3}			30	ps	20 mA < I_{MOD} < 90 mA
AVERAGE POWER SET (PAVSET)					
Pin Capacitance			80	pF	
Voltage	1.1	1.2	1.35	V	
Photodiode Monitor Current (Average Current)	50		1200	μ A	Resistor setpoint mode
EXTINCTION RATIO SET INPUT (ERSET)					
Resistance Range	1.2		25	k Ω	Resistor setpoint mode
Voltage	1.1	1.2	1.35	V	Resistor setpoint mode
AVERAGE POWER REFERENCE VOLTAGE INPUT (PAVREF)					
Voltage Range	0.12		1	V	Voltage setpoint mode (RPAV fixed at 1 k Ω)
Photodiode Monitor Current (Average Current)	120		1000	μ A	Voltage setpoint mode (RPAV fixed at 1 k Ω)
EXTINCTION RATIO REFERENCE VOLTAGE INPUT (ERREF)					
Voltage Range	0.1		1	V	Voltage setpoint mode (R_{ERSET} fixed at 1 k Ω)
DATA INPUTS (DATAP, DATAN) ⁴					
Input Voltage Swing (Differential)	0.4		2.4	V p-p	AC-coupled
Input Impedance (Single-Ended)		50		Ω	
LOGIC INPUTS (ALS)					
V_{IH}	2			V	
V_{IL}			0.8	V	
ALARM OUTPUT (FAIL) ⁵					
V_{OFF}		>1.8		V	Voltage required at FAIL for I_{BIAS} and I_{MOD} to turn off when FAIL asserted
V_{ON}		<1.3		V	Voltage required at FAIL for I_{BIAS} and I_{MOD} to stay on when FAIL asserted
IBMON, IMMON DIVISION RATIO					
I_{BIAS}/I_{BMON} ³	85	100	115	A/A	11 mA < I_{BIAS} < 50 mA
I_{BIAS}/I_{BMON} ³	92	100	108	A/A	50 mA < I_{BIAS} < 100 mA
I_{BIAS}/I_{BMON} Stability ^{3,6}			± 5	%	10 mA < I_{BIAS} < 100 mA
I_{MOD}/I_{MMON}		50		A/A	
I_{BMON} Compliance Voltage	0		1.3	V	

Parameter	Min	Typ	Max	Unit	Conditions/Comments
SUPPLY					
I_{CC}^7		30		mA	When $I_{BIAS} = I_{MOD} = 0$
V_{CC} (with respect to GND) ⁸	3.0	3.3	3.6	V	

¹ Temperature range is -40°C to $+85^{\circ}\text{C}$.

² Measured into a $15\ \Omega$ load ($22\ \Omega$ resistor in parallel with digital scope $50\ \Omega$ input) using a 11110000 pattern at 2.5 Gbps, shown in Figure 2.

³ Guaranteed by design and characterization. Not production tested.

⁴ When the voltage on DATAP is greater than the voltage on DATAN, the modulation current flows into the IMODP pin.

⁵ Guaranteed by design. Not production tested.

⁶ I_{BIAS}/I_{MON} ratio stability is defined in SFF-8472 Revision 9 over temperature and supply variation.

⁷ See the Power Consumption section for I_{CC} minimum for power calculation.

⁸ All VCC pins must be shorted together.

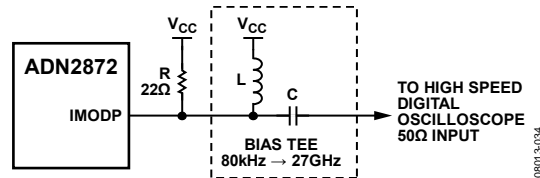

Figure 2. High Speed Electrical Test Output Circuit

SFP TIMING SPECIFICATIONS

Table 2.

Parameter	Symbol	Min	Typ	Max	Unit	Conditions/Comments
ALS Assert Time	t_{off}	1	5		μs	Time for the rising edge of ALS (Tx_DISABLE) to when the bias current falls below 10% of nominal
ALS Negate Time ¹	t_{on}	0.83	0.95		ms	Time for the falling edge of ALS to when the modulation current rises above 90% of nominal
Time to Initialize, Including Reset of FAIL ¹	t_{init}	25	275		ms	From power-on or negation of FAIL using ALS
FAIL Assert Time	t_{fault}		100		μs	Time to fault to FAIL on
ALS to Reset Time	t_{reset}		5		μs	Time Tx_DISABLE must be held high to reset Tx_FAULT

¹ Guaranteed by design and characterization. Not production tested.

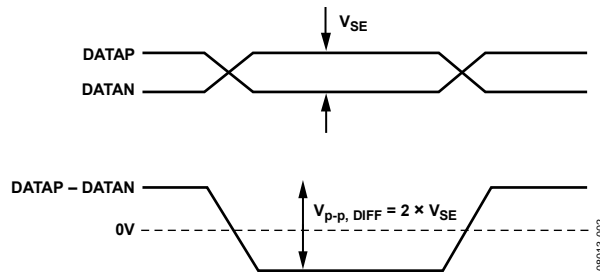

Figure 3. Signal Level Definition

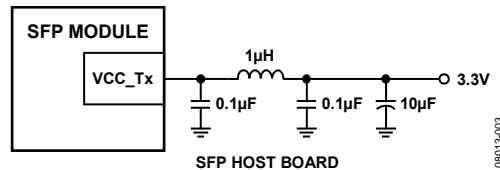

Figure 4. Recommended SFP Supply

ABSOLUTE MAXIMUM RATINGS

$T_A = 25^\circ\text{C}$, unless otherwise noted.

Table 3.

Parameter	Rating
VCC to GND	4.2 V
IMODN, IMODP	-0.3 V to +4.8 V
PAVCAP, ERCAP, PAVSET, PAVREF, ERREF, IBIAS, IBMON, IMMON, ALS, CCBIAS, RPAV, ERSET, FAIL	-0.3 V to +3.9 V
DATAP, DATAN (Single-Ended Differential)	1.5 V
Junction Temperature (T_J max)	125°C
Operating Temperature Range, Industrial	-40°C to +85°C
Storage Temperature Range	-65°C to +150°C
Power Dissipation (W) ¹	$(T_J \text{ max} - T_A)/\theta_{JA}$
θ_{JA} Thermal Impedance ²	48.6°C/W
θ_{JC} Thermal Impedance ²	5.0°C/W
θ_{JB} Thermal Impedance ²	28.4°C/W

¹ Power consumption equations are provided in the Power Consumption section.

² θ_{JA} , θ_{JB} , and θ_{JC} are estimated when the exposed pad on the device is soldered on a 4-layer JEDEC board at zero airflow.

Stresses at or above those listed under Absolute Maximum Ratings may cause permanent damage to the product. This is a stress rating only; functional operation of the product at these or any other conditions above those indicated in the operational section of this specification is not implied. Operation beyond the maximum operating conditions for extended periods may affect product reliability.

ESD CAUTION



ESD (electrostatic discharge) sensitive device. Charged devices and circuit boards can discharge without detection. Although this product features patented or proprietary protection circuitry, damage may occur on devices subjected to high energy ESD. Therefore, proper ESD precautions should be taken to avoid performance degradation or loss of functionality.

PIN CONFIGURATION AND FUNCTION DESCRIPTIONS

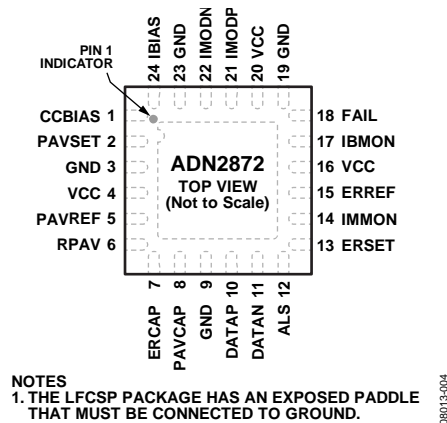

Figure 5. Pin Configuration

Table 4. Pin Function Descriptions

Pin No.	Mnemonic	Description
1	CCBIAS	Control Output Current.
2	PAVSET	Average Optical Power Set Pin.
3	GND	Supply Ground.
4	VCC	Supply Voltage.
5	PAVREF	Reference Voltage Input for Average Optical Power Control.
6	RPAV	Average Power Resistor When Using PAVREF.
7	ERCAP	Extinction Ratio Loop Capacitor.
8	PAVCAP	Average Power Loop Capacitor.
9	GND	Supply Ground.
10	DATAP	Data, Positive Differential Input.
11	DATAN	Data, Negative Differential Input.
12	ALS	Automatic Laser Shutdown.
13	ERSET	Extinction Ratio Set Pin.
14	IMMON	Modulation Current Monitor Current Source.
15	ERREF	Reference Voltage Input for Extinction Ratio Control.
16	VCC	Supply Voltage.
17	IBMON	Bias Current Monitor Current Source.
18	FAIL	FAIL Alarm Output.
19	GND	Supply Ground.
20	VCC	Supply Voltage.
21	IMODP	Modulation Current Positive Output (Current Sink), Connect to Laser Diode.
22	IMODN	Modulation Current Negative Output (Current Sink).
23	GND	Supply Ground.
24	IBIAS	Laser Diode Bias (Current Sink to Ground).
	EPAD	Exposed Pad. The LFCSP package has an exposed pad that must connect to ground.

TYPICAL PERFORMANCE CHARACTERISTICS

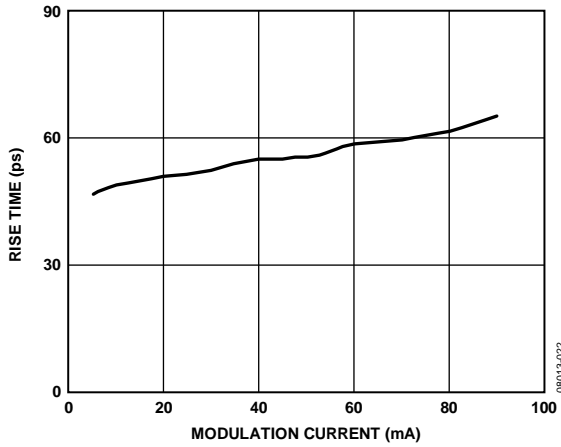

Figure 6. Rise Time vs. Modulation Current, $I_{BIAS} = 20\text{ mA}$

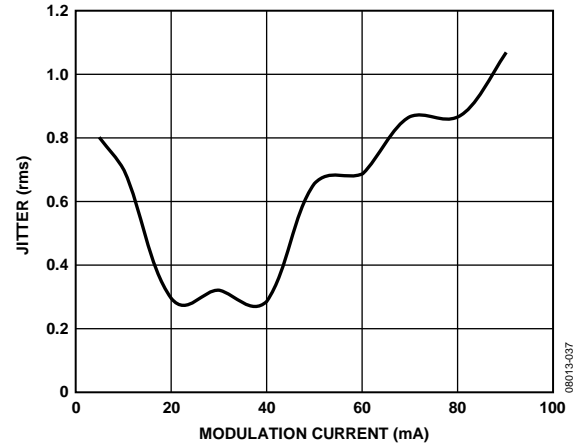

Figure 9. Random Jitter vs. Modulation Current, $I_{BIAS} = 20\text{ mA}$

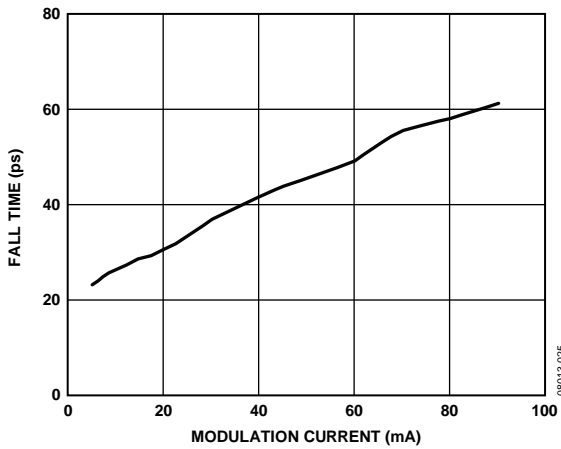

Figure 7. Fall Time vs. Modulation Current, $I_{BIAS} = 20\text{ mA}$

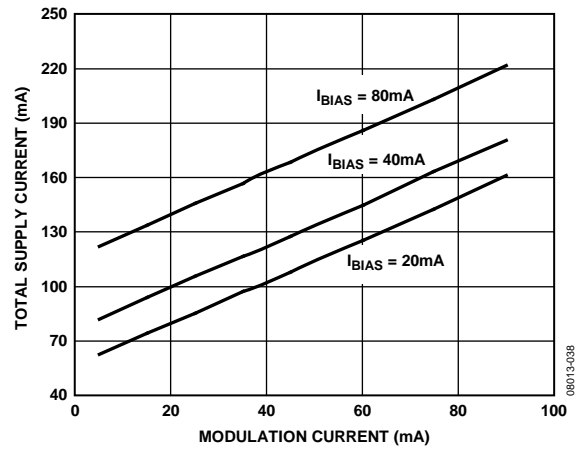

Figure 10. Total Supply Current vs. Modulation Current, $\text{Total Supply Current} = I_{CC} + I_{BIAS} + I_{MOD}$

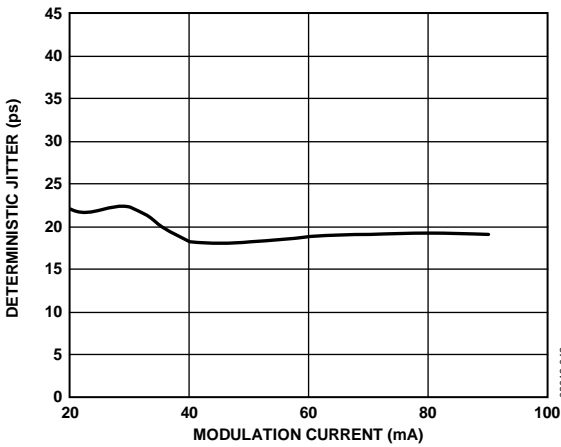

Figure 8. Deterministic Jitter vs. Modulation Current, $I_{BIAS} = 20\text{ mA}$

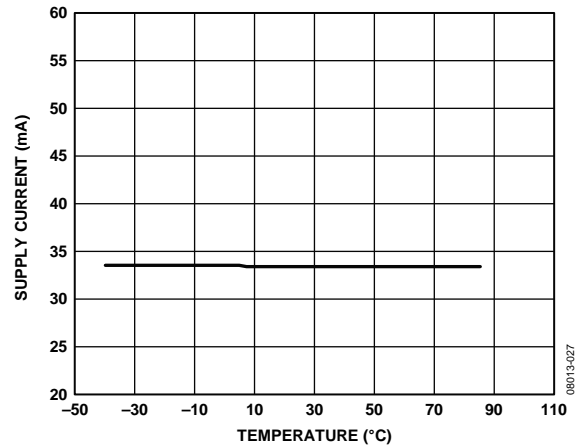

Figure 11. Supply Current (I_{CC}) vs. Temperature with ALS Asserted, $I_{BIAS} = 20\text{ mA}$

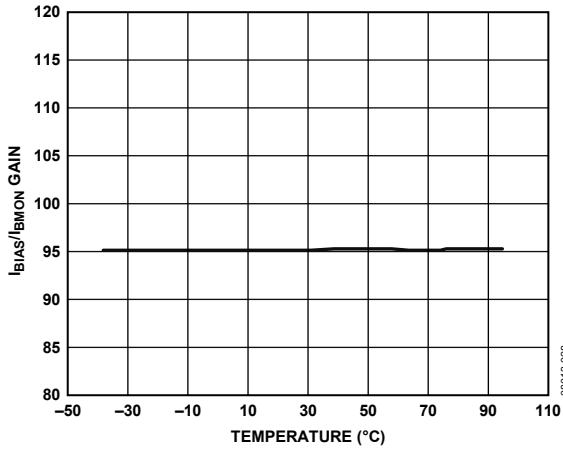

Figure 12. I_{BIAS}/I_{BMON} Gain vs. Temperature, $I_{BIAS} = 20\text{ mA}$

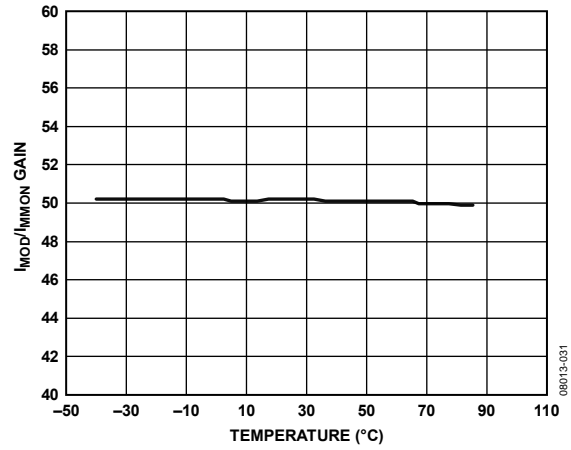

Figure 15. I_{MOD}/I_{MMON} Gain vs. Temperature, $I_{MOD} = 30\text{ mA}$

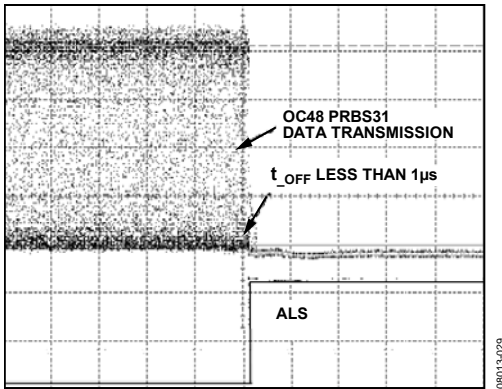

Figure 13. ALS Assert Time, 5 $\mu\text{s}/\text{DIV}$

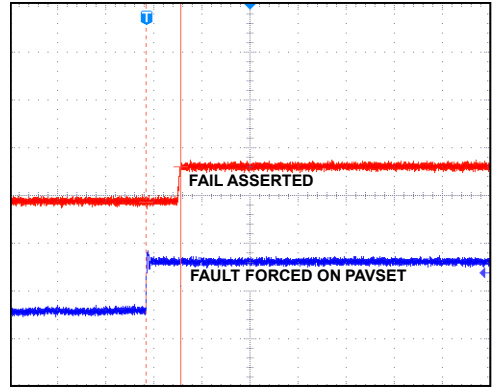

Figure 16. FAIL Assert Time, 1 $\mu\text{s}/\text{DIV}$

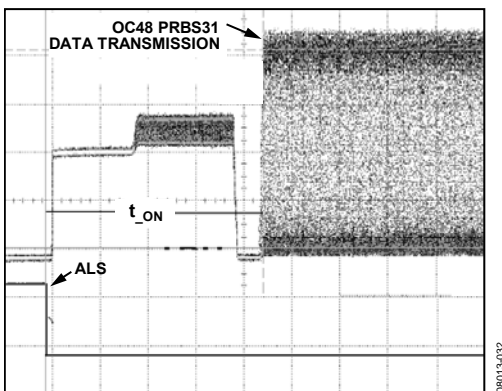

Figure 14. ALS Negate Time, 200 $\mu\text{s}/\text{DIV}$

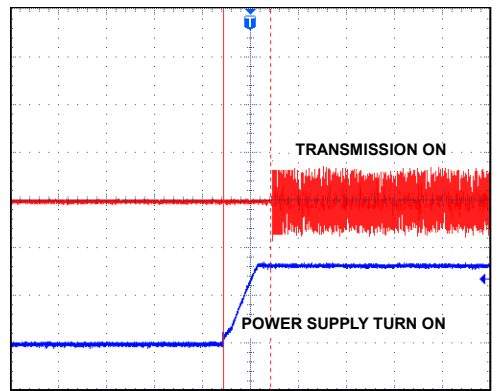

Figure 17. Time to Initialize, Including Reset, 40 ms/DIV

OPTICAL WAVEFORMS

$V_{CC} = 3.3\text{ V}$ and $T_A = 25^\circ\text{C}$, unless otherwise noted. Note that there was no change to PAVCAP and ERCAP values when different data rates were tested. Figure 18, Figure 19, and Figure 20 show multirate performance using the low cost Fabry Perot (FP) TOSA NEC NX7315UA; Figure 21 and Figure 22 show dual-loop performance over temperature using the DFB TOSA Sumitomo SLT2486.

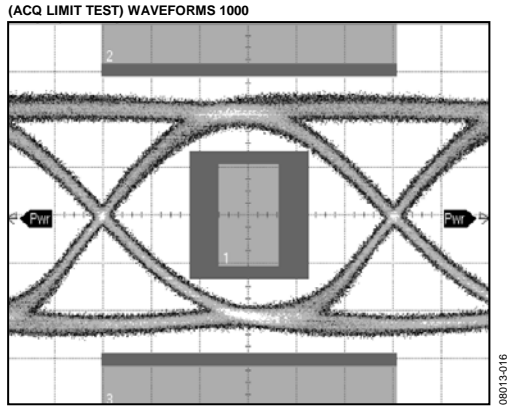

Figure 18. Optical Eye 2.488 Gbps, 65 ps/DIV, PRBS $2^{31} - 1$, PAV = -4.5 dBm, ER = 9 dB, Mask Margin 25%

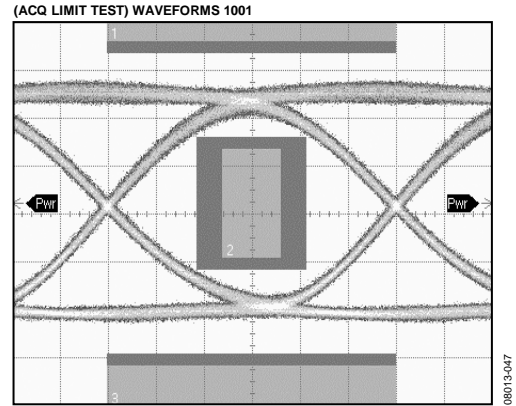

Figure 21. Optical Eye 2.488 Gbps, 65 ps/DIV, PRBS $2^{31} - 1$, PAV = 0 dBm, ER = 9 dB, Mask Margin 22%, $T_A = 25^\circ\text{C}$

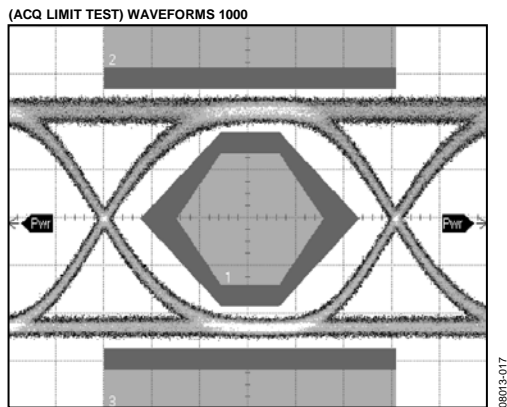

Figure 19. Optical Eye 622 Mbps, 264 ps/DIV, PRBS $2^{31} - 1$, PAV = -4.5 dBm, ER = 9 dB, Mask Margin 50%

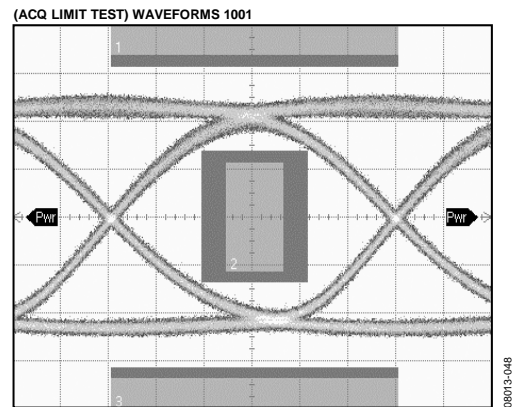

Figure 22. Optical Eye 2.488 Gbps, 65 ps/DIV, PRBS $2^{31} - 1$, PAV = -0.2 dBm, ER = 8.96 dB, Mask Margin 21%, $T_A = 85^\circ\text{C}$

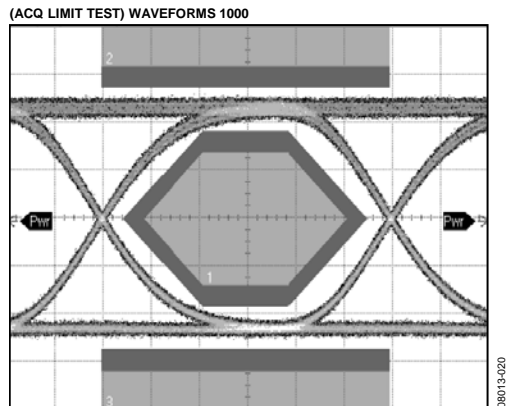

Figure 20. Optical Eye 155 Mbps, 1.078 ns/DIV, PRBS $2^{31} - 1$, PAV = -4.5 dBm, ER = 9 dB, Mask Margin 50%

THEORY OF OPERATION

Laser diodes have a current-in to light-out transfer function, as shown in Figure 23. Two key characteristics of this transfer function are the threshold current, I_{TH} , and slope in the linear region beyond the threshold current, referred to as slope efficiency, LI .

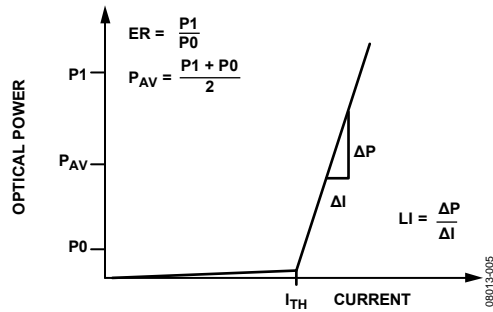

Figure 23. Laser Transfer Function

DUAL-LOOP CONTROL

Typically, laser threshold current and slope efficiency are both functions of temperature. For FP and DFB type lasers, the threshold current increases and the slope efficiency decreases with increasing temperature. In addition, these parameters vary as the laser ages. To maintain a constant optical average power and a constant optical ER over temperature and laser lifetime, it is necessary to vary the applied electrical bias current and modulation current to compensate for the laser changing LI characteristics.

Single-loop compensation schemes use the average monitor photodiode (MPD) current to measure and maintain the average optical output power over temperature and laser aging. The ADN2872 is a dual-loop device, implementing both this primary average power control loop and a secondary control loop, which maintains a constant optical ER. The dual-loop control of the average power and ER implemented in the ADN2872 can be used successfully with both lasers that maintain good linearity of LI transfer characteristics over temperature, and with those that exhibit increasing nonlinearity of the LI characteristics over temperature.

Dual Loop

The ADN2872 uses a proprietary patented method to control both average power and ER. The ADN2872 is constantly sending a test signal on the modulation current signal and reading the resulting change in the MPD current as a means of detecting the slope of the laser in real time. This information is used in a servo to control the ER of the laser, which is done in a time-multiplexed manner at a low frequency, typically 80 Hz. Figure 24 shows the dual-loop control implementation on the ADN2872.

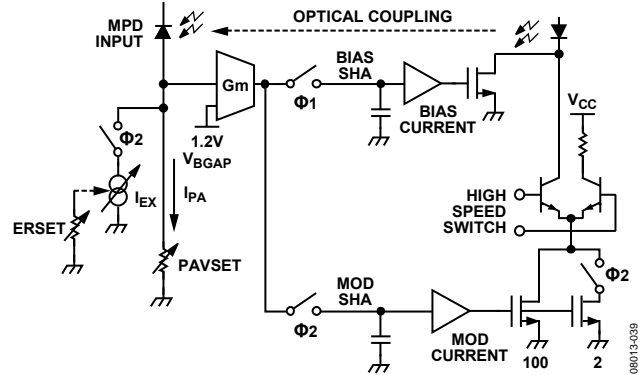

Figure 24. Dual-Loop Control of Average Power and ER

A dual loop is made up of an average power control loop (APCL) and the ER control loop (ERCL), which are separated into two time states. During Time Φ_1 , the APCL is operating, and during Time Φ_2 , the ER loop is operating.

Average Power Control Loop

The APCL compensates for changes in the laser diode (LD), I_{TH} and LI , by varying I_{BIAS} . APC control is performed by measuring the MPD current, I_{MPD} . This current is bandwidth limited by the MPD. This is not a problem because the APCL must be low frequency and the APCL must respond to the average current from the MPD. The APCL compares $I_{MPD} \times R_{PAVSET}$ to the band gap ($BGAP$) voltage, V_{BGAP} . If I_{MPD} falls, the bias current is increased until $I_{MPD} \times R_{PAVSET}$ equals V_{BGAP} . Conversely, if the I_{MPD} increases, I_{BIAS} is decreased.

Modulation Control Loop

The ERCL measures the slope efficiency, LI , of the laser diode by monitoring the I_{MPD} changes. During the ERCL, I_{MPD} is temporarily increased by ΔI_{MOD} . The ratio between I_{MPD} and ΔI_{MOD} is a fixed ratio of 50:1, but during startup, this ratio is increased to decrease settling time.

During ERCL, switching in ΔI_{MOD} causes a temporary increase in average optical power, ΔP_{AV} . However, the APCL is disabled during ERCL, and the increase is kept small enough so as not to disturb the optical eye. When ΔI_{MOD} is switched into the laser circuit, an equal current, I_{EX} , is switched into the PAVSET resistor. The user sets the value of I_{EX} ; this is the ERSET setpoint. If ΔI_{MPD} is too small, the control loop knows that LI has decreased, and increases I_{MPD} and, therefore, ΔI_{MOD} accordingly until ΔI_{MPD} is equal to I_{EX} . The previous control cycle status of the I_{BIAS} and I_{MOD} settings are stored on the hold capacitors, PAVCAP and ERCAP.

The ERCL is constantly measuring the actual LI curve; it compensates for the effects of temperature and for changes in the LI curve due to laser aging. Therefore, the laser can be calibrated once at 25°C so that it can then automatically control the laser over temperature. This eliminates the expensive and time consuming temperature calibration of a laser.

Operation with Lasers with Temperature-Dependent Nonlinearity of Laser LI Curve

The ADN2872 ERCL extracts information from the monitor photodiode signal relating to the slope of the LI characteristics at the Optical 1 level (P1). For lasers with good linearity over temperature, the slope measured by the ADN2872 at the Optical 1 level is representative of the slope anywhere on the LI curve. This slope information sets the required modulation current to achieve the required optical ER.

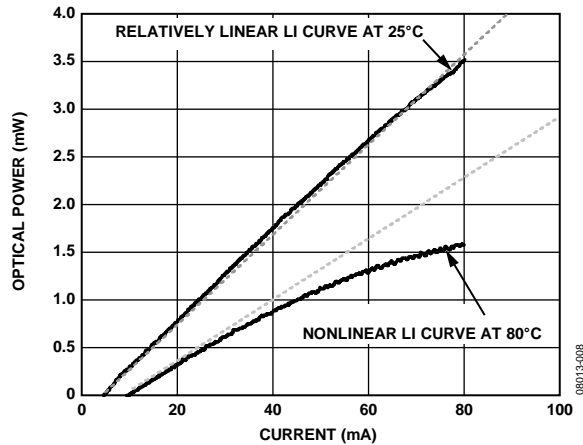

Figure 25. Measurement of a Laser LI Curve Showing Laser Nonlinearity at High Temperatures

Some types of lasers have LI curves that become progressively more nonlinear with increasing temperature (see Figure 25). At temperatures where the LI curve shows significant nonlinearity, the LI curve slope measured by the ADN2872 at the Optical 1 level is no longer representative of the overall LI curve. It is evident that applying a modulation current based on this slope information cannot maintain a constant ER over temperature.

However, the ADN2872 can be configured to maintain near constant optical bias and an ER with a laser exhibiting a monotonic temperature-dependent nonlinearity. To implement this correction, it is necessary to characterize a small sample of lasers for their typical nonlinearity by measuring them at two temperature points, typically 25°C and 85°C. The measured nonlinearity determines the amount of feedback to apply.

Typically, the user must characterize five to 10 lasers of a particular model to obtain a good number. The product can then be calibrated at 25°C only, avoiding the expense of temperature calibration. Typically, the microcontroller measures the laser and apply the feedback. This scheme is particularly suitable for circuits that already use a microcontroller for control and digital diagnostic monitoring.

The ER correction scheme, while using the average nonlinearity for the laser population, supplies a corrective measurement based on the actual performance of each laser as measured during operation. The ER correction scheme corrects for errors due to laser nonlinearity while the dual loop continues to adjust for changes in the Laser LI.

For more details on maintaining average optical power and ER over temperature when working with lasers displaying a temperature-dependent nonlinearity of LI curve, contact sales at Analog Devices.

CONTROL

The ADN2872 has two methods for setting the average power (P_{AV}) and ER. The average power and ER can be voltage set using the voltage DAC outputs of a microcontroller to provide controlled reference voltages to PAVREF and ERREF. Alternatively, the average power and ER can be resistor set using potentiometers at the PAVSET and ERSET pins, respectively.

VOLTAGE SETPOINT CALIBRATION

The ADN2872 allows an interface to a microcontroller for both control and monitoring (see Figure 26). The average power at the PAVSET pin and ER at the ERSET pin can be set using the DAC of the microcontroller to provide controlled reference voltages to PAVREF and ERREF. Note that during power-up, there is an internal sequence that allows 25 ms before enabling the alarms; therefore, the user must ensure that the voltage for PAVREF and ERREF are active within 20 ms.

$$PAVREF = P_{AV} \times R_{SP} \times R_{PAV} \quad (V)$$

$$ERREF = R_{ERSET} \times \frac{I_{MPD_CW}}{P_{CW}} \times \frac{ER - 1}{ER + 1} \times P_{AV} \quad (V)$$

where:

P_{AV} (mW) is the average power required.

ER is the desired extinction ratio ($ER = P1/P0$).

R_{SP} (A/W) is the monitor photodiode responsivity.

I_{MPD_CW} (mA) is the MPD current at that specified PCW.

P_{CW} (mW) is the dc optical power specified on the laser data sheet.

In voltage setpoint, RPAV and R_{ERSET} must be 1 kΩ resistors with a 1% tolerance and a temperature coefficient of 50 ppm/°C.

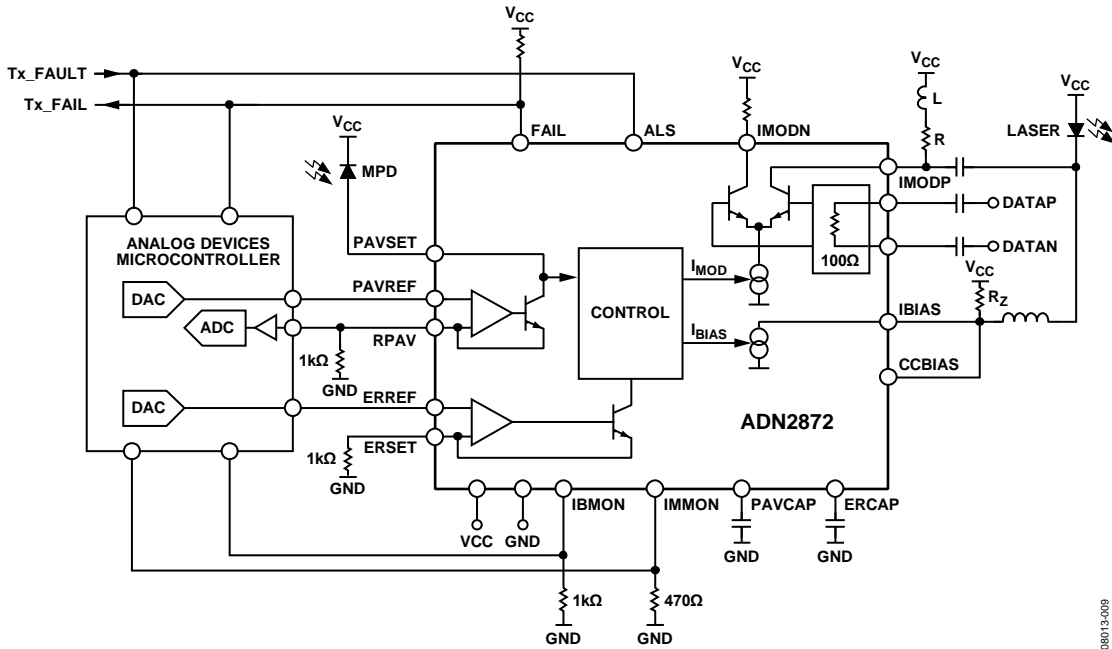

Figure 26. ADN2872 Using MicroConverter Calibration and Monitoring

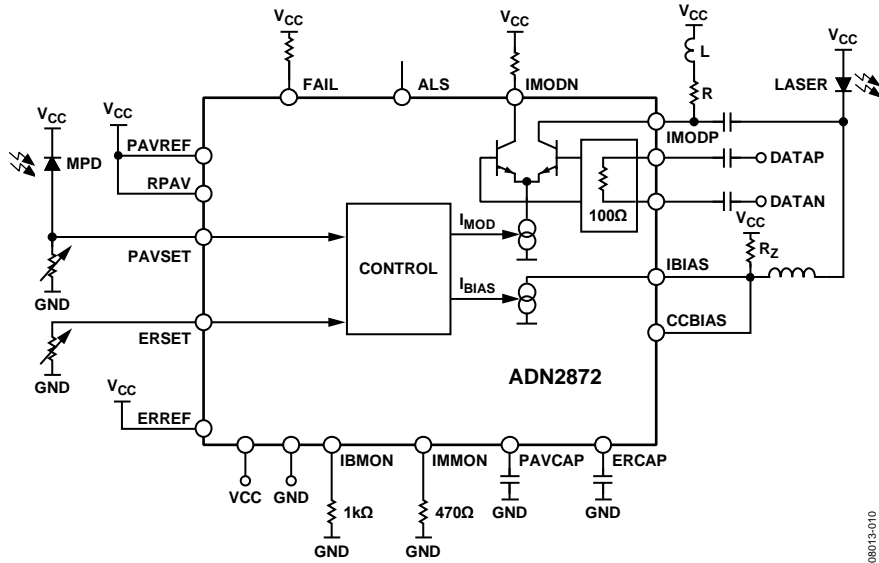

Figure 27. ADN2872 Using Resistor Setpoint Calibration of Average Power and Energy Ratio

RESISTOR SETPOINT CALIBRATION

In resistor setpoint calibration, the PAVREF, ERREF, and RPAV pins must all be tied to VCC. Average power and ER can be set using the PAVSET and ERSET pins, respectively. A resistor is placed between the pin and GND to set the current flowing in each pin, as shown in Figure 27. The ADN2872 ensures that both PAVSET and ERSET are kept 1.2 V above GND. The PAVSET and ERSET resistors are given by

$$R_{PAVSET} = \frac{1.23 \text{ V}}{P_{AV} \times R_{SP}} \quad (\Omega)$$

$$R_{ERSET} = \frac{1.23 \text{ V}}{\frac{I_{MPD_CW}}{P_{CW}} \times \frac{ER - 1}{ER + 1} \times P_{AV}} \quad (\Omega)$$

where:

P_{AV} (mW) is the average power required.

R_{SP} (A/W) is the monitor photodiode responsivity.

P_{CW} (mW) is the dc optical power specified on the laser data sheet.

I_{MPD_CW} (mA) is the MPD current at that specified PCW.

ER is the desired extinction ratio ($ER = P1/P0$).

I_{MPD} MONITORING

I_{MPD} monitoring can be implemented for voltage setpoint and resistor setpoint as follows.

Voltage Setpoint

In voltage setpoint calibration, the following methods can be used for I_{MPD} monitoring.

Method 1: Measuring Voltage at RPAV

The I_{MPD} current is equal to the voltage at RPAV divided by the value of RPAV (see Figure 28) as long as the laser is on and is being controlled by the control loop. This method does not provide a valid I_{MPD} reading when the laser is in shutdown or fail mode. A microconverter-buffered ADC input can be connected to RPAV to make this measurement. No decoupling or filter capacitors must be placed on the RPAV node because this can disturb the control loop.

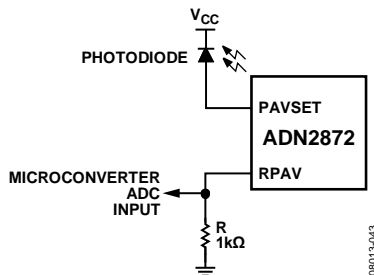

Figure 28. Single Measurement of I_{MPD} at RPAV in Voltage Setpoint Mode

Method 2: Measuring I_{MPD} Across a Sense Resistor

The second method has the advantage of providing a valid I_{MPD} reading at all times but has the disadvantage of requiring a differential measurement across a sense resistor directly in series with the I_{MPD} . As shown in Figure 29, a small resistor, Rx, is placed in series with the I_{MPD} . If the laser used in the design has a pinout where the monitor photodiode cathode and the lasers anode are not connected, a sense resistor can be placed in series with the photodiode cathode and VCC, as shown in Figure 30. When choosing the value of the resistor, the user must take into account the expected I_{MPD} value in normal operation. The resistor must be large enough to make a significant signal for the buffered ADC to read, but small enough not to cause a significant voltage reduction across the I_{MPD} . The voltage across the sense resistor must not exceed 250 mV when the laser is in normal operation. It is recommended that a 10 pF capacitor be placed in parallel with the sense resistor.

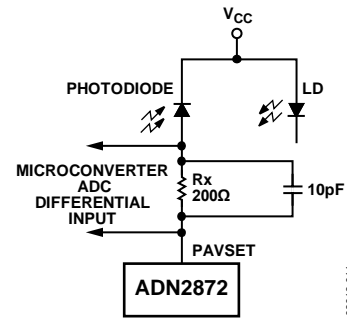

Figure 29. Differential Measurement of I_{MPD} Across a Sense Resistor

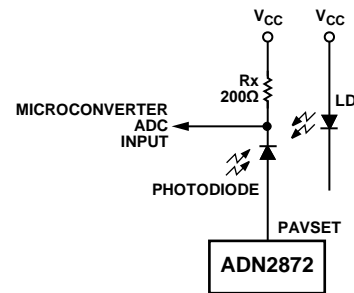

Figure 30. Single Measurement of I_{MPD} Across a Sense Resistor

Resistor Setpoint

In resistor setpoint calibration, the current through the resistor from PAVSET to ground is the I_{MPD} current. The recommended method for measuring the I_{MPD} current is to place a small resistor in series with the PAVSET resistor (or potentiometer) and measure the voltage across this resistor, as shown in Figure 31. The I_{MPD} current is then equal to this voltage divided by the value of the resistor used. In resistor setpoint, PAVSET is held to 1.2 V nominal; it is recommended that the sense resistor must be selected so that the voltage across the sense resistor does not exceed 250 mV.

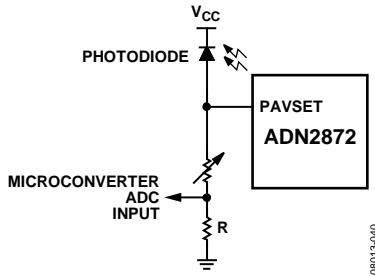

Figure 31. Single Measurement of I_{MOD} Across a Sense Resistor in Resistor Setpoint I_{MOD} Monitoring

LOOP BANDWIDTH SELECTION

To ensure that the ADN2872 control loops have sufficient bandwidth, the average power loop capacitor (PAVCAP) and the ER loop capacitor (ERCAP) are calculated using the laser slope efficiency and the average power required.

For resistor setpoint control,

$$PAVCAP = 3.2 \times 10^{-6} \times \frac{LI}{P_{AV}} \quad (\text{Farad})$$

$$ERCAP = \frac{PAVCAP}{2} \quad (\text{Farad})$$

For voltage setpoint control,

$$PAVCAP = 1.28 \times 10^{-6} \times \frac{LI}{P_{AV}} \quad (\text{Farad})$$

$$ERCAP = \frac{PAVCAP}{2} \quad (\text{Farad})$$

where:

P_{AV} (mW) is the average power required.

LI (mW/mA) is the typical slope efficiency at 25°C of a batch of lasers that are used in a design.

The preceding capacitor estimation formulas obtain a centered value for the particular type of laser that is used in a design and average power setting. Laser LI can vary by a factor of 7 between different physical lasers of the same type and across temperature without the need to recalculate the PAVCAP and ERCAP values.

In the ac coupling configuration, LI can be calculated as

$$LI = \frac{P1 - P0}{I_{MOD}} \quad (\text{mW/mA})$$

where $P1$ is the optical power (mW) at the one level and $P0$ is the optical power (mW) at the zero level.

These capacitors are placed between the PAVCAP and ERCAP pins and ground. It is important that these capacitors are low leakage multilayer ceramics with an insulation resistance greater than 100 GΩ or a time constant of 1000 sec, whichever is less. The capacitor tolerance can be ±30% from the calculated value to the available off the shelf value, including the tolerance of the capacitor.

POWER CONSUMPTION

The ADN2872 die temperature must be kept below 125°C. The LFCSP package has an exposed paddle that must be connected such that it is at the same potential as the ADN2872 ground pins. Power consumption can be calculated as:

$$I_{CC} = I_{CC \text{ min}} + 0.3 I_{MOD}$$

$$P = V_{CC} \times I_{CC} + (I_{BIAS} \times V_{BIAS_PIN}) + I_{MOD} (V_{MODP_PIN} + V_{MODN_PIN})/2$$

$$T_{DIE} = T_{AMBIENT} + \theta_{JA} \times P$$

where:

$I_{CC \text{ min}}$ is 30 mA, the typical value of I_{CC} provided in Table 1 with $I_{BIAS} = I_{MOD} = 0$.

T_{DIE} is the die temperature.

$T_{AMBIENT}$ is the ambient temperature.

V_{BIAS_PIN} is the voltage at the IBIAS pin.

V_{MODP_PIN} is the voltage at the IMODP pin.

V_{MODN_PIN} is the voltage at the IMODN pin.

Thus, the maximum combination of $I_{BIAS} + I_{MOD}$ must be calculated.

AUTOMATIC LASER SHUTDOWN (Tx_DISABLE)

ALS (Tx_DISABLE) is an input that shuts down the transmitter optical output. The ALS pin is pulled up internally with a 6 kΩ resistor and conforms to SFP MSA specifications. When ALS is logic high or open, both the bias and modulation currents are turned off.

BIAS AND MODULATION MONITOR CURRENTS

IBMON and IMMON are current-controlled current sources that mirror a ratio of the bias and modulation current. The monitor bias current, IBMON, and the monitor modulation current, IMMON, must both be connected to ground through a resistor to provide a voltage proportional to the bias current and modulation current, respectively. When using a microcontroller, the voltage developed across these resistors can be connected to two of the ADC channels, making available a digital representation of the bias and modulation current.

IBIAS PIN

ADN2872 has one on-chip, 800 Ω pull-up resistor. The current sink from this resistor is V_{IBIAS} dependent.

$$I_{UP} = \frac{V_{CC} - V_{IBIAS}}{0.8} \quad (\text{mA})$$

where V_{IBIAS} is the voltage measured at the IBIAS pin after setup of one laser bias current, I_{BIAS} . Usually, when set up, a maximum laser bias current of 100 mA results in a V_{IBIAS} of about 1.2 V. In a worst-case scenario, $V_{CC} = 3.6$ V, $V_{IBIAS} = 1.2$ V, and $I_{UP} \leq 3$ mA.

This on-chip resistor helps to damp out the low frequency oscillation observed from some inexpensive lasers. If the on-chip resistance does not provide enough damping, one external R_z may be necessary (see Figure 32 and Figure 33).

DATA INPUTS

Data inputs must be ac-coupled (10 nF capacitors are recommended) and are terminated via a 100 Ω internal resistor between the DATAP and DATAN pins. A high impedance circuit sets the common-mode voltage and is designed to allow maximum input voltage headroom over temperature. It is necessary to use ac coupling to eliminate the need for matching between common-mode voltages.

LASER DIODE INTERFACING

The schematic in Figure 32 describes the recommended circuit for interfacing the ADN2872 to most TO-Can or coax lasers. These lasers typically have impedances of 5 Ω to 7 Ω and have axial leads. The circuit shown works over the full range of data rates from 155 Mbps to 3.3 Gbps including multirate operation (with no change to PAVCAP and ERCAP values); see Figure 18, Figure 19, and Figure 20 in the Typical Performance Characteristics section for multirate performance examples. Coax lasers have special characteristics that make them difficult to interface to. They tend to have higher inductance, and their impedance is not well controlled. The circuit in Figure 32 operates by deliberately mismaturing the transmission line on the laser side, while providing a very high quality matching network on the driver side. The impedance of the driver side matching network is very flat vs. frequency and enables multirate operation. A series damping resistor must not be used.

The 30 Ω transmission line used is a compromise between drive current required and total power consumed. Other transmission line values can be used, with some modification of the component values. The R and C snubber values in Figure 32, 24 Ω and 2.2 pF, respectively, represent a starting point and must be tuned for the particular model of laser being used. R_p, the pull-up resistor, is in series with a very small (0.5 nH) inductor. In some cases, an inductor is not required or can be accommodated with deliberate parasitic inductance, such as a thin trace or a via placed on the PC board.

Take care to mount the laser as close as possible to the PC board, minimizing the exposed lead length between the laser can and the edge of the board. The axial lead of a coax laser is very inductive (approximately 1 nH per millimeter). Long exposed leads result in slower edge rates and reduced eye margin.

Recommended component layouts and gerber files are available by contacting sales at Analog Devices. Note that the circuit in Figure 32 can supply up to 56 mA of modulation current to the laser, sufficient for most lasers available today. Higher currents can be accommodated by changing transmission lines and backmatch values. This interface circuit is not recommended for butterfly-style lasers or other lasers with 25 Ω characteristic impedance. Instead, a 25 Ω transmission line and inductive (instead of resistive) pull-up is recommended. Contact sales for recommendations on transmission lines and backmatch values.

The ADN2872 also supports differential drive schemes. These can be particularly useful when driving VCSELs or other lasers with slow fall times. Differential drive can be implemented by adding a few extra components. A possible implementation is shown in Figure 33.

In Figure 32 and Figure 33, Resistor R_Z is required to achieve optimum eye quality. The recommended value is approximately 200 Ω ~ 500 Ω.

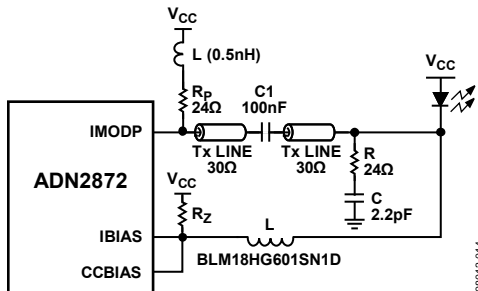
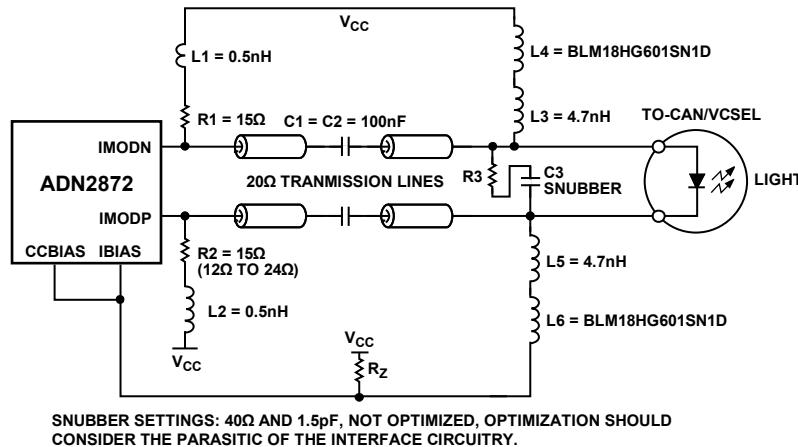

Figure 32. Recommended Interface for ADN2872 AC Coupling



SNUBBER SETTINGS: 40Ω AND 1.5pF, NOT OPTIMIZED, OPTIMIZATION SHOULD CONSIDER THE PARASITIC OF THE INTERFACE CIRCUITRY.

Figure 33. Recommended Differential Drive Circuit

ALARMS

The ADN2872 has a latched active high monitoring alarm (FAIL). The FAIL alarm output is an open drain in conformance with SFP MSA specification requirements.

The ADN2872 has a three-fold alarm system that covers:

- Use of a bias current higher than expected, likely as a result of laser aging.
- Out-of-bounds average voltage at the monitor photodiode (MPD) input, indicating an excessive amount of laser power or a broken loop.
- Undervoltage in the IBIAS pin (laser diode cathode) that increases the laser power.

The bias current alarm trip point is set by selecting the value of resistor on the IBMON pin to GND. The alarm is triggered when the voltage on the IBMON pin goes above 1.2 V.

FAIL is activated when the single-point faults in Table 5 occur.

Table 5. ADN2872 Single-Point Alarms

Alarm Type	Mnemonic	Overvoltage or Short to V _{CC} Condition	Undervoltage or Short to GND Condition
Bias Current	IBMON	Alarm if > 1.2 V	Ignore
MPD Current	PAVSET	Alarm if > 2.0 V	Alarm if < 0.4 V
Crucial Nodes	ERREF (the ERREF is designed tied to V _{CC} in resistor setting mode)	Alarm if shorted to V _{CC} (the alarm is valid for voltage setting mode only)	Alarm if shorted to GND
	IBIAS	Ignore	Alarm if < 0.6 V

Table 6. ADN2872 Response to Various Single-Point Faults in AC-Coupled Configuration, as Shown in Figure 32

Mnemonic	Short to V _{CC}	Short to GND	Open
CCBIAS	Fault state occurs	Fault state occurs	Does not increase laser average power
PAVSET	Fault state occurs	Fault state occurs	Fault state occurs
PAVREF	Voltage mode: fault state occurs Resistor mode: tied to V _{CC}	Fault state occurs	Fault state occurs
RPAV	Voltage mode: fault state occurs Resistor mode: tied to V _{CC}	Fault state occurs	Voltage mode: fault state occurs Resistor mode: does not increase average power
ERCAP	Does not increase laser average power	Does not increase laser average power	Does not increase laser average power
PAVCAP	Fault state occurs	Fault state occurs	Fault state occurs
DATAP	Does not increase laser average power	Does not increase laser average power	Does not increase laser average power
DATAN	Does not increase laser average power	Does not increase laser average power	Does not increase laser average power
ALS	Output currents shut off	Normal currents	Output currents shut off
ERSET	Does not increase laser average power	Does not increase laser average power	Does not increase laser average power
IMMON	Does not affect laser power	Does not increase laser average power	Does not increase laser average power
ERREF	Voltage mode: fault state occurs	Voltage mode: does not increase average power	Does not increase laser average power
	Resistor mode: tied to V _{CC}	Resistor mode: fault state occurs	
IBMON	Fault state occurs	Does not increase laser average power	Does not increase laser average power
FAIL	Fault state occurs	Does not increase laser average power	Does not increase laser average power
IMODP	Does not increase laser average power	Does not increase laser average power	Does not increase laser average power
IMODN	Does not increase laser average power	Does not increase laser average power	Does not increase laser power
IBIAS	Fault state occurs	Fault state occurs	Fault state occurs

OUTLINE DIMENSIONS

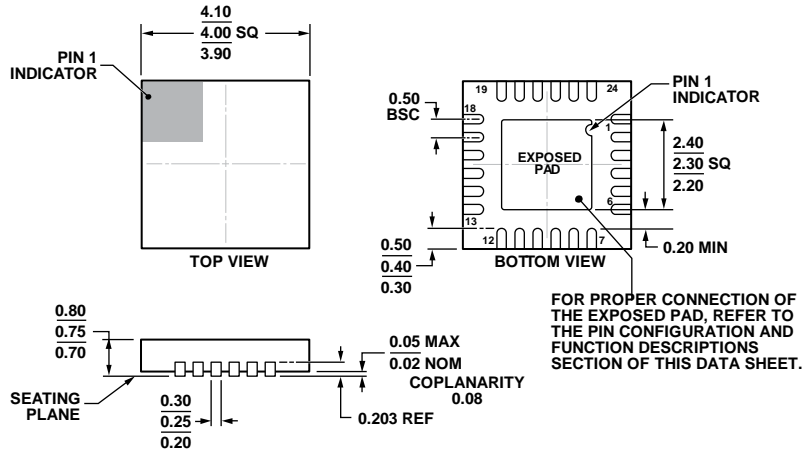

COMPLIANT TO JEDEC STANDARDS MO-220-WGGD-8.

Figure 34. 24-Lead Lead Frame Chip Scale Package [LFCSP]
4 mm × 4 mm Body and 0.75 mm Package Height
(CP-24-14)

Dimensions shown in millimeters

01-18-2012-A

ORDERING GUIDE

Model ¹	Temperature Range	Package Description	Package Option	Ordering Quantity
ADN2872ACPZ	-40°C to +85°C	24-Lead Lead Frame Chip Scale Package [LFCSP]	CP-24-14	490
ADN2872ACPZ-R7	-40°C to +85°C	24-Lead Lead Frame Chip Scale Package [LFCSP]	CP-24-14	1500

¹ Z = RoHS Compliant Part.

NOTES

NOTES

NOTES

X-ON Electronics

Largest Supplier of Electrical and Electronic Components

Click to view similar products for [Laser Drivers](#) category:

Click to view products by [Analog Devices](#) manufacturer:

Other Similar products are found below :

[AXXSATADVDRWROM937575 937575](#) [ADN2872ACPZ](#) [AD9665ACPZ-REEL7](#) [ADN2830ACPZ32](#) [ADN2841ACPZ-48](#) [ADN2847ACPZ-32](#) [ADN2841ACPZ-32](#) [HMC7144LC4](#) [HMC7144LC4TR](#) [HMC7150LP3DE](#) [HMC7810ALC3](#) [DS1873T+](#) [DS1874T+](#) [MAX3946ETG+T](#) [MAX3740AETG+T](#) [MAX3735AETG+T](#) [MAX3643ETG+T](#) [MAX3646ETG+](#) [MAX3656ETG+](#) [MAX3740AETG+](#) [MAX3949ETE+](#) [MAX3949ETE+T](#) [MAX3736ETE+T](#) [MAX3869ETJ](#) [MAX3798ETJ+](#) [MAX3737ETJ+](#) [DS1863E](#) [SY88422LMG](#) [MAX3669EHJ](#) [SY88992LMG-TR](#) [SY84782UMG](#) [SY88022ALMG](#) [SY88992LMG](#) [SY88236LMG](#) [SY88432LMG-TR](#) [SY88432LMG](#) [ONET1151LRGET](#) [ONET1151PRGTT](#) [ONET4201LDRGER](#) [ONET4201LDRGET](#) [ONET4211LDRGET](#) [ONET1101LRGER](#) [ONET1151LRGER](#) [ONET8501VRGPT](#) [MAX3948ETE](#) [MAX3946ETG+](#) [MAX3996CTP+](#) [MAX24002TL+](#) [DS1864T+](#) [DS1862B](#)