

FEATURES

- isoPower* integrated, isolated dc-to-dc converter
- 100 mA output supply
- Meets CISPR 32/EN55032 Class B emission limits up to 5 Mbps at a full load on a 2-layer PCB
- Quad dc to 100 Mbps signal isolation channels
- 28-lead, fine pitch, SOIC with 8.3 mm minimum creepage
- High temperature operation: 125°C maximum
- High common-mode transient immunity: 100 kV/μs
- Safety and regulatory approvals** (pending)
 - UL recognition (pending)
 - 5000 V rms for 1 minute per UL 1577
 - CSA Component Acceptance Notice 5A (pending)
 - VDE V 0884-11 certificate of conformity (pending)
 - $V_{ORM} = 566$ V peak

APPLICATIONS

- RS-232 transceivers
- Power supply start-up bias and gate drives
- Isolated sensor interfaces
- Industrial programmable logic controllers (PLCs)

GENERAL DESCRIPTION

The ADuM6420A/ADuM6421A/ADuM6422A¹ are quad-channel digital isolators with an *isoPower*[®], integrated, isolated dc-to-dc converter. Based on the Analog Devices, Inc., *iCoupler*[®] technology, the dc-to-dc converter provides regulated, isolated power that meets CISPR 32/EN 55032 Class B limits at a full load on a 2-layer printed circuit board (PCB) with ferrites. Popular voltage combinations and the associated output current levels are listed in Table 1.

The ADuM6420A/ADuM6421A/ADuM6422A eliminate the need for a separate, isolated dc-to-dc converter in 500 mW, isolated designs. The *iCoupler* chip scale transformer technology is used for isolated logic signals and for the magnetic components of the dc-to-dc converter. The result is a small form factor, total isolation solution.

¹ Protected by U.S. Patents 5,952,849; 6,873,065; 6,903,578; and 7,075,329. Other patents are pending.

Rev. A **Document Feedback**
 Information furnished by Analog Devices is believed to be accurate and reliable. However, no responsibility is assumed by Analog Devices for its use, nor for any infringements of patents or other rights of third parties that may result from its use. Specifications subject to change without notice. No license is granted by implication or otherwise under any patent or patent rights of Analog Devices. Trademarks and registered trademarks are the property of their respective owners.

FUNCTIONAL BLOCK DIAGRAM

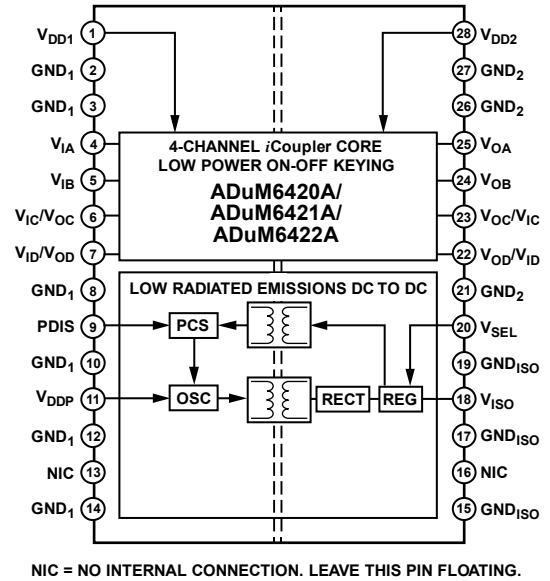

Figure 1.

The ADuM6420A/ADuM6421A/ADuM6422A isolators provide four independent isolation channels (see the Pin Configurations and Function Descriptions for additional information).

Table 1. ADuM6420A/ADuM6421A/ADuM6422A Output Current Levels

| V _{DDP} (V) | V _{ISO} (V) | ISO Current, I _{iso} (mA) | | |
|----------------------|----------------------|------------------------------------|-------|-------|
| | | 85°C | 105°C | 125°C |
| 5 | 5 | 100 | 65 | 30 |
| 5 | 3.3 | 100 | 65 | 30 |
| 3.3 | 3.3 | 60 | 60 | 20 |

TABLE OF CONTENTS

| | | | |
|---|----|---|----|
| Features | 1 | Insulation and Safety Related Specifications..... | 11 |
| Applications | 1 | DIN V VDE V 0884-11 Insulation Characteristics..... | 12 |
| Functional Block Diagram | 1 | Recommended Operating Conditions | 12 |
| General Description | 1 | Absolute Maximum Ratings | 13 |
| Revision History | 2 | ESD Caution | 13 |
| Specifications | 3 | Pin Configurations and Function Descriptions..... | 14 |
| Electrical Characteristics—5 V Primary Input Supply/5 V | | Truth Table | 17 |
| Secondary Isolated Supply | 3 | Typical Performance Characteristics | 18 |
| Electrical Characteristics—5 V Primary Input Supply/3.3 V | | Terminology..... | 21 |
| Secondary Isolated Supply | 3 | Theory of Operation | 22 |
| Electrical Characteristics—3.3 V Primary Input Supply/3.3 V | | Applications Information | 23 |
| Secondary Isolated Supply | 4 | PCB Layout | 23 |
| Electrical Characteristics—5.0 V Operation Digital Isolator | | Thermal Analysis | 24 |
| Channels Only | 4 | Propagation Delay Related Parameters..... | 24 |
| Electrical Characteristics—3.3 V Operation Digital Isolator | | EMI Considerations..... | 24 |
| Channels Only | 6 | Power Consumption..... | 24 |
| Electrical Characteristics—2.5 V Operation Digital Isolator | | Insulation Lifetime..... | 24 |
| Channels Only | 8 | Outline Dimensions..... | 26 |
| Electrical Characteristics—1.8 V Operation Digital Isolator | | Ordering Guide | 26 |
| Channels Only | 9 | | |
| Package Characteristics | 11 | | |
| Regulatory Approvals | 11 | | |

REVISION HISTORY

12/2020—Rev. 0 to Rev. A

| | | | |
|---|---|--|----|
| Changes to Table 1 | 1 | Changes to Table 11 and Table 13 | 8 |
| Changes to Electrical Characteristics—5 V Primary Input | | Changes to Table 14..... | 9 |
| Supply/5 V Secondary Isolated Supply Section..... | 3 | Changes to Table 21 | 12 |
| Moved Electrical Characteristics—5 V Primary Input | | Changes to Table 23 | 13 |
| Supply/3.3 V Secondary Isolated Supply Section and Table 6; | | Change to Table 24 | 14 |
| Renumbered Sequentially | 3 | Change to Table 25 | 15 |
| Added Electrical Characteristics—3.3 V Primary Input | | Change to Table 26 | 16 |
| Supply/3.3 V Secondary Isolated Supply Section, Table 4, | | Changes to Table 28..... | 17 |
| Electrical Characteristics—5.0 V Operation Digital Isolator | | Changes to Figure 6, Figure 7, and Figure 8..... | 18 |
| Channels Only Section, and Table 5..... | 4 | Changes to PCB Layout Section, Figure 22, and Figure 23..... | 23 |
| Changes to Table 7 | 5 | Change to Thermal Analysis Section | 24 |
| Removed Table 7 and Table 8..... | 6 | Changes to Ordering Guide..... | 26 |
| Changes to Table 8 | 6 | | |
| Removed Table 9 | 7 | | |
| Changes to Table 10..... | 7 | | |

12/2019—Revision 0: Initial Version

SPECIFICATIONS

ELECTRICAL CHARACTERISTICS—5 V PRIMARY INPUT SUPPLY/5 V SECONDARY ISOLATED SUPPLY

All typical specifications are at $T_A = 25^\circ\text{C}$, $V_{DDP} = V_{ISO} = 5\text{ V}$. Minimum and maximum specifications apply over the entire recommended operation range, which is $4.5\text{ V} \leq (V_{DDP}, V_{ISO}) \leq 5.5\text{ V}$ and $-40^\circ\text{C} \leq T_A \leq +125^\circ\text{C}$, unless otherwise noted.

Table 2. DC-to-DC Converters Static Specifications

| Parameter | Symbol | Min | Typ | Max | Unit | Test Conditions/Comments |
|--|-------------------|------|-----|------|------------------|---|
| DC-TO-DC CONVERTERS SUPPLY | | | | | | |
| Setpoint | V_{ISO} | 4.75 | 5.0 | 5.25 | V | ISO current (I_{ISO}) = 10 mA |
| Line Regulation | $V_{ISO (LINE)}$ | | 20 | | mV/V | $I_{ISO} = 50\text{ mA}$, $V_{DD1} = 4.5\text{ V}$ to 5.5 V |
| Load Regulation | $V_{ISO (LOAD)}$ | | 1 | 5 | % | $I_{ISO} = 10\text{ mA}$ to 90 mA |
| Output Ripple | $V_{ISO (RIP)}$ | | 75 | | mV p-p | 20 MHz bandwidth, bulk output capacitance (C_{BO}) = $0.1\ \mu\text{F} 10\ \mu\text{F}$, $I_{ISO} = 90\text{ mA}$ |
| Output Noise | $V_{ISO (NOISE)}$ | | 200 | | mV p-p | $C_{BO} = 0.1\ \mu\text{F} 10\ \mu\text{F}$, $I_{ISO} = 90\text{ mA}$ |
| Switching Frequency | f_{OSC} | | 180 | | MHz | |
| Pulse-Width Modulation (PWM) Frequency | f_{PWM} | | 625 | | kHz | |
| Output Supply ¹ | $I_{ISO (MAX)}$ | 100 | | | mA | $4.5\text{ V} < V_{ISO} < 5.25\text{ V}$ |
| | | 50 | | | mA | $4.75\text{ V} < V_{ISO} < 5.25\text{ V}$ |
| Efficiency at $I_{ISO (MAX)}$ ¹ | | | 34 | | % | $I_{ISO} = 100\text{ mA}$, $T_A = 25^\circ\text{C}$ |
| V_{DD1} Supply Current | | | | | | |
| No V_{ISO} Load | $I_{DDP (Q)}$ | | 14 | 25 | mA | |
| Full V_{ISO} Load | $I_{DDP (MAX)}$ | | 310 | | mA | |
| Thermal Shutdown | | | | | | |
| Shutdown Temperature | | | 154 | | $^\circ\text{C}$ | |
| Thermal Hysteresis | | | 10 | | $^\circ\text{C}$ | |

¹ Maximum V_{ISO} output current is derated by $1.75\text{ mA}/^\circ\text{C}$ for $T_A > 85^\circ\text{C}$.

ELECTRICAL CHARACTERISTICS—5 V PRIMARY INPUT SUPPLY/3.3 V SECONDARY ISOLATED SUPPLY

All typical specifications are at $T_A = 25^\circ\text{C}$, $V_{DDP} = 5.0\text{ V}$, $V_{ISO} = 3.3\text{ V}$. Minimum and maximum specifications apply over the entire recommended operation range, which is $4.5\text{ V} \leq V_{DDP} \leq 5.5\text{ V}$, $3.0\text{ V} \leq V_{ISO} \leq 3.6\text{ V}$, and $-40^\circ\text{C} \leq T_A \leq +125^\circ\text{C}$, unless otherwise noted.

Table 3. DC-to-DC Converters Static Specifications

| Parameter | Symbol | Min | Typ | Max | Unit | Test Conditions/Comments |
|--|-------------------|-------|-----|-------|------------------|---|
| DC-TO-DC CONVERTERS SUPPLY | | | | | | |
| Setpoint | V_{ISO} | 3.135 | 3.3 | 3.465 | V | $I_{ISO} = 10\text{ mA}$ |
| Line Regulation | $V_{ISO (LINE)}$ | | 20 | | mV/V | $I_{ISO} = 50\text{ mA}$, $V_{DD1} = 3.0\text{ V}$ to 3.6 V |
| Load Regulation | $V_{ISO (LOAD)}$ | | 1 | 5 | % | $I_{ISO} = 10\text{ mA}$ to 90 mA |
| Output Ripple | $V_{ISO (RIP)}$ | | 50 | | mV p-p | 20 MHz bandwidth, $C_{BO} = 0.1\ \mu\text{F} 10\ \mu\text{F}$, $I_{ISO} = 90\text{ mA}$ |
| Output Noise | $V_{ISO (NOISE)}$ | | 130 | | mV p-p | $C_{BO} = 0.1\ \mu\text{F} 10\ \mu\text{F}$, $I_{ISO} = 90\text{ mA}$ |
| Switching Frequency | f_{OSC} | | 180 | | MHz | |
| Pulse-Width Modulation Frequency | f_{PWM} | | 625 | | kHz | |
| Output Supply ¹ | $I_{ISO (MAX)}$ | 100 | | | mA | $3.0\text{ V} < V_{ISO} < 3.4\text{ V}$ |
| | | 50 | | | mA | $3.135\text{ V} < V_{ISO} < 3.465\text{ V}$ |
| Efficiency at $I_{ISO (MAX)}$ ¹ | | | 34 | | % | $I_{ISO} = 100\text{ mA}$ |
| V_{DDP} Supply Current | | | | | | |
| No V_{ISO} Load | $I_{DDP (Q)}$ | | 14 | 20 | mA | |
| Full V_{ISO} Load | $I_{DDP (MAX)}$ | | 250 | | mA | |
| Thermal Shutdown | | | | | | |
| Shutdown Temperature | | | 154 | | $^\circ\text{C}$ | |
| Thermal Hysteresis | | | 10 | | $^\circ\text{C}$ | |

¹ Maximum V_{ISO} output current is derated by $1.75\text{ mA}/^\circ\text{C}$ for $T_A > 85^\circ\text{C}$.

ELECTRICAL CHARACTERISTICS—3.3 V PRIMARY INPUT SUPPLY/3.3 V SECONDARY ISOLATED SUPPLY

All typical specifications are at $T_A = 25^\circ\text{C}$, $V_{DDP} = V_{ISO} = 3.3\text{ V}$. Minimum and maximum specifications apply over the entire recommended operation range, which is $3.0\text{ V} \leq V_{DDP}$, $V_{ISO} \leq 3.6\text{ V}$, and $-40^\circ\text{C} \leq T_A \leq +125^\circ\text{C}$, unless otherwise noted.

Table 4. DC-to-DC Converters Static Specifications

| Parameter | Symbol | Min | Typ | Max | Unit | Test Conditions/Comments |
|---|------------------|-------|-----|-------|------------------|---|
| DC-TO-DC CONVERTERS SUPPLY | | | | | | |
| Setpoint | V_{ISO} | 3.135 | 3.3 | 3.465 | V | $I_{ISO} = 10\text{ mA}$ |
| Line Regulation | $V_{ISO(LINE)}$ | | 20 | | mV/V | $I_{ISO} = 30\text{ mA}$, $V_{DD1} = 3.0\text{ V to }3.6\text{ V}$ |
| Load Regulation | $V_{ISO(LOAD)}$ | | 1 | 5 | % | $I_{ISO} = 6\text{ mA to }54\text{ mA}$ |
| Output Ripple | $V_{ISO(RIP)}$ | | 50 | | mV p-p | 20 MHz bandwidth, $C_{BO} = 0.1\ \mu\text{F} 10\ \mu\text{F}$, $I_{ISO} = 60\text{ mA}$ |
| Output Noise | $V_{ISO(NOISE)}$ | | 130 | | mV p-p | $C_{BO} = 0.1\ \mu\text{F} 10\ \mu\text{F}$, $I_{ISO} = 60\text{ mA}$ |
| Switching Frequency | f_{OSC} | | 180 | | MHz | |
| Pulse-Width Modulation Frequency | f_{PWM} | | 625 | | kHz | |
| Output Supply ¹ | $I_{ISO(MAX)}$ | 60 | | | mA | $3.0\text{ V} < V_{ISO} < 3.465\text{ V}$ |
| | | 30 | | | mA | $3.135\text{ V} < V_{ISO} < 3.465\text{ V}$ |
| Efficiency at $I_{ISO(MAX)}$ ¹ | | | 34 | | % | $I_{ISO} = 60\text{ mA}$ |
| V_{DDP} Supply Current | | | | | | |
| No V_{ISO} Load | $I_{DDP(Q)}$ | | 14 | 20 | mA | |
| Full V_{ISO} Load | $I_{DDP(MAX)}$ | | 190 | | mA | |
| Thermal Shutdown | | | | | | |
| Shutdown Temperature | | | 154 | | $^\circ\text{C}$ | |
| Thermal Hysteresis | | | 10 | | $^\circ\text{C}$ | |

¹ Maximum V_{ISO} output current is derated by $2.0\text{ mA}/^\circ\text{C}$ for $T_A > 105^\circ\text{C}$.

ELECTRICAL CHARACTERISTICS—5.0 V OPERATION DIGITAL ISOLATOR CHANNELS ONLY

All typical specifications are at $T_A = 25^\circ\text{C}$, $V_{DD1} = V_{DD2} = 5.0\text{ V}$. Minimum and maximum specifications apply over the entire recommended operation range: $4.5\text{ V} \leq V_{DD1}$, $V_{DD2} \leq 5.5\text{ V}$, and $-40^\circ\text{C} \leq T_A \leq +125^\circ\text{C}$, unless otherwise noted. Switching specifications are tested with $C_L = 15\text{ pF}$ and CMOS signal levels, unless otherwise noted. Supply currents are specified with 50% duty cycle signals.

Table 5. Data Channel Supply Current Specifications

| Parameter | Symbol | 1 Mbps | | | 10 Mbps | | | 100 Mbps | | | Unit | Test Conditions/Comments |
|----------------|-----------|--------|-----|-----|---------|-----|-----|----------|------|-----|------|--------------------------|
| | | Min | Typ | Max | Min | Typ | Max | Min | Typ | Max | | |
| SUPPLY CURRENT | | | | | | | | | | | | |
| ADuM6420AXRNZ5 | I_{DD1} | 4.9 | 8.7 | | 5.5 | 9.5 | | 8.0 | 12.2 | | mA | $C_L = 0\text{ pF}$ |
| | I_{DD2} | 1.5 | 2.5 | | 2.3 | 3.6 | | 8.0 | 11.0 | | mA | |
| ADuM6420AXRNZ3 | I_{DD1} | 4.9 | 8.7 | | 5.5 | 9.5 | | 8.0 | 12.2 | | mA | |
| | I_{DD2} | 1.5 | 2.5 | | 2.3 | 3.6 | | 9.3 | 15.0 | | mA | |
| ADuM6421AXRNZ5 | I_{DD1} | 4.2 | 8.4 | | 4.5 | 8.5 | | 8.0 | 12.0 | | mA | |
| | I_{DD2} | 2.3 | 4.5 | | 2.8 | 5.7 | | 8.8 | 12.0 | | mA | |
| ADuM6421AXRNZ3 | I_{DD1} | 4.2 | 8.4 | | 4.5 | 8.5 | | 8.0 | 12.0 | | mA | |
| | I_{DD2} | 2.3 | 4.5 | | 2.8 | 5.7 | | 9.4 | 15.0 | | mA | |
| ADuM6422AXRNZ5 | I_{DD1} | 3.3 | 6.0 | | 3.9 | 6.2 | | 8.3 | 12.0 | | mA | |
| | I_{DD2} | 3.0 | 6.0 | | 4.0 | 6.5 | | 9.5 | 13.5 | | mA | |
| ADuM6422AXRNZ3 | I_{DD1} | 3.3 | 6.0 | | 3.9 | 6.2 | | 8.3 | 12.0 | | mA | |
| | I_{DD2} | 3.0 | 6.0 | | 4.0 | 6.5 | | 9.5 | 14.0 | | mA | |

Table 6. Switching Specifications

| Parameter | Symbol | Min | Typ | Max | Unit | Test Conditions/Comments |
|--------------------------|-----------------------|-----|-----|-----|--------|--|
| SWITCHING SPECIFICATIONS | | | | | | |
| Pulse Width | PW | 10 | | | ns | Within pulse width distortion (PWD) limit |
| Data Rate | | | | 100 | Mbps | Within PWD limit |
| Propagation Delay | t_{PHL} , t_{PLH} | 7.0 | 10 | 15 | ns | 50% input to 50% output |
| Pulse Width Distortion | PWD | | 1 | 5 | ns | $ t_{PLH} - t_{PHL} $ |
| Change vs. Temperature | | | 1.5 | | ps/°C | |
| Propagation Delay Skew | t_{PSK} | | | 8.0 | ns | Between any two units at the same temperature, voltage, and load |
| Channel Matching | | | | | | |
| Codirectional | t_{PSKCD} | | 1 | 5.0 | ns | |
| Opposing Direction | t_{PSKOD} | | 1 | 5.0 | ns | |
| Jitter | | | 816 | | ps p-p | |

Table 7. Input and Output Characteristics

| Parameter | Symbol | Min | Typ | Max | Unit | Test Conditions/Comments |
|----------------------------|--------------|----------------------|-----------------|----------------------|---------|---|
| DC SPECIFICATIONS | | | | | | |
| Input Threshold | | | | | | |
| Logic High | V_{IH} | $0.7 \times V_{DDx}$ | | | V | |
| Logic Low | V_{IL} | | | $0.3 \times V_{DDx}$ | V | |
| Output Voltage | | | | | | |
| Logic High | V_{OH} | $V_{DDx} - 0.2$ | V_{DDx} | | V | $I_{Ox}^1 = -20 \mu A$, $V_{Ix} = V_{IxH}^2$ |
| Logic Low | V_{OL} | $V_{DDx} - 0.5$ | $V_{DDx} - 0.2$ | | V | $I_{Ox}^1 = -3.2 \text{ mA}$, $V_{Ix} = V_{IxH}^2$ |
| Logic Low | V_{OL} | | 0.0 | 0.1 | V | $I_{Ox}^1 = 20 \mu A$, $V_{Ix} = V_{IxL}^3$ |
| Logic Low | V_{OL} | | 0.0 | 0.4 | V | $I_{Ox}^1 = 3.2 \text{ mA}$, $V_{Ix} = V_{IxL}^3$ |
| Undervoltage Lockout | UVLO | | | | | V_{DD1} , V_{DD2} , and V_{DDP} supply |
| Positive Going Threshold | V_{UV+} | | 1.6 | | V | |
| Negative Going Threshold | V_{UV-} | | 1.5 | | V | |
| Hysteresis | V_{UVH} | | 0.1 | | V | |
| Input Currents per Channel | I_I | -10 | +0.01 | +10 | μA | $0 \text{ V} \leq V_{Ix} \leq V_{DDx}$ |
| Quiescent Supply Current | | | | | | |
| ADuM6420A | | | | | | |
| $I_{DD1(Q)}$ | | | 0.37 | 1.2 | mA | $V_{Ix} = \text{Logic 0}$ |
| $I_{DD2(Q)}$ | | | 1.2 | 1.9 | mA | $V_{Ix} = \text{Logic 0}$ |
| $I_{DD1(Q)}$ | | | 9.5 | 16 | mA | $V_{Ix} = \text{Logic 1}$ |
| $I_{DD2(Q)}$ | | | 1.5 | 2.5 | mA | $V_{Ix} = \text{Logic 1}$ |
| ADuM6421A | | | | | | |
| $I_{DD1(Q)}$ | | | 0.5 | 1.4 | mA | $V_{Ix} = \text{Logic 0}$ |
| $I_{DD2(Q)}$ | | | 0.9 | 1.5 | mA | $V_{Ix} = \text{Logic 0}$ |
| $I_{DD1(Q)}$ | | | 7.5 | 14 | mA | $V_{Ix} = \text{Logic 1}$ |
| $I_{DD2(Q)}$ | | | 3.3 | 6.2 | mA | $V_{Ix} = \text{Logic 1}$ |
| ADuM6422A | | | | | | |
| $I_{DD1(Q)}$ | | | 0.7 | 1.2 | mA | $V_{Ix} = \text{Logic 0}$ |
| $I_{DD2(Q)}$ | | | 0.72 | 1.3 | mA | $V_{Ix} = \text{Logic 0}$ |
| $I_{DD1(Q)}$ | | | 5.4 | 9.5 | mA | $V_{Ix} = \text{Logic 1}$ |
| $I_{DD2(Q)}$ | | | 5.3 | 9.7 | mA | $V_{Ix} = \text{Logic 1}$ |
| Dynamic Supply Current | | | | | | |
| Input | $I_{DDI(D)}$ | | 0.01 | | mA/Mbps | Inputs switching, 50% duty cycle |
| Output | $I_{DDO(D)}$ | | 0.02 | | mA/Mbps | Inputs switching, 50% duty cycle |

| Parameter | Symbol | Min | Typ | Max | Unit | Test Conditions/Comments |
|---|-----------|-----|-----|-----|-------------|--|
| AC SPECIFICATIONS | | | | | | |
| Output Rise Time/Fall Time | t_R/t_F | | 2.5 | | ns | 10% to 90% |
| Common-Mode Transient Immunity ⁴ | $ CM_H $ | 75 | 100 | | kV/ μ s | $V_{IX} = V_{DD1}$ or V_{ISO} , common-mode voltage (V_{CM}) = 1000 V, transient magnitude = 800 V |
| | $ CM_L $ | 75 | 100 | | kV/ μ s | $V_{IX} = 0$ V, $V_{CM} = 1000$ V, transient magnitude = 800 V |

¹ I_{OX} is the Channel x output current, where x is A, B, C, or D.

² V_{IXH} is the input side logic high.

³ V_{IXL} is the input side logic low.

⁴ $|CM_H|$ is the maximum common-mode voltage slew rate that can be sustained while maintaining the voltage output (V_O) > 0.8 V_{DDx} . $|CM_L|$ is the maximum common-mode voltage slew rate that can be sustained while maintaining V_O > 0.8 V. The common-mode voltage slew rates apply to both the rising and falling common-mode voltage edges.

ELECTRICAL CHARACTERISTICS—3.3 V OPERATION DIGITAL ISOLATOR CHANNELS ONLY

All typical specifications are at $T_A = 25^\circ\text{C}$, $V_{DD1} = V_{DD2} = 3.3$ V. Minimum and maximum specifications apply over the entire recommended operation range: $3.0\text{ V} \leq V_{DD1} \leq 3.6\text{ V}$, $3.0\text{ V} \leq V_{DD2} \leq 3.6\text{ V}$, and $-40^\circ\text{C} \leq T_A \leq +125^\circ\text{C}$, unless otherwise noted. Switching specifications are tested with $C_L = 15$ pF and CMOS signal levels, unless otherwise noted. Supply currents are specified with 50% duty cycle signals.

Table 8. Data Channel Supply Current Specifications

| Parameter | Symbol | 1 Mbps | | | 10 Mbps | | | 100 Mbps | | | Unit | Test Conditions/Comments |
|----------------|-----------|--------|-----|-----|---------|-----|-----|----------|------|-----|------|--------------------------|
| | | Min | Typ | Max | Min | Typ | Max | Min | Typ | Max | | |
| SUPPLY CURRENT | | | | | | | | | | | | |
| ADuM6420AXRNZ5 | I_{DD1} | 4.8 | 8.5 | | 4.9 | 9.0 | | 7.0 | 11.0 | | mA | $C_L = 0$ pF |
| | I_{DD2} | 1.4 | 2.5 | | 2.1 | 3.4 | | 7.5 | 11 | | mA | |
| ADuM6420AXRNZ3 | I_{DD1} | 4.8 | 8.5 | | 4.9 | 9.0 | | 7.0 | 11.0 | | mA | |
| | I_{DD2} | 1.4 | 2.5 | | 2.1 | 3.4 | | 7.5 | 12.0 | | mA | |
| ADuM6421AXRNZ5 | I_{DD1} | 4.0 | 8.3 | | 4.3 | 8.4 | | 7.1 | 11.6 | | mA | |
| | I_{DD2} | 2.1 | 4.4 | | 2.7 | 5.6 | | 8.0 | 11.6 | | mA | |
| ADuM6421AXRNZ3 | I_{DD1} | 4.0 | 8.3 | | 4.3 | 8.4 | | 7.1 | 11.6 | | mA | |
| | I_{DD2} | 2.1 | 4.4 | | 2.7 | 5.6 | | 8.0 | 12.0 | | mA | |
| ADuM6422AXRNZ5 | I_{DD1} | 3.1 | 6.0 | | 3.6 | 6.2 | | 7.4 | 11.0 | | mA | |
| | I_{DD2} | 3.0 | 6.0 | | 3.7 | 6.2 | | 8.5 | 12.0 | | mA | |
| ADuM6422AXRNZ3 | I_{DD1} | 3.1 | 6.0 | | 3.6 | 6.0 | | 7.4 | 11.0 | | mA | |
| | I_{DD2} | 3.0 | 6.0 | | 3.7 | 6.2 | | 8.5 | 13.0 | | mA | |

Table 9. Switching Specifications

| Parameter | Symbol | Min | Typ | Max | Unit | Test Conditions/Comments |
|--------------------------|-----------------------|-----|-----|-----|----------------------|--|
| SWITCHING SPECIFICATIONS | | | | | | |
| Pulse Width | PW | 10 | | | ns | Within PWD limit |
| Data Rate | | | | 100 | Mbps | Within PWD limit |
| Propagation Delay | t_{PHL} , t_{PLH} | 7.0 | 10 | 16 | ns | 50% input to 50% output |
| Pulse Width Distortion | PWD | | 1.0 | 5.0 | ns | $ t_{PLH} - t_{PHL} $ |
| Change vs. Temperature | | | 1.5 | | ps/ $^\circ\text{C}$ | |
| Propagation Delay Skew | t_{PSK} | | | 8.0 | ns | Between any two units at the same temperature, voltage, and load |
| Channel Matching | | | | | | |
| Codirectional | t_{PSKCD} | | 1.0 | 5.0 | ns | |
| Opposing Direction | t_{PSKOD} | | 1.0 | 5.0 | ns | |
| Jitter | | | 816 | | ps p-p | |

Table 10. Input and Output Characteristics

| Parameter | Symbol | Min | Typ | Max | Unit | Test Conditions/Comments |
|---|--------------|----------------------|------------------|----------------------|-------------|--|
| DC SPECIFICATIONS | | | | | | |
| Input Threshold | | | | | | |
| Logic High | V_{IH} | $0.7 \times V_{DDx}$ | | | V | |
| Logic Low | V_{IL} | | | $0.3 \times V_{DDx}$ | V | |
| Output Voltage | | | | | | |
| Logic High | V_{OH} | $V_{DDx} - 0.2$ | V_{DDx} | | V | $I_{Ox}^1 = -20 \mu A, V_{Ix} = V_{IxH}^2$ |
| | | $V_{DDx} - 0.5$ | $V_{DDx1} - 0.2$ | | V | $I_{Ox}^1 = -3.2 \text{ mA}, V_{Ix} = V_{IxH}^2$ |
| Logic Low | V_{OL} | | 0.0 | 0.1 | V | $I_{Ox}^1 = 20 \mu A, V_{Ix} = V_{IxL}^3$ |
| | | | 0.0 | 0.4 | V | $I_{Ox}^1 = 3.2 \text{ mA}, V_{Ix} = V_{IxL}^3$ |
| Undervoltage Lockout | UVLO | | | | | $V_{DD1}, V_{DD2},$ and V_{DDP} supply |
| Positive Going Threshold | V_{UV+} | | 1.6 | | V | |
| Negative Going Threshold | V_{UV-} | | 1.5 | | V | |
| Hysteresis | V_{UVH} | | 0.1 | | V | |
| Input Currents per Channel | I_I | -10 | +0.01 | +10 | μA | $0 V \leq V_{Ix} \leq V_{DDx}$ |
| Quiescent Supply Current | | | | | | |
| ADuM6420A | | | | | | |
| | $I_{DD1(Q)}$ | | 0.34 | 1.2 | mA | $V_{Ix} = \text{Logic } 0$ |
| | $I_{DD2(Q)}$ | | 1.1 | 1.8 | mA | $V_{Ix} = \text{Logic } 0$ |
| | $I_{DD1(Q)}$ | | 9.5 | 16 | mA | $V_{Ix} = \text{Logic } 1$ |
| | $I_{DD2(Q)}$ | | 1.5 | 2.4 | mA | $V_{Ix} = \text{Logic } 1$ |
| ADuM6421A | | | | | | |
| | $I_{DD1(Q)}$ | | 0.48 | 1.1 | mA | $V_{Ix} = \text{Logic } 0$ |
| | $I_{DD2(Q)}$ | | 0.8 | 1.5 | mA | $V_{Ix} = \text{Logic } 0$ |
| | $I_{DD1(Q)}$ | | 7.4 | 13.5 | mA | $V_{Ix} = \text{Logic } 1$ |
| | $I_{DD2(Q)}$ | | 3.2 | 6.2 | mA | $V_{Ix} = \text{Logic } 1$ |
| ADuM6422A | | | | | | |
| | $I_{DD1(Q)}$ | | 0.65 | 1.2 | mA | $V_{Ix} = \text{Logic } 0$ |
| | $I_{DD2(Q)}$ | | 0.7 | 1.2 | mA | $V_{Ix} = \text{Logic } 0$ |
| | $I_{DD1(Q)}$ | | 5.3 | 9.5 | mA | $V_{Ix} = \text{Logic } 1$ |
| | $I_{DD2(Q)}$ | | 5.4 | 9.6 | mA | $V_{Ix} = \text{Logic } 1$ |
| Dynamic Supply Current | | | | | | |
| Dynamic Input | $I_{DDI(D)}$ | | 0.01 | | mA/Mbps | Inputs switching, 50% duty cycle |
| Dynamic Output | $I_{DDO(D)}$ | | 0.01 | | mA/Mbps | Inputs switching, 50% duty cycle |
| AC SPECIFICATIONS | | | | | | |
| Output Rise/Fall Time | t_R/t_F | | 2.5 | | ns | 10% to 90% |
| Common-Mode Transient Immunity ⁴ | $ CM_H $ | 75 | 100 | | kV/ μs | $V_{Ix} = V_{DD1}$ or $V_{ISO}, V_{CM} = 1000 \text{ V},$ transient magnitude = 800 V |
| | $ CM_L $ | 75 | 100 | | kV/ μs | $V_{Ix} = 0 \text{ V}, V_{CM} = 1000 \text{ V},$ transient magnitude = 800 V |

¹ I_{Ox} is the Channel x output current, where x is A, B, C, or D.² V_{IxH} is the input side logic high.³ V_{IxL} is the input side logic low.⁴ $|CM_H|$ is the maximum common-mode voltage slew rate that can be sustained while maintaining the voltage output (V_O) > 0.8 V_{DDx} . $|CM_L|$ is the maximum common-mode voltage slew rate that can be sustained while maintaining $V_O > 0.8 \text{ V}$. The common-mode voltage slew rates apply to both the rising and falling common-mode voltage edges.

ELECTRICAL CHARACTERISTICS—2.5 V OPERATION DIGITAL ISOLATOR CHANNELS ONLY

All typical specifications are at $T_A = 25^\circ\text{C}$, $V_{DD1} = V_{DD2} = 2.5\text{ V}$. Minimum and maximum specifications apply over the entire recommended operation range: $2.25\text{ V} \leq V_{DD1} \leq 2.75\text{ V}$, $2.25\text{ V} \leq V_{DD2} \leq 2.75\text{ V}$, and $-40^\circ\text{C} \leq T_A \leq +125^\circ\text{C}$, unless otherwise noted. Switching specifications are tested with $C_L = 15\text{ pF}$ and CMOS signal levels, unless otherwise noted. Supply currents are specified with 50% duty cycle signals.

Table 11. Data Channel Supply Current Specifications

| Parameter | Symbol | 1 Mbps | | | 10 Mbps | | | 100 Mbps | | | Unit | Test Conditions/Comments |
|------------------------------------|------------------|--------|-----|-----|---------|-----|-----|----------|------|-----|-----------------------------|--------------------------|
| | | Min | Typ | Max | Min | Typ | Max | Min | Typ | Max | | |
| SUPPLY CURRENT | | | | | | | | | | | | |
| ADuM6420AXRNZ5/ ADuM6420AXRNZ3 | I _{DD1} | 4.8 | 8.5 | | 4.8 | 9.0 | | 6.4 | 11.0 | | mA C _L = 0 pF | |
| | I _{DD2} | 1.4 | 2.3 | | 2.0 | 3.3 | | 6.5 | 9.5 | | | |
| ADuM6421AXRNZ5/ ADuM6421AXRNZ53 | I _{DD1} | 4.2 | 8.0 | | 4.4 | 8.2 | | 6.7 | 11.5 | | | |
| | I _{DD2} | 2.3 | 4.4 | | 2.4 | 5.4 | | 6.5 | 10.0 | | | |
| ADuM6422AXRNZ5/ ADuM6422AXRNZ3 | I _{DD1} | 3.0 | 6.0 | | 3.4 | 6.1 | | 6.4 | 9.5 | | | |
| | I _{DD2} | 3.0 | 6.0 | | 3.4 | 6.1 | | 6.4 | 9.5 | | | |

Table 12. Switching Specifications

| Parameter | Symbol | Min | Typ | Max | Unit | Test Conditions/Comments |
|--------------------------|-------------------------------------|-----|-----|-----|--------|--|
| SWITCHING SPECIFICATIONS | | | | | | |
| Pulse Width | PW | 10 | | | ns | Within PWD limit |
| Data Rate | | | | 100 | Mbps | Within PWD limit |
| Propagation Delay | t _{PHL} , t _{PLH} | 8.0 | 11 | 16 | ns | 50% input to 50% output |
| Pulse Width Distortion | PWD | | 1.0 | 5.0 | ns | t _{PLH} - t _{PHL} |
| Change vs. Temperature | | | 1.5 | | ps/°C | |
| Propagation Delay Skew | t _{PSK} | | | 8.0 | ns | Between any two units at the same temperature, voltage, and load |
| Channel Matching | | | | | | |
| Codirectional | t _{PSKCD} | | 1.0 | 5.0 | ns | |
| Opposing Direction | t _{PSKOD} | | 1.0 | 5.0 | ns | |
| Jitter | | | 816 | | ps p-p | |

Table 13. Input and Output Characteristics

| Parameter | Symbol | Min | Typ | Max | Unit | Test Conditions/Comments | |
|----------------------------|---------------------|------------------------|------------------------|-----|----------------------|---|---|
| DC SPECIFICATIONS | | | | | | | |
| Input Threshold | | | | | | | |
| Logic High | V _{IH} | $0.7 \times V_{DDx}$ | | | V | | |
| Logic Low | V _{IL} | | | | $0.3 \times V_{DDx}$ | V | |
| Output Voltage | | | | | | | |
| Logic High | V _{OH} | V _{DDx} - 0.2 | V _{DDx} | | V | I _{ox} ¹ = -20 μA, V _{ix} = V _{ixH} ² | |
| | | V _{DDx} - 0.5 | V _{DDx} - 0.2 | | V | I _{ox} ¹ = -3.2 mA, V _{ix} = V _{ixH} ² | |
| Logic Low | V _{OL} | 0.0 | | 0.1 | V | I _{ox} ¹ = 20 μA, V _{ix} = V _{ixL} ³ | |
| | | 0.0 | | 0.4 | V | I _{ox} ¹ = 3.2 mA, V _{ix} = V _{ixL} ³ | |
| Undervoltage Lockout | UVLO | | | | | V | V _{DD1} , V _{DD2} , and V _{DDP} supply |
| Positive Going Threshold | V _{UV+} | 1.6 | | | V | | |
| Negative Going Threshold | V _{UV-} | 1.5 | | | V | | |
| Hysteresis | V _{UVH} | 0.1 | | | V | | |
| Input Currents per Channel | I _I | -10 | +0.01 | +10 | μA | 0 V ≤ V _{ix} ≤ V _{DDx} | |
| Quiescent Supply Current | | | | | | | |
| ADuM6420A | | | | | | | |
| | I _{DD1(Q)} | 0.33 | | 1.0 | mA | V _{ix} = Logic 0 | |
| | I _{DD2(Q)} | 1.1 | | 1.7 | mA | V _{ix} = Logic 0 | |
| | I _{DD1(Q)} | 1.5 | | 2.2 | mA | V _{ix} = Logic 1 | |
| | I _{DD2(Q)} | 9.5 | | 16 | mA | V _{ix} = Logic 1 | |

| Parameter | Symbol | Min | Typ | Max | Unit | Test Conditions/Comments |
|---|--------------------------------|-----|------|------|---------|--|
| ADuM6421A | I _{DD1(Q)} | | 0.5 | 1.0 | mA | V _{ix} = Logic 0 |
| | I _{DD2(Q)} | | 0.9 | 1.5 | mA | V _{ix} = Logic 0 |
| | I _{DD1(Q)} | | 7.4 | 13.5 | mA | V _{ix} = Logic 1 |
| | I _{DD2(Q)} | | 3.2 | 6.2 | mA | V _{ix} = Logic 1 |
| ADuM6422A | I _{DD1(Q)} | | 0.55 | 1.2 | mA | V _{ix} = Logic 0 |
| | I _{DD2(Q)} | | 0.55 | 1.2 | mA | V _{ix} = Logic 0 |
| | I _{DD1(Q)} | | 5.3 | 9.5 | mA | V _{ix} = Logic 1 |
| | I _{DD2(Q)} | | 5.3 | 9.5 | mA | V _{ix} = Logic 1 |
| Dynamic Supply Current | | | | | | |
| Dynamic Input | I _{DDI(D)} | | 0.01 | | mA/Mbps | Inputs switching, 50% duty cycle |
| Dynamic Output | I _{DDO(D)} | | 0.01 | | mA/Mbps | Inputs switching, 50% duty cycle |
| AC SPECIFICATIONS | | | | | | |
| Output Rise/Fall Time | t _R /t _F | | 2.5 | | ns | 10% to 90% |
| Common-Mode Transient Immunity ⁴ | CM _H | 75 | 100 | | kV/μs | V _{ix} = V _{DD1} or V _{ISO} , V _{CM} = 1000 V, transient magnitude = 800 V |
| | CM _L | 75 | 100 | | kV/μs | V _{ix} = 0 V, V _{CM} = 1000 V, transient magnitude = 800 V |

¹ I_{ox} is the Channel x output current, where x means A, B, C, or D.

² V_{ixH} is the input side logic high.

³ V_{ixL} is the input side logic low.

⁴ |CM_H| is the maximum common-mode voltage slew rate that can be sustained while maintaining the voltage output (V_o) > 0.8 V_{DDx}. |CM_L| is the maximum common-mode voltage slew rate that can be sustained while maintaining V_o > 0.8 V. The common-mode voltage slew rates apply to both the rising and falling common-mode voltage edges.

ELECTRICAL CHARACTERISTICS—1.8 V OPERATION DIGITAL ISOLATOR CHANNELS ONLY

All typical specifications are at T_A = 25°C, V_{DD1} = V_{DD2} = 1.8 V. Minimum and maximum specifications apply over the entire recommended operation range: 1.7 V ≤ V_{DD1} ≤ 1.9 V, 1.7 V ≤ V_{DD2} ≤ 1.9 V, and -40°C ≤ T_A ≤ +125°C, unless otherwise noted. Switching specifications are tested with C_L = 15 pF and CMOS signal levels, unless otherwise noted. Supply currents are specified with 50% duty cycle signals.

Table 14. Data Channel Supply Current Specifications

| Parameter | Symbol | 1 Mbps | | | 10 Mbps | | | 100 Mbps | | | Unit | Test Conditions/Comments |
|-------------------------------|------------------|--------|-----|-----|---------|-----|-----|----------|------|-----|------|--------------------------|
| | | Min | Typ | Max | Min | Typ | Max | Min | Typ | Max | | |
| SUPPLY CURRENT | | | | | | | | | | | | C _L = 0 pF |
| ADuM6420AXRNZ5/ADuM6420AXRNZ3 | I _{DD1} | 4.3 | 8.5 | | 4.9 | 8.5 | | 6.4 | 10.6 | | mA | |
| | I _{DD2} | 1.3 | 2.3 | | 1.4 | 2.5 | | 6.4 | 9.0 | | mA | |
| ADuM6421AXRNZ5/ADuM6421AXRNZ3 | I _{DD1} | 4.1 | 8.0 | | 4.4 | 8.0 | | 6.7 | 11.5 | | mA | |
| | I _{DD2} | 2.3 | 4.4 | | 2.6 | 5.3 | | 6.5 | 9.5 | | mA | |
| ADuM6422AXRNZ5/ADuM6422AXRNZ3 | I _{DD1} | 3.0 | 6.0 | | 3.4 | 6.2 | | 6.2 | 9.0 | | mA | |
| | I _{DD2} | 3.0 | 6.0 | | 3.4 | 6.2 | | 6.0 | 9.0 | | mA | |

Table 15. Switching Specifications

| Parameter | Symbol | Min | Typ | Max | Unit | Test Conditions/Comments |
|--------------------------|-------------------------------------|-----|-----|-----|--------|--|
| SWITCHING SPECIFICATIONS | | | | | | |
| Pulse Width | PW | 10 | | | ns | Within PWD limit |
| Data Rate | | | | 100 | Mbps | Within PWD limit |
| Propagation Delay | t _{PHL} , t _{PLH} | 8.0 | 12 | 17 | ns | 50% input to 50% output |
| Pulse Width Distortion | PWD | | 1.0 | 5.0 | ns | t _{PLH} - t _{PHL} |
| Change vs. Temperature | | | 1.5 | | ps/°C | |
| Propagation Delay Skew | t _{PSK} | | | 8.0 | ns | Between any two units at the same temperature, voltage, and load |
| Channel Matching | | | | | | |
| Codirectional | t _{PSKCD} | | 1.0 | 5.0 | ns | |
| Opposing Direction | t _{PSKOD} | | 1.0 | 5.0 | ns | |
| Jitter | | | 816 | | ps p-p | |

Table 16. Input and Output Characteristics

| Parameter | Symbol | Min | Typ | Max | Unit | Test Conditions/Comments |
|---|--------------|------------------------------------|------------------------------|----------------------|-------------|--|
| DC SPECIFICATIONS | | | | | | |
| Input Threshold | | | | | | |
| Logic High | V_{IH} | $0.7 \times V_{DDx}$ | | | V | |
| Logic Low | V_{IL} | | | $0.3 \times V_{DDx}$ | V | |
| Output Voltages | | | | | | |
| Logic High | V_{OH} | $V_{DDx} - 0.1$ $V_{DDx} - 0.4$ | V_{DDx} $V_{DDx} - 0.2$ | | V V | $I_{Ox}^1 = -20 \mu A, V_{Ix} = V_{IxH}^2$ $I_{Ox}^1 = -3.2 \text{ mA}, V_{Ix} = V_{IxH}^2$ |
| Logic Low | V_{OL} | | 0.0 0.2 | 0.1 0.4 | V V | $I_{Ox}^1 = 20 \mu A, V_{Ix} = V_{Ixl}^3$ $I_{Ox}^1 = 3.2 \text{ mA}, V_{Ix} = V_{Ixl}^3$ |
| Undervoltage Lockout | UVLO | | | | | $V_{DD1}, V_{DD2},$ and V_{DDP} supply |
| Positive Going Threshold | V_{UV+} | | 1.6 | | V | |
| Negative Going Threshold | V_{UV-} | | 1.5 | | V | |
| Hysteresis | V_{UVH} | | 0.1 | | V | |
| Input Currents per Channel | I_i | -10 | +0.01 | +10 | μA | $0 \text{ V} \leq V_{Ix} \leq V_{DDx}$ |
| Quiescent Supply Current | | | | | | |
| ADuM6420A | | | | | | |
| | $I_{DD1(Q)}$ | | 0.35 | 1.0 | mA | $V_{Ix} = \text{Logic } 0$ |
| | $I_{DD2(Q)}$ | | 1.0 | 1.7 | mA | $V_{Ix} = \text{Logic } 0$ |
| | $I_{DD1(Q)}$ | | 9.4 | 16 | mA | $V_{Ix} = \text{Logic } 1$ |
| | $I_{DD2(Q)}$ | | 1.4 | 2.2 | mA | $V_{Ix} = \text{Logic } 1$ |
| ADuM6421A | | | | | | |
| | $I_{DD1(Q)}$ | | 0.5 | 1.0 | mA | $V_{Ix} = \text{Logic } 0$ |
| | $I_{DD2(Q)}$ | | 0.9 | 1.4 | mA | $V_{Ix} = \text{Logic } 0$ |
| | $I_{DD1(Q)}$ | | 7.5 | 13.5 | mA | $V_{Ix} = \text{Logic } 1$ |
| | $I_{DD2(Q)}$ | | 3.2 | 6.2 | mA | $V_{Ix} = \text{Logic } 1$ |
| ADuM6422A | | | | | | |
| | $I_{DD1(Q)}$ | | 0.6 | 1.2 | mA | $V_{Ix} = \text{Logic } 0$ |
| | $I_{DD2(Q)}$ | | 0.65 | 1.2 | mA | $V_{Ix} = \text{Logic } 0$ |
| | $I_{DD1(Q)}$ | | 5.3 | 9.5 | mA | $V_{Ix} = \text{Logic } 1$ |
| | $I_{DD2(Q)}$ | | 5.3 | 9.5 | mA | $V_{Ix} = \text{Logic } 1$ |
| Dynamic Supply Current | | | | | | |
| Input | $I_{DDI(D)}$ | | 0.01 | | mA/Mbps | Inputs switching, 50% duty cycle |
| Output | $I_{DDO(D)}$ | | 0.01 | | mA/Mbps | Inputs switching, 50% duty cycle |
| AC SPECIFICATIONS | | | | | | |
| Output Rise/Fall Time | t_R/t_F | | 2.5 | | ns | 10% to 90% |
| Common-Mode Transient Immunity ⁴ | $ CM_H $ | 75 | 100 | | kV/ μs | $V_{Ix} = V_{DD1}$ or $V_{ISO}, V_{CM} = 1000 \text{ V},$ transient magnitude = 800 V |
| | $ CM_L $ | 75 | 100 | | kV/ μs | $V_{Ix} = 0 \text{ V}, V_{CM} = 1000 \text{ V},$ transient magnitude = 800 V |

¹ I_{Ox} is the Channel x output current, where x means A, B, C, or D.² V_{IxH} is the input side logic high.³ V_{Ixl} is the input side logic low.⁴ $|CM_H|$ is the maximum common-mode voltage slew rate that can be sustained while maintaining the voltage output (V_O) > 0.8 V_{DDx} . $|CM_L|$ is the maximum common-mode voltage slew rate that can be sustained while maintaining $V_O > 0.8 \text{ V}$. The common-mode voltage slew rates apply to both the rising and falling common-mode voltage edges.

PACKAGE CHARACTERISTICS

Table 17. Thermal and Isolation Characteristics

| Parameter | Symbol | Min | Typ | Max | Unit | Test Conditions/Comments |
|--|------------------|-----|------------------|-----|------|--|
| Resistance (Input to Output) ¹ | R _{I-O} | | 10 ¹³ | | Ω | |
| Capacitance (Input to Output) ¹ | C _{I-O} | | 2.2 | | pF | Frequency = 1 MHz |
| Input Capacitance ² | C _I | | 4.0 | | pF | |
| IC Junction to Ambient Thermal Resistance | θ _{JA} | | 45 | | °C/W | Thermocouple located at center of package underside, test conducted on 4-layer board with thin traces ³ |

¹ The device is considered a 2-terminal device: Pin 1 to Pin 14 are shorted together, and Pin 15 to Pin 28 are shorted together.

² Input capacitance is from any input data pin to ground.

³ See the Thermal Analysis section for thermal model definitions.

REGULATORY APPROVALS

Table 18.

| UL (Pending) ¹ | CSA (Pending) | VDE (Pending) ² | CQC (Pending) |
|---|--|---|--|
| Recognized Under UL 1577 Component Recognition Program ¹ | Approved under CSA Component Acceptance Notice 5A | DIN V VDE V 0884-11 (VDE V 0884-11):2017-1 | Certified under CQC11-471543-2012 |
| Single Protection, 5000 V rms Isolation Voltage | CSA 60950-1-07+A1+A2 and IEC 60950-1, second edition, +A1+A2: Basic insulation at 830 V rms (1173 V peak) Reinforced insulation at 415 V rms (586 V peak) IEC 60601-1 Edition 3.1: Basic insulation (1 means of patient protection (1 MOPP)), 250 V rms CSA 61010-1-12 and IEC 61010-1 third edition: Basic insulation at 300 V rms mains, 815 V rms (1173 V peak) secondary Reinforced insulation at 300 V rms mains, 415 V rms (586 V peak) | Reinforced insulation 566 V peak, V _{IOSM} = 6000 V peak Transient voltage, V _{IOTM} = 8000 V peak | GB4943.1-2011: Basic insulation at 815 V rms (1173 V peak) Reinforced insulation at 415 V rms (586 V peak) |
| File E214100 | File 205078 | File (pending) | File (pending) |

¹ In accordance with UL 1577, each ADuM6420A/ADuM6421A/ADuM6422A is proof tested by applying an insulation test voltage ≥ 6000 V rms for 1 sec.

² In accordance with DIN V VDE V 0884-11, each ADuM6420A/ADuM6421A/ADuM6422A is proof tested by applying an insulation test voltage ≥ 1059 V peak for 1 sec (partial discharge detection limit = 5 pC). The * marking branded on the component designates DIN V VDE V 0884-11 approval.

INSULATION AND SAFETY RELATED SPECIFICATIONS

Table 19. Critical Safety Related Dimensions and Material Properties

| Parameter | Symbol | Value | Unit | Test Conditions/Comments |
|--|---------|-------|--------|--|
| Rated Dielectric Insulation Voltage | | 5000 | V rms | 1-minute duration |
| Minimum External Air Gap (Clearance) | L(I01) | 8.3 | mm min | Measured from input terminals to output terminals, shortest distance through air |
| Minimum External Tracking (Creepage) | L(I02) | 8.3 | mm min | Measured from input terminals to output terminals, shortest distance path along body |
| Minimum Clearance in the Plane of the PCB | L (PCB) | 8.3 | mm min | Measured from input terminals to output terminals, shortest distance through air, line of sight, in the PCB mounting plane |
| Minimum Internal Gap (Internal Clearance) | | 25.5 | μm min | Minimum distance through insulation |
| Tracking Resistance (Comparative Tracking Index) | CTI | >600 | V | DIN IEC 112/VDE 0303, Part 1 |
| Isolation Group | | I | | Material group (DIN VDE 0110, 1/89, Table 1) |

DIN V VDE V 0884-11 INSULATION CHARACTERISTICS

The ADuM6420A/ADuM6421A/ADuM6422A are suitable for reinforced electrical isolation only within the safety limit data. Maintenance of the safety data is ensured by the protective circuits. The asterisk (*) marking on packages denotes DIN V VDE V 0884-11 approval.

Table 20. VDE Characteristics

| Description | Test Conditions/Comments | Symbol | Characteristic | Unit |
|---|---|---------------------------------------|-------------------------------|--------|
| Installation Classification per DIN VDE 0110 For Rated Mains Voltage ≤ 150 V rms For Rated Mains Voltage ≤ 300 V rms For Rated Mains Voltage ≤ 400 V rms | | | I to IV I to IV I to IV | |
| Climatic Classification | | | 40/125/21 | |
| Pollution Degree per DIN VDE 0110, Table 1 | | | 2 | |
| Maximum Working Insulation Voltage | | V _{IORM} | 566 | V peak |
| Input to Output Test Voltage, Method b1 | V _{IORM} × 1.875 = V _{PR} , 100% production test, t _m = 1 sec, partial discharge < 5 pC | V _{PR} | 1059 | V peak |
| Input to Output Test Voltage, Method a After Environmental Tests Subgroup 1 | V _{IORM} × 1.5 = V _{pd(m)} , t _{ini} = 60 sec, t _m = 10 sec, partial discharge < 5 pC | V _{PR} V _{pd(m)} | 849 | V peak |
| After Input and/or Safety Test Subgroup 2 and Subgroup 3 | V _{IORM} × 1.2 = V _{pd(m)} , t _{ini} = 60 sec, t _m = 10 sec, partial discharge < 5 pC | V _{pd(m)} | 679 | V peak |
| Highest Allowable Overvoltage | Transient overvoltage, t _{TR} = 10 sec | V _{IOTM} | 8000 | V peak |
| Withstand Isolation Voltage | 1-minute withstand rating | V _{ISO} | 5000 | V rms |
| Surge Isolation Voltage Reinforced | V _{IOSM(TEST)} = 12.8 kV; 1.2 μs rise time; 50 μs, 50% fall time | V _{IOSM} | 8000 | V peak |
| Safety Limiting Values | Maximum value allowed in the event of a failure (see Figure 2) | | | |
| Case Temperature | | T _S | 150 | °C |
| Total Power Dissipation at 25°C | | I _{S1} | 2.78 | W |
| Insulation Resistance at T _S | V _{IO} = 500 V | R _S | >10 ⁹ | Ω |

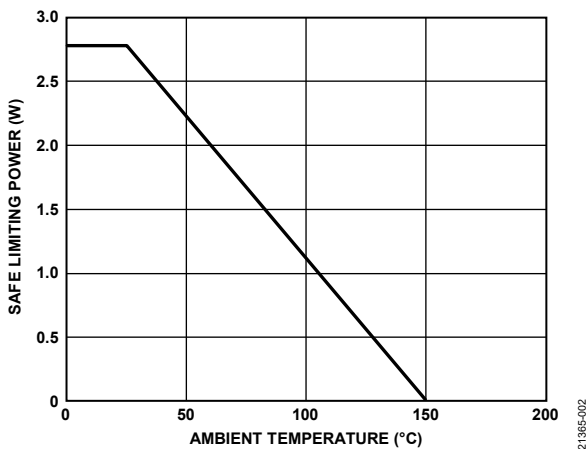

Figure 2. Thermal Derating Curve, Dependence of Safety Limiting Values on Case Temperature, per DIN EN 60747-5-2

RECOMMENDED OPERATING CONDITIONS

Table 21.

| Parameter | Min | Max | Unit |
|---|-----|------|------|
| Operating Temperature (T _A) ¹ | -40 | +125 | °C |
| Supply Voltages ² | | | |
| V _{DDP} at V _{SEL} = GND _{ISO} | 3.0 | 5.5 | V |
| V _{DDP} at V _{SEL} = V _{ISO} | 4.5 | 5.5 | V |
| V _{DD1} , V _{DD2} | 1.7 | 5.5 | V |

¹ Operation at >85°C requires reduction of the maximum load current.
² Each voltage is relative to its respective ground.

ABSOLUTE MAXIMUM RATINGS

$T_A = 25^\circ\text{C}$, unless otherwise noted.

Table 22.

| Parameter | Rating |
|---|--|
| Storage Temperature (T_{ST}) | -55°C to $+150^\circ\text{C}$ |
| Ambient Operating Temperature | -40°C to $+125^\circ\text{C}$ |
| Supply Voltages (V_{DD1} , V_{DDP} , V_{DD2} , V_{ISO}) ¹ | -0.5 V to $+7.0\text{ V}$ |
| V_{ISO} Supply Current ² | 100 mA |
| Input Voltage (V_{IA} , V_{IB} , V_{IC} , V_{ID} , V_{SEL} , $PDIS$) ^{1,3} | -0.5 V to $V_{DD1} + 0.5\text{ V}$ |
| Output Voltage (V_{OA} , V_{OB} , V_{OC} , V_{OD}) ^{1,3} | -0.5 V to $V_{DD0} + 0.5\text{ V}$ |
| Average Output Current Per Data Output Pin ⁴ | -10 mA to $+10\text{ mA}$ |
| Common-Mode Transients ⁵ | $-200\text{ kV}/\mu\text{s}$ to $+200\text{ kV}/\mu\text{s}$ |

¹ All voltages are relative to their respective ground.

² The V_{ISO} pin provides current for dc and dynamic loads on the V_{ISO} input and output channels. This current must be included when determining the total V_{ISO} supply current. For ambient temperatures between 85°C and 125°C , the maximum allowed current is reduced.

³ V_{DD1} and V_{DD0} refer to the supply voltages on the input and output sides of a given channel, respectively. See the PCB Layout section.

⁴ See Figure 2 for the maximum rated current values for various temperatures.

⁵ Common-mode transients refer to common-mode transients across the insulation barrier. Common-mode transients exceeding the absolute maximum ratings may cause latch-up or permanent damage.

Stresses at or above those listed under Absolute Maximum Ratings may cause permanent damage to the product. This is a stress rating only; functional operation of the product at these or any other conditions above those indicated in the operational section of this specification is not implied. Operation beyond the maximum operating conditions for extended periods may affect product reliability.

ESD CAUTION



ESD (electrostatic discharge) sensitive device. Charged devices and circuit boards can discharge without detection. Although this product features patented or proprietary protection circuitry, damage may occur on devices subjected to high energy ESD. Therefore, proper ESD precautions should be taken to avoid performance degradation or loss of functionality.

Table 23. Maximum Continuous Working Voltage¹

| Parameter | Rating | Constraint |
|-----------------------|-------------|--|
| AC Voltage | | |
| Bipolar Waveform | | |
| Basic Insulation | 636 V peak | |
| Reinforced Insulation | 566 V peak | |
| Unipolar Waveform | | |
| Basic Insulation | 733 V peak | |
| Reinforced Insulation | 652 V peak | |
| DC Voltage | | |
| Basic Insulation | 1158 V peak | Lifetime limited by package creepage per IEC 60664-1 |
| Reinforced Insulation | 579 V peak | Lifetime limited by package creepage per IEC 60664-1 |

¹ Maximum continuous working voltage refers to the continuous voltage magnitude imposed across the isolation barrier. See the Insulation Lifetime section for more information.

PIN CONFIGURATIONS AND FUNCTION DESCRIPTIONS

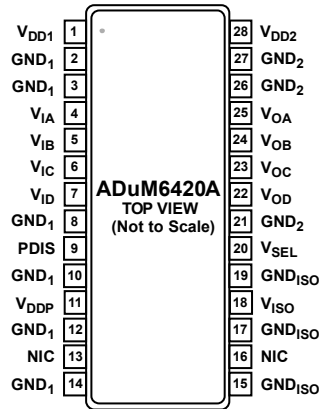

NOTES
1. NIC = NOT INTERNALLY CONNECTED. THESE PINS ARE NOT CONNECTED INTERNALLY.

21365-003

Figure 3. ADuM6420A Pin Configuration

Table 24. ADuM6420A Pin Function Descriptions

| Pin No. | Mnemonic | Description |
|---------------------|--------------------|--|
| 1 | V _{DD1} | Power Supply for the Side 1 Logic Circuits of the Device. V _{DD1} requires a 100 nF bypass capacitor. V _{DD1} is independent of V _{DDP} and can operate with power supply voltages between 1.7 V and 5.5 V. |
| 2, 3, 8, 10, 12, 14 | GND ₁ | Ground 1. Ground references for the primary isolator. Pin 2, Pin 3, Pin 8, Pin 10, Pin 12, and Pin 14 are internally connected, and it is recommended to connect the GND ₁ pins to a common ground. |
| 4 | V _{IA} | Logic Input A. |
| 5 | V _{IB} | Logic Input B. |
| 6 | V _{IC} | Logic Input C. |
| 7 | V _{ID} | Logic Input D. |
| 9 | PDIS | Power Disable. When PDIS is tied to GND ₁ , the power converter is active. When a logic high voltage is applied to PDIS, the power supply enters low power standby mode. |
| 11 | V _{DDP} | Primary Supply Voltage, 3.0 V to 5.5 V. V _{DDP} requires 100 nF and 10 μF bypass capacitors to GND ₁ . |
| 13, 16 | NIC | Not Internally Connected. These pins are not connected internally. |
| 15, 17, 19 | GND _{ISO} | Ground References for V _{ISO} on Side 2. It is recommended to connect the GND _{ISO} pins together. The GND _{ISO} pins are internally isolated from GND ₂ . |
| 18 | V _{ISO} | Secondary Supply Voltage Output for External Loads. Connect to V _{DD2} to power the isolator channels. |
| 20 | V _{SEL} | Output Voltage Select Input. Connect V _{SEL} to V _{ISO} for a 5 V output or to GND _{ISO} for a 3.3 V output. |
| 21, 26, 27 | GND ₂ | Ground References for V _{DD2} on Side 2. It is recommended that the GND ₂ pins be connected together. The GND ₂ pins are internally isolated from GND _{ISO} . |
| 22 | V _{OD} | Logic Output D. |
| 23 | V _{OC} | Logic Output C. |
| 24 | V _{OB} | Logic Output B. |
| 25 | V _{OA} | Logic Output A. |
| 28 | V _{DD2} | Power Supply for the Side 2 Logic Circuits of the Device. V _{DD2} requires a 100 nF bypass capacitor. V _{DD2} is independent of V _{ISO} and can operate with power supply voltages between 1.7 V and 5.5 V. |

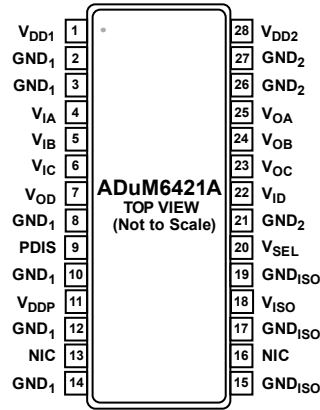

NOTES
1. NIC = NOT INTERNALLY CONNECTED. THESE PINS ARE NOT CONNECTED INTERNALLY.

21365-004

Figure 4. ADuM6421A Pin Configuration

Table 25. ADuM6421A Pin Function Descriptions

| Pin No. | Mnemonic | Description |
|---------------------|--------------------|--|
| 1 | V _{DD1} | Power Supply for the Side 1 Logic Circuits of the Device. V _{DD1} requires a 0.10 μF bypass capacitor to GND ₁ . V _{DD1} is independent of V _{DDP} and can operate with power supply voltages between 1.7 V and 5.5 V. |
| 2, 3, 8, 10, 12, 14 | GND ₁ | Ground 1. Ground references for the primary isolator. Pin 2, Pin 3, Pin 8, Pin 10, Pin 12, and Pin 14 are internally connected, and it is recommended to connect the GND ₁ pins to a common ground. |
| 4 | V _{IA} | Logic Input A. |
| 5 | V _{IB} | Logic Input B. |
| 6 | V _{IC} | Logic Input C. |
| 7 | V _{OD} | Logic Output D. |
| 9 | PDIS | Power Disable. When PDIS is tied to GND ₁ , the power converter is active. When a logic high voltage is applied to PDIS, the power supply enters low power standby mode. |
| 11 | V _{DDP} | DC-to-DC Converter Supply Voltage, 3.0 V to 5.5 V. V _{DDP} requires 0.10 μF and 10 μF bypass capacitors to GND ₁ . |
| 13, 16 | NIC | Not Internally Connected. These pins are not connected internally. |
| 15, 17, 19 | GND _{ISO} | Grounds for the Isolated DC-to-DC Converter. Connect the GND _{ISO} pins together through one ferrite bead to PCB ground. The GND _{ISO} pins are internally isolated from GND ₂ . |
| 18 | V _{ISO} | Secondary Supply Voltage Output for External Loads. V _{ISO} requires 0.10 μF and 10 μF capacitors to GND _{ISO} . Connect V _{ISO} through a ferrite bead to external loads. |
| 20 | V _{SEL} | Output Voltage Select Input. Connect V _{SEL} to V _{ISO} for a 5 V output or to GND _{ISO} for a 3.3 V output. |
| 21, 26, 27 | GND ₂ | Ground References for V _{DD2} on Side 2. It is recommended that the GND ₂ pins be connected together. The GND ₂ pins are internally isolated from GND _{ISO} . |
| 22 | V _{ID} | Logic Input D. |
| 23 | V _{OC} | Logic Output C. |
| 24 | V _{OB} | Logic Output B. |
| 25 | V _{OA} | Logic Output A. |
| 28 | V _{DD2} | Power Supply for the Side 2 Logic Circuits of the Device. V _{DD2} requires a 100 nF bypass capacitor. V _{DD2} is independent of V _{ISO} and can operate with power supply voltages between 1.7 V and 5.5 V. |

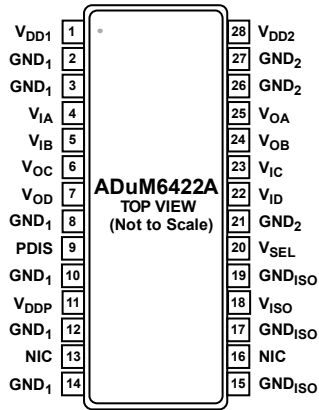

NOTES

1. NIC = NOT INTERNALLY CONNECTED. THESE PINS ARE NOT CONNECTED INTERNALLY.

21986-005

Figure 5. ADuM6422A Pin Configuration

Table 26. ADuM6422A Pin Function Descriptions

| Pin No. | Mnemonic | Description |
|---------------------|--------------------|--|
| 1 | V _{DD1} | Power Supply for the Side 1 Logic Circuits of the Device. V _{DD1} requires a 0.10 μF bypass capacitor to GND ₁ . V _{DD1} is independent of V _{DDP} and can operate with power supply voltages between 1.7 V and 5.5 V. |
| 2, 3, 8, 10, 12, 14 | GND ₁ | Ground 1. Ground references for the primary isolator. Pin 2, Pin 3, Pin 8, Pin 10, Pin 12, and Pin 14 are internally connected, and it is recommended to connect the GND ₁ pins to a common ground. |
| 4 | V _{IA} | Logic Input A. |
| 5 | V _{IB} | Logic Input B. |
| 6 | V _{OC} | Logic Output C. |
| 7 | V _{OD} | Logic Output D. |
| 9 | PDIS | Power Disable. When PDIS is tied to GND ₁ , the power converter is active. When a logic high voltage is applied to PDIS, the power supply enters a low power standby mode. |
| 11 | V _{DDP} | DC-to-DC Converter Supply Voltage, 3.0 V to 5.5 V. V _{DDP} requires 0.10 μF and 10 μF bypass capacitors to GND ₁ . |
| 13, 16 | NIC | Not Internally Connected. These pins are not connected internally. |
| 15, 17, 19 | GND _{ISO} | Grounds for the Isolated DC-to-DC Converter. Connect the GND _{ISO} pins together through one ferrite bead to PCB ground. The GND _{ISO} pins are internally isolated from GND ₂ . |
| 18 | V _{ISO} | Secondary Supply Voltage Output for External Loads. V _{ISO} requires 0.10 μF and 10 μF capacitors to GND _{ISO} . Connect V _{ISO} through a ferrite bead to external loads. |
| 20 | V _{SEL} | Output Voltage Select Input. Connect V _{SEL} to V _{ISO} for a 5 V output or to GND _{ISO} for a 3.3 V output. |
| 21, 26, 27 | GND ₂ | Ground Reference for V _{DD2} on Side 2. It is recommended that the GND ₂ pins be connected together. The GND ₂ pins are internally isolated from GND _{ISO} . |
| 22 | V _{ID} | Logic Input D. |
| 23 | V _{IC} | Logic Input C. |
| 24 | V _{OB} | Logic Output B. |
| 25 | V _{OA} | Logic Output A. |
| 28 | V _{DD2} | Power Supply for the Side 2 Logic Circuits of the Device. V _{DD2} requires a 100 nF bypass capacitor. V _{DD2} is independent of V _{ISO} and can operate with power supply voltages between 1.7 V and 5.5 V. |

TRUTH TABLE**Table 27. Data Section Truth Table (Positive Logic)**

| V_{DDI} State¹ | V_{IX} Input¹ | V_{DDO} State¹ | V_{Ox} Output¹ | Notes |
|--|---|--|--|--|
| Powered | High | Powered | High | Normal operation, data is high. |
| Powered | Low | Powered | Low | Normal operation, data is low. |
| Don't care | Don't care | Unpowered | High-Z | Output is off. |
| Unpowered | Low | Powered | Low | Output default low. |
| Unpowered | High | Powered | Indeterminate | If a high level is applied to an input when no supply is present, the input can parasitically power the input side, causing unpredictable operation. |

¹ V_{DDI} and V_{DDO} refer to the supply voltages on the input and output sides of the given channel, respectively. V_{IX} and V_{Ox} refer to the input and output signals of a given channel (Channel A, Channel B, Channel C, or Channel D).

Table 28. Power Section Truth Table (Positive Logic)

| V_{DDP} (V) | V_{SEL} Input | PDIS Input | V_{ISO} (V) |
|----------------------------|------------------------------|-------------------|----------------------------|
| 5 | High | Low | 5 |
| 5 | Don't care | High | 0 |
| 5 | Low | Low | 3.3 |
| 3.3 | Low | Low | 3.3 |
| 3.3 | High | Low | Condition not supported |
| 3.3 | Don't care | High | 0 |

TYPICAL PERFORMANCE CHARACTERISTICS

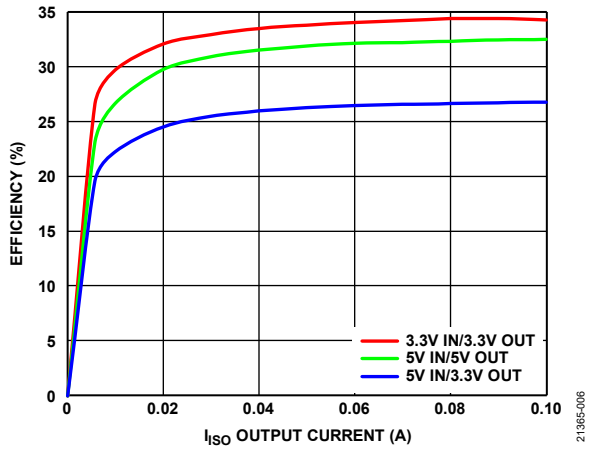

Figure 6. Power Supply Efficiency in Supported Power Configurations

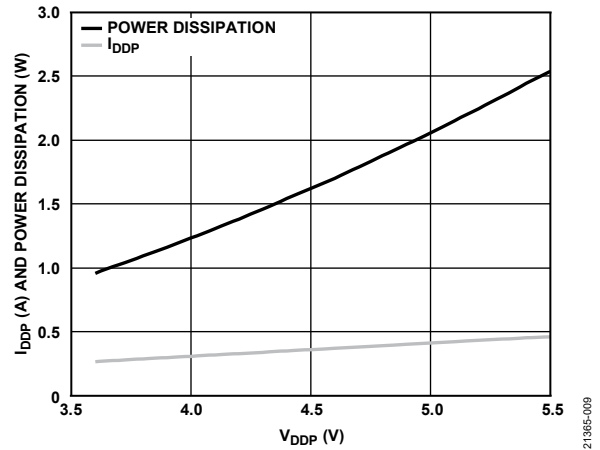

Figure 9. Short-Circuit Input Current (I_{DDP}) and Power Dissipation vs. V_{DDP}

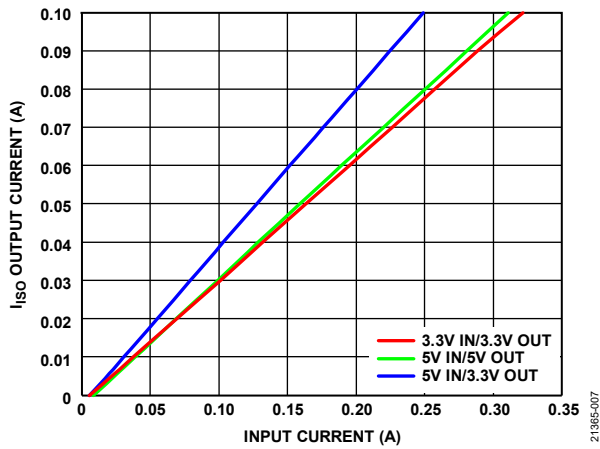

Figure 7. I_{ISO} Output Current vs. Input Current in Supported Power Configurations

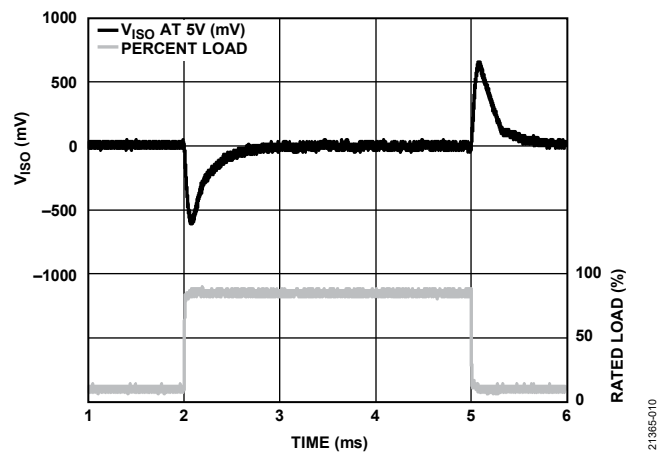

Figure 10. V_{ISO} Transient Load Response, 5 V Output, 10% to 90% Load Step

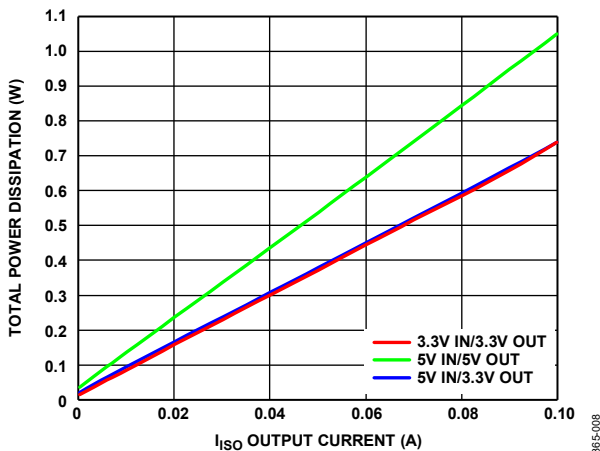

Figure 8. Total Power Dissipation vs. I_{ISO} Output Current in Supported Power Configurations

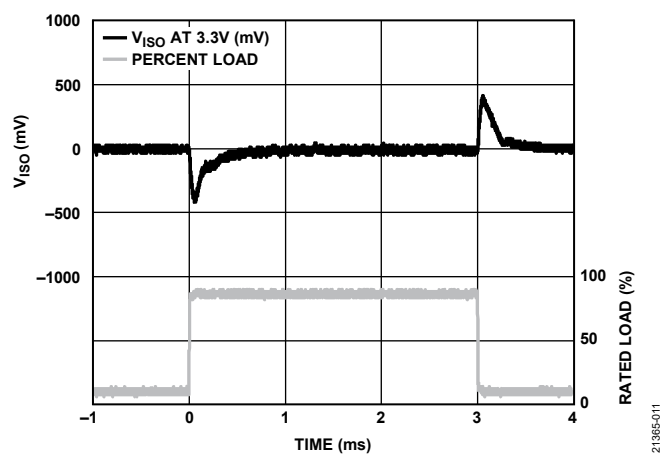

Figure 11. V_{ISO} Transient Load Response, 5 V Input, 3.3 V Output, 10% to 90% Load Step

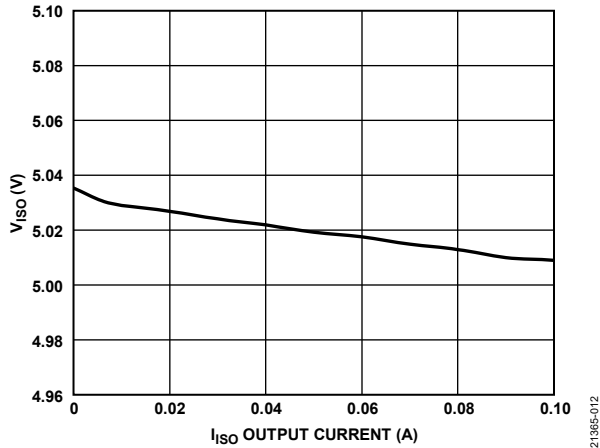

Figure 12. V_{ISO} vs. I_{ISO} Output Current, Input = 5 V, V_{ISO} = 5 V

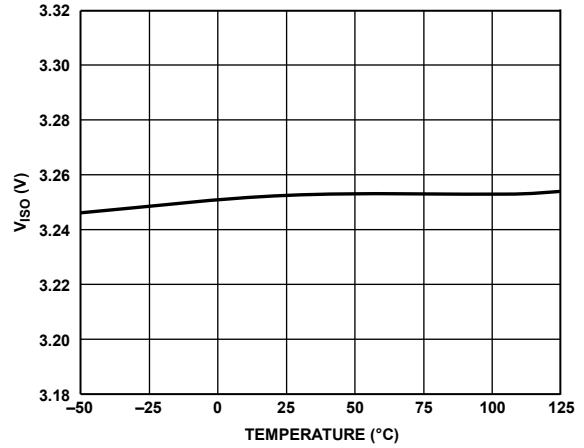

Figure 15. V_{ISO} vs. Temperature, Input = 3.3 V, V_{ISO} = 3.3 V

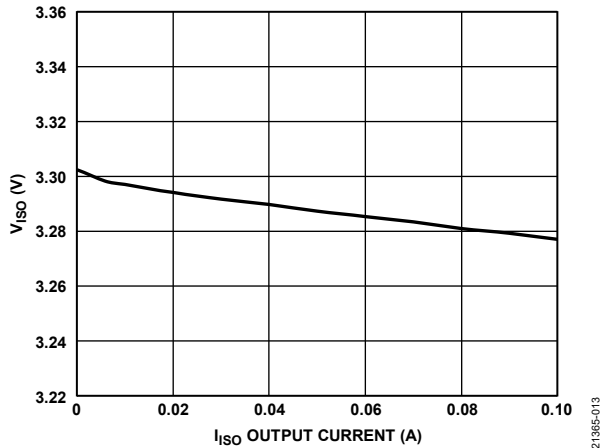

Figure 13. V_{ISO} vs. I_{ISO} Output Current, Input = 5 V, V_{ISO} = 3.3 V

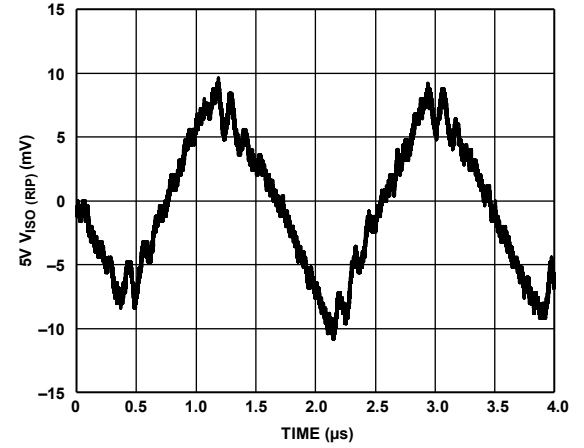

Figure 16. Output Voltage Ripple at 90% Load, V_{ISO} = 5 V

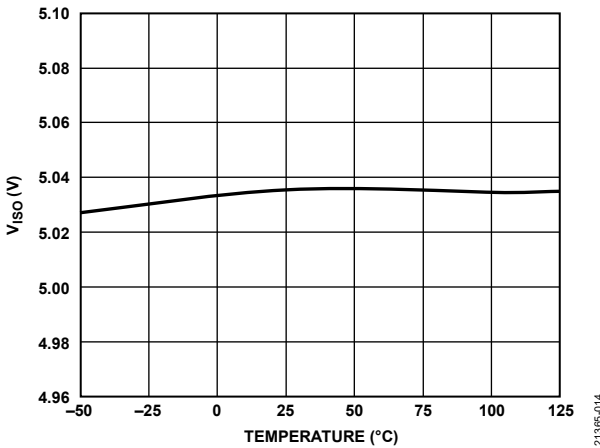

Figure 14. V_{ISO} vs. Temperature, Input = 5 V, V_{ISO} = 5 V

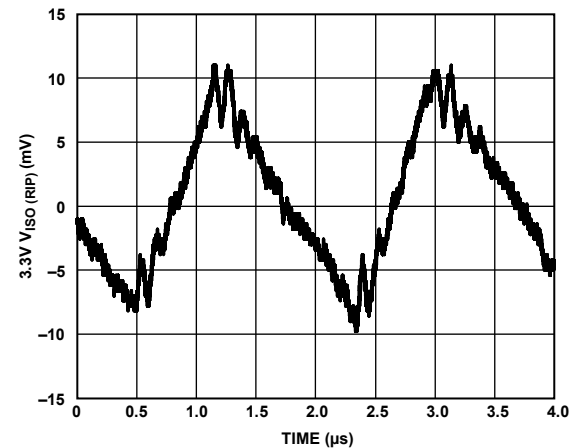

Figure 17. Output Voltage Ripple at 90% Load, V_{ISO} = 3.3 V

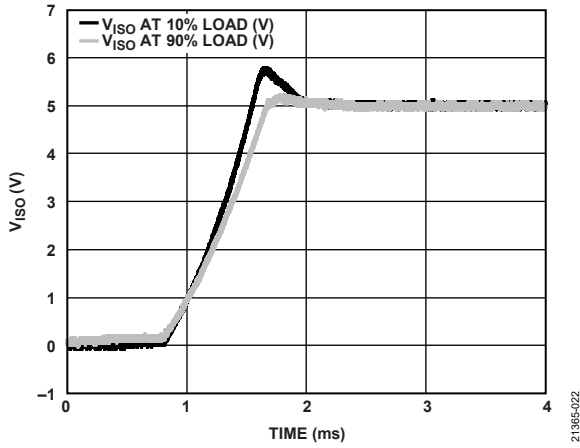

Figure 18. 5 V Input to 5 V Output V_{ISO} Start-Up Transient at 10% and 90% Load

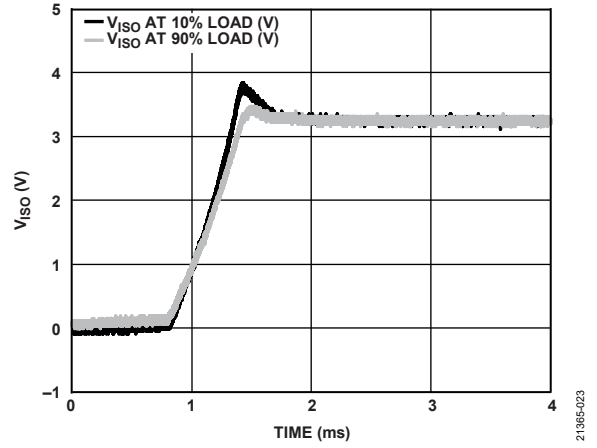

Figure 19. 5 V Input to 3.3 V Output V_{ISO} Start-Up Transient at 10% and 90% Load

TERMINOLOGY

I_{DD1}

I_{DD1} is the supply current required for the primary side of the digital isolator.

I_{DD2}

I_{DD2} is the supply current required for the secondary side of the digital isolator.

I_{DDP}

I_{DDP} is the supply current required for the primary side of the isolated dc-to-dc converter.

I_{ISO}

I_{ISO} is the available isolated current supply available to an external load.

Propagation Delay, t_{PHL}

t_{PHL} is measured from the 50% level of the falling edge of the V_{IX} signal to the 50% level of the falling edge of the V_{OX} signal.

Propagation Delay, t_{PLH}

t_{PLH} is measured from the 50% level of the rising edge of the V_{IX} signal to the 50% level of the rising edge of the V_{OX} signal.

Propagation Delay Skew, t_{PSK}

t_{PSK} is the magnitude of the worst-case difference in t_{PHL} and/or t_{PLH} that is measured between units at the same operating temperature, supply voltages, and output load within the recommended operating conditions.

Channel to Channel Matching, t_{PSKCD}/t_{PSKOD}

t_{PSKCD} is the absolute value of the difference in propagation delays between two codirectional channels when operated with identical loads. t_{PSKOD} is the absolute value of the difference in propagation delays between two channels transmitting in opposing directions.

Minimum Pulse Width

The minimum pulse width is the shortest pulse width at which the specified pulse width distortion is guaranteed.

Maximum Data Rate

The maximum data rate is the fastest data rate at which the specified pulse width distortion is guaranteed.

THEORY OF OPERATION

The dc-to-dc converter section of the ADuM6420A/ADuM6421A/ADuM6422A works on principles that are common to most modern power supplies. The ADuM6420A/ADuM6421A/ADuM6422A have a split controller architecture with isolated PWM feedback. V_{DDP} power is supplied to an oscillating circuit that switches current into a chip scale, air core transformer. Power transferred to the secondary side is rectified and regulated to a value of 3.3 V or 5 V, depending on the setting of the V_{SEL} pin. The secondary (V_{ISO}) side controller regulates the output by creating a PWM control signal that is sent to the primary (V_{DDP}) side by a dedicated *iCoupler* data channel. The PWM modulates the oscillator circuit to control the power being sent to the secondary side. Feedback allows for significantly higher power and efficiency.

The ADuM6420A/ADuM6421A/ADuM6422A implement undervoltage lockout (UVLO) with hysteresis on the primary and the secondary side input and output pins as well as the V_{DDP} power input. This feature ensures that the converter does not enter oscillation due to noisy input power or slow power-on ramp rates.

The digital isolator channels use a high frequency carrier to transmit data across the isolation barrier using *iCoupler* chip scale transformer coils separated by layers of polyimide isolation. Using an on/off keying technique and the differential architecture shown in Figure 20, the digital isolator channels have low propagation delay and high speed. Internal regulators and input and output design techniques allow logic and supply voltages over a wide range from 1.7 V to 5.5 V, offering voltage translation of 1.8 V, 2.5 V, 3.3 V, and 5 V logic. The architecture is designed for high common-mode transient immunity and high immunity to electrical noise and magnetic interference. Radiated emissions are minimized with a spread spectrum on/off keying carrier and other techniques.

Figure 20 shows the waveforms of the digital isolator channels that have the condition of the fail-safe output state equal to low, where the carrier waveform is off when the input state is low. If the input side is off or not operating, the low fail-safe output state sets the output to low.

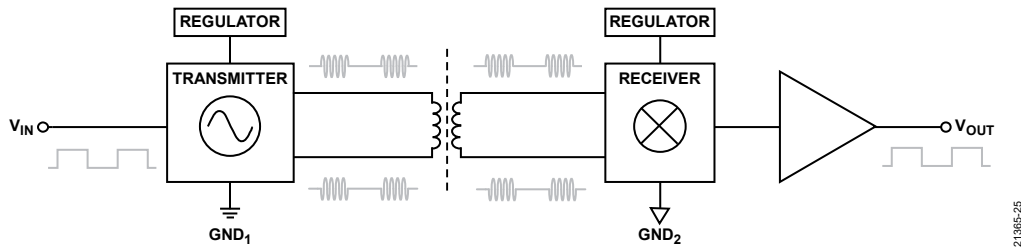

Figure 20. Operational Block Diagram of a Single Channel with a Low Fail-Safe Output State, V_{IN} Is the Input Voltage and V_{OUT} Is the Output Voltage

APPLICATIONS INFORMATION

PCB LAYOUT

The ADuM6420A/ADuM6421A/ADuM6422A digital isolators with an isoPower integrated dc-to-dc converter require no external interface circuitry for the logic interfaces. Power supply bypassing is required at the input and output supply pins (see Figure 21, Figure 22, and Figure 23). For proper data channel operation, low equivalent series resistance (ESR) bypass capacitors of 0.01 μF to 0.1 μF are required between the V_{DD1} pin and GND_1 pin as close to the chip pads as possible. Low ESR bypass capacitors of 0.1 μF or 0.22 μF are required between the V_{ISO} pin and GND_{ISO} pin as close to the chip pads as possible (see the C_{ISO} notes in Figure 22 and Figure 23). Installing the bypass capacitor with traces more than 2 mm in length may result in data corruption. The isoPower inputs require several passive components to bypass the power effectively, as well as set the output voltage.

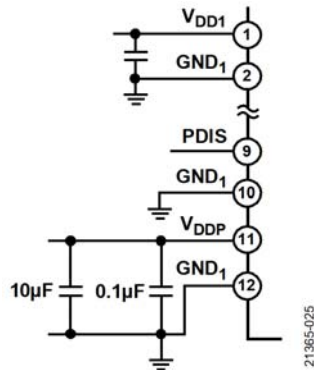

Figure 21. V_{DD1} and V_{DDP} Bias and Bypass Components

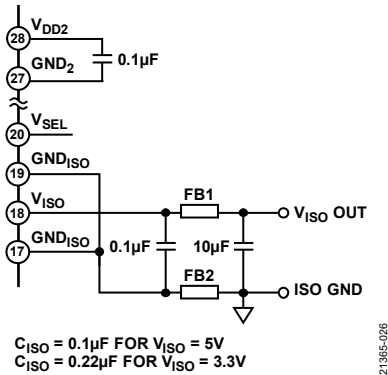

Figure 22. V_{DD2} and V_{ISO} Bias and Bypass Components

The power supply section of the ADuM6420A/ADuM6421A/ADuM6422A use a 180 MHz oscillator frequency to efficiently pass power through the chip scale transformers. Bypass capacitors are required for several operating frequencies. Noise suppression requires a low inductance, high frequency capacitor. Ripple suppression and proper regulation require a large value capacitor. These capacitors are connected between the V_{DDP} pin and GND_1 pin and between the V_{ISO} pin and GND_{ISO} pin. To suppress noise and reduce ripple, a parallel combination of at least two capacitors is required. The required capacitor values are 0.1 μF

and 10 μF for V_{DD1} . The smaller capacitor must have a low ESR. For example, use of a ceramic capacitor is advised. The total lead length between the ends of the low ESR capacitor and the input power supply pin must not exceed 2 mm.

To reduce the level of electromagnetic radiation, the impedance to high frequency currents between the V_{ISO} and the GND_{ISO} pins and the PCB trace connections can be increased. Using this method of electromagnetic interference (EMI) suppression controls the radiating signal at the signal source by placing surface-mount ferrite beads in series with the V_{ISO} and GND_{ISO} pins, as seen in Figure 23. The impedance of the ferrite bead must be approximately 1.8 k Ω between the 100 MHz and 1 GHz frequency range to reduce the emissions at the 180 MHz primary switching frequency and the 360 MHz secondary side, rectifying frequency and harmonics. See Table 29 for examples of appropriate surface-mount ferrite beads.

Table 29. Surface-Mount Ferrite Beads Example

| Manufacturer | Part No. |
|--------------------|----------------|
| Taiyo Yuden | BKH1005LM182-T |
| Murata Electronics | BLM15HD182SN1 |

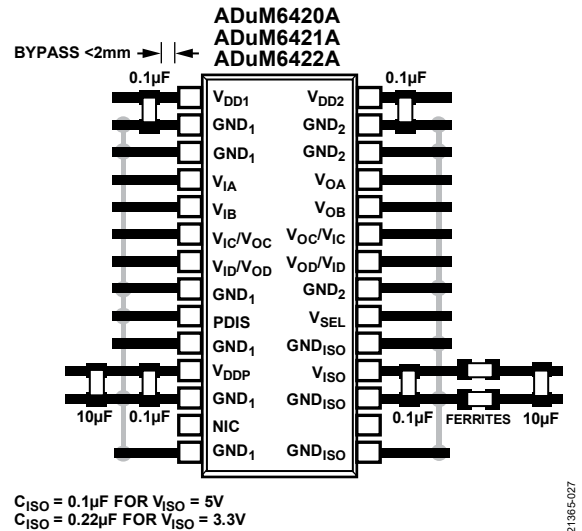

Figure 23. Recommended PCB Layout

In applications involving high common-mode transients, ensure that board coupling across the isolation barrier is minimized. Furthermore, design the board layout such that any coupling that does occur equally affects all pins on a given component side. Failure to ensure these steps can cause voltage differentials between pins, exceeding the absolute maximum ratings specified in Table 22, thereby leading to latch-up and/or permanent damage.

THERMAL ANALYSIS

The ADuM6420A/ADuM6421A/ADuM6422A consist of five internal die attached to a split lead frame with two die attach pads. For the purposes of thermal analysis, the die is treated as a thermal unit, with the highest junction temperature reflected in the θ_{JA} value from Table 17. The value of θ_{JA} is based on measurements taken with the devices mounted on a JEDEC standard, 4-layer board with fine width traces and still air. Under normal operating conditions, the ADuM6420A/ADuM6421A/ADuM6422A can operate at full load. However, at temperatures above 85°C, derating the output current may be needed, as shown in Figure 2.

PROPAGATION DELAY RELATED PARAMETERS

Propagation delay is a parameter that describes the time it takes a logic signal to propagate through a component (see Figure 24). The propagation delay to a logic low output may differ from the propagation delay to a logic high.

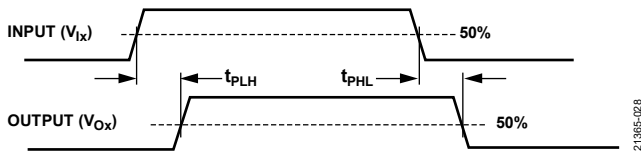

Figure 24. Propagation Delay Parameters

Pulse width distortion is the maximum difference between these two propagation delay values and is an indication of how accurately the input signal timing is preserved.

Channel to channel matching refers to the maximum amount the propagation delay differs between channels within a single ADuM6420A/ADuM6421A/ADuM6422A component.

Propagation delay skew refers to the maximum amount the propagation delay differs between multiple ADuM6420A/ADuM6421A/ADuM6422A components operating under the same conditions.

EMI CONSIDERATIONS

The dc-to-dc converter section of the ADuM6420A/ADuM6421A/ADuM6422A components must, of necessity, operate at a high frequency to allow efficient power transfer through the small transformers, which creates high frequency currents that can propagate in circuit board ground and power planes, requiring proper power supply bypassing at the input and output supply pins (see Figure 23). Using proper layout and bypassing techniques, the dc-to-dc converter is designed to provide regulated, isolated power that is below CISPR 32/EN 55032 Class B limits up to 5 Mbps at full load on a 2-layer PCB with ferrites.

POWER CONSUMPTION

The V_{DDP} power supply input only provides power to the converter. Power for the data channels is provided through V_{DD1} and V_{DD2} . These power supplies can be connected to V_{DDP} and V_{ISO} if desired, or the supplies can receive power from an independent source. Treat the converter as a standalone supply to be utilized at the discretion of the designer.

The V_{DD1} or V_{DD2} supply current at a given channel of the ADuM6420A/ADuM6421A/ADuM6422A isolators is a function of the supply voltage, the data rate of the channel, and the output load of the channel.

The V_{DD1} and V_{DD2} supply current and the total supply currents as a function of data rate for each model of the ADuM6420A/ADuM6421A/ADuM6422A for an unloaded output condition are shown under typical supply and room temperature conditions in the figures in the Typical Performance Characteristics section. The total I_{ISO} output current as a function of input current for the ADuM6420A/ADuM6421A/ADuM6422A is shown in Figure 7. In addition, the total power dissipation as a function of output current is shown in Figure 8.

INSULATION LIFETIME

All insulation structures eventually break down when subjected to voltage stress over a sufficiently long period. The rate of insulation degradation is dependent on the characteristics of the voltage waveform applied across the insulation as well as on the materials and material interfaces.

The two types of insulation degradation of primary interest are breakdown along surfaces exposed to the air and insulation wear out. Surface breakdown is the phenomenon of surface tracking and the primary determinant of surface creepage requirements in system level standards. Insulation wear out is the phenomenon where charge injection or displacement currents inside the insulation material cause long-term insulation degradation.

Surface Tracking

Surface tracking is addressed in electrical safety standards by setting a minimum surface creepage based on the working voltage, the environmental conditions, and the properties of the insulation material. Safety agencies perform characterization testing on the surface insulation of components that allows the components to be categorized in different material groups. Lower material group ratings are more resistant to surface tracking and, therefore, can provide adequate lifetime with smaller creepage. The minimum creepage for a given working voltage and material group is in each system level standard and is based on the total rms voltage across the isolation, pollution degree, and material group. The material group and creepage for the digital isolator channels are presented in Table 19.

Insulation Wear Out

The lifetime of insulation caused by wear out is determined by its thickness, material properties, and the voltage stress applied. It is important to verify that the product lifetime is adequate at the application working voltage. The working voltage supported by an isolator for wear out may not be the same as the working voltage supported for tracking. The working voltage applicable to tracking is specified in most standards.

Testing and modeling show that the primary driver of long-term degradation is displacement current in the polyimide insulation causing incremental damage. The stress on the insulation can be broken down into broad categories, such as dc stress, which causes little wear out because there is no displacement current, and an ac component time varying voltage stress, which causes wear out.

The ratings in certification documents are usually based on 60 Hz sinusoidal stress because this reflects isolation from line voltage. However, many practical applications have combinations of 60 Hz ac and dc across the barrier as shown in Equation 1. Because only the ac portion of the stress causes wear out, the equation can be rearranged to solve for the ac rms voltage, as shown in Equation 2. For insulation wear out with the polyimide materials used in these products, the ac rms voltage determines the product lifetime.

$$V_{RMS} = \sqrt{V_{AC\ RMS}^2 + V_{DC}^2} \tag{1}$$

or

$$V_{AC\ RMS} = \sqrt{V_{RMS}^2 - V_{DC}^2} \tag{2}$$

where:

V_{RMS} is the total rms working voltage.

$V_{AC\ RMS}$ is the time varying portion of the working voltage.

V_{DC} is the dc offset of the working voltage.

Calculation and Use of Parameters Example

The following example frequently arises in power conversion applications. Assume that the line voltage on one side of the isolation is 240 V ac rms and a 400 V dc bus voltage is present on the other side of the isolation barrier. The isolator material is polyimide. To establish the critical voltages in determining the creepage, clearance and lifetime of a device, see Figure 25 and the following equations.

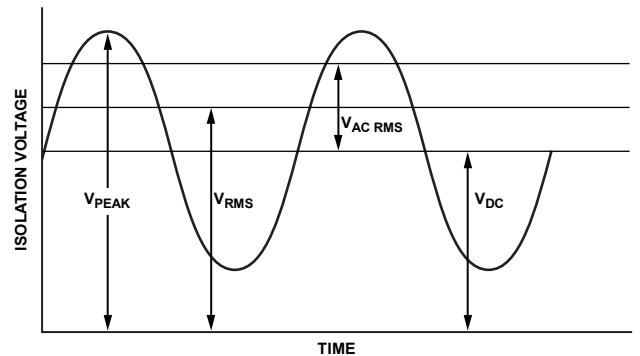

Figure 25. Critical Voltage Example

21365-028

The working voltage across the barrier from Equation 1 is

$$V_{RMS} = \sqrt{V_{AC\ RMS}^2 + V_{DC}^2}$$

$$V_{RMS} = \sqrt{240^2 + 400^2}$$

$$V_{RMS} = 466\text{ V}$$

This V_{RMS} value is the working voltage used together with the material group and pollution degree when looking up the creepage required by a system standard.

To determine if the lifetime is adequate, obtain the time varying portion of the working voltage. To obtain the ac rms voltage, use Equation 2.

$$V_{AC\ RMS} = \sqrt{V_{RMS}^2 - V_{DC}^2}$$

$$V_{AC\ RMS} = \sqrt{466^2 - 400^2}$$

$$V_{AC\ RMS} = 240\text{ V rms}$$

In this case, the ac rms voltage is simply the line voltage of 240 V rms. This calculation is more relevant when the waveform is not sinusoidal. The value is compared to the limits for working voltage in Table 23 for the expected lifetime, which is less than a 60 Hz sine wave, and it is well within the limit for a 50-year service life.

Note that the dc working voltage limit is set by the creepage of the package as specified in IEC 60664-1. This value can differ for specific system level standards.

OUTLINE DIMENSIONS

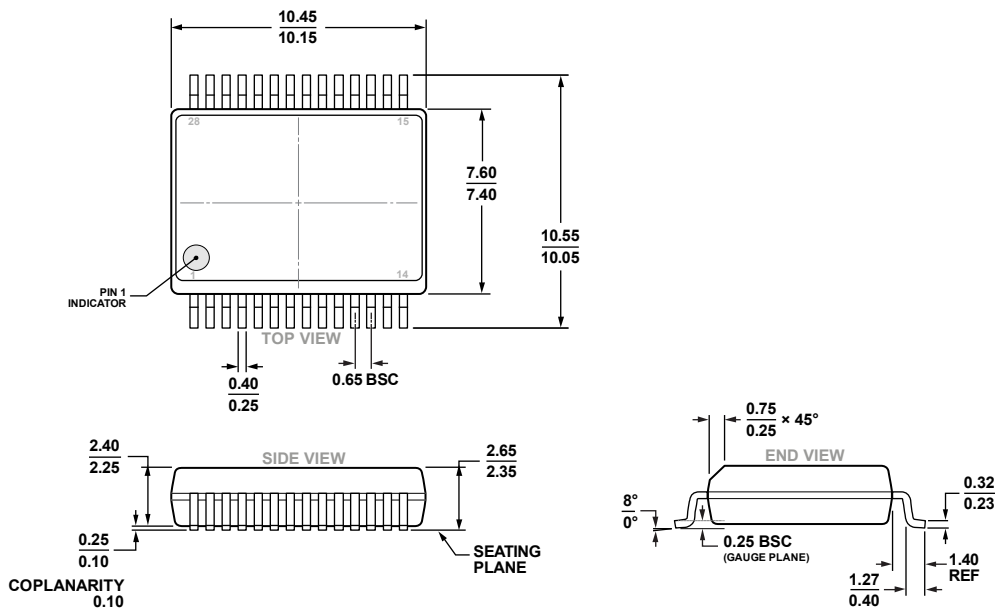

Figure 26. 28-Lead Standard Small Outline, Wide Body, with Finer Pitch [SOIC_W_FP] (RN-28-1)
Dimensions shown in millimeters

ORDERING GUIDE

| Model ^{1, 2, 3} | Number of Inputs, V _{DD1} Side | Number of Inputs, V _{ISO} Side | Standard or SPI Isolator | Typical V _{DDP} Voltage (V) | Temperature Range (°C) | Package Description | Package Option |
|--------------------------|---|---|--------------------------|--------------------------------------|------------------------|-------------------------------|----------------|
| ADuM6420ABRNZ5 | 4 | 0 | Standard | 5.0 | -40°C to +125°C | 28-Lead SOIC_W_FP | RN-28-1 |
| ADuM6420ABRNZ5-RL | 4 | 0 | Standard | 5.0 | -40°C to +125°C | 28-Lead SOIC_W_FP | RN-28-1 |
| ADuM6421ABRNZ5 | 3 | 1 | Standard | 5.0 | -40°C to +125°C | 28-Lead SOIC_W_FP | RN-28-1 |
| ADuM6421ABRNZ5-RL | 3 | 1 | Standard | 5.0 | -40°C to +125°C | 28-Lead SOIC_W_FP | RN-28-1 |
| ADuM6422ABRNZ5 | 2 | 2 | Standard | 5.0 | -40°C to +125°C | 28-Lead SOIC_W_FP | RN-28-1 |
| ADuM6422ABRNZ5-RL | 2 | 2 | Standard | 5.0 | -40°C to +125°C | 28-Lead SOIC_W_FP | RN-28-1 |
| ADuM6420ABRNZ3 | 4 | 0 | Standard | 3.3 | -40°C to +125°C | 28-Lead SOIC_W_FP | RN-28-1 |
| ADuM6420ABRNZ3-RL | 4 | 0 | Standard | 3.3 | -40°C to +125°C | 28-Lead SOIC_W_FP | RN-28-1 |
| ADuM6421ABRNZ3 | 3 | 1 | Standard | 3.3 | -40°C to +125°C | 28-Lead SOIC_W_FP | RN-28-1 |
| ADuM6421ABRNZ3-RL | 3 | 1 | Standard | 3.3 | -40°C to +125°C | 28-Lead SOIC_W_FP | RN-28-1 |
| ADuM6422ABRNZ3 | 2 | 2 | Standard | 3.3 | -40°C to +125°C | 28-Lead SOIC_W_FP | RN-28-1 |
| ADuM6422ABRNZ3-RL | 2 | 2 | Standard | 3.3 | -40°C to +125°C | 28-Lead SOIC_W_FP | RN-28-1 |
| EVAL-ADuM6421ARNZ | | | | | | Evaluation Board ² | |
| EVAL-ADuM6421AURNZ | | | | | | Evaluation Board ³ | |

¹ Z = RoHS Compliant Part.

² The EVAL-ADuM6421ARNZ is packaged with the ADuM6421ABRNZ5 installed.

³ The EVAL-ADuM6421AURNZ is packaged without a device installed. The ADuM6420A, ADuM6421A, or ADuM6422A must be ordered separately and installed.

X-ON Electronics

Largest Supplier of Electrical and Electronic Components

Click to view similar products for [Switching Voltage Regulators](#) category:

Click to view products by [Analog Devices](#) manufacturer:

Other Similar products are found below :

[FAN53610AUC33X](#) [FAN53611AUC123X](#) [FAN48610BUC33X](#) [FAN48610BUC45X](#) [FAN48617UC50X](#) [R3](#) [430464BB](#) [KE177614](#)
[FAN53611AUC12X](#) [MAX809TTR](#) [NCV891234MW50R2G](#) [NCP81103MNTXG](#) [NCP81203PMNTXG](#) [NCP81208MNTXG](#)
[NCP81109GMNTXG](#) [SCY1751FCCT1G](#) [NCP81109JMNTXG](#) [AP3409ADNTR-G1](#) [NCP81241MNTXG](#) [LTM8064IY](#) [LT8315EFE#TRPBF](#)
[LTM4664EY#PBF](#) [LTM4668AIY#PBF](#) [NCV1077CSTBT3G](#) [XCL207A123CR-G](#) [MPM54304GMN-0002](#) [MPM54304GMN-0004](#)
[MPM54304GMN-0003](#) [AP62300Z6-7](#) [MP8757GL-P](#) [MIC23356YFT-TR](#) [LD8116CGL](#) [HG2269M/TR](#) [OB2269](#) [XD3526](#) [U6215A](#) [U6215B](#)
[U6620S](#) [LTC3412IFE](#) [LT1425IS](#) [MAX25203BATJA/VY+](#) [MAX77874CEWM+](#) [XC9236D08CER-G](#) [MP3416GJ-P](#) [BD9S201NUX-CE2](#)
[MP5461GC-Z](#) [MPQ4415AGQB-Z](#) [MPQ4590GS-Z](#) [MAX38640BENT18+T](#) [MAX77511AEWB+](#)