

ADV611/ADV612

FEATURES

- Programmable "Quality Box"
- Industrial Temperature Range (ADV612)
- Hardware Frame Rate Reduction
- 100% Bitstream Compatible with the ADV601 and ADV601LC
- Precise Compressed Bit Rate Control
- Field Independent Compression
- 8-Bit Video Interface Supports CCIR-656 and Multiplexed Philips Formats
- General Purpose 16- or 32-Bit Host Interface with 512 Deep 32-Bit FIFO

PERFORMANCE

Real-Time Compression or Decompression of CCIR-601 to Video:

720 × 288 @ 50 Fields/Sec — PAL

720 × 243 @ 60 Fields/Sec — NTSC

Compression Ratios from Visually Loss-Less to 7500:1

Visually Loss-Less Compression At 4:1 on Natural Images (Typical)

APPLICATIONS

- CCTV Cameras and Systems
- Time-Lapse Video Tape Recorders
- Time-Lapse Video Disk Recorders
- Wireless CCTV Cameras
- Fiber CCTV Systems

GENERAL DESCRIPTION

The ADV611/ADV612 are low cost, single chip, dedicated function, all-digital-CMOS-VLSI devices capable of supporting visually loss-less to 7500:1 real-time compression and decompression of CCIR-601 digital video at very high image quality

levels. The chips integrate glueless video and host interfaces with on-chip SRAM to permit low part count, system level implementations suitable for a broad range of applications. The ADV611/ADV612 are 100% bitstream compatible with the ADV601. The ADV611/ADV612 comes in a 120-lead LQFP package.

The ADV611/ADV612 are video encoders/decoders optimized for closed circuit TV (CCTV) applications. With the ADV611/ADV612, you can define a portion of each video field to be at a higher quality level relative to the rest of the field. This "quality box" feature significantly increases compression of less important background details, while retaining the image's overall context. Additionally, the unique subband coding architecture of the ADV611/ADV612 offer many application-specific advantages. A review of the General Theory of Operation and Applying the ADV611/ADV612 sections will help you get the most use out of the ADV611/ADV612 in any given application.

The ADV611/ADV612 accept component digital video through the Video Interface and outputs a compressed bitstream through the Host Interface in Encode Mode. While in Decode Mode, the ADV611/ADV612 accept compressed bitstream through the Host Interface and outputs component digital video through the Video Interface. The host accesses all of the ADV611/ADV612's control and status registers using the Host Interface. Figure 2 summarizes the basic function of the part.

(continued on page 2)

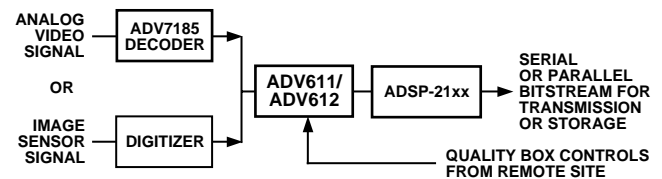
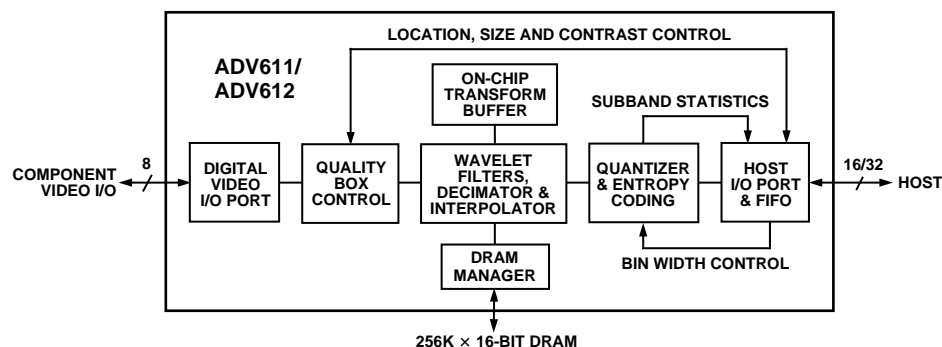

Figure 1. Typical Application

FUNCTIONAL BLOCK DIAGRAM



REV. 0

Information furnished by Analog Devices is believed to be accurate and reliable. However, no responsibility is assumed by Analog Devices for its use, nor for any infringements of patents or other rights of third parties which may result from its use. No license is granted by implication or otherwise under any patent or patent rights of Analog Devices.

ADV611/ADV612

TABLE OF CONTENTS

This data sheet gives an overview of the ADV611/ADV612's functionality and provides details on designing the part into a system. The text of the data sheet is written for an audience with a general knowledge of designing digital video systems. Where appropriate, additional sources of reference material are noted throughout the data sheet.

GENERAL DESCRIPTION	1
COMPARING THE ADV6xx FAMILY VIDEO CODECS	3
INTERNAL ARCHITECTURE	4
GENERAL THEORY OF OPERATION	4
References	5
THE WAVELET KERNEL	5
THE PROGRAMMABLE QUANTIZER	8
THE RUN LENGTH CODER AND HUFFMAN CODER	9
Encoding vs. Decoding	9
PROGRAMMER'S MODEL	9
ADV611/ADV612 REGISTER DESCRIPTIONS	11
VIDEO AREA REGISTERS	14
PIN FUNCTION DESCRIPTIONS	18
Video Interface	21
Video Formats--CCIR-656	22
Host Interface	23
DRAM Manager	23
Compressed Data-Stream Definition	24
APPLYING THE ADV611/ADV612	30
Using the ADV611/ADV612 in Computer Applications	30
Using the ADV611/ADV612 in Stand-Alone Applications	31
Connecting the ADV611/ADV612 to Popular Video Decoders and Encoders	31
GETTING THE MOST OUT OF ADV611/ADV612	32
How Much Compression Can Be Expected	32
Evaluation Board	32
Software Codec	32
Field Rate Reduction	32
Edge Enhancement and Detection	32
Motion Detection	32
ADV611/ADV612 SPECIFICATIONS	33
TEST CONDITIONS	34
TIMING PARAMETERS	34
Clock Signal Timing	34
CCIR-656 Video Format Timing	35
Multiplexed Philips Video Timing	37
Host Interface (Indirect Address, Indirect Register Data, and Interrupt Mask/Status) Register Timing	40
Host Interface (Compressed Data) Register Timing	42
ADV611/ADV612 LQFP PINOUTS	44
ADV611/ADV612 PIN CONFIGURATION	45
OUTLINE DIMENSIONS	46
ORDERING GUIDE	46

GENERAL DESCRIPTION (Continued from page 1)

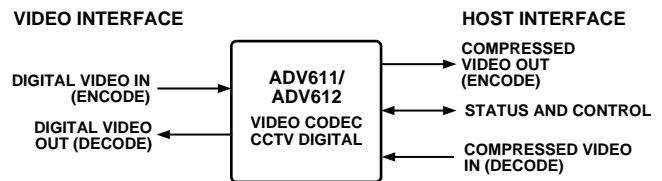

Figure 2. Functional Block Diagram

The ADV611/ADV612 adheres to international standard CCIR-601 for studio quality digital video. The codec also supports a range of field sizes and rates providing high performance in computer, PAL, NTSC, or still image environments. The ADV611/ADV612 is designed only for real-time interlaced video; full frames of video are formed and processed as two independent fields of data. The ADV611/ADV612 supports the field rates and sizes in Table I. Note that the maximum active field size is 720 by 288. The maximum pixel rate is 13.50 MHz.

The ADV611/ADV612 has a generic 16-/32-bit host interface that includes a 512-position, 32-bit wide FIFO for compressed video. With additional external hardware, the ADV611/ADV612's host interface is suitable (when interfaced to other devices) for moving compressed video over PCI, ISA, SCSI, SONET, 10 Base T, ARCnet, HDSL, ADSL and a broad range of digital interfaces. For a full description of the Host Interface, see the Host Interface section.

The compressed data rate is determined by the input data rate and the selected compression ratio. The ADV611/ADV612 can achieve a near constant compressed bit rate by using the current field statistics in the off-chip bin width calculator on the external DSP or Host. The process of calculating bin widths on a DSP or Host can be "adaptive," optimizing the compressed bit rate in real time. This feature provides a near constant bit rate out of the host interface in spite of scene changes or other types of source material changes that would otherwise create bit rate burst conditions. For more information on the quantizer, see the Programmable Quantizer section.

The ADV611/ADV612 typically yields visually loss-less compression on natural images at a 4:1 compression ratio. For more information on compression ratios, see the Getting the Most Out of the ADV611/ADV612 section. Desired image quality levels can vary widely in different applications, so it is advisable to evaluate image quality of known source material at different compression ratios to find the best compression range for the application. The subband coding architecture of the ADV611/ADV612 provides a number of options to stretch compression performance. These options are outlined in the Applying the ADV611/ADV612 section.

Table I. ADV611/ADV612 Field Rates and Sizes

Standard Name	Active Region Horizontal	Active Region Vertical ¹	Total Region Horizontal	Total Region Vertical	Field Rate (Hz)	Pixel Rate (MHz) ²
CCIR-601/525	720	243	858	262.5	59.94	13.50
CCIR-601/625	720	288	864	312.5	50.00	13.50

NOTES

¹The maximum active field size is 720 by 288.

²The maximum pixel rate is 13.5 MHz.



Original Video Image



Image after compression/decompression shown with different box size and position

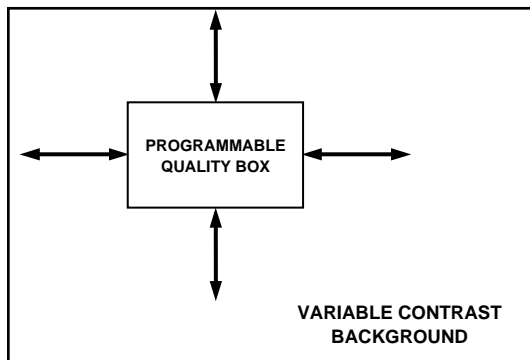

Figure 3.

The ADV611/ADV612 are real-time compression integrated circuits designed for remote video surveillance or closed circuit television (CCTV) applications. The most important feature of these two devices is the “Quality Box.” With this feature the user can define a box of any size and location within each field of video that will be compressed at full contrast while the remainder outside the box, or background of the image, is compressed at a lower level of contrast. The background contrast level is controlled by the user. The lower the contrast level, the more the image will be compressed. The objective in a given

application is to adjust the background contrast to a level that ensures both a recognizable and useful background as well as the highest possible compression. Figure 3 shows how this quality box appears in final video.

The ADV611/ADV612 is housed in a plastic LQFP package suitable for cost-sensitive commercial applications.

COMPARING THE ADV6xx FAMILY VIDEO CODECS

The ADV6xx video codecs support a range of interface, package, and compression features. Table II compares these codecs:

Table II. Differences Between the ADV601, ADV601LC, ADV611 and ADV612

	ADV601	ADV601LC	ADV611	ADV612
Bits per Component	10	8	8	8
DSP Serial Port	Yes	No	No	No
Package	160 PQFP	120 LQFP	120 LQFP	120 LQFP
Pin Assignments	Unique	Unique	98% Similar to ADV601LC	98% Similar to ADV601LC
Temperature Range	0°C to +70°C	0°C to +70°C	0°C to +70°C	-25°C to +85°C
θ_{JA}	31°C/W	35°C/W	35°C/W	35°C/W
θ_{JC}	7.5°C/W	5°C/W	5°C/W	5°C/W
Field Rate Reduction	Software	Software	Hardware	Hardware
Stall Mode	No	No	Yes	Yes
Field Truncation	No	No	Yes	Yes
Field Size Register	No	No	Yes	Yes
Field Bit Polarity Control	No	No	Yes	Yes
Evaluation Board	VideoLab	VideoPipe	CCTVPIPE	CCTVPIPE
Target Applications	Professional	Consumer	CCTV	Industrial CCTV

ADV611/ADV612

INTERNAL ARCHITECTURE

The ADV611/ADV612 is composed of eight blocks. Three of these blocks are interface blocks and five are processing blocks. The interface blocks are the Digital Video I/O Port, the Host I/O Port and the external DRAM manager. The processing blocks are the Wavelet Kernel, the On-Chip Transform Buffer, the Programmable Quantizer, the Run Length Coder and the Huffman Coder.

Digital Video I/O Port

Provides a real-time uncompressed video interface to support a broad range of component digital video formats, including “D1.”

Host I/O Port and FIFO

Carries control, status, and compressed video to and from the host processor. A 512 position by 32-bit FIFO buffers the compressed video stream between the host and the Huffman Coder.

Hardware Field Rate Reduction

In CCTV applications it is often desirable to reduce the field rate to achieve the highest possible compression. The ADV611/ADV612 have special hardware to permit this function. It is possible to set a register on the ADV611/ADV612 during encode mode that will automatically reduce the field rate. This is a 5-bit register that allows up to 31 fields to be “skipped.”

Stall Mode

It is possible to stall or halt the ADV611/ADV612 at any time during Encode Mode. This allows the user to feed uncompressed video data to these parts and to stop indefinitely between fields or even between pixels. This feature is useful when compressing video that is not coming into the ADV611/ADV612 at sustained V_{CLK} rates. Stall Mode is enabled by asserting the Stall pin at any time during encode. Stall mode is enabled on the next clock cycle after the pin is asserted.

Field Size Reporting

The ADV611/ADV612 have a read-only register that allows the user to read the field size of the most recently compressed field. This feature is useful in the feedback loop of a precise bit rate controller. The data is valid after LCODE (unless an entire compressed field resides in the internal FIFO).

DRAM Manager

Performs all tasks related to writing, reading and refreshing the external DRAM. The external host buffer DRAM is used for reordering and buffering quantizer input and output values.

Wavelet Kernel (Filters, Decimator, and Interpolator)

Gathers statistics on a per-field basis and includes a block of filters, interpolators and decimators. The kernel calculates forward and backward bi-orthogonal, two-dimensional, separable wavelet transforms on horizontal scanned video data. This block uses the internal transform buffer when performing wavelet transforms calculated on an entire image’s data and so eliminates any need for extremely fast external memories in an ADV611/ADV612-based design.

On-Chip Transform Buffer

Provides an internal set of SRAM for use by the wavelet transform kernel. Its function is to provide enough delay line storage to support calculation of separable two dimensional wavelet transforms for horizontally scanned images.

Programmable Quantizer

Quantizes wavelet coefficients. Quantize controls are calculated by the external DSP or host processor during encode operations and de-quantize controls are extracted from the compressed bitstream during decode. Each quantizer Bin Width is computed by the BW calculator software to maintain a constant compressed bit rate or constant quality bit rate. A Bin Width is a per-block parameter the quantizer uses when determining the number of bits to allocate to each block (subband).

Quality Box

The quality box is defined using the Video Area Registers that are described in the Registers Descriptions section. The background contrast is controlled using Background Contrast Registers that are defined later in this document. It is possible to control both parameters on a per-field basis during Encode Mode. This enables the quality box to either move slowly across the image or to instantaneously jump from one location to the next.

Run Length Coder

Performs run length coding on zero data and models nonzero data, encoding or decoding for more efficient Huffman coding. This data coding is optimized across the subbands and varies depending on the block being coded.

Huffman Coder

Performs Huffman coder and decoder functions on quantized run-length coded coefficient values. The Huffman coder/decoder uses three ROM-coded Huffman tables that provide excellent performance for wavelet transformed video.

Field Truncation

It is possible to set a hard upper limit to the field size of each field during Encode Mode. The Huffman Coder is able to detect if the field size exceeds a preset threshold and then causes the remaining Mallat block data to be zeroed out, therefore, truncating the field’s data. The bitstream is truncated in such a way that all end-of-field markers are inserted. This means that the compressed bitstream can still be decompressed by any hardware or software ADV6xx decoder. The only penalty is the loss of Mallat blocks which, depending on how many are lost, will degrade the image quality of the truncated field.

GENERAL THEORY OF OPERATION

The ADV611/ADV612 processor’s compression algorithm is based on the bi-orthogonal (7, 9) wavelet transform, and implements field independent subband coding. Subband coders transform two-dimensional spatial video data into spatial frequency filtered subbands. The quantization and entropy encoding processes provide the ADV611/ADV612’s data compression.

The wavelet theory, on which the ADV611/ADV612 is based, is a new mathematical apparatus first explicitly introduced by Morlet and Grossman in their works on geophysics during the mid 80s. This theory became very popular in theoretical physics and applied math. The late 80s and 90s have seen a dramatic growth in wavelet applications such as signal and image processing. For more on wavelet theory by Morlet and Grossman, see *Decomposition of Hardy Functions into Square Integrable Wavelets of Constant Shape* (journal citation listed in References section).

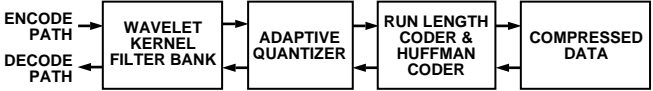

Figure 4. Encode and Decode Paths

References

For more information on the terms, techniques and underlying principles referred to in this data sheet, you may find the following reference texts useful. A reference text for general digital video principles is:

Jack, K., *Video Demystified: A Handbook for the Digital Engineer* (High Text Publications, 1993) ISBN 1-878707-09-4

Three reference texts for wavelet transform background information are:

Vetterli, M., Kovacevic, J., *Wavelets And Subband Coding* (Prentice Hall, 1995) ISBN 0-13-097080-8

Benedetto, J., Frazier, M., *Wavelets: Mathematics And Applications* (CRC Press, 1994) ISBN 0-8493-8271-8

Grossman, A., Morlet, J., *Decomposition of Hardy Functions into Square Integrable Wavelets of Constant Shape*, Siam. J. Math. Anal., Vol. 15, No. 4, pp 723-736, 1984

THE WAVELET KERNEL

This block contains a set of filters and decimators that work on the image in both horizontal and vertical directions. Figure 8 illustrates the filter tree structure. The filters apply carefully chosen wavelet basis functions that better correlate to the broadband nature of images than the sinusoidal waves used in Discrete Cosine Transform (DCT) compression schemes (JPEG, MPEG, and H261).

An advantage of wavelet-based compression is that the entire image can be filtered without being broken into sub-blocks as required in DCT compression schemes. This full image filtering eliminates the block artifacts seen in DCT compression and offers more graceful image degradation at high compression ratios. The availability of full image subband data also makes

image processing, scaling, and a number of other system features possible with little or no computational overhead.

The resultant filtered image is made up of components of the original image as is shown in Figure 5 (a modified Mallat Tree). Note that Figure 5 shows how a component of video would be filtered, but in multiple component video, luminance and color components are filtered separately. In Figure 6 and Figure 7 an actual image and the Mallat Tree (luminance only) equivalent is shown. It is important to note that while the image has been filtered or transformed into the frequency domain, no compression has occurred. With the image in its filtered state, it is now ready for processing in the second block, the quantizer.

Understanding the structure and function of the wavelet filters and resultant product is the key to obtaining the highest performance from the ADV611/ADV612. Consider the following points:

- The data in all blocks (except N) for all components are high pass filtered. Therefore, the mean pixel value in those blocks is typically zero and a histogram of the pixel values in these blocks will contain a single “hump” (Laplacian distribution).
- The data in most blocks is more likely to contain zeros or strings of zeros than unfiltered image data.
- The human visual system is less sensitive to higher frequency blocks than low ones.
- Attenuation of the selected blocks in luminance or color components results in control over sharpness, brightness, contrast and saturation.
- High quality filtered/decimated images can be extracted/created without computational overhead.

Through leverage of these key points, the ADV611/ADV612 not only compresses video, but offers a host of application features. Please see the Applying the ADV611/ADV612 section for details on getting the most out of the ADV611/ADV612’s subband coding architecture in different applications.

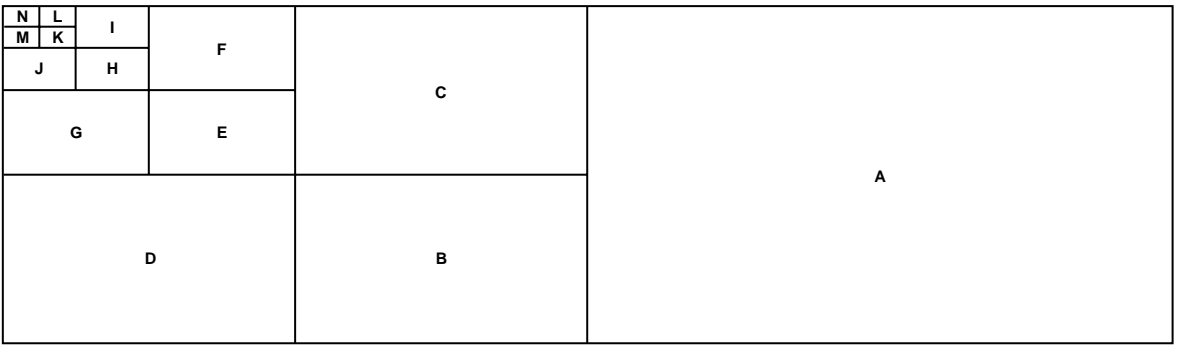

BLOCK A IS HIGH PASS IN X AND DECIMATED BY TWO.
 BLOCK B IS HIGH PASS IN X, HIGH PASS IN Y, AND DECIMATED BY EIGHT.
 BLOCK C IS HIGH PASS IN X, LOW PASS IN Y, AND DECIMATED BY EIGHT.
 BLOCK D IS LOW PASS IN X, HIGH PASS IN Y, AND DECIMATED BY EIGHT.
 BLOCK E IS HIGH PASS IN X, HIGH PASS IN Y, AND DECIMATED BY 32.
 BLOCK F IS HIGH PASS IN X, LOW PASS IN Y, AND DECIMATED BY 32.
 BLOCK G IS LOW PASS IN X, HIGH PASS IN Y, AND DECIMATED BY 32.
 BLOCK H IS HIGH PASS IN X, HIGH PASS IN Y, AND DECIMATED BY 128.
 BLOCK I IS HIGH PASS IN X, LOW PASS IN Y, AND DECIMATED BY 128.
 BLOCK J IS LOW PASS IN X, HIGH PASS IN Y, AND DECIMATED BY 128.
 BLOCK K IS HIGH PASS IN X, HIGH PASS IN Y, AND DECIMATED BY 512.
 BLOCK L IS HIGH PASS IN X, LOW PASS IN Y, AND DECIMATED BY 512.
 BLOCK M IS LOW PASS IN X, HIGH PASS IN Y, AND DECIMATED BY 512.
 BLOCK N IS LOW PASS IN X, LOW PASS IN Y, AND DECIMATED BY 512.

Figure 5. Modified Mallat Diagram (Block Letters Correspond to Those in Filter Tree)



Figure 6. Unfiltered Original Image (Analog Devices Corporate Offices, Norwood, Massachusetts)

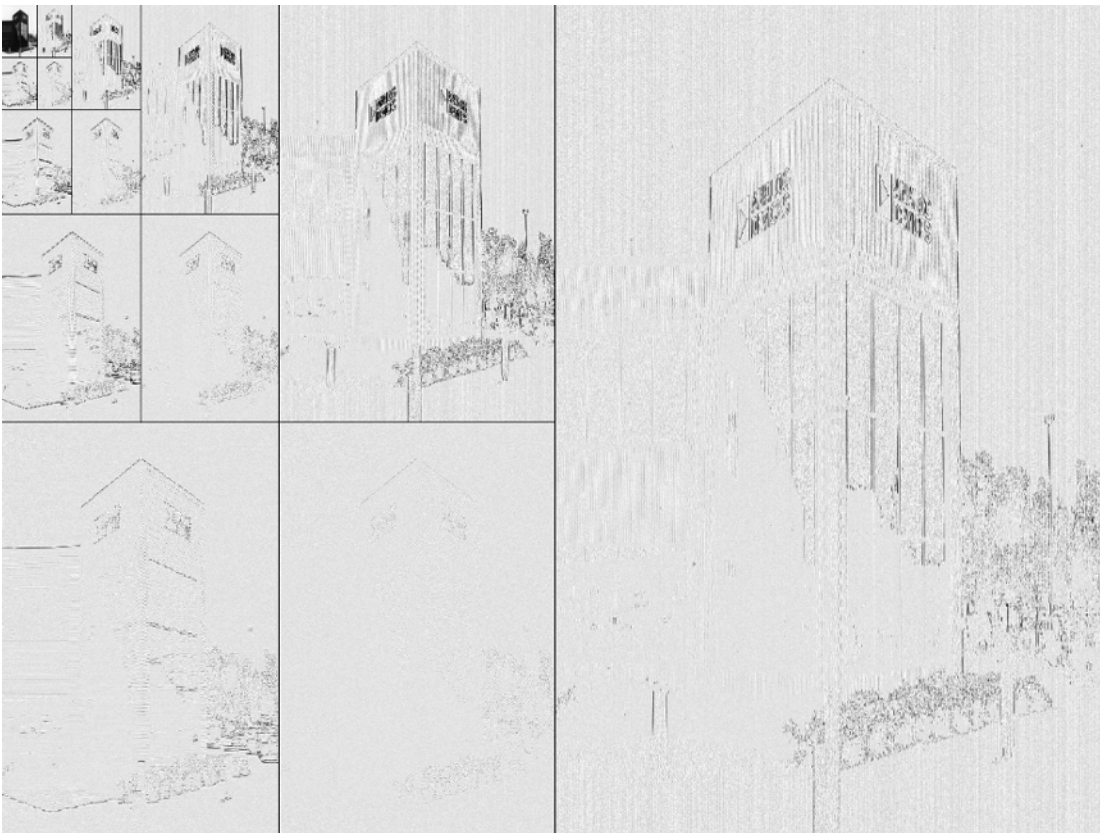

Figure 7. Modified Mallat Diagram of Image

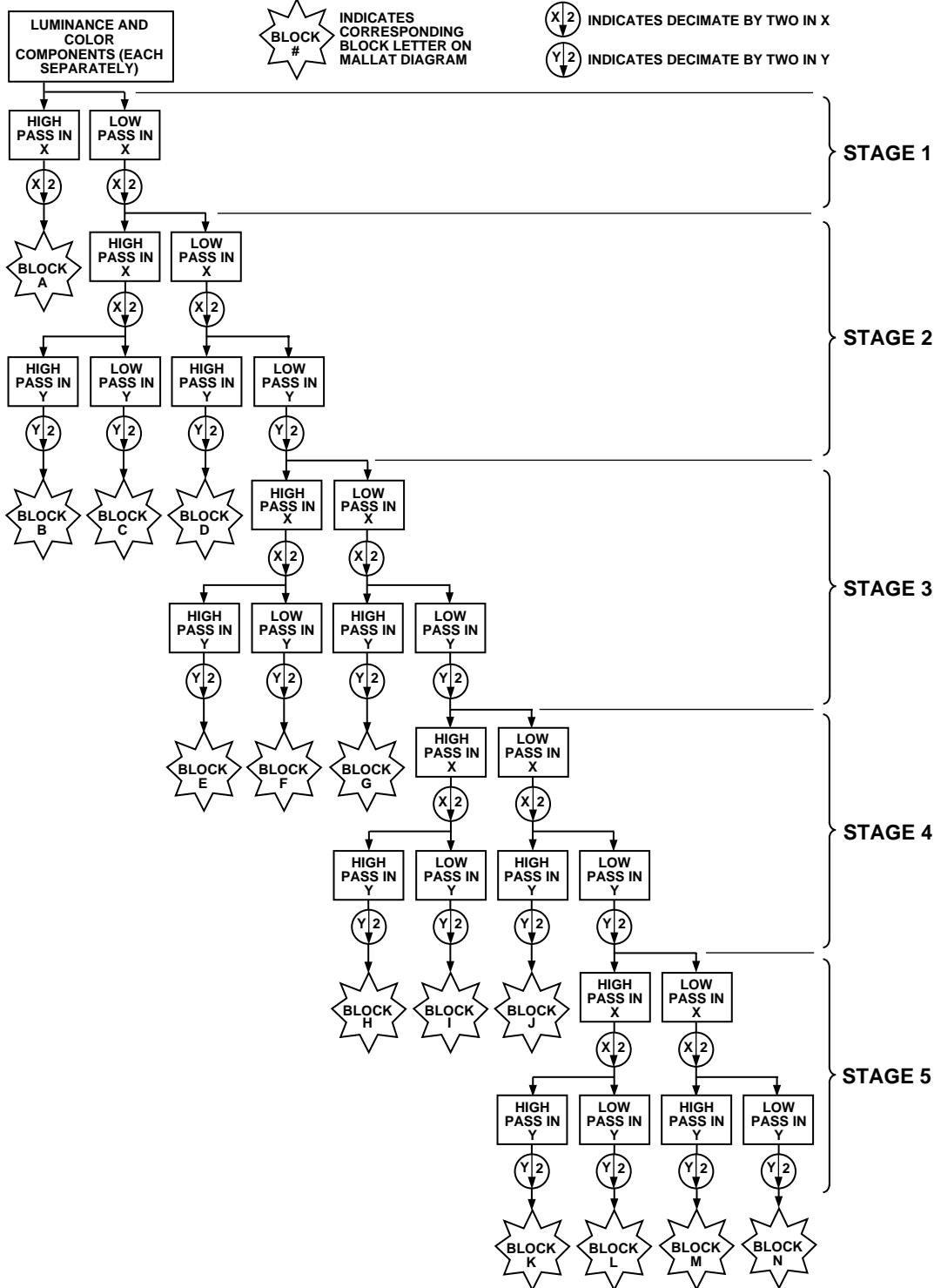

Figure 8. Wavelet Filter Tree Structure

ADV611/ADV612

THE PROGRAMMABLE QUANTIZER

This block quantizes the filtered image based on the response profile of the human visual system. In general, the human eye cannot resolve high frequencies in images to the same level of accuracy as lower frequencies. Through intelligent “quantization” of information contained within the filtered image, the ADV611/ADV612 achieves compression without compromising the visual quality of the image. Figure 9 shows the encode and decode data formats used by the quantizer.

Figure 10 shows how a typical quantization pattern applies over Mallat block data. The high frequency blocks receive much larger quantization (appear darker) than the low frequency blocks (appear lighter). Looking at this figure, one sees some key point concerning quantization: (1) quantization relates directly to frequency in Mallat block data and (2) levels of quantization range widely from high to low frequency block. (Note that the fill is based on a log formula.) The relation between actual ADV611/ADV612 bin width factors and the Mallat block fill pattern in Figure 10 appears in Table III.

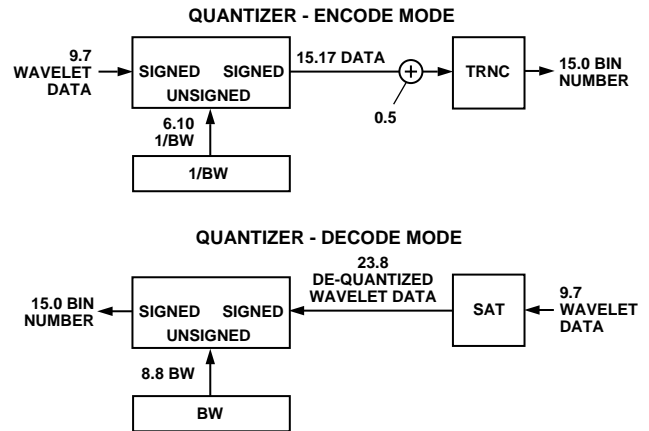

Figure 9. Programmable Quantizer Data Flow

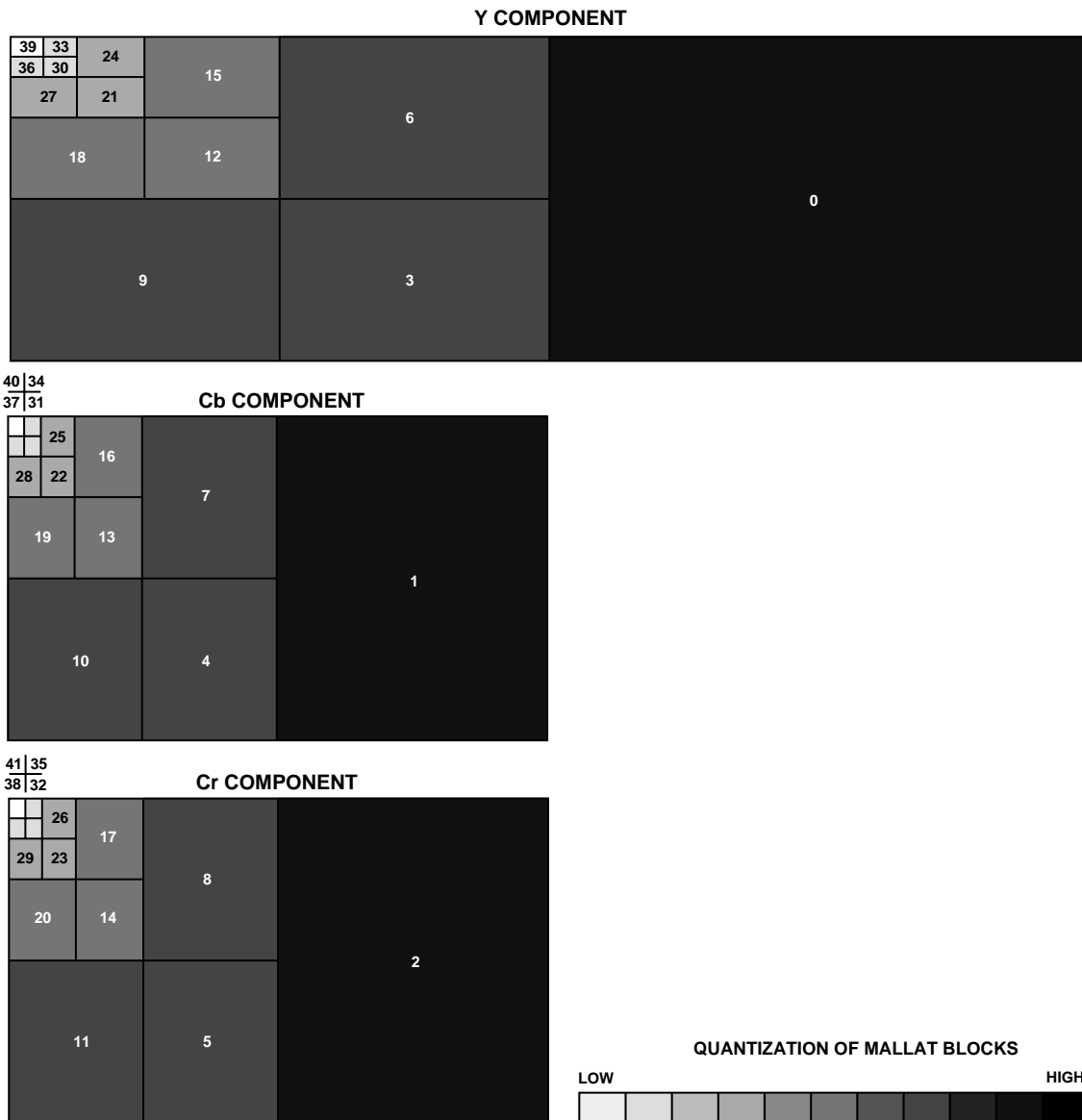

Figure 10. Typical Quantization of Mallat Data Blocks (Graphed)

ADV611/ADV612

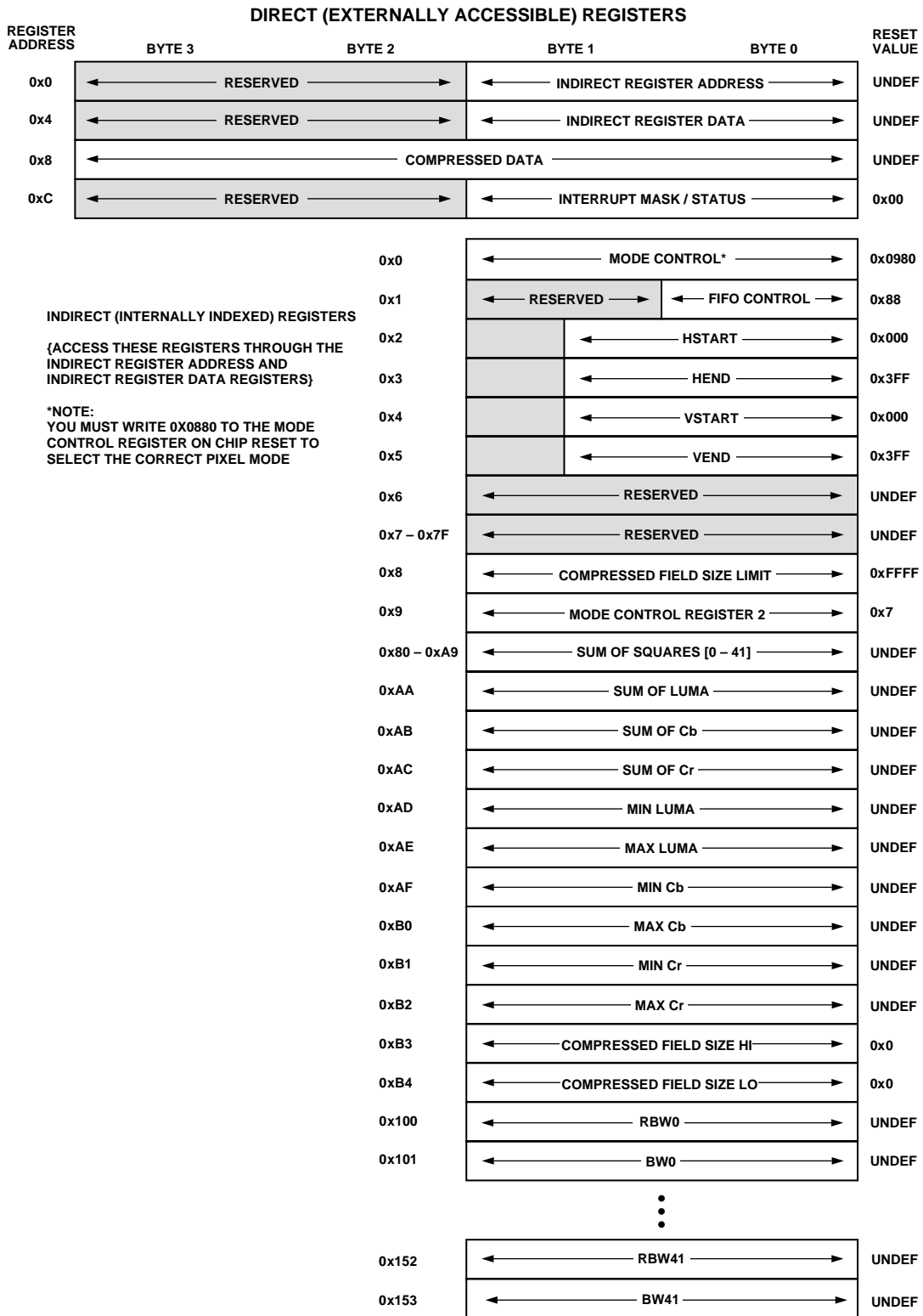

Figure 11. Map of ADV611/ADV612 Direct and Indirect Registers

ADV611/ADV612 REGISTER DESCRIPTIONS**Indirect Address Register**

Direct (Write) Register Byte Offset 0x00.

This register holds a 16-bit value (index) that selects the indirect register accessible to the host through the indirect data register. All indirect write registers are 16 bits wide. The address in this register is auto-incremented on each subsequent access of the indirect data register. This capability enhances I/O performance during modes of operation where the host is calculating Bin Width controls.

[15:0] Indirect Address Register, **IAR[15:0]**. Holds a 16-bit value (index) that selects the indirect register to read or write through the indirect data register (undefined at reset).

[31:16] Reserved (undefined read/write zero)

Indirect Register Data

Direct (Read/Write) Register Byte Offset 0x04

This register holds a 16-bit value read or written from or to the indirect register indexed by the Indirect Address Register.

[15:0] Indirect Register Data, **IRD[15:0]**. A 16-bit value read or written to the indexed indirect register. Undefined at reset.

[31:16] Reserved (undefined read/write zero)

Compressed Data Register

Direct (Read/Write) Register Byte Offset 0x08

This register holds a 32-bit sequence from the compressed video bitstream. This register is buffered by a 512 position, 32-bit FIFO. For Word (16-bit) accesses, access Word0 (Byte 0 and Byte 1) then Word1 (Byte 2 and Byte 3) for correct auto-increment. For a description of the data sequence, see the Compressed Data Stream Definition section.

[31:0] Compressed Data Register, **CDR[31:0]**. 32-bit value containing compressed video stream data. At reset, contents undefined.

Interrupt Mask / Status Register

Direct (Read/Write) Register Byte Offset 0x0C

This 16-bit register contains interrupt mask and status bits that control the state of the ADV611/ADV612's $\overline{\text{HIRQ}}$ pin. With the seven mask bits (IE_LCODE, IE_STATSR, IE_FIFOSTP, IE_FIFOSRQ, IE_FIFOERR, IE_CCIRER, IE_MERR), select the conditions that are ORed together to determine the output of the $\overline{\text{HIRQ}}$ pin.

Six of the status bits (LCODE, STATSR, FIFOSTP, MERR, FIFOERR, CCIRER) indicate active interrupt conditions and are sticky bits that stay set until read. Because sticky status bits are cleared when read, and these bits are set on the positive edge of the condition coming true, they cannot be read or tested for stable level true conditions multiple times.

The FIFOSRQ bit is not sticky. This bit can be polled to monitor for a FIFOSRQ true condition. Note: Enable this monitoring by using the FIFOSRQ bit and correctly programming DSL and ESL fields within the FIFO control registers.

[0] CCIR-656 Error in CCIR-656 data stream, **CCIRER**. This read only status bit indicates the following:

- 0 No CCIR-656 Error condition, *reset value*
- 1 Unrecoverable error in CCIR-656 data stream (missing sync codes)

[1] Statistics Ready, **STATSR**. This read only status bit indicates the following:

- 0 No Statistics Ready condition, *reset value* (STATS_R pin LO)
- 1 Statistics Ready for BW calculator (STATS_R pin HI)

[2] Last Code Read, **LCODE**. This read only status bit indicates the last compressed data word for field will be retrieved from the FIFO on the next read from the host bus.

- 0 No Last Code condition, *reset value* (LCODE pin LO)
- 1 Next read retrieves last word for field in FIFO (LCODE pin HI)

[3] FIFO Service Request, **FIFOSRQ**. This read only status bit indicates the following:

- 0 No FIFO Service Request condition, *reset value* (FIFO_SRQ pin LO)
- 1 FIFO is nearly full (encode) or nearly empty (decode) (FIFO_SRQ pin HI)

[4] FIFO Error, **FIFOERR**. This condition indicates that the host has been unable to keep up with the ADV611/ADV612's compressed data supply or demand requirements. If this condition occurs during encode, the data stream will not be corrupted until MERR indicates that the DRAM has also overflowed. If this condition occurs during decode, the video output will be corrupted. If the system overflows the FIFO (disregarding a FIFOSTP condition) with too many writes in decode mode, FIFOERR is asserted. This read only status bit indicates the following:

- 0 No FIFO Error condition, *reset value* (FIFO_ERR pin LO)
- 1 FIFO overflow (encode) or underflow (decode) (FIFO_ERR pin HI)

ADV611/ADV612

- [5] FIFO Stop, **FIFOSTP**. This condition indicates that the FIFO is full in decode mode and empty in encode mode. In decode mode only, FIFOSTP status actually behaves more conservatively than this. In decode mode, even when FIFOSTP is indicated, there are still 32 empty Dwords available in the FIFO and 32 more Dword writes can safely be performed. This status bit indicates the following:
- 0 No FIFO Stop condition, *reset value* (FIFO_STP pin LO)
 - 1 FIFO empty (encode) or full (decode) (FIFO_STP pin HI)
- [6] Memory Error, **MERR**. This condition indicates that an error has occurred at the DRAM memory interface. This condition can be caused by a defective DRAM, the inability of the Host to keep up with the ADV611/ADV612 compressed data stream, or bit errors in the data stream. Note that the ADV611/ADV612 recovers from this condition without host intervention.
- 0 No memory error condition, *reset value*
 - 1 Memory error
- [7] Reserved (always read/write zero)
- [8] Interrupt Enable on CCIRER, **IE_CCIRER**. This mask bit selects the following:
- 0 Disable CCIR-656 data error interrupt, *reset value*
 - 1 Enable interrupt on error in CCIR-656 data
- [9] Interrupt Enable on STATR, **IE_STATR**. This mask bit selects the following:
- 0 Disable Statistics Ready interrupt, *reset value*
 - 1 Enable interrupt on Statistics Ready
- [10] Interrupt Enable on LCODE, **IE_LCODE**. This mask bit selects the following:
- 0 Disable Last Code Read interrupt, *reset value*
 - 1 Enable interrupt on Last Code Read from FIFO
- [11] Interrupt Enable on FIFOSRQ, **IE_FIFOSRQ**. This mask bit selects the following:
- 0 Disable FIFO Service Request interrupt, *reset value*
 - 1 Enable interrupt on FIFO Service Request
- [12] Interrupt Enable on FIFOERR, **IE_FIFOERR**. This mask bit selects the following:
- 0 Disable FIFO Stop interrupt, *reset value*
 - 1 Enable interrupt on FIFO Stop
- [13] Interrupt Enable on FIFOSTP, **IE_FIFOSTP**. This mask bit selects the following:
- 0 Disable FIFO Error interrupt, *reset value*
 - 1 Enable interrupt on FIFO Error
- [14] Interrupt Enable on MERR, **IE_MERR**. This mask bit selects the following:
- 0 Disable memory error interrupt, *reset value*
 - 1 Enable interrupt on memory error
- [15] Reserved (always read/write zero)
-

Mode Control Register

Indirect (Read/Write) Register Index 0x00

This register holds configuration data for the ADV611/ADV612's video interface format and controls several other video interface features. For more information on formats and modes, see the Video Interface section. Bits in this register have the following functions:

- [3:0] Video Interface Format, **VIF[3:0]**. These bits select the interface format. Valid settings include the following (all other values are reserved):
- 0x0 CCIR-656, *reset value*
 - 0x2 MLTPX (Philips)
- [4] VCLK Output Divided by two, **VCLK2**. This bit controls the following:
- 0 Do not divide VCLK output (VCLKO = VCLK), *reset value*
 - 1 Divide VCLK output by two (VCLKO = VCLK/2)
- [5] Video Interface Master/Slave Mode Select, **M/S**. This bit selects the following:
- 0 Slave mode video interface (External control of video timing, HSYNC-VSYNC-FIELD are inputs), *reset value*
 - 1 Master mode video interface (ADV611/ADV612 controls video timing, HSYNC-VSYNC are outputs)
- [6] Video Interface 525/625 (NTSC/PAL) Mode Select, **P/N**. This bit selects the following:
- 0 525 mode video interface, *reset value*
 - 1 625 mode video interface

- [7] Video Interface Encode/Decode Mode Select, **E/D**. This bit selects the following:
 - 0 Decode mode video interface (compressed-to-raw)
 - 1 Encode mode video interface (raw-to-compressed), *reset value*
- [8] Reserved (always write zero)
- [9] Video Interface Bipolar/Unipolar Color Component Select, **BC**. This bit selects the following:
 - 0 Bipolar color component mode video interface, *reset value*
 - 1 Unipolar color component mode video interface
- [10] Reserved (always write zero)
- [11] Video Interface Software Reset, **SWR**. This bit has the following effects on ADV611/ADV612 operations:
 - 0 Normal operation
 - 1 Software Reset. This bit is set on hardware reset and must be cleared before the ADV611/ADV612 can begin processing. (*reset value*)
 When this bit is set during encode, the ADV611/ADV612 completes processing the current field then suspends operation until the SWR bit is cleared. When this bit is set during decode, the ADV611/ADV612 suspends operation immediately and does not resume operation until the SWR bit is cleared. Note that this bit must be set whenever any other bit in the Mode register is changed.
- [12] HSYNC pin Polarity, **PHSYNC**. This bit has the following effects on ADV611/ADV612 operations:
 - 0 HSYNC is HI during blanking, *reset value*
 - 1 HSYNC is LO during blanking (HI during active)
- [13] $\overline{\text{HIRQ}}$ pin Polarity, **PHIRQ**. This bit has the following effects on ADV611/ADV612 operations:
 - 0 $\overline{\text{HIRQ}}$ is active LO, *reset value*
 - 1 $\overline{\text{HIRQ}}$ is active HI
- [14] Quality Box Enable, **QBE**. This bit has the following effect on ADV611/ADV612 operations:
 - 0 Video area registers (HSTART, HEND, VSTART, VEND). Crop video area, setting cropped area to all 0 quantizations (ADV601 mode), *reset value*
 - 1 Video area registers (HSTART, HEND, VSTART, VEND). Select Quality Box. Quantization of the area outside the box is selected with the background Contrast Control register. See the video area registers for more information on the Quality Box.
- [15] Video Stall Enable, **VSE**. This bit has the following effect on ADV611/ADV612 operations:
 - 0 Video Stall disabled (ADV601 mode), *reset value*
 - 1 Video Stall enabled.

FIFO Control Register

Indirect (Read/Write) Register Index 0x01

This register holds the service-request settings for the ADV611/ADV612's host interface FIFO, causing interrupts for the "nearly full" and "nearly empty" levels. Because each register is four bits in size, and the FIFO is 512 positions, the 4-bit value must be multiplied by 32 (decimal) to determine the exact value for encode service level (nearly full) and decode service level (nearly empty). The ADV611/ADV612 uses these settings to determine when to generate a FIFO Service Request related host interrupt (FIFOSRQ bit and FIFO_SRQ pin).

- [3:0] Encode Service Level, **ESL[3:0]**. The value in this field determines when the FIFO is considered nearly full on encode; a condition that generates a FIFO service request condition in encode mode. Since this register is four bits (16 states), and the FIFO is 512 positions, the step size for each bit in this register is 32 positions. The following table summarizes sample states of the register and their meaning.

ESL	Interrupt When . . .
0000	Disables service requests (FIFO_SRQ never goes HI during encode)
0001	FIFO has only 32 positions filled (FIFO_SRQ when \geq 32 positions are filled)
1000	FIFO is 1/2 full, <i>reset value</i>
1111	FIFO has only 32 positions empty (480 positions filled)
- [7:4] Decode Service Level, **DSL[7:4]**. The value in this field determines when the FIFO is considered nearly empty in decode; a condition that generates a FIFO service request in decode mode. Because this register is four bits (16 states), and the FIFO is 512 positions, the step size for each bit in this register is 32 positions. The following table summarizes sample states of the register and their meaning.

DSL	Interrupt When . . .
0000	Disables service requests (FIFO_SRQ never goes HI)
0001	FIFO has only 32 positions filled (480 positions empty)
1000	FIFO is 1/2 empty, <i>reset value</i>
1111	FIFO has only 32 positions empty (FIFO_SRQ when \geq 32 positions are empty)
- [15:8] Reserved (always write zero)

ADV611/ADV612

VIDEO AREA REGISTERS

When the quality box is disabled (Mode Control register, Bit 14 = 0), the area defined by the HSTART, HEND, VSTART and VEND registers is the active area that the wavelet kernel processes. Video data outside the active video area is set to minimum luminance and zero chrominance (black) by the ADV611/ADV612. These registers allow cropping of the input video during compression (encode only), but do not change the image size. Figure 12 shows how the video area registers work together.

Some comments on how these registers work are as follows:

- The vertical numbers include the blanking areas of the video.

Specifically, a VSTART value of 21 will include the first line of active video, and the first pixel in a line corresponds to a value HSTART of 0 (for NTSC regular).

Note that the vertical coordinates start with 1, whereas the horizontal coordinates start with 0.

- The default cropping mode is set for the entire frame. Specifically, Field 2 starts at a VSTART value of 283 (for NTSC regular).

When the quality box is enabled (Mode Control register, Bit 14 = 1), the area defined by the HSTART, HEND, VSTART and VEND registers is the quality box area, and the rest of the video area is attenuated according to the value in the background Contrast Control register (Indirect Register Index 0x9). In this mode, the range of values for VSTART and VEND is 1–243 for NTSC and 1–288 for PAL. Also note that VSTART and VEND do not need to be updated for each field in this mode.

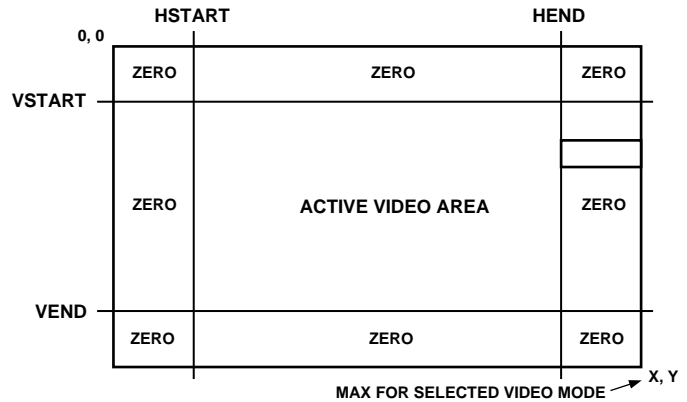

Figure 12. Video Area and Video Area Registers

HSTART Register

Indirect (Write Only) Register Index 0x02

This register holds the setting for the horizontal start of the ADV611/ADV612's active video area or quality box. The value in this register is usually set to zero, but in cases where you wish to crop incoming video it is possible to do so by changing HST.

[9:0] Horizontal Start, **HST[9:0]**. 10-bit value defining the start of the active video region. (0 at reset)

[15:10] Reserved (always write zero)

HEND Register

Indirect (Write Only) Register Index 0x03

This register holds the setting for the horizontal end of the ADV611/ADV612's active video area or quality box. If the value is larger than the max size of the selected video mode, the ADV611/ADV612 uses the max size of the selected mode for HEND.

[9:0] Horizontal End, **HEN[9:0]**. 10-bit value defining the end of the active video region. (0x3FF at reset this value is larger than the max size of the largest video mode)

[15:10] Reserved (always write zero)

VSTART Register

Indirect (Write Only) Register Index 0x04

This register holds the setting for the vertical start of the ADV611/ADV612's active video area or quality box. The value in this register is usually set to zero unless you want to crop the active video.

To vertically crop video while encoding, program the VSTART and VEND registers with actual video line numbers, which differ for each field. The VSTART and VEND contents must be updated on each field unless the quality box is enabled. Perform this updating as part of the field-by-field BW register update process. To perform this dynamic update correctly, the update software must keep track of which field is being processed next.

[9:0] Vertical Start, **VST[9:0]**. 10-bit value defining the starting line of the active video region, with line numbers from 1-to-625 in PAL and 1-to-525 in NTSC. (0 at reset)

[15:10] Reserved (always write zero)

VEND Register

Indirect (Write Only) Register Index 0x05

This register holds the setting for the vertical end of the ADV611/ADV612's active video area or quality box. If the value is larger than the max size of the selected video mode, the ADV611/ADV612 uses the max size of the selected mode for VEND.

To vertically crop video while encoding, program the VSTART and VEND registers with actual video line numbers, which differ for each field. The VSTART and VEND contents must be updated on each field, unless the quality box is enabled. Perform this updating as part of the field-by-field BW register update process. To perform this dynamic update correctly, the update software must keep track of which field is being processed next.

- [9:0] Vertical End, **VEN[9:0]**. 10-bit value defining the ending line of the active video region, with line numbers from 1-to-625 in PAL and 1-to-525 in NTSC. (0x3FF at reset—this value is larger than the max size of the largest video mode)
- [15:10] Reserved (always write zero)

Compressed Field Size Limit

Indirect (Read/Write) Register Index 0x8

- [15:0] The DWORD Max Count 16 MSBs register selects the maximum number of double (32-bit) words for an encoded field. When the value in the DWORD count registers reaches the DWORD Max Count, the Quantizer zeroes out all remaining samples in the field. To enable the DWORD Max Counts operation, you must set (= 1) Bit 4 in Indirect register 0x7; all other bits in Indirect register 0x7 are reserved (= 0). Note that the 4 LSBs of the max count are 0000, so the max count is selectable in 16-word increments. Contains bits [19:4] of the DWORD max count, reset to 0xffff

Mode Control #2

Indirect (Read/Write) Register Index 0x9

- [2:0] These bits control the contrast/attenuation of the area outside the quality box when the quality box is enabled. The following settings control background contrast.

Setting	Contrast/Attenuation
000	Illegal
001	6 dB
010	12 dB
011	18 dB
100	24 dB
101	30 dB
- [3] Field Polarity Bit. This bit reverses the polarity of the FIELD pin. This bit operates as follows:
 - 0 Normal Field Polarity (ADV601 Mode), *reset value*
 - 1 Reverse Field Polarity. Polarity is opposite to the polarity in the FIELD pin timing diagrams.
- [8:4] Field Rate Reduction. To reduce this compressed data rate, the ADV601 can discard some video fields. Set field rate reduction to zero to capture all fields, one to discard every other field, two to discard two fields out of three and so on. Maximum possible field rate reduction send only one field out of 32.
- [9] Reserved, must set to 1. This bit must be set to take advantage of MERR detection logic. Resets to 0.
- [10] Reserved, resets to 1.
- [11] Ignore Field bit in decode, setting this bit eliminates black fields if field bits repeat from field to field in decode mode, resets to 0.

Sum of Squares [0–41] Registers

Indirect (Read Only) Register Index 0x080 through 0x0A9

The Sum of Squares [0–41] registers hold values that correspond to the summation of squared values in corresponding Mallat blocks [0–41]. These registers let the Host or DSP read sum of squares statistics from the ADV611/ADV612; using these values (with the Sum of Value, MIN Value, and MAX Value) the host or DSP can then calculate the BW and RBW values. The ADV611/ADV612 indicates that the sum of squares statistics have been updated by setting (1) the STATR bit and asserting the STAT_R pin. Read the statistics at any time. The Host reads these values through the Host Interface.

- [15:0] Sum of Squares, **STS[15:0]**. 16-bit values [0-41] for corresponding Mallat blocks [0-41] (undefined at reset). Sum of Square values are 16-bit codes that represent the Most Significant Bits of values ranging from 40 bits for small blocks to 48 bits for large blocks. The 16-bit codes have the following precision:

Blocks	Precision	Sum of Squares Precision Description
0–2	48.–32	48.-bits wide, left shift code by 32-bits, and zero fill
3–11	46.–30	46.-bits wide, left shift code by 30-bits, and zero fill
12–20	44.–28	44.-bits wide, left shift code by 28-bits, and zero fill
21–29	42.–26	42.-bits wide, left shift code by 26-bits, and zero fill
30–41	40.–24	40.-bits wide, left shift code by 24-bits, and zero fill

If the Sum of Squares code were 0x0025 for block 10, the actual value would be 0x000940000000; if using that same code, 0x0025, for block 30, the actual value would be 0x0025000000.

- [31:0] Reserved (always read zero)

ADV611/ADV612

Sum of Luma Value Register

Indirect (Read Only) Register Index 0x0AA

The Sum of Luma Value register lets the host or DSP read the sum of pixel values for the Luma component in block 39. The Host reads these values through the Host Interface.

[15:0] Sum of Luma, **SL[15:0]**. 16-bit component pixel values (undefined at reset)

[31:0] Reserved (always read zero)

Sum of Cb Value Register

Indirect (Read Only) Register Index 0x0AB

The Sum of Cb Value register lets the host or DSP read the sum of pixel values for the Cb component in block 40. The Host reads these values through the Host Interface.

[15:0] Sum of Cb, **SCB[15:0]**. 16-bit component pixel values (undefined at reset)

[31:0] Reserved (always read zero)

Sum of Cr Value Register

Indirect (Read Only) Register Index 0x0AC

The Sum of Cr Value register lets the host or DSP read the sum of pixel values for the Cr component in block 41. The Host reads these values through the Host Interface.

[15:0] Sum of Cr, **SCR[15:0]**. 16-bit component pixel values (undefined at reset)

[31:0] Reserved (always read zero)

MIN Luma Value Register

Indirect (Read Only) Register Index 0x0AD

The MIN Luma Value register lets the host or DSP read the minimum pixel value for the Luma component in the unprocessed data. The Host reads these values through the Host Interface.

[15:0] Minimum Luma, **MNL[15:0]**. 16-bit component pixel value (undefined at reset)

[31:0] Reserved (always read zero)

MAX Luma Value Register

Indirect (Read Only) Register Index 0x0AE

The MAX Luma Value register lets the host or DSP read the maximum pixel value for the Luma component in the unprocessed data. The Host reads these values through the Host Interface.

[15:0] Maximum Luma, **MXL[15:0]**. 16-bit component pixel value (undefined at reset)

[31:0] Reserved (always read zero)

MIN Cb Value Register

Indirect (Read Only) Register Index 0x0AF

The MIN Cb Value register lets the host or DSP read the minimum pixel value for the Cb component in the unprocessed data. The Host reads these values through the Host Interface.

[15:0] Minimum Cb, **MNCB[15:0]**. 16-bit component pixel value (undefined at reset)

[31:0] Reserved (always read zero)

MAX Cb Value Register

Indirect (Read Only) Register Index 0x0B0

The MAX Cb Value register lets the host or DSP read the maximum pixel value for the Cb component in the unprocessed data. The Host reads these values through the Host Interface.

[15:0] Maximum Cb, **MXCB[15:0]**. 16-bit component pixel value (undefined at reset)

[31:0] Reserved (always read zero)

MIN Cr Value Register

Indirect (Read Only) Register Index 0x0B1

The MIN Cr Value register lets the host or DSP read the minimum pixel value for the Cr component in the unprocessed data. The Host reads these values through the Host Interface.

[15:0] Minimum Cr, **MNCR[15:0]**. 16-bit component pixel value (undefined at reset)

[31:0] Reserved (always read zero)

MAX Cr Value Register

Indirect (Read Only) Register Index 0x0B2

The MAX Cr Value register lets the host or DSP read the maximum pixel value for the Cr component in the unprocessed data. The Host reads these values through the Host Interface.

[15:0] Maximum Cr, **MXCR[15:0]**. 16-bit component pixel value (undefined at reset)

[31:0] Reserved (always read zero)

Compressed Field Size [HI]

Indirect (Read Only) Register Index 0x83

[15:0] The DWORD Count registers hold the count of double (32-bit) words contained in the previously encoded field. This count is useful for bit rate control algorithms that use a servo loop, which is locked to the expected number of double words in the field. The registers are double buffered to ensure that the count remains constant while the next field's count accumulates. Contains bits [19:4] of the DWORD count, reset is 0.

Compressed Field Size [LO]

Indirect (Read Only) Register Index 0xB4

[3:0] Contains bits [3:0] of the DWORD count, reset is 0. For more information, see the DWORD Count 16 MSB Register description.

Bin Width and Reciprocal Bin Width Registers

Indirect (Read/Write) Register Index 0x0100-0x0153

The RBW and BW values are calculated by the host or DSP from data in the Sum of Squares [0-41], Sum of Value, MIN Value, and MAX Value registers; then are written to RBW and BW registers during encode mode to control the quantizer. The Host writes these values through the Host Interface.

These registers contain a 16-bit interleaved table of alternating RBW/BW (RBW-even addresses and BW-odd addresses) values as indexed on writes by address register. Bin Widths are 8.8, unsigned, 16-bit, fixed-point values. Reciprocal Bin Widths are 6.10, unsigned, 16-bit, fixed-point values. Operation of this register is controlled by the host driver or the DSP (84 total entries) (undefined at reset).

[15:0] Bin Width Values, **BW[15:0]**[15:0] Reciprocal Bin Width Values, **RBW[15:0]**

ADV611/ADV612

PIN FUNCTION DESCRIPTIONS

Clock Pins

Name	Pins	I/O	Description
VCLK/XTAL	2	I	A single clock (VCLK) or crystal input (across VCLK and XTAL). An acceptable 50% duty cycle clock signal is 27 MHz (CCIR-601 NTSC/PAL). If using a clock crystal, use a parallel resonant, microprocessor grade clock crystal. If using a clock input, use a TTL level input, 50% duty cycle clock with 1 ns (or less) jitter (measured rising edge to rising edge). Slowly varying, low jitter clocks are acceptable; up to 5% frequency variation in 0.5 sec.
VCLKO	1	O	VCLK Output or VCLK Output divided by two. Select function using Mode Control register.

Video Interface Pins

Name	Pins	I/O	Description
VSYNC	1	I or O	Vertical Sync or Vertical Blank. This pin can be either an output (Master Mode) or an input (Slave Mode). The pin operates as follows: <ul style="list-style-type: none"> • Output (Master) HI during inactive lines of video and LO otherwise • Input (Slave) a HI on this input indicates inactive lines of video
HSYNC	1	I or O	Horizontal Sync or Horizontal Blank. This pin can be either an output (Master Mode) or an input (Slave Mode). The pin operates as follows: <ul style="list-style-type: none"> • Output (Master) HI during inactive portion of video line and LO otherwise • Input (Slave) a HI on this input indicates inactive portion of video line Note that the polarity of this signal is modified using the Mode Control register. For detailed timing information, see the Video Interface section.
FIELD	1	I or O	Field # or Frame Sync. Polarity of FIELD Pin can be reversed by setting Bit 3 in Mode Control Register 2. The pin operates as follows: <ul style="list-style-type: none"> • Output (Master) HI during Field1 lines of video and LO otherwise • Input (Slave) a HI on this input indicates Field1 lines of video
ENC	1	O	Encode or Decode. This output pin indicates the coding mode of the ADV611/ADV612 and operates as follows: <ul style="list-style-type: none"> • LO Decode Mode (Video Interface is output) • HI Encode Mode (Video Interface is input) Note that this pin can be used to control bus enable pins for devices connected to the ADV611/ADV612 Video Interface.
VDATA[7:0]	8	I/O	4:2:2 Video Data (8-bit digital component video data). These pins are inputs during encode mode and outputs during decode mode. When outputs (decode) these pins are compatible with 50 pF loads (rather than 30 pF as all other busses) to meet the high performance and large number of typical loads on this bus. The performance of these pins varies with the Video Interface Mode set in the Mode Control register, see the Video Interface section of this data sheet for pin assignments in each mode. Note that the Mode Control register also sets whether the color component is treated as either signed or unsigned.
STALL	1	I	Stall Mode. This pin stalls incoming video data driving encode.

DRAM Interface Pins

Name	Pins	I/O	Description
DDAT[15:0]	16	I/O	DRAM Data Bus. The ADV611/ADV612 uses these pins for 16-bit data read/write operations to the external 256K × 16-bit DRAM. (The operation of the DRAM interface is fully automatic and controlled by internal functionality of the ADV611/ADV612.) These pins are compatible with 30 pF loads.
DADR[8:0]	9	O	DRAM Address Bus. The ADV611/ADV612 uses these pins to form the multiplexed row/column address lines to the external DRAM. (The operation of the DRAM interface is fully automatic and controlled by internal functionality of the ADV611/ADV612.) These pins are compatible with 30 pF loads.
$\overline{\text{RAS}}$	1	O	DRAM Row Address Strobe. This pin is compatible with 30 pF loads.
$\overline{\text{CAS}}$	1	O	DRAM Column Address Strobe. This pin is compatible with 30 pF loads.
$\overline{\text{WE}}$	1	O	DRAM Write Enable. This pin is compatible with 30 pF loads. Note that the ADV611/ADV612 does not have a DRAM $\overline{\text{OE}}$ pin. Tie the DRAM's $\overline{\text{OE}}$ pin to ground.

Host Interface Pins

Name	Pins	I/O	Description																				
DATA[31:0]	32	I/O	Host Data Bus. These pins make up a 32-bit wide host data bus. The host controls this asynchronous bus with the $\overline{\text{WR}}$, $\overline{\text{RD}}$, $\overline{\text{BE}}$ and $\overline{\text{CS}}$ pins to communicate with the ADV611/ADV612. These pins are compatible with 30 pF loads.																				
ADR[1:0]	2	I	Host DWord Address Bus. These two address pins let you address the ADV611/ADV612's four directly addressable host interface registers. For an illustration of how this addressing works, see the Control and Write Register Map figure and Status and Read Register Map figure. The ADR bits permit register addressing as follows: <table style="margin-left: 20px; border-collapse: collapse;"> <tr> <td style="padding-right: 10px;">ADR1</td> <td style="padding-right: 10px;">ADR0</td> <td style="padding-right: 10px;">DWord</td> <td>Address Byte Address</td> </tr> <tr> <td>0</td> <td>0</td> <td>0</td> <td>0x00</td> </tr> <tr> <td>0</td> <td>1</td> <td>1</td> <td>0x04</td> </tr> <tr> <td>1</td> <td>0</td> <td>2</td> <td>0x08</td> </tr> <tr> <td>1</td> <td>1</td> <td>3</td> <td>0x0C</td> </tr> </table>	ADR1	ADR0	DWord	Address Byte Address	0	0	0	0x00	0	1	1	0x04	1	0	2	0x08	1	1	3	0x0C
ADR1	ADR0	DWord	Address Byte Address																				
0	0	0	0x00																				
0	1	1	0x04																				
1	0	2	0x08																				
1	1	3	0x0C																				
$\overline{\text{BE0}}\text{--}\overline{\text{BE1}}$ $\overline{\text{BE2}}\text{--}\overline{\text{BE3}}$	2	I	Host Word Enable pins. These two input pins select the words that the ADV611/ADV612's direct and indirect registers access through the Host Interface; $\overline{\text{BE0}}\text{--}\overline{\text{BE1}}$ access the least significant word, and $\overline{\text{BE2}}\text{--}\overline{\text{BE3}}$ access the most significant word. For a 32-bit interface only, tie these pins to ground, making all words available. Some important notes for 16-bit interfaces are as follows: <ul style="list-style-type: none"> • When using these byte enable pins, the byte order is always the lowest byte to the higher bytes. • The ADV611/ADV612 advances to the next 32-bit compressed data FIFO location after the $\overline{\text{BE2}}\text{--}\overline{\text{BE3}}$ pin is asserted then de-asserted (when accessing the Compressed Data register); so the FIFO location only advances when and if the host reads or writes the MSW of a FIFO location. • The ADV611/ADV612 advances to the next 16-bit indirect register after the $\overline{\text{BE0}}\text{--}\overline{\text{BE1}}$ pin is asserted then de-asserted; so the register selection only advances when and if the host reads or writes the MSW of a 16-bit indirect register. 																				
$\overline{\text{CS}}$	1	I	Host Chip Select. This pin operates as follows: <ul style="list-style-type: none"> • LO Qualifies Host Interface control signals • HI Three-states DATA[31:0] pins 																				
$\overline{\text{WR}}$	1	I	Host Write. Host register writes occur on the rising edge of this signal.																				
$\overline{\text{RD}}$	1	I	Host Read. Host register reads occur on the low true level of this signal.																				

ADV611/ADV612

Host Interface Pins (Continued)

Name	Pins	I/O	Description
$\overline{\text{ACK}}$	1	O	Host Acknowledge. The ADV611/ADV612 acknowledges completion of a Host Interface access by asserting this pin. Most Host Interface accesses (other than the compressed data register access) result in $\overline{\text{ACK}}$ being held high for at least one wait cycle, but some exceptions to that rule are as follows: <ul style="list-style-type: none"> A full FIFO during decode operations causes the ADV611/ADV612 to de-assert (drive HI) the $\overline{\text{ACK}}$ pin, holding off further writes of compressed data until the FIFO has one available location. An empty FIFO during encode operations causes the ADV611/ADV612 to de-assert (drive HI) the $\overline{\text{ACK}}$ pin, holding off further reads until one location is filled.
FIFO_SRQ	1	O	FIFO Service Request. This pin is an active high signal indicating that the FIFO needs to be serviced by the host. (see FIFO Control register). The state of this pin also appears in the Interrupt Mask/Status register. Use the interrupt mask to assert a Host interrupt ($\overline{\text{HIRQ}}$ pin) based on the state of the FIFO_SRQ pin. This pin operates as follows: <ul style="list-style-type: none"> LO No FIFO Service Request condition (FIFOSRQ bit LO) HI FIFO needs service is nearly full (encode) or nearly empty (decode) During encode, FIFO_SRQ is LO when the SWR bit is cleared (0) and goes HI when the FIFO is nearly full (see FIFO Control register). During decode, FIFO_SRQ is HI when the SWR bit is cleared (0), because FIFO is empty, and goes LO when the FIFO is filled beyond the nearly empty condition (see FIFO Control register).
STATS_R	1	O	Statistics Ready. This pin indicates the Wavelet Statistics (contents of Sum of Squares, Sum of Value, MIN Value, MAX Value registers) have been updated and are ready for the Bin Width calculator to read them from the host interface. The frequency of this interrupt will be equal to the field rate. The state of this pin also appears in the Interrupt Mask/Status register. Use the interrupt mask to assert a Host interrupt ($\overline{\text{HIRQ}}$ pin) based on the state of the STATS_R pin. This pin operates as follows: <ul style="list-style-type: none"> LO No Statistics Ready condition (STATSR bit LO) HI Statistics Ready for BW calculator (STATSR bit HI)
LCODE	1	O	Last Compressed Data (for field). This bit indicates the last compressed data word for field will be retrieved from the FIFO on the next read from the host bus. The frequency of this interrupt is similar to the field rate, but varies depending on compression and host response. The state of this pin also appears in the Interrupt Mask/Status register. Use the interrupt mask to assert a Host interrupt ($\overline{\text{HIRQ}}$ pin) based on the state of the LCODE pin. This pin operates as follows: <ul style="list-style-type: none"> LO No Last Code condition (LCODE bit LO) HI Last data word for field has been read from FIFO (LCODE bit HI)
$\overline{\text{HIRQ}}$	1	O	Host Interrupt Request. This pin indicates an interrupt request to the Host. The Interrupt Mask/Status register can select conditions for this interrupt based on any or all of the following: FIFOSTP, FIFOSRQ, FIFOERR, LCODE, STATR or CCIR-656 unrecoverable error. Note that the polarity of the $\overline{\text{HIRQ}}$ pin can be modified using the Mode Control register.
$\overline{\text{RESET}}$	1	I	ADV611/ADV612 Chip Reset. Asserting this pin returns all registers to reset state. Note that the ADV611/ADV612 must be reset at least once after power-up with this active low signal input. For more information on reset, see the SWR bit description.

Power Supply Pins

Name	Pins	I/O	Description
GND	16	I	Ground
VDD	13	I	+5 V dc Digital Power

Video Interface

The ADV611/ADV612 video interface supports two types of component digital video (D1) interfaces in both compression (input) and decompression (output) modes. These digital video interfaces include support for the Multiplexed Philips 4:2:2 and CCIR-656/SMPTE125M—international standard.

Video interface master and slave modes allow for the generation or receiving of synchronization and blanking signals. Definitions for the different formats can be found later in this section. For recommended connections to popular video decoders and encoders, see the Connecting the ADV611/ADV612 to Popular Video Decoders and Encoders section. A complete list of supported video interfaces and sampling rates is included in Table VI.

Table VI. Component Digital Video Interfaces

Name	Bits/ Component	Color Space	Sampling	Nominal Date Rate (MHz)	I/F Width
CCIR-656 Multiplex	8	YCrCb	4:2:2	27	8
Philips	8	YUV	4:2:2	27	8

Internally, the video interface translates all video formats to one consistent format to be passed to the wavelet kernel. This consistent internal video standard is 4:2:2 at 16 bits accuracy.

VITC and Closed Captioning Support

The video interface also supports the direct loss-less extraction of 90-bit VITC codes during encode and the insertion of VITC codes during decode. Closed Captioning data (found on active Video Line 21) is handled just as normal active video on an active scan line. As a result, no special dedicated support is necessary for Closed Captioning. The data rates for Closed Captioning data are low enough to ensure robust operation of this mechanism at compression ratios of 50:1 and higher. Note that you must include Video Line 21 in the ADV611/ADV612's defined active video area for Closed Caption support.

27 MHz Nominal Sampling

There is one clock input (VCLK) to support all internal processing elements. This is a 50% duty cycle signal and must be synchronous to the video data. Internally this clock is doubled using a phase locked loop to provide for a 54 MHz internal processing clock. The clock interface is a two pin interface that allows a crystal oscillator to be tied across the pins or a clock oscillator to drive one pin. The nominal clock rate for the video interface is 27 MHz. Note that the ADV611/ADV612 also supports a pixel rate of 13.5 MHz.

Video Interface and Modes

In all, there are seven programmable features that configure the video interface. These are:

- *Encode-Decode Control*

In addition to determining what functions the internal processing elements must perform, this control determines the direction of the video interface. In decode mode, the video interface outputs data. In encode mode, the interface receives data. The state of the control is reflected on the ENC pin.

This pin can be used as an enable input by external line drivers. This control is maintained by the host processor.

- *Master-Slave Control*

This control determines whether the ADV611/ADV612 generates or receives the VSYNC, HSYNC, and FIELD signals. In master mode, the ADV611/ADV612 generates these signals for external hardware synchronization. In slave mode, the ADV611/ADV612 receives these signals. Note that some video formats require the ADV611/ADV612 to operate in slave mode only. This control is maintained by the host processor.

- *525-625 (NTSC-PAL) Control*

This control determines whether the ADV611/ADV612 is operating on 525/NTSC video or 625/PAL video. This information is used when the ADV611/ADV612 is in master and decode modes so that the ADV611/ADV612 knows where and when to generate the HSYNC, VSYNC, and FIELD Pulses as well as when to insert the SAV and EAV time codes (for CCIR-656 only) in the data stream. This control is maintained by the host processor. Table VII shows how the 525-625 Control in the Mode Control register works.

Table VII. Square Pixel Control, 525-625 Control, and Video Formats

525-625 Control	Max Horizontal Size	Max Field Size	NTSC-PAL
0	720	243	CCIR-601 NTSC
1	720	288	CCIR-601 PAL

- *Bipolar/Unipolar Color Component*

This mode determines whether offsets are used on color components. In Philips mode, this control is usually set to Bipolar, since the color components are normal twos-complement signed values. In CCIR-656 mode, this control is set to Unipolar, since the color components are offset by 128. Note that it is likely the ADV611/ADV612 will function if this control is in the wrong state, but compression performance will be degraded. It is important to set this bit correctly.

- *Active Area Control*

Four registers HSTART (horizontal start), HEND (horizontal end), VSTART (vertical start) and VEND (vertical end) determine the active video area. The maximum active video area is 720 by 288 pixels for a single field.

- *Video Format*

This control determines the video format that is supported. In general, the goal of the various video formats is to support glueless interfaces to the wide variety of video formats peripheral components expect. This control is maintained by the host processor. Table VIII shows a synopsis of the supported video formats. Definitions of each format can be found later in this section. For Video Interface pins descriptions, see the Pin Function Descriptions.

ADV611/ADV612

Table VIII. Component Digital Video Formats

Name	Bit/ Component	Color Space	Sampling	Nominal Data Rate (MHz)	Master/ Slave	I/F Width	Format Number
CCIR-656	8	YCrCb	4:2:2	27	Master	8	0x0
Multiplex Philips	8	YUV	4:2:2	27	Either	8	0x2

Clocks and Strobes

All video data is synchronous to the video clock (VCLK). The rising edge of VCLK is used to clock all data into the ADV611/ADV612.

Synchronization and Blanking Pins

Three signals, which can be configured as inputs or outputs, are used for video frame and field horizontal synchronization and blanking. These signals are VSYNC, HSYNC, and FIELD.

VDATA Pins Functions With Differing Video Interface Formats

The functionality of the Video Interface pins depends on the current video format.

Video Formats—CCIR-656

The ADV611/ADV612 supports a glueless video interface to CCIR-656 devices when the Video Format is programmed to CCIR-656 mode. CCIR-656 requires that 4:2:2 data (8 bits per component) be multiplexed and transmitted over a single 8-bit physical interface. A 27 MHz clock is transmitted along with the data. This clock is synchronous with the data. The color space of CCIR-656 is YCrCb.

When in master mode, the CCIR-656 mode does not require any external synchronization or blanking signals to accompany digital video. Instead, CCIR-656 includes special time codes in the stream syntax that define horizontal blanking periods,

vertical blanking periods, and field synchronization (horizontal and vertical synchronization information can be derived). These time codes are called End-of-Active-Video (EAV) and Start-of-Active-Video (SAV). Each line of video has one EAV and one SAV time code. EAV and SAV have three bits of embedded information to define HSYNC, VSYNC and Field information as well as error detection and correction bits.

VCLK is driven with a 27 MHz, 50% duty cycle clock which is synchronous with the video data. Video data is clocked on the rising edge of the VCLK signal. When decoding, the VCLK signal is typically transmitted along with video data in the CCIR-656 physical interface.

Electrically, CCIR-656 specifies differential ECL levels to be used for all interfaces. The ADV611/ADV612, however, only supports unipolar, TTL logic thresholds. Systems designs that interface to strictly conforming CCIR-656 devices (especially when interfacing over long cable distances) must include ECL level shifters and line drivers.

The functionality of HSYNC, VSYNC and FIELD Pins is dependent on three programmable modes of the ADV611/ADV612: Master-Slave Control, Encode-Decode Control and 525-625 Control. Table X summarizes the functionality of these pins in various modes.

Table IX. CCIR-656 Master and Slave Modes HSYNC, VSYNC, and FIELD Functionality

HSYNC, VSYNC and FIELD Functionality for CCIR-656	Master Mode (HSYNC, VSYNC and FIELD Are Outputs)	Slave Mode (HSYNC, VSYNC and FIELD Are Inputs)
Encode Mode (video data is input to the chip)	Pins are driven to reflect the states of the received time codes: EAV and SAV. This functionality is independent of the state of the 525-625 mode control. An encoder is most likely to be in master mode.	These pins are used to control the blanking of video and sequencing (used with video decoders that do not conform to the correct number of samples per line [e.g., the Harris 8115]).
Decode Mode (video data is output from the chip)	Pins are output to the precise timing definitions for CCIR-656 interfaces. The state of the pins reflect the state of the EAV and SAV timing codes that are generated in the output video data. These definitions are different for 525 and 625 line systems. The ADV611/ADV612 completely manages the generation and timing of these pins.	Undefined—Use Master Mode

Table X. Philips Multiplexed Video Master and Slave Modes HSYNC, VSYNC, and FIELD Functionality

HSYNC, VSYNC and FIELD Functionality for Multiplexed Philips	Master Mode (HSYNC, VSYNC and FIELD Are Outputs)	Slave Mode (HSYNC, VSYNC and FIELD Are Inputs)
Encode Mode (video data is input to the chip)	The ADV611/ADV612 completely manages the generation and timing of these pins. The device driving the ADV611/ADV612 video interface must use these outputs to remain in sync with the ADV611/ADV612. It is expected that this combination of modes would not be used frequently.	These pins are used to control the blanking of video and sequencing.
Decode Mode (video data is output from the chip)	The ADV611/ADV612 completely manages the generation and timing of these pins.	These pins are used to control the blanking of video and sequencing.

Video Formats — Multiplexed Philips Video

The ADV611/ADV612 supports a hybrid mode of operation that is a cross between standard dual lane Philips and single lane CCIR-656. In this mode, video data is multiplexed in the same fashion in CCIR-656, but the values 0 and 255 are not reserved as signaling values. Instead, external HSYNC and VSYNC pins are used for signaling and video synchronization. VCLK may range up to 27 MHz.

VCLK is driven with up to a 27 MHz 50% duty cycle clock synchronous with the video data. Video data is clocked on the rising edge of the VCLK signal. The functionality of HSYNC, VSYNC, and FIELD pins is dependent on three programmable modes of the ADV611/ADV612; Master-Slave Control, Encode-Decode Control, and 525-625 Control. Table IX summarizes the functionality of these pins in various modes.

Video Formats—References

For more information on video interface standards, see the following reference texts.

- For the definition of CCIR-601:
1992 – *CCIR Recommendations RBT series Broadcasting Service (Television) Rec. 601-3 Encoding Parameters of digital television for studios*, page 35, September 15, 1992.
- For the definition of CCIR-656:
1992 – *CCIR Recommendations RBT series Broadcasting Service (Television) Rec. 656-1 Interfaces for digital component video signals in 525 and 626 line television systems operating at the 4:2:2 level of Rec. 601*, page 46, September 15, 1992.

Host Interface

The ADV611/ADV612 host interface is a high performance interface that passes all command and real-time compressed video data between the host and codec. A 512 position by 32-bit wide, bidirectional FIFO buffer passes compressed video data to and from the host. The host interface is capable of burst transfer rates of up to 132 million bytes per second (4 × 33 MHz). For host interface pins descriptions, see the Pin Function Descriptions section. For host interface timing information, see the Host Interface Timing section.

DRAM Manager

The DRAM Manager provides a sorting and reordering function on the subband coded data between the Wavelet Kernel and the Programmable Quantizer. The DRAM manager provides a pipeline delay stage to the ADV611/ADV612. This pipeline lets the ADV611/ADV612 extract current field image statistics (min/max pixel values, sum of pixel values, and sum of squares) used in the calculation of bin widths and reorder wavelet transform data. The use of current field statistics in the bin width calculation results in precise control over the compressed bit rate. The DRAM manager manages the entire operation and refresh of the DRAM.

The interface between the ADV611/ADV612 DRAM manager and DRAM is designed to be transparent to the user. The ADV611/ADV612 DRAM pins should be connected to the DRAM as called out in the Pin Function Descriptions section. The ADV611/ADV612 requires one 256K word by 16-bit, 60 ns DRAM. The following is a selected list of manufacturers and part numbers. All parts can be used with the ADV611/ADV612 at all VCLK. Any DRAM used with the ADV611/ADV612 must meet the minimum specifications outlined for the Hyper Mode DRAMs listed in Table XI. For DRAM Interface pins descriptions, see the Pin Function Descriptions.

Table XI. Compatible DRAMs

Manufacturer	Part Number	Notes
Toshiba	TC514265DJ/DZ/DFT-60	None
NEC	μPD424210ALE-60	None
NEC	μPD42S4210ALE-60	CBR Self-Refresh feature of this product is not needed by the ADV611/ADV612.
Hitachi	HM514265CJ-60	None

ADV611/ADV612

Compressed Data-Stream Definition

Through its Host Interface the ADV611/ADV612 outputs (during encode) and receives (during decode) compressed digital video data. This stream of data passing between the ADV611/ADV612 and the host is hierarchically structured and broken up into blocks of data as shown in Figure 13. Table V shows

pseudo code for a video data transfer that matches the transfer order shown in Figure 13 and uses the code names shown in Table XIV. The blocks of data listed in Figure 13 correspond to wavelet compressed sections of each field illustrated in Figure 13 as a modified Mallat diagram.

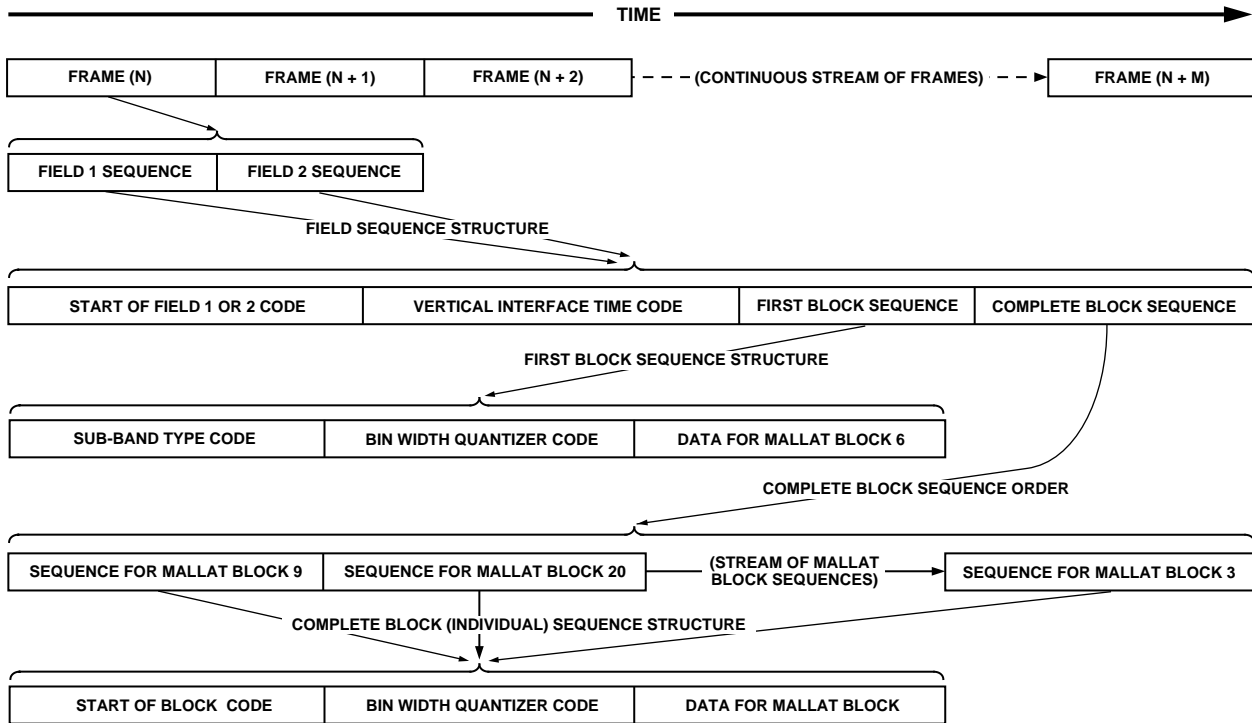

Figure 13. Hierarchical Structure of Wavelet Compressed Frame Data (Data Block Order)

Table XII. Pseudo-Code Describing a Sequence of Video Fields

Complete Sequence:	
<Field 1 Sequence>	“Frame N; Field 1”
<Field 2 Sequence>	“Frame N; Field 2”
<Field 1 Sequence>	“Frame N+1; Field 1”
<Field 2 Sequence>	“Frame N+1; Field 2”
(Field Sequences)	
<Field 1 Sequence>	“Frame N+M; Field 1”
<Field 2 Sequence>	“Frame N+M; Field 2”
#EOS	“Required in decode to let the ADV611/ADV612 know the sequence of fields is complete.”
Field 1 Sequence:	
#SOF1	
<VITC>	
<First Block Sequence>	
<Complete Block Sequence>	
Field 2 Sequence:	
#SOF2	
<VITC>	
<First Block Sequence>	
<Complete Block Sequence>	
First Block Sequence:	
<TYPE4>	
<BW>	
<Huff_Data>	
Complete Block Sequence:	
<Block Sequence>	
...	
(Block Sequences)	
...	
<Block Sequence>	
Block Sequence:	
#SOB1, #SOB2, #SOB3, #SOB4 or #SOB5	
<BW>	
<Huff_Data>	

ADV611/ADV612

In general, a Frame of data is made up of odd and even Fields as shown in Figure 13. Each Field Sequence is made up of a First Block Sequence and a Complete Block Sequence. The First Block Sequence is separate from the Complete Block Sequence. The Complete Block Sequence contains the remaining 41 Block Sequences (see block numbering in Figure 14). Each Block Sequence contains a start of block delimiter, Bin Width

for the block and actual encoder data for the block. A pseudo code bitstream example for one complete field of video is shown in Table XIII. A pseudo code bitstream example for one sequence of fields is shown in Table XIV. An example listing of a field of video in ADV611/ADV612 bitstream format appears in Table XVII.

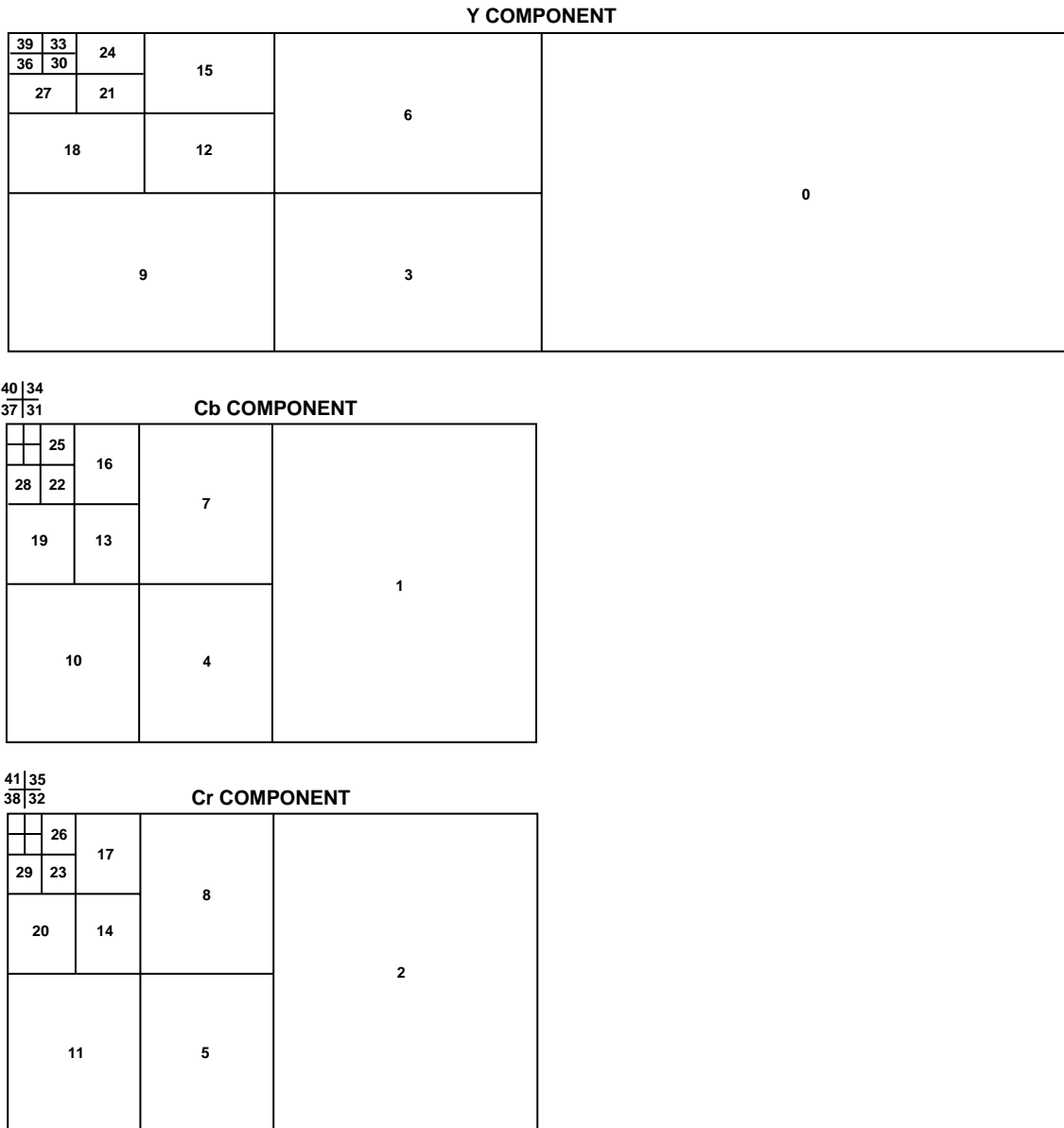

Figure 14. Block Order of Wavelet Compressed Field Data (Modified Mallat Diagram)

Table XIII. Pseudo Code of Compressed Video Data Bitstream for One Field of Video

Block Sequence Data	For Mallat Block Number . . .
#SOFn<VITC><TYPE4><BW><Huff_Data>	n indicates field 1 or 2 Huff_Data indicates Mallat block 6 data A typical Bin Width (BW) factor for this block is 0x1DDC
#SOB4<BW><Huff_Data>	Mallat block 9 data—Typical BW = 0x1DDC
#SOB3<BW><Huff_Data>	Mallat block 20 data—Typical BW = 0x0C2E
#SOB3<BW><Huff_Data>	Mallat block 22 data—Typical BW = 0x03A1
#SOB3<BW><Huff_Data>	Mallat block 19 data—Typical BW = 0x0C2E
#SOB3<BW><Huff_Data>	Mallat block 23 data—Typical BW = 0x03A1
#SOB3<BW><Huff_Data>	Mallat block 17 data—Typical BW = 0x0C2E
#SOB3<BW><Huff_Data>	Mallat block 25 data—Typical BW = 0x0306
#SOB3<BW><Huff_Data>	Mallat block 16 data—Typical BW = 0x0C2E
#SOB3<BW><Huff_Data>	Mallat block 26 data—Typical BW = 0x0306
#SOB3<BW><Huff_Data>	Mallat block 14 data—Typical BW = 0x0E9D
#SOB3<BW><Huff_Data>	Mallat block 28 data—Typical BW = 0x0306
#SOB3<BW><Huff_Data>	Mallat block 13 data—Typical BW = 0x0E9D
#SOB3<BW><Huff_Data>	Mallat block 29 data—Typical BW = 0x0306
#SOB3<BW><Huff_Data>	Mallat block 11 data—Typical BW = 0x2410
#SOB1<BW><Huff_Data>	Mallat block 31 data—Typical BW = 0x0114
#SOB3<BW><Huff_Data>	Mallat block 10 data—Typical BW = 0x2410
#SOB1<BW><Huff_Data>	Mallat block 32 data—Typical BW = 0x0114
#SOB3<BW><Huff_Data>	Mallat block 8 data—Typical BW = 0x2410
#SOB1<BW><Huff_Data>	Mallat block 34 data—Typical BW = 0x00E5
#SOB3<BW><Huff_Data>	Mallat block 7 data—Typical BW = 0x2410
#SOB1<BW><Huff_Data>	Mallat block 35 data—Typical BW = 0x00E6
#SOB3<BW><Huff_Data>	Mallat block 5 data—Typical BW = 0x2B46
#SOB1<BW><Huff_Data>	Mallat block 37 data—Typical BW = 0x00E6
#SOB3<BW><Huff_Data>	Mallat block 4 data—Typical BW = 0x2B46
#SOB1<BW><Huff_Data>	Mallat block 38 data—Typical BW = 0x00E6
#SOB3<BW><Huff_Data>	Mallat block 2 data—Typical BW = 0xC62B
#SOB1<BW><Huff_Data>	Mallat block 40 data—Typical BW = 0x009A
#SOB3<BW><Huff_Data>	Mallat block 1 data—Typical BW = 0xC62B
#SOB1<BW><Huff_Data>	Mallat block 41 data—Typical BW = 0x009A
#SOB4<BW><Huff_Data>	Mallat block 0 data—Typical BW = 0xA417
#SOB2<BW><Huff_Data>	Mallat block 39 data—Typical BW = 0x007F
#SOB4<BW><Huff_Data>	Mallat block 12 data—Typical BW = 0x0C1A
#SOB2<BW><Huff_Data>	Mallat block 36 data—Typical BW = 0x00BE
#SOB4<BW><Huff_Data>	Mallat block 15 data—Typical BW = 0x0A16
#SOB2<BW><Huff_Data>	Mallat block 33 data—Typical BW = 0x00BE
#SOB4<BW><Huff_Data>	Mallat block 18 data—Typical BW = 0x0A16
#SOB2<BW><Huff_Data>	Mallat block 30 data—Typical BW = 0x00E4
#SOB2<BW><Huff_Data>	Mallat block 21 data—Typical BW = 0x0301
#SOB2<BW><Huff_Data>	Mallat block 27 data—Typical BW = 0x0281
#SOB2<BW><Huff_Data>	Mallat block 24 data—Typical BW = 0x0281
#SOB4<BW><Huff_Data>	Mallat block 3 data—Typical BW = 0x23D5

Table XIV specifies the Mallat block transfer order and associated Start of Block (SOB) codes. Any of these SOB codes can be replaced with an SOB#5 code for a zero data block.

Table XIV. Pseudo Code of Compressed Video Data Bitstream for One Sequence of Video Fields

Block Sequence Data	For Mallat Block Number
#SOF1<VITC><TYPE4><BW><Huff_Data> ... (41 #SOBn blocks)	/* Mallat block 6 data */
#SOF2<VITC><TYPE4><BW><Huff_Data> ... (41 #SOBn blocks) . (any number of Fields in sequence)	/* Mallat block 6 data */
#EOS	/* Required in decode to end field sequence*/

ADV611/ADV612

Table XV. ADV611/ADV612 Field and Block Delimiters (Codes)

Code Name	Code	Description (Align all #Delimiter Codes to 32-Bit Boundaries)
#SOF1	0xffffffff40000000	Start of Field delimiter identifies Field1 data. #SOF1 resets the Huffman decoder and is sufficient on its own to reset the processing of the chip during decode. Please note that this code or #SOF2 are the only delimiters necessary between adjacent fields. #SOF1 operates identically to #SOF2 except that during decode it can be used to differentiate between Field1 and Field2 in the generation of the Field signal (master mode) and/or SAV/EAV codes for CCIR-656 modes.
#SOF2	0xffffffff41000000	Start of Field delimiter identifies Field2 data. #SOF resets the Huffman decoder and is sufficient on its own to reset the processing of the chip during decode. Please note that this code or #SOF1 are the only delimiters necessary between adjacent fields. #SOF2 operates identically to #SOF1 except that during decode it can be used to differentiate between Field2 and Field1 in the generation of the Field signal (master mode) and/or SAV/EAV codes for CCIR-656 modes.
<VITC>	(96 bits)	This is a 12-byte string of data extracted by the video interface during encode operations and inserted by the video interface into the video data during decode operations. The data content is 90 bits in length. For a complete description of VITC format, see pages 175-178 of Video Demystified: A Handbook For The Digital Engineer (listed in References section).
<TYPE1>	0x81	This is an 8-bit delimiter-less type code for the first subband block of wavelet data. (Model 1 Chroma)
<TYPE2>	0x82	This is an 8-bit delimiter-less type code for the first subband block of wavelet data. (Model 1 Luma)
<TYPE3>	0x83	This is an 8-bit delimiter-less type code for the first subband block of wavelet data. (Model 2 Chroma)
<TYPE4>	0x84	This is an 8-bit delimiter-less type code for the first subband block of wavelet data. (Model 2 Luma)
#SOB1	0xffffffff81	Start of Block delimiter identifies the start of Huffman coded subband data. This delimiter will reset the Huffman decoder if a system ever experiences bit errors or gets out of sync. The order of blocks in the frame is fixed and therefore implied in the bit stream and no unique #SOB delimiters are needed per block. There are 41 #SOB delimiters and associated BW and Huffman data within a field. #SOB1 is differentiated from #SOB2, #SOB3 and #SOB4 in that they indicate which model and Huffman table was used in the Run Length Coder for the particular block: #SOB1 Model 1 Chroma #SOB2 Model 1 Luma #SOB3 Model 2 Chroma #SOB4 Model 2 Luma #SOB5 Zero data block. All data after this delimiter and before the next start of block delimiter is ignored (if present at all) and assumed zero including the BW value.
#SOB2	0xffffffff82	
#SOB3	0xffffffff83	
#SOB4	0xffffffff84	
#SOB5	0xffffffff8f	
<BW>	(16 bits, 8.8)	This data code is not entropy coded, is always 16 bits in length and defines the Bin Width Quantizer control used on all data in the block subband. During decode, this value is used by the Quantizer. If this value is set to zero during decode, all Huffman data is presumed to be zero and is ignored, but must be included. During encode, this value is calculated by the external Host and is inserted into the bitstream by the ADV611/ADV612 (this value is not used by the quantizer). Another value calculated by the Host, 1/BW is actually used by the Quantizer during encode.
<HUFF_DATA>	(Modulo 32)	This data is the quantized and entropy coded block subband data. The data's length is dependent on block size and entropy coding so it is therefore variable in length. This field is filled with 1s making it Modulo 32 bits in length. Any Huffman decode process can be interrupted and reset by any unexpectedly received # delimiter following a bit error or synchronization problem.
#EOS	0xffffffffc0ffffff	The host sends the #EOS (End of Sequence) to the ADV611/ADV612 during decode after the last field in a sequence to indicate that the field sequence is complete. The ADV611/ADV612 does not append this code to the end of encoded field sequences; it must be added by the host.

Table XVI. Video Data Bitstream for One Field In a Video Sequence¹

ffff	ffff	4000	0000	0000	0000	0000	0000	0000	0000	8400	00ff	df0d	8eff	ffff	ffff
8400	00ff	df0c	daff	ffff	ffff	8300	00ff	609f	ffff	ffff	ffff	8300	00fe	c5af	ffff
ffff	ffff	8300	00ff	609f	ffff	ffff	ffff	8300	00fe	c5af	ffff	ffff	ffff	8300	00ff
609f	ffff	ffff	ffff	8300	00fe	c70f	ffff	ffff	ffff	8300	00ff	609f	ffff	ffff	ffff
8300	00fe	c70f	ffff	ffff	ffff	8300	00ff	609f	ffff	ffff	ffff	8300	00fe	c78f	ffff
ffff	ffff	8300	00ff	609f	ffff	ffff	ffff	8300	00fe	c78f	ffff	ffff	ffff	8300	00ff
6894	3fff	ffff	ffff	811d	40f0	90ff	ffff	ffff	ffff	8300	00ff	6894	3fff	ffff	ffff
811d	40f0	90ff	ffff	ffff	ffff	8300	00ff	68aa	bfff	ffff	ffff	8116	80f0	9bff	ffff
ffff	ffff	8300	00ff	68aa	bfff	ffff	ffff	8116	80f0	9bff	ffff	ffff	ffff	8300	00ff
6894	3fff	ffff	ffff	8116	80f0	9fff	ffff	ffff	ffff	8300	00ff	6894	3fff	ffff	ffff
8116	80f0	9fff	ffff	ffff	ffff	8300	00ff	fe62	a2ff	ffff	ffff	8103	e6e9	d74d	75d7
5d75	d75a	f8f9	74eb	d7af	5ebd	7af5	ebf0	f8f8	f979	7979	7979	7979	79fd	5f5f	c7e3
f1f8	fc7e	3f1f	8fc7	e5fa	ff6f	d5f6	7d9f	67d9	f67d	9f67	d9f6	7edf	abec	f87c	3e1f
0f87	c3e1	f0f8	fd9f	1f1f	2f2f	2f2f	2f2f	2f2f	2f1f	2ebd	7af5	ebd7	ae9d	74e9	a56d
6b5a	d6b5	a2b0	d249	24a5	ce36	db6d	b6db	6db7	c6fd	fd3d	3d3d	3d3d	3d3d	3d3b	7a7b
fbfb	fbfb	fbfb	fbfb	fcfd	bdfe	dfb7	edfb	7eef	bbee	fbbe	dfbb	dbe7	f6fd	ff7f	dff7
fdff	7fdf	f7fd	feff	3fbb	effb	feff	bfef	fbfe	ffbf	efff	ffff	ffff	ffff	8300	00ff
fe62	a2ff	ffff	ffff	8103	e6fd	bfab	f9bf	57d5	f2eb	18f4	f9fd	ffb7	f5ff	3feb	fafc
7431	e9f4	fbff	77eb	fd3f	b3ec	f2d5	efeb	f6fe	1fbb	f67e	afdb	f0f3	aaed	edf7	fe3f
57ed	fd7f	bbe3	d2d3	dfe7	f87e	5f57	eedf	9fbb	e5d6	2fdf	e7f8	7eff	abf7	7ecf	ddf2
eb17	eff3	fc3f	7fd5	fbfb	67ee	f975	8bf7	f9fe	1fbf	ea fd	dfb3	f77c	bac5	fbfc	ff0f
dff5	7eef	d9fb	be5d	62fd	fe7f	87ef	fabf	77ec	fddf	2eb1	7eff	3fc3	f7fd	5fbb	f67e
ef97	58bf	7f9f	e1fb	feaf	ddf3	3f77	cbac	5fbf	cdf0	fdff	57ee	fd9f	bbe5	d62f	dfe7
f87e	ffaaf	f77e	cfab	e5d6	2fe9	f3fc	7f7f	d9f5	7edf	abc7	431e	9f4f	c7f8	7fff	fff
ffff	ffff	8400	00ff	dfb7	c5ff	df0d	7fff	ffff	ffff	8202	9afc	3eff	b7e9	ede9	e9e9
e9e9	e9e9	e9e9	e9e9	e9e9	e9e9	e9e9	dbef	fbbe	9efe	9dbb	76ed	dbb7	6edd	bb76	eddb
b76e	ddb7	fbbe	df9f	af6d	b6db	6db6	db6d	b6db	6db6	db6d	aff6	fd3d	bbed	7bde	f7bd
ef7b	def7	bdef	75f4	f7f4	dee9	2492	4924	924c	fa7b	77da	6991	f4f7	efb4	d323	e9ed
df69	a647	d3db	bed3	4c8f	a7b7	7da6	991f	4f7e	fb4d	323e	9edd	f69a	647d	3dbb	ed34
c8fa	7b77	da69	647c	fd7b	6100	0000	0045	bdfd	37bb	8888	8888	8888	8888	8aff	ffff
ffff	ffff	8400	00ff	c9a7	1fff	ffff	ffff	820f	00ff	7704	4fff	ffff	ffff	8400	00ff
c9a7	1fff	ffff	ffff	820f	00ff	7704	bfff	ffff	ffff	8400	00ff	c9a7	1fff	ffff	ffff
8213	80ff	7703	5fff	ffff	ffff	8200	00ff	7743	1fff	ffff	ffff	8200	00ff	7743	1fff
ffff	ffff	8200	00ff	7745	efff	ffff	ffff	8400	00ff	df0c	daff				

NOTE

¹This table shows ADV611/ADV612 compressed data for one field in a color ramp video sequence. The SOF# and SOB# codes in the data are in **bold** text.

Bit Error Tolerance

Bit error tolerance is ensured because a bit error within a Huffman coded stream does not cause #delimiter symbols to be misread by the ADV611/ADV612 in decode mode. The worst

error that can occur is loss of a complete block of Huffman data. With the ADV611/ADV612, this type of error results only in some blurring of the decoded image, not complete loss of the image.

ADV611/ADV612

APPLYING THE ADV611/ADV612

This section includes the following topics:

- Using the ADV611/ADV612 in computer applications
- Using the ADV611/ADV612 in stand-alone applications
- Configuring the host interface for 16- or 32-bit data paths
- Connecting the video interface to popular video encoders and decoders
- Getting the most out of the ADV611/ADV612

The following Analog Devices products should be considered in ADV611/ADV612 designs:

- ADV7175/ADV7176—Digital YUV to analog composite video encoder
- AD722—Analog RGB to analog composite video encoder
- AD1843—Audio codec with embedded video synchronization
- ADSP-21xx—Family of fixed-point digital signal processors
- AD8xxx—Family of video operational amplifiers

Using the ADV611/ADV612 in Computer Applications

Many key features of the ADV611/ADV612 were driven by the demanding cost and performance requirements of computer applications. The following ADV611/ADV612 features provide key advantages in computer applications, such as the one in Figure 15.

- *Host Interface*
The 512 double word FIFO provides necessary buffering of compressed digital video to deal with PCI bus latency.
- *Low Cost External DRAM*
Unlike many other real-time compression solutions, the ADV611/ADV612 does not require expensive external SRAM transform buffers or VRAM frame stores.

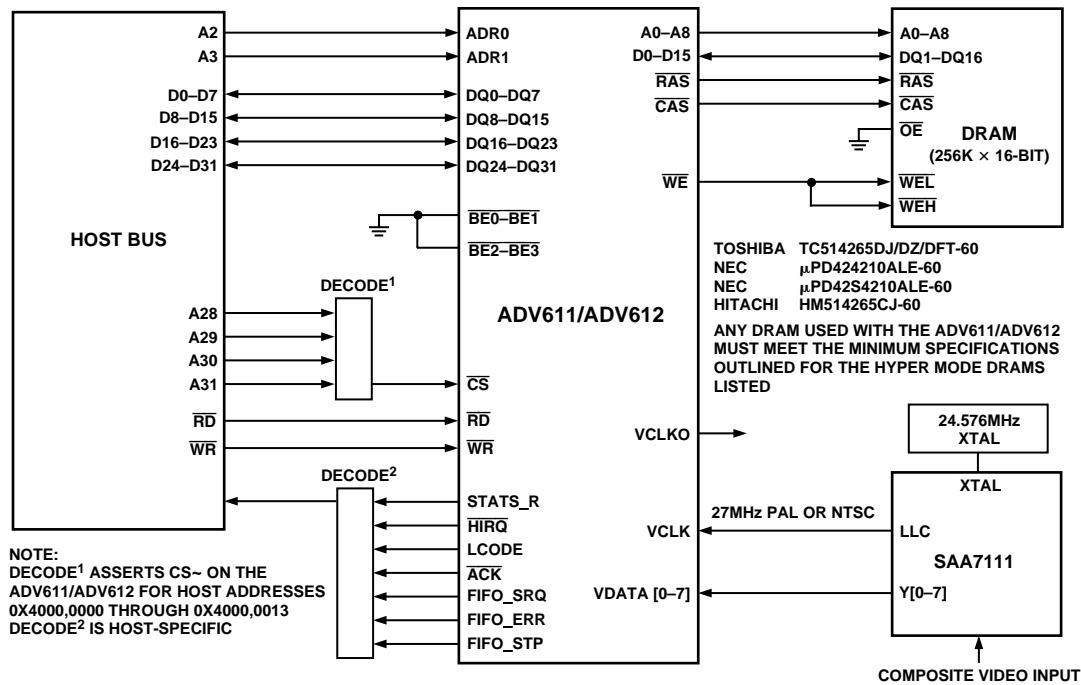

Figure 15. A Suggested PC Application Design

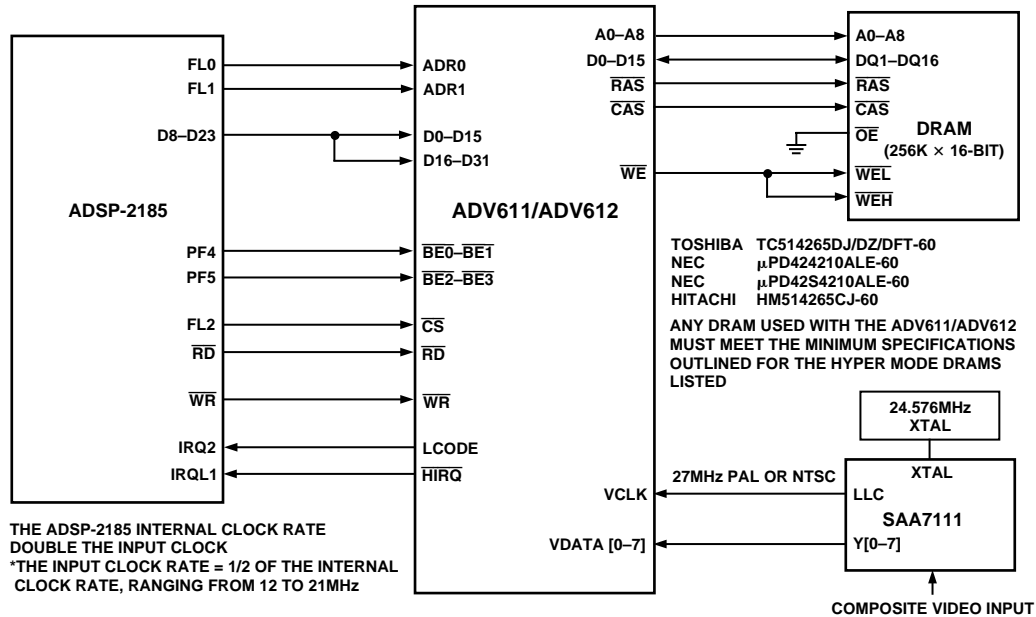

Figure 16. Alternate Stand-Alone Application Design

Using the ADV611/ADV612 In Stand-Alone Applications

Figure 16 shows the ADV611/ADV612 in a noncomputer based applications. Here, an ADSP-2185 digital signal processor provides Host control and BW calculation services. Note that all control and BW operations occur over the host interface in this design.

Connecting the ADV611/ADV612 to Popular Video Decoders and Encoders

The following circuits are recommendations only. Analog Devices has not actually built or tested these circuits.

Using the Philips SAA7111 Video Decoder

The SAA7111 example circuit, which appears in Figure 17, is used in this configuration on the ADV611 CCTVPIPE demonstration board.

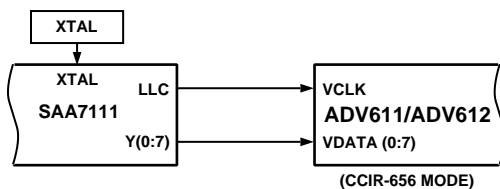

Figure 17. ADV611/ADV612 and SAA7111 Example Interfacing Block Diagram

Using the Analog Devices ADV7175 Video Encoder

Because the ADV7175 has a CCIR-656 interface, it connects directly with the ADV611/ADV612 without “glue” logic. Note that the ADV7175 can only be used at CCIR-601 sampling rates.

The ADV7175 example circuit, which appears in Figure 18, is used in this configuration on the ADV611 CCTVPIPE demonstration board.

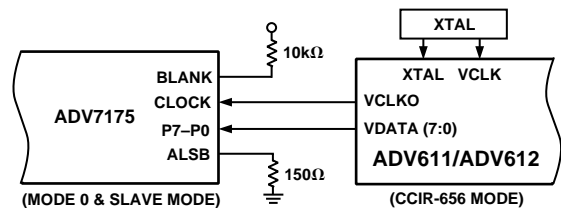

Figure 18. ADV611/ADV612 and ADV7175 Example Interfacing Block Diagram

Using the Raytheon TMC22153 Video Decoder

Raytheon has a whole family of video parts. Any member of the family can be used. The user must select the part needed based on the requirements of the application. Because the Raytheon part does not include the A/Ds, an external A/D is necessary in this design (or a pair of A/Ds for S video).

The part can be used in CCIR-656 (D1) mode for a zero control signal interface. Special attention must be paid to the video output modes in order to get the right data to the right pins (see the following diagram).

Note that the circuit in Figure 19 has not been built or tested.

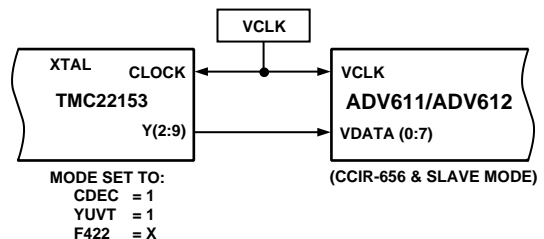

Figure 19. ADV611/ADV612 and TMC22153 Example CCIR-656 Mode Interface

ADV611/ADV612

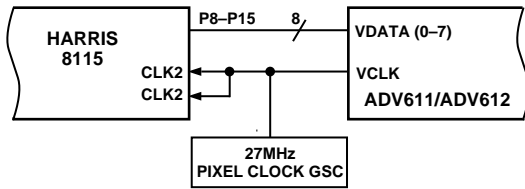

Figure 20. Using the Harris 8115 Decoder

GETTING THE MOST OUT OF ADV611/ADV612

How Much Compression Can Be Expected

The ADV611/ADV612 can be used in applications where up to 7500:1 compression is required. To express this in more meaningful terms, a digitized NTSC video signal at 167 MBit/s per second can be reduced to less than 25 kbits per second. To achieve this performance, the following approach could be used:

1. Image Compressed to 250:1
2. Frame Rate Reduced to 1 frame per second (not uncommon in CCTV applications)
3. Quality box size less than 1% of the total image size
4. Background contrast attenuated by 18 dB

The scenario described above used by Analog Devices on the CCTVPIPE evaluation board as the splash-screen after power-up. Video quality is subjective, and therefore, it is highly recommended to perform a direct evaluation of the CCTVPIPE or the ADV601 software codec to confirm that the compression performance is appropriate for a given application.

While the ADV611/ADV612 can be used in very high compression applications as outlined above, it is equally suitable for full resolution, 60 field per second visually loss-less applications.

Evaluation Board

There is a low cost stand-alone evaluation board for the ADV611 called the CCTVPIPE (see block diagram). The CCTVPIPE provides a fast, simple, and low cost means of evaluating the performance of the ADV611/ADV612 and it is very similar to the evaluation board for the ADV601LC, the VideoPipe. The CCTVPIPE is shipped with a small mouse to allow real-time quality box control. The board is also shipped with a small speaker to provide an audio alert signal when motion is detected in the video image. All of the source code and schematics for the CCTVPIPE are available from the Analog Devices Web site free of charge (www.analog.com/wavelet).

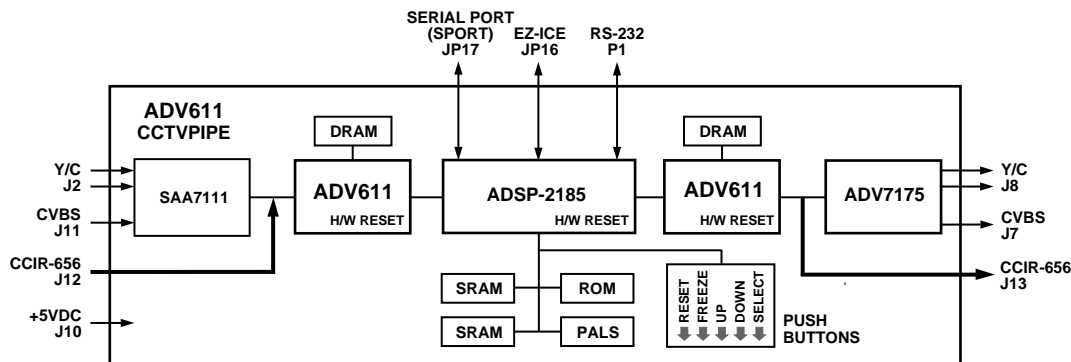

Figure 21. ADV611 CCTVPIPE Block Diagram

The exact part number is ADV611-CCTVPIPE and it can be purchased through any Analog Devices authorized sales channel.

A PCI card is available for the ADV601 called the "VideoLab," which is bitstream compatible with the ADV611/ADV612. See the Analog Devices Web site for further details.

Software Codec

Analog Devices has created two types of software products for cases where encoding or decoding in software are desirable.

- **Bit Exact Codec** – Nonreal-time bit exact encoder for Windows[®] '95 or '98.
- **MMX/DirectShow Player** – Real-time playback for Windows '98 (PC monitor can be used to view the video directly—no need for a dedicated TV monitor).

Field Rate Reduction

As demonstrated by the CCTVPIPE evaluation board, field rates can be reduced to increase compression. The ADV611/ADV612 allow this to be done in hardware (see register descriptions).

Edge Enhancement and Detection

Since the ADV611/ADV612 filters the image into wavelet subbands, edge information is isolated in the high pass blocks of image data (see the Mallat diagram of the Analog Devices building in the ADV601LC data sheet for an illustration). By zeroing the low pass blocks, the ADV611/ADV612 will preserve only the high pass content of the image and thus enhance the edges in the image. The CCTVPIPE has a mode that demonstrates this feature. Furthermore, these blocks can be Huffman decoded and analyzed for edge detection purposes.

Motion Detection

There are two known means of implementing motion detection with the ADV611/ADV612.

1. Compare the image statistics between fields of video. This is the technique used on the CCTVPIPE for the motion detection demo.
2. Decode the smallest Mallat block (Block 39) and compare one field to the next. Since these block are small (approximately 2400 pixels) the computational burden is much less than it would be for the entire image. For comparative purposes, the data samples in Block 39 contain only 1/1024th of the total samples, or 1/512th the luminance samples. Please Contact Analog Device, Inc. for information on how to implement this technique with quality box placement.

SPECIFICATIONS

ADV611/ADV612

The ADV611/ADV612 Video Codec uses a Bi-Orthogonal (7, 9) Wavelet Transform.

RECOMMENDED OPERATING CONDITIONS

Parameter	Description	Min	Max	Unit
V _{DD}	Supply Voltage	4.50	5.50	V
T _{AMB}	Ambient Operating Temperature	0	+70	°C

ELECTRICAL CHARACTERISTICS

Parameter	Description	Test Conditions	Min	Max	Unit
V _{IH}	Hi-Level Input Voltage	@ V _{DD} = max	2.0	N/A	V
V _{IL}	Lo-Level Input Voltage	@ V _{DD} = min	N/A	0.8	V
V _{OH}	Hi-Level Output Voltage	@ V _{DD} = min, I _{OH} = -0.5 mA	2.4	N/A	V
V _{OL}	Lo-Level Output Voltage	@ V _{DD} = min, I _{OL} = 2 mA	N/A	0.4	V
I _{IH}	Hi-Level Input Current	@ V _{DD} = max, V _{IN} = V _{DD} max	N/A	10	μA
I _{IL}	Lo-Level Input Current	@ V _{DD} = max, V _{IN} = 0 V	N/A	10	μA
I _{OZH}	Three-State Leakage Current	@ V _{DD} = max, V _{IN} = V _{DD} max	N/A	10	μA
I _{OZL}	Three-State Leakage Current	@ V _{DD} = max, V _{IN} = 0 V	N/A	10	μA
C _I	Input Pin Capacitance	@ V _{IN} = 2.5 V, f _{IN} = 1.0 MHz, T _{AMB} = +25°C	N/A	8*	pF
C _O	Output Pin Capacitance	@ V _{IN} = 2.5 V, f _{IN} = 1.0 MHz, T _{AMB} = +25°C	N/A	8*	pF

*Guaranteed but not tested.

ABSOLUTE MAXIMUM RATINGS*

Parameter	Description	Min	Max	Unit
V _{DD}	Supply Voltage	-0.3	+7	V
V _{IN}	Input Voltage	N/A	V _{DD} ± 0.3	V
V _{OUT}	Output Voltage	N/A	V _{DD} ± 0.3	V
T _{AMB} (ADV611)	Ambient Operating Temperature	0	+70	°C
T _{AMB} (ADV612)	Ambient Operating Temperature	-25	+85	°C
T _S	Storage Temperature	-65	+150	°C
T _L	Lead Temperature (5 sec) PQFP	N/A	+280	°C

*Stresses greater than those listed above under Absolute Maximum Ratings may cause permanent damage to the device. This is a stress rating only; functional operation of the device at these or any other conditions above those indicated in the Pin Definitions section of this specification is not implied. Exposure to maximum rating conditions for extended periods may affect device reliability.

SUPPLY CURRENT AND POWER

Parameter	Description	Test Conditions	Min	Max	Unit
I _{DD}	Supply Current (Dynamic)	@ V _{DD} = max, t _{VCLK_CYC} = 37 ns (at 27 MHz VCLK)	0.11	0.27	A
I _{DD}	Supply Current (Soft Reset)	@ V _{DD} = max, t _{VCLK_CYC} = 37 ns (at 27 MHz VCLK)	0.08	0.17	A
I _{DD}	Supply Current (Idle)	@ V _{DD} = max, t _{VCLK_CYC} = None	0.01	0.02	A

ENVIRONMENTAL CONDITIONS

Parameter	Description	ADV611/ADV612 Max	Unit
θ _{CA}	Case-to-Ambient Thermal Resistance	30	°C/W
θ _{JA}	Junction-to-Ambient Thermal Resistance	35	°C/W
θ _{JC}	Junction-to-Case Thermal Resistance	5	°C/W

CAUTION

The ADV611/ADV612 is an ESD (electrostatic discharge) sensitive device. Electrostatic charges readily accumulate on the human body and equipment and can discharge without detection. Permanent damage may occur to devices subjected to high energy electrostatic discharges. Proper ESD precautions are strongly recommended to avoid functional damage or performance degradation. The ADV611/ADV612 latchup immunity has been demonstrated at ≥200 mA/-200 mA on all pins when tested to industry standard/JEDEC methods.



ADV611/ADV612

TEST CONDITIONS

Figure 22 shows test condition voltage reference and device loading information. These test conditions consider an output as *disabled* when the output stops driving and goes from the measured high or low voltage to a high impedance state. Tests measure output disable time (t_{DISABLE}) as the time between the reference input signal crossing +1.5 V and the time that the

output reaches the high impedance state (also +1.5 V). Similarly, these tests conditions consider an output as *enabled* when the output leaves the high impedance state and begins driving a measured high or low voltage. Tests measure output enable time (t_{ENABLE}) as the time between the reference input signal crossing +1.5 V and the time that the output reaches the measured high or low voltage.

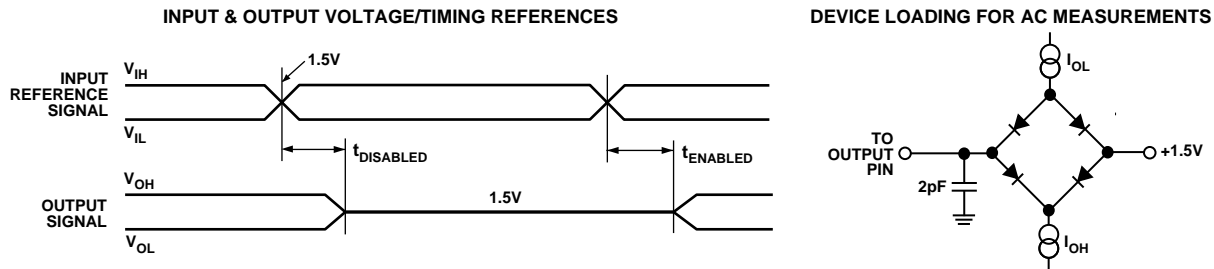

Figure 22. Test Condition Voltage Reference and Device Loading

TIMING PARAMETERS

This section contains signal timing information for the ADV611/ADV612. Timing descriptions for the following items appear in this section:

- Clock signal timing
- Video data transfer timing (CCIR-656, and Multiplexed Philips formats)
- Host data transfer timing (direct register read/write access)

Clock Signal Timing

The diagram in this section shows timing for VCLK input and VCLKO output. All output values assume a maximum pin loading of 50 pF.

Table XVII. Video Clock Period, Frequency, Drift and Jitter

Video Format	Min VCLK_CYC Period	Nominal VCLK_CYC Period (Frequency)	Max VCLK_CYC Period ^{1,2}
CCIR-601 PAL	35.2 ns	37 ns (27 MHz)	38.9 ns
CCIR-601 NTSC	35.2 ns	37 ns (27 MHz)	38.9 ns

NOTES

¹VCLK Period Drift = ± 0.1 (VCLK_CYC/field).

²VCLK edge-to-edge jitter = 1 ns.

Table XVIII. Video Clock Duty Cycle

	Min	Nominal	Max
VCLK Duty Cycle ¹	(40%)	(50%)	(60%)

NOTE

¹VCLK Duty Cycle = $t_{\text{VCLK_HI}} / (t_{\text{VCLK_LO}}) \times 100$.

Table XIX. Video Clock Timing Parameters

Parameter	Description	Min	Max	Unit
$t_{\text{VCLK_CYC}}$	VCLK Signal, Cycle Time (1/Frequency) at 27 MHz	(See Video Clock Period Table)		
$t_{\text{VCLKO_D0}}$	VCLKO Signal, Delay (when VCLK2 = 0) at 27 MHz	10	29	ns
$t_{\text{VCLKO_D1}}$	VCLKO Signal, Delay (when VCLK2 = 1) at 27 MHz	10	29	ns

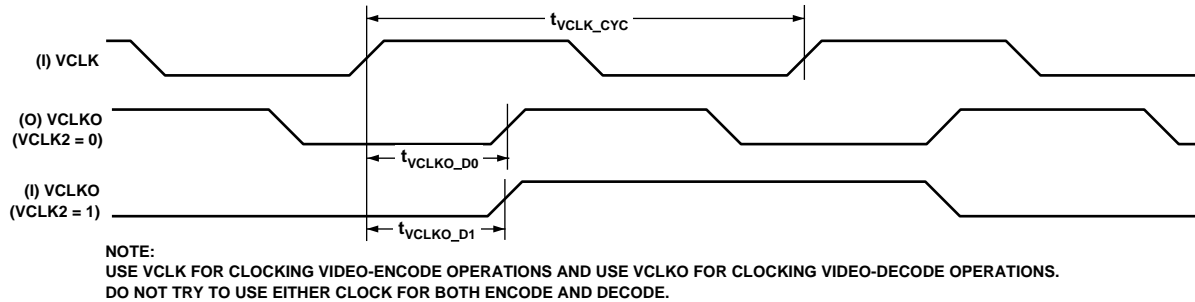

Figure 23. Video Clock Timing

CCIR-656 Video Format Timing

The diagrams in this section show transfer timing for pixel (YCrCb), line (horizontal), and frame (vertical) data in CCIR-656 video mode. All output values assume a maximum pin loading of 50 pF. Note that in timing diagrams for CCIR-656 video, the label *CTRL* indicates the VSYNC, HSYNC, and FIELD pins.

Table XX. CCIR-656 Video—Decode Pixel (YCrCb) Timing Parameters

Parameter	Description	Min	Max	Units
$t_{VDATA_DC_D}$	VDATA Signals, Decode CCIR-656 Mode, Delay	N/A	14	ns
$t_{VDATA_DC_OH}$	VDATA Signals, Decode CCIR-656 Mode, Output Hold	4	N/A	ns
$t_{CTRL_DC_D}$	CTRL Signals, Decode CCIR-656 Mode, Delay	N/A	11	ns
$t_{CTRL_DC_OH}$	CTRL Signals, Decode CCIR-656 Mode, Output Hold	5	N/A	ns

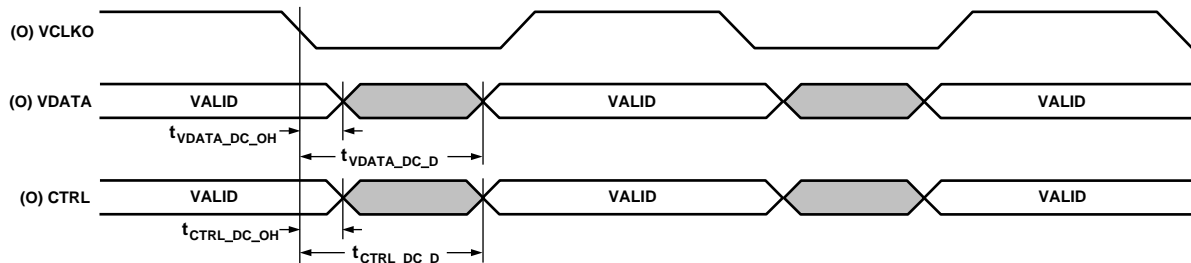

Figure 24. CCIR-656 Video—Decode Pixel (YCrCb) Transfer Timing

Table XXI. CCIR-656 Video—Encode Pixel (YCrCb) Timing Parameters

Parameter	Description	Min	Max	Units
$t_{VDATA_EC_S}$	VDATA Bus, Encode CCIR-656 Mode, Setup	2	N/A	ns
$t_{VDATA_EC_H}$	VDATA Bus, Encode CCIR-656 Mode, Hold	5	N/A	ns
$t_{CTRL_EC_D}$	CTRL Signals, Encode CCIR-656 Mode, Delay	N/A	33	ns
$t_{CTRL_EC_OH}$	CTRL Signals, Encode CCIR-656 Mode, Output Hold	20	N/A	ns

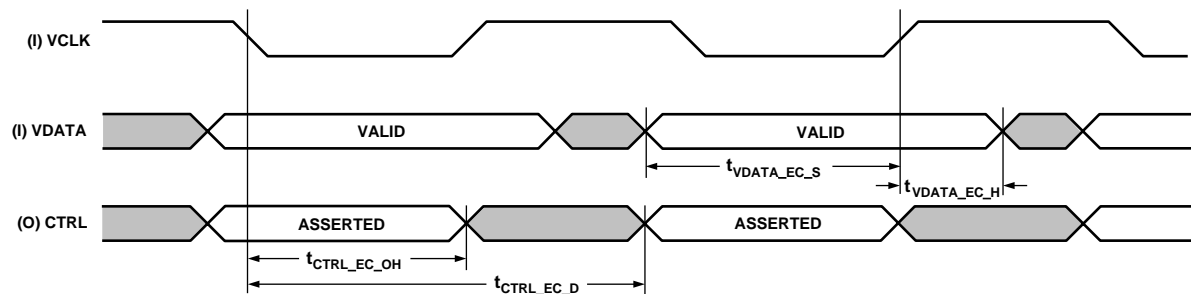

Figure 25. CCIR-656 Video—Encode Pixel (YCrCb) Transfer Timing

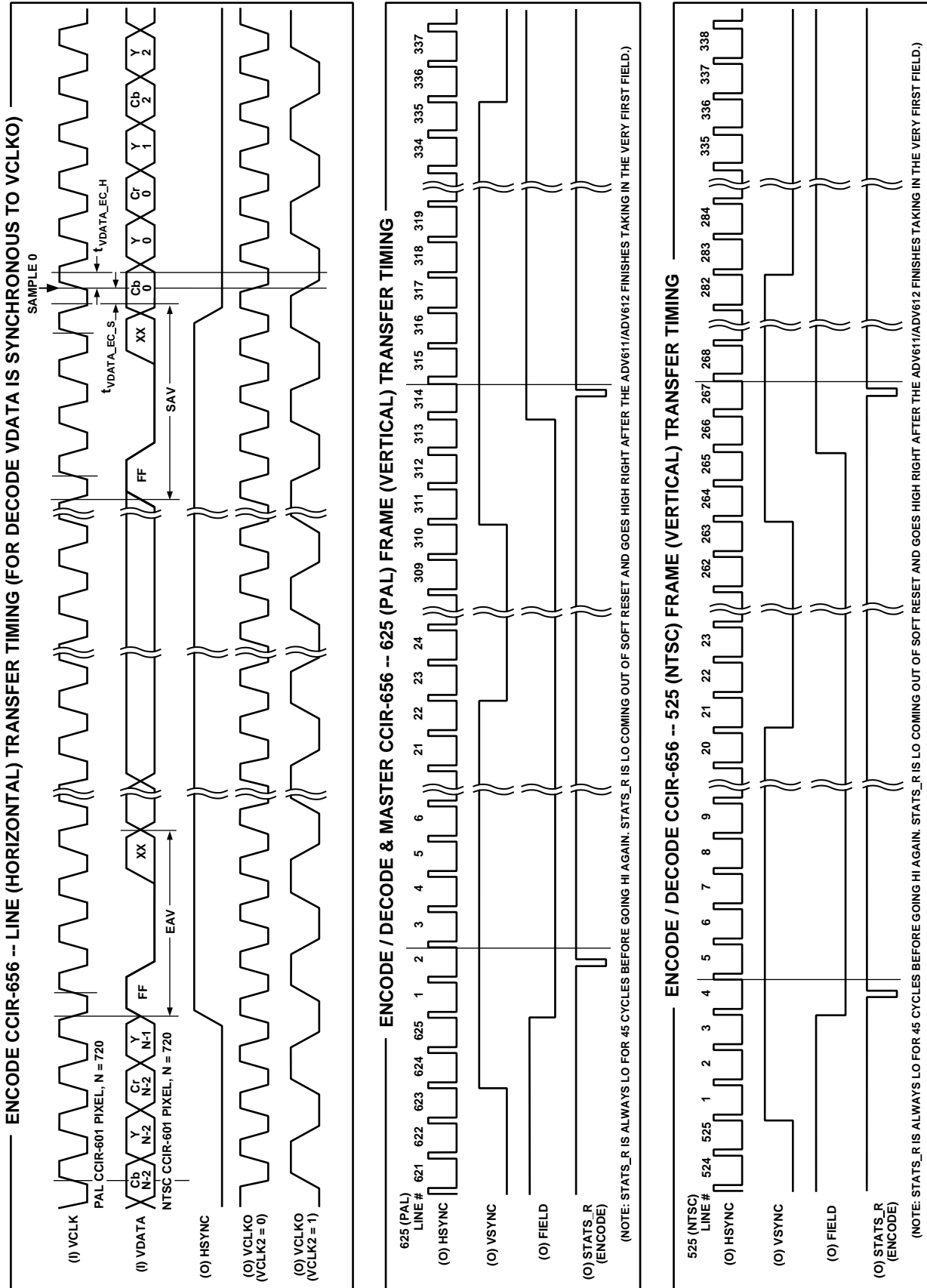

Figure 26. CCIR-656 Video—Line (Horizontal) and Frame (Vertical) Transfer Timing

Note that for CCIR-656 Video—Decode and Master Line (Horizontal) timing, VDATA is synchronous with VCLKO.

Multiplexed Philips Video Timing

The diagrams in this section show transfer timing for pixel (YCrCb) data in Multiplexed Philips video mode. For line (horizontal) and frame (vertical) data transfer timing, see Figure 29. All output values assume a maximum pin loading of 50 pF. Note that in timing diagrams for Multiplexed Philips video, the label CTRL indicates the VSYNC, HSYNC and FIELD pins.

Table XXII. Multiplexed Philips Video—Decode and Master Pixel (YCrCb) Timing Parameters

Parameter	Description	Min	Max	Unit
$t_{VDATA_DMM_D}$	VDATA Bus, Decode Master Multiplexed Philips, Delay	N/A	14	ns
$t_{VDATA_DMM_OH}$	VDATA Bus, Decode Master Multiplexed Philips, Output Hold	4	N/A	ns
$t_{CTRL_DMM_D}$	CTRL Signals, Decode Master Multiplexed Philips, Delay	N/A	11	ns
$t_{CTRL_DMM_OH}$	CTRL Signals, Decode Master Multiplexed Philips, Output Hold	5	N/A	ns

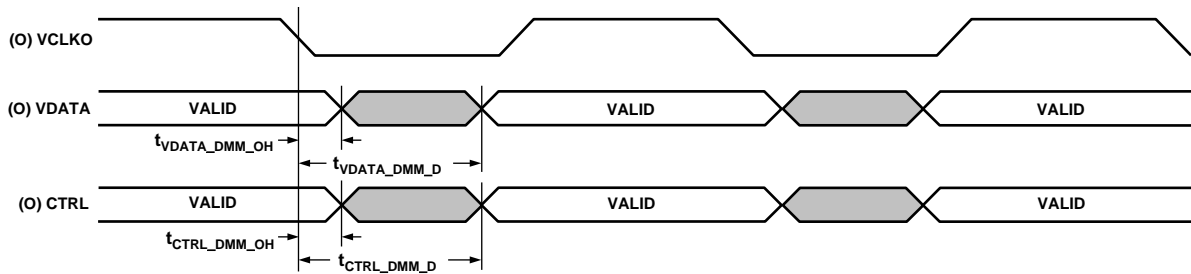

Figure 27. Multiplexed Philips Video—Decode and Master Pixel (YCrCb) Transfer Timing

Table XXIII. Multiplexed Philips Video—Decode and Slave Pixel (YCrCb) Timing Parameters

Parameter	Description	Min	Max	Unit
$t_{VDATA_DSM_D}$	VDATA Bus, Decode Slave Multiplexed Philips, Delay	N/A	14	ns
$t_{VDATA_DSM_OH}$	VDATA Bus, Decode Slave Multiplexed Philips, Output Hold	4	N/A	ns
$t_{CTRL_DSM_S}$	CTRL Signals, Decode Slave Multiplexed Philips, Setup	16	N/A	ns
$t_{CTRL_DSM_H}$	CTRL Signals, Decode Slave Multiplexed Philips, Hold	42	N/A	ns

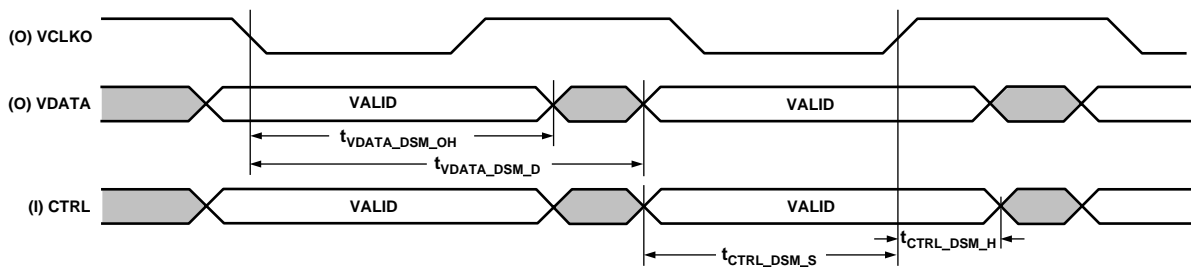

Figure 28. Multiplexed Philips Video—Decode and Slave Pixel (YCrCb) Transfer Timing

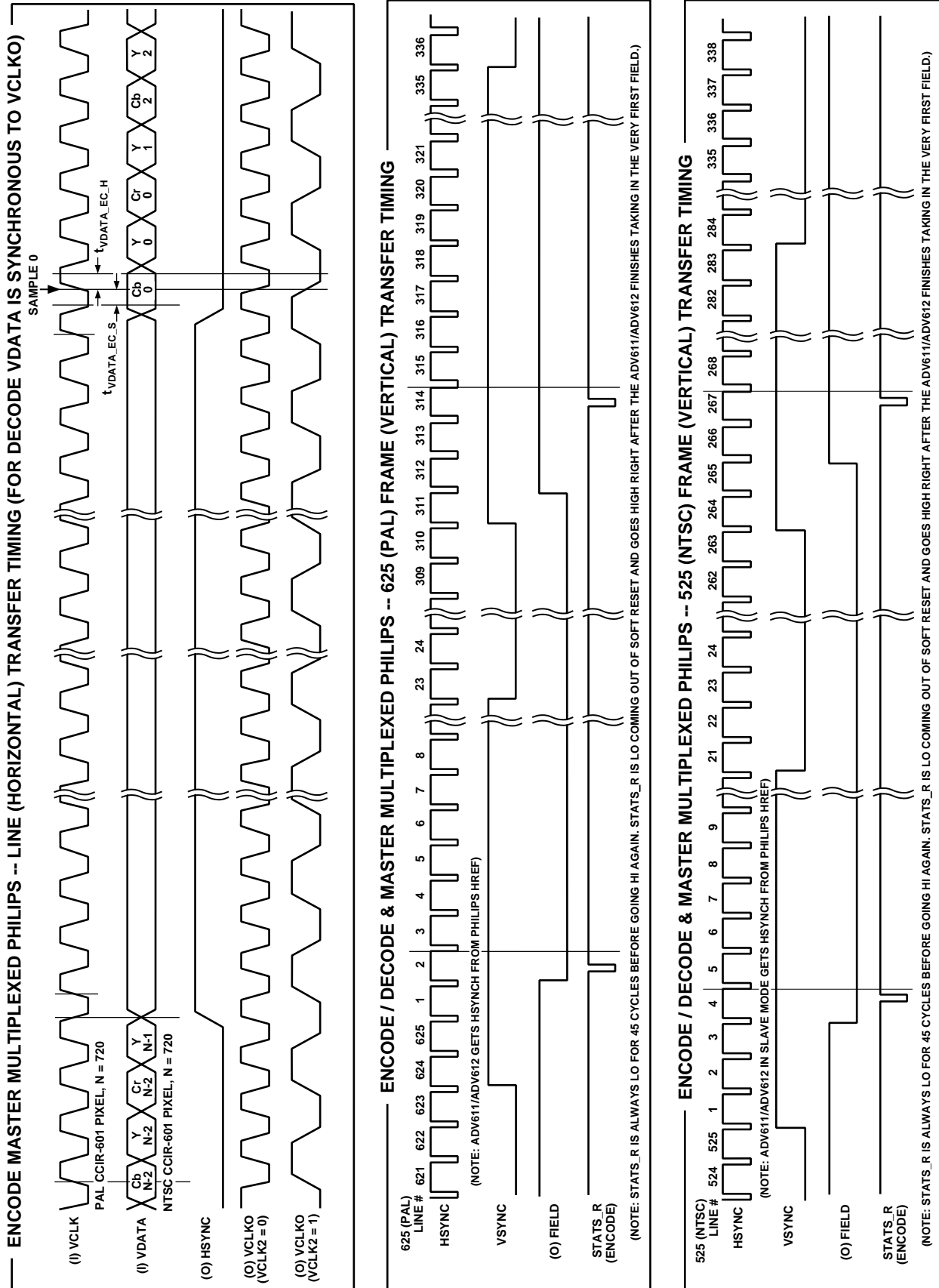

Figure 29. Multiplexed Philips Video-Line (Horizontal) and Frame (Vertical) Transfer Timing

Table XXIV. Multiplexed Philips Video—Encode and Master Pixel (YCrCb) Timing Parameters

Parameter	Description	Min	Max	Unit
$t_{VDATA_EMM_S}$	VDATA Bus, Encode Master Multiplexed Philips, Setup	2	N/A	ns
$t_{VDATA_EMM_H}$	VDATA Bus, Encode Master Multiplexed Philips, Hold	5	N/A	ns
$t_{CTRL_EMM_D}$	CTRL Signals, Encode Master Multiplexed Philips, Delay	N/A	33	ns
$t_{CTRL_EMM_OH}$	CTRL Signals, Encode Master Multiplexed Philips, Output Hold	20	N/A	ns

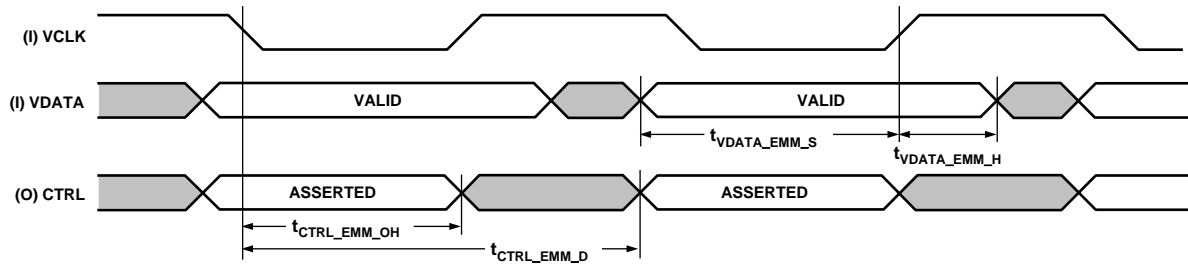

Figure 30. Multiplexed Philips Video—Encode and Master Pixel (YCrCb) Transfer Timing

Table XXV. Multiplexed Philips Video—Encode and Slave Pixel (YCrCb) Timing Parameters

Parameter	Description	Min	Max	Unit
$t_{VDATA_ESM_S}$	VDATA Bus, Encode Slave Multiplexed Philips Mode, Setup	2	N/A	ns
$t_{VDATA_ESM_H}$	VDATA Bus, Encode Slave Multiplexed Philips Mode, Hold	5	N/A	ns
$t_{CTRL_ESM_S}$	CTRL Signals, Encode Slave Multiplexed Philips Mode, Setup	5	N/A	ns
$t_{CTRL_ESM_H}$	CTRL Signals, Encode Slave Multiplexed Philips Mode, Hold	5	N/A	ns

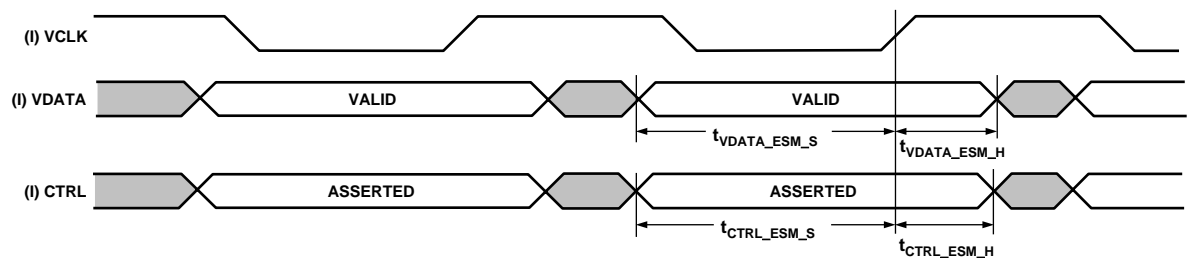

Figure 31. Multiplexed Philips Video—Encode and Slave Pixel (YCrCb) Transfer Timing

ADV611/ADV612

Host Interface (Indirect Address, Indirect Register Data and Interrupt Mask/Status) Register Timing

The diagrams in this section show transfer timing for host read and write accesses to all of the ADV611/ADV612's direct registers, except the Compressed Data register. Accesses to the Indirect Address, Indirect Register Data, and Interrupt Mask/Status registers are *slower* than access timing for the Compressed Data register. For information on access timing for the Compressed Data direct register, see the Host Interface (Compressed Data) Register Timing section. Note that for accesses to the Indirect Address, Indirect Register Data and Interrupt Mask/Status registers, your system *MUST* observe $\overline{\text{ACK}}$ and $\overline{\text{RD}}$ or $\overline{\text{WR}}$ assertion timing.

Table XXVI. Host (Indirect Address, Indirect Data, and Interrupt Mask/Status) Read Timing Parameters

Parameter	Description	Min	Max	Unit
$t_{\text{RD}_D_RDC}$	$\overline{\text{RD}}$ Signal, Direct Register, Read Cycle Time (at 27 MHz VCLK)	N/A ¹	N/A	ns
$t_{\text{RD}_D_PWA}$	$\overline{\text{RD}}$ Signal, Direct Register, Pulswidth Asserted (at 27 MHz VCLK)	N/A ¹	N/A	ns
$t_{\text{RD}_D_PWD}$	$\overline{\text{RD}}$ Signal, Direct Register, Pulswidth Deasserted (at 27 MHz VCLK)	5	N/A	ns
$t_{\text{ADR}_D_RDS}$	ADR Bus, Direct Register, Read Setup	2	N/A	ns
$t_{\text{ADR}_D_RDH}$	ADR Bus, Direct Register, Read Hold	2	N/A	ns
$t_{\text{DATA}_D_RDD}$	DATA Bus, Direct Register, Read Delay	N/A	171.6 ^{2,3}	ns
$t_{\text{DATA}_D_RDOH}$	DATA Bus, Direct Register, Read Output Hold (at 27 MHz VCLK)	26	N/A	ns
$t_{\text{RD}_D_WRT}$	$\overline{\text{WR}}$ Signal, Direct Register, Read-to-Write Turnaround (at 27 MHz VCLK)	48.7 ⁴	N/A	ns
$t_{\text{ACK}_D_RDD}$	$\overline{\text{ACK}}$ Signal, Direct Register, Read Delayed (at 27 MHz VCLK)	8.6	287.1 ^{5,6}	ns
$t_{\text{ACK}_D_RDOH}$	$\overline{\text{ACK}}$ Signal, Direct Register, Read Output Hold (at 27 MHz VCLK)	11	N/A	ns

NOTES

¹ $\overline{\text{RD}}$ input must be asserted (low) until ACK is asserted (low).

²Maximum $t_{\text{DATA}_D_RDD}$ varies with VCLK according to the formula: $t_{\text{DATA}_D_RDD}(\text{MAX}) = 4 (\text{VCLK Period}) + 16$.

³During STATS_R deasserted (low) conditions, $t_{\text{DATA}_D_RDD}$ may be as long as 52 VCLK periods.

⁴Minimum $t_{\text{RD}_D_WRT}$ varies with VCLK according to the formula: $t_{\text{RD}_D_WRT}(\text{MIN}) = 1.5 (\text{VCLK Period}) - 4.1$.

⁵Maximum $t_{\text{ACK}_D_RDD}$ varies with VCLK according to formula: $t_{\text{ACK}_D_RDD}(\text{MAX}) = 7 (\text{VCLK Period}) + 14.8$.

⁶During STATS_R deasserted (low) conditions, $t_{\text{ACK}_D_RDD}$ may be as long as 52 VCLK periods.

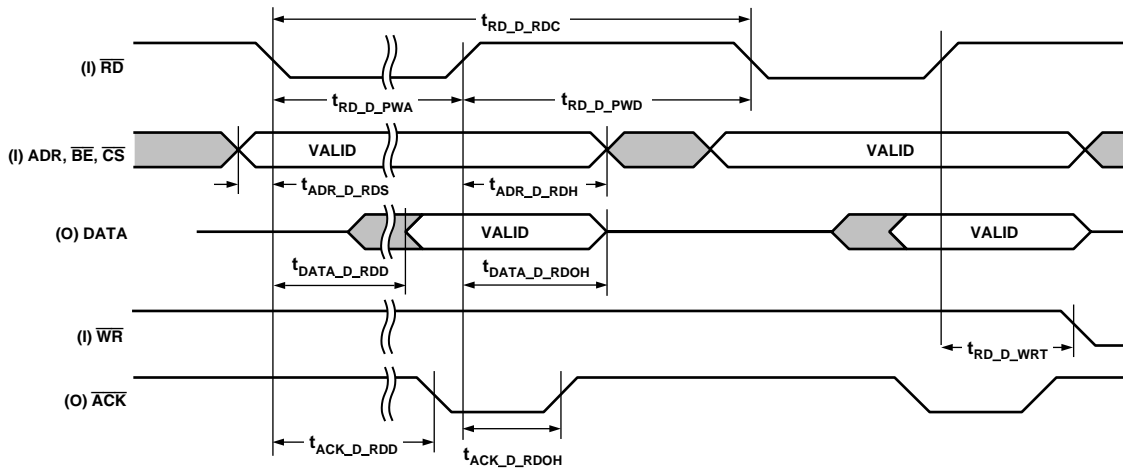

Figure 32. Host (Indirect Address, Indirect Register Data, and Interrupt Mask/Status) Read Transfer Timing

Table XXVII. Host (Indirect Address, Indirect Data and Interrupt Mask/Status) Write Timing Parameters

Parameter	Description	Min	Max	Unit
$t_{WR_D_WRC}$	\overline{WR} Signal, Direct Register, Write Cycle Time (at 27 MHz VCLK)	N/A ¹	N/A	ns
$t_{WR_D_PWA}$	\overline{WR} Signal, Direct Register, Pulsewidth Asserted (at 27 MHz VCLK)	N/A ¹	N/A	ns
$t_{WR_D_PWD}$	\overline{WR} Signal, Direct Register, Pulsewidth Deasserted (at 27 MHz VCLK)	5	N/A	ns
$t_{ADR_D_WRS}$	ADR Bus, Direct Register, Write Setup	2	N/A	ns
$t_{ADR_D_WRH}$	ADR Bus, Direct Register, Write Hold	2	N/A	ns
$t_{DATA_D_WRS}$	DATA Bus, Direct Register, Write Setup	-10	N/A	ns
$t_{DATA_D_WRH}$	DATA Bus, Direct Register, Write Hold	0	N/A	ns
$t_{WR_D_RDT}$	\overline{WR} Signal, Direct Register, Read Turnaround (After a Write) (at 27 MHz VCLK)	35.6 ²	N/A	ns
$t_{ACK_D_WRD}$	\overline{ACK} Signal, Direct Register, Write Delay (at 27 MHz VCLK)	8.6	182.1 ^{3,4}	ns
$t_{ACK_D_WROH}$	\overline{ACK} Signal, Direct Register, Write Output Hold	11	N/A	ns

NOTES

¹ \overline{WR} input must be asserted (low) until ACK is asserted (low).

²Minimum $t_{WR_D_RDT}$ varies with VCLK according to the formula: $t_{WR_D_RDT (MIN)} = 0.8 (\text{VCLK Period}) + 7.4$.

³Maximum $t_{WR_D_WRD}$ varies with VCLK according to the formula: $t_{ACK_D_WRD (MAX)} = 4.3 (\text{VCLK Period}) + 14.8$.

⁴During $\overline{STATS_R}$ deasserted (low) conditions, $t_{ACK_D_WRD}$ may be as long as 52 VCLK periods.

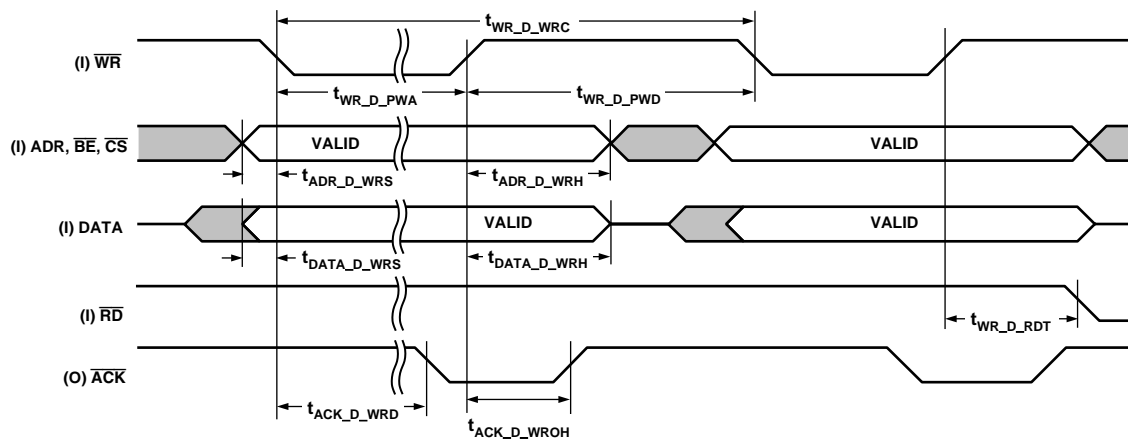

Figure 33. Host (Indirect Address, Indirect Register Data, and Interrupt Mask/Status) Write Transfer Timing

ADV611/ADV612

Host Interface (Compressed Data) Register Timing

The diagrams in this section show transfer timing for host read and write transfers to the ADV611/ADV612's Compressed Data register. Accesses to the Compressed Data register are faster than access timing for the Indirect Address, Indirect Register Data, and Interrupt Mask/Status registers. For information on access timing for the other registers, see the Host Interface (Indirect Address, Indirect Register Data, and Interrupt Mask/Status) Register Timing section. Also note that as long as your system observes the \overline{RD} or \overline{WR} signal assertion timing, your system does *NOT* have to wait for the \overline{ACK} signal between new compressed data addresses.

Table XXVIII. Host (Compressed Data) Read Timing Parameters

Parameter	Description	Min	Max	Unit
$t_{RD_CD_RDC}$	\overline{RD} Signal, Compressed Data Direct Register, Read Cycle Time	28	N/A	ns
$t_{RD_CD_PWA}$	\overline{RD} Signal, Compressed Data Direct Register, Pulsewidth Asserted	10	N/A	ns
$t_{RD_CD_PWD}$	\overline{RD} Signal, Compressed Data Direct Register, Pulsewidth Deasserted	10	N/A	ns
$t_{ADR_CD_RDS}$	ADR Bus, Compressed Data Direct Register, Read Setup	2	N/A	ns
$t_{ADR_CD_RDH}$	ADR Bus, Compressed Data Direct Register, Read Hold (at 27 MHz VCLK)	2	N/A	ns
$t_{DATA_CD_RDD}$	DATA Bus, Compressed Data Direct Register, Read Delay	N/A	10	ns
$t_{DATA_CD_RDOH}$	DATA Bus, Compressed Data Direct Register, Read Output Hold	18	N/A	ns
$t_{ACK_CD_RDD}$	\overline{ACK} Signal, Compressed Data Direct Register, Read Delay	N/A	18	ns
$t_{ACK_CD_RDOH}$	\overline{ACK} Signal, Compressed Data Direct Register, Read Output Hold	9	N/A	ns

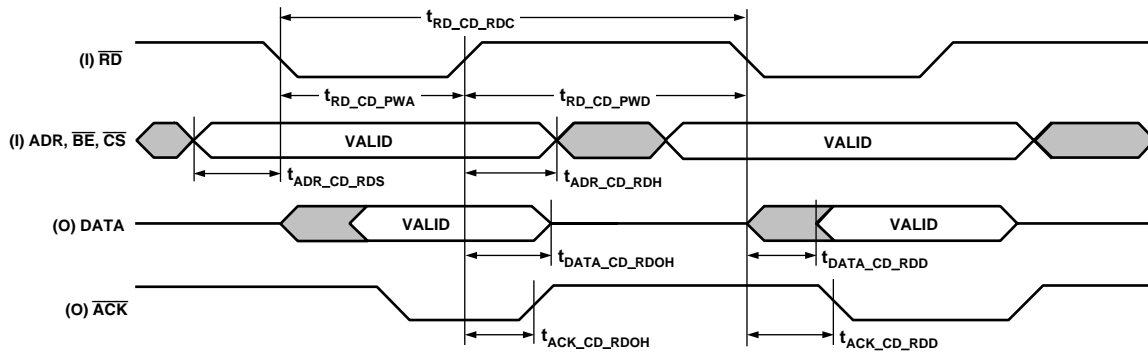

Figure 34. Host (Compressed Data) Read Transfer Timing

Table XXIX. Host (Compressed Data) Write Timing Parameters

Parameter	Description	Min	Max	Unit
$t_{WR_CD_WRC}$	\overline{WR} Signal, Compressed Data Direct Register, Write Cycle Time	28	N/A	ns
$t_{WR_CD_PWA}$	\overline{WR} Signal, Compressed Data Direct Register, Pulsewidth Asserted	10	N/A	ns
$t_{WR_CD_PWD}$	\overline{WR} Signal, Compressed Data Direct Register, Pulsewidth Deasserted	10	N/A	ns
$t_{ADR_CD_WRS}$	ADR Bus, Compressed Data Direct Register, Write Setup	2	N/A	ns
$t_{ADR_CD_WRH}$	ADR Bus, Compressed Data Direct Register, Write Hold	2	N/A	ns
$t_{DATA_CD_WRS}$	DATA Bus, Compressed Data Direct Register, Write Setup	2	N/A	ns
$t_{DATA_CD_WRH}$	DATA Bus, Compressed Data Direct Register, Write Hold	2	N/A	ns
$t_{ACK_CD_WRD}$	\overline{ACK} Signal, Compressed Data Direct Register, Write Delay	N/A	19	ns
$t_{ACK_CD_WROH}$	\overline{ACK} Signal, Compressed Data Direct Register, Write Output Hold	9	N/A	ns

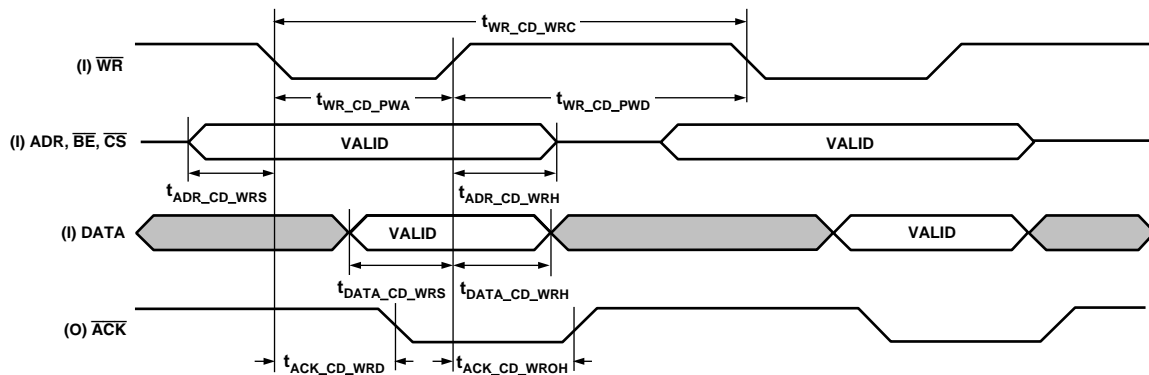

Figure 35. Host (Compressed Data) Write Transfer Timing

ADV611/ADV612

ADV611/ADV612 LQFP PINOUTS

Pin	Pin Name	Pin Type	Pin	Pin Name	Pin Type	Pin	Pin Name	Pin Type
1	DATA4	I/O	41	$\overline{\text{CAS}}$	O	81	VDATA4	I/O
2	DATA3	I/O	42	$\overline{\text{WE}}$	O	82	GND	GROUND
3	DATA2	I/O	43	VDD	POWER	83	VDD	POWER
4	DATA1	I/O	44	VDD	POWER	84	VDATA3	I/O
5	DATA0	I/O	45	DDAT15	I/O	85	VDATA2	I/O
6	VDD	POWER	46	DDAT14	I/O	86	VDATA1	I/O
7	GND	GROUND	47	DDAT13	I/O	87	VDATA0	I/O
8	$\overline{\text{RD}}$	I	48	DDAT12	I/O	88	NC*	NC
9	$\overline{\text{WR}}$	I	49	DDAT11	I/O	89	NC*	NC
10	$\overline{\text{CS}}$	I	50	DDAT10	I/O	90	GND	GROUND
11	ADR1	I	51	DDAT9	I/O	91	DATA31	I/O
12	ADR0	I	52	DDAT8	I/O	92	DATA30	I/O
13	GND	GROUND	53	DDAT7	I/O	93	DATA29	I/O
14	$\overline{\text{BE2}}\text{-}\overline{\text{BE3}}$	I	54	DDAT6	I/O	94	DATA28	I/O
15	$\overline{\text{BE0}}\text{-}\overline{\text{BE1}}$	I	55	DDAT5	I/O	95	DATA27	I/O
16	GND	GROUND	56	DDAT4	I/O	96	DATA26	I/O
17	$\overline{\text{RESET}}$	I	57	DDAT3	I/O	97	DATA25	I/O
18	VDD	POWER	58	DDAT2	I/O	98	DATA24	I/O
19	$\overline{\text{ACK}}$	O	59	DDAT1	I/O	99	DATA23	I/O
20	VDD	POWER	60	DDAT0	I/O	100	DATA22	I/O
21	GND	GROUND	61	GND	GROUND	101	DATA21	I/O
22	$\overline{\text{HIRQ}}$	O	62	VDD	POWER	102	DATA20	I/O
23	LCODE	O	63	GND	GROUND	103	VDD	POWER
24	FIFO_SRQ	O	64	VDD	POWER	104	DATA19	I/O
25	STATS_R	O	65	$\overline{\text{STALL}}$	I	105	DATA18	I/O
26	VDD	POWER	66	GND	GROUND	106	DATA17	I/O
27	GND	GROUND	67	ENC	O	107	DATA16	I/O
28	GND	GROUND	68	VCLKO	O	108	GND	GROUND
29	VDD	POWER	69	VDD	POWER	109	GND	GROUND
30	DADR8	O	70	XTAL	I	110	DATA15	I/O
31	DADR7	O	71	VCLK	I	111	DATA14	I/O
32	DADR6	O	72	GND	GROUND	112	DATA13	I/O
33	DADR5	O	73	FIELD	I OR O	113	DATA12	I/O
34	DADR4	O	74	HSYNC	I OR O	114	DATA11	I/O
35	DADR3	O	75	VSYNC	I OR O	115	DATA10	I/O
36	DADR2	O	76	GND	GROUND	116	DATA9	I/O
37	DADR1	O	77	VDD	POWER	117	DATA8	I/O
38	DADR0	O	78	VDATA7	I/O	118	DATA7	I/O
39	GND	GROUND	79	VDATA6	I/O	119	DATA6	I/O
40	$\overline{\text{RAS}}$	O	80	VDATA5	I/O	120	DATA5	I/O

*Apply a 10 k Ω pull-down resistor to this pin.

ADV611/ADV612 PIN CONFIGURATION

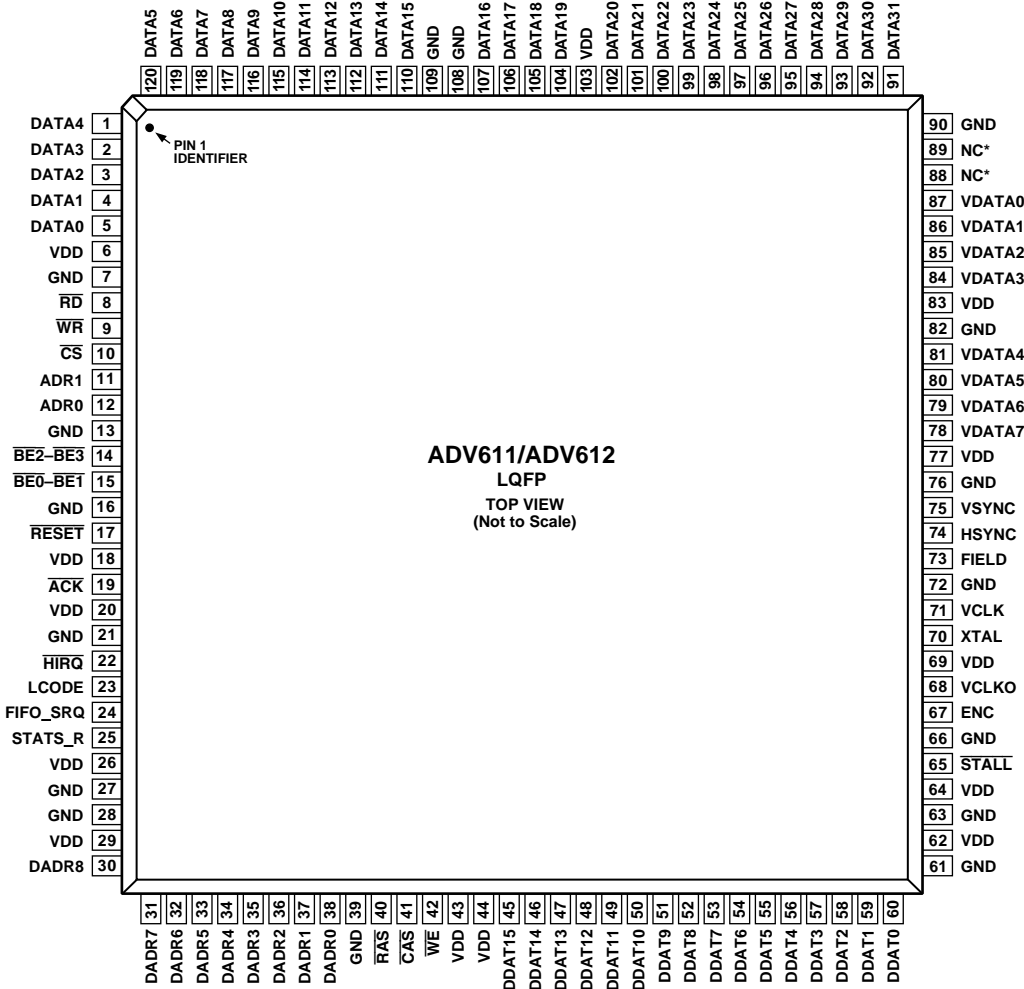

*APPLY A 10kΩ PULL DOWN RESISTOR TO THIS PIN

ADV611/ADV612

OUTLINE DIMENSIONS

Dimensions shown in inches and (mm).

120-Lead LQFP (ST-120)

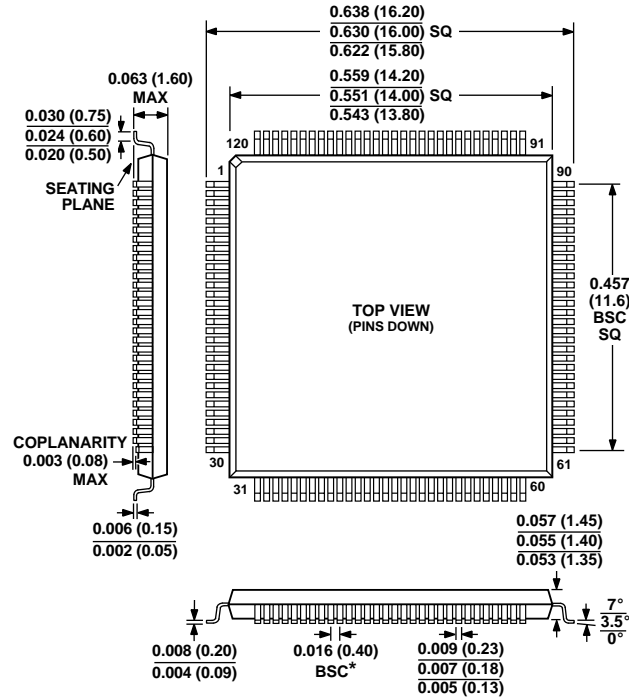

* THE ACTUAL POSITION OF EACH LEAD IS WITHIN 0.07 mm LATERAL TO THE PINS TRUE POSITION. CENTER FIGURES ARE TYPICAL UNLESS OTHERWISE NOTED

ORDERING GUIDE

Part Number	Ambient Temperature Range ¹	Package Description	Package Options ²
ADV611JST	0°C to +70°C	120-Lead LQFP	ST-120
ADV612BST ³	-25°C to +85°C	120-Lead LQFP	ST-120

NOTES

¹J = Commercial temperature range (0°C to +70°C).

²ST = Plastic Thin Quad Flatpack.

³B = Standard Industrial Temperature Range (-25°C to +85°C).

X-ON Electronics

Largest Supplier of Electrical and Electronic Components

Click to view similar products for [Interface - CODECs](#) category:

Click to view products by [Analog Devices](#) manufacturer:

Other Similar products are found below :

[CS4205-KQZ](#) [ZL38015QCG1](#) [MAX98090AEWJ+T](#) [WM9713CLGEFLV](#) [LE58QL061BVC](#) [ADAU1777BCBZRL](#) [WM8944BECS/R](#)
[TDA7293V-E](#) [WM8998ECS/R](#) [WM8778SEDS/V](#) [CS42L73-CRZR](#) [WM8750CJLGEFL](#) [STA529Q](#) [SSM2603CPZ-REEL](#)
[TLV320AIC14IDBT](#) [TLV320AIC23BIPWRQ1](#) [TLV320AIC23IPW](#) [TVP5151PBSR](#) [MAX98090BETL+](#) [MAX98089ETN+](#)
[MAX98089ETNT](#) [TLV320AIC34IZASR](#) [TLV320AIC3262IYZFR](#) [SA612AD/01.112](#) [MAX98090AETL+](#) [MAX9880AETM](#)
[WM8962ECSN/R](#) [TLV320DAC3203IRGER](#) [WM8904CGEFL/RV](#) [6PAIC3106IRGZRQ1](#) [CS42436-DMZ](#) [TSCS25A3X1NDGXZAX](#)
[BU94502CMUV-E2](#) [TDA8932BT/N2.112](#) [TDA8954J/N1.112](#) [ICS501MLFT](#) [ICS512MLF](#) [92HD73C1T5PRGIC1X](#)
[92HD73C1X5PRGXC1X](#) [SSM2167-1RMZ](#) [AD1836AASZ](#) [AD1836ACSZ](#) [AD1928YSTZ](#) [AD1937WBSTZ](#) [AD1939WBSTZ](#)
[AD73311ARSZ](#) [AD73311ARZ](#) [AD73311LARUZ](#) [AD73322LARUZ](#) [AD74111YRUZ](#)