

# **ADSP-21371 EZ-KIT Lite® Evaluation System Manual**

Revision 1.1, August 2012

Part Number  
82-000230-01

Analog Devices, Inc.  
One Technology Way  
Norwood, Mass. 02062-9106



## Copyright Information

© 2012 Analog Devices, Inc., ALL RIGHTS RESERVED. This document may not be reproduced in any form without prior, express written consent from Analog Devices, Inc.

Printed in the USA.

## Disclaimer

Analog Devices, Inc. reserves the right to change this product without prior notice. Information furnished by Analog Devices is believed to be accurate and reliable. However, no responsibility is assumed by Analog Devices for its use; nor for any infringement of patents or other rights of third parties which may result from its use. No license is granted by implication or otherwise under the patent rights of Analog Devices, Inc.

## Trademark and Service Mark Notice

The Analog Devices logo, CrossCore, EngineerZone, EZ-KIT Lite, SHARC, and VisualDSP++ are registered trademarks of Analog Devices, Inc.

All other brand and product names are trademarks or service marks of their respective owners.

## Regulatory Compliance

The ADSP-21371 EZ-KIT Lite is designed to be used solely in a laboratory environment. The board is not intended for use as a consumer end product or as a portion of a consumer end product. The board is an open system design which does not include a shielded enclosure and therefore may cause interference to other electrical devices in close proximity. This board should not be used in or near any medical equipment or RF devices.

The ADSP-21371 EZ-KIT Lite has been certified to comply with the essential requirements of the European EMC directive 2004/108/EC and therefore carries the “CE” mark.

The ADSP-21371 EZ-KIT Lite has been appended to Analog Devices, Inc. EMC Technical File (EMC TF) referenced **DSPTOOLS1** and was declared CE compliant by an appointed Notified Body (No.0673) as listed below.

Notified Body Statement of Compliance: Z600ANA2.040 dated June 22 2010.



Issued by: Technology International (Europe) Limited  
56 Shrivenham Hundred Business Park  
Shrivenham, Swindon, SN6 8TY, UK

The EZ-KIT Lite evaluation system contains ESD (electrostatic discharge) sensitive devices. Electrostatic charges readily accumulate on the human body and equipment and can discharge without detection. Permanent damage may occur on devices subjected to high-energy discharges. Proper ESD precautions are recommended to avoid performance degradation or loss of functionality. Store unused EZ-KIT Lite boards in the protective shipping package.





# CONTENTS

## PREFACE

Product Overview .....	x
Purpose of This Manual .....	xii
Intended Audience .....	xiii
Manual Contents .....	xiii
What's New in This Manual .....	xiv
Technical Support .....	xiv
Supported Processors .....	xv
Product Information .....	xvi
Analog Devices Web Site .....	xvi
EngineerZone .....	xvii
Related Documents .....	xvii
Notation Conventions .....	xviii

## USING THE ADSP-21371 EZ-KIT LITE

Package Contents .....	1-2
Default Configuration .....	1-3
CCES Install and Session Startup .....	1-4
Session Startup .....	1-6

## Contents

VisualDSP++ Install and Session Startup .....	1-8
Session Startup .....	1-9
CCES Evaluation License .....	1-10
VisualDSP++ Evaluation License .....	1-11
External Memory .....	1-12
ELVIS Interface .....	1-13
Analog Audio .....	1-14
LEDs and Push Buttons .....	1-15
Example Programs .....	1-17
Board Design Database .....	1-17

## ADSP-21371 EZ-KIT LITE HARDWARE REFERENCE

System Architecture .....	2-2
External Port .....	2-3
DAI Interface .....	2-3
DPI Interface .....	2-5
FLAG Pins .....	2-6
External PLL .....	2-6
Expansion Interface .....	2-7
JTAG Emulation Port .....	2-7
Switches .....	2-8
Boot Mode and Clock Ratio Select Switch (SW2) .....	2-9
Codec Setup Switch (SW3) .....	2-10
Electret Microphone Select Switch (SW4) .....	2-11
UART Enable Switch (SW5) .....	2-11

## Contents

Loopback Test Switches (SW6 and SW14) .....	2-11
Push Button Enable Switch (SW7) .....	2-12
ELVIS Oscilloscope Configuration Switch (SW1) .....	2-12
ELVIS Function Generator Configuration Switch (SW13) .....	2-13
AD1835A and Flash Disconnect Switch (SW15) .....	2-14
LEDs and Push Buttons .....	2-14
General Purpose LEDs (LED1–8) .....	2-15
Power LED (LED9) .....	2-15
Reset LED (LED10) .....	2-15
USB Monitor LED (ZLED3) .....	2-15
Push Buttons (SW8–11) .....	2-16
Board Reset Push Button (SW12) .....	2-16
Jumpers .....	2-17
VCO Select Jumper (JP1) .....	2-18
ELVIS Select Jumper (JP2) .....	2-18
ELVIS Voltage Selection Jumper (JP3) .....	2-19
ELVIS Programmable Flag Jumper (JP4) .....	2-19
Connectors .....	2-20
Expansion Interface Connectors (J1–3) .....	2-21
Audio In RCA Connector (J10) .....	2-21
Audio Out RCA Connector (J5) .....	2-22
Headphone Out Jack (J9) .....	2-22
Power Jack (J4) .....	2-22
S/PDIF Coax Connectors (J7 and J8) .....	2-23

## Contents

DPI Header (P3) .....	2-23
DAI Header (P4) .....	2-24
JTAG Header (ZP4) .....	2-24

**ADSP-21371 EZ-KIT LITE BILL OF MATERIALS**

**ADSP-21371 EZ-KIT LITE SCHEMATIC**

**INDEX**



# PREFACE

Thank you for purchasing the ADSP-21371 EZ-KIT Lite<sup>®</sup>, Analog Devices, Inc. evaluation system for SHARC<sup>®</sup> processors.

SHARC processors are based on a 32-bit super Harvard architecture that includes a unique memory architecture comprised of two large on-chip, dual-ported SRAM blocks coupled with a sophisticated I/O processor, which gives a SHARC processor the bandwidth for sustained high-speed computations. SHARC processors represents today's de facto standard for floating-point processing, targeted toward premium audio applications.

The evaluation system is designed to be used in conjunction with the CrossCore<sup>®</sup> Embedded Studio (CCES) and VisualDSP++<sup>®</sup> development environments to test capabilities of the ADSP-21371 SHARC processors. The development environment aids advanced application code development and debug, such as:

- Create, compile, assemble, and link application programs written in C++, C, and ADSP-21371 assembly
- Load, run, step, halt, and set breakpoints in application program
- Read and write data and program memory
- Read and write core and peripheral registers
- Plot memory

Access to the ADSP-21371 processor from a personal computer (PC) is achieved through a USB port or an external JTAG emulator. The USB interface provides unrestricted access to the ADSP-21371 processor and

## Product Overview

evaluation board peripherals. Analog Devices JTAG emulators offer faster communication between the host PC and target hardware. Analog Devices carries a wide range of in-circuit emulation products. To learn more about Analog Devices emulators and processor development tools, go to <http://www.analog.com/dsp/tools>.

The ADSP-21371 EZ-KIT Lite provides example programs to demonstrate capabilities of the evaluation board.

## Product Overview

The board features:

- Analog Devices ADSP-21371 processor
  - 208-pin MQFP package
  - 266 MHz core clock speed
- Synchronous dynamic random access memory (SDRAM)
  - 1M x 32-bit x 4 banks
- Flash memory
  - 1M x 8-bit
- Serial peripheral interface (SPI) flash memory
  - 2M bit

- Analog audio interface
  - Analog Devices AD1835A audio codec
  - 4 x 2 RCA phono jack for four channels of stereo output
  - 2 x 1 RCA phono jack for one channel of stereo input
  - 3.5 mm headphone jack for one channel stereo output
- Universal asynchronous receiver/transmitter (UART)
  - ADM3202 RS-232 driver/receiver
  - DB9 female connector
- National Instruments Educational Laboratory Virtual Instrumentation Suite (ELVIS) Interface
  - LabVIEW™-based virtual instruments
  - Multifunction data acquisition device
  - Bench-top workstation and prototype board
- LEDs
  - Eleven LEDs: one power (green), one board reset (red), one USB monitor (amber), and eight general-purpose (amber)
- Push buttons
  - Five push buttons: one reset, two connected to DAI, and two connected to the FLAG pins of the processor
- Expansion interface (type A)
  - Parallel port, FLAG pins, DPI, DAI

## Purpose of This Manual

- Other features
  - JTAG ICE 14-pin header
  - Test points for processor current measurement
  - DPI header
  - DAI header

The EZ-KIT Lite board has a total of 1 MB of parallel flash memory and 2M bit of SPI flash memory. Flash memories can store user-specific boot code and allow the board to run as a standalone unit. For more information, see [“External Memory” on page 1-12](#) and [“Boot Mode and Clock Ratio Select Switch \(SW2\)” on page 2-9](#). The board has 16 MB of SDRAM, which can be used at runtime or from which code can be executed.

The DAI port of the processor is connected to the AD1835A audio codec and an external phase lock loop (PLL). The DAI interface facilitates development of digital and analog audio signal-processing applications. See [“Analog Audio” on page 1-14](#) for more information.

The DPI port of the processor is connected to the UART and SPI interfaces. The UART interface can connect to a standard RS-232, while the SPI connects to the 2M bit of serial flash memory.

Additionally, the EZ-KIT Lite board provides access to all of the processor’s peripheral ports. Access is provided in the form of a three-connector expansion interface. See [“Expansion Interface” on page 2-7](#) for details.

## Purpose of This Manual

The *ADSP-21371 EZ-KIT Lite Evaluation System Manual* provides instructions for installing the product hardware (board). The text describes operation and configuration of the board components and

provides guidelines for running your own code on the ADSP-21371 EZ-KIT Lite. Finally, a schematic and a bill of materials are provided for reference.

## Intended Audience

The primary audience for this manual is a programmer who is familiar with Analog Devices processors. This manual assumes that the audience has a working knowledge of the appropriate processor architecture and instruction set.

Programmers who are unfamiliar with Analog Devices processors can use this manual but should supplement it with other texts that describe your target architecture. For the locations of these documents, see [“Related Documents”](#).

Programmers who are unfamiliar with CCES or VisualDSP++ should refer to the online help and the user’s manuals.

## Manual Contents

The manual consists of:

- Chapter 1, [“Using the ADSP-21371 EZ-KIT Lite” on page 1-1](#)  
Describes EZ-KIT Lite functionality from a programmer’s perspective and provides an easy-to-access memory map.
- Chapter 2, [“ADSP-21371 EZ-KIT Lite Hardware Reference” on page 2-1](#)  
Provides information on the EZ-KIT Lite hardware components.

## What's New in This Manual

- Appendix A, “[ADSP-21371 EZ-KIT Lite Bill of Materials](#)” on [page A-1](#)  
Provides a list of components used to manufacture the EZ-KIT Lite board.
- Appendix B, “[ADSP-21371 EZ-KIT Lite Schematic](#)” on [page B-1](#)  
Provides the resources to allow board-level debugging or to use as a reference guide. Appendix B is part of the online help.

## What's New in This Manual

This is revision 1.1 of the *ADSP-21371 EZ-KIT Lite Evaluation System Manual*. The manual has been updated to include CCES information. In addition, modifications and corrections based on errata reports against the previous manual revision have been made.

For the latest version of this manual, please refer to the Analog Devices Web site.

## Technical Support

You can reach Analog Devices processors and DSP technical support in the following ways:

- Post your questions in the processors and DSP support community at EngineerZone®:  
<http://ez.analog.com/community/dsp>
- Submit your questions to technical support directly at:  
<http://www.analog.com/support>

- E-mail your questions about processors, DSPs, and tools development software from **CrossCore Embedded Studio** or **VisualDSP++**:

Choose **Help > Email Support**. This creates an e-mail to [processor.tools.support@analog.com](mailto:processor.tools.support@analog.com) and automatically attaches your **CrossCore Embedded Studio** or **VisualDSP++** version information and `license.dat` file.

- E-mail your questions about processors and processor applications to:  
[processor.support@analog.com](mailto:processor.support@analog.com) or  
[processor.china@analog.com](mailto:processor.china@analog.com) (Greater China support)
- In the **USA only**, call **1-800-ANALOGD** (1-800-262-5643)
- Contact your Analog Devices sales office or authorized distributor. Locate one at:  
[www.analog.com/adi-sales](http://www.analog.com/adi-sales)
- Send questions by mail to:  
Processors and DSP Technical Support  
Analog Devices, Inc.  
Three Technology Way  
P.O. Box 9106  
Norwood, MA 02062-9106  
USA

## Supported Processors

The ADSP-21371 EZ-KIT Lite evaluation system supports Analog Devices ADSP-21371 SHARC processors.

## Product Information

# Product Information

Product information can be obtained from the Analog Devices Web site and the online help system.

## Analog Devices Web Site

The Analog Devices Web site, [www.analog.com](http://www.analog.com), provides information about a broad range of products—analogue integrated circuits, amplifiers, converters, and digital signal processors.

To access a complete technical library for each processor family, go to [http://www.analog.com/processors/technical\\_library](http://www.analog.com/processors/technical_library). The manuals selection opens a list of current manuals related to the product as well as a link to the previous revisions of the manuals. When locating your manual title, note a possible errata check mark next to the title that leads to the current correction report against the manual.

Also note, [myAnalog](#) is a free feature of the Analog Devices Web site that allows customization of a Web page to display only the latest information about products you are interested in. You can choose to receive weekly e-mail notifications containing updates to the Web pages that meet your interests, including documentation errata against all manuals. [myAnalog](#) provides access to books, application notes, data sheets, code examples, and more.

Visit [myAnalog](#) (found on the Analog Devices home page) to sign up. If you are a registered user, just log on. Your user name is your e-mail address.



## EngineerZone

EngineerZone is a technical support forum from Analog Devices. It allows you direct access to ADI technical support engineers. You can search FAQs and technical information to get quick answers to your embedded processing and DSP design questions.

Use EngineerZone to connect with other DSP developers who face similar design challenges. You can also use this open forum to share knowledge and collaborate with the ADI support team and your peers. Visit <http://ez.analog.com> to sign up.

## Related Documents

For additional information about the product, refer to the following publications.



Table 1. Related Processor Publications

Title	Description
<i>ADSP-21371/ADSP-21375 SHARC Processor Data Sheet</i>	General functional description, pinout, and timing of the processor
<i>ADSP-2137x SHARC Processor Hardware Reference</i>	Description of the internal processor architecture, registers, and all peripheral functions
<i>SHARC Processor Programming Reference</i>	Description of all allowed processor assembly instructions

## Notation Conventions

# Notation Conventions

Text conventions used in this manual are identified and described as follows.

Example	Description
Close command (File menu)	Titles in reference sections indicate the location of an item within the development environment's menu system (for example, the <b>Close</b> command appears on the <b>File</b> menu).
{this   that}	Alternative required items in syntax descriptions appear within curly brackets and separated by vertical bars; read the example as <i>this</i> or <i>that</i> . One or the other is required.
[this   that]	Optional items in syntax descriptions appear within brackets and separated by vertical bars; read the example as an optional <i>this</i> or <i>that</i> .
[this,...]	Optional item lists in syntax descriptions appear within brackets delimited by commas and terminated with an ellipsis; read the example as an optional comma-separated list of <i>this</i> .
.SECTION	Commands, directives, keywords, and feature names are in text with letter gothic font.
<i>filename</i>	Non-keyword placeholders appear in text with italic style format.
	<b>Note:</b> For correct operation, ... A Note provides supplementary information on a related topic. In the online version of this book, the word <b>Note</b> appears instead of this symbol.
	<b>Caution:</b> Incorrect device operation may result if ... <b>Caution:</b> Device damage may result if ... A Caution identifies conditions or inappropriate usage of the product that could lead to undesirable results or product damage. In the online version of this book, the word <b>Caution</b> appears instead of this symbol.
	<b>Warning:</b> Injury to device users may result if ... A Warning identifies conditions or inappropriate usage of the product that could lead to conditions that are potentially hazardous for the devices users. In the online version of this book, the word <b>Warning</b> appears instead of this symbol.

# 1 USING THE ADSP-21371 EZ-KIT LITE

This chapter provides specific information to assist you with development of programs for the ADSP-21371 EZ-KIT Lite evaluation system.

The information appears in the following sections.

- [“Package Contents” on page 1-2](#)  
Lists items contained in your EZ-KIT Lite package.
- [“Default Configuration” on page 1-3](#)  
Shows the default configuration of the EZ-KIT Lite board.
- [“CCES Install and Session Startup” on page 1-4](#)  
Instructs how to start a new or open an existing EZ-KIT Lite session using CCES.
- [“VisualDSP++ Install and Session Startup” on page 1-8](#)  
Instructs how to start a new or open an existing EZ-KIT Lite session using VisualDSP++.
- [“CCES Evaluation License” on page 1-10](#)  
Describes the CCES demo license shipped with the EZ-KIT Lite.
- [“VisualDSP++ Evaluation License” on page 1-11](#)  
Describes the VisualDSP++ demo license shipped with the EZ-KIT Lite.
- [“External Memory” on page 1-12](#)  
Defines the memory map of the EZ-KIT Lite; describes how to access external memory.

## Package Contents

- [“ELVIS Interface” on page 1-13](#)  
Describes the on-board National Instruments Educational Laboratory Virtual Instrumentation Suite (NI ELVIS) interface.
- [“Analog Audio” on page 1-14](#)  
Describes how to set up and communicate with the on-board audio codec.
- [“LEDs and Push Buttons” on page 1-15](#)  
Describes the board’s general-purpose I/O pins and buttons.
- [“Example Programs” on page 1-17](#)  
Provides information about example programs included in the evaluation system.
- [“Board Design Database” on page 1-17](#)  
Highlights the available technical resources for the design, layout, fabrication, and assembly of the EZ-KIT Lite.

For information on the graphical user interface, including the boot loading, target options, and other facilities of the EZ-KIT Lite system, refer to the online help.

For detailed information on how to program the ADSP-21371 SHARC processor, refer to the documents referenced in [“Related Documents”](#).

## Package Contents

Your ADSP-21371 EZ-KIT Lite evaluation system package contains the following items.

- ADSP-21371 EZ-KIT Lite board
- Universal 7V DC power supply
- USB 2.0 cable

## Using the ADSP-21371 EZ-KIT Lite

- 3.5 mm stereo headphones
- 6-foot RCA audio cable
- 6-foot 3.5 mm/RCA x 2 Y-cable

If any item is missing, contact the vendor where you purchased your EZ-KIT Lite or contact Analog Devices, Inc.

## Default Configuration

The EZ-KIT Lite evaluation system contains ESD (electrostatic discharge) sensitive devices. Electrostatic charges readily accumulate on the human body and equipment and can discharge without detection. Permanent damage may occur on devices subjected to high-energy discharges. Proper ESD precautions are recommended to avoid performance degradation or loss of functionality. Store unused EZ-KIT Lite boards in the protective shipping package.



The ADSP-21371 EZ-KIT Lite board is designed to run outside your personal computer as a standalone unit. You do not have to open your computer case.

When removing the EZ-KIT Lite board from the package, handle the board carefully to avoid the discharge of static electricity, which may damage some components. [Figure 1-1](#) shows the default jumper settings, DIP switch, connector locations, and LEDs used in installation. Confirm that your board is set up in the default configuration before continuing.

## CCES Install and Session Startup

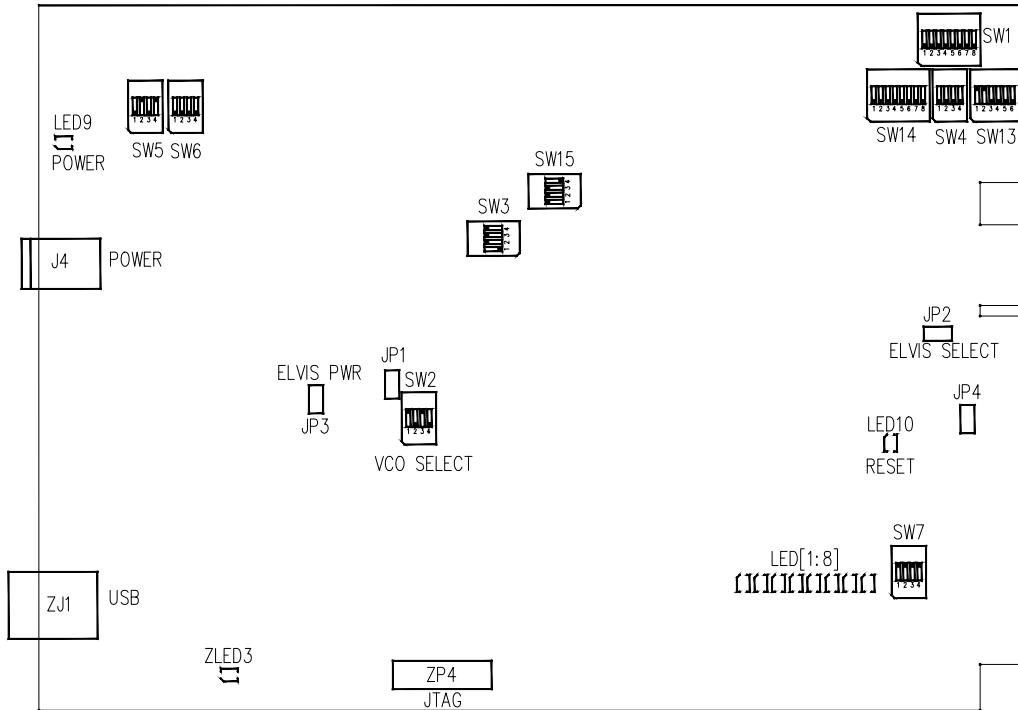

Figure 1-1. EZ-KIT Lite Hardware Setup

## CCES Install and Session Startup

For information about CCES and to download the software, go to [www.analog.com/CCES](http://www.analog.com/CCES). A link for the ADSP-21371 EZ-KIT Lite Board Support Package (BSP) for CCES can be found at <http://www.analog.com/SHARC/EZKits>.

Follow these instructions to ensure correct operation of the product software and hardware.

## Using the ADSP-21371 EZ-KIT Lite

**Step 1:** Connect the EZ-KIT Lite board to a personal computer (PC) running CCES using one of two options: an Analog Devices emulator or via the debug agent.

### Using an Emulator:

1. Plug one side of the USB cable into the USB connector of the emulator. Plug the other side into a USB port of the PC running CCES.
2. Attach the emulator to the header connector ZP4 (labeled JTAG) on the EZ-KIT Lite board.

### Using the on-board Debug Agent:

1. Plug one side of the USB cable into the USB connector of the debug agent ZJ1 (labeled USB).
2. Plug the other side of the cable into a USB port of the PC running CCES.

**Step 2:** Attach the provided cord and appropriate plug to the 7V power adaptor.

1. Plug the jack-end of the power adaptor into the power connector J4 on the EZ-KIT Lite board.
2. Plug the other side of the power adaptor into a power outlet. The power LED (labeled LED9) is lit green when power is applied to the board.
3. Power the emulator (if used). Plug the jack-end of the assembled power adaptor into the emulator and plug the other side of the power adaptor into a power outlet. The enable/power indicator is lit green when power is applied.

## CCES Install and Session Startup

**Step 3 (if connected through the debug agent):** Verify that the yellow USB monitor LED (labeled ZLED3) and the green power LED (labeled ZLED9) on the debug agent are both on. This signifies that the board is communicating properly with the host PC and ready to run CCES.

## Session Startup

It is assumed that the CrossCore Embedded Studio software is installed and running on your PC.

 Note: If you connect the board or emulator first (before installing CCES) to the PC, the Windows driver wizard may not find the board drivers.

1. Navigate to the CCES environment via the **Start** menu.

Note that CCES is not connected to the target board.

2. Use the system configuration utility to connect to the EZ-KIT Lite board.

If a debug configuration exists already, select the appropriate configuration and click **Apply and Debug** or **Debug**. Go to step 8.

To create a debug configuration, do one of the following:

- Click the down arrow next to the little bug icon, select **Debug Configurations**
- Choose **Run > Debug Configurations**.

The **Debug Configuration** dialog box appears.

3. Select **CrossCore Embedded Studio Application** and click  (New launch configuration).

The **Select Processor** page of the **Session Wizard** appears.



## Using the ADSP-21371 EZ-KIT Lite

4. Ensure **Blackfin** is selected in **Processor family**. In **Processor type**, select **ADSP-21371**. Click **Next**.

The **Select Connection Type** page of the **Session Wizard** appears.

5. Select one of the following:
  - For standalone debug agent connections, **EZ-KIT Lite** and click **Next**.
  - For emulator connections, **Emulator** and click **Next**.

The **Select Platform** page of the **Session Wizard** appears.



6. Do one of the following:
  - For standalone debug agent connections, ensure that the selected platform is **ADSP-21371 EZ-KIT Lite** via **Debug Agent**.
  - For emulator connections, choose the type of emulator that is connected to the board.
7. Click **Finish** to close the wizard.

The new debug configuration is created and added to the program(s) to load list.

8. In the **Program(s) to load** section, choose the program to load when connecting to the board. If not loading any program upon connection to the target, do not make any changes.

Note that while connected to the target, there is no way to choose a program to download. To load a program once connected, terminate the session.

## VisualDSP++ Install and Session Startup

 To delete a configuration, go to the **Debug Configurations** dialog box and select the configuration to delete. Click  and choose **Yes** when asked if you wish to delete the selected launch configuration. Then **Close** the dialog box.

 To disconnect from the target board, click the terminate button (red box) or choose **Run > Terminate**.

To delete a session, choose **Target > Session > Session List**. Select the session name from the list and click **Delete**. Click **OK**.

## VisualDSP++ Install and Session Startup

For information about VisualDSP++ and to download the software, go to [www.analog.com/VisualDSP](http://www.analog.com/VisualDSP).

1. Plug the provided power supply into J4 on the EZ-KIT Lite board. Visually verify that the green power LED (LED9) is on.
2. Verify that the red reset LED (LED10) goes on for a moment and then goes off, and, finally, LED1 through LED8 are blinking sequentially.
3. Connect one end of the USB cable to an available full speed USB port on your PC and the other end to ZJ1 on the ADSP-21371 EZ-KIT Lite board
4. Verify that the yellow USB monitor LED (ZLED3, located near the USB connector) is lit. This signifies that the board is communicating properly with the host PC and is ready to run VisualDSP++.

## Session Startup

1. If you are running VisualDSP++ for the first time, navigate to the VisualDSP++ environment via the **Start > Programs** menu. The main window appears. Note that VisualDSP++ does not connect to any session. Skip the rest of this step to step 2.

If you have run VisualDSP++ previously, the last opened session appears on the screen. You can override the default behavior and force VisualDSP++ to start a new session by pressing and holding down the **Ctrl** key while starting VisualDSP++. Do not release the **Ctrl** key until the **Session Wizard** appears on the screen. Go to step 3.

2. To connect to a new EZ-KIT Lite session, start **Session Wizard** by selecting one of the following.
  - From the **Session** menu, **New Session**.
  - From the **Session** menu, **Session List**. Then click **New Session** from the **Session List** dialog box.
  - From the **Session** menu, **Connect to Target**.
3. The **Select Processor** page of the wizard appears on the screen. Ensure **SHARC** is selected in **Processor family**. In **Choose a target processor**, select **ADSP-21371**. Click **Next**.
4. The **Select Connection Type** page of the wizard appears on the screen. Select **EZ-KIT Lite** and click **Next**.

## CCES Evaluation License

5. The **Select Platform** page of the wizard appears on the screen. Ensure that the selected platform is **ADSP-21371 EZ-KIT Lite via Debug Agent**. Specify your own **Session name** for your session or accept the default name.

The session name can be a string of any length; although, the box displays approximately 32 characters. The session name can include space characters. If you do not specify a session name, VisualDSP++ creates a session name by combining the name of the selected platform with the selected processor. The only way to change a session name later is to delete the session and open a new session. Click **Next**.

6. The **Finish** page of the wizard appears on the screen. The page displays your selections. Check the selections. If you are not satisfied, click **Back** to make changes; otherwise, click **Finish**. VisualDSP++ creates the new session and connects to the EZ-KIT Lite. Once connected, the main window's title is changed to include the session name set in step 5.



To disconnect from a session, click the disconnect button  or select **Session > Disconnect from Target**.

To delete a session, select **Session > Session List**. Select the session name from the list and click **Delete**. Click **OK**.

## CCES Evaluation License

The ADSP-21371 EZ-KIT Lite software is part of the Board Support Package (BSP) for the SHARC ADSP-2137x family. The EZ-KIT Lite is a licensed product that offers an unrestricted evaluation license for 90 days after activation. Once the evaluation period ends, the evaluation license becomes permanently disabled. If the evaluation license is installed but

## Using the ADSP-21371 EZ-KIT Lite

not activated, it allows 10 days of unrestricted use and then becomes disabled. The license can be re-enabled by activation.

An evaluation license can be upgraded to a full license. Licenses can be purchased from:

- Analog Devices directly. Call (800) 262-5645 or 781-937-2384 or go to:  
<http://www.analog.com/buyonline>.
- Analog Devices, Inc. local sales office or authorized distributor. To locate one, go to:  
<http://www.analog.com/salesdir/continent.asp>.

 The EZ-KIT Lite hardware must be connected and powered up to use CCES with a valid evaluation or full license.

## VisualDSP++ Evaluation License

The ADSP-21371 EZ-KIT Lite installation is part of the VisualDSP++ installation. The EZ-KIT Lite is a licensed product that offers an unrestricted evaluation license for the first 90 days. Once the initial unrestricted 90-day evaluation license expires:

1. VisualDSP++ allows a connection to the ADSP-21371 EZ-KIT Lite via the USB Debug Agent interface only. Connections to simulators and emulation products are no longer allowed.
2. The linker restricts a user program to 5325 words of memory for code space with no restrictions for data space.

 To avoid errors when opening VisualDSP++, the EZ-KIT Lite hardware must be connected and powered up. This is true for using VisualDSP++ with a valid evaluation or full license.

## External Memory

# External Memory

The EZ-KIT Lite contains three types of memory: parallel flash (1 MB), SPI flash (2M bit), and SDRAM (128M bit). Flash memories can store user-specific boot code and allow the board to run as a standalone unit. For information on how to select a boot device for the processor, see [“Boot Mode and Clock Ratio Select Switch \(SW2\)”](#) on page 2-9.

Table 1-1 provides start and end addresses of the on-board external memories.

Table 1-1. EZ-KIT Lite Evaluation Board External Memory

Start Address	End Address	Content
0x00200000	0x9FFFFFFF	SDRAM memory ( $\overline{MS0}$ )
0x04000000	0x040FFFFFFF	Flash memory ( $\overline{MS1}$ )
0x08000000 0x08000000	0x08FFFFFFF 0x0BFFFFFFF	Unused chip select ( $\overline{MS2}$ ) for non-SDRAM addresses Unused chip select ( $\overline{MS2}$ ) for SDRAM address
0x0C000000 0x0C000000	0x0CFFFFFFF 0x0FFFFFFF	Unused chip select ( $\overline{MS3}$ ) for non-SDRAM addresses Unused chip select ( $\overline{MS3}$ ) for SDRAM addresses

Parallel flash memory and SDRAM are connected to the external memory of the processor.

SDRAM memory is connected to the SDRAM controller of the processor. A set of programmable timing parameters is available to configure the SDRAM banks to support slower memory accesses. Care must be taken when configuring the SDRAM control registers. For more information regarding the SDRAM controller setup, refer to the *ADSP-2137x SHARC Processor Hardware Reference*.

An example program is included in the EZ-KIT Lite installation directory to demonstrate the controller setup.

## Using the ADSP-21371 EZ-KIT Lite

SPI flash memory is connected to the SPI port of the processor; SPI flash designates:

- DPI pin 5 (DPI5) as a chip select
- DPI pin 3 (DPI3) as the SPI clock
- DPI pin 1 (DPI1) as the MOSI
- DPI pin 2 (DPI2) as the MISO

By default, the DPI is set up for SPI flash, and any required changes to SPI flash can be made by modifying the DPI interface of the processor. An example program is included in the EZ-KIT Lite installation directory to demonstrate SPI flash memory reads and writes.

Parallel flash memory is connected to the asynchronous memory controller of the processor. Each of their respective memory banks can be programmed independently with different timing parameters. For more information on changing wait states to speed up or slow down the asynchronous controller and other setup information, refer to the *ADSP-2137x SHARC Processor Hardware Reference*.

Example programs are included in the EZ-KIT Lite installation directory to demonstrate flash memory reads and writes.

## ELVIS Interface

The ADSP-21371 EZ-KIT Lite board contains the National Instruments Educational Laboratory Virtual Instrumentation Suite interface. The interface features the DC voltage and current measurement modules, oscilloscope and bode analyzer modules, function generator, arbitrary waveform generator, and digital I/O.

The ELVIS interface is a LabVIEW-based design and prototype environment for university science and engineering laboratories. The ELVIS

## Analog Audio

interface consists of LabVIEW-based virtual instruments, a multifunction data acquisition (DAQ) device, and a custom-designed bench-top workstation and prototype board. This combination provides a ready-to-use suite of instruments found in most educational laboratories. Because the interface is based on LabVIEW and provides complete data acquisition and prototyping capabilities, the system is ideal for academic coursework that range from lower-division classes to advanced project-based curriculums.

For more information on ELVIS and example demonstration programs, visit National Instruments Web site at [www.ni.com](http://www.ni.com).

## Analog Audio

The AD1835A device is a high-performance, single-chip codec featuring four stereo digital-to-analog converters (DACs) for audio output and one stereo analog-to-digital converters (ADCs) for audio input. The codec can input and output data with a sample rate of up to 96 kHz on all channels. A 192 kHz sample rate can be used with one of the DAC channels.

The processor is interfaced with the AD1835A codec via the DAI port. The DAI pins can be configured to transfer serial data from the codec in either time-division multiplexed (TDM) or 2-wire interface mode (TWI). For more information about the AD1835A connection to the DAI, see “[DAI Interface](#)” on page 2-3.

The master input clock (MCLK) for the AD1835A codec can be generated by the on-board 12.288 MHz oscillator or supplied by one of the DAI pins of the processor. Using a DAI pin to generate the MCLK, as opposed to the on-board oscillator, allows synchronization of multiple devices in the system. It is possible to disable the on-board audio oscillator from driving the audio codec and the processor’s input pin. For instructions on how to configure the clock, refer to “[Codec Setup Switch \(SW3\)](#)” on page 2-10.



## Using the ADSP-21371 EZ-KIT Lite

The AD1835A codec can be configured as a master or a slave, depending on the DIP switch settings. In master mode, the codec drives the serial port clock and frame sync signals to the processor. In slave mode, the processor must generate and drive all of the serial port clock and frame sync signals. For more information, refer to [“Codec Setup Switch \(SW3\)” on page 2-10](#).

The internal configuration registers of the AD1835A codec are configured using the SPI port of the processor. The DPI pin 4 (DPI4 register) is used as the select for the device. For information on how to configure the multichannel codec, refer to the product data sheet at [AD1835A](#).

The RCA connector (J10) is used to input analog audio. When using an electret microphone on this connector, configure switch SW4 according to the instructions in [“Electret Microphone Select Switch \(SW4\)” on page 2-11](#). The four output channels are connected to the RCA connector (J5). Channel 4 of the codec connects to the headphone jack (J9). For more information, see [“Connectors” on page 2-20](#).

Example programs are included in the EZ-KIT Lite installation directory to demonstrate how to configure and use the on-board analog audio interface.

## LEDs and Push Buttons

The EZ-KIT Lite has eight general-purpose user LEDs and four general-purpose push buttons.

Two general-purpose push buttons are attached to the FLAG pins of the processor, while the other two are attached to the DAI pins. All of the push buttons are connected to the processor through a DIP switch (SW7). The DIP switch can disconnect the processor pins connected to the push buttons. See [“Push Button Enable Switch \(SW7\)” on page 2-12](#) for

## LEDs and Push Buttons

instructions on how to disable a push button from driving its associated processor pin.

The state of the push buttons connected to the FLAG pins can be determined by reading the FLAG register. The push buttons connected to the DAI pins must be configured as interrupts. It is necessary to set up an interrupt routine to determine each pin's state. [Table 1-2](#) shows the push button and processor connections. Refer to the related example program shipped with the EZ-KIT Lite for more information.

Table 1-2. Push Button Connections

Push Button Label	Push Button Reference Designator	Processor Pin
PB1	SW8	FLAG1/ $\overline{IRQ1}$
PB2	SW11	FLAG0/ $\overline{IRQ0}$
PB3	SW10	DAI19
PB4	SW9	DAI20

[Table 1-3](#) summarizes the LED connections to the processor. To use the LEDs connected to the DAI or DPI pins, configure the respective processor's registers. For more information, refer to the *ADSP-2137x SHARC Processor Hardware Reference*.

Table 1-3. LED Connections

LED Reference Designator	Processor Pin
LED1	DPI6
LED2	DPI7
LED3	DPI8
LED4	DPI13
LED5	DPI14
LED6	DAI15

Table 1-3. LED Connections (Cont'd)

LED Reference Designator	Processor Pin
LED7	DA116
LED8	FLAG3/MS3/TRQ3

An example program is included in the EZ-KIT Lite installation directory to demonstrate functionality of the LEDs and push buttons.

## Example Programs

Example programs are provided with the ADSP-21371 EZ-KIT Lite to demonstrate various capabilities of the product. The programs are included in the product installation kit and can be found in the `Examples` folder of the installation. Refer to a readme file provided with each example for more information.

CCES users are encouraged to use the example browser to find examples included with the EZ-KIT Lite Board Support Package.

## Board Design Database

A `.zip` file containing all of the electronic information required for the design, layout, fabrication and assembly of the product is available for download from the Analog Devices board design database at:  
<http://www.analog.com/sharc-board-design-database>.

## Board Design Database

## 2 ADSP-21371 EZ-KIT LITE HARDWARE REFERENCE

This chapter describes the hardware design of the ADSP-21371 EZ-KIT Lite board.

The following topics are covered.

- [“System Architecture” on page 2-2](#)  
Describes the ADSP-21371 board configuration and explains how the board components interface with the processor.
- [“Switches” on page 2-8](#)  
Shows the locations and describes the on-board switches.
- [“LEDs and Push Buttons” on page 2-14](#)  
Shows the locations and describes the on-board LEDs and push buttons.
- [“Jumpers” on page 2-17](#)  
Shows the locations and describes the on-board configuration jumpers.
- [“Connectors” on page 2-20](#)  
Shows the locations and provides part numbers for the on-board connectors. In addition, the manufacturer and part number information is provided for the mating parts.

## System Architecture

# System Architecture

This section describes the processor's configuration on the EZ-KIT Lite board (Figure 2-1).

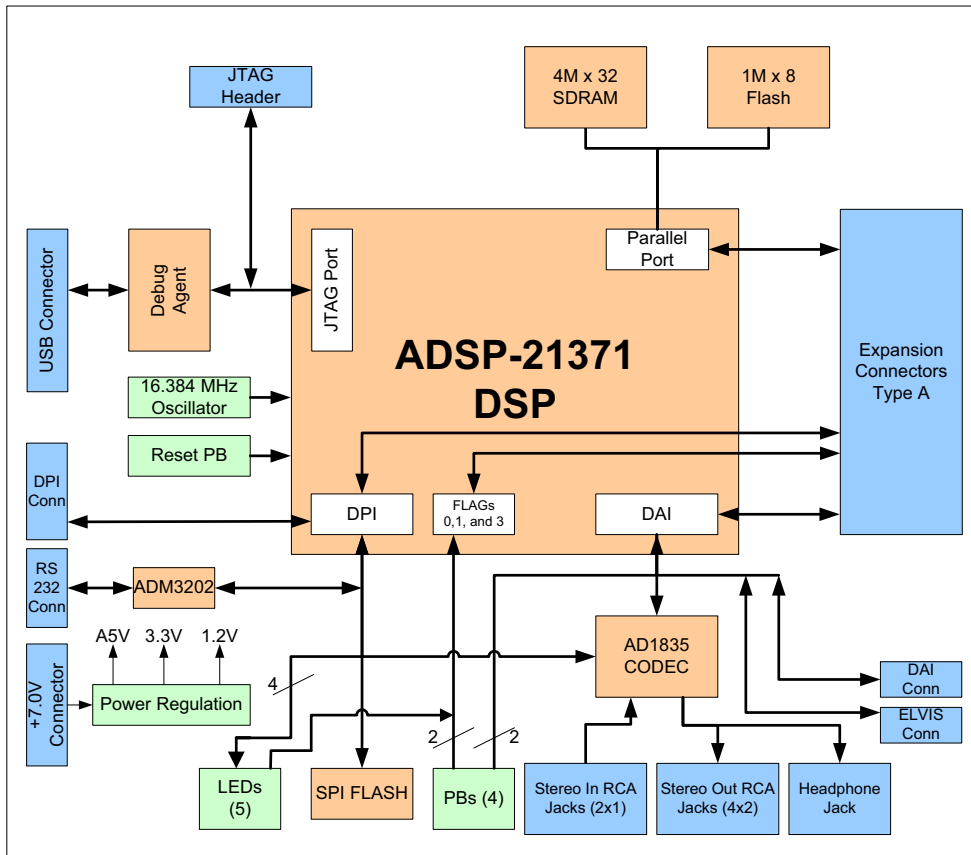

Figure 2-1. System Architecture Block Diagram

The EZ-KIT Lite is designed to demonstrate the ADSP-21371 processor capabilities. The processor core is powered at 1.2V, and the I/O is powered at 3.3V.

## ADSP-21371 EZ-KIT Lite Hardware Reference

The CLKIN pin of the processor connects to a 16.384 MHz oscillator. The core frequency of the processor is derived by multiplying the frequency at the CLKIN pin by a value determined by the state of the processor pins CLKCFG1 and CLKCFG0. The value at these pins is determined by the state of switch SW2 (see [“Boot Mode and Clock Ratio Select Switch \(SW2\)” on page 2-9](#)). By default, the EZ-KIT Lite provides a core frequency of 262.144 MHz. It is possible to change the speed of the processor by changing the value of the PMCTL register.

The SW2 switch also configures the boot mode of the processor. The EZ-KIT Lite is capable of EPROM/flash boot and SPI boot. By default, the EZ-KIT Lite boots from flash memory. For details, see [“Boot Mode and Clock Ratio Select Switch \(SW2\)” on page 2-9](#).

### External Port

The external port of the ADSP-21371 processor consists of a 24-bit address bus, 16-bit data memory bus, and control lines. The control lines are used to select, read, and write to external memory devices.

The external port connects to an 8-bit parallel flash memory and a 16-bit SDRAM memory. See [“External Memory” on page 1-12](#) for more information about accessing flash and SDRAM memories.

All of the external port signals are available externally via the expansion interface connectors (J1–3). The pinout of the connectors can be found in [“ADSP-21371 EZ-KIT Lite Schematic” on page B-1](#).

### DAI Interface

The digital application interface (DAI) pins are connected to the signal routing unit (SRU) of the processor. The SRU is a flexible routing system, providing a large system of signal flows within the processor. In general, the SRU can route the DAI pins to different internal peripherals in various combinations.

## System Architecture

The DAI pins are connected to the AD1835A audio codec, a 26-pin header, two RCA connectors, audio oscillator output, an external phase lock loop (PLL) circuit, two LEDs, and two push buttons. [Figure 2-2](#) illustrates the EZ-KIT Lite's connections to the DAI interface.

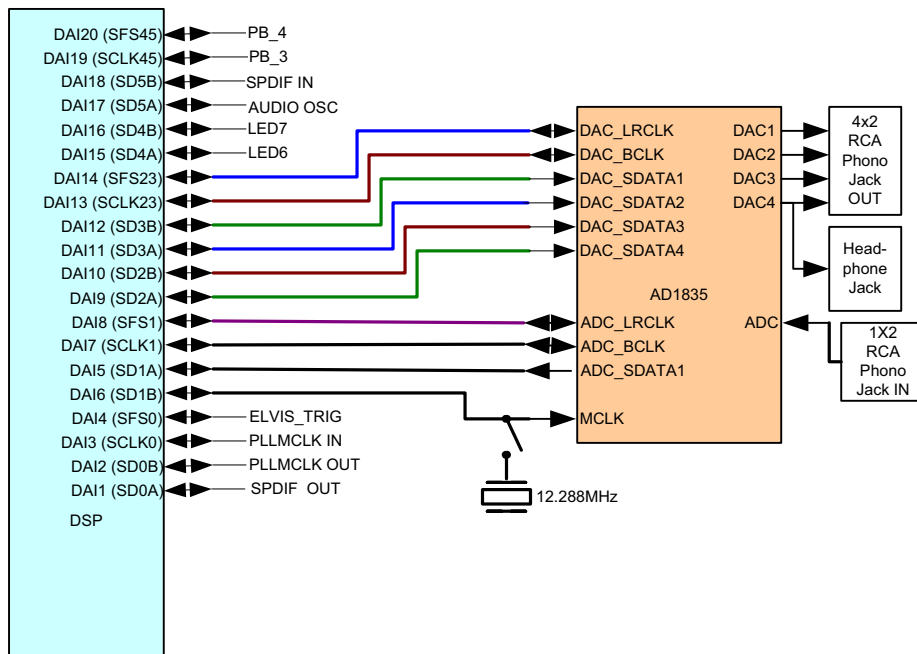

Figure 2-2. DAI Connections Block Diagram

To use the DAI for a different purpose, disable any signal driving a DAI pin with a switch (see [“Codec Setup Switch \(SW3\)”](#) on page 2-10). In addition, SW3 enables flexible routing of the 12.288 MHz audio oscillator’s output signal. By default, the SW3 signal is used as the master clock (MCLK) for the AD1835A codec.

All of the DAI signals are available externally via the expansion interface connectors (J1–3) and 0.1” spaced header (P4). The pinout of the connectors can be found in [“ADSP-21371 EZ-KIT Lite Schematic”](#) on page B-1.



## DPI Interface

The digital peripheral interface (DPI) pins are connected to a second signal routing unit of the processor (SRU2). The SRU2 unit, similar to the SRU, is a flexible routing system, providing a large system of signal flows within the processor. In general, the SRU2 can route the DPI pins to different internal peripherals in various combinations.

The DPI pins are connected to the SPI flash memory, SPI of the AD1835A codec, a UART, a 20-pin header, and five LEDs. [Figure 2-3](#) illustrates the EZ-KIT Lite's connections to the DPI interface.

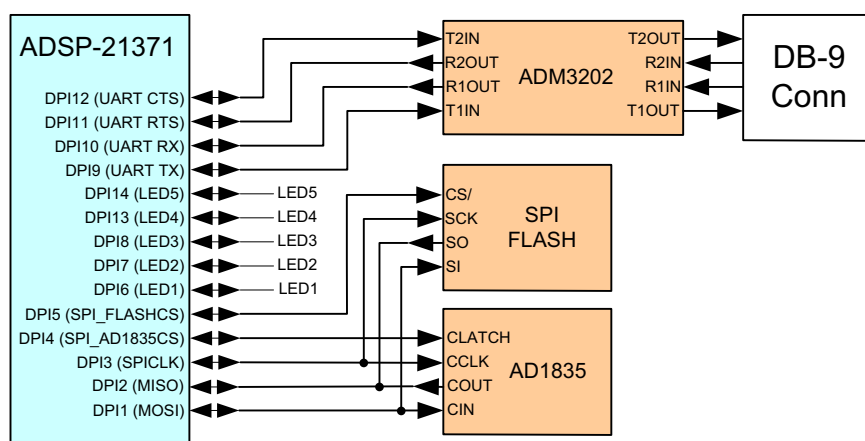

Figure 2-3. DPI Connections Block Diagram

To use the DPI for a different purpose, disable any signal driving a DPI pin with a switch (see [“UART Enable Switch \(SW5\)”](#) on page 2-11). Any DPI pin connected to a LED can be used without having to disconnect the pin. You can, however, see the respective LED turn ON and OFF when the signal is used elsewhere on the board.

## System Architecture

All of the DPI signals are available externally via the expansion interface connectors (J1–3) and 0.1” spaced header (P3). The pinout of the connectors can be found in [“ADSP-21371 EZ-KIT Lite Schematic” on page B-1](#).

## FLAG Pins

The processor has four general-purpose I/O flag pins. [Table 2-1](#) describes the flag pin connections.

Table 2-1. I/O FLAG Pins

Processor FLAG Pin	EZ-KIT Lite Function
FLAG0	Push button (SW2) input
FLAG1	Push button (SW2) input
FLAG2	SDRAM chip select
FLAG3	LED8

For information on how to disable a push button from driving its associated flag pin, see [“Push Button Enable Switch \(SW7\)” on page 2-12](#).

The FLAG signals are available externally via the expansion interface connectors (J1–3). The pinout of the connectors can be found in [“ADSP-21371 EZ-KIT Lite Schematic” on page B-1](#).

## External PLL

The ADSP-21371 EZ-KIT Lite contains an external phase lock loop to help generate a faster and more stable master input clock, MCLK. The PLL uses DAI pin 3 as an input clock from the ADSP-21371 processor. The new clock generated by PLL connects to the processor via DAI pin 2.

Example programs are included in the EZ-KIT Lite installation directory to demonstrate how to configure and use the board’s external PLL.

## Expansion Interface

The expansion interface consists of three 90-pin connectors. [Table 2-2](#) shows the interfaces each connector provides. For the exact pinout of the connectors, refer to [“ADSP-21371 EZ-KIT Lite Schematic” on page B-1](#). The mechanical dimensions of the connectors can be obtained from [Technical Support](#).

Table 2-2. Expansion Interface Connectors

Connector	Interfaces
J1	5V, ADDR23-0, DATA31-0
J2	3.3V, FLAG3-0, DAIP20-1, DPI14-1, SDRAM control signals
J3	5V, 3.3V, reset, parallel port control signals

Limits to current and interface speed must be taken into consideration when using the expansion interface. The maximum current limit is dependent on the capabilities of the used regulator. Additional circuitry also can add extra loading to signals, decreasing their maximum effective speed.



Analog Devices does not support and is not responsible for the effects of additional circuitry.

## JTAG Emulation Port

The JTAG emulation port allows an emulator to access the internal and external memory of the processor through a 6-pin interface. The JTAG emulation port of the processor also connects to the USB debugging interface. When an emulator connects to the board at ZP4, the USB debugging interface is disabled. This is not a standard connection of the JTAG interface.

## Switches

For information about the standard connection of the interface, see *EE-68* published on the Analog Devices Web site. For more information about the JTAG connector, see “[JTAG Header \(ZP4\)](#)” on page 2-24. To learn more about SHARC processor emulators, go to <http://www.analog.com/processors/tools/sharc>.

## Switches

This section describes operation of the on-board switches. The switch locations and default settings are shown in [Figure 2-4](#).

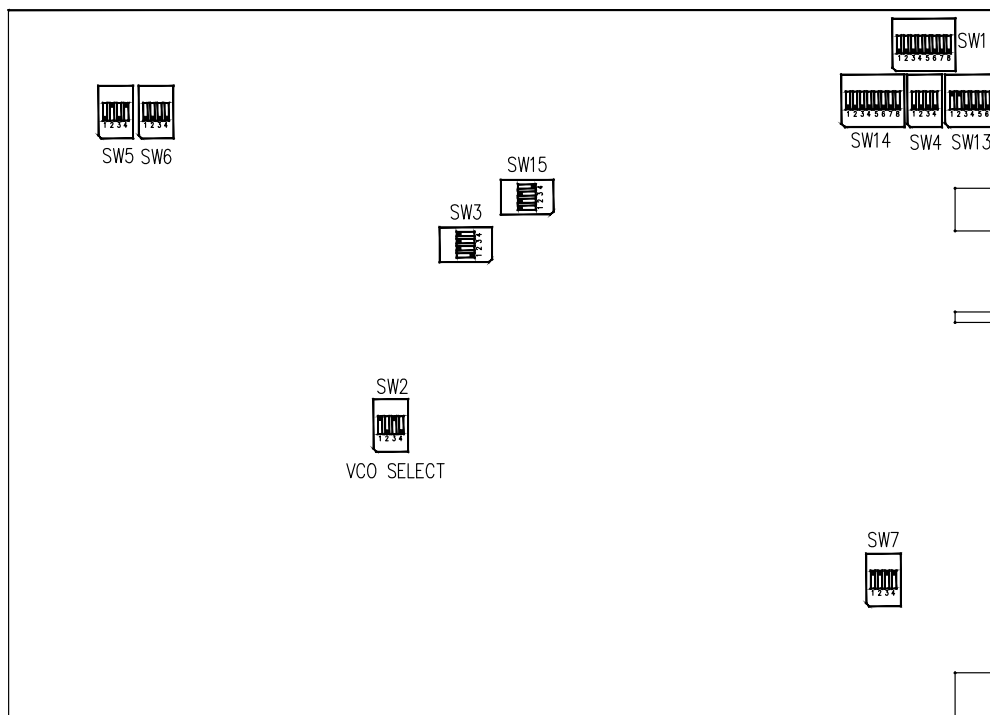

Figure 2-4. Switch Locations and Default Settings

## Boot Mode and Clock Ratio Select Switch (SW2)

The SW2 switch sets the boot mode and lock multiplier ratio of the processor. [Table 2-3](#) shows how to set up the boot mode using SW2 positions 1 and 2. By default, the EZ-KIT Lite boots in external port mode from flash memory.

Table 2-3. Boot Mode Configuration

BOOTCFG0 Pin (Position 1)	BOOTCFG1 Pin (Position 2)	Boot Mode
ON	ON	SPI slave boot
<b>ON</b>	<b>OFF</b>	<b>Parallel flash boot (default)</b>
OFF	ON	SPI master boot
OFF	OFF	Reserved

[Table 2-4](#) shows how to set up the clock multiply ratio using SW2 positions 3 and 4. By default, the processor increases the clock multiply ratio by sixteen, setting the core clock to 262.144 MHz.

Table 2-4. Core Clock Rate Configuration

CLKCFG0 (Position 3)	CLKCFG1 (Position 4)	Core to CLKIN Ratio
ON	ON	6:1
<b>ON</b>	<b>OFF</b>	<b>16:1 (default)</b>
OFF	ON	32:1
OFF	OFF	Reserved

The core clock frequency can be increased or decreased via software by writing to the PMCTL register. For more information on changing the core clock frequency and other setup information, refer to the *ADSP-2137x SHARC Processor Hardware Reference*.

## Switches

### Codec Setup Switch (SW3)

The codec setup switch (SW3) can be used to change the routing of some signals going to the AD1835A codec and set up the communication protocol of the codec.

SW3 positions 1 and 2 determine the clock routing for the audio oscillator to the codec and processor. [Figure 2-5](#) illustrates how the switch positions 1 and 2 connect on the board. In the default position, route the DAI\_P17 pin to DAI\_P6 (in software) to clock the codec.

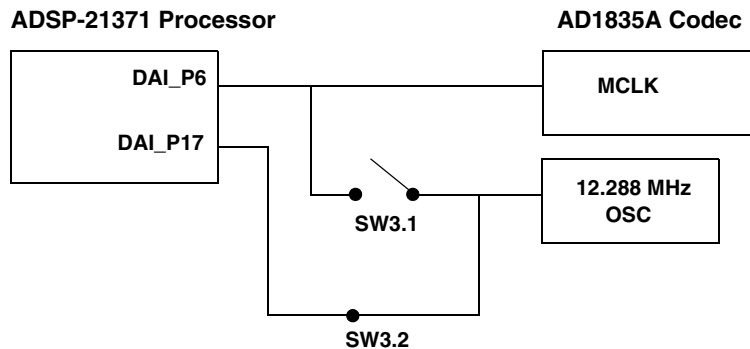

Figure 2-5. Audio Clock Routing

SW3 position 3 determines if the AD1835A device is a master or a slave. If the AD1835A is a master, the device's serial interface generates the frame sync and clock signals necessary to transfer data. When the device is a slave, the processor must generate the frame sync and clock signals. By default, position 3 is ON, and the AD1835A codec generates the control signals.

SW3 position 4 disconnects the AD1835A's ADC\_DATA pin from the DAI. This is useful when the DAI is connected to another device.

### Electret Microphone Select Switch (SW4)

To connect an electret microphone to audio input, place all positions of SW4 ON. The default switch position is all OFF. When SW4 is all ON, a DC offset of 2.5V is added to the signal, and gain of the input amplifiers is changed from 1x to 10x.

### UART Enable Switch (SW5)

The UART enable switch (SW5) disconnects the UART signals from the DPI pins of the processor. When SW5 is OFF, its associated DPI signal (see [Table 2-5](#)) can be used on the expansion interface.

Table 2-5. UART Enable Switch (SW5)

Switch Position	EZ-KIT Lite Signal	Processor Signal
1 (OFF <sup>1</sup> )	CTS	DPI12
2 (ON)	RX	DPI10
3 (OFF)	RTS	DPI11
4 (ON)	T2IN tied to R2OUT	N/A

<sup>1</sup> Bold typeface denotes the default setting.

### Loopback Test Switches (SW6 and SW14)

The loopback test switch (SW6) is located at the top left side of the board. The second loopback test switch (SW14) is located at the top right side of the board. These switches are used for testing only; all switch positions should remain OFF.

## Switches

### Push Button Enable Switch (SW7)

The push button enable switch (SW7) disconnects the push buttons from their respective processor pins. This allows the signals to be used elsewhere on the board. [Table 2-6](#) shows the switch connections. By default, all positions of SW7 are ON, and the push buttons function as designed.

Table 2-6. Push Button Enable Switch (SW7)

Switch Position	Push Button Label	Push Button Reference Designator	Processor Pin
1	PB1	SW8	FLAG1/ $\overline{TRQ}$
2	PB2	SW11	FLAG0/ $\overline{TRQ0}$
3	PB3	SW10	DAI19
4	PB4	SW9	DAI20

### ELVIS Oscilloscope Configuration Switch (SW1)

The oscilloscope configuration switch (SW1) determines which audio circuit signals connect to channels A and B of the oscilloscope. The switch is used only when the board is connected to the Educational Laboratory Virtual Instrumentation Suite (ELVIS) station; see [“ELVIS Interface” on page 1-13](#). Each channel must have only one signal selected at a time, as described in [Table 2-7](#).

Table 2-7. Oscilloscope Configuration Switch (SW1)

Channel	Switch Position	Audio Circuit Signal
A	1 (OFF <sup>1</sup> )	AMP_LEFT_IN
A	2 (OFF)	AMP_RIGHT_IN
A	3 (OFF)	LEFT_OUT
A	4 (OFF)	RIGHT_OUT
B	5 (OFF)	AMP_LEFT_IN
B	6 (OFF)	AMP_RIGHT_IN



## ADSP-21371 EZ-KIT Lite Hardware Reference

Table 2-7. Oscilloscope Configuration Switch (SW1) (Cont'd)

Channel	Switch Position	Audio Circuit Signal
B	7 (OFF)	LEFT_OUT
B	8 (OFF)	RIGHT_OUT

1 Bold typeface denotes the default settings.

### ELVIS Function Generator Configuration Switch (SW13)

The function generator configuration switch (SW13) controls which signals connect to the left and right input signals of the audio interface. The SW13 switch is used only when the board is connected to the ELVIS station; see [“ELVIS Interface” on page 1-13](#). Each channel must have only one signal selected at a time, as described in [Table 2-8](#).

Table 2-8. ELVIS Function Generator Configuration Switch (SW13)

Channel	Switch Position	Audio Signal
AMP_LEFT_IN	1 (ON <sup>1</sup> )	LEFT_IN
AMP_RIGHT_IN	2 (ON)	RIGHT_IN
AMP_LEFT_IN	3 (OFF)	DAC0
AMP_RIGHT_IN	4 (OFF)	DAC1
AMP_LEFT_IN	5 (OFF)	FUNCT_OUT
AMP_RIGHT_IN	6 (OFF)	FUNCT_OUT

1 Bold typeface denotes the default settings.

## LEDs and Push Buttons

### AD1835A and Flash Disconnect Switch (SW15)

The AD1835A and flash disconnect switch (SW15) disconnects the following signals: DPI4\_SPI\_AD1835\_CS, DAIP8\_ADC\_LRCLK, and DPI5\_SPI\_FLASH\_CS. The switch is used only on the expansion interface. By default, SW15 positions 1–3 are ON and position 4 is OFF.

## LEDs and Push Buttons

This section describes the on-board LEDs and push buttons. The LED and push button locations are shown in [Figure 2-6](#).

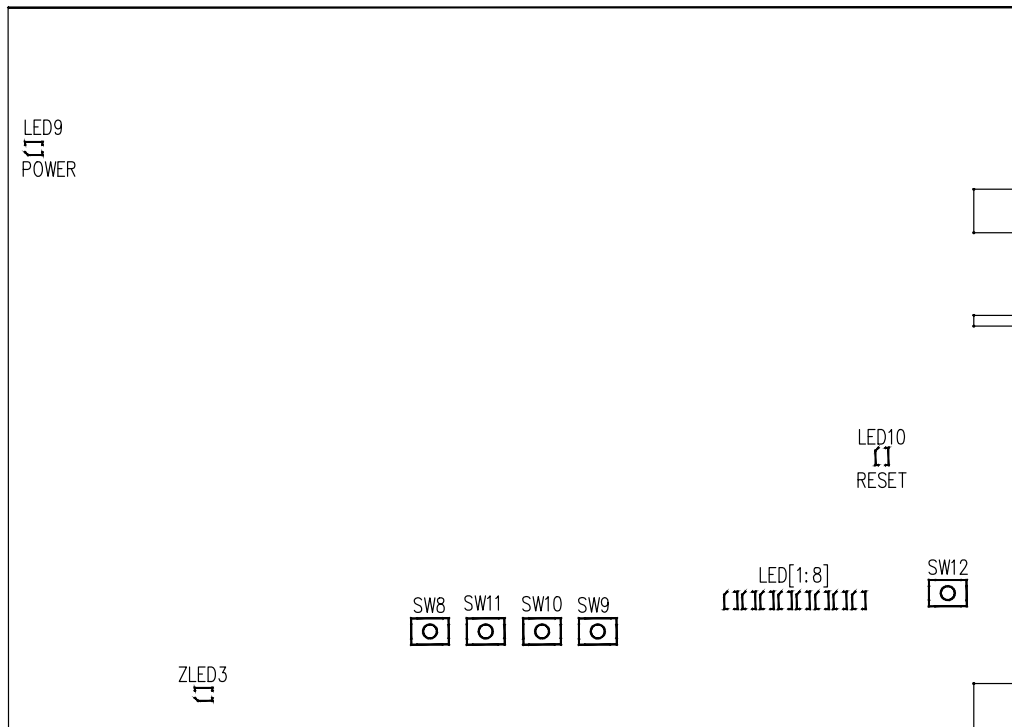

Figure 2-6. LED and Push Button Locations

### General Purpose LEDs (LED1–8)

There are eight general-purpose LEDs on the board. Five LEDs are connected to the DPI interface, two LEDs are connected to the DAI interface, and one LED is connected to `FLAG3` of the processor. “[LEDs and Push Buttons](#)” on page 1-15 summarizes the LED connections. To use an LED connected to the DAI or DPI, program its respective register on the processor. For more information on how to program the registers, refer to the *ADSP-2137x SHARC Processor Hardware Reference*.

### Power LED (LED9)

When `LED9` is lit (green), it indicates that power is supplied to the board.

### Reset LED (LED10)

When `LED10` is lit (red), a master reset of all the major ICs is active.

### USB Monitor LED (ZLED3)

The USB monitor LED (`ZLED3`) indicates that USB communication has been initialized successfully, and you can connect to the processor using an EZ-KIT Lite session. Once the USB cable is plugged into the board, it takes approximately 15 seconds for the USB monitor LED to light. If the LED does not light, try cycling power on the board and/or reinstalling the USB driver.



When the development software is actively communicating with the EZ-KIT Lite target board, the LED can flicker, indicating communications handshake.

## LEDs and Push Buttons

### Push Buttons (SW8–11)

Four push buttons (SW8–11) are provided for general-purpose user input. Two push buttons are connected to the FLAG pins of the processor, while the other two are connected to the DAI of the processor. The push buttons are active high and, when pressed, send a high (1) to the processor. Refer to [“LEDs and Push Buttons” on page 1-15](#) for more information. The push button enable switch (SW7) is capable of disconnecting the push buttons from corresponding processor pins. Refer to [“Push Button Enable Switch \(SW7\)” on page 2-12](#) for more information.

The push buttons and corresponding processor signals are summarized in [Table 2-9](#).

Table 2-9. Push Button Connections

Push Button Label	Push Button Reference Designator	Processor Pin
PB1	SW8	FLAG1/ $\overline{IRQ1}$
PB2	SW11	FLAG0/ $\overline{IRQ0}$
PB3	SW10	DAI19
PB4	SW9	DAI20

### Board Reset Push Button (SW12)

The RESET push button (SW12) resets all of the ICs on the board. The only exception is the USB interface chip. The chip is not reset when the push button is pressed after the USB cable has been plugged in and communication initialized correctly with the PC. After USB communication has been initialized, the only way to reset the USB is by powering down the board.

## Jumpers

This section describes functionality of the configuration jumpers. The jumper locations are shown in [Figure 2-7](#).

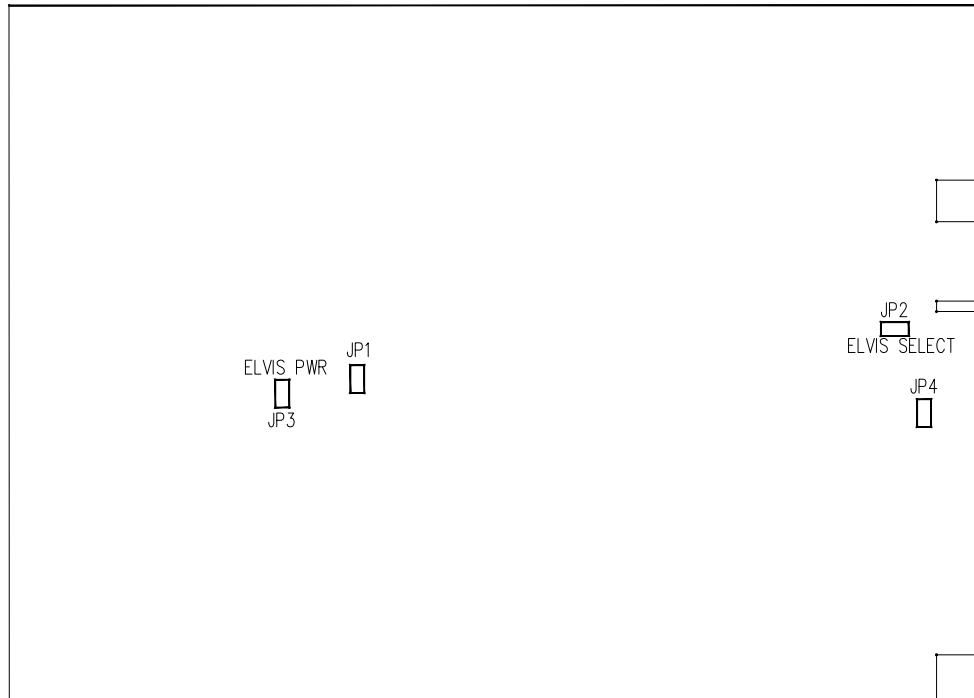

Figure 2-7. Jumper Locations

## Jumpers

### VCO Select Jumper (JP1)

The voltage-controlled oscillator (VCO) select jumper (JP1) configures the frequency selection of the on-board external PLL (U39). When JP1 is installed, the VCO output frequency is multiplied by a factor of 1.0. Conversely, when uninstalled, the VCO output frequency is multiplied by a factor of 0.5 or divided in half. The jumper settings are shown in [Table 2-10](#).

Table 2-10. VCO Select Jumper (JP1)

JP1 Setting	Mode
OFF	VCO output frequency x ½ (default)
ON	VCO output frequency x 1.0

### ELVIS Select Jumper (JP2)

The ELVIS select jumper (JP2) configures the EZ-KIT Lite's connection to an ELVIS station (see [“ELVIS Interface” on page 1-13](#)). When JP2 is installed, connections to the push buttons and LED are re-directed to the ELVIS station instead of the processor. The jumper settings are shown in [Table 2-11](#).

Table 2-11. ELVIS Select Jumper (JP2)

JP2 Setting	Mode
OFF	Not connected to an ELVIS station (default)
ON	Connected to an ELVIS station

## ELVIS Voltage Selection Jumper (JP3)

The ELVIS voltage selection jumper (JP3) is used to select the power source for the EZ-KIT Lite. In a standard mode of operation, the board receives its power from an external power supply. When JP3 is installed, the board is powered from an ELVIS station, and no external power supply is required. The jumper settings are shown in [Table 2-12](#).

Table 2-12. ELVIS Voltage Selection Jumper (JP3)

JP3 Setting	Mode
OFF	Powered from an external power supply (default)
ON	Powered from an ELVIS station

 The external power supply must be disconnected from the board when JP3 is installed to avoid potential damage to the EZ-KIT Lite board and ELVIS unit.

## ELVIS Programmable Flag Jumper (JP4)

The ELVIS programmable flag jumper (JP4) connects the ADSP-21371 processor's DAI4 pin to the ELVIS trigger pin. When JP4 is installed, the pin is connected to the ELVIS TRIG1\_2 pin directly. Conversely, when JP4 is uninstalled, the pin is disconnected and can be used for another non-ELVIS operation. The jumper settings are shown in [Table 2-13](#).

Table 2-13. ELVIS Select Jumper (JP4)

JP4 Setting	Mode
OFF	DAI4 disconnected from the ELVIS TRIG pin (default)
ON	DAI4 connected to the ELVIS TRIG pin

## Connectors

# Connectors

This section describes connector functionality and provides information about mating connectors. The connector locations are shown in [Figure 2-8](#).

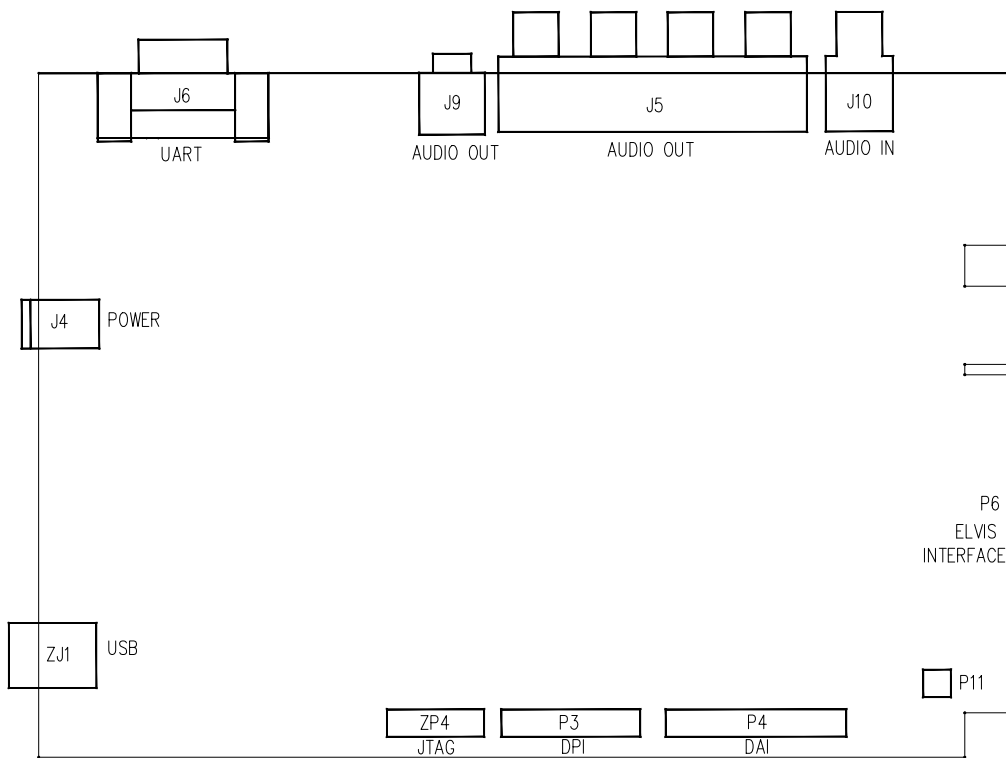

Figure 2-8. Connector Locations



## Expansion Interface Connectors (J1–3)

Three board-to-board connectors (J1–3) provide signals for most peripheral interfaces of the processor. The connectors are located at the bottom of the board. For more information about the expansion interface, see [“Expansion Interface” on page 2-7](#). For the connector availability and pricing, contact Samtec.

Part Description	Manufacturer	Part Number
90-position 0.05” spacing, SMT	SAMTEC	SFC-145-T2-F-D-A
<b>Mating Connectors</b>		
90-position 0.05” spacing (through hole)	SAMTEC	TFM-145-x1 series
90-position 0.05” spacing (surface mount)	SAMTEC	TFM-145-x2 series
90-position 0.05” spacing (low cost)	SAMTEC	TFC-145 series

## Audio In RCA Connector (J10)

Part Description	Manufacturer	Part Number
Two-channel right angle RCA jack	SWITCHCRAFT	PJRS1X2S02
<b>Mating Cable</b>		
Two-channel RCA interconnect cable	MONSTER CABLE	BI100-1M

## Connectors

### Audio Out RCA Connector (J5)

Part Description	Manufacturer	Part Number
Four-channel right angle RCA jack	SWITCHCRAFT	PJRAS4X2U01
<b>Mating Cable</b>		
Two-channel RCA interconnect cable	MONSTER CABLE	BI100-1M

### Headphone Out Jack (J9)

Part Description	Manufacturer	Part Number
3.5 mm stereo jack	A/D ELECTRONICS	ST-323-5

### Power Jack (J4)

The power connector (J4) provides all of the power necessary to operate the EZ-KIT Lite board.

Part Description	Manufacturer	Part Number
2.5 mm power jack	SWITCHCRAFT DIGI-KEY	RAPC712X-ND
<b>Mating Power Supply (shipped with EZ-KIT Lite)</b>		
7V power supply	CUI INC.	DMS070214-P6P-SZ

## ADSP-21371 EZ-KIT Lite Hardware Reference

The power connector supplies DC power to the EZ-KIT Lite board. The power supply specifications are shown in [Table 2-14](#).

Table 2-14. Power Supply Specifications

Terminal	Connection
Center pin	+7 VDC@2.14A
Outer ring	GND

### S/PDIF Coax Connectors (J7 and J8)

Part Description	Manufacturer	Part Number
Coaxial	SWITCHCRAFT	PJ-RAN1X1U01
Mating Cable		
Two-channel RCA interconnect cable	MONSTER CABLE	BI100-1M

### DPI Header (P3)

The DPI connector (P3) provides access to all of the DPI signals in the form of a .1" spacing header. When using the header to access the DPI pins of the processor, ensure that signals, which normally drive the DPI pins, are disabled. For more information, see [“DPI Interface” on page 2-5](#).

Part Description	Manufacturer	Part Number
20-pin IDC header	FCI	68737-420HLF

## Connectors



### DAI Header (P4)

The DAI connector (P4) provides access to all of the DAI signals in the form of a .1" spacing header. When using the header to access the DAI pins of the processor, ensure that signals, which normally drive the DAI pins, are disabled. Refer to [“Codec Setup Switch \(SW3\)” on page 2-10](#) for more information on how to disable signals already being driven from elsewhere on the EZ-KIT Lite.

Part Description	Manufacturer	Part Number
26-pin IDC header	BERG	4102-T08-13LF

### JTAG Header (ZP4)

The JTAG header (ZP4) is the connecting point for a JTAG in-circuit emulator pod. When an emulator connects to the JTAG header, the USB debug interface is disabled.

-  Pin 3 is missing to provide keying. Pin 3 in the mating connector should have a plug.
-  When using an emulator with the EZ-KIT Lite board, follow the connection instructions provided with the emulator.

Part Description	Manufacturer	Part Number
14-pin IDC header	FCI	68737-414HLF

# A ADSP-21371 EZ-KIT LITE BILL OF MATERIALS

The bill of materials corresponds to “[ADSP-21371 EZ-KIT Lite Schematic](#)” on page B-1.

Ref.	Qty.	Description	Reference Designator	Manufacturer	Part Number
1	1	74LVC14A SOIC14	U40	TI	74LVC14AD
2	1	IDT74FCT3244 APY SSOP20	U37	IDT	IDT74FCT3244APYG
3	1	12.288MHZ OSC003	U1	EPSON	SG-8002CA MP
4	1	LT1765 SOIC8	VR1	LINEAR TECH	LT1765ES8#PBF
5	1	MT48LC4M32B 2 TSOP86	U36	DIGI-KEY	557-1196-1-ND
6	1	GTL2002 TSSOP8	U39	PHILIPS	GTL2002DP-T
7	1	SN74LVC1G08 SOT23-5	U18	TI	SN74LVC1G08DBVR
8	1	TLC2932 TSSOP14	U38	TI	TLC2932IPWG4
9	1	SN65LVDS2D SOIC8	U2	NATIONAL SEMI	DS90LV018ATM
10	1	16.384MHZ OSC003	U28	EPSON	SG-8002CA-MPT
11	1	FDC658P SOT23-6	U3	FAIRCHILD	FDC658P

Ref.	Qty.	Description	Reference Designator	Manufacturer	Part Number
12	1	SI7601DN ICS010	U45	VISHAY	SI7601DN
13	1	21371 M25P20 U29	U29	ST	M25P20-VMN6TP
14	1	21371 AM29LV081B U35	U35	AMD	AM29LV081-70ED
15	1	ADM708SARZ SOIC8	U23	ANALOG DEVICES	ADM708SARZ
16	1	AD8532ARZ SOIC8	U19	ANALOG DEVICES	AD8532ARZ
17	2	ADP3336ARMZ MSOP8	VR3-4	ANALOG DEVICES	ADP3336ARMZ-REEL7
18	1	ADM3202ARNZ SOIC16	U32	ANALOG DEVICES	ADM3202ARNZ
19	8	AD8606ARZ SOIC8	U8-15	ANALOG DEVICES	AD8606ARZ
20	1	AD1835AASZ MQFP52	U31	ANALOG DEVICES	AD1835AASZ
21	2	AD623ARMZ USOIC8	U5-6	ANALOG DEVICES	AD623ARMZ
22	2	AD820ARZ SOIC8	U33-34	ANALOG DEVICES	AD820ARZ
23	1	ADSP-21371KS WZ MQFP208	U44	ANALOG DEVICES	ADSP-21371KSWZ-2B
24	2	ADG774ABRQZ QSOP16	U24-25	ANALOG DEVICES	ADG774ABRQZ
25	2	ADP1864AUJZ SOT23-6	VR5-6	ANALOG DEVICES	ADP1864AUJZ-R7
26	5	RUBBER FOOT	M1-5	MOUSER	517-SJ-5018BK

## ADSP-21371 EZ-KIT Lite Bill of Materials

Ref.	Qty.	Description	Reference Designator	Manufacturer	Part Number
27	1	PWR 2.5MM_JACK CON005	J4	SWITCH- CRAFT	RAPC712X
28	1	RCA 4X2 CON011	J5	SWITCH- CRAFT	PJRAS4X2U01X
29	1	RCA 1X1 CON012	J8	SWITCH- CRAFT	PJLAN1X1U01X
30	5	MOMENTARY SWT013	SW8-12	PANASONIC	EVQ-PAD04M
31	3	.05 45X2 CON019	J1-3	SAMTEC	SFC-145-T2-F-D-A
32	2	DIP8 SWT016	SW1,SW14	C&K	TDA08H0SB1
33	1	DIP6 SWT017	SW13	CTS	218-6LPST
34	7	DIP4 SWT018	SW2-7,SW15	ITT	TDA04HOSB1
35	1	DB9 9PIN DB9F	J6	TYCO	5747844-4
36	1	RCA RCA_1X2 CON031	J10	SWITCH- CRAFT	PJRAS1X2S02X
37	4	IDC 2X1 IDC2X1	JP1-4	FCI	90726-402HLF
38	1	IDC 10X2 IDC10X2	P3	BURG-FCI	54102-T08-10LF
39	1	2.5A RESE- TABLE FUS001	F1	RAYCHEM	SMD250F-2
40	1	IDC 2X2 IDC2X2	P11	FCI	68737-404HLF
41	1	3.5MM STEREO_JACK CON001	J9	DIGI-KEY	CP1-3525NG-ND
42	1	IDC 13X2 IDC13X2	P4	BERG	54102-T08-13LF

Ref.	Qty.	Description	Reference Designator	Manufacturer	Part Number
43	8	YELLOW LED001	LED1-8	PANASONIC	LN1461C
44	10	0.22UF 25V 10% 0805	C77,C91-92,C118-119, C152-154,C185-186	AVX	08053C224KAT2A
45	1	0.1UF 50V 10% 0805	C216	AVX	08055C104KAT
46	4	600 100MHZ 200MA 0603	FER2-5	DIGI-KEY	490-1014-2-ND
47	2	2A S2A DO-214AA	D3-4	VISHAY	S2A-E3
48	4	1UF 16V 10% 0805	C204,C207-209	KEMET	C0805C105K4RAC TU
49	1	10UF 25V +80-20% 1210	C215	DIGI-KEY	587-1393-2-ND
50	2	68UF 25V 20% CAP003	CT1-2	PANASONIC	EEE-FC1E680P
51	1	2A SL22 DO-214AA	D1	DIGI-KEY	SL22-E3/1GI-ND
52	2	0 1/10W 5% 0805	R195-196	VISHAY	CRCW08050000Z0EA
53	1	190 100MHZ 5A FER002	FER7	MURATA	DLW5BSN191SQ2
54	20	10UF 6.3V 10% 0805	C23-24,C57-58,C84-85, C111-114,C144-147, C151,C162-163,C176, C205-206	AVX	08056D106KAT2A
55	3	6.04K 1/10W 1% 0805	R28-30	DIGI-KEY	311-6.04KCRCT-ND
56	1	4.7UF 6.3V 10% 0805	C221	AVX	08056D475KAT2A
57	6	0.1UF 10V 10% 0402	C75-76,C168-171	AVX	0402ZD104KAT2A



## ADSP-21371 EZ-KIT Lite Bill of Materials

Ref.	Qty.	Description	Reference Designator	Manufacturer	Part Number
58	82	0.01UF 16V 10% 0402	C4,C6-22,C25-30,C32-56,C59-63,C68-70,C78-83,C86-87,C90,C93,C100,C173,C177-178,C183,C188,C190-196,C201-202	AVX	0402YC103KAT2A
59	22	10K 1/16W 5% 0402	R5,R19-23,R25-26,R32-34,R132,R152-156,R161-162,R173-175	VISHAY	CRCW040210K0FKED
60	2	4.7K 1/16W 5% 0402	R1,R180	VISHAY	CRCW04024K70JNED
61	13	0 1/16W 5% 0402	R2-4,R7-8,R11-15,R107,R121,R138	PANASONIC	ERJ-2GE0R00X
62	2	22 1/16W 5% 0402	R124,R133	PANASONIC	ERJ-2GEJ220X
63	2	33 1/16W 5% 0402	R6,R27	VISHAY	CRCW040233R0JNEA
64	1	1.5UH 20% IND003	L2	COIL CRAFT	DO1608C-152MLC
65	1	100MA CMD5H-3 SOD-323	D2	GENERAL- SEMI	CMD5H-3-E3
66	1	0.18UF 25V 10% 0805	C218	AVX	08053C184KAT2A
67	1	100UF 10V 10% C	CT3	AVX	TPSC107K010R0075
68	2	1000PF 50V 5% 0402	C213-214	AVX	04025C102JAT2A
69	2	64.9K 1/10W 1% 0805	R190,R194	VISHAY	CRCW080564K9FKEA
70	2	210.0K 1/4W 1% 0805	R191,R193	VISHAY	CRCW0805210KFKEA

Ref.	Qty.	Description	Reference Designator	Manufacturer	Part Number
71	2	0.1UF 16V 10% 0603	C187,C189	AVX	0603YC104KAT2A
72	1	1UF 16V 10% 0603	C179	PANASONIC	ECJ-1VB1C105K
73	2	4.7UF 25V 20% 0805	C217,C220	AVX	0805ZD475KAT2A
74	2	68PF 50V 5% 0603	C2,C224	AVX	06035A680JAT2A
75	8	330PF 50V 5% 0603	C95,C101,C107,C116, C123,C129,C134,C142	AVX	06035A331JAT2A
76	2	470PF 50V 5% 0603	C5,C223	AVX	06033A471JAT2A
77	10	330 1/10W 5% 0603	R163-164,R168-172, R176-178	VISHAY	CRCW0603330RJNEA
78	7	0 1/10W 5% 0603	R18,R31,R126,R184, R186,R192,R202	PHYCOMP	232270296001L
79	4	10 1/10W 5% 0603	R157-160	VISHAY	CRCW060310R0JNEA
80	3	10.0K 1/16W 1% 0603	R125,R142,R148	DALE	CRCW060310K0FKEA
81	1	75.0K 1/16W 1% 0603	R131	VISHAY	CRCW060375K0FKEA
82	1	200.0K 1/16W 1% 0603	R134	VISHAY	CRCW0603200KFKEA
83	1	25.5K 1/16W 1% 0603	R150	DIGI-KEY	311-25.5KHRTR-ND
84	1	51.1K 1/16W 1% 0603	R197	VISHAY	CRCW060351K1FKEA
85	4	237.0 1/10W 1% 0603	R108-109,R122-123	DIGI-KEY	311-237HRTR-ND
86	2	750.0K 1/10W 1% 0603	R110,R116	DIGI-KEY	311-750KHRTR-ND

## ADSP-21371 EZ-KIT Lite Bill of Materials

Ref.	Qty.	Description	Reference Designator	Manufacturer	Part Number
87	11	11.0K 1/10W 1% 0603	R39-40,R50,R58,R73, R81,R86,R97,R102, R115,R144	DIGI-KEY	311-11.0KHRTR-ND
88	20	5.49K 1/10W 1% 0603	R37,R41-42,R48,R51, R56,R59,R67,R72,R75, R80,R83-84,R87,R96, R99,R103-104, R113-114	DIGI-KEY	311-5.49KHRTR-ND
89	9	3.32K 1/10W 1% 0603	R36,R43,R49,R57,R74, R82,R85,R94,R130	DIGI-KEY	311-3.32KHRTR-ND
90	8	1.65K 1/10W 1% 0603	R44,R52,R60,R64,R71, R79,R88,R95	DIGI-KEY	311-1.65KHRTR-ND
91	10	49.9K 1/10W 1% 0603	R46,R55,R63,R66,R68, R76,R91-92,R119-120	DIGI-KEY	311-49.9KHRTR-ND
92	8	604.0 1/10W 1% 0603	R45,R54,R62,R65,R69, R77,R90,R93	NIC COM- PONENTS	NRC06F6040TRF
93	2	90.9K 1/10W 1% 0603	R146,R151	DIGI-KEY	311-90.9KHRTR-ND
94	2	0.1 1/10W 1% 0603	R143,R149	PANASONIC	ERJ-3RSFR10V
95	3	10.0K 1/10W 1% 0603	R145,R147,R182	DIGI-KEY	311-10.0KHRTR-ND
96	4	5.76K 1/10W 1% 0603	R111-112,R117-118	DIGI-KEY	311-5.76KHRTR-ND
97	12	100PF 50V 5% 0603	C94,C99,C105,C117, C125,C131-132,C140, C155,C161,C166-167	AVX	06035A101JAT2A
98	4	1000PF 50V 5% 0603	C156-157,C164-165	PANASONIC	ECJ-1VC1H102J
99	1	47.5K 1/10W 1% 0603	R183	DIGI-KEY	311-47.5KHRTR-ND
100	8	220PF 50V 5% 0603	C89,C97,C103,C109, C121,C127,C136,C139	PANASONIC	ECJ-1VC1H221J

Ref.	Qty.	Description	Reference Designator	Manufacturer	Part Number
101	12	680PF 50V 5% 0603	C96,C102,C108,C115, C122,C128,C135,C141, C148-149,C158,C160	PANASONIC	ECJ-1VC1H681J
102	9	2200PF 50V 5% 0603	C88,C98,C104,C110, C120,C126,C137-138, C219	PANASONIC	ECJ-1VB1H222K
103	8	2.74K 1/10W 1% 0603	R38,R47,R53,R61,R70, R78,R89,R98	DIGI-KEY	311-2.74KHRTR-ND
104	1	75.0 1/10W 1% 0603	R141	DALE	CRCW060375R0FKEA
105	4	1UF 6.3V 20% 0402	C197-200	PANASONIC	ECJ-0EB0J105M
106	4	100 1/16W 5% 0402	R165-167,R179	DIGI-KEY	311-100JRTR-ND
107	1	0.027UF 25V 5% 0603	C181	AVX	06033C273JAT2A
108	2	0.27UF 16V 20% 0603	C180,C182	AVX	0603YG274ZAT2A
109	2	2.05K 1/16W 1% 0402	R100-101	VISHAY	CRCW04022K05FKED
110	1	15.0K 1/16W 1% 0603	R140	DIGI-KEY	311-15.0KHRTR-ND
111	1	232.0 1/16W 1% 0603	R129	DIGI-KEY	311-232HRTR-ND
112	2	301.0 1/16W 1% 0603	R105-106	DIGI-KEY	311-301HRTR-ND
113	2	24.9K 1/10W 1% 0603	R17,R198	DIGI-KEY	311-24.9KHTR-ND
114	1	47UF 6.3V 10% B	CT5	NIC COM- PONENTS	NTC-T476K6.3TRBF
115	1	511.0 1/16W 1% 0402	R135	DIGI-KEY	311-511LCT-ND

## ADSP-21371 EZ-KIT Lite Bill of Materials

Ref.	Qty.	Description	Reference Designator	Manufacturer	Part Number
116	1	0.05 1/2W 1% 1206	R16	SEI	CSF 1/2 0.05 1%R
117	2	10UF 16V 10% 1210	C3,C225	AVX	1210YD106KAT2A
118	1	GREEN LED001	LED9	PANASONIC	LN1361CTR
119	1	RED LED001	LED10	PANASONIC	LN1261CTR
120	1	255.0K 1/10W 1% 0603	R35	VISHAY	CRCW06032553FK
121	2	80.6K 1/10W 1% 0603	R181,R199	DIGI-KEY	311-80.6KHRCT-ND
122	1	6.8UH 25% IND009	L3	DIGI-KEY	308-1328-1-ND
123	1	4A SSB43L DO-214AA	D5	VISHAY	SSB43L
124	4	5A MBRS540T3G SMC	D11-14	ON SEMI	MBRS540T3G
125	1	2.5UH 30% IND013	L4	COILCRAFT	MSS1038-252NLB
126	1	470UF 2.5V 20% D2E	CT7	SANYO	2R5TPE470MF
127	3	30A GSOT05 SOT23-3	D7-9	VISHAY	GSOT05-GS08
128	1	30A GSOT03 SOT23-3	D10	VISHAY	GSOT03-GS08
129	1	7A VESD01-02V- GS08 SOD-52	D6	VISHAY	VESD01-02V-GS08
130	2	0.03 1/2W 1% 1206	R200-201	SEI	CSF 1/2 0.03 1%R



2

# ADSP

3

4

A

B

2

3

4

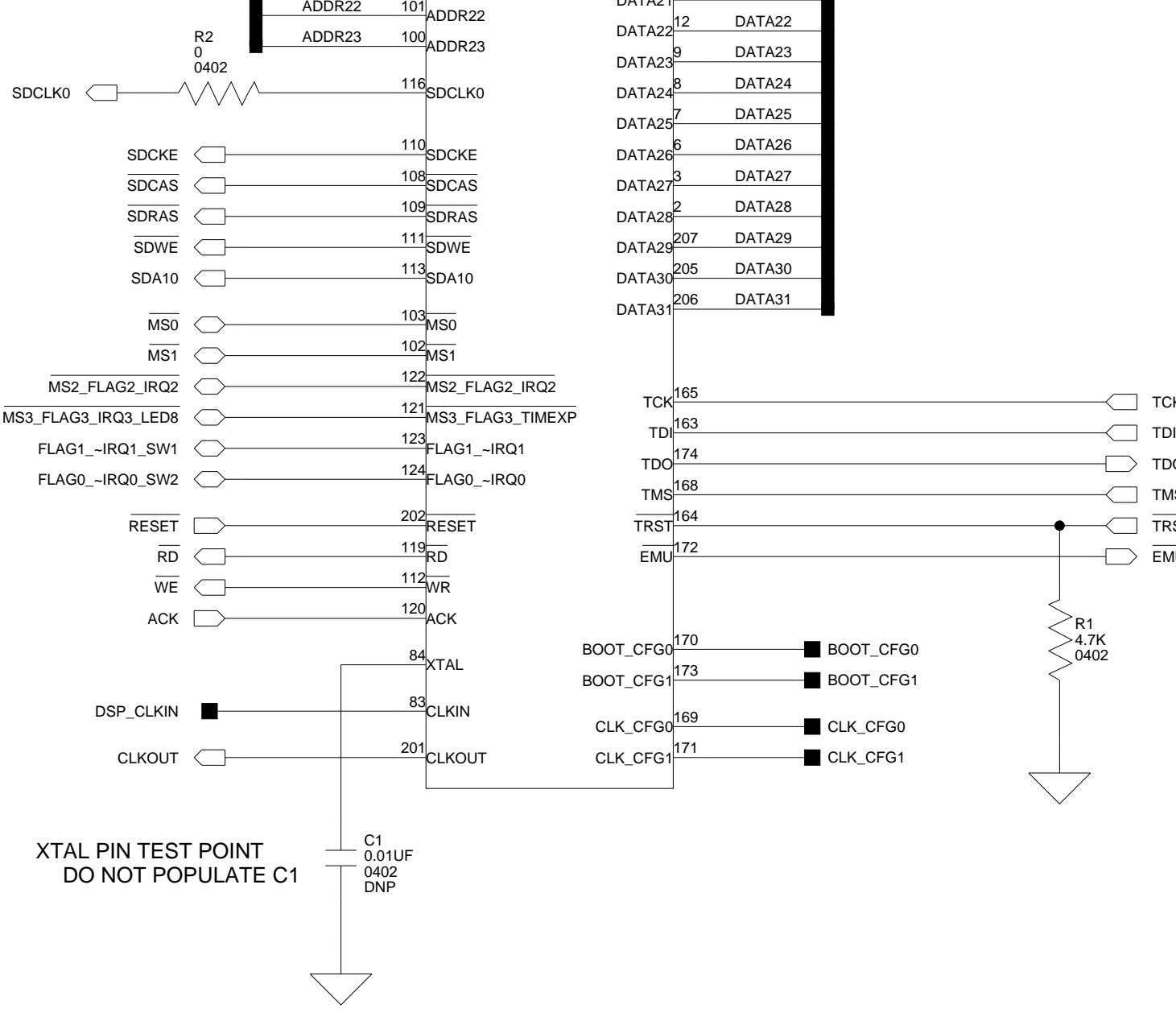

XTAL PIN TEST POINT  
DO NOT POPULATE C1

### DSP OSC

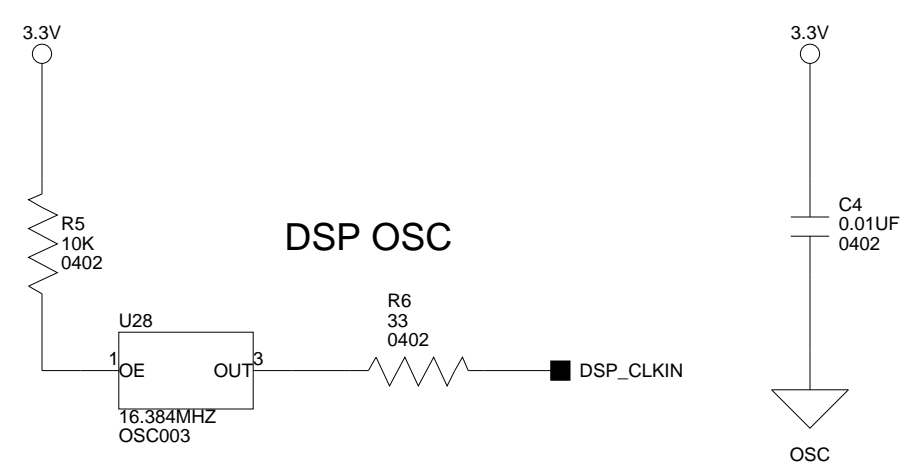

A

B



2

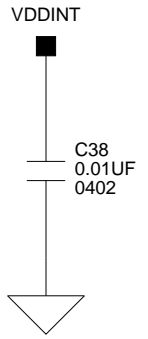

3

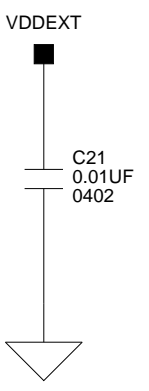

4

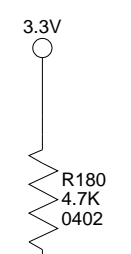
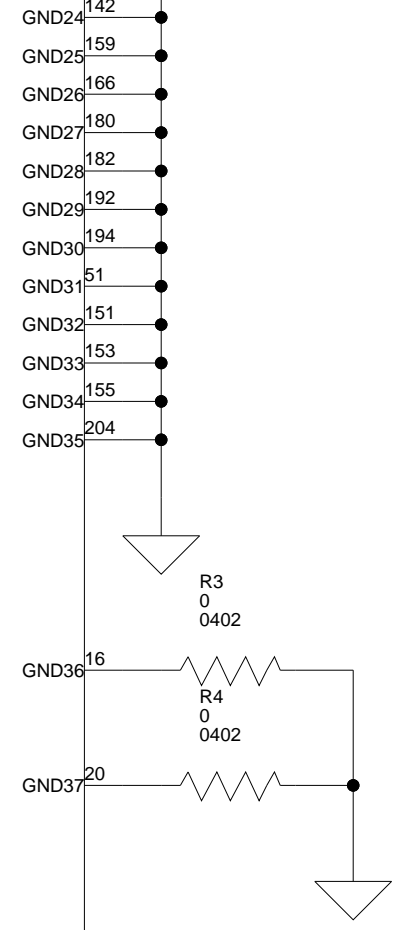
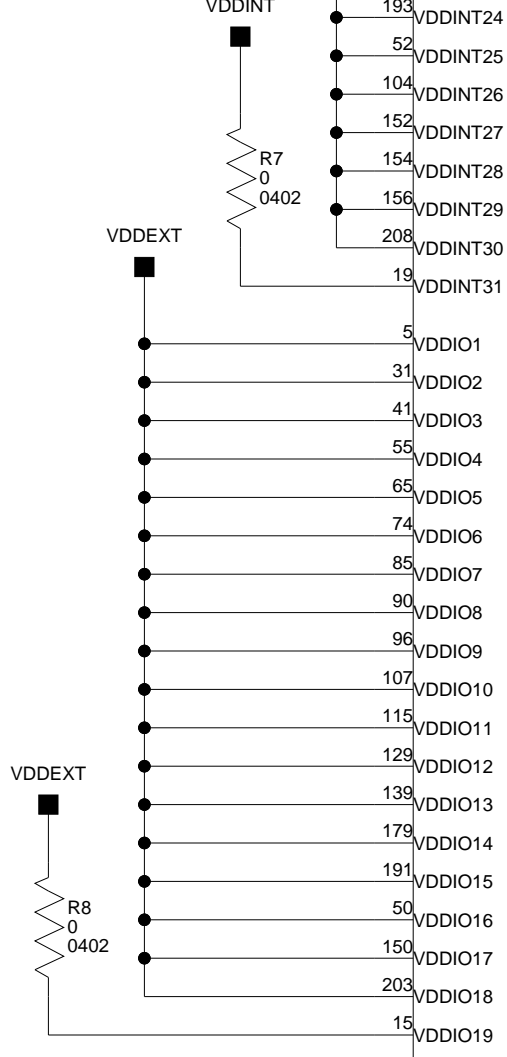

A

B

2

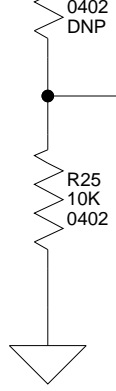

SDRAS

DQM\_21371

3.3V

DQM signals are either tied to GND or driven by processor's FLAG pin. This is SDRAM device specific and the requirement is specified in SDRAM datasheets

3

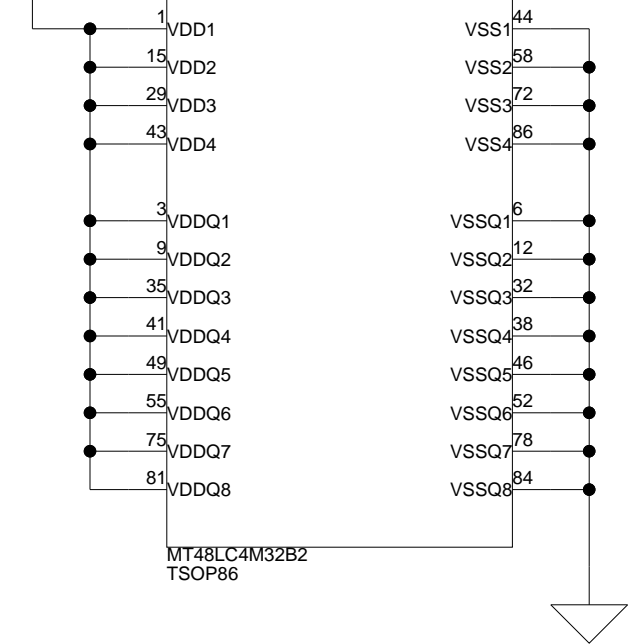

MT48LC4M32B2  
TSOP86

4

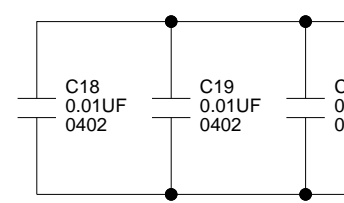
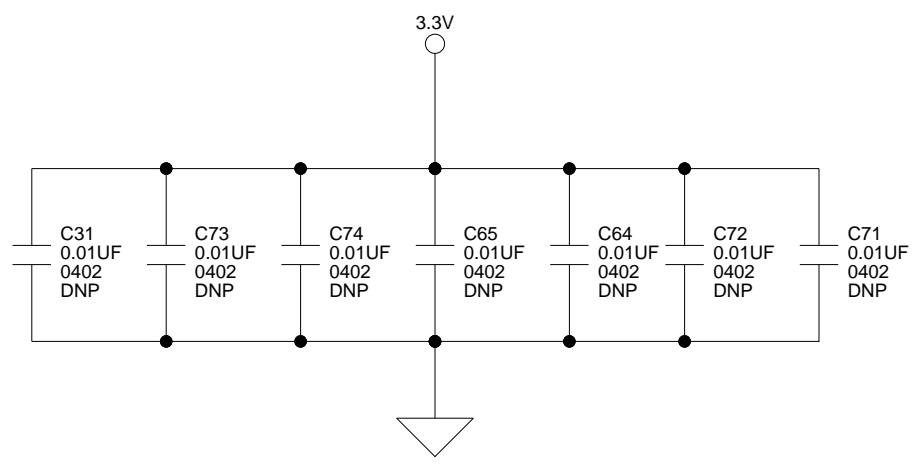

A

B

2

3

4

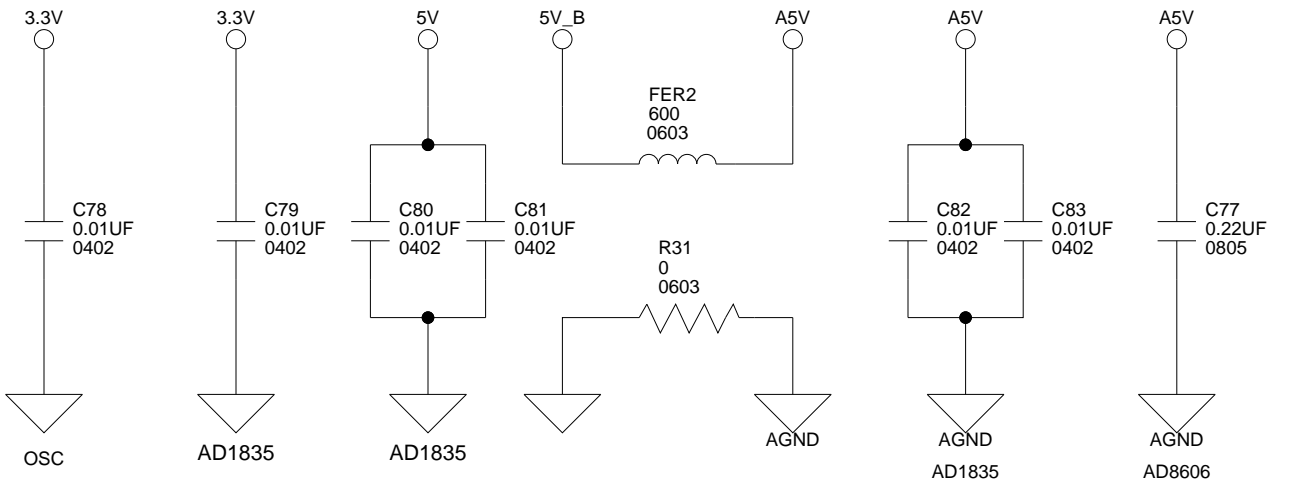
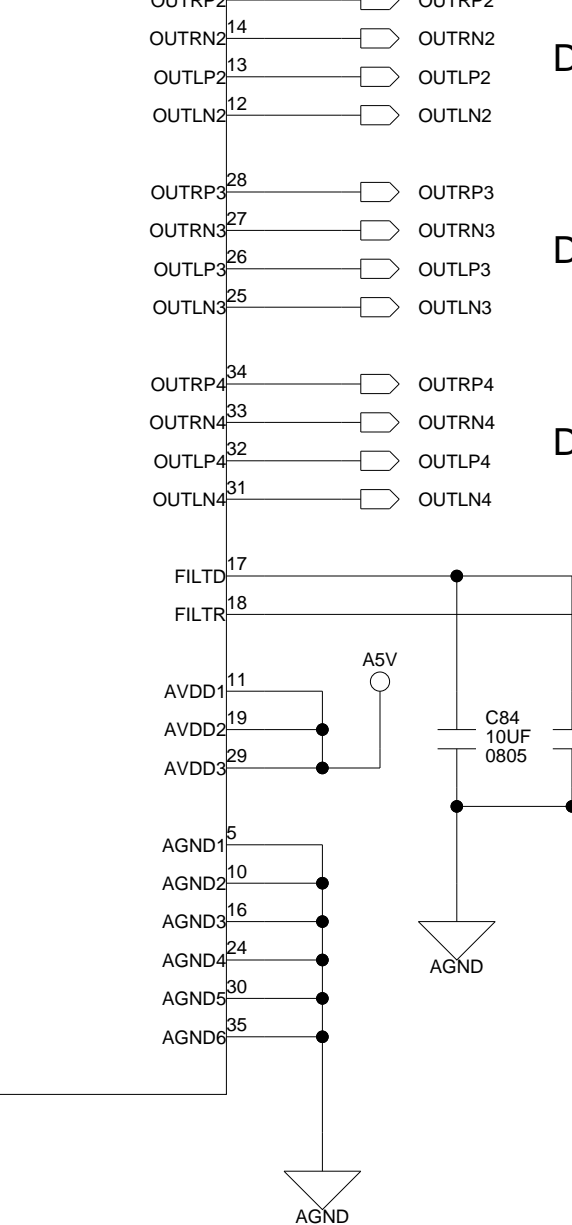
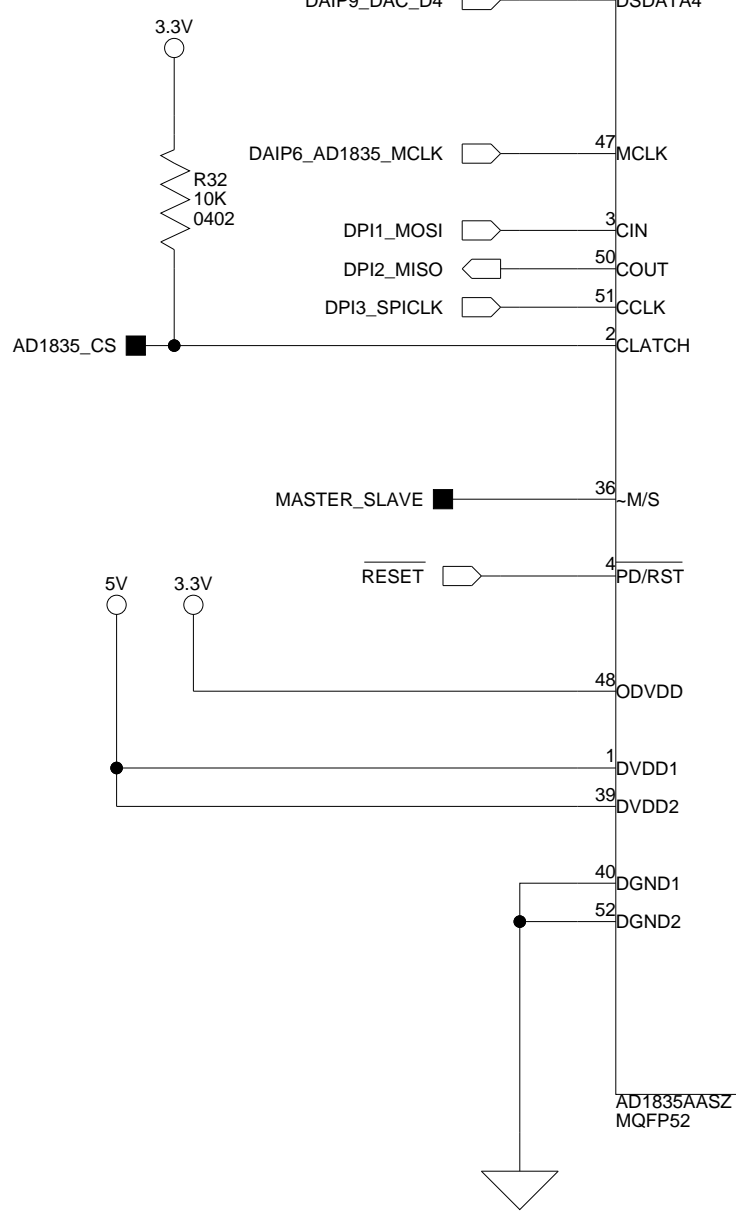

A

B

2

3

4

### DAC1 RIGHT

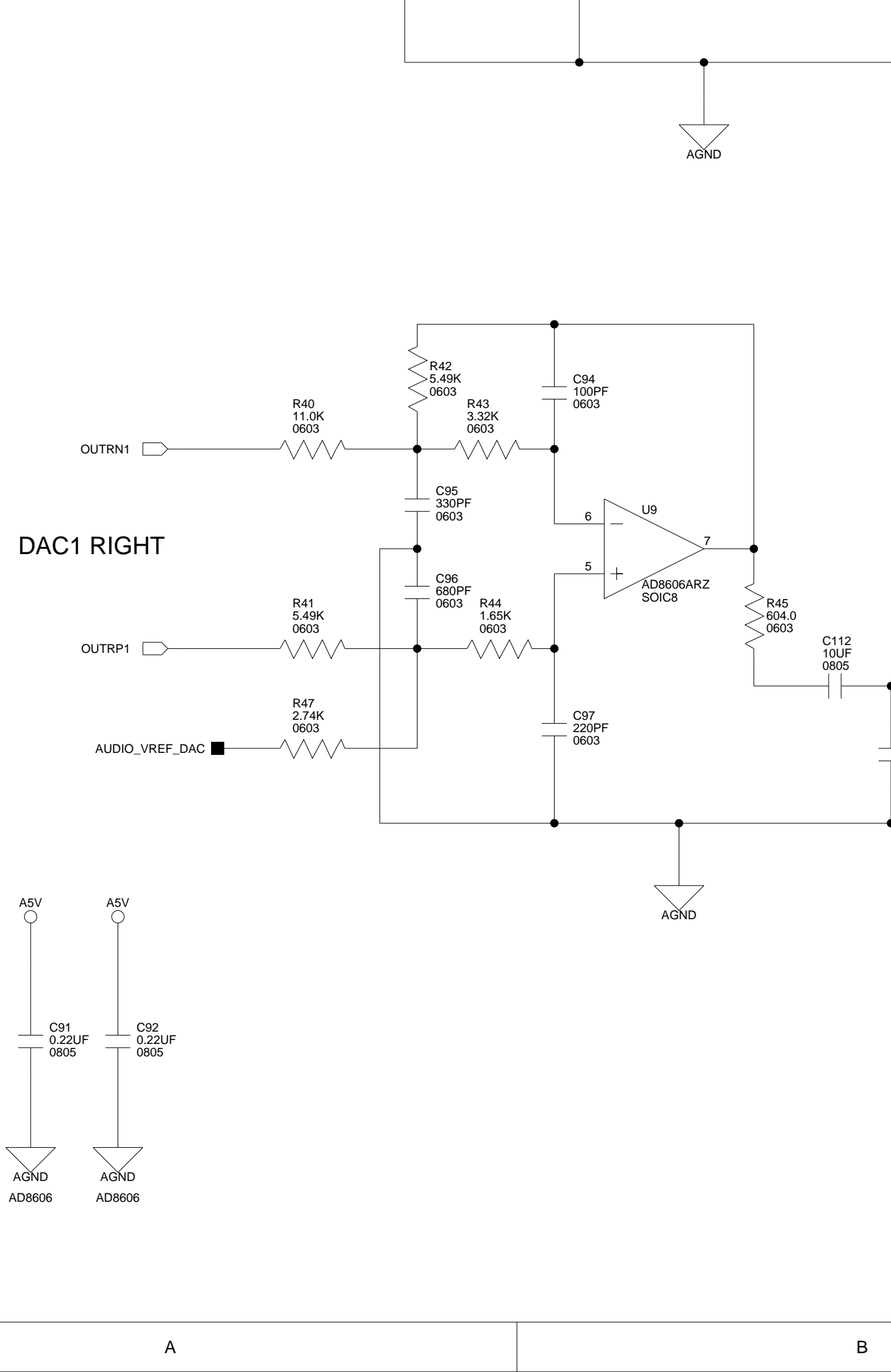

A

B

2

3

4

### DAC3 RIGHT

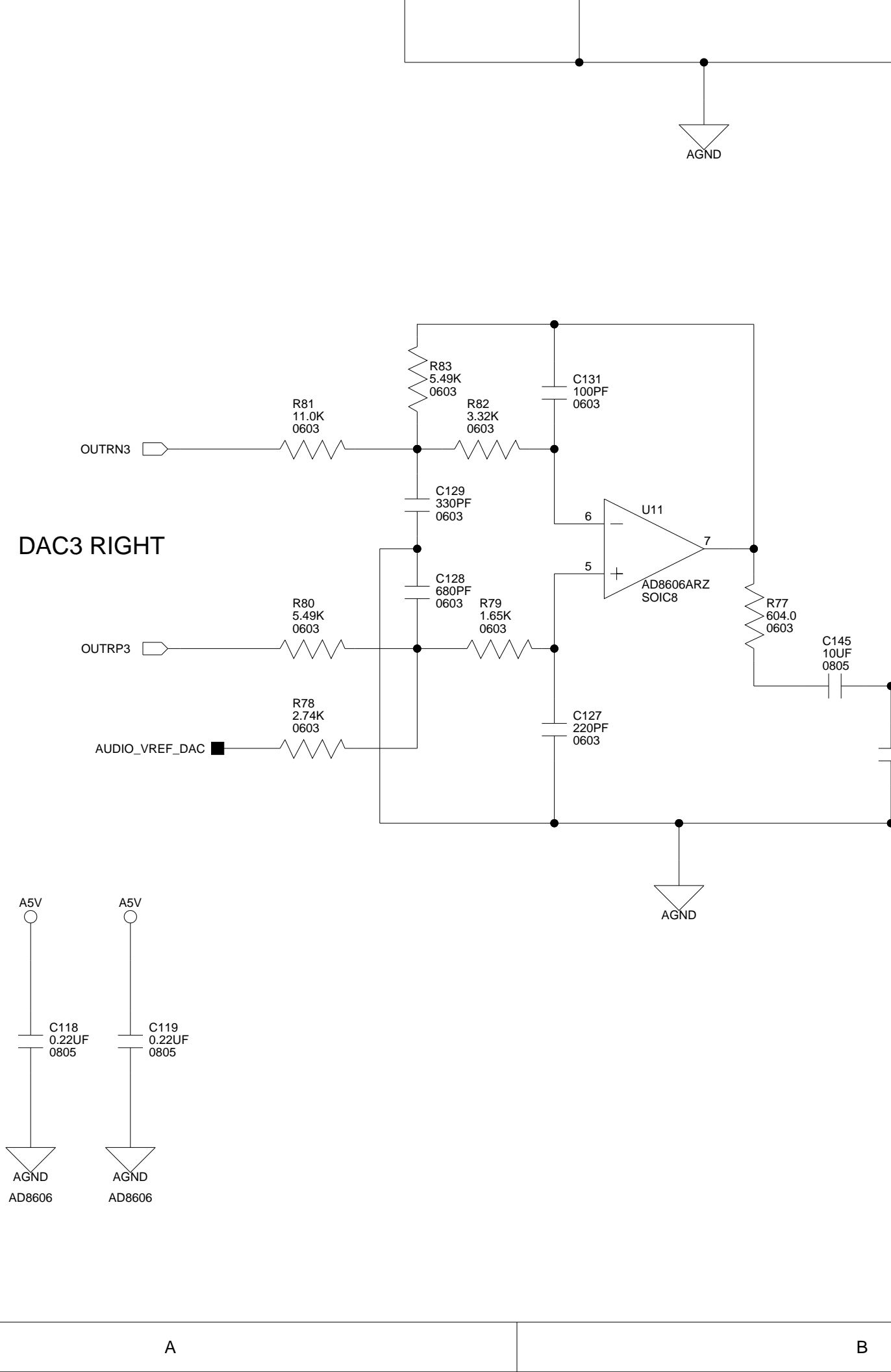

A

B

2

3

4

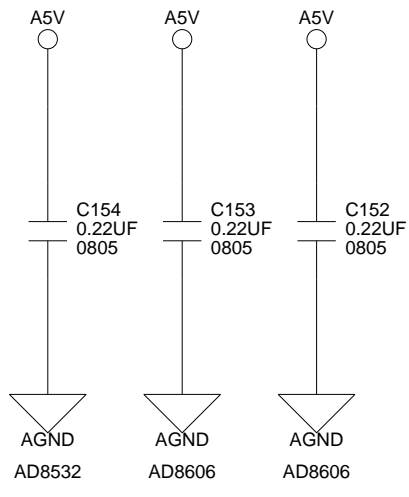
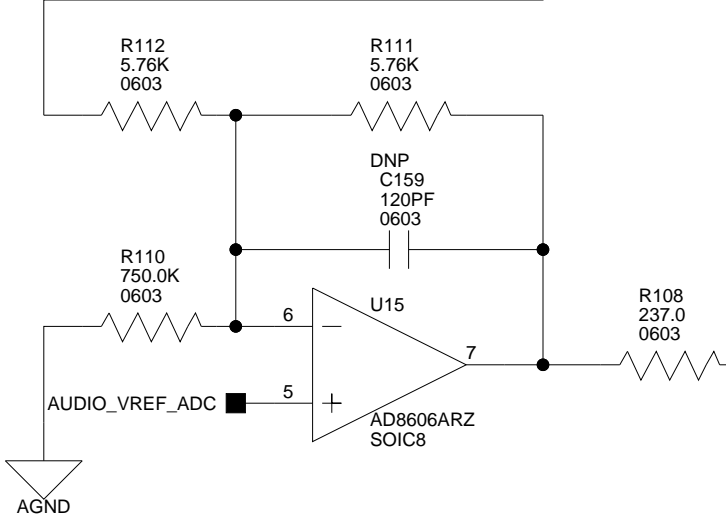
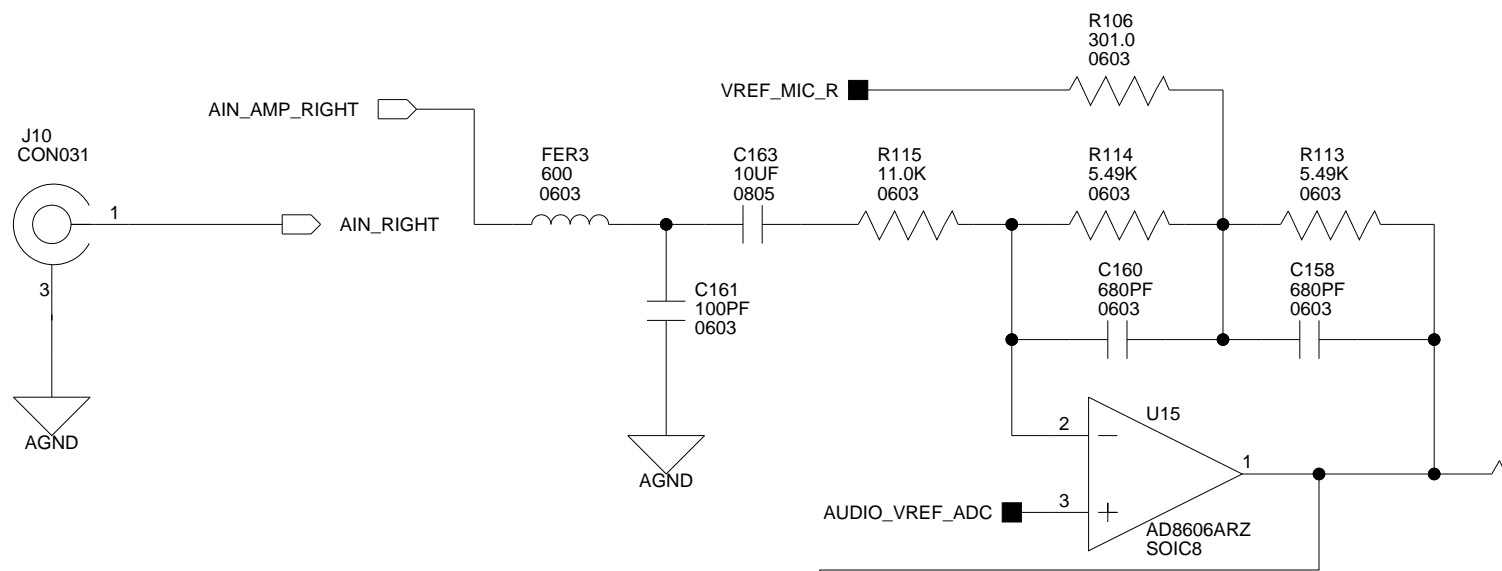

A

B

2

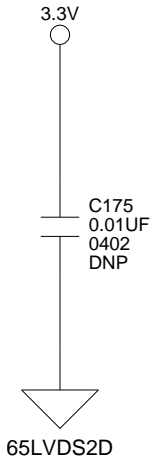

DAIP2\_PLLMCLK\_OUT  
DAIP3\_PLLMCLK\_IN

3

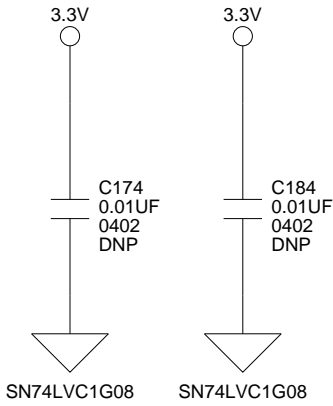
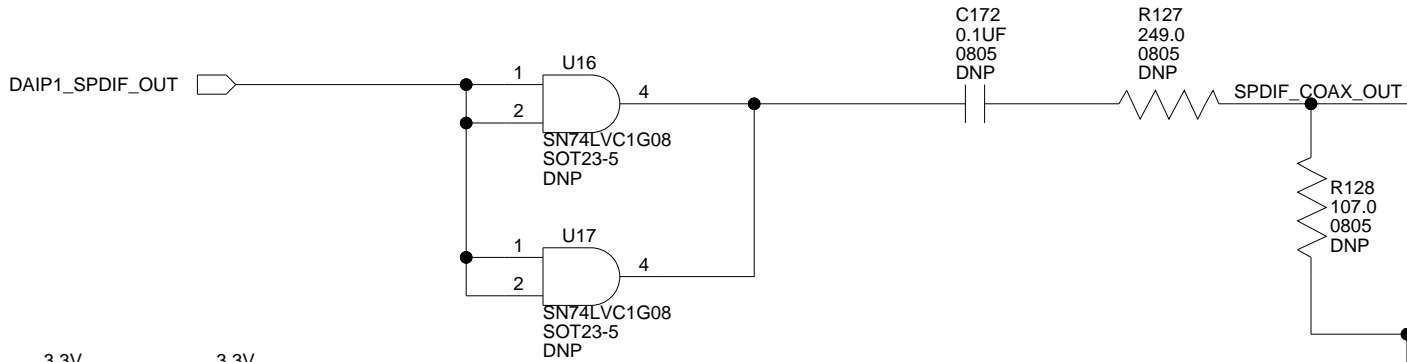

Loopback Test Switch  
(Default= All OFF)  
For Test Purposes Only

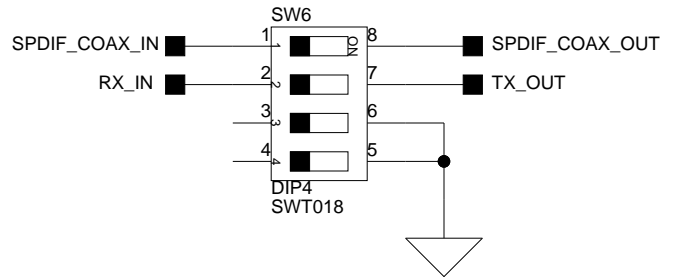

4

A

B

# DSP CORE CURRENT

2

3

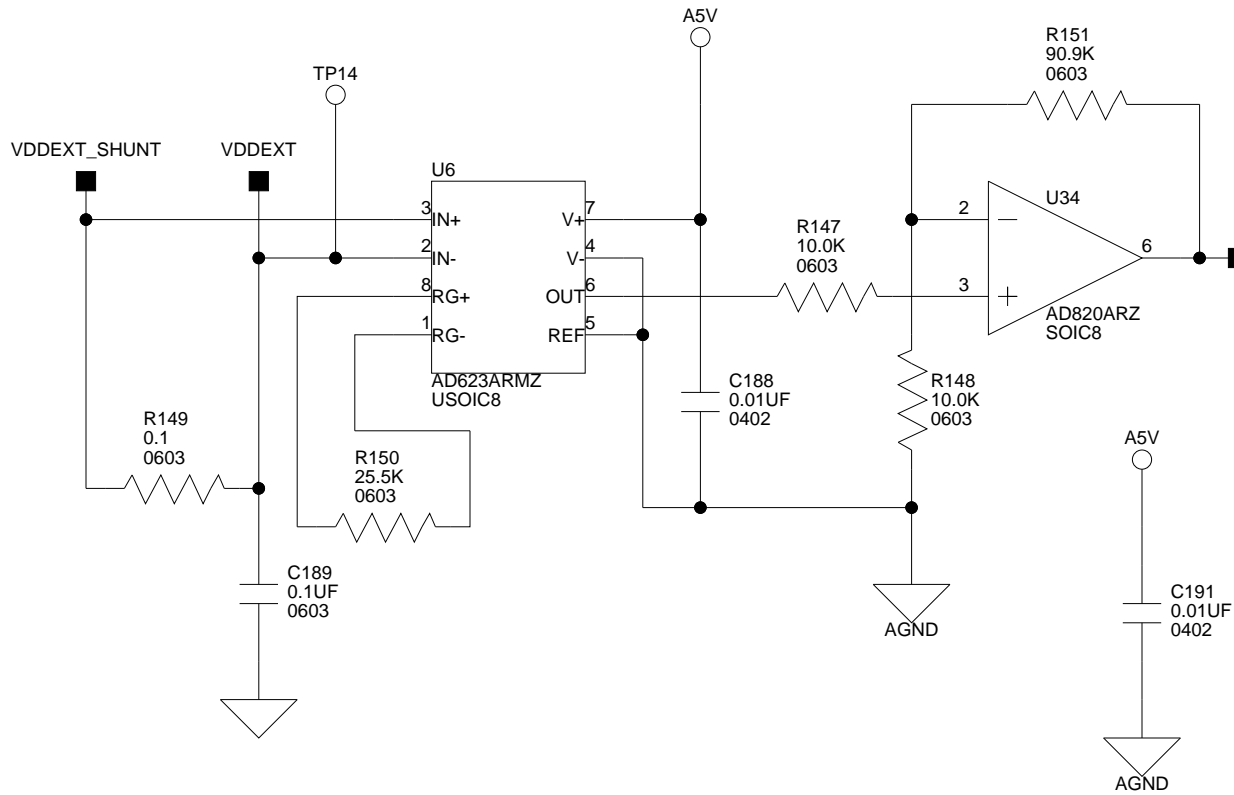

# DSP IO CURRENT

4

A

B



2

3

4

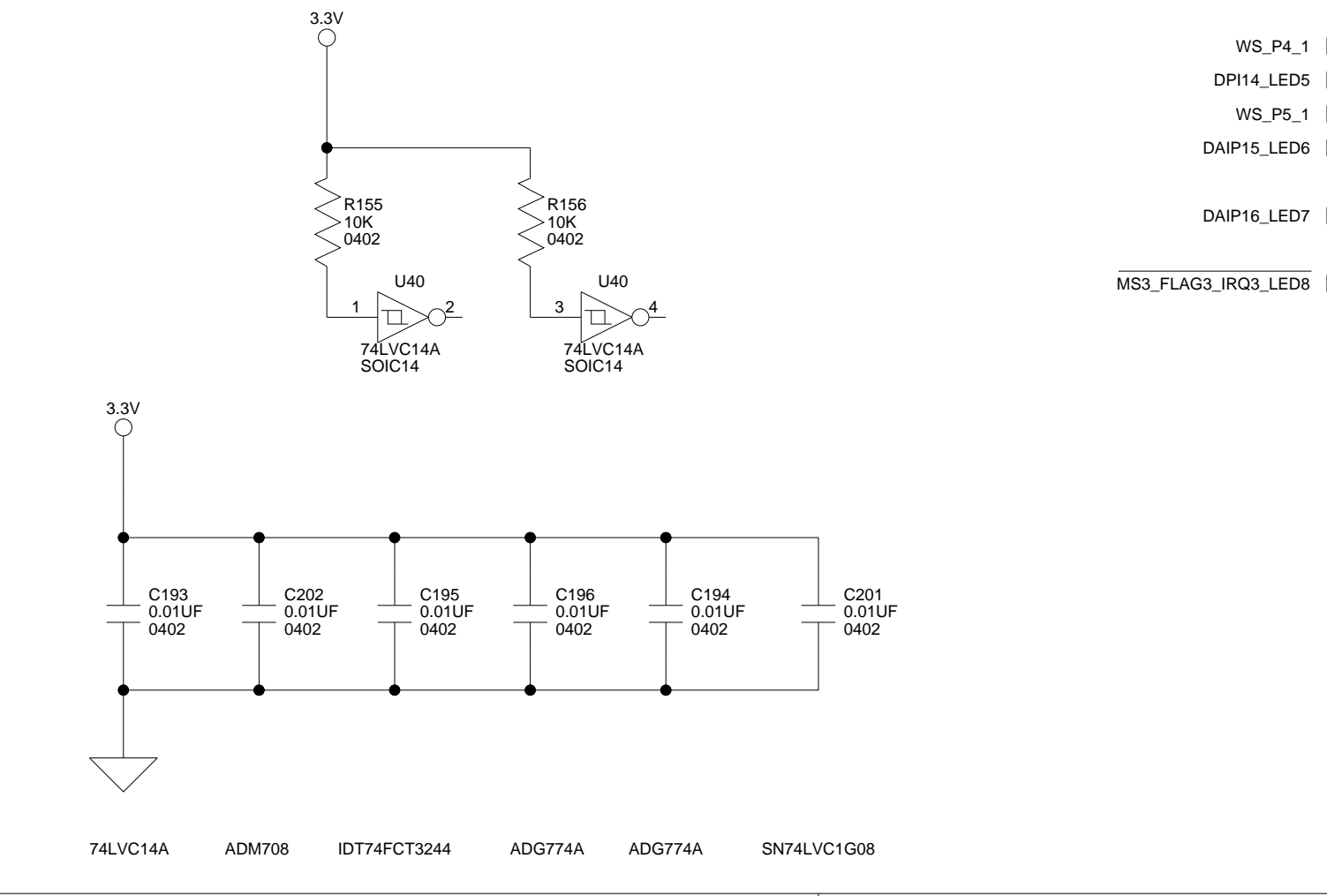
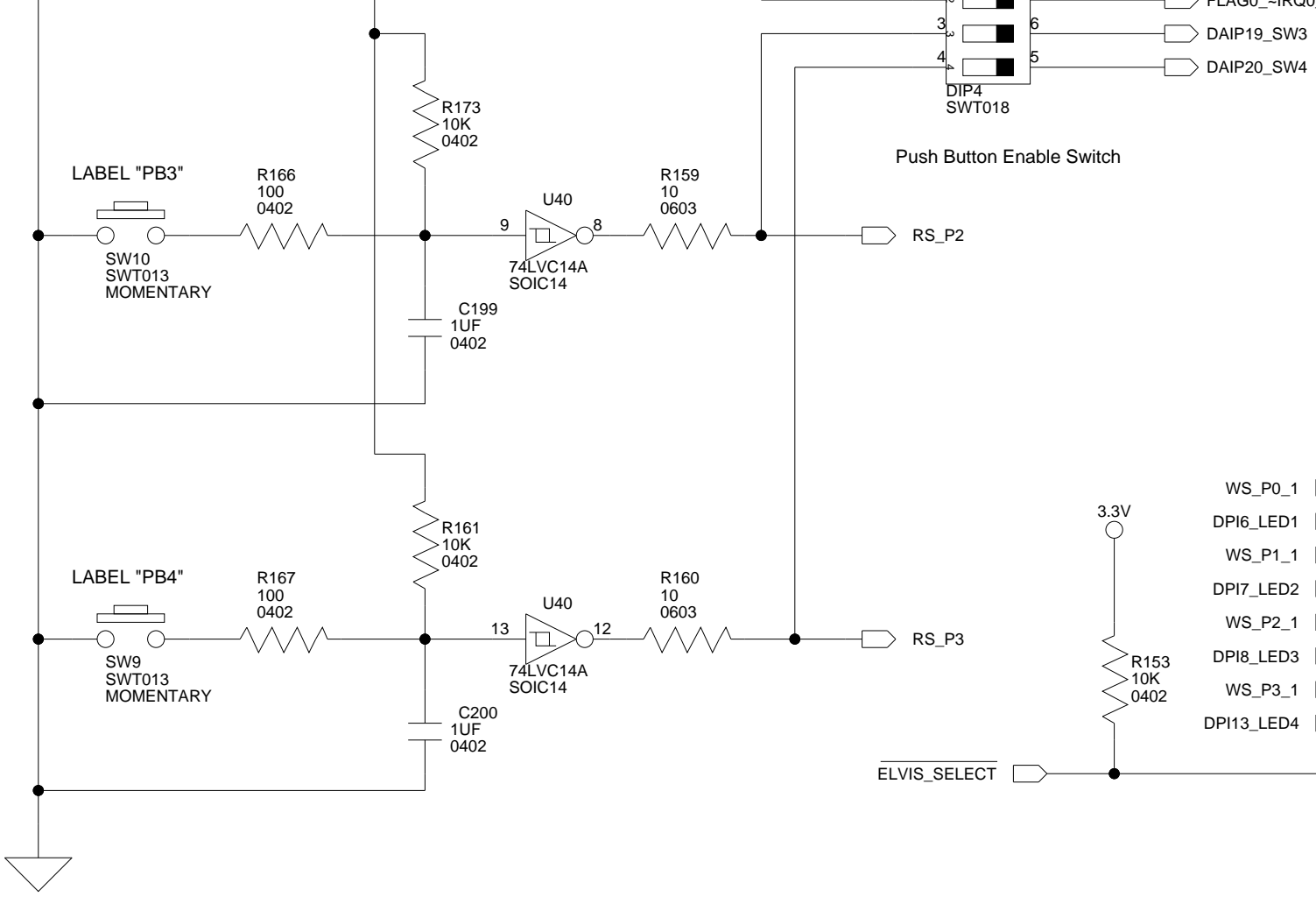

74LVC14A    ADM708    IDT74FCT3244    ADG774A    ADG774A    SN74LVC1G08

A

B

FLAG0\_IRQ3  
DAIP19\_SW3  
DAIP20\_SW4  
WS\_P0\_1  
DPI6\_LED1  
WS\_P1\_1  
DPI7\_LED2  
WS\_P2\_1  
DPI8\_LED3  
WS\_P3\_1  
DPI13\_LED4  
WS\_P4\_1  
DPI14\_LED5  
WS\_P5\_1  
DAIP15\_LED6  
DAIP16\_LED7  
MS3\_FLAG3\_IRQ3\_LED8

Push Button Enable Switch

ELVIS\_SELECT

3.3V

LABEL "PB3"

LABEL "PB4"

SW10  
SWT013  
MOMENTARY

SW9  
SWT013  
MOMENTARY

DIP4  
SWT018

RS\_P2

RS\_P3

R166  
100  
0402

R167  
100  
0402

R173  
10K  
0402

R161  
10K  
0402

R155  
10K  
0402

U40  
74LVC14A  
SOIC14

U40  
74LVC14A  
SOIC14

U40  
74LVC14A  
SOIC14

U40  
74LVC14A  
SOIC14

C193  
0.01UF  
0402

C202  
0.01UF  
0402

C195  
0.01UF  
0402

C196  
0.01UF  
0402

C194  
0.01UF  
0402

C201  
0.01UF  
0402

C199  
1UF  
0402

C200  
1UF  
0402

R159  
10  
0603

R160  
10  
0603

R153  
10K  
0402

2

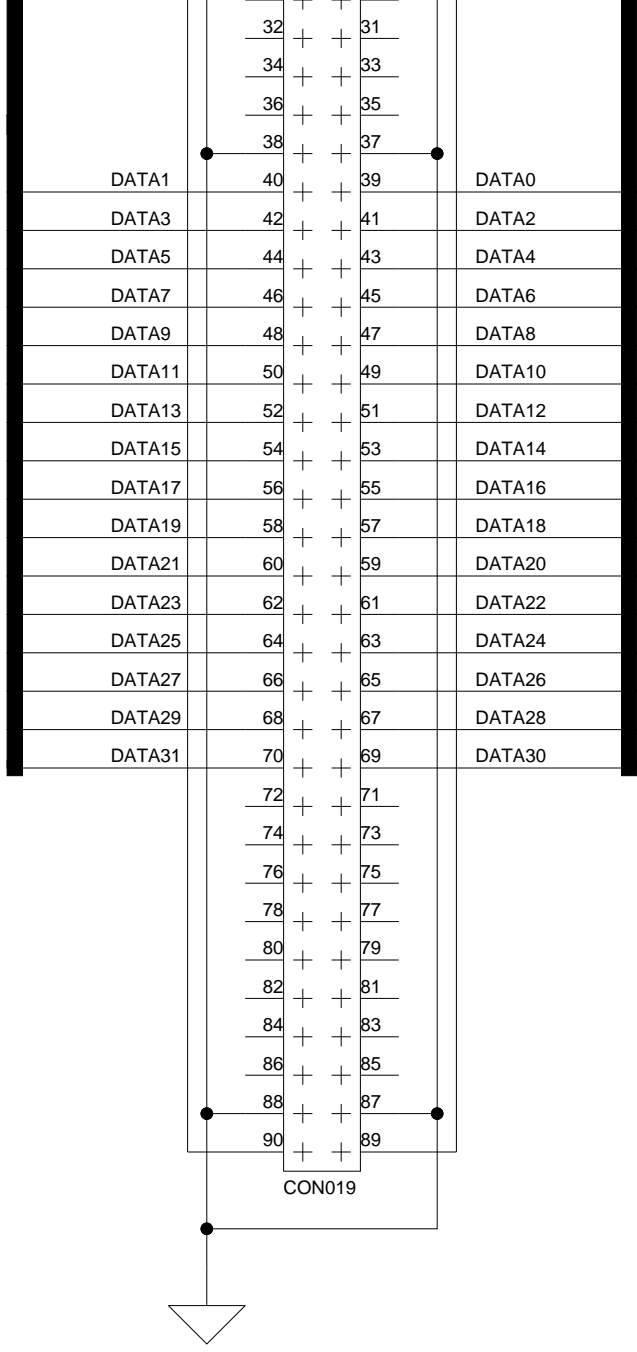

3

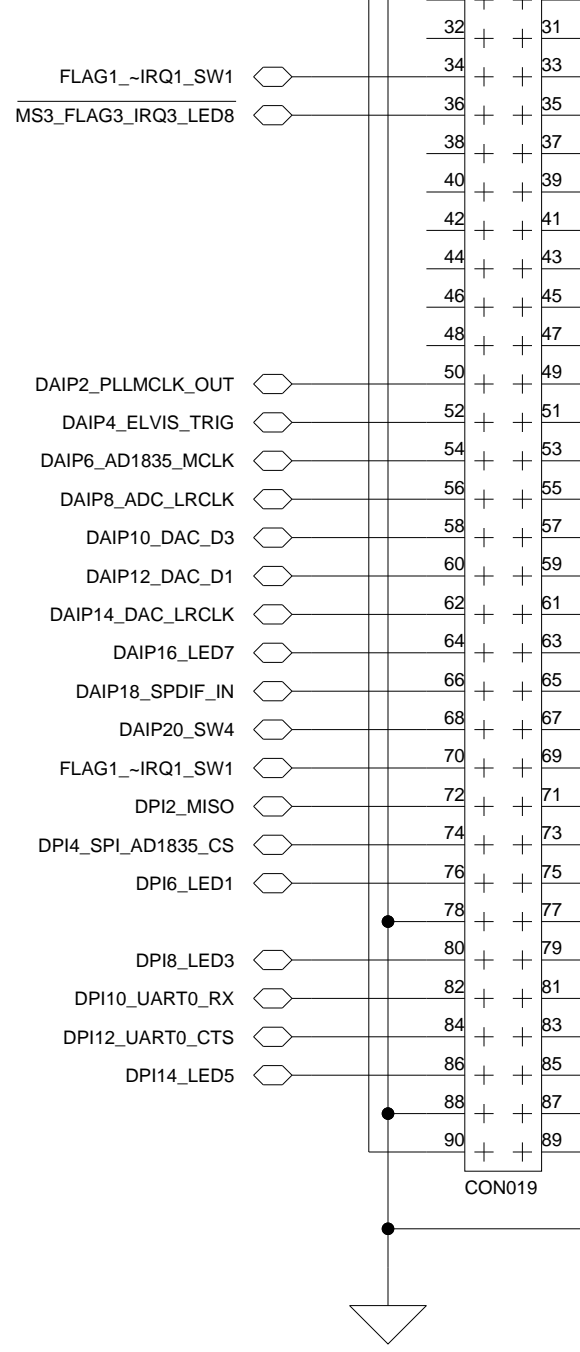

4

A

B

2

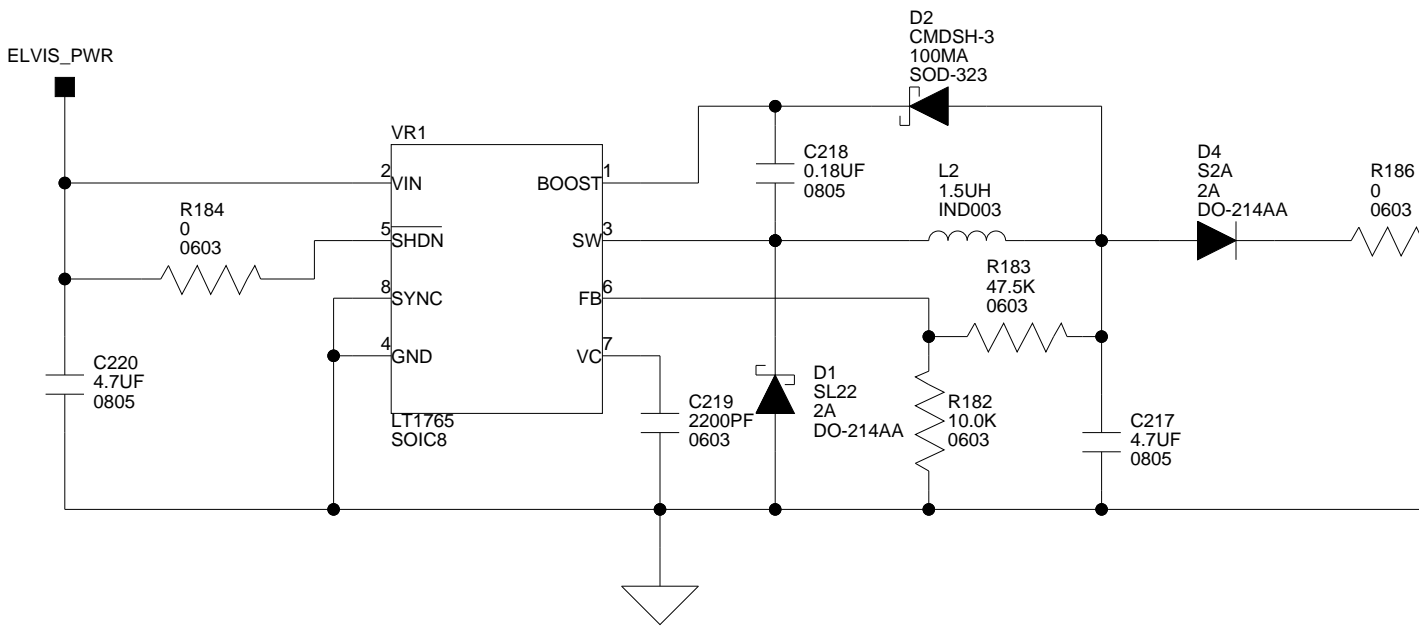

3

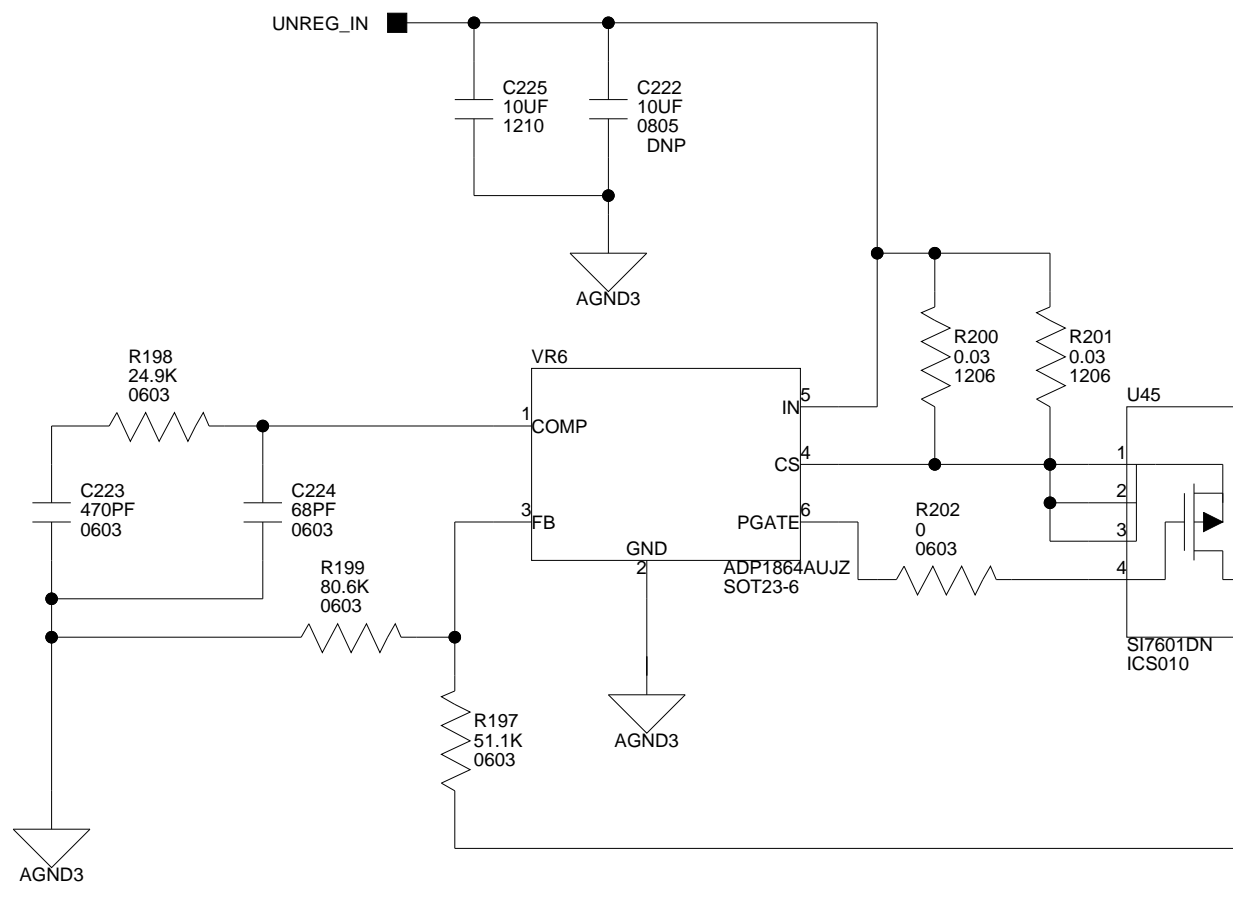

4

A

B

# I INDEX

## Numerics

2-wire interface (TWI) mode, [1-14](#)

## A

AD1835A, CAD and DAC  
  configuration registers, [1-15](#)  
  DAI interface, [1-15](#)  
  disconnect switch (SW15), [2-14](#)  
  DPI interface, [2-5](#)  
  master clock (MCLK), [2-4](#), [2-10](#)  
  master/slave modes, [1-15](#), [2-10](#)  
  setup switch (SW3), [2-10](#)  
ADC\_DATA pins, [2-10](#)  
ADDR23-0 pins, [2-7](#)  
AMP\_LEFT\_IN signals, [2-12](#)  
AMP\_RIGHT\_IN signals, [2-12](#)  
analog audio, *See* audio, AD1835A  
analog-to-digital converters (ADCs), *See*  
  AD1835A  
architecture, of this EZ-KIT Lite, [2-2](#)  
async memory controller, [1-13](#)  
audio  
  codecs, *See* AD1835A  
  in RCA connector (J10), [2-21](#)  
  interface, [xi](#), [1-14](#)  
  oscillators, [2-4](#), [2-10](#)  
  out RCA connector (J5), [2-22](#)

## B

bill of materials, [A-1](#)  
board design database, [1-17](#)  
board schematic (ADSP-21371), [B-1](#)  
boot  
  configuration pins (BOOTCFG1-0),  
    [2-9](#)  
  modes, [2-3](#), [2-9](#)

## C

CLKCFG1-0 pins, [2-3](#), [2-9](#)  
CLKIN pins, [2-3](#), [2-9](#)  
clock  
  multiplier ratios, [2-9](#)  
  routing signals, [2-10](#)  
codec  
  *See also* AD1835A  
  disconnect switch (SW15), [2-14](#)  
  setup switch (SW7), [2-10](#)  
connectors  
  diagram of locations, [2-20](#)  
  J10 (audio in RCA), [1-15](#), [2-21](#)  
  J1-3 (expansion), [2-3](#), [2-4](#), [2-6](#), [2-7](#), [2-21](#)  
  J4 (power), [1-8](#), [2-22](#)  
  J5 (audio out RCA), [1-15](#), [2-22](#)  
  J6 (RS-232), [xi](#)  
  J7-8 (S/PDIF coax), [2-23](#)  
  J9 (headphone out), [1-15](#), [2-22](#)  
  P3 (DPI header), [2-23](#)  
  P4 (DAI header), [2-24](#)  
  ZP4 (JTAG), [2-7](#), [2-24](#)

## Index

contents, of this EZ-KIT Lite package, [1-2](#)  
core  
  clock rates, [2-9](#)  
  frequency, [2-3](#)  
  to CLKIN ratios, [2-9](#)  
  voltage, [2-2](#)  
current limits, [2-7](#)

### D

DAC1-0 signals, [2-13](#)  
DAI  
  block diagram, [2-3](#)  
  connections, [1-15](#), [1-16](#), [2-15](#)  
  data transfer from codec, [1-14](#)  
  disabling (SW3), [2-4](#), [2-10](#)  
  header (P4), [2-4](#), [2-24](#)  
DAI16-15 pins, [1-16](#)  
DAI20-19 pins, [2-12](#), [2-16](#)  
DAI4 pins, [2-19](#)  
DAIP20-11 pins, [2-7](#)  
DATA31-0 pins, [2-7](#)  
data acquisition (DAQ) devices, [1-14](#)  
DB9 connectors, [xi](#)  
default configuration, of this EZ-KIT Lite,  
  [1-3](#)  
digital peripheral interface, *See* DPI  
digital-to-analog converters (DACs), *See*  
  AD1835A  
DIP switch (SW7), [1-3](#), [1-15](#), [2-12](#), [2-16](#)  
DPI  
  block diagram, [2-5](#)  
  connections, [1-13](#), [1-16](#), [2-15](#)  
  disabling (SW2), [2-5](#)  
  header (P3), [2-5](#), [2-23](#)  
DPI12-10 pins, [2-7](#), [2-11](#)  
DPI14-13 pins, [1-16](#), [2-7](#)  
DPI2-1 (MOSI-0) pins, [1-13](#), [2-7](#)  
DPI3 (SPI clock) pins, [1-13](#), [2-7](#)

DPI4 pins, [1-15](#), [2-7](#)  
DPI5 (chip select) pins, [1-13](#), [2-7](#)  
DPI8-6 pins, [1-16](#), [2-7](#)

### E

electret microphone, [1-15](#), [2-11](#)  
ELVIS (Educational Laboratory Virtual  
  Instrumentation Suite)  
  interface, [1-13](#)  
  programmable flag jumper (JP4), [2-19](#)  
  select jumper (JP2), [2-18](#)  
  trigger pins, [2-19](#)  
  voltage select jumper (JP3), [2-19](#)  
EPROM/flash boot mode, [2-3](#)  
evaluation license  
  CCES, [1-10](#)  
example programs, [1-17](#)  
expansion interface, [2-3](#), [2-4](#), [2-6](#), [2-7](#), [2-21](#)  
external  
  memory, [1-12](#)  
  phase lock loop, *See* PLL  
  ports, [2-3](#), [2-9](#)

### F

features, of this EZ-KIT Lite, [x](#)  
FLAG0 pins, [1-16](#), [2-6](#), [2-7](#), [2-12](#), [2-16](#)  
FLAG1 pins, [2-6](#), [2-7](#)  
FLAG2 pins, [2-6](#), [2-7](#)  
FLAG3 pins, [1-17](#), [2-6](#), [2-7](#), [2-15](#)  
FLAG registers, [1-16](#)  
flash memory  
  boot mode (default), [2-9](#)  
  disconnect switch (SW15), [2-14](#)  
  start/end addresses, [1-12](#)  
  via external port, [1-12](#), [2-3](#)  
frame sync/clock signals, [1-15](#), [2-10](#)  
FUNCT\_OUT signals, [2-13](#)

**G**

general-purpose I/O pins, 1-15, 2-6, 2-15, 2-16

**H**

headphone out jack (J9), 2-22

**I**

installation, of this EZ-KIT Lite, 1-8  
     CCES, 1-4  
 interrupts, config push buttons as, 1-16  
 I/O voltage, 2-2  
 $\overline{\text{IRQ0-1}}$  pins, 1-16, 2-12, 2-16  
 $\overline{\text{IRQ3}}$  pins, 1-17

**J**

JTAG  
     emulation port, 2-7  
     header (ZP4), 2-24  
 jumpers  
     JP1 (VCO select), 2-18  
     JP2 (ELVIS select), 2-18  
     JP3 (voltage select), 2-19  
     JP4 (ELVIS programmable flag), 2-19  
     JP6 (ELVIS voltage), 2-19

**L**

LabVIEW virtual instruments, xi, 1-14  
 LEDs  
     diagram of locations, 2-14  
     LED10 (reset), 1-8, 2-15  
     LED1-7 (FLAGx I/O), 1-16, 2-15  
     LED8 (FLAG3), 1-16, 2-6, 2-15  
     LED9 (power), 1-8, 2-15  
     ZLED3 (USB monitor), 1-8, 2-15  
 LEFT\_IN signals, 2-13  
 LEFT\_OUT signals, 2-12, 2-13

license restrictions, 1-11  
 loop-back test switches (SW6, SW14), 2-11

**M**

$\overline{\text{M2-0}}$  memory select pins, 1-12  
 master input clock (MCLK), 1-14  
 $\overline{\text{MS3}}$  memory select pins, 1-12, 1-17

**N**

notation conventions, xviii

**O**

oscilloscope config switch (SW1), 2-12

**P**

package contents, 1-2  
 parallel flash memory, *See* flash memory  
 parallel port control signals, 2-7  
 phase lock loop (PLL), xii, 2-4, 2-18  
 PMCTL registers, 2-3  
 power  
     connector (J4), 2-22  
     LED (LED9), 2-15  
     specifications, 2-23  
     supply, 2-19, 2-23  
 push buttons  
     diagram of locations, 2-14  
     *See also* switches by name (SWx)  
     enable switch (SW7), 1-3, 1-15, 2-12, 2-16

**R**

RCA  
     cables, 1-3  
     connectors, xi, 1-15, 2-4

## Index

### reset

- LED (LED10), [2-15](#)
- push button (SW12), [2-16](#)

restrictions, of the evaluation license, [1-11](#)

RIGHT\_IN signals, [2-13](#)

RIGHT\_OUT signals, [2-12](#), [2-13](#)

RS-232 connector (J6), [xi](#)

## S

schematic, of ADSP-21371 EZ-KIT Lite,

[B-1](#)

### SDRAM

- chip select pin (FLAG8), [2-6](#)
- controller, [1-12](#)
- control signals, [2-7](#)
- via external port, [2-3](#)

serial peripheral interface, *See* SPI

setup, of this EZ-KIT Lite, [1-3](#)

signal routing units

- SRU2 (DPI interface), [2-5](#)
- SRU (DAI interface), [2-3](#)

spacing headers, [2-24](#)

### SPI

- flash memory, [1-12](#), [2-5](#)
- master/slave boot modes, [2-3](#), [2-9](#)
- port, [1-13](#), [1-15](#)

startup, of this EZ-KIT Lite, [1-8](#)

CCES, [1-4](#)

SW12 (reset) push button, [2-16](#)

SW13 (ELVIS station) switch, [2-13](#)

SW14 (test) switch, [2-11](#)

SW15 (AD1835A and flash disconnect) switch, [2-14](#)

SW1 (oscilloscope) switch, [2-12](#)

SW2 (boot mode select) switch, [2-3](#), [2-6](#), [2-9](#)

SW3 (AD1835A codec) switch, [2-4](#), [2-10](#)

SW4 (microphone) switch, [1-15](#), [2-11](#)

SW6 (test) switch, [2-11](#)

SW7 (push button enable) DIP switch, [1-3](#), [1-15](#), [2-12](#), [2-16](#)

SW8-11 (general input) push buttons, [2-16](#)

synchronous dynamic random access memory, *See* SDRAM

system architecture, of this EZ-KIT Lite, [2-2](#)

## T

technical support, [xiv](#)

test switches (SW6, SW14), [2-11](#)

time-division multiplexed (TDM) mode, [1-14](#)

## U

### UART

interface, [xi](#), [2-5](#)

enable switch (SW5)

universal asynchronous

receiver/transmitter, *See* UART

### USB

interface, [2-7](#), [2-24](#)

cable, [1-2](#), [1-8](#), [2-15](#), [2-16](#)

interface chip (U34), [2-16](#)

monitor LED (ZLED3), [1-8](#), [2-15](#)

## V

VisualDSP++

environment, [1-9](#)

voltage-controlled oscillator select jumper (JP1), [2-18](#)

## X-ON Electronics

Largest Supplier of Electrical and Electronic Components

*Click to view similar products for [Development Boards & Kits - Other Processors](#) category:*

*Click to view products by [Analog Devices](#) manufacturer:*

Other Similar products are found below :

[EVB-MEC1418MECC](#) [20-101-1252](#) [C29XPCIE-RDB](#) [CC-ACC-18M433](#) [MAX1464EVKIT](#) [RTE510Y470TGB00000R](#)  
[RTK0EN0001D01001BZ](#) [MAXQ622-KIT#](#) [YR0K505231S000BE](#) [YR0K50571MS000BE](#) [YQB-R5F1057A-TB](#) [QB-R5F104PJ-TB](#) [CC-](#)  
[ACC-ETHMX](#) [OV-7604-C7-EVALUATION-BOARD](#) [SK-AD02-D62Q1747TB](#) [SK-BS01-D62Q1577TB](#) [ST7MDT1-EMU2](#) [GROVE BASE](#)  
[KIT FOR RASPBERRY PI](#) [RTK5572TKCS00000BE](#) [CAB M-M\(40-17-RAINBOW\)](#) [CY8CKIT-143A](#) [RASPBERRY PI PICO](#) [EK-](#)  
[MPC5744P](#) [KITAURIXTC234TFTTOBO1](#) [ENW89854AXKF](#) [ENWF9201AVEF](#) [QB-R5F104LE-TB](#) [LV18F V6 64-80-PIN TQFP MCU](#)  
[CARD EMPTY](#) [LV-24-33 V6 44-PIN TQFP MCU CARD EMPTY](#) [LV-24-33 V6 64-PIN TQFP MCU CARD EMPTY](#) [LV-24-33 V6 80-PIN](#)  
[TQFP 1 MCU CARD EMPTY](#) [32X32 RGB LED MATRIX PANEL - 6MM PITCH](#) [3.3 - 5 VTRANSLATOR](#) [READY FOR XMEGA](#)  
[CASING \(WHITE\)](#) [RELAY4 BOARD](#) [ETHERNET CONNECTOR](#) [RFID CARD 125KHZ - TAG](#) [RFID READER](#) [RFM12B-DEMO](#)  
[MAROON](#) [3G CLICK \(FOR EUROPE AND AUSTRALIA\)](#) [MAX232](#) [MAX3232 BOARD](#) [ARTY S7-50](#) [THREE-AXIS](#)  
[ACCELEROMETER BOARD](#) [TINKERKIT HALL SENSOR](#) [TOUCHPANEL](#) [TOUCHPANEL CONTROLLER](#) [MIKROBOARD FOR AVR](#)  
[WITH ATMEGA128](#) [MIKROBOARD FOR PSOC WITH CY8C27643](#)