

ADSP-21469 EZ-Board® Evaluation System Manual

Revision 1.1, July 2012

Part Number
82-000221-01

Analog Devices, Inc.
One Technology Way
Norwood, Mass. 02062-9106



Copyright Information

© 2012 Analog Devices, Inc., ALL RIGHTS RESERVED. This document may not be reproduced in any form without prior, express written consent from Analog Devices, Inc.

Printed in the USA.

Disclaimer

Analog Devices, Inc. reserves the right to change this product without prior notice. Information furnished by Analog Devices is believed to be accurate and reliable. However, no responsibility is assumed by Analog Devices for its use; nor for any infringement of patents or other rights of third parties which may result from its use. No license is granted by implication or otherwise under the patent rights of Analog Devices, Inc.

Trademark and Service Mark Notice

The Analog Devices logo, CrossCore, EngineerZone, EZ-Extender, EZ-KIT Lite, SHARC, and VisualDSP++ are registered trademarks of Analog Devices, Inc.

All other brand and product names are trademarks or service marks of their respective owners.

Regulatory Compliance

The ADSP-21469 EZ-Board is designed to be used solely in a laboratory environment. The board is not intended for use as a consumer end product or as a portion of a consumer end product. The board is an open system design which does not include a shielded enclosure and therefore may cause interference to other electrical devices in close proximity. This board should not be used in or near any medical equipment or RF devices.

The ADSP-21469 EZ-Board has been certified to comply with the essential requirements of the European EMC directive 2004/108/EC and therefore carries the “CE” mark.

The ADSP-21469 EZ-Board has been appended to Analog Devices, Inc. EMC Technical File (EMC TF) referenced **DSPTOOLS1**, issue 2 dated June 4, 2008 and was declared CE compliant by an appointed Notified Body (No.0673) as listed below.

Notified Body Statement of Compliance: Z600ANA2.033, dated May 2009.

Issued by: Technology International (Europe) Limited
60 Shrivenham Hundred Business Park
Shrivenham, Swindon, SN6 8TY, UK



The EZ-Board evaluation system contains ESD (electrostatic discharge) sensitive devices. Electrostatic charges readily accumulate on the human body and equipment and can discharge without detection. Permanent damage may occur on devices subjected to high-energy discharges. Proper ESD precautions are recommended to avoid performance degradation or loss of functionality. Store unused EZ-Board boards in the protective shipping package.



CONTENTS

PREFACE

| | |
|---------------------------------|-------|
| Product Overview | xii |
| Purpose of This Manual | xv |
| Intended Audience | xv |
| Manual Contents | xv |
| What's New in This Manual | xvi |
| Technical Support | xvi |
| Supported Processors | xvii |
| Product Information | xviii |
| Analog Devices Web Site | xviii |
| EngineerZone | xix |
| Related Documents | xix |
| Notation Conventions | xx |

USING THE ADSP-21469 EZ-BOARD

| | |
|--|-----|
| Package Contents | 1-2 |
| Default Configuration | 1-3 |
| CCES Install and Session Startup | 1-5 |
| Session Startup | 1-6 |

Contents

| | |
|---|------|
| VisualDSP++ Install and Session Startup | 1-9 |
| Session Startup | 1-10 |
| CCES Evaluation License | 1-11 |
| VisualDSP++ Evaluation License | 1-12 |
| Memory Map | 1-13 |
| DDR2 Interface | 1-14 |
| Parallel Flash Memory Interface | 1-15 |
| SPI Interface | 1-16 |
| Link Port Interface | 1-16 |
| Temperature Sensor Interface | 1-17 |
| S/PDIF Interface | 1-18 |
| Audio Interface | 1-19 |
| UART Interface | 1-20 |
| LEDs and Push Buttons | 1-21 |
| JTAG Interface | 1-23 |
| Land Grid Array | 1-24 |
| Expansion Interface II | 1-25 |
| Power Measurements | 1-26 |
| Power-On-Self Test | 1-26 |
| Example Programs | 1-27 |
| Board Design Database | 1-27 |

ADSP-21469 EZ-BOARD HARDWARE REFERENCE

| | |
|---|------|
| System Architecture | 2-2 |
| DAI Interface | 2-3 |
| DPI Interface | 2-4 |
| Flags and Memory Selects | 2-5 |
| Push Button and Switch Settings | 2-7 |
| DAI [1–8] Enable Switch (SW1) | 2-8 |
| DAI [9–16] Enable Switch (SW2) | 2-8 |
| DPI [1–8] Enable Switch (SW3) | 2-9 |
| Boot Mode Select Switch (SW4) | 2-10 |
| DSP Clock Configuration Switch (SW5) | 2-11 |
| DAI [17–20] Enable Switch (SW7) | 2-11 |
| Programmable Flag Push Buttons (SW8–11) | 2-12 |
| Reset Push Button (SW12) | 2-12 |
| Asynchronous Control Enable Switch (SW13) | 2-13 |
| DPI [9–14] Enable Switch (SW14) | 2-13 |
| Audio In1 Left Selection Switch (SW15) | 2-14 |
| Audio In1 Right Selection Switch (SW16) | 2-15 |
| Audio In2 Right Selection Switch (SW17) | 2-15 |
| Audio In2 Left Selection Switch (SW18) | 2-16 |
| JTAG Switches (SW19–22) | 2-17 |
| Headphone Enable Switch (SW23) | 2-19 |
| Audio Loopback Switches (SW24–25) | 2-19 |

Contents

| | |
|--|------|
| Jumpers | 2-20 |
| Flash WP Jumper (JP1) | 2-21 |
| S/PDIF Loopback Jumper (JP2) | 2-21 |
| UART RTS/CTS Jumper (JP3) | 2-21 |
| UART Loopback Jumper (JP4) | 2-21 |
| LEDs | 2-22 |
| GPIO LEDs (LED1–8) | 2-23 |
| Power LED (LED9) | 2-23 |
| Reset LED (LED10) | 2-23 |
| Thermal Limit LED (LED11) | 2-24 |
| Connectors | 2-25 |
| Expansion Interface II Connector (J1) | 2-26 |
| RS-232 Connector (J2) | 2-26 |
| Link Port 1 Connector (J3) | 2-26 |
| RCA Audio Connector (J4) | 2-27 |
| RCA Audio Connector (J5) | 2-27 |
| S/PDIF IN Connector (J6) | 2-27 |
| S/PDIF OUT Connector (J7) | 2-27 |
| Headphone Out Connector (J8) | 2-28 |
| JTAG Connector (P1) | 2-28 |
| Expansion Interface II Connector (P2) | 2-28 |
| DMAX Land Grid Array Connectors (P5–7) | 2-29 |
| Differential In/Out Connectors (P8–9) | 2-29 |
| MLB Connector (P10) | 2-29 |

| | |
|--|------|
| Link Port 0 Connector (P12) | 2-30 |
| VDD_DDR2 Power Connector (P13) | 2-30 |
| VDDINT Power Connector (P14) | 2-30 |
| VDDEXT Power Connector (P15) | 2-30 |
| Power Connector (P16) | 2-31 |
| Standalone Debug Agent Connector (ZP1) | 2-31 |

ADSP-21469 EZ-BOARD BILL OF MATERIALS

ADSP-21469 EZ-BOARD SCHEMATIC

INDEX

Contents

PREFACE

Thank you for purchasing the ADSP-21469 EZ-Board[®], Analog Devices, Inc. evaluation system for SHARC[®] processors.

SHARC processors are based on a 32-bit super Harvard architecture that includes a unique memory architecture comprised of two large on-chip, dual-ported SRAM blocks coupled with a sophisticated IO processor, which gives a SHARC processor the bandwidth for sustained high-speed computations. SHARC processors represents today's de facto standard for floating-point processing, targeted toward premium audio applications.

The evaluation board is designed to be used in conjunction with the CrossCore[®] Embedded Studio (CCES) and VisualDSP++[®] development environments to test the capabilities of the ADSP-21469 SHARC processors. The development environment aids advanced application code development and debug, such as:

- Create, compile, assemble, and link application programs written in C++, C, and ADSP-21469 assembly
- Load, run, step, halt, and set breakpoints in application programs
- Read and write data and program memory
- Read and write core and peripheral registers
- Plot memory

Access to the ADSP-21469 processor from a personal computer (PC) is achieved through a USB port or an external JTAG emulator. The USB interface of the standalone debug agent gives unrestricted access to the

Product Overview

ADSP-21469 processor and evaluation board's peripherals. Analog Devices JTAG emulators offer faster communication between the host PC and target hardware. To learn more about Analog Devices emulators and processor development tools, go to <http://www.analog.com/dsp/tools>.

The ADSP-21469 EZ-Board provides example programs to demonstrate the capabilities of the product.

Product Overview

The board features:

- Analog Devices ADSP-21469 SHARC processor
 - Core performance up to 450 MHz
 - 324-pin PBGA package
 - 25 MHz oscillator
 - 5 Mb of internal RAM memory
- Double data rate synchronous dynamic random access memory (DDR2)
 - Micron MT47H64M16HR-3 – 128 MB (64M x 16 bits)
 - Performance of up to 225 MHz clock rate
- Parallel flash memory
- Numonyx M29W320EB – 4 MB (4M x 8 bits)

- SPI flash memory
 - Numonyx M25P16 – 16 Mb
- Analog audio interface
 - Analog Devices AD1939 audio codec
 - Eight DAC outputs for four channels of stereo output
 - Four ADC inputs for two channels of stereo input
 - Two DB25 connectors for differential inputs/outputs
 - 3.5 mm headphone jack with volume control connected to one of the stereo outputs
 - Supports all eight DACs and four ADCs in TDM and I²S modes at 48 KHz, 96 KHz, and 192 KHz sample rates
- Digital audio interface (S/PDIF)
 - RCA phono jack output
 - RCA phono jack input
- Link port interface
 - Two Samtec ERF8/ERM8 series connectors
 - Link ports performance up to 166 MHz
 - Two EZ-Boards can mate with no cables required
- Temperature monitor
 - ON Semiconductor ADM1032
 - Local and remote temperature sensing

Product Overview

- Universal asynchronous receiver/transmitter (UART)
 - ADM3202 RS-232 line driver/receiver
 - DB9 female connector
- LEDs
 - Eleven LEDs: one board reset (red), eight general-purpose (amber), one temperature sensor LED (amber), and one power (green)
- Push buttons
 - Five push buttons: one reset, two connected to DAI, two connected to FLAG pins of the processor
- Expansion interface II
 - Next generation of the expansion interface design, provides access to most of the ADSP-21469 processor signals
- Land grid array
 - Easy probing of all port pins and most asynchronous memory interface (AMI) signals
- Other features
 - JTAG ICE 14-pin header
 - SHARC power measurement jumpers

Please visit www.analog.com/21469EZBoard for additional information, including CCES support.

For information about the hardware components of the EZ-Board, refer to “[ADSP-21469 EZ-Board Hardware Reference](#)” on page 2-1.

Purpose of This Manual

The *ADSP-21469 EZ-Board Evaluation System Manual* provides instructions for installing the product hardware (board). The text describes operation and configuration of the board components and provides guidelines for running your own code on the ADSP-21469 EZ-Board. Finally, a schematic and a bill of materials are provided for reference.

Intended Audience

The primary audience for this manual is a programmer who is familiar with Analog Devices processors. This manual assumes that the audience has a working knowledge of the appropriate processor architecture and instruction set.

Programmers who are unfamiliar with Analog Devices processors can use this manual, but should supplement it with other texts that describe your target architecture. For the locations of these documents, see [“Related Documents”](#).

Programmers who are unfamiliar with CCES or VisualDSP++ should refer to the online help and user’s manuals.

Manual Contents

The manual consists of:

- Chapter 1, [“Using the ADSP-21469 EZ-Board”](#) on page 1-1
Describes EZ-Board functionality from a programmer’s perspective and provides an easy-to-access memory map.
- Chapter 2, [“ADSP-21469 EZ-Board Hardware Reference”](#) on page 2-1
Provides information on the EZ-Board hardware components.

What's New in This Manual

- Appendix A, “[ADSP-21469 EZ-Board Bill Of Materials](#)” on [page A-1](#)
Provides a list of components used to manufacture the EZ-Board.
- Appendix B, “[ADSP-21469 EZ-Board Schematic](#)” on [page B-1](#)
Provides the resources to allow EZ-Board board-level debugging or to use as a reference guide. Appendix B is part of the online help.

What's New in This Manual

This is revision 1.1 of the *ADSP-21469 EZ-Board Evaluation System Manual*. The manual has been updated to include CCES information.

For the latest version of this manual, please refer to the Analog Devices Web site.

Technical Support

You can reach Analog Devices processors and DSP technical support in the following ways:

- Post your questions in the processors and DSP support community at EngineerZone[®]:
<http://ez.analog.com/community/dsp>
- Submit your questions to technical support directly at:
<http://www.analog.com/support>

- E-mail your questions about processors, DSPs, and tools development software from **CrossCore Embedded Studio** or **VisualDSP++**:

Choose **Help > Email Support**. This creates an e-mail to processor.tools.support@analog.com and automatically attaches your **CrossCore Embedded Studio** or **VisualDSP++** version information and `license.dat` file.

- E-mail your questions about processors and processor applications to:
processor.support@analog.com or
processor.china@analog.com (Greater China support)
- In the **USA only**, call **1-800-ANALOGD** (1-800-262-5643)
- Contact your Analog Devices sales office or authorized distributor. Locate one at:
www.analog.com/adi-sales
- Send questions by mail to:
Processors and DSP Technical Support
Analog Devices, Inc.
Three Technology Way
P.O. Box 9106
Norwood, MA 02062-9106
USA

Supported Processors

This evaluation system supports Analog Devices ADSP-21462, ADSP-21465, ADSP-21467, and ADSP-21469 SHARC processors.

Product Information

Product information can be obtained from the Analog Devices Web site and the online help system.

Analog Devices Web Site

The Analog Devices Web site, www.analog.com, provides information about a broad range of products—analog integrated circuits, amplifiers, converters, and digital signal processors.

To access a complete technical library for each processor family, go to http://www.analog.com/processors/technical_library. The manuals selection opens a list of current manuals related to the product as well as a link to the previous revisions of the manuals. When locating your manual title, note a possible errata check mark next to the title that leads to the current correction report against the manual.

Also note, [myAnalog](#) is a free feature of the Analog Devices Web site that allows customization of a Web page to display only the latest information about products you are interested in. You can choose to receive weekly e-mail notifications containing updates to the Web pages that meet your interests, including documentation errata against all manuals. [myAnalog](#) provides access to books, application notes, data sheets, code examples, and more.

Visit [myAnalog](#) (found on the Analog Devices home page) to sign up. If you are a registered user, just log on. Your user name is your e-mail address.

EngineerZone

EngineerZone is a technical support forum from Analog Devices. It allows you direct access to ADI technical support engineers. You can search FAQs and technical information to get quick answers to your embedded processing and DSP design questions.

Use EngineerZone to connect with other DSP developers who face similar design challenges. You can also use this open forum to share knowledge and collaborate with the ADI support team and your peers. Visit <http://ez.analog.com> to sign up.

Related Documents



For additional information about the product, refer to the following publications.

Table 1. Related Processor Publications

| Title | Description |
|---|---|
| <i>ADSP-21467/ADSP-21469 SHARC Processor Data Sheet</i> | General functional description, pinout, and timing of the processor |
| <i>ADSP-214xx SHARC Processor Hardware Reference</i> | Description of the internal processor architecture, registers, and all peripheral functions |
| <i>SHARC Processor Programming Reference</i> | Description of all allowed processor assembly instructions |

Notation Conventions

Text conventions used in this manual are identified and described as follows.

| Example | Description |
|---|--|
| Close command (File menu) | Titles in reference sections indicate the location of an item within the development environment's menu system (for example, the Close command appears on the File menu). |
| {this that} | Alternative required items in syntax descriptions appear within curly brackets and separated by vertical bars; read the example as <i>this</i> or <i>that</i> . One or the other is required. |
| [this that] | Optional items in syntax descriptions appear within brackets and separated by vertical bars; read the example as an optional <i>this</i> or <i>that</i> . |
| [this,...] | Optional item lists in syntax descriptions appear within brackets delimited by commas and terminated with an ellipsis; read the example as an optional comma-separated list of <i>this</i> . |
| .SECTION | Commands, directives, keywords, and feature names are in text with letter gothic font. |
| <i>filename</i> | Non-keyword placeholders appear in text with italic style format. |
|  | Note: For correct operation, ... A Note provides supplementary information on a related topic. In the online version of this book, the word Note appears instead of this symbol. |
|  | Caution: Incorrect device operation may result if ... Caution: Device damage may result if ... A Caution identifies conditions or inappropriate usage of the product that could lead to undesirable results or product damage. In the online version of this book, the word Caution appears instead of this symbol. |
|  | Warning: Injury to device users may result if ... A Warning identifies conditions or inappropriate usage of the product that could lead to conditions that are potentially hazardous for the devices users. In the online version of this book, the word Warning appears instead of this symbol. |

1 USING THE ADSP-21469 EZ-BOARD

This chapter provides specific information to assist you with development of programs for the ADSP-21469 EZ-Board evaluation system.

The following topics are covered.

- “Package Contents” on page 1-2
- “Default Configuration” on page 1-3
- “CCES Install and Session Startup” on page 1-5
- “VisualDSP++ Install and Session Startup” on page 1-9
- “CCES Evaluation License” on page 1-11
- “VisualDSP++ Evaluation License” on page 1-12
- “Memory Map” on page 1-13
- “DDR2 Interface” on page 1-14
- “Parallel Flash Memory Interface” on page 1-15
- “SPI Interface” on page 1-16
- “Link Port Interface” on page 1-16
- “Temperature Sensor Interface” on page 1-17
- “S/PDIF Interface” on page 1-18
- “Audio Interface” on page 1-19

Package Contents

- “UART Interface” on page 1-20
- “LEDs and Push Buttons” on page 1-21
- “JTAG Interface” on page 1-23
- “Land Grid Array” on page 1-24
- “Expansion Interface II” on page 1-25
- “Power Measurements” on page 1-26
- “Power-On-Self Test” on page 1-26
- “Example Programs” on page 1-27
- “Board Design Database” on page 1-27

For information on the graphical user interface, including the boot loading, target options, and other facilities, refer to the online help.

For more information about the ADSP-21469 SHARC processor, see documents referenced in [“Related Documents”](#).

Package Contents

Your ADSP-21469 EZ-Board evaluation system package contains the following items.

- ADSP-21469 EZ-Board
- Universal 5.0V DC power supply
- 3.5 mm stereo headphones
- 6-foot RCA audio cable

- 6-foot 3.5 mm/RCA x 2 Y-cable
- 3.5 mm stereo female to RCA male Y-cable

If any item is missing, contact the vendor where you purchased your EZ-Board or contact Analog Devices, Inc.

Default Configuration

The EZ-Board evaluation system contains ESD (electrostatic discharge) sensitive devices. Electrostatic charges readily accumulate on the human body and equipment and can discharge without detection. Permanent damage may occur on devices subjected to high-energy discharges. Proper ESD precautions are recommended to avoid performance degradation or loss of functionality. Store unused EZ-Board in the protective shipping package.



The ADSP-21469 EZ-Board is designed to run outside your personal computer as a standalone unit. You do not have to open your computer case.

When removing the EZ-Board from the package, handle the board carefully to avoid the discharge of static electricity, which can damage some components. [Figure 1-1](#) shows the default jumper and switch settings, connector locations, and LEDs used in installation. Confirm that your board is in the default configuration before using the board.

Default Configuration

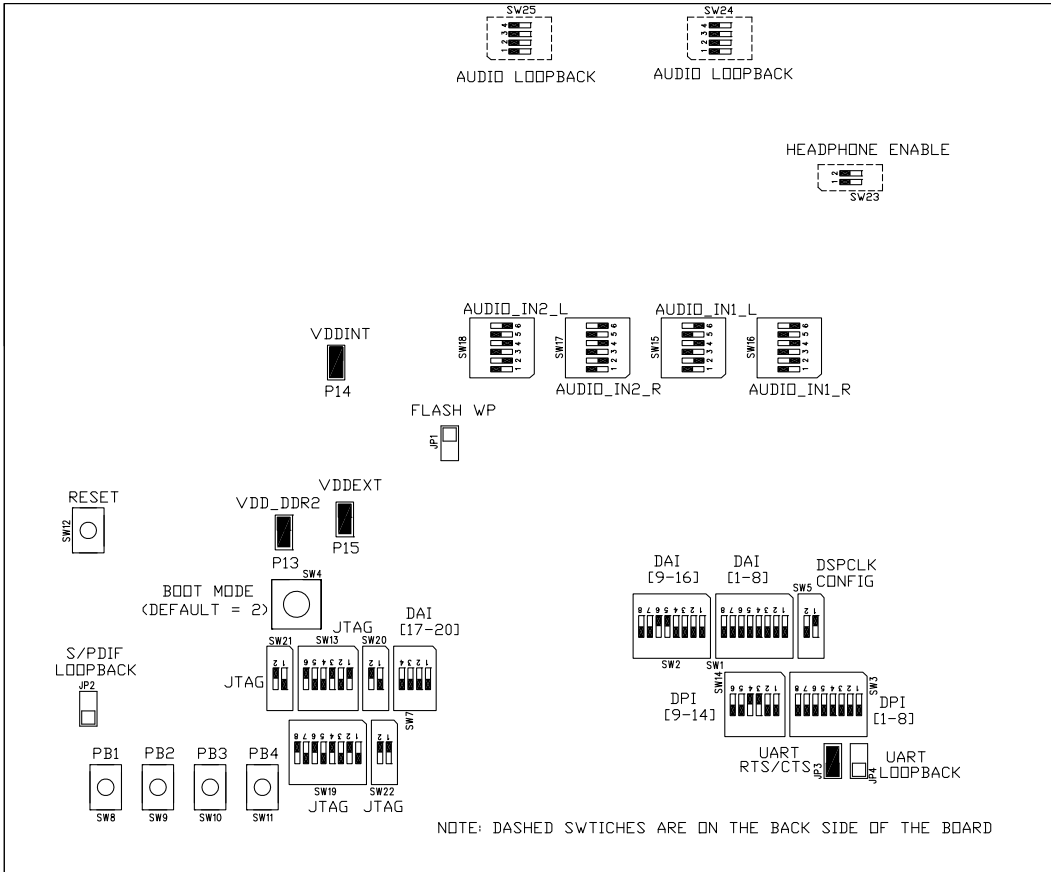

Figure 1-1. Default EZ-Board Hardware Setup

CCES Install and Session Startup

For information about CCES and to download the software, go to www.analog.com/CCES. A link for the ADSP-21469 EZ-Board Support Package (BSP) for CCES can be found at <http://www.analog.com/SHARC/EZKits>.

Follow these instructions to ensure correct operation of the product software and hardware.

Step 1: Connect the EZ-Board to a personal computer (PC) running CCES using one of two options: an Analog Devices emulator or via the debug agent.

Using an Emulator:

1. Plug one side of the USB cable into the USB connector of the emulator. Plug the other side into a USB port of the PC running CCES.
2. Attach the emulator to the header connector P1 (labeled JTAG) on the EZ-Board.

Using the standalone Debug Agent:

1. Attach the standalone debug agent to connectors ZP1 and ZP4 of the EZ-Board.
2. Plug one side of the provided USB cable into the USB connector of the debug agent ZP1 (labeled USB). Plug the other side of the cable into a USB port of the PC running CCES.

CCES Install and Session Startup

Step 2: Attach the provided cord and appropriate plug to the 5V power adaptor.

1. Plug the jack-end of the power adaptor into the power connector P16 (labeled 5V) on the EZ-Board.
2. Plug the other side of the power adaptor into a power outlet. The power LED (labeled LED9) is lit green when power is applied to the board.
3. Power the emulator (if used). Plug the jack-end of the assembled power adaptor into the emulator and plug the other side of the power adaptor into a power outlet. The enable/power indicator is lit green when power is applied.

Step 3 (if connected through the debug agent): Verify that the yellow USB monitor LED (labeled LED2) and the green power LED (labeled LED1) on the debug agent are both on. This signifies that the board is communicating properly with the host PC and ready to run CCES.

Session Startup

It is assumed that the CrossCore Embedded Studio software is installed and running on your PC.



Note: If you connect the board or emulator first (before installing CCES) to the PC, the Windows driver wizard may not find the board drivers.

1. Navigate to the CCES environment via the **Start** menu.

Note that CCES is not connected to the target board.

2. Use the system configuration utility to connect to the EZ-Board.

If a debug configuration exists already, select the appropriate configuration and click **Apply and Debug** or **Debug**. Go to step 8.

To create a debug configuration, do one of the following:

- Click the down arrow next to the little bug icon, select **Debug Configurations**
- Choose **Run > Debug Configurations**.

The **Debug Configuration** dialog box appears.

3. Select **CrossCore Embedded Studio Application** and click  (New launch configuration).

The **Select Processor** page of the **Session Wizard** appears.

4. Ensure **Blackfin** is selected in **Processor family**. In **Processor type**, select **ADSP-21469**. Click **Next**.

The **Select Connection Type** page of the **Session Wizard** appears.

5. Select one of the following:
 - For standalone debug agent connections, **EZ-Board** and click **Next**.
 - For emulator connections, **Emulator** and click **Next**.

The **Select Platform** page of the **Session Wizard** appears.



CCES Install and Session Startup

6. Do one of the following:
 - For standalone debug agent connections, ensure that the selected platform is **ADSP-21469 EZ-Board** via Debug Agent.
 - For emulator connections, choose the type of emulator that is connected to the board.
7. Click **Finish** to close the wizard.

The new debug configuration is created and added to the program(s) to load list.

8. In the **Program(s) to load** section, choose the program to load when connecting to the board. If not loading any program upon connection to the target, do not make any changes.

Note that while connected to the target, there is no way to choose a program to download. To load a program once connected, terminate the session.

 To delete a configuration, go to the **Debug Configurations** dialog box and select the configuration to delete. Click  and choose **Yes** when asked if you wish to delete the selected launch configuration. Then **Close** the dialog box.

 To disconnect from the target board, click the terminate button (red box) or choose **Run > Terminate**.

To delete a session, choose **Target > Session > Session List**. Select the session name from the list and click **Delete**. Click **OK**.

VisualDSP++ Install and Session Startup

For information about VisualDSP++ and to download the software, go to www.analog.com/VisualDSP.

There are two options to connect the EZ-Board hardware to a personal computer (PC) running VisualDSP++: via an Analog Devices emulator or via a standalone debug agent module. The standalone debug agent allows a debug agent to interface to the ADSP-21469 EZ-Board. The standalone debug agent is shipped with the kit.

To connect the EZ-Board to a PC via an emulator:

1. Plug the 5V adaptor into connector P16 (labeled 5.0V).
2. Attach the emulator header to connector P1 (labeled JTAG) on the back side of the EZ-Board.

To connect the EZ-Board to a PC via a standalone debug agent:



The debug agent can be used only when power is supplied from the wall adaptor.

1. Attach the standalone debug agent to connectors P1 (labeled JTAG) and ZP1 on the backside of the EZ-Board, watching for the keying pin of P1 to connect correctly.
2. Plug the 5V adaptor into connector P16 (labeled 5.0V).
3. Plug one side of the provided USB cable into a USB connector of the standalone debug agent. Plug the other side of the cable into a USB port of the PC running VisualDSP++.
4. Verify that the yellow USB monitor LED on the standalone debug agent (LED4, located on the back side of the board) is lit. This signifies that the board is communicating properly with the host PC and ready to run VisualDSP++.

Session Startup

1. If you are running VisualDSP++ for the first time, navigate to the VisualDSP++ environment via the **Start > Programs** menu. The main window appears. Note that VisualDSP++ is not connected to any session. Skip the rest of this step to step 2.

If you have run VisualDSP++ previously, the last opened session appears on the screen. You can override the default behavior and force VisualDSP++ to start a new session by pressing and holding down the **Ctrl** key while starting VisualDSP++. Do not release the **Ctrl** key until the **Session Wizard** appears on the screen. Go to step 3.

2. To connect to a new EZ-Board session, start **Session Wizard** by selecting one of the following.
 - From the **Session** menu, **New Session**.
 - From the **Session** menu, **Session List**. Then click **New Session** from the **Session List** dialog box.
 - From the **Session** menu, **Connect to Target**.
3. The **Select Processor** page of the wizard appears on the screen. Ensure **SHARC** is selected in **Processor family**. In **Choose a target processor**, select **ADSP-21469**. Click **Next**.
4. The **Select Connection Type** page of the wizard appears on the screen. For standalone debug agent connections, select **EZ-Board** and click **Next**. For emulator connections, select **Emulator**, and click **Next**.
5. The **Select Platform** page of the wizard appears on the screen. For standalone debug agent connections, ensure that the selected platform is **ADSP-21469 EZ-Board via Debug Agent**. For emulator connections, choose the type of emulator that is connected.

Specify your own **Session name** for the session or accept the default name.

The session name can be a string of any length; although, the box displays approximately 32 characters. The session name can include space characters. If you do not specify a session name, VisualDSP++ creates a session name by combining the name of the selected platform with the selected processor. The only way to change a session name later is to delete the session and open a new session.

Click **Next**.

6. The **Finish** page of the wizard appears on the screen. The page displays your selections. Check the selections. If you are not satisfied, click **Back** to make changes; otherwise, click **Finish**. VisualDSP++ creates the new session and connects to the EZ-Board. Once connected, the main window's title is changed to include the session name set in step 5.



To disconnect from a session, click the disconnect button or select **Session > Disconnect from Target**.



To delete a session, select **Session > Session List**. Select the session name from the list and click **Delete**. Click **OK**.

CCES Evaluation License

The ADSP-21469 EZ-Board software is part of the Board Support Package (BSP) for the SHARC ADSP-2146x family. The EZ-Board is a licensed product that offers an unrestricted evaluation license for 90 days after activation. Once the evaluation period ends, the evaluation license becomes permanently disabled. If the evaluation license is installed but

VisualDSP++ Evaluation License

not activated, it allows 10 days of unrestricted use and then becomes disabled. The license can be re-enabled by activation.

An evaluation license can be upgraded to a full license. Licenses can be purchased from:

- Analog Devices directly. Call (800) 262-5645 or 781-937-2384 or go to:
<http://www.analog.com/buyonline>.
- Analog Devices, Inc. local sales office or authorized distributor. To locate one, go to:
<http://www.analog.com/salesdir/continent.asp>.

 The EZ-Board hardware must be connected and powered up to use CCES with a valid evaluation or full license.

VisualDSP++ Evaluation License

The ADSP-21469 EZ-Board installation is part of the VisualDSP++ installation. The EZ-Board is a licensed product that offers an unrestricted evaluation license for the first 90 days. Once the initial unrestricted 90-day evaluation license expires:

- VisualDSP++ restricts a connection to the ADSP-21469 EZ-Board via the USB port of the standalone debug agent interface only. Connections to simulators and emulation products are no longer allowed.
- The linker restricts a user program to 27306 words of memory for code space with no restrictions for data space.

 To avoid errors when opening VisualDSP++, the EZ-KIT Lite hardware must be connected and powered up. This is true for using VisualDSP++ with a valid evaluation or full license.

Memory Map

The ADSP-21469 processor has internal static random access memory (SRAM) for instructions and data storage; see [Table 1-1](#). The internal memory details can be found in the *ADSP-214xx SHARC Processor Hardware Reference*.

The ADSP-21469 EZ-Board includes three types of external memory: double data rate two synchronous dynamic random access memory (DDR2 SDRAM), serial peripheral interconnect (SPI) flash, and parallel flash. See [Table 1-2](#). For more information about a specific memory type, go to the respective section in this chapter.

Table 1-1. Processor Internal Memory Space

| Start Address | End Address | Contents |
|---------------|-------------|---------------|
| 0x0000 0000 | 0x0003 FFFF | IOP Registers |
| 0x0009 2000 | 0x0009 DFFF | BLOCK 0 RAM |
| 0x0009 E000 | 0x000B 1FFF | Reserved |
| 0x000B 2000 | 0x000B DFFF | BLOCK 1 RAM |
| 0x000B E000 | 0x000B FFFF | Reserved |
| 0x000C 0000 | 0x000C 7FFF | BLOCK 2 RAM |
| 0x000C 8000 | 0x000D FFFF | Reserved |
| 0x000E 0000 | 0x000E 7FFF | BLOCK 3 RAM |

DDR2 Interface

Table 1-2. EZ-Board External Memory Map

| Start Address | End Address | Content |
|----------------------------|----------------------------|--|
| 0x0020 0000 | 0x021F FFFF | DDR2 ($\overline{\text{DDR2CS0}}$) |
| 0x0400 0000 | 0x043F FFFF | Flash memory ($\overline{\text{MS1}}$) |
| 0x0800 0000 0x0800 0000 | 0x08FF FFFF 0x0BFF FFFF | Unused chip select ($\overline{\text{MS2}}$) for non-DDR2 addresses Unused chip select ($\overline{\text{DDR2_CS2}}$) for DDR2 addresses |
| 0x0C00 0000 0x0C00 0000 | 0x0CFF FFFF 0x0FFF FFFF | Unused chip select ($\overline{\text{MS3}}$) for non-DDR2 addresses Unused chip select ($\overline{\text{DDR2_CS3}}$) for DDR2 addresses |

DDR2 Interface

The ADSP-21469 processor connects to a 128 MB Micron MT47H64M16HR-3 chip through the DDR2 SDRAM controller. The DDR2 memory controller on the processor and DDR2 memory chip are powered by an on-board 1.8V regulator. Data is transferred between the processor and DDR2 on both the rising and falling edges of the DDR2 clock. The DDR2 controller on the processor can operate at a maximum clock frequency of half the processor's core clock. This equates to a DDR2 clock rate of 225 MHz, which is the ADSP-21469 processor limitation.

With a CCES or VisualDSP++ session running and connected to the EZ-Board via the USB standalone debug agent, the DDR2 registers are configured automatically each time the processor is reset. The values are used whenever DDR2 is accessed through the debugger (for example, when viewing memory windows or loading a program).

To disable the automatic setting of the SDRAM registers, do one of the following:

- CCES users, choose **Target > Settings > Target Options** and clear the **Use XML reset values** check box.
- VisualDSP++ users, choose **Settings > Target Options** and clear the **Use XML reset values** check box.

For more information on changing the reset values, refer to the online help.

An example program is included in the EZ-Board installation directory to demonstrate how to setup and access the DDR2 interface.

For more information on how to initialize the registers after a reset, search the online help for “reset values”.

Parallel Flash Memory Interface

The parallel flash memory interface of the ADSP-21469 EZ-Board contains a 4 MB (4M x 8 bits) Numonyx M29W320EB chip. Flash memory connects to the 8-bit data bus and address lines 0 through 21. Chip enable is decoded by the MS1 select line (default) through switch SW13 position 2; see “[Asynchronous Control Enable Switch \(SW13\)](#)” on page 2-13. To use the MS0 line instead of MS1 to interface to flash memory, make the respective change to SW13. The address range for flash memory is 0x0400 0000 to 0x043F FFFF.

Flash memory is pre-loaded with boot code for the power-on-self test (POST) program. For more information, refer to “[Power-On-Self Test](#)” on page 1-26.

By default, the EZ-Board boots from the 8-bit parallel flash memory. The processor boots from flash memory if the boot mode select switch (SW4) is set to position 2; see “[Boot Mode Select Switch \(SW4\)](#)” on page 2-10. Flash memory also is preloaded with configuration flash information, such as board revision, BOM revision, and other data.

Flash memory code can be modified. For instructions, refer to the online help and example program included in the EZ-Board installation directory.

For more information about the parallel flash device, refer to the Numonyx Web site: <http://www.numonyx.com>.

SPI Interface

The ADSP-21469 processor has two SPI ports which can be accessed via the digital peripheral interface (DPI) pins.

The SPI flash memory, a 16 Mb ST M25P16 device, connects to the SPI port of the processor and designates:

- DPI pin 5 (DPI_P5) as a chip select
- DPI pin 3 (DPI_P3) as the SPI clock
- DPI pin 1 (DPI_P1) as the master out slave in (MOSI) pin
- DPI pin 2 (DPI_P2) as the master in slave out (MISO) pin

The same SPI port and DPI pins connect to the serial flash memory and audio codec via switch SW3. See [“DPI \[1–8\] Enable Switch \(SW3\)” on page 2-9](#). The DPI pins also are available on the expansion interface II.

By default, the EZ-Board boots from the 8-bit flash parallel memory. SPI flash can be selected as the boot source by setting the boot mode select switch (SW4) to position 1. See [“Boot Mode Select Switch \(SW4\)” on page 2-10](#).

The audio codec is set up to use DPI pin 4 as the SPI chip select. For more information, refer to [“Audio Interface” on page 1-19](#).

Link Port Interface

The ADSP-21469 processor has two dedicated link ports. Each link port has a clock pin, an acknowledge pin, and eight data pins. The ports can operate at up to 166 MHz and act as either a receiver or a transmitter. The ports can be used to interface gluelessly to other ADSP-21469 processors that also have the link port pins brought out.

The EZ-Board enables access to link ports 0 and 1 via connectors P12 and J3, respectively. Two ADSP-21469 EZ-Boards can mate gluelessly via the link port connectors. The processors can communicate via the link ports, all while performing independent tasks on each of the EZ-Boards. To loopback the link port connectors on one EZ-Board or connect three or more EZ-Boards, obtain a standard, off the shelf connector from Samtec. For more information, see [“Link Port 0 Connector \(P12\)” on page 2-30](#).

The EZ-Board design enables a multi-processor JTAG session using connectors J3 and P12. Two or more EZ-Boards can connect via the link ports and JTAG interfaces and run in a single multi-processor debug session. For more information, see [“JTAG Interface” on page 1-23](#).

By default, the EZ-Board boots from the 8-bit flash parallel memory. Link port 0 can be selected as the boot source by setting the boot mode select switch (SW4) to position 4. See [“Boot Mode Select Switch \(SW4\)” on page 2-10](#).

Temperature Sensor Interface

Two external pins (THD_P and THD_M) of the processor are connected to an internal thermal diode. The EZ-Board uses ON Semiconductor’s ADM1032 digital thermometer and under/over temperature alarm to monitor the processor’s temperature as well as the thermal diode that exists inside the ADM1032 device. The device uses the I²C bus, DPI pins, and flag pins to communicate to the processor. The following DPI and flag pins are used by the processor and temperature sensing monitor.

- DPI pin 8 (DPI_P8) as the serial clock signal (SCK)
- DPI pin 7 (DPI_P7) as the serial data signal (SDA)
- Flag 3 as the IRQ (not used by default)
- Flag 0 as the thermal limit (not used by default)

S/PDIF Interface

The two DPI pins are required; the pins are connected to the temperature sensing monitor via a switch (SW3) and can be shut off if the pins are used on the expansion II interface. The thermal limit flag is connected to a LED (LED11) for a visual alarm if the limit is exceeded. The thermal limit flag and ADM1032 IRQ connect to the flag pins of the processor, but are nonessential for communications. Consequently, SW13 has both flag pins defaulted in the OFF position.

See [“DPI \[1–8\] Enable Switch \(SW3\)” on page 2-9](#) and [“Asynchronous Control Enable Switch \(SW13\)” on page 2-13](#) for more information.

Example programs are included in the EZ-Board installation directory to demonstrate sensor operations.

S/PDIF Interface

The ADSP-21469 processor has a built-in S/PDIF transmitter and receiver for digital audio applications. The EZ-Board supports the S/PDIF interface and brings out both the transmitter and receiver via RCA connectors J4 and J5, respectively. The S/PDIF's in and out pins are connected by DAI pins via switches SW1 and SW7:

- DAI pin 1 (DAI_P1) as SPDIF_OUT
- DAI pin 18 (DPI_P18) as SPDIF_IN

SW1 and SW7 can be turned off to disconnect the DAI pins from the RCA connectors if the pins are used on the expansion II interface. See [“DAI \[1–8\] Enable Switch \(SW1\)” on page 2-8](#) and [“DAI \[17–20\] Enable Switch \(SW7\)” on page 2-11](#) for more information.

Audio Interface

The AD1939 device is a high-performance, single-chip codec featuring eight digital-to-analog converters (DACs) for audio output and four analog-to-digital converters (ADCs) for audio input. This translates to four stereo channels of audio out and two stereo channels of audio in.

The codec can input and output data at a sample rate of up to 192 kHz on all channels.

The analog audio channels are available via single-ended RCA connectors (J4 and J5) or differential DB25 connectors (P8 and P9). By default, the EZ-Board is shipped with the RCA connectors used by the AD1939 codec for audio in and out. To use the differential connectors, change DIP switches SW15-18. A standard, off the shelf DB25 connector to XLR cables is required to operate in this mode.

For more information, see [“Audio In1 Left Selection Switch \(SW15\)” on page 2-14](#) through [“Audio In2 Left Selection Switch \(SW18\)” on page 2-16](#), and [“ADSP-21469 EZ-Board Schematic” on page B-1](#).

The processor interfaces with the codec via the DAI and DPI pins. The DAI pins can be configured to transfer serial data from the codec in Time-Division Multiplexing (TDM) or Integrated Interchip Sound (I²S) mode. See [“DAI Interface” on page 2-3](#) for more information about the AD1939 connection to the DAI. The DPI interface pins can be configured to use the SPI interface of the processor to set up the codec’s control registers. See [“DPI Interface” on page 2-4](#) for more information about the AD1939 connection to the DPI.

The master input clock (MCLK) of the codec is generated by the on-board 12.288 MHz oscillator. The internal PLL of the codec is used to generate varying sample rates. The codec can be set up for 48 KHz, 96 KHz, or 192 KHz frequencies. The codec can run at these frequencies in both TDM and I²S modes with all ADCs inputs and DACs outputs. To run 192 KHz with all ADCs and DACs in TDM mode, the codec must run in dual-line TDM mode.

UART Interface

For information on how to configure the multi-channel codec, refer to the product datasheet at www.analog.com/AD1939.

The EZ-Board is connected to the AD1939 codec in master mode. The internal PLL drives the ABCLK and ALRCLK clock signals out. Both clocks are driven back to the codec's DBCLK and DLRCLK pins via the R257 and R258 resistors. The ABCLK and ALRCLK clocks that are driven by the codec also connect to the processor's serial ports via the DAI pins. Resistors R262 and R263 are used to feed the bit clock and frame sync signals of the processor's serial ports. Connecting the codec in this manner enables a flexible audio sample rate and allows the processor to run at the maximum core frequency.

The audio interface also has a 3.5 mm connector (J8) for headphones. The headphones share the output with the external DAC5 and DAC6 circuits of the analog audio interface. Switch SW23 must be enabled for the headphones. A volume control potentiometer (R493) is used to increase or decrease the headphone's volume. [For more information, see “Headphone Enable Switch \(SW23\)” on page 2-19.](#)

Example programs are included in the EZ-Board installation directory to demonstrate how to configure and use the board's analog audio interface.

The DAI and DPI pins going to the AD1939 device can be disabled, then used on the expansion II interface. Refer to [“DAI Interface” on page 2-3](#) and [“DPI Interface” on page 2-4](#) for more information about the DAI and DPI switches.

UART Interface

The ADSP-21469 processor features a built-in universal asynchronous receiver and transmitter (UART). The UART interface supports full RS-232 functionality via the Analog Devices 3.3V ADM3202 line driver and receiver (U42). The UART signals are available on the EZ-Board via DIP switch SW14. The UART signals are routed through a DIP switch, can

be disconnected from the respective DPI interface, and used on the expansion II interface. The following DPI pins are used for the RS-232 interface.

- DPI pin 9 (DPI_P9) as UART_TX
- DPI pin 10 (DPI_P10) as UART_RX
- DPI pin 11 (DPI_P11) as UART_RTS
- DPI pin 12 (DPI_P12) as UART_CTS

Example programs are included in the EZ-Board installation directory to demonstrate UART and RS-232 operations.

For more information about the UART interface, refer to the *ADSP-214xx SHARC Processor Hardware Reference*.

LEDs and Push Buttons

The EZ-Board has eight general-purpose user LEDs connected directly to the processor, one LED connected to the temperature sensing monitor (ADM1032), one EZ-Board power LED, and one board reset LED. The EZ-board also has five push buttons: four general-purpose push buttons, connected directly to the processor, and one push button for a board reset.

[Table 1-3](#) summarizes the LED connections to the processor. To use the LEDs connected to the DAI or DPI interface, configure the respective registers of the processor. For more information, refer to the *ADSP-214xx SHARC Processor Hardware Reference*.

LEDs and Push Buttons

Table 1-3. LED Connections

| LED Reference Designator | Processor Pin | Connected via Switch |
|--------------------------|---------------|----------------------|
| LED1 | DPI_P6 | SW3.6 |
| LED2 | DPI_P13 | SW14.5 |
| LED3 | DPI_P14 | SW14.6 |
| LED4 | DAI_P3 | SW1.3 |
| LED5 | DAI_P4 | SW1.4 |
| LED6 | DAI_P15 | SW2.7 |
| LED7 | DAI_P16 | SW2.8 |
| LED8 | DAI_P17 | SW7.1 |

Two general-purpose push buttons are attached to the flag pins of the processor, while the other two are attached to the DAI pins. All of the push buttons and LEDs connect to the processor through DIP switches. The DIP switches can disconnect the processor pins, which, in turn, connect to the push buttons and LEDs. See the respective switch section in [“ADSP-21469 EZ-Board Hardware Reference” on page 2-1](#).

The state of the push buttons, connected to the flag pins, can be determined by reading the `FLAG` register. The push buttons connected to the DAI pins must be configured as interrupts. It is necessary to set up an interrupt routine to determine each pin's state. [Table 1-4](#) shows the push button and processor connections.

Table 1-4. Push Button Connections

| PB Reference Designator | Processor Pin | Connected via Switch |
|-------------------------|----------------|----------------------|
| SW8 (PB1) | FLAG1/IRQ1 | SW13.4 |
| SW9 (PB2) | FLAG2/IRQ2/MS2 | SW13.5 |
| SW10 (PB3) | DAI_P19 | SW7.3 |
| SW11 (PB4) | DAI_P20 | SW7.4 |

An example program is included in the ADSP-21469 installation directory to demonstrate functionality of the LEDs and push buttons.

JTAG Interface

The JTAG connector (P1) allows the standalone debug agent module to connect a debug session to the ADSP-21469 processor. The debug agent operates only when the external 5V wall adaptor (P16) is used.

The standalone debug agent can be replaced by an external emulator, such as the Analog Devices high-performance USB-based emulator. Be careful not to damage the connectors when removing the debug agent. The emulator connects to P1 on the back side of the board; see [“CCES Install and Session Startup” on page 1-5](#) or [“VisualDSP++ Install and Session Startup” on page 1-9](#) for more information.

The ADSP-21469 EZ-Board can be set up as a single- or multi-processor system. By default, the board is set up in single-processor mode. In single-processor mode, create a session based on a standalone debug agent or an external emulator. To use the EZ-Board in multi-processor mode, install an external emulator. Only one external emulator is required for the main EZ-Board; other EZ-Boards in the JTAG chain do not require an emulator. In this mode, create a platform based on the number of JTAG devices in the JTAG chain using the VisualDSP++ Configurator. Then create a session in VisualDSP++ based on the newly created platform. For multiprocessor mode under CCES, create a platform based on

Land Grid Array

the number of JTAG devices in the JTAG chain using the Target Configurator. Then create a Debug Configuration in CCES based on the newly created platform.

For a dual ADSP-21469 EZ-Board session, connect two EZ-Boards via connectors J3 and P12. Flip one of the two EZ-Boards by 180 degrees to allow the boards to mate. To switch between single- and multi-processor modes, use DIP switches SW19-22. [For more information, see “JTAG Switches \(SW19–22\)” on page 2-17.](#)

For three or more ADSP-21469 EZ-Board sessions, connect each of the EZ-Board with the link port cables. The cables connect the link ports and JTAG pins of each EZ-Board. By using the link port cables, you put the EZ-Board in a JTAG serial chain and the ADSP-21469 processors' link ports in a ring. For three EZ-Boards, three link port cables are required. Similarly, for four EZ-Boards, four link port cables are required. Note that each respective EZ-board also requires its own power supply.

Part numbers for Samtec standard, off the shelf link port cables can be found in [“Link Port 0 Connector \(P12\)” on page 2-30.](#)

For more information about emulators, go to:
<http://www.analog.com/processors/tools/sharc>.

Land Grid Array

The ADSP-21469 EZ-Board has provisions for probing every DAI pin, DPI pin, and the asynchronous memory interface pins of the processor on connectors P5-7. The connector locations are designed to be used in conjunction with a Tektronix DMAX logic analyzer connector, but can be probed with any oscilloscope or logic analyzer. For pinout information, refer to [“ADSP-21469 EZ-Board Schematic” on page B-1.](#)

For more information on the Tektronix DMAX logic analyzer interface, go to the Tektronix Web site.

Expansion Interface II

The expansion interface II allows an Analog Devices EZ-Extender[®] or a custom-design daughter board to be tested across various hardware platforms with identical expansion interfaces.

The expansion interface II implemented on the ADSP-21469 EZ-Board consists of two connectors: a 0.1 in. shrouded header (P2) and a Samtec QMS series header (J1). The connectors contain a majority of the ADSP-21469 processor's signals.

 DDR2 interface is not brought out to the expansion interface because the interface layout and net length is critical.

For pinout information, go to “[ADSP-21469 EZ-Board Schematic](#)” on [page B-1](#). The mechanical dimensions of the expansion connectors can be obtained by contacting [Technical Support](#).

For more information about daughter boards, visit the Analog Devices Web site at:

<http://www.analog.com/processors/tools/sharc>.

Limits to current and interface speed must be taken into consideration when using the expansion interface II. Current for the expansion interface II is sourced from the EZ-Board; therefore, the current should be limited to 1A for 5V and 500 mA for the 3.3V planes. If more current is required, then a separate power connector and a regulator must be designed on a daughter card. Additional circuitry can add extra loading to signals, decreasing their maximum effective speed.

 Analog Devices does not support and is not responsible for the effects of additional circuitry.

Power Measurements

Several locations are provided for measuring the current draw from various power planes. Precision 0.05 ohm shunt resistors are available on the VDDINT, VDDEXT, and VDD_DDR2 voltage domains. For current draw measurements, the associated jumper on connector P13–15 must be removed. Once the jumper is removed, voltage across the resistor can be measured using an oscilloscope. Once voltage is measured, current can be calculated by dividing the voltage by 0.05. For the highest accuracy, a differential probe should be used for measuring voltage across the resistor.

For more information, see [“VDD_DDR2 Power Connector \(P13\)” on page 2-30](#), [“VDDINT Power Connector \(P14\)” on page 2-30](#), and [“VDDEXT Power Connector \(P15\)” on page 2-30](#).

Power-On-Self Test

The power-on-self-test program (POST) tests all EZ-Board peripherals and validates functionality as well as connectivity to the processor. Once assembled, each EZ-Board is fully tested for an extended period of time with a POST. All EZ-Boards are shipped with the POST preloaded into one of its on-board flash memories. The POST is executed by resetting the board and pressing the proper push button(s). The POST also can be used as a reference in custom software designs or hardware troubleshooting. Note that the source code for the POST program is included in the installation directory along with the readme file, which describes how the EZ-Board is configured to run a POST.



The POST program is only available when using VisualDSP++.

Example Programs

Example programs are provided with the ADSP-21469 EZ-KIT Lite to demonstrate various capabilities of the product. The programs are included in the product installation kit and can be found in the `Examples` folder of the installation. Refer to a readme file provided with each example for more information.

CCES users are encouraged to use the example browser to find examples included with the EZ-KIT Lite Board Support Package.

Board Design Database

A `.zip` file containing all of the electronic information required for the design, layout, fabrication and assembly of the product is available for download from the Analog Devices board design database at:
<http://www.analog.com/sharc-board-design-database>.

Board Design Database

2 ADSP-21469 EZ-BOARD HARDWARE REFERENCE

This chapter describes the hardware design of the ADSP-21469 EZ-Board board.

The following topics are covered.

- [“System Architecture” on page 2-2](#)
Describes the ADSP-21469 EZ-Board configuration and explains how the board components interface with the processor.
- [“Flags and Memory Selects” on page 2-5](#)
Shows the locations and describes the DAI pins, DPI pins, general purpose flags, and asynchronous memory select lines.
- [“Push Button and Switch Settings” on page 2-7](#)
Shows the locations and describes the push buttons and switches.
- [“Jumpers” on page 2-20](#)
Shows the locations and describes the configuration jumpers.
- [“LEDs” on page 2-22](#)
Shows the locations and describes the LEDs.
- [“Connectors” on page 2-25](#)
Shows the locations and provides part numbers for the on-board connectors. In addition, the manufacturer and part number information is provided for the mating parts.

System Architecture

This section describes the processor's configuration on the EZ-Board (Figure 2-1).

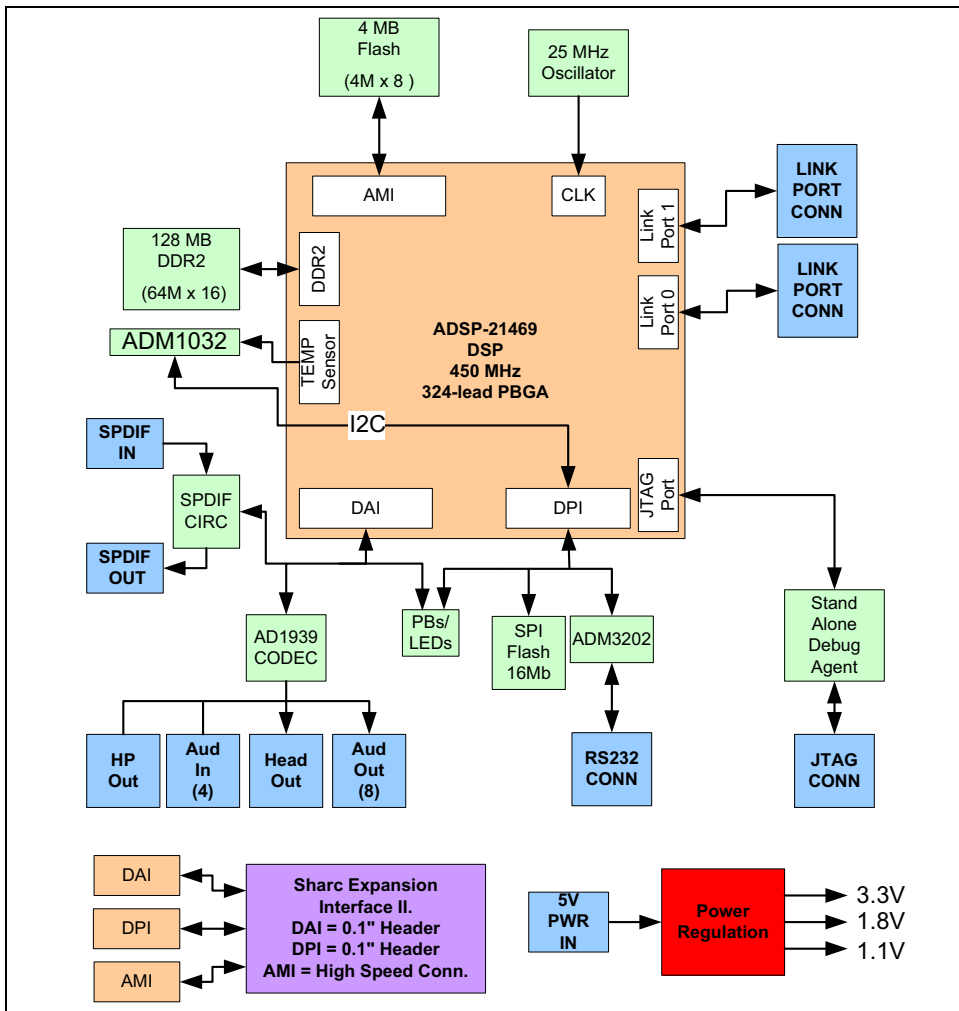

Figure 2-1. System Architecture

The EZ-Board is designed to demonstrate the ADSP-21469 SHARC processor capabilities. The processor has an I/O voltage of 3.3V. The core voltage of the processor is 1.1V, and the double data rate (DDR2) voltage is 1.8V.

The input clock is 25 MHz. The default boot mode of the processor is external parallel flash boot. See [“Boot Mode Select Switch \(SW4\)”](#) on [page 2-10](#) for information on how to change the default boot mode.

DAI Interface

The digital application interface (DAI) pins are connected to the signal routing unit (SRU) of the processor. The SRU is a flexible routing system providing a large system of signal flows within the processor. The SRU allows you to route the DAI pins to different internal peripherals in various combinations.

The DAI connects various peripherals on the EZ-Board. [Table 2-1](#) shows the DAI pin names, associated peripheral and net names, switch designators through which the pins connect to the peripherals, and default switch settings.

Table 2-1. DAI Connections

| DAI Pin | Peripheral | Peripheral Net | Connected via Switch | Switch Setting (Default) |
|---------|------------|----------------|----------------------|--------------------------|
| DAI_P1 | S/PDIF | SPDIF_OUT | SW1.1 | ON |
| DAI_P2 | AD1939 | SOFT_RESET | SW1.2 | ON |
| DAI_P3 | LEDs | LED4 | SW1.3 | ON |
| DAI_P4 | LEDs | LED5 | SW1.4 | ON |
| DAI_P5 | AD1939 | ASDATA1 | SW1.5 | ON |
| DAI_P6 | AD1939 | ASDATA2 | SW1.6 | ON |
| DAI_P7 | AD1939 | ABCLK | SW1.7 | ON |
| DAI_P8 | AD1939 | ALRCLK | SW1.8 | ON |

System Architecture

Table 2-1. DAI Connections (Cont'd)

| DAI Pin | Peripheral | Peripheral Net | Connected via Switch | Switch Setting (Default) |
|---------|--------------|----------------|----------------------|--------------------------|
| DAI_P9 | AD1939 | DSDATA4 | SW2.1 | ON |
| DAI_P10 | AD1939 | DSDATA3 | SW2.2 | ON |
| DAI_P11 | AD1939 | DSDATA2 | SW2.3 | ON |
| DAI_P12 | AD1939 | DSDATA1 | SW2.4 | ON |
| DAI_P13 | AD1939 | DBCLK | SW2.5 | ON |
| DAI_P14 | AD1939 | DLRCLK | SW2.6 | ON |
| DAI_P15 | LEDs | LED6 | SW2.7 | ON |
| DAI_P16 | LEDs | LED7 | SW2.8 | ON |
| DAI_P17 | LEDs | LED8 | SW7.1 | ON |
| DAI_P18 | S/PDIF | SPDIF_IN | SW7.2 | ON |
| DAI_P19 | Push buttons | PB3 | SW7.3 | ON |
| DAI_P20 | Push buttons | PB4 | SW7.4 | ON |

To use the DAI on the expansion II interface, disable any signal driving a DAI pin with the associated switch. The pinout of the expansion connectors can be found in [“ADSP-21469 EZ-Board Schematic”](#) on page B-1.

DPI Interface

The digital peripheral interface (DPI) pins are connected to a second signal routing unit of the processor (SRU2). The SRU2 unit, similar to the SRU, is a flexible routing system providing a large system of signal flows within the processor. The SRU2 allows you to route the DPI pins to different internal peripherals in various combinations.

The DPI connects various peripherals on the EZ-Board. [Table 2-2](#) shows the DPI pin names, associated peripheral and net names, switch designators through which the pins connect to the peripherals, and default switch settings.

Table 2-2. DPI Connections

| DPI Pin | Peripheral | Peripheral Net | Connected via Switch | Switch Setting (Default) |
|---------|-------------------|----------------|----------------------|--------------------------|
| DPI_P1 | SPI memory AD1939 | SPI_MOSI | SW3.1 | ON |
| DPI_P2 | SPI memory AD1939 | SPI_MISO | SW3.2 | ON |
| DPI_P3 | SPI memory AD1939 | SPI_CLK | SW3.3 | ON |
| DPI_P4 | AD1939 | AD1939_CS | SW3.4 | ON |
| DPI_P5 | SPI memory | SPI_CS | SW3.5 | ON |
| DPI_P6 | LEDs | LED1 | SW3.6 | ON |
| DPI_P7 | Temp sensor | TEMP_SDA | SW3.7 | ON |
| DPI_P8 | Temp sensor | TEMP_SCK | SW3.8 | ON |
| DPI_P9 | UART | UART_TX | SW14.1 | ON |
| DPI_P10 | UART | UART_RX | SW14.2 | ON |
| DPI_P11 | UART | UART_RTS | SW14.3 | OFF |
| DPI_P12 | UART | UART_CTS | SW14.4 | OFF |
| DPI_P13 | LEDs | LED2 | SW14.5 | ON |
| DPI_P14 | LEDs | LED3 | SW14.6 | ON |

To use the DPI on the expansion II interface, disable any signal driving a DPI pin with the associated switch. The pinout of the expansion connectors can be found in [“ADSP-21469 EZ-Board Schematic”](#) on page B-1.

Flags and Memory Selects

The processor has four asynchronous memory selects, four flag pins, three interrupt request pins, and one timer expired pin. All flag/memory pins are multi-functional and depend on the ADSP-21469 processor setup.

[Table 2-3](#) shows the pin names, corresponding peripheral and net names,

Flags and Memory Selects

switch designators through which the pins connect to the peripherals, and default switch settings.

To use the flags or memory selects on the expansion II interface, disable any signal driving a flag or memory pin with the associated switch. The pinout of the expansion connectors can be found in [“ADSP-21469 EZ-Board Schematic”](#) on page B-1.

Table 2-3. Flags and Memory Select Connections

| Flag/Memory Pin | Peripheral | Peripheral Net | Connected via Switch | Switch Setting (Default) |
|------------------|-----------------------|----------------|----------------------|--------------------------|
| MS0 | Parallel flash memory | FLASH_CS | SW13.1 | OFF |
| MS1 | Parallel flash memory | FLASH_CS | SW13.2 | ON |
| FLAG0/IRQ0 | Temp sensor | THERMAL_LIMIT | SW13.3 | OFF |
| FLAG1/IRQ1 | Push buttons | PB1 | SW13.4 | ON |
| FLAG2/IRQ2/MS2 | Push buttons | PB2 | SW13.5 | ON |
| FLAG3/TIMEXP/MS3 | Temp sensor | TEMP_IRQ | SW13.6 | OFF |

Push Button and Switch Settings

This section describes operation of the push buttons and switches. The push button and switch locations are shown in [Figure 2-2](#).

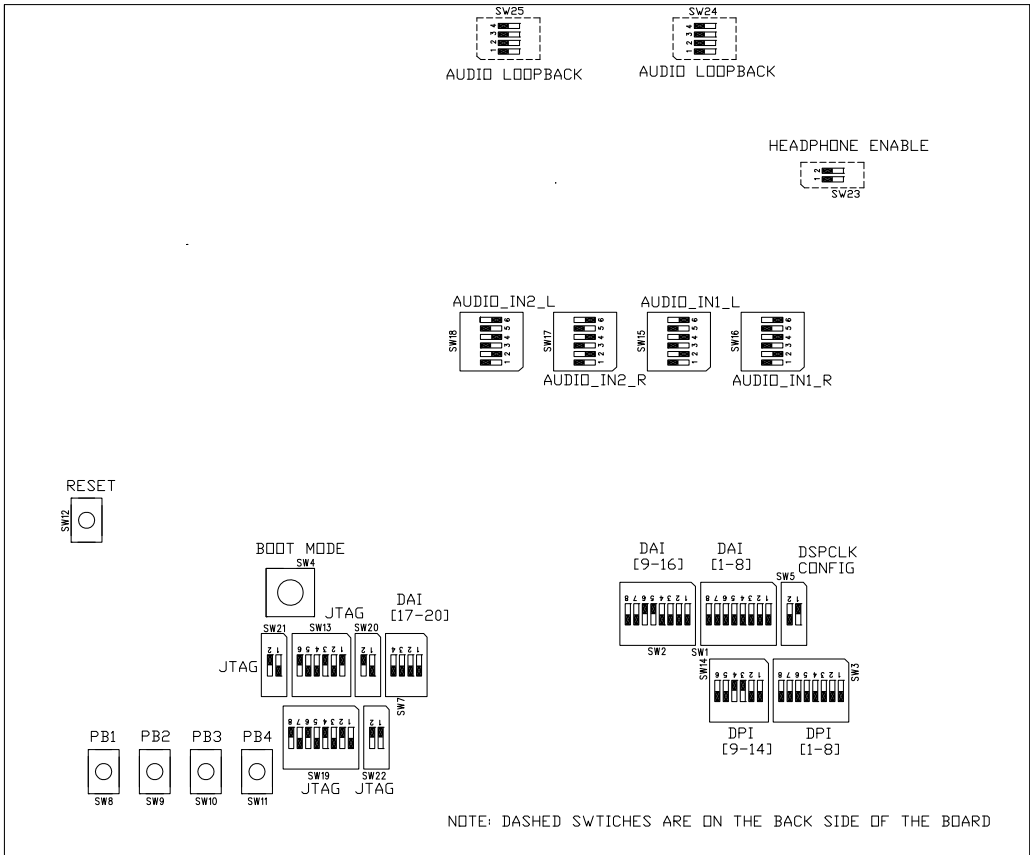

Figure 2-2. Push Button and Switch Locations

Push Button and Switch Settings

DAI [1–8] Enable Switch (SW1)

The DAI [1–8] enable switch (SW1) disconnects the DAI pins one through eight on the processor from the associated peripherals on the EZ-Board and allows the DAI signals to be used on the expansion II interface; see [Table 2-4](#).

Table 2-4. DAI [1–8] Enable Switch (SW1)

| SW1 Position | DAI Pin | Peripheral | Peripheral Net | Switch Setting (Default) |
|--------------|---------|------------|----------------|--------------------------|
| SW1.1 | DAI_P1 | S/PDIF | SPDIF_OUT | ON |
| SW1.2 | DAI_P2 | AD1939 | SOFT_RESET | ON |
| SW1.3 | DAI_P3 | LEDs | LED4 | ON |
| SW1.4 | DAI_P4 | LEDs | LED5 | ON |
| SW1.5 | DAI_P5 | AD1939 | ASDATA1 | ON |
| SW1.6 | DAI_P6 | AD1939 | ASDATA2 | ON |
| SW1.7 | DAI_P7 | AD1939 | ABCLK | ON |
| SW1.8 | DAI_P8 | AD1939 | ALRCLK | ON |

DAI [9–16] Enable Switch (SW2)

The DAI [9–16] enable switch (SW2) disconnects the DAI pins nine through 16 on the processor from the associated peripherals on the EZ-Board and allows the DAI signals to be used on the expansion II interface; see [Table 2-5](#).

Table 2-5. DAI [9–16] Enable Switch (SW2)

| SW2 Position | DAI Pin | Peripheral | Peripheral Net | Switch Setting (Default) |
|--------------|---------|------------|----------------|--------------------------|
| SW2.1 | DAI_P9 | AD1939 | DSDATA4 | ON |
| SW2.2 | DAI_P10 | AD1939 | DSDATA3 | ON |
| SW2.3 | DAI_P11 | AD1939 | DSDATA2 | ON |
| SW2.4 | DAI_P12 | AD1939 | DSDATA1 | ON |
| SW2.5 | DAI_P13 | AD1939 | DBCLK | OFF |
| SW2.6 | DAI_P14 | AD1939 | DLRCLK | OFF |
| SW2.7 | DAI_P15 | LEDs | LED6 | ON |
| SW2.8 | DAI_P16 | LEDs | LED7 | ON |

DPI [1–8] Enable Switch (SW3)

The DPI [1–8] enable switch (SW3) disconnects the DPI pins one through eight on the processor from the associated peripherals on the EZ-Board and allows the DPI signals to be used on the expansion II interface; see [Table 2-6](#).

Table 2-6. DPI [1–8] Enable Switch (SW3)

| SW3 Position | DPI Pin | Peripheral | Peripheral Net | Switch Setting (Default) |
|--------------|---------|----------------------|----------------|--------------------------|
| SW3.1 | DPI_P1 | SPI memory AD1939 | SPI_MOSI | ON |
| SW3.2 | DPI_P2 | SPI memory AD1939 | SPI_MISO | ON |
| SW3.3 | DPI_P3 | SPI memory AD1939 | SPI_CLK | ON |
| SW3.4 | DPI_P4 | AD1939 | AD1939_CS | ON |
| SW3.5 | DPI_P5 | SPI memory | SPI_CS | ON |
| SW3.6 | DPI_P6 | LEDs | LED1 | ON |

Push Button and Switch Settings

Table 2-6. DPI [1–8] Enable Switch (SW3) (Cont'd)

| SW3 Position | DPI Pin | Peripheral | Peripheral Net | Switch Setting (Default) |
|--------------|---------|-------------|----------------|--------------------------|
| SW3.7 | DPI_P7 | Temp sensor | TEMP_SDA | ON |
| SW3.8 | DPI_P8 | Temp sensor | TEMP_SCK | ON |

Boot Mode Select Switch (SW4)

The boot mode select switch (SW4) determines the boot mode of the processor. [Table 2-7](#) shows the available boot mode settings. By default, the processor boots from the on-board parallel flash memory.

The selected position of SW4 is marked by the notch down the entire rotating portion of the switch, not the small arrow.

Table 2-7. Boot Mode Select Switch (SW4)

| SW4 Position | Processor Boot Mode |
|--------------|---|
| 0 | SPI slave boot |
| 1 | Boot from SPI flash memory (SPI master boot) |
| 2 | Boot from 8 external parallel flash memory (default) |
| 3 | Reserved |
| 4 | Link port 0 boot |
| 5 | Reserved |
| 6 | Reserved |
| 7 | Reserved |

DSP Clock Configuration Switch (SW5)

The clock configuration switch (SW5) controls the core frequency of the processor at power up. The core to clock-in ratio is multiplied by the 25 MHz oscillator (U41) to produce the power up core frequency.

[Table 2-8](#) shows the switch settings.

The core clock frequency can be increased or decreased via software by writing to the PMCTL register. For more information on changing the core clock frequency and other settings, refer to the *ADSP-214xx SHARC Processor Hardware Reference*.

Table 2-8. Processor Clock Configuration Switch (SW5)

| Position 1 CLKCFG0 | Position 2 CLKCFG0 | Clock Ratio Core: Clock |
|-----------------------|-----------------------|----------------------------|
| ON | ON | Reserved |
| ON | OFF | 32:1 |
| OFF | ON | 16:1 (default) |
| OFF | OFF | 6:1 |

DAI [17–20] Enable Switch (SW7)

The DAI [17–20] enable switch (SW7) disconnects the DAI pins 17 through 20 on the processor from the associated peripherals on the EZ-Board and allows the DAI signals to be used on the expansion II interface; see [Table 2-9](#).

Table 2-9. DAI [17–20] Enable Switch (SW7)

| SW7 Position | DAI Pin | Peripheral | Peripheral Net | Switch Setting (Default) |
|--------------|---------|------------|----------------|-----------------------------|
| SW7.1 | DAI_P17 | LEDs | LED8 | ON |
| SW7.2 | DAI_P18 | S/PDIF | SPDIF_IN | ON |

Push Button and Switch Settings

Table 2-9. DAI [17–20] Enable Switch (SW7) (Cont'd)

| SW7 Position | DAI Pin | Peripheral | Peripheral Net | Switch Setting (Default) |
|--------------|---------|--------------|----------------|--------------------------|
| SW7.3 | DAI_P19 | Push buttons | PB3 | ON |
| SW7.4 | DAI_P20 | Push buttons | PB4 | ON |

Programmable Flag Push Buttons (SW8–11)

Four momentary push buttons (SW8-11) are provided for general-purpose user input. The buttons are connected to the GPIO pins of the processor. The push buttons are active high and, when pressed, send a high (1) to the processor. Switches SW7 and SW13 disconnect the push buttons from the responding signals. Refer to [“DAI \[17–20\] Enable Switch \(SW7\)” on page 2-11](#) and [“Asynchronous Control Enable Switch \(SW13\)” on page 2-13](#) for more information.

Reset Push Button (SW12)

The reset push button (SW12) resets the following ICs:

- ADSP-21469 processor (U1)
- AD1939 audio codec (U45)
- Parallel flash memory (U18)

The reset also is linked to the expansion II interface; any daughter card connected to the expansion interface that requires a reset can use SW12.

The reset push button does not reset the standalone debug agent once the debug agent is connected to a personal computer (PC). After communication between the debug agent and PC is initialized, pushing a reset button does not reset the USB chip on the debug agent. The only way to reset the USB chip on the debug agent is to power down the EZ-Board.

Asynchronous Control Enable Switch (SW13)

The asynchronous control enable switch (SW13) disconnects the control pins of the processor from the associated peripherals on the EZ-Board and allows the respective control signals to be used on the expansion II interface; see [Table 2-10](#).

Table 2-10. Asynchronous Control Enable Switch (SW13)

| SW13 Position | Processor Pin | Peripheral | Peripheral Net | Switch Setting (Default) |
|---------------|------------------|-----------------------|----------------|--------------------------|
| SW13.1 | MS0 | Parallel flash memory | FLASH_CS | OFF |
| SW13.2 | MS1 | Parallel flash memory | FLASH_CS | ON |
| SW13.3 | FLAG0/IRQ0 | Temp sensor | THERMAL LIMIT | OFF |
| SW13.4 | FLAG1/IRQ1 | Push buttons | PB1 | ON |
| SW13.5 | FLAG2/IRQ2/MS2 | Push buttons | PB2 | ON |
| SW13.6 | FLAG3/TIMEXP/MS3 | Temp sensor | TEMP_IRQ | OFF |

DPI [9–14] Enable Switch (SW14)

The DPI [9–14] enable switch (SW14) disconnects the DPI pins nine through 14 on the processors from the associated peripherals on the EZ-Board and allows the DPI signals to be used on the expansion II interface; see [Table 2-11](#).

Table 2-11. DPI [9–14] Enable Switch (SW14)

| SW14 Position | DPI Pin | Peripheral | Peripheral Net | Switch Setting (Default) |
|---------------|---------|------------|----------------|--------------------------|
| SW14.1 | DPI_P9 | UART | UART_TX | ON |
| SW14.2 | DPI_P10 | UART | UART_RX | ON |

Push Button and Switch Settings

Table 2-11. DPI [9–14] Enable Switch (SW14) (Cont'd)

| SW14 Position | DPI Pin | Peripheral | Peripheral Net | Switch Setting (Default) |
|---------------|---------|------------|----------------|--------------------------|
| SW14.3 | DPI_P11 | UART | UART_RTS | OFF |
| SW14.4 | DPI_P12 | UART | UART_CTS | OFF |
| SW14.5 | DPI_P13 | LEDs | LED2 | ON |
| SW14.6 | DPI_P14 | LEDs | LED3 | ON |

Audio In1 Left Selection Switch (SW15)

The audio selection switch (SW15) connects the left channel of the In1 line, connected to the AD1939's ADC1 circuit, to either the single-ended RCA connectors or the differential DB25 connector. By default, SW15 is set up to use the RCA connectors. To use the standard, off the shelf DB25 connector to XLR cables, change the switch to the differential setting; see [Table 2-12](#). For more information, see “[Differential In/Out Connectors \(P8–9\)](#)” on [page 2-29](#).

Table 2-12. Audio In1 Left Selection Switch (SW15)

| SW15 Position | Single-Ended RCA IN (Default) | Differential DB25 IN (P8) |
|---------------|-------------------------------|---------------------------|
| SW15.1 | ON | OFF |
| SW15.2 | OFF | ON |
| SW15.3 | ON | OFF |
| SW15.4 | OFF | ON |
| SW15.5 | ON | OFF |
| SW15.6 | OFF | ON |

Audio In1 Right Selection Switch (SW16)

The audio selection switch (SW16) connects the right channel of the In1 line, connected to the AD1939's ADC2 circuit, to either the single-ended RCA connectors or the differential DB25 connector. By default, the switch is set up to use the RCA connectors for audio in. To use the standard, off the shelf DB25 connector to XLR cables, change the switch to the differential setting; see [Table 2-13](#). For more information, see “[Differential In/Out Connectors \(P8–9\)](#)” on page 2-29.

Table 2-13. Audio In1 Right Selection Switch (SW16)

| SW16 Position | Single-Ended RCA IN (Default) | Differential DB25 IN (P8) |
|---------------|-------------------------------|---------------------------|
| SW16.1 | ON | OFF |
| SW16.2 | OFF | ON |
| SW16.3 | ON | OFF |
| SW16.4 | OFF | ON |
| SW16.5 | ON | OFF |
| SW16.6 | OFF | ON |

Audio In2 Right Selection Switch (SW17)

The audio selection switch (SW17) connects the right channel of the In2 line, connected to the AD1939's ADC4 circuit, to either the single-ended RCA connectors or the differential DB25 connector. By default, the switch is set up to use the RCA connectors for audio in. To use the standard, off the shelf DB25 connector to XLR cables, change the switch to the differential setting; see [Table 2-14](#). For more information, see “[Differential In/Out Connectors \(P8–9\)](#)” on page 2-29.

Push Button and Switch Settings

Table 2-14. Audio In2 Right Selection Switch (SW17)

| SW17 Position | Single Ended Use RCA IN (Default) | Differential DB25 IN (P8) |
|---------------|-----------------------------------|---------------------------|
| SW17.1 | ON | OFF |
| SW17.2 | OFF | ON |
| SW17.3 | ON | OFF |
| SW17.4 | OFF | ON |
| SW17.5 | ON | OFF |
| SW17.6 | OFF | ON |

Audio In2 Left Selection Switch (SW18)

The audio selection switch (SW18) connects the left channel of the In2 line, connected to the AD1939's ADC3 circuit, to either the single-ended RCA connectors or the differential DB25 connector. By default, the switch is set up to use the RCA connectors for audio in. To use the standard, off the shelf DB25 connector to XLR cables, change the switch to the differential setting; see [Table 2-15](#). For more information, see “[Differential In/Out Connectors \(P8–9\)](#)” on page 2-29.

Table 2-15. Audio In2 Left Selection Switch (SW18)

| SW18 Position | Single Ended RCA IN (Default) | Differential DB25 IN (P8) |
|---------------|-------------------------------|---------------------------|
| SW18.1 | ON | OFF |
| SW18.2 | OFF | ON |
| SW18.3 | ON | OFF |
| SW18.4 | OFF | ON |
| SW18.5 | ON | OFF |
| SW18.6 | OFF | ON |

JTAG Switches (SW19–22)

The JTAG switches (SW19–22) select between a single-processor (one EZ-Board) and multi-processor (more than one EZ-Board) configurations. By default, the four DIP switches are set up for a single EZ-Board configuration; see [Table 2-16](#).

The default configuration applies to either a debug agent or an external emulator, such as the Analog Devices high-performance USB-based emulator (HP-USB ICE for short). To use an external emulator and multiple EZ-Boards simultaneously in one multi-processor session, set up the boards as shown in [Table 2-17](#). Attach the boards to each other via connectors J3 and P12. For two EZ-Boards, no external cables are required. For three or more EZ-Boards, obtain Samtec link port cables described in “[Link Port 1 Connector \(J3\)](#)” on page 2-26 and “[Link Port 0 Connector \(P12\)](#)” on page 2-30.

Table 2-16. Single-Processor Configuration

| Switch Position | Single EZ-Board Use (Default) |
|-----------------|-------------------------------|
| SW19.1 | ON |
| SW19.2 | OFF |
| SW19.3 | ON |
| SW19.4 | OFF |
| SW19.5 | ON |
| SW19.6 | OFF |
| SW19.7 | ON |
| SW19.8 | OFF |
| SW20.1 | ON |
| SW20.2 | OFF |
| SW21.1 | ON |
| SW21.2 | OFF |

Push Button and Switch Settings

Table 2-16. Single-Processor Configuration (Cont'd)

| Switch Position | Single EZ-Board Use (Default) |
|-----------------|-------------------------------|
| SW22.1 | OFF |
| SW22.2 | OFF |

Table 2-17. Multiple-Processor Configuration

| Switch Position | Main EZ-Board Attached to Emulator | EZ-Board(s) Not Attached to Emulator |
|-----------------|------------------------------------|--------------------------------------|
| SW19.1 | ON | OFF |
| SW19.2 | ON | ON |
| SW19.3 | ON | OFF |
| SW19.4 | ON | ON |
| SW19.5 | ON | OFF |
| SW19.6 | ON | ON |
| SW19.7 | ON | OFF |
| SW19.8 | ON | ON |
| SW20.1 | ON | OFF |
| SW20.2 | OFF | OFF |
| SW21.1 | OFF | OFF |
| SW21.2 | ON | ON |
| SW22.1 | OFF | ON |
| SW22.2 | ON | OFF |

Headphone Enable Switch (SW23)

The headphone enable switch (SW23) connects the AD1939's OUT3 circuit to the 3.5 mm headphone connector (J8). By default, the headphone enable switch is disabled. To use the headphones, set SW23 to all ON. [For more information, see “Headphone Out Connector \(J8\)” on page 2-28.](#)

Audio Loopback Switches (SW24–25)

The audio loopback switches (SW24 and SW25) are used for testing only. The switches loop back any analog signal generated from the AD1939's digital-to-analog converter (DAC) circuit to analog-to-digital converter (ADC) circuit.

Jumpers

This section describes functionality of the configuration jumpers. [Figure 2-2](#) shows the jumper locations.

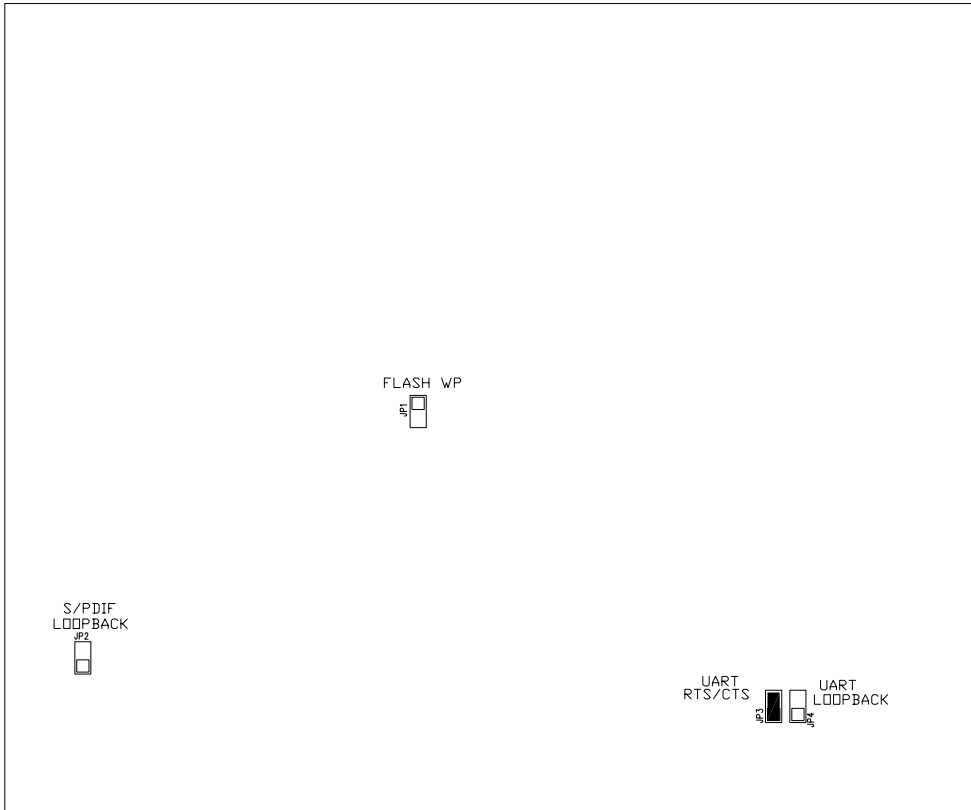

Figure 2-3. Configuration Jumper Locations

Flash WP Jumper (JP1)

The flash WP jumper (JP1) write-protects block 0 of the parallel flash chip. Block 0 is located at address range 0x0400 0000-0x0400 1FFF. The POST begins at block 0 and continues on to other blocks in flash memory. When the jumper is installed on JP1, and the parallel flash driver from Analog Devices is used, block 0 is read-only. By default, JP1 is not installed.

S/PDIF Loopback Jumper (JP2)

The S/PDIF loop back jumper (JP2) is used for internal testing only. The jumper loops back any digital audio signal from the S/PDIF's Data Out pin to the S/PDIF's Data In pin. By default, JP2 is not installed.

UART RTS/CTS Jumper (JP3)

The UART RTS/CTS jumper (JP3) connects the RTS and CTS pins of the RS-232 interface. By default, JP3 is installed.

UART Loopback Jumper (JP4)

The UART loop back jumper (JP4) is used for internal testing only. The jumper loops back the UART receive data from the UART transmit data. By default, JP4 is not installed.

LEDs

LEDs

This section describes the on-board LEDs. [Figure 2-4](#) shows the LED locations.

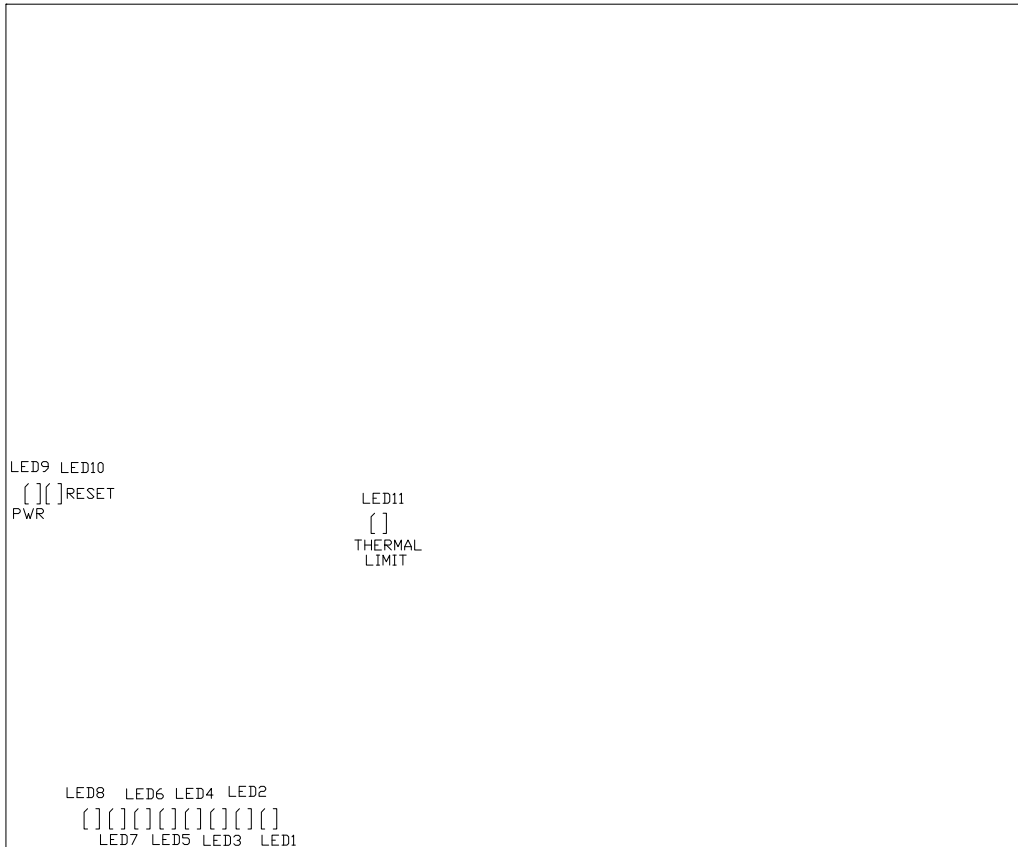

Figure 2-4. LED Locations

GPIO LEDs (LED1–8)

Eight LEDs connect to the DAI and DPI pins of the processor; see [Table 2-18](#). The LEDs are active high and lit by writing a ‘1’ to the correct DAI or DPI pin.

Table 2-18. GPIO LEDs

| LED Reference Designator | Processor Pin |
|--------------------------|---------------|
| LED1 | DPI_P6 |
| LED2 | DPI_P13 |
| LED3 | DPI_14 |
| LED4 | DAI_P3 |
| LED5 | DAI_P4 |
| LED6 | DAI_P15 |
| LED7 | DAI_P16 |
| LED8 | DAI_P17 |

Power LED (LED9)

When LED9 is lit solid, it indicates that the board is powered.

Reset LED (LED10)

When LED10 is lit, it indicates that a master reset of all major ICs is active. The reset LED is controlled by the Analog Devices ADM708 supervisory reset circuit. You can assert the reset push button (SW12) to assert a master reset and activate LED10. [For more information, see “Reset Push Button \(SW12\)” on page 2-12.](#)

Thermal Limit LED (LED11)

The thermal limit LED (LED11) reports a status of the thermal sensor, ADM1032 (U43). The thermal sensor monitors the processor's temperature. When the high temperature limit set by the IC is violated, LED11 is turned on as a visual indicator. The ADM1032 has built-in hysteresis, which causes the LED to de-activate only when the temperature is significantly within the limit. [For more information, see “Temperature Sensor Interface” on page 1-17.](#)

Connectors

This section describes connector functionality and provides information about mating connectors. The connector locations are shown in [Figure 2-5](#).

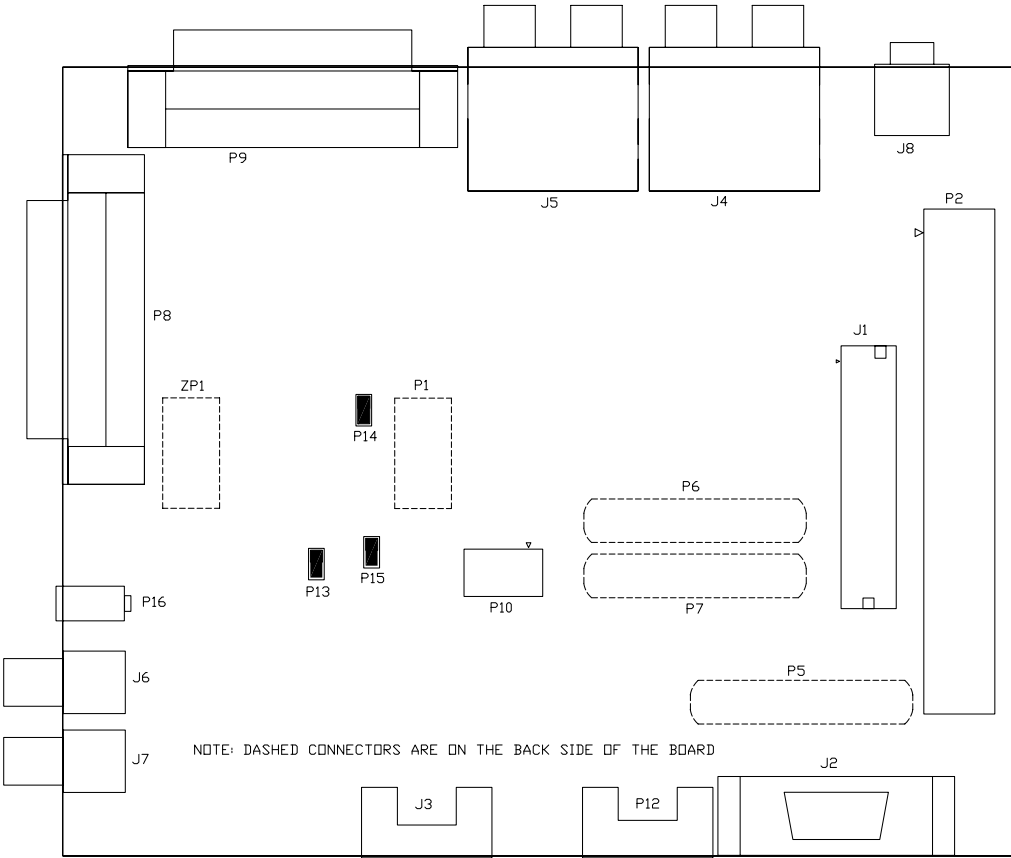

Figure 2-5. Connector Locations

Connectors

Expansion Interface II Connector (J1)

J1 is a board-to-board connector providing signals from the asynchronous memory interface (AMI) of the processor. The connector is located on the right edge of the board. For more information, see [“Expansion Interface II” on page 1-25](#). For availability and pricing of the connector, contact Samtec.

| Part Description | Manufacturer | Part Number |
|---------------------------------|--------------|---------------------|
| 104-position 0.025", SMT header | SAMTEC | QMS-052-06.75-L-D-A |
| Mating Connector | | |
| 104-position 0.025", SMT socket | SAMTEC | QFS-052-04.25-L-D-A |

RS-232 Connector (J2)

| Part Description | Manufacturer | Part Number |
|-----------------------------|--------------|-------------------|
| DB9, female, vertical mount | NORCOMP | 191-009-213-L-571 |
| Mating Cable | | |
| 2m female-to-female cable | DIGI-KEY | AE1020-ND |

Link Port 1 Connector (J3)

| Part Description | Manufacturer | Part Number |
|----------------------------|--------------|--------------------------|
| ERF8 10X2, RA female | SAMTEC | ERF8-010-01-S-D-RA-L |
| Mating Cable | | |
| 6" cable ERF8 to ERM8 10X2 | SAMTEC | ERCD-010-06.00-TBL-SBR-1 |

RCA Audio Connector (J4)

| Part Description | Manufacturer | Part Number |
|--|--------------|--------------|
| RCA 2x3 | KYOYAKU ENT | WSP-256V1-09 |
| Mating Cable (shipped with the EZ-KIT) | | |
| 6' RCA audio cable | CABLESTOGO | 03171 |

RCA Audio Connector (J5)

| Part Description | Manufacturer | Part Number |
|--|--------------|--------------|
| RCA 2x3 | KYOYAKU ENT | WSP-256V1-09 |
| Mating Cable (shipped with the EZ-KIT) | | |
| 6' RCA audio cable | CABLESTOGO | 03171 |

S/PDIF IN Connector (J6)

| Part Description | Manufacturer | Part Number |
|--|--------------|--------------|
| RCA 1X1 | SWITCHCRAFT | PJРАН1X1U01X |
| Mating Cable (shipped with the EZ-KIT) | | |
| 6' RCA audio cable | CABLESTOGO | 03171 |

S/PDIF OUT Connector (J7)

| Part Description | Manufacturer | Part Number |
|--|--------------|--------------|
| RCA 1X1 | SWITCHCRAFT | PJРАН1X1U01X |
| Mating Cable (shipped with the EZ-KIT) | | |
| 6' RCA audio cable | CABLESTOGO | 03171 |

Connectors

Headphone Out Connector (J8)

| Part Description | Manufacturer | Part Number |
|---|--------------|-------------|
| 3.5mm stereo_jack | CUI | SJ1-3525NG |
| Mating Headphones (shipped with the EZ-KIT) | | |
| Stereo headphones | KOSS | 151225 UR5 |

JTAG Connector (P1)

The P1 connector provides access to the JTAG signals of the ADSP-21469 processor. The standalone debug agent requires two connectors, P1 and ZP1. Pin 3 is missing to provide keying. Pin 3 in the mating connector must have a plug. [For more information, see “JTAG Interface” on page 1-23.](#)

Remove the standalone debug agent when an emulator is used with the EZ-Board. Follow the installation instructions provided in [“CCES Install and Session Startup” on page 1-5](#) or [“VisualDSP++ Install and Session Startup” on page 1-9](#), using P1 as the JTAG connection point.

Expansion Interface II Connector (P2)

P2 is a board-to-board connector providing signals for the DAI and DPI interfaces and GPIO signals of the processor. The connector is located on the right edge of the board. [For more information, see “Expansion Interface II” on page 1-25.](#) For availability and pricing of the connectors, contact Samtec.

| Part Description | Manufacturer | Part Number |
|------------------------------|--------------|--------------------|
| 60-position 0.1”, SMT header | SAMTEC | TSSH-130-01-L-DV-A |
| Mating Connector | | |
| 60-position 0.1”, SMT socket | SAMTEC | SSW-130-22-F-D-VS |

DMAX Land Grid Array Connectors (P5–7)

The land grid array areas (P5-7) are intended for probing of the processor signals. The pads are exposed and designed to attach a Tektronix logic analyzer to the connectors listed in the following table. For more information about the land grid array, consult the Tektronix Web site.

| Part Description | Manufacturer | Part Number |
|---------------------|--------------|-------------|
| Primary retention | TEKTRONIX | 020290800 |
| Alternate retention | TEKTRONIX | 020291000 |

Differential In/Out Connectors (P8–9)

The differential in and out connectors (P8-9) are intended for an evaluation of the AD1939 codec via XLR connectors. A standard, off the shelf DB25 connector to XLR cables is required; the cable details can be found in the following table.

| Part Description | Manufacturer | Part Number |
|-------------------------|--------------|-------------|
| 25-position DB25 socket | TYCO | 1734350-2 |
| Mating cables | | |
| Snake (8)XLRF-25P 9.9' | HOSA | DTF-803 |
| Snake (8)XLRM-25P 9.9' | HOSA | DTM-803 |

MLB Connector (P10)

The media local bus (MLB) connector (P10) is intended for an evaluation of the ADSP-21462 processor's MLB interface. P10 is not available on the ADSP-21469 EZ-Board because the ADSP-21469 processor does not support MLB.

Connectors

Link Port 0 Connector (P12)

| Part Description | Manufacturer | Part Number |
|----------------------------|--------------|--------------------------|
| ERM8 10X2, RA Male | SAMTEC | ERM8-010-01-S-D-RA |
| Mating Cable | | |
| 6" cable ERF8 to ERM8 10X2 | SAMTEC | ERCD-010-06.00-TBL-SBR-1 |

VDD_DDR2 Power Connector (P13)

The VDD_DDR2 power connector (P13) is used to measure voltage and current supplied to the DDR2 memory interface of the processor. By default, P13 is ON, and the power flows through the two-pin IDC header. To measure power, remove the jumper on P13 and measure voltage across the 0.1 ohm resistor. Once voltage is measured, power can be calculated. For more information, refer to [“Power Measurements” on page 1-26](#).

VDDINT Power Connector (P14)

The VDDINT power connector (P14) is used to measure voltage and current supplied to the processor core. By default, P14 is ON, and the power flows through the two-pin IDC header. To measure power, remove the jumper on P14 and measure voltage across the 0.1 ohm resistor. Once voltage is measured, power can be calculated. For more information, refer to [“Power Measurements” on page 1-26](#).

VDDEXT Power Connector (P15)

The VDDEXT power connector (P15) is used to measure the processor’s I/O voltage and current. By default, P15 is ON, and the power flows through the two-pin IDC header. To measure power, remove the jumper on P15 and measure voltage across the 0.1 ohm resistor. Once voltage is measured, power can be calculated. For more information, refer to [“Power Measurements” on page 1-26](#).

Power Connector (P16)

The power connector (P16) provides all of the power necessary to operate the EZ-Board.

| Part Description | Manufacturer | Part Number |
|---|--------------|-------------|
| 0.65 mm power jack | CUI | 045-0883R |
| Mating Power Supply (shipped with the EZ-Board and EZ-KIT) | | |
| 5.0VDC@3.6A power supply | GLOBTEK | GS-1750(R) |

Standalone Debug Agent Connector (ZP1)

ZP1 connects the standalone debug agent to the EZ-Board. The standalone debug agent requires two connectors, ZP1 and P1. [For more information, see “JTAG Connector \(P1\)” on page 2-28.](#)

Connectors

A ADSP-21469 EZ-BOARD BILL OF MATERIALS

The bill of materials corresponds to “[ADSP-21469 EZ-Board Schematic](#)” on page B-1.

| Ref. | Qty. | Description | Reference Designator | Manufacturer | Part Number |
|------|------|-----------------------------|----------------------|------------------|------------------|
| 1 | 1 | 74LVC14A SOIC14 | U14 | TI | 74LVC14AD |
| 2 | 1 | IDT74FCT3244 APY SSOP20 | U17 | IDT | IDT74FCT3244APYG |
| 3 | 1 | 12.288MHZ OSC003 | U12 | EPSON | SG-8002CA MP |
| 4 | 1 | 25MHZ OSC003 | U41 | EPSON | SG-8002CA MP |
| 5 | 3 | SN74LVC1G08 SOT23-5 | U48-50 | TI | SN74LVC1G08DBVR |
| 6 | 1 | SN65LVDS2D SOIC8 | U44 | NATIONAL SEMI | DS90LV018ATM |
| 7 | 1 | M25P16 SO8W | U40 | ST MICRO | M25P16-VMW6G |
| 8 | 1 | MT47H64M16 FBGA84 | U2 | MICRON | MT47H64M16HR-3 |
| 9 | 1 | ADM1032 SOIC_N8 | U43 | ON SEMI | ADM1032ARZ |
| 10 | 2 | SI7601DN ICS010 | U15-16 | VISHAY | SI7601DN |
| 11 | 1 | 21469 M29W320EB "U18" | U18 | ST MICRO | M29W320EB70ZE6E |

| Ref. | Qty. | Description | Reference Designator | Manufacturer | Part Number |
|------|------|------------------------|---------------------------------|-------------------|--------------------|
| 12 | 1 | ADM708SARZ SOIC8 | U46 | ANALOG DEVICES | ADM708SARZ |
| 13 | 1 | ADM3202ARNZ SOIC16 | U42 | ANALOG DEVICES | ADM3202ARNZ |
| 14 | 1 | ADSP-21469 PBGA324 | U1 | ANALOG DEVICES | ADSP-21469KBZ-ENG |
| 15 | 2 | ADP1864AUJZ SOT23-6 | VR2-3 | ANALOG DEVICES | ADP1864AUJZ-R7 |
| 16 | 1 | ADP1710 TSOT5 | VR1 | ANALOG DEVICES | ADP1710AUJZ-R7 |
| 17 | 1 | ADP1715 MSOP8 | VR4 | ANALOG DEVICES | ADP1715ARMZ-1.8-R7 |
| 18 | 1 | AD1939 LQFP64 | U45 | ANALOG DEVICES | AD1939YSTZ |
| 19 | 16 | AD8652ARZ SOIC_N8 | U20-26,U28-30,U32-3 4,U36-38 | ANALOG DEVICES | AD8652ARZ |
| 20 | 1 | AD8397 SOIC_N8_EP | U51 | ANALOG DEVICES | AD8397ARDZ |
| 21 | 1 | ADM1085 SC70_6 | U52 | ANALOG DEVICES | ADM1085AKSZ-REEL7 |
| 22 | 2 | RCA 1X1 CON012 | J6-7 | SWITCH- CRAFT | PJRRAN1X1U01X |
| 23 | 5 | MOMENTARY SWT013 | SW8-12 | PANASONIC | EVQ-PAD04M |
| 24 | 4 | DIP8 SWT016 | SW1-3,SW19 | C&K | TDA08H0SB1 |
| 25 | 6 | DIP6 SWT017 | SW13-18 | CTS | 218-6LPST |
| 26 | 3 | DIP4 SWT018 | SW7,SW24-25 | ITT | TDA04HOSB1 |
| 27 | 1 | DB9 9PIN CON038 | J2 | NORCOMP | 191-009-213-L-571 |
| 28 | 5 | DIP2 SWT020 | SW5,SW20-23 | C&K | CKN9064-ND |

ADSP-21469 EZ-Board Bill Of Materials

| Ref. | Qty. | Description | Reference Designator | Manufacturer | Part Number |
|------|------|--------------------------------|----------------------|-----------------|----------------------|
| 29 | 3 | IDC 2X1 IDC2X1 | P13-15 | FCI | 90726-402HLF |
| 30 | 4 | IDC 2X1 IDC2X1 | JP1-4 | FCI | 90726-402HLF |
| 31 | 3 | IDC 2PIN_JUMPER_ SHORT | SJ1-3 | DIGI-KEY | S9001-ND |
| 32 | 1 | 3.5MM STEREO_JACK CON001 | J8 | DIGI-KEY | CP1-3525NG-ND |
| 33 | 1 | PWR .65MM CON045 | P16 | CUI | 045-0883R |
| 34 | 1 | 5A RESETABLE FUS005 | F1 | MOUSER | 650-RGEF500 |
| 35 | 1 | QMS 52x2 QMS52x2_SMT | J1 | SAMTEC | QMS-052-06.75-L-D-A |
| 36 | 1 | IDC 7x2 IDC7x2_SMTA | P1 | SAMTEC | TSM-107-01-T-DV-A |
| 37 | 1 | ROTARY SWT027 | SW4 | COPAL | S-8110 |
| 38 | 2 | RCA 2x3 CON_RCA_6B | J4-5 | KYOYAKU ENT. | WSP-256V1-09 |
| 39 | 1 | ERM8 10X2 ERM8_10X2_S MT | P12 | SAMTEC | ERM8-010-01-S-D-RA |
| 40 | 1 | ERF8 10X2 ERF8_10X2_SM T | J3 | SAMTEC | ERF8-010-01-S-D-RA-L |
| 41 | 2 | DB25 25PIN DB25F | P8-9 | TYCO | 1734350-2 |
| 42 | 1 | IDC 30x2 IDC30X2_SMTA | P2 | SAMTEC | TSSH-130-01-L-DV-A |

| Ref. | Qty. | Description | Reference Designator | Manufacturer | Part Number |
|------|------|--------------------------|---|--------------|----------------|
| 43 | 9 | YELLOW LED001 | LED1-8,LED11 | PANASONIC | LN1461C |
| 44 | 2 | 22PF 50V 5% 0805 | C262-263 | AVX | 08055A220JAT |
| 45 | 2 | 0.22UF 25V 10% 0805 | C126-127 | AVX | 08053C224KAT2A |
| 46 | 1 | 0.1UF 50V 10% 0805 | C123 | AVX | 08055C104KAT |
| 47 | 1 | 600 100MHZ 200MA 0603 | FER5 | DIGI-KEY | 490-1014-2-ND |
| 48 | 2 | 600 100MHZ 500MA 1206 | FER7-8 | STEWARD | HZ1206B601R-10 |
| 49 | 2 | 10UF 16V 20% CAP002 | CT59-60 | PANASONIC | EEE1CA100SR |
| 50 | 1 | 190 100MHZ 5A FER002 | FER9 | MURATA | DLW5BSN191SQ2 |
| 51 | 8 | 10UF 6.3V 10% 0805 | C97-98,C100-101, C103-104,C254, C257 | AVX | 08056D106KAT2A |
| 52 | 2 | 4.7UF 6.3V 10% 0805 | C240,C246 | AVX | 08056D475KAT2A |
| 53 | 35 | 0.1UF 10V 10% 0402 | C26-27,C53,C117- 120,C148,C151-152, C160,C162,C169- 170,C178,C188-189, C191,C197,C199- 200,C211,C213-214, C225,C227-228, C237,C264,C267- 271,C273 | AVX | 0402ZD104KAT2A |

ADSP-21469 EZ-Board Bill Of Materials

| Ref. | Qty. | Description | Reference Designator | Manufacturer | Part Number |
|------|------|---------------------|---|--------------|------------------|
| 54 | 94 | 0.01UF 16V 10% 0402 | C28,C30-43,C45-50, C52,C54-96,C99, C102,C105-116, C121-122,C125, C128-131,C136-142, C266 | AVX | 0402YC103KAT2A |
| 55 | 33 | 10K 1/16W 5% 0402 | R99,R190,R196-200, R202,R205-210,R217, R224-225,R233-239, R256,R259-260, R463-466,R469,R494 | VISHAY | CRCW040210K0FKED |
| 56 | 2 | 4.7K 1/16W 5% 0402 | R185,R501 | VISHAY | CRCW04024K70JNED |
| 57 | 4 | 0 1/16W 5% 0402 | R462,R485,R492, R498 | PANASONIC | ERJ-2GE0R00X |
| 58 | 1 | 22 1/16W 5% 0402 | R230 | PANASONIC | ERJ-2GEJ220X |
| 59 | 13 | 33 1/16W 5% 0402 | R191-192,R201, R203-204,R211, R257-258,R261-263, R495-496 | VISHAY | CRCW040233R0JNEA |
| 60 | 1 | 100UF 10V 10% C | CT61 | AVX | TPSC107K010R0075 |
| 61 | 2 | 2.2UF 10V 10% 0805 | C238-239 | AVX | 0805ZD225KAT2A |
| 62 | 1 | 1000PF 50V 5% 0402 | C51 | AVX | 04025C102JAT2A |
| 63 | 2 | 1A SK12 DO-214AA | D4-5 | DIODES INC | B120B-13-F |
| 64 | 1 | 107.0 1/10W 1% 0805 | R228 | DIGI-KEY | 311-107CRTR-ND |
| 65 | 1 | 249.0 1/10W 1% 0805 | R227 | DIGI-KEY | 311-249CRTR-ND |

| Ref. | Qty. | Description | Reference Designator | Manufacturer | Part Number |
|------|------|------------------------|--|--------------|------------------|
| 66 | 2 | 0.1UF 16V 10% 0603 | C255-256 | AVX | 0603YC104KAT2A |
| 67 | 2 | 1UF 16V 10% 0603 | C260-261 | PANASONIC | ECJ-1VB1C105K |
| 68 | 2 | 68PF 50V 5% 0603 | C243,C249 | AVX | 06035A680JAT2A |
| 69 | 2 | 470PF 50V 5% 0603 | C242,C248 | AVX | 06033A471JAT2A |
| 70 | 1 | 220UF 6.3V 20% D2E | CT45 | SANYO | 10TPE220ML |
| 71 | 11 | 330 1/10W 5% 0603 | R248-255,R467-468, R497 | VISHAY | CRCW0603330RJNEA |
| 72 | 2 | 0 1/10W 5% 0603 | R452,R458 | PHYCOMP | 232270296001L |
| 73 | 4 | 10 1/10W 5% 0603 | R244-247 | VISHAY | CRCW060310R0JNEA |
| 74 | 1 | 10.0K 1/16W 1% 0603 | R231 | DALE | CRCW060310K0FKEA |
| 75 | 8 | 237.0 1/10W 1% 0603 | R267,R272,R280, R285,R293,R298-299, R304 | DIGI-KEY | 311-237HRTR-ND |
| 76 | 24 | 49.9K 1/10W 1% 0603 | R265,R271,R282, R284,R295,R297, R300,R302,R310, R336-337,R343-344, R363-364,R369,R378, R397-398,R403,R412, R431-432,R437 | DIGI-KEY | 311-49.9KHRTR-ND |
| 77 | 1 | 75.0 1/10W 1% 0603 | R229 | DALE | CRCW060375R0FKEA |
| 78 | 4 | 1UF 6.3V 20% 0402 | C132-135 | PANASONIC | ECJ-0EB0J105M |

ADSP-21469 EZ-Board Bill Of Materials

| Ref. | Qty. | Description | Reference Designator | Manufacturer | Part Number |
|------|------|------------------------|--|--------------|------------------|
| 79 | 4 | 100 1/16W 5% 0402 | R240-243 | DIGI-KEY | 311-100JRTR-ND |
| 80 | 1 | 562.0 1/10W 1% 0603 | R461 | VISHAY | CRCW0603562RFKEA |
| 81 | 1 | 390PF 25V 5% 0603 | C258 | AVX | 06033A391FAT2A |
| 82 | 1 | 5600PF 16V 5% 0805 | C259 | AVX | 0805YA562JAT2A |
| 83 | 1 | 15.0K 1/16W 1% 0603 | R232 | DIGI-KEY | 311-15.0KHRTR-ND |
| 84 | 40 | 4.99K 1/16W 1% 0603 | R264,R273,R278-279, R291-292,R305-306, R311,R313-314,R324, R326-328,R342, R349-350,R352-354, R357,R366,R371, R383-384,R386-388, R391,R400,R405, R417-418,R420-422, R425,R434,R439 | VISHAY | CRCW06034K99FKEA |
| 85 | 2 | 24.9K 1/10W 1% 0603 | R448,R454 | DIGI-KEY | 311-24.9KHTR-ND |
| 86 | 1 | 31.6K 1/16W 1% 0603 | R473 | PANASONIC | ERJ-3EKF3162V |
| 87 | 3 | 10UF 10V 10% 0805 | C29,C161,C265 | PANASONIC | ECJ-2FB1A106K |
| 88 | 8 | 5.76K 1/16W 1% 0603 | R266,R269,R277, R281,R290,R294, R303,R307 | PANASONIC | ERJ-3EKF5761V |
| 89 | 3 | 0.05 1/2W 1% 1206 | R446,R459-460 | SEI | CSF 1/2 0.05 1%R |
| 90 | 3 | 10UF 16V 10% 1210 | C244-245,C250 | AVX | 1210YD106KAT2A |
| 91 | 1 | GREEN LED001 | LED9 | PANASONIC | LN1361CTR |

| Ref. | Qty. | Description | Reference Designator | Manufacturer | Part Number |
|------|------|-------------------------|--|--------------|------------------|
| 92 | 1 | RED LED001 | LED10 | PANASONIC | LN1261CTR |
| 93 | 2 | 1000PF 50V 5% 1206 | C236,C251 | AVX | 12065A102JAT2A |
| 94 | 1 | 255.0K 1/10W 1% 0603 | R447 | VISHAY | CRCW06032553FK |
| 95 | 2 | 80.6K 1/10W 1% 0603 | R449,R455 | DIGI-KEY | 311-80.6KHRCT-ND |
| 96 | 3 | 5A MBRS540T3G SMC | D1-3 | ON SEMI | MBRS540T3G |
| 97 | 2 | 2.5UH 30% IND013 | L1-2 | COILCRAFT | MSS1038-252NLB |
| 98 | 3 | 1.0K 1/16W 1% 0402 | R194-195,R287 | PANASONIC | ERJ-2RKF1001X |
| 99 | 1 | 8.20K 1/10W 1% 0603 | R502 | DIGI-KEY | 541-8.20KHCT-ND |
| 100 | 6 | 10.0K 1/16W 1% 0402 | R474,R486-488,R491, R499 | DIGI-KEY | 541-10.0KLCT-ND |
| 101 | 10 | 100K 1/16W 5% 0402 | R475-484 | DIGI-KEY | 541-100KJTR-ND |
| 102 | 1 | 30.9K 1/16W 1% 0402 | R453 | DIGI-KEY | 541-30.9KLCT-ND |
| 103 | 25 | 33 1/32W 5% RNS005 | RN1-14,RN18,RN22, RN26-34 | PANASONIC | EXB-28V330JX |
| 104 | 4 | 51.1 1/16W 1% 0402 | R218-221 | DIGI-KEY | 541-51.1LCT-ND |
| 105 | 16 | 2.67K 1/16W 1% 0402 | R316,R318,R322, R338,R367-368,R373, R377,R401-402,R407, R411,R435-436,R441, R445 | PANASONIC | ERJ-2RKF2671X |

ADSP-21469 EZ-Board Bill Of Materials

| Ref. | Qty. | Description | Reference Designator | Manufacturer | Part Number |
|------|------|-----------------------|--|--------------|---------------------|
| 106 | 31 | 100.0 1/16W 1% 0402 | R193,R274-275,R288, R309,R331-335,R340, R351,R358-362,R385, R392-396,R419, R426-430,R489-490 | DIGI-KEY | 541-100LCT-ND |
| 107 | 2 | 47UF 16V 20% ELEC_6MM | CT57-58 | PANASONIC | EEE-FC1C470P |
| 108 | 4 | 37.4K 1/16W 1% 0402 | R268,R276,R289, R308 | DIGI-KEY | 541-37.4KLCT-ND |
| 109 | 8 | 1000PF 50V 5% 0402 | C144,C150,C154, C159,C164,C168, C171,C176 | DIGI-KEY | 490-3244-1-ND |
| 110 | 4 | 100pF 50V 5% 0402 | C147,C155,C165, C175 | MURATA | GCM1555C1H101JZ13 D |
| 111 | 8 | 300PF 100V 5% 0603 | C143,C145,C153, C157,C163,C173, C177,C179 | DIGI-KEY | 490-1362-1-ND |
| 112 | 16 | 2.43K 1/16W 1% 0402 | R315,R319,R323, R325,R346-347, R374-375,R380-381, R408-409,R414-415, R442-443 | DIGI-KEY | 541-2.43KLCT-ND |
| 113 | 16 | 750.0 1/16W 1% 0402 | R317,R320-321,R341, R345,R348,R372, R376,R379,R382, R406,R410,R413, R416,R440,R444 | DIGI-KEY | 541-750LCT-ND |
| 114 | 16 | 620PF 50V 5% 0402 | C181,C186-187, C192,C194-195, C201,C204,C208-209,C215,C218, C222-223,C229,C232 | DIGI-KEY | 490-3239-1-ND |

| Ref. | Qty. | Description | Reference Designator | Manufacturer | Part Number |
|------|------|------------------------------|--|--------------|------------------|
| 115 | 16 | 680PF 50V 5% 0402 | C182-183,C185, C193,C202-203, C206-207,C216-217, C220-221,C230-231, C234-235 | DIGI-KEY | 490-3240-1-ND |
| 116 | 4 | 0.036 1/2W 1% 1206 | R450-451,R456-457 | SUSUMU | RL1632S-R036-F |
| 117 | 1 | 470UF 2.5V 20% D2E | CT47 | SANYO | 2R5TPE470MF |
| 118 | 40 | 22UF 6.3V 20% ELEC_4MM | CT1,CT3,CT5-6, CT8-11,CT14,CT16, CT18-19,CT23-24, CT27-28,CT31-32, CT35-36,CT39-40, CT43-44,CT49-56, CT62-69 | PANASONIC | EEE-FC0J220R |
| 119 | 8 | 22UF 6.3V 20% ELEC_5MM | C180,C184,C196, C205,C210,C219, C224,C233 | MOUSER | 647-UWP0J220MCL |
| 120 | 1 | 5K 1/20W 20% RES_POT_DUAL | R493 | PANASONIC | EJV-Y15F03A53 |
| 121 | 4 | 51 1/32W 5% RNS005 | RN35-38 | DIGI-KEY | EXB-28V510JX |
| 122 | 9 | 10 1/32W 5% RNS005 | RN15-17,RN19-21, RN23-25 | PANASONIC | EXB-28V100JX |
| 123 | 9 | 82 1/32W 5% RNS005 | RN40-48 | PANASONIC | EXB-28V820JX |
| 124 | 9 | 47PF 50V 10% CNS001 | CN1-9 | TDK CORP | CKCL44C0G1H470K |
| 125 | 16 | 6.81K 1/10W 1% 0603 | R312,R329-330,R339, R355-356,R365,R370, R389-390,R399,R404, R423-424,R433,R438 | DIGI-KEY | 311-6.81KHRTR-ND |

ADSP-21469 EZ-Board Bill Of Materials

| Ref. | Qty. | Description | Reference Designator | Manufacturer | Part Number |
|------|------|----------------------------------|----------------------|--------------|------------------|
| 126 | 1 | 806 1/10W 1% 0402 | R286 | VISHAY | CRCW0402806RFKED |
| 127 | 1 | 30A GSOT05 SOT23-3 | D6 | VISHAY | GSOT05-GS08 |
| 128 | 2 | 30A GSOT03 SOT23-3 | D7,D10 | VISHAY | GSOT03-GS08 |
| 129 | 1 | 40A ESD5Z2.5T1 SOD-523 | D8 | ON SEMI | ESD5Z2.5T1G |
| 130 | 1 | 7A VESD01-02V-GS 08 SOD-52 | D9 | VISHAY | VESD01-02V-GS08 |
| 131 | 1 | 16.9K 1/16W 1% 0402 | R500 | VISHAY | CRCW040216K9FKED |

3

4

A

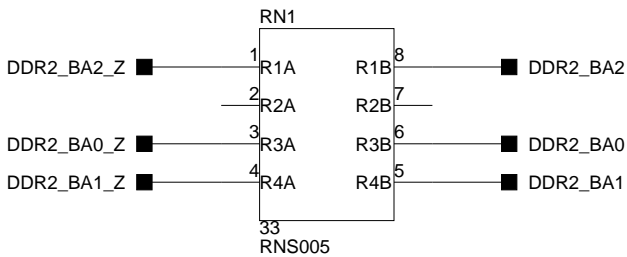
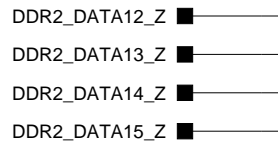
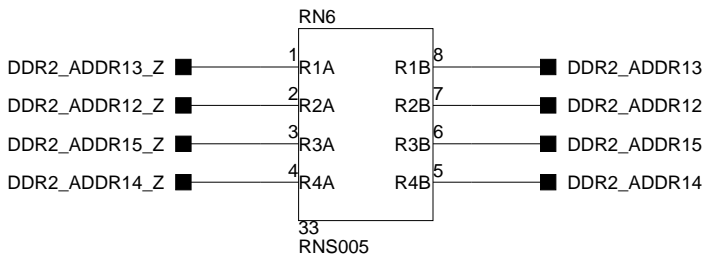
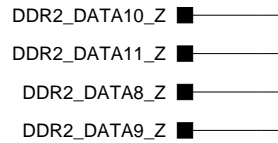
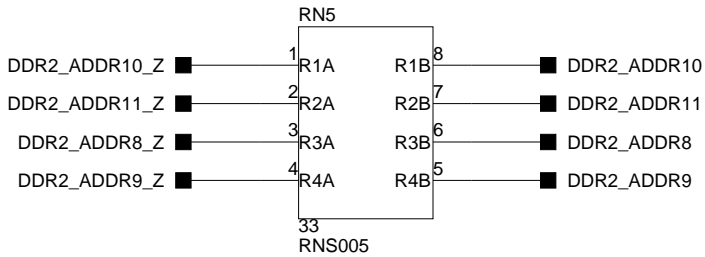
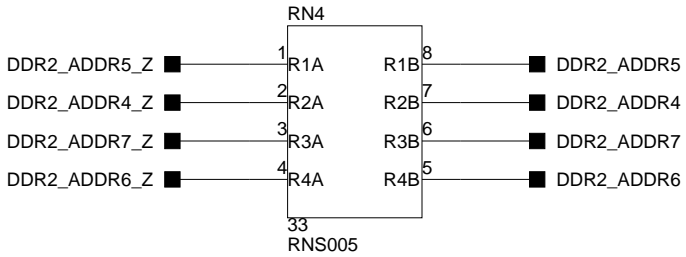
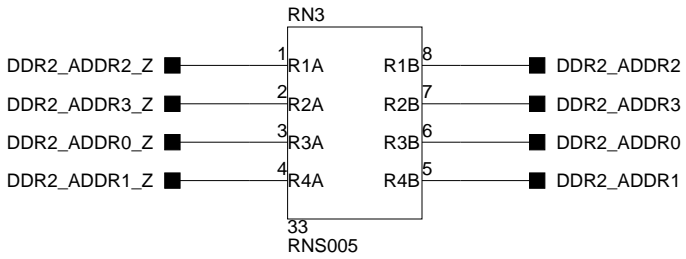

3

4

0.1uF
0402
DNP

XTAL PIN TEST POINT
DO NOT POPULATE C44

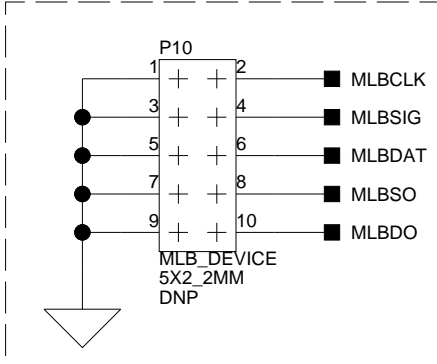

MLB NOT SUPPORTED ON 21469
P10 UNPOPULATED BY DEFAULT
P10 CAN BE USED WITH A 21462 D

3

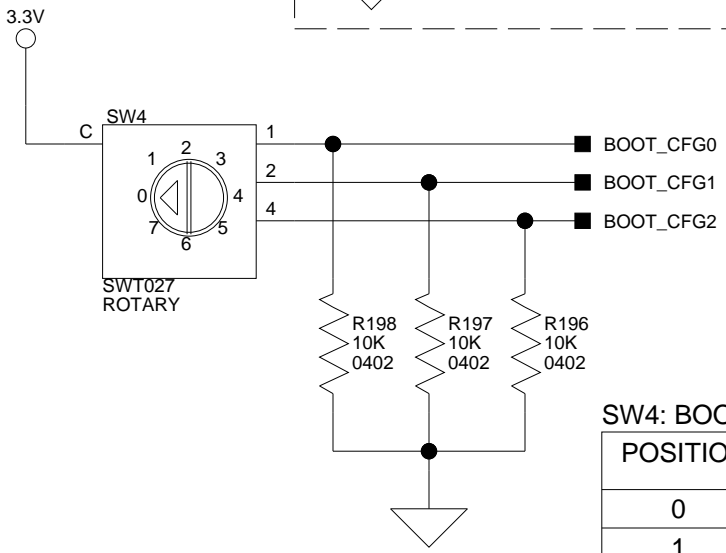

SW4: BOOT MODE SELECT

| POSITION | BOOT MODE |
|------------|---------------------------|
| 0 | SPI Slave Boot |
| 1 | SPI Master Boot |
| 2 | AMI Boot (Parallel Flash) |
| 4 | Link Port 0 Boot |
| 3,5,6 or 7 | Reserved |

DEF

4

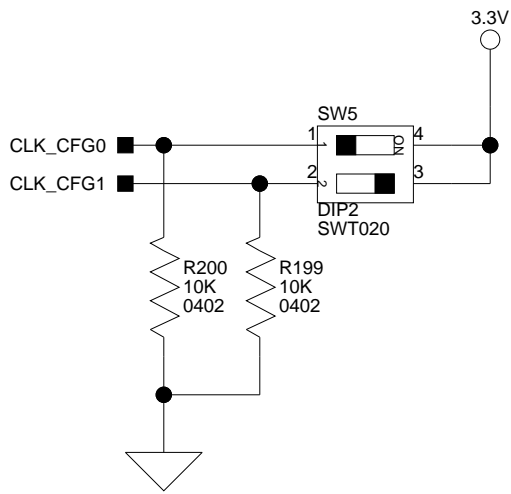

SW5: DSP CLOCK CONFIG

| 1 CLKCFG0 | 2 CLKCFG1 | CLOCK RATIO CORE:CLKIN |
|--------------|--------------|---------------------------|
| ON | ON | Reserved |
| ON | OFF | 32:1 |
| OFF | ON | 16:1 |
| OFF | OFF | 6:1 |

DEF

LINK PORT 1 / JTAG IN

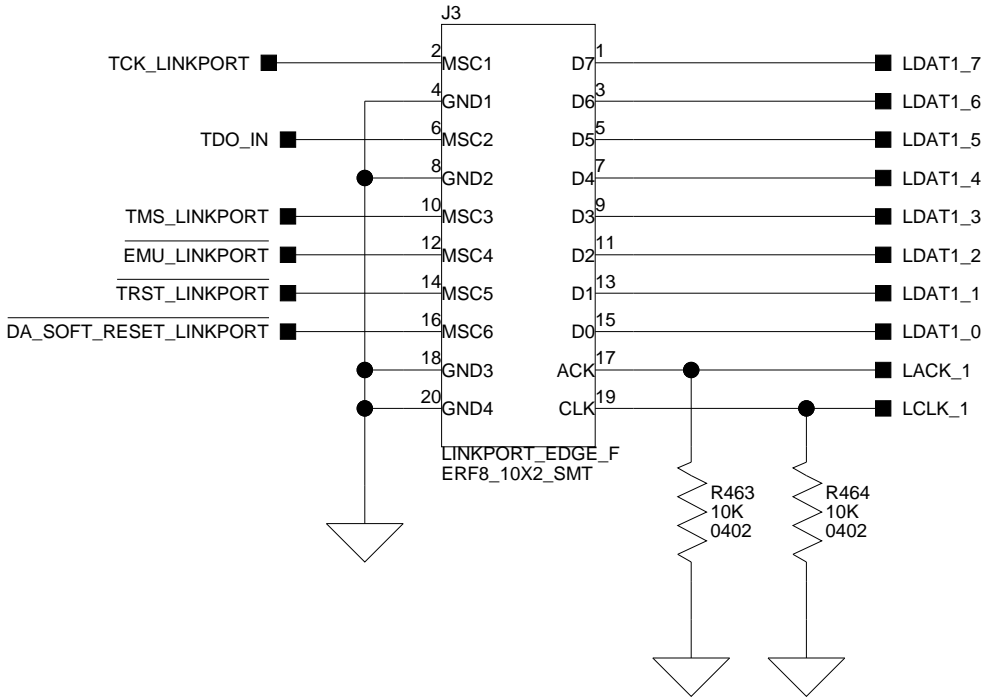

3

LINK PORT 0 / JTAG OUT

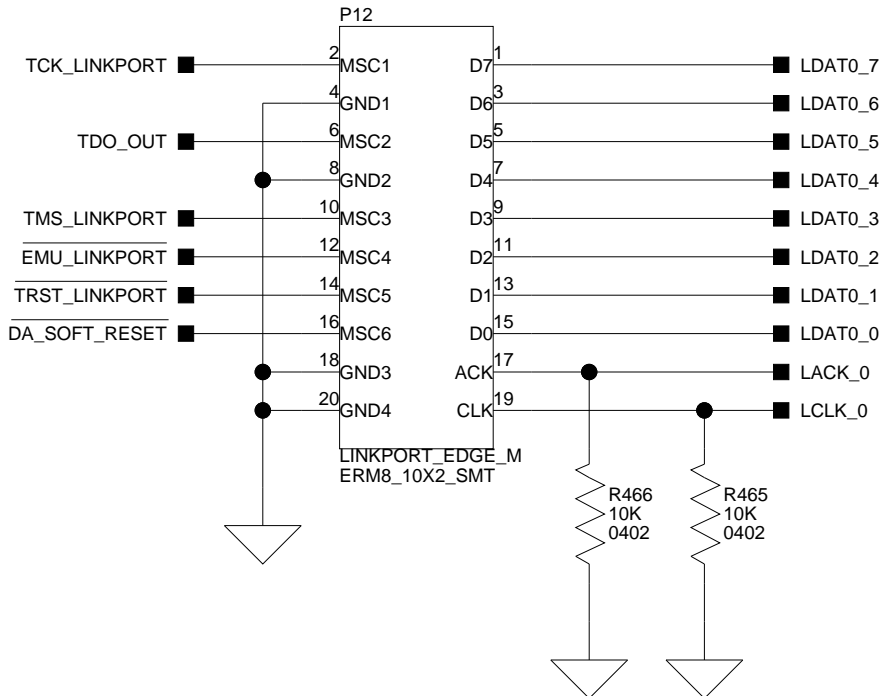

4

VDDINT

FER5
600
0603

C53
0.1UF
0402

C52
0.01UF
0402

C51
1000PF
0402

U8
VDD_EXT17
T8
VDD_EXT18
V9
VDD_EXT19
U9
VDD_EXT20
T9
VDD_EXT21

H1
VDD_A
H2
VSS_A

ADSP-21469
PBGA324

VDD_THD
N10

3

VDD_EXT

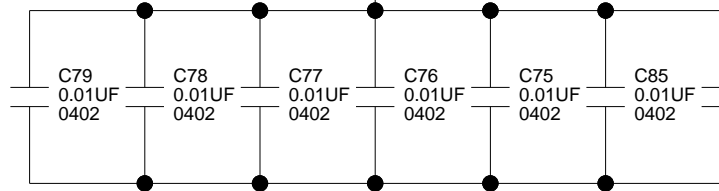

VDD_DDR2

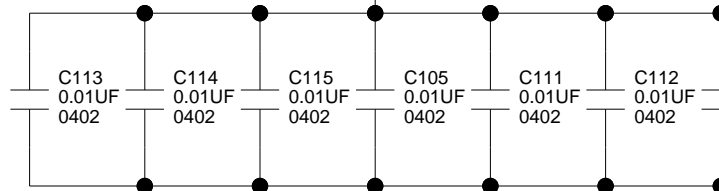

4

A

SINGLE PROCESSOR JTAG SETTINGS
VIA HP-USB EMULATOR OR DEBUG AGENT (DEFAULT)

| SWITCH | BOARD ATTACHED TO EMULATOR |
|--------|----------------------------|
| SW19.1 | ON |
| SW19.2 | OFF |
| SW19.3 | ON |
| SW19.4 | OFF |
| SW19.5 | ON |
| SW19.6 | OFF |
| SW19.7 | ON |
| SW19.8 | OFF |
| | |
| SW20.1 | ON |
| SW20.2 | OFF |
| | |
| SW21.1 | ON |
| SW21.2 | OFF |
| | |
| SW22.1 | OFF |
| SW22.2 | OFF |

JTAG

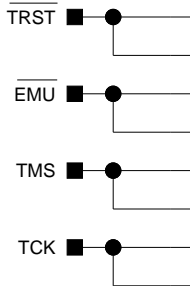

MULTI PROCESSOR JTAG SETTINGS VIA HP-USB EMULATOR
USING TWO OR MORE EZ-BOARDS (LINK PORT CABLES
REQUIRED FOR MORE THAN TWO BOARDS)

| SWITCH | BOARD ATTACHED TO EMULATOR | BOARD(S) NOT ATTACHED TO EMULATOR |
|--------|----------------------------|-----------------------------------|
| SW19.1 | ON | OFF |
| SW19.2 | ON | ON |
| SW19.3 | ON | OFF |
| SW19.4 | ON | ON |
| SW19.5 | ON | OFF |
| SW19.6 | ON | ON |
| SW19.7 | ON | OFF |
| SW19.8 | ON | ON |
| | | |
| SW20.1 | ON | OFF |
| SW20.2 | OFF | OFF |
| | | |
| SW21.1 | OFF | OFF |
| SW21.2 | ON | ON |
| | | |
| SW22.1 | OFF | ON |
| SW22.2 | ON | OFF |



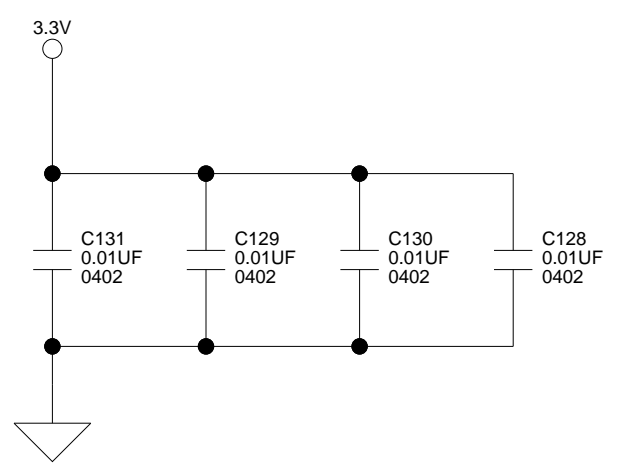
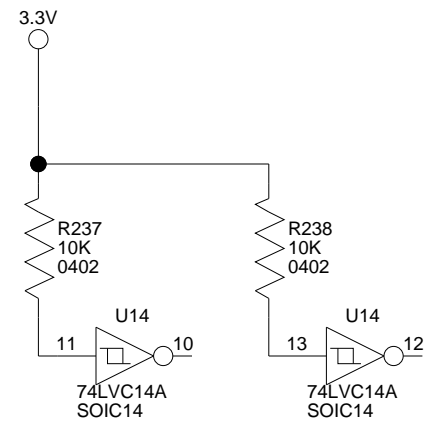
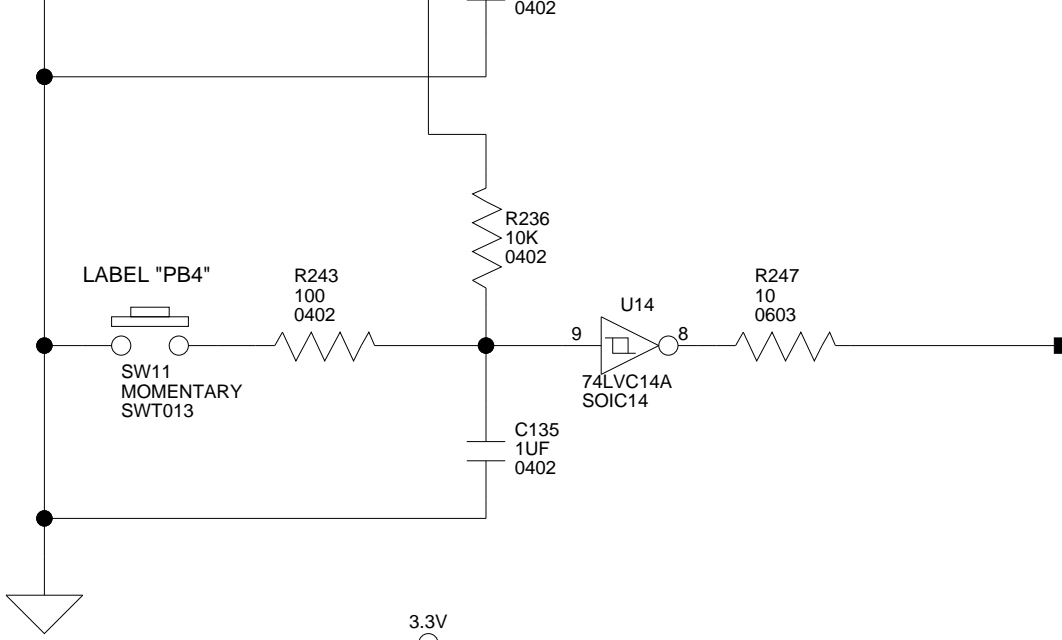

74LVC14A ADM708 IDT74FCT3244 SN74LVC1G08

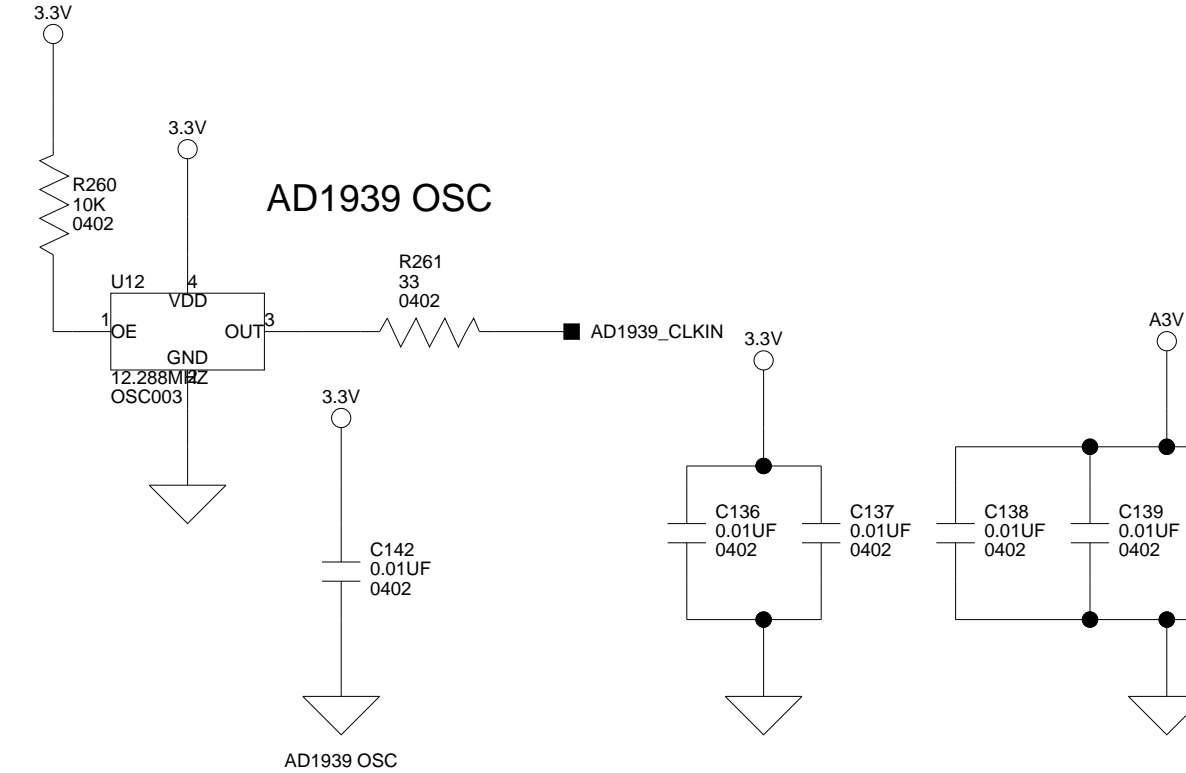
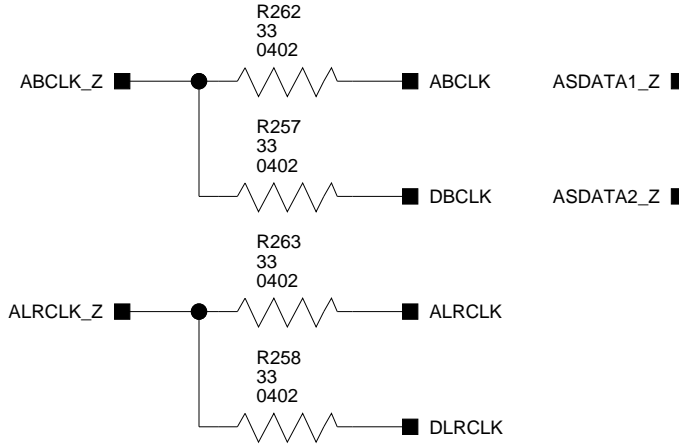
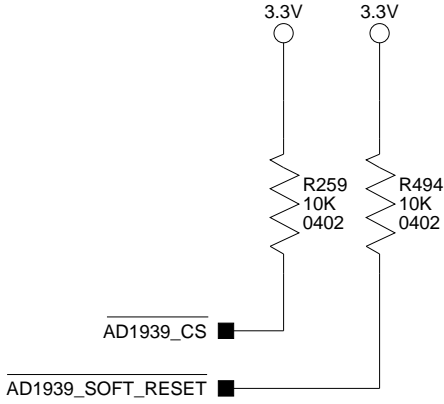

3

4

Bottom Right (Red)

J4

CON_RCA_6B



5

2

IN1_SE_R



SW16

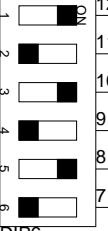

DIP6
SWT017

IN2_R ■

IN2_C ■

ADC2_DIFF- ■

IN2P ■

CT6
22UF
ELEC_4MM



R284
49.9K
0603

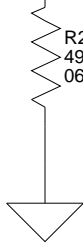

AD1939_V

A

3

Bottom Right (Red)

J5

CON_RCA_6B



5

IN2_SE_R

2



IN4P



AD

4

IN4N



CT9
22UF
ELEC_4MM



R297
49.9K
0603

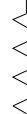

A

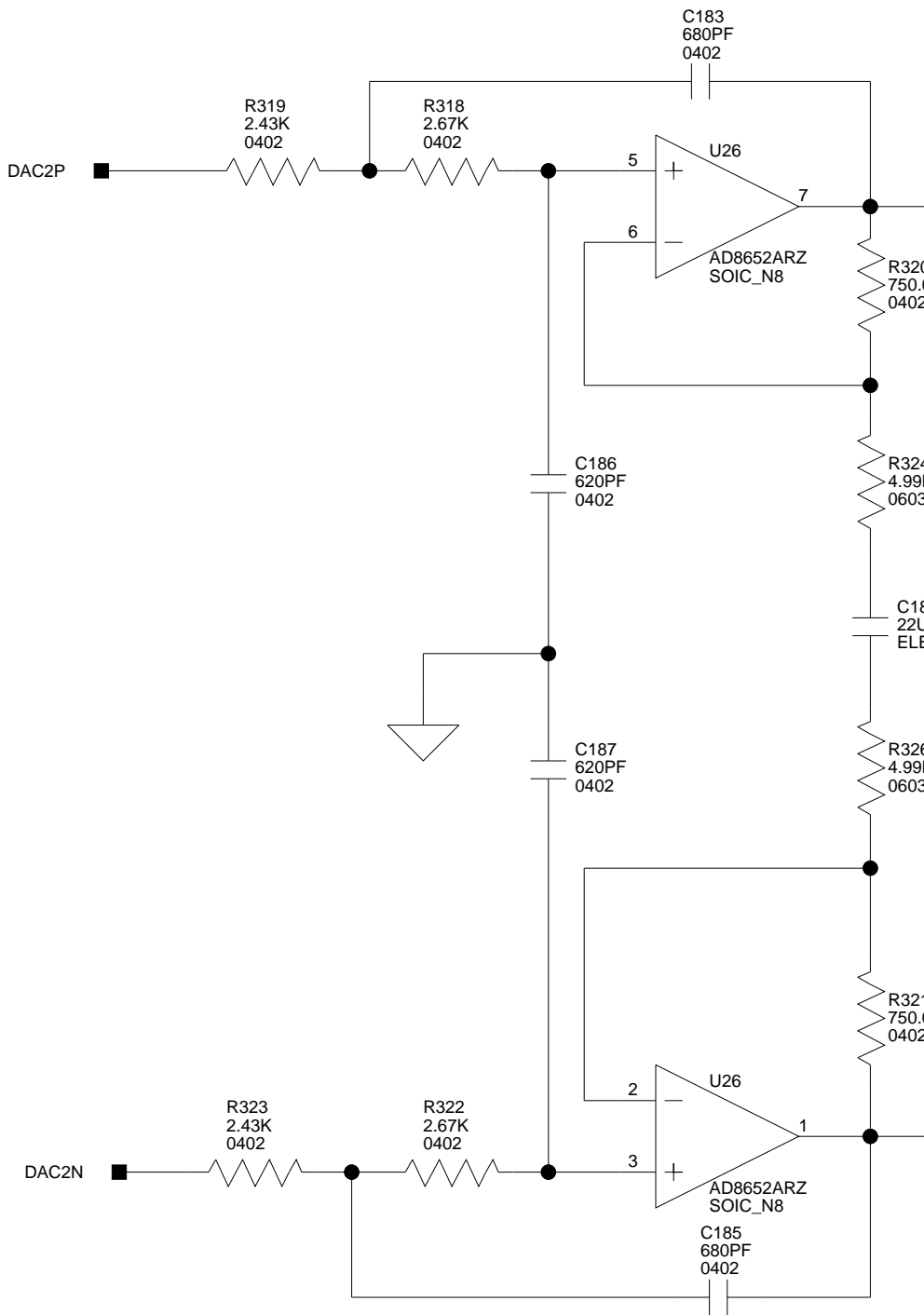

3

4

A

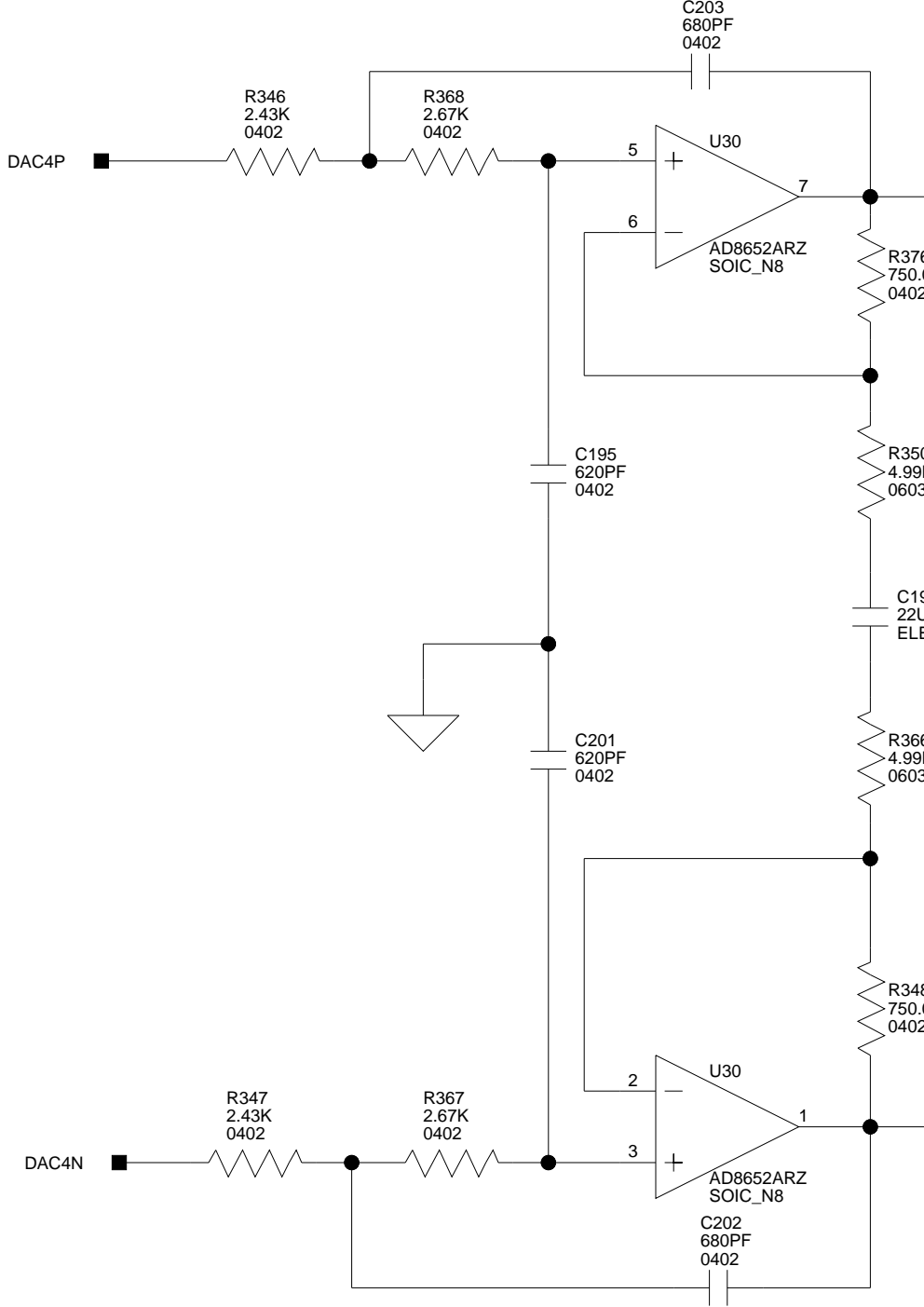

3

4

A

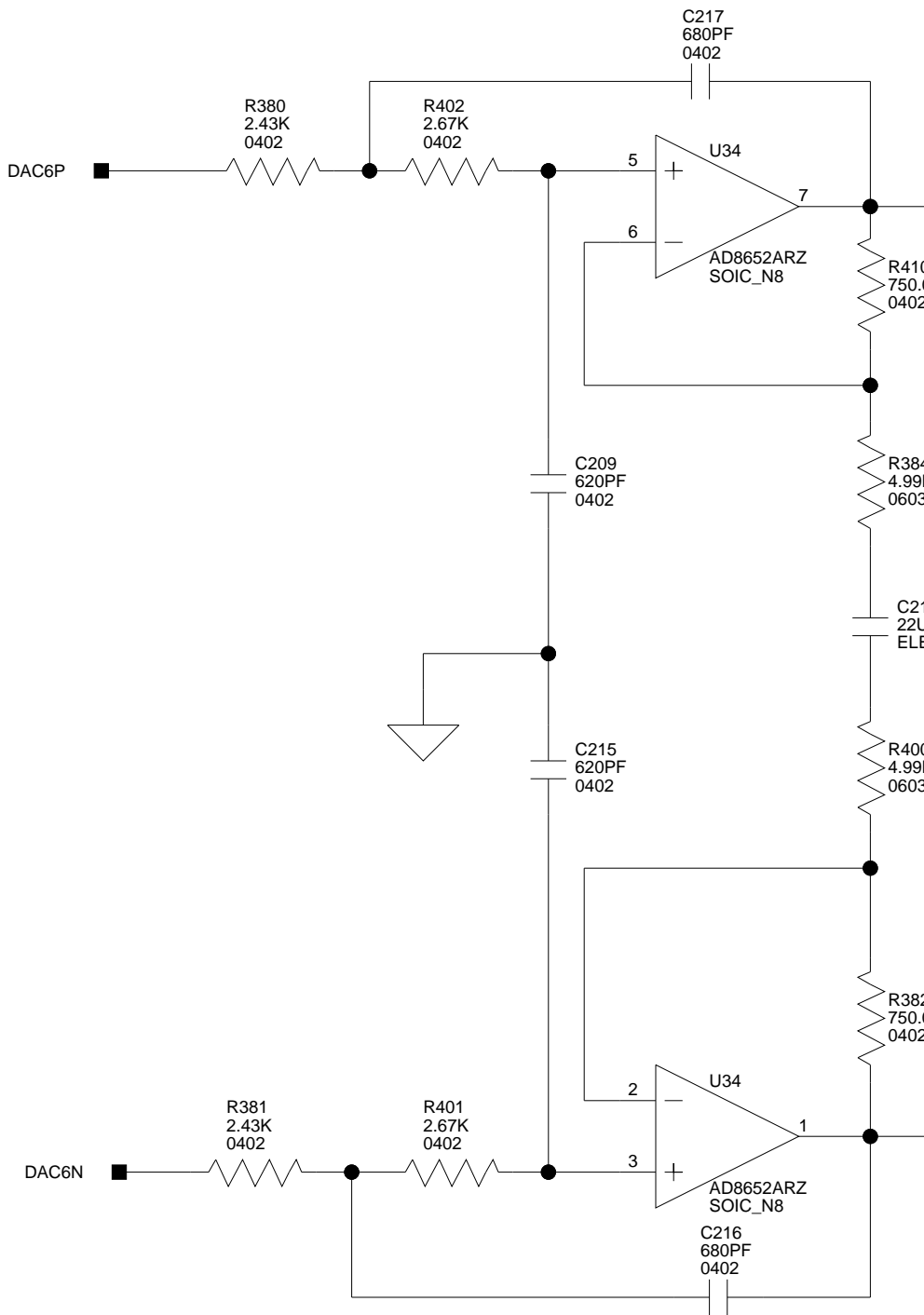

3

4

A

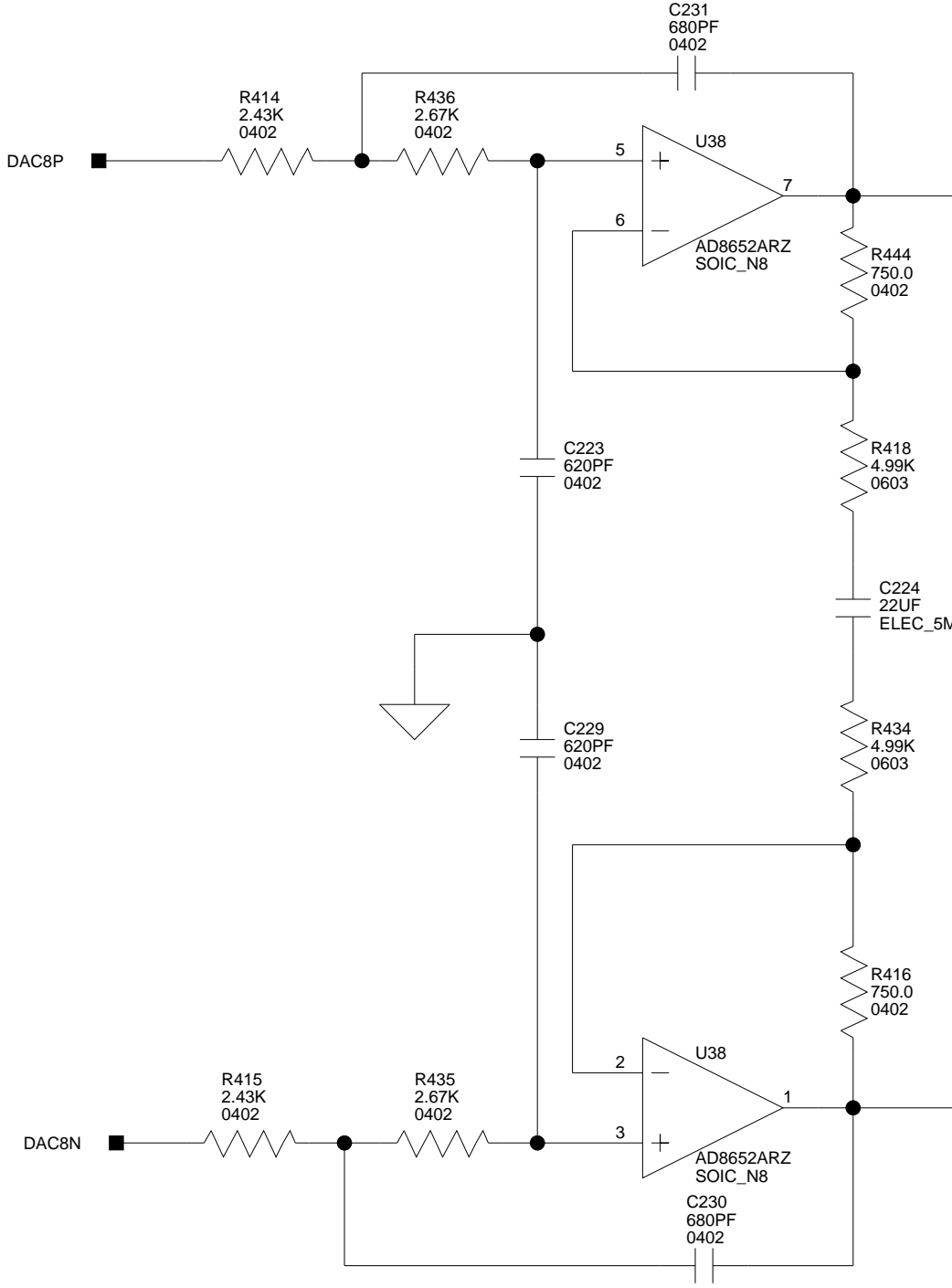

3

4

A

| | | | |
|---------|-------------------|-------|-----|
| DAI_P2 | AD1939_SOFT_RESET | SW1.2 | ON |
| DAI_P3 | LED4 | SW1.3 | ON |
| DAI_P4 | LED5 | SW1.4 | ON |
| DAI_P5 | ASDATA1 | SW1.5 | ON |
| DAI_P6 | ASDATA2 | SW1.6 | ON |
| DAI_P7 | ABCLK | SW1.7 | ON |
| DAI_P8 | ALRCLK | SW1.8 | ON |
| DAI_P9 | DSDATA4 | SW2.1 | ON |
| DAI_P10 | DSDATA3 | SW2.2 | ON |
| DAI_P11 | DSDATA2 | SW2.3 | ON |
| DAI_P12 | DSDATA1 | SW2.4 | ON |
| DAI_P13 | DBCLK | SW2.5 | OFF |
| DAI_P14 | DLRCLK | SW2.6 | OFF |
| DAI_P15 | LED6 | SW2.7 | ON |
| DAI_P16 | LED7 | SW2.8 | ON |
| DAI_P17 | LED8 | SW7.1 | ON |
| DAI_P18 | SPDIF_IN | SW7.2 | ON |
| DAI_P19 | PB3 | SW7.3 | ON |
| DAI_P20 | PB4 | SW7.4 | ON |

NOTE: SHUTTING OFF ANY OF THE SWITCHES FOR EXPANSION USE WILL CAUSE LOSS OF FUNCTIONALITY TO THE RESPECTIVE PERIPHERAL ON THE EZ-BOARD.

| DSP PIN NAME | PERIPHERAL NET CONNECTED TO | CONNECTED VIA SWITCH | SWITCH DEFAULT |
|--------------|-----------------------------|----------------------|----------------|
| DPI_P1 | SPI_MOSI | SW3.1 | ON |
| DPI_P2 | SPI_MISO | SW3.2 | ON |
| DPI_P3 | SPI_CLK | SW3.3 | ON |
| DPI_P4 | AD1939_CS | SW3.4 | ON |
| DPI_P5 | SPI_CS | SW3.5 | ON |
| DPI_P6 | LED1 | SW3.6 | ON |
| DPI_P7 | TEMP_SDA | SW3.7 | ON |
| DPI_P8 | TEMP_SCK | SW3.8 | ON |
| DPI_P9 | UART_TX | SW14.1 | ON |
| DPI_P10 | UART_RX | SW14.2 | ON |
| DPI_P11 | UART_RTS | SW14.3 | OFF |
| DPI_P12 | UART_CTS | SW14.4 | OFF |
| DPI_P13 | LED2 | SW14.5 | ON |
| DPI_P14 | LED3 | SW14.6 | ON |

NOTE: SHUTTING OFF ANY OF THE SWITCHES FOR EXPANSION USE WILL CAUSE LOSS OF FUNCTIONALITY TO THE RESPECTIVE PERIPHERAL ON THE EZ-BOARD.

| |
|---------|
| DS |
| N |
| M |
| M |
| FLAG |
| FLAG |
| FLAG2 |
| FLAG3/ |
| NOTE: S |
| W |
| P |

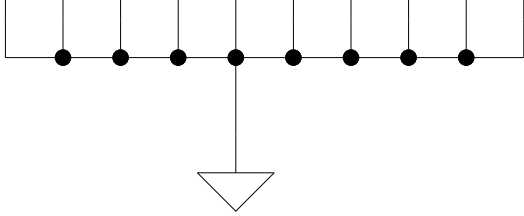

3

4

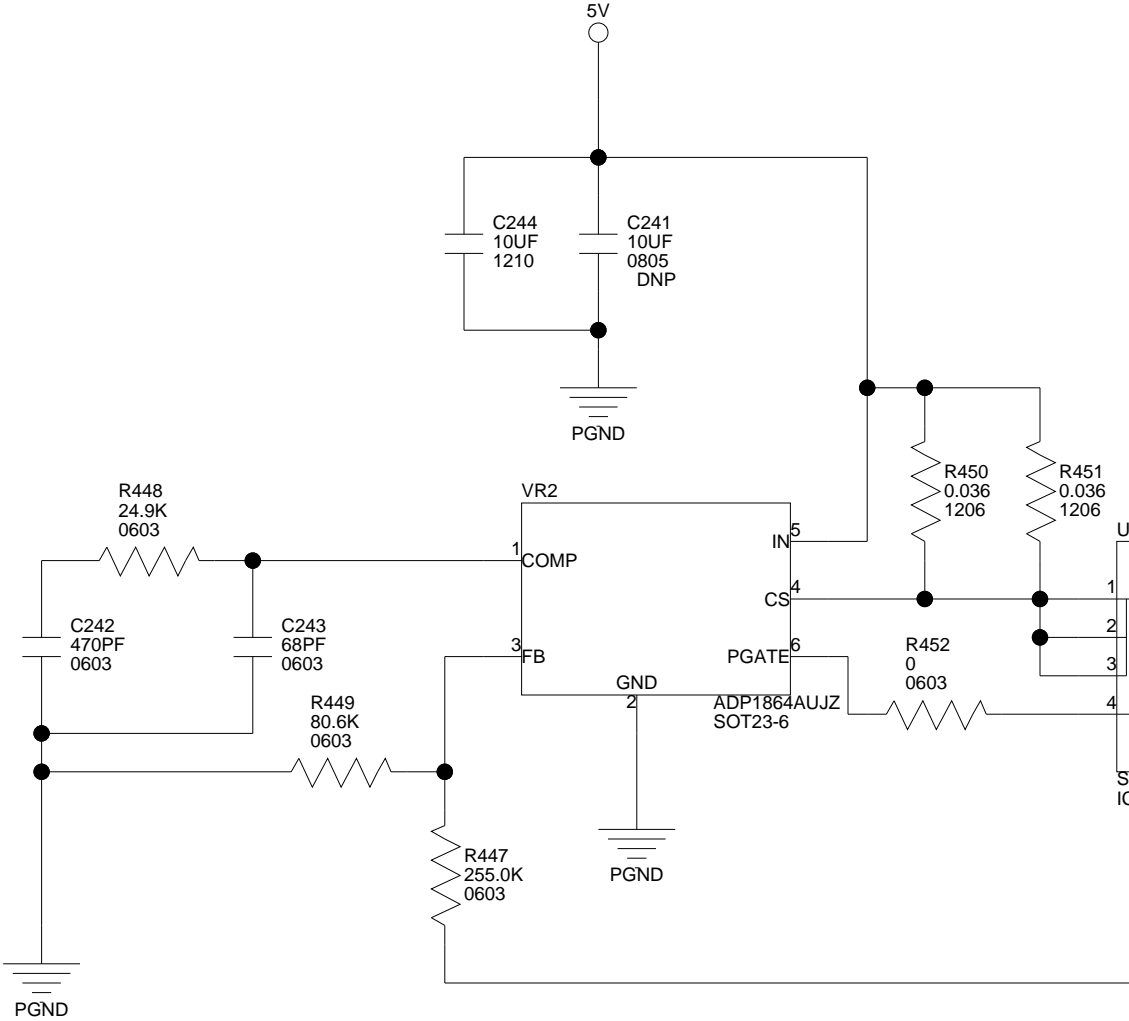

A

I INDEX

A

- ABCLK signal, [1-20](#), [2-3](#), [2-8](#)
- AD1939 codec, [1-19](#)
 - DAI connections, [2-3](#), [2-8](#), [2-9](#), [2-14](#)
 - DPI connections, [2-5](#), [2-9](#)
- AD1939_CS signal, [2-9](#)
- ALRCLK signal, [1-20](#), [2-8](#)
- analog audio interface, *See* [audio](#)
- analog-to-digital converters (ADCs), *See* [AD1939 codec](#)
- architecture, of this EZ-Board, [2-2](#)
- ASDATA1-2 signals, [2-3](#), [2-8](#)
- async control enable switch (SW13), [1-15](#), [1-18](#), [1-23](#), [2-6](#), [2-12](#), [2-13](#)
- audio
 - codec, *See also* [AD1939 codec](#)
 - interface, [1-19](#)
 - left select switch (SW15), [2-14](#)
 - left select switch (SW18), [2-16](#)
 - loopback switches (SW24-25), [2-19](#)
 - RCA connectors (J4-5), [1-18](#), [1-19](#), [2-27](#)
 - right select switch (SW16), [2-15](#)
 - right select switch (SW17), [2-15](#)

B

- bill of materials, [A-1](#)
- board design database, [1-27](#)
- board schematic (ADSP-21469), [B-1](#)

boot

- modes, [2-10](#)
- mode select switch (SW4), [1-15](#), [1-16](#), [1-17](#), [2-10](#)

C

- configuration, of this EZ-Board, [1-3](#)
- connectors
 - diagram of locations, [2-25](#)
 - J1 (expansion interface II), [1-25](#), [2-26](#)
 - J2 (RS-232), [2-26](#)
 - J3 (link port 1), [1-17](#), [1-24](#), [2-17](#), [2-26](#)
 - J4 (RCA), [1-18](#), [1-19](#), [2-27](#)
 - J5 (RCA), [1-18](#), [1-19](#), [2-27](#)
 - J6 (S/PDIF in), [2-27](#)
 - J7 (S/PDIF out), [2-27](#)
 - J8 (headphones), [1-20](#), [2-28](#)
 - P10 (MLB), [2-29](#)
 - P12 (link port 0), [1-17](#), [2-17](#), [2-30](#)
 - P13 (VDD_DDR2 power), [2-30](#)
 - P14 (VDDINT power), [2-30](#)
 - P15 (VDDEXT power), [2-30](#)
 - P16 (5.0V wall adaptor), [1-2](#), [1-9](#), [1-23](#), [2-31](#)
 - P1 (JTAG), [1-9](#), [1-23](#), [2-28](#)
 - P2 (expansion interface II), [1-25](#), [2-28](#)
 - P5-7 (DMAX land grid array), [1-24](#), [2-29](#)
 - P8-9 (diff in/out), [2-29](#)
 - ZP1 (debug agent), [2-31](#)

Index

contents, of this EZ-Board package, [1-2](#)
core voltage, [2-3](#)

D

DAI_P1-2 pins, [2-3](#)
DAI_P15-17 pins, [2-3](#), [2-23](#)
DAI_P19-20 pins, [1-23](#), [2-3](#)
DAI_P3-4 pins, [2-3](#), [2-23](#)
DAI_P5-14 pins, [2-3](#)
DB25 connector, [2-14](#), [2-15](#), [2-16](#)
DBCLK signal, [1-20](#), [2-4](#), [2-9](#)
debug agent connector (ZP1), [2-31](#)
default configuration, of this EZ-Board, [1-3](#)
differential on/out connectors (P8-9), [2-29](#)
digital audio interface (DAI)
 connections, [2-3](#)
 data transfer from codec, [1-19](#)
 LED connections, [2-23](#)
 SW1 switch, [2-8](#)
 SW2 switch, [2-8](#)
 SW7 switch, [1-18](#), [1-23](#), [2-11](#), [2-12](#)
digital peripheral interface (DPI)
 connections, [2-5](#)
 LED connections, [2-23](#)
 SPI memory connections, [1-16](#)
 SW14 switch, [1-20](#), [2-5](#), [2-13](#)
 SW3 switch, [1-16](#), [2-9](#)
digital-to-analog converters (DACs), *See*
 AD1939 codec
DLRCLK signal, [1-20](#), [2-4](#), [2-9](#)
double data rate (DDR2) memory, [xii](#),
 [1-14](#), [2-3](#)
DPI_13-14 pins, [2-23](#)
DPI_P6 pin, [2-23](#)
DSDATA1-4 signals, [2-4](#), [2-9](#)
DSP clock config switch (SW5), [2-11](#)

E

evaluation license
 CCES, [1-11](#)
example programs, [1-27](#)
expansion interface II
 J1 connector, [1-25](#), [2-26](#)
 P2 connector, [1-25](#), [2-28](#)
external memory, [1-13](#), [1-14](#)

F

features, of this EZ-Board, [xii](#)
FLAG0 pin, [1-23](#), [2-6](#), [2-13](#)
FLAG1 pin, [1-23](#), [2-6](#), [2-13](#)
FLAG2 pin, [1-23](#), [2-6](#), [2-13](#)
FLAG3 pin, [2-6](#), [2-13](#)
FLAG4 pin, [2-13](#)
FLASH_CS signal, [2-6](#), [2-13](#)
flash WP jumper (JP1), [2-21](#)

G

general-purpose IO pins (GPIO), [1-21](#),
 [2-12](#)

H

headphones
 enable switch (SW23), [1-20](#), [2-19](#)
 out connector (J8), [2-28](#)

I

installation, of this EZ-Board, [1-3](#), [1-9](#)
 CCES, [1-5](#)
Integrated Interchip Sound (I2C) mode,
 [1-19](#)
internal memory space, [1-13](#)
IO voltage, [2-3](#)
IRQ0-2 pins, [1-23](#), [2-6](#), [2-13](#)

J

J3 (link port 0) connector, [1-17](#), [1-24](#),
[2-17](#), [2-26](#)

J8 (headphones) connector, [1-20](#)

JTAG, [2-17](#)

interface, [1-23](#)

J3 connector, [1-17](#)

P1 connector, [1-9](#), [1-23](#), [2-28](#)

SW19-22 switches, [1-24](#), [2-17](#)

jumpers

diagram of locations, [2-20](#)

JP1 (flash WP), [2-21](#)

JP2 (S/PDIF loopback), [2-21](#)

JP3 (UART RTS/CTS), [2-21](#)

JP4 (UART loopback), [2-21](#)

P13 (VDDINT power), [1-26](#)

P14 (VDDEXT power), [1-26](#)

P15 (VDD_DDR2 power), [1-26](#)

L

land grid array connectors (P5-7), [1-24](#),
[2-29](#)

LEDs

diagram of locations, [2-22](#)

connections, [1-22](#)

LED10 (reset), [2-23](#)

LED11 (thermal limit), [1-18](#), [2-24](#)

LED1-8 (DAI, DPI), [2-23](#)

LED1 (DPI_P6, SW3), [2-5](#), [2-9](#)

LED2 (DPI_P13, SW14), [2-5](#), [2-14](#)

LED3 (DPI_14, SW14), [2-5](#), [2-14](#)

LED4 (DAI_P3, SW1), [1-9](#), [2-3](#), [2-8](#)

LED5 (DAI_P4, SW1), [2-3](#), [2-8](#)

LED6 (DAIP15, SW2), [2-4](#), [2-9](#)

LED7 (DAI_16, SW2), [2-4](#), [2-9](#)

LED8 (DAI_P17, SW7), [2-4](#), [2-11](#)

LED9 (power), [2-23](#)

license restrictions, [1-12](#)

link port

cables, [1-24](#), [2-17](#), [2-26](#), [2-27](#), [2-30](#)

interface, [xiii](#), [1-16](#)

M

master input clock (MCLK), [1-19](#)

media local bus (MLB) connector (P10),
[2-29](#)

memory map, of this EZ-Board, [1-13](#)

MS0-1 select lines, [1-15](#), [2-6](#), [2-13](#)

MS2-3 select lines, [1-23](#), [2-6](#), [2-13](#)

multi-processor configuration, [2-17](#)

N

notation conventions, [xx](#)

O

oscilloscope, [1-26](#)

P

P12 (link port 0) connector, [1-17](#), [1-24](#),
[2-17](#), [2-30](#)

package contents, [1-2](#)

parallel flash memory, [xii](#), [1-15](#), [2-6](#), [2-12](#)

PB1-2, [2-6](#), [2-13](#)

PB3-4, [2-12](#)

POST (power-on-self test) program, [1-15](#),
[1-26](#)

power

5V wall adaptor (P16), [1-2](#), [1-9](#), [1-23](#),
[2-31](#)

LED (LED9), [2-23](#)

measurements, [1-26](#)

product information, [xviii](#)

product overview, [xii](#)

push buttons

connections, [1-23](#), [2-6](#)

SW8-11 (IO) switches, [1-23](#), [2-12](#)

Index

R

RCA audio connector

J4, 1-18, 1-19, 2-27

J5, 1-19, 2-27

reset

LED (LED10), 2-23

push button (SW12), 2-12

RS-232 connector (J2), 2-26

S

schematic, of ADSP-21469 EZ-Board, B-1

SDRAM interface, 1-14

serial clock signal (SCK), 1-17

serial data signal (SDA), 1-17

serial peripheral interconnect (SPI) ports,

See SPI interface

signal routing units

SRU2 (DPI interface), 2-4

SRU (DAI interface), 2-3

single-processor configuration, 2-17

SOFT_RESET signal, 2-8

SPDIF_IN signal, 1-18, 2-11

S/PDIF interface

connections, 1-18, 2-3

in connector (J6), 2-27

loopback jumper (JP2), 2-21

out connector (J7), 2-27

SPDIF_OUT signal, 1-18, 2-8

SPI_CLK signal, 2-5, 2-9

SPI_CS signal, 2-5, 2-9

SPI interface, *xiii*, 1-16

SPI_MISO signal, 2-5, 2-9

SPI_MOSI signal, 2-5, 2-9

SRAM memory, 1-13

standalone debug agent, *xi*, 1-9, 1-12, 1-14, 1-23

startup, of this EZ-Board

CCES, 1-5

SW12 (reset) push button, 2-12

SW13 (async control enable), 1-15, 1-18, 1-23, 2-6, 2-12, 2-13

SW14 (DPI 9-14 enable) switch, 1-20, 2-5, 2-13

SW15 (audio left select) switch, 2-14

SW16 (audio right select) switch, 2-15

SW17 (audio right select) switch, 2-15

SW18 (audio left select) switch, 2-16

SW19-22 (JTAG) switches, 1-24, 2-17

SW1 (DAI 1-8 enable) switch, 1-18, 2-3, 2-8

SW23 (headphone enable) switch, 1-20, 2-19

SW24-25 (audio loopback) switches, 2-19

SW2 (DAI 9-16 enable) switch, 2-8

SW3 (DPI 1-8 enable) switch, 1-16, 2-5, 2-9

SW4 (boot mode select) switch, 1-15, 1-16, 1-17, 2-10

SW5 (DSP clock config), 2-11

SW7 (DAI 17-20 enable) switch, 1-18, 1-23, 2-11, 2-12

SW8-11 (IO) push buttons, 1-23, 2-12

switches, diagram of locations, 2-7

system architecture, of this EZ-Board, 2-2

T

technical support, *xvi*

TEMP_SCK signal, 2-5, 2-10

TEMP_SDA signal, 2-5, 2-10

temp sensor interface, *xiii*, 1-17, 2-6, 2-10, 2-24

thermal limit LED (LED11), 2-24

time-division multiplexed (TDM) mode, 1-19

TIMEXP pin, 2-13

U

UART

- interface connections, [1-20](#)
- loopback jumper (JP4), [2-21](#)
- RTS/CTS jumper (JP3), [2-21](#)

UART_CTS signal, [1-21](#), [2-5](#), [2-14](#), [2-21](#)

UART_RTS signal, [1-21](#), [2-5](#), [2-14](#), [2-21](#)

UART_RX signal, [1-21](#), [2-5](#), [2-13](#)

UART_TX signal, [1-21](#), [2-5](#), [2-13](#)

universal asynchronous receiver

transmitter, *See* UART

USB monitor LED (LED4), [1-9](#)

V

VDD_DDR2

- power connectors (P13), [2-30](#)
- voltage domain, [1-26](#)

VDDEXT

- power connector (P15), [2-30](#)
- voltage domain, [1-26](#)

VDDINT

- power connector (P14), [2-30](#)
- voltage domain, [1-26](#)

VisualDSP++ environment, [1-10](#)

voltage planes, [1-25](#), [2-30](#)

X-ON Electronics

Largest Supplier of Electrical and Electronic Components

Click to view similar products for [Development Boards & Kits - Other Processors](#) category:

Click to view products by [Analog Devices](#) manufacturer:

Other Similar products are found below :

[EVB-MEC1418MECC](#) [20-101-1252](#) [C29XPCIE-RDB](#) [CC-ACC-18M433](#) [MAX1464EVKIT](#) [RTE510Y470TGB00000R](#)
[RTK0EN0001D01001BZ](#) [MAXQ622-KIT#](#) [YR0K505231S000BE](#) [YR0K50571MS000BE](#) [YQB-R5F1057A-TB](#) [QB-R5F104PJ-TB](#) [CC-](#)
[ACC-ETHMX](#) [OV-7604-C7-EVALUATION-BOARD](#) [SK-AD02-D62Q1747TB](#) [SK-BS01-D62Q1577TB](#) [ST7MDT1-EMU2](#) [GROVE BASE](#)
[KIT FOR RASPBERRY PI](#) [RTK5572TKCS00000BE](#) [CAB M-M\(40-17-RAINBOW\)](#) [CY8CKIT-143A](#) [RASPBERRY PI PICO](#) [EK-](#)
[MPC5744P](#) [KITAURIXTC234TFTTOBO1](#) [ENW89854AXKF](#) [ENWF9201AVEF](#) [QB-R5F104LE-TB](#) [LV18F V6 64-80-PIN TQFP MCU](#)
[CARD EMPTY](#) [LV-24-33 V6 44-PIN TQFP MCU CARD EMPTY](#) [LV-24-33 V6 64-PIN TQFP MCU CARD EMPTY](#) [LV-24-33 V6 80-PIN](#)
[TQFP 1 MCU CARD EMPTY](#) [32X32 RGB LED MATRIX PANEL - 6MM PITCH](#) [3.3 - 5 VTRANSLATOR](#) [READY FOR XMEGA](#)
[CASING \(WHITE\)](#) [RELAY4 BOARD](#) [ETHERNET CONNECTOR](#) [RFID CARD 125KHZ - TAG](#) [RFID READER](#) [RFM12B-DEMO](#)
[MAROON](#) [3G CLICK \(FOR EUROPE AND AUSTRALIA\)](#) [MAX232](#) [MAX3232 BOARD](#) [ARTY S7-50](#) [THREE-AXIS](#)
[ACCELEROMETER BOARD](#) [TINKERKIT HALL SENSOR](#) [TOUCHPANEL](#) [TOUCHPANEL CONTROLLER](#) [MIKROBOARD FOR AVR](#)
[WITH ATMEGA128](#) [MIKROBOARD FOR PSOC WITH CY8C27643](#)