

ADSP-BF526 EZ-Board® Evaluation System Manual

Revision 1.2, July 2012

Part Number
82-000208-01

Analog Devices, Inc.
One Technology Way
Norwood, Mass. 02062-9106



Copyright Information

© 2012 Analog Devices, Inc., ALL RIGHTS RESERVED. This document may not be reproduced in any form without prior, express written consent from Analog Devices, Inc.

Printed in the USA.

Disclaimer

Analog Devices, Inc. reserves the right to change this product without prior notice. Information furnished by Analog Devices is believed to be accurate and reliable. However, no responsibility is assumed by Analog Devices for its use; nor for any infringement of patents or other rights of third parties which may result from its use. No license is granted by implication or otherwise under the patent rights of Analog Devices, Inc.

Trademark and Service Mark Notice

The Analog Devices logo, Blackfin, CrossCore, EngineerZone, EZ-Board, EZ-Extender, Lockbox, and VisualDSP++ are registered trademarks of Analog Devices, Inc.

All other brand and product names are trademarks or service marks of their respective owners.

Regulatory Compliance

The ADSP-BF526 EZ-Board is designed to be used solely in a laboratory environment. The board is not intended for use as a consumer end product or as a portion of a consumer end product. The board is an open system design which does not include a shielded enclosure and therefore may cause interference to other electrical devices in close proximity. This board should not be used in or near any medical equipment or RF devices.

The ADSP-BF526 EZ-Board has been certified to comply with the essential requirements of the European EMC directive 2004/108/EC and therefore carries the “CE” mark.

The ADSP-BF526 EZ-Board has been appended to Analog Devices, Inc. EMC Technical File (EMC TF) referenced **DSPTOOLS1**, issue 2 dated June 4, 2008 and was declared CE compliant by an appointed Notified Body (No.0673) as listed below.

Notified Body Statement of Compliance: Z600ANA2.030 dated June 4, 2008.

Issued by: Technology International (Europe) Limited
60 Shrivenham Hundred Business Park
Shrivenham, Swindon, SN6 8TY, UK



The EZ-Board evaluation system contains ESD (electrostatic discharge) sensitive devices. Electrostatic charges readily accumulate on the human body and equipment and can discharge without detection. Permanent damage may occur on devices subjected to high-energy discharges. Proper ESD precautions are recommended to avoid performance degradation or loss of functionality. Store unused EZ-Boards in the protective shipping package.



CONTENTS

PREFACE

Product Overview	xiii
Purpose of This Manual	xvi
Intended Audience	xvi
Manual Contents	xvii
What's New in This Manual	xvii
Technical Support	xviii
Supported Processors	xix
Product Information	xix
Analog Devices Web Site	xix
EngineerZone	xx
Related Documents	xxi
Notation Conventions	xxi

Contents

USING THE ADSP-BF526 EZ-BOARD

Package Contents	1-3
Default Configuration	1-3
CCES Install and Session Startup	1-5
Session Startup	1-6
VisualDSP++ Install and Session Startup	1-9
Session Startup	1-10
CCES Evaluation License	1-12
VisualDSP++ Evaluation License	1-13
Lockbox Key Security Features	1-13
Memory Map	1-14
SDRAM Interface	1-16
Parallel Flash Memory Interface	1-17
NAND Flash Interface	1-18
SPI Interface	1-19
Parallel Peripheral Interface (PPI)	1-20
Rotary Encoder Interface	1-20
Ethernet Interface	1-21
Audio Interface	1-22
USB OTG Interface	1-23
UART Interface	1-24

RTC Interface	1-26
LEDs and Push Buttons	1-26
JTAG Interface	1-28
Land Grid Array	1-29
Expansion Interface II	1-29
Power Architecture	1-30
Power Setup	1-33
Power Saving Features	1-35
Power Measurements	1-36
Power-On-Self Test	1-37
Board Design Database	1-37
Example Programs	1-37

ADSP-BF526 EZ-BOARD HARDWARE REFERENCE

System Architecture	2-2
Programmable Flags	2-3
Push Button and Switch Settings	2-9
Boot Mode Select Switch (SW1)	2-10
SPORT0A ENBL Switches/I2C ENBL (SW2 and SW7)	2-11
Gauge Signals Switch (SW4)	2-11
Rotary Encoder with Momentary Switch (SW5)	2-11
Flash Enable Switch (SW6)	2-12
MIC Gain Switch (SW9)	2-12

Contents

Audio LPBK (Loopback) Switch (SW10)	2-13
ETH Mode/Flash CS Switch (SW11)	2-13
ETH Enable Switch (SW12)	2-14
Rotary/NAND Enable Switch (SW13)	2-14
UART Setup Switch (SW14)	2-15
Programmable Flag Push Buttons (SW15 and SW19)	2-15
Power-Down and Wake Push Buttons (SW16–17)	2-15
Reset Push Button (SW18)	2-16
GPIO Enable Switch (SW20)	2-16
SPORT1 Enable (SW21)	2-18
Battery Switch (SW22)	2-18
Jumpers	2-19
UART Loopback Jumper (JP2)	2-20
UART Enable Jumper (JP3)	2-20
LED Enable Jumper (JP5)	2-20
MIC Select Jumper (JP6)	2-21
CFG WP Jumper (JP7)	2-21
EXP 5V Select Jumper (JP8)	2-21
VR7 Enable Jumper (JP9)	2-21
SENSE2 Select Jumper (JP10)	2-22
RST/ETH LED Jumper (JP11)	2-22
UART SD Jumper (JP14)	2-23
CHG GPIO Jumper (JP15)	2-23
OTP Flag Enable Jumper (JP16)	2-23

CHG Control Jumper (JP17)	2-24
VDDEXT Power Jumper (P11)	2-25
VDDMEM Power Jumper (P12)	2-25
VDDINT Power Jumper (P13)	2-25
ETH PWR Jumpers (P21–22)	2-25
R274 JMP Jumper (P23)	2-26
BATT Installed Jumper (P25)	2-26
LEDs	2-27
Ethernet LEDs (LED1–2)	2-28
GPIO LEDs (LED3–5)	2-28
Reset LED (LED7)	2-28
Batt GD LED (LED8)	2-28
Batt Low LED (LED9)	2-29
Charging LED (LED10)	2-29
Connectors	2-30
Expansion Interface II Connector (J1)	2-31
RS-232 Connector (J2)	2-31
Dual Audio Connectors (J3–4)	2-31
Ethernet Connector (J5)	2-32
Battery Holder (J6)	2-32
JTAG Connector (P1)	2-32
Expansion Interface II Connectors (P2 and P4)	2-33
Expansion Interface II Connector (P3)	2-33
DMAX Land Grid Array Connectors (P5–7)	2-33

Contents

USB OTG Connector (P8)	2-34
Host Interface Connector (P9)	2-34
Power Connector (P14)	2-35
Battery Connector (P24)	2-35
Standalone Debug Agent Connector (ZP1)	2-35

ADSP-BF526 EZ-BOARD BILL OF MATERIALS

ADSP-BF526 EZ-BOARD SCHEMATIC

INDEX

PREFACE

Thank you for purchasing the ADSP-BF526 EZ-Board[®], Analog Devices, Inc. evaluation system for Blackfin[®] processors.

Blackfin processors embody a type of embedded processor designed specifically to meet the computational demands and power constraints of today's embedded audio, video, and communications applications. They deliver breakthrough signal-processing performance and power efficiency within a reduced instruction set computing (RISC) programming model.

Blackfin processors support a media instruction set computing (MISC) architecture. This architecture is the natural merging of RISC, media functions, and digital signal processing (DSP) characteristics. Blackfin processors deliver signal-processing performance in a microprocessor-like environment.

Based on the Micro Signal Architecture (MSA), Blackfin processors combine a 32-bit RISC instruction set, dual 16-bit multiply accumulate (MAC) DSP functionality, and eight-bit video processing performance that had previously been the exclusive domain of very-long instruction word (VLIW) media processors.

The evaluation board is designed to be used in conjunction with the CrossCore[®] Embedded Studio (CCES) and VisualDSP++[®] development environments to test the capabilities of the ADSP-BF526 Blackfin processors. The development environment aids advanced application code development and debug, such as:

- Create, compile, assemble, and link application programs written in C++, C, and assembly
- Load, run, step, halt, and set breakpoints in application programs
- Read and write data and program memory
- Read and write core and peripheral registers
- Plot memory

Access to the ADSP-BF526 processor from a personal computer (PC) is achieved through a USB port or an external JTAG emulator. The USB interface of the standalone debug agent gives unrestricted access to the processor and evaluation board's peripherals. Analog Devices JTAG emulators offer faster communication between the host PC and target hardware. To learn more about Analog Devices emulators and processor development tools, go to <http://www.analog.com/dsp/tools>.

The ADSP-BF526 EZ-Board provides example programs to demonstrate the product capabilities.

Product Overview

The board features:

- Analog Devices ADSP-BF526 Blackfin processor
 - Core performance up to 400 MHz
 - External bus performance up to 80 MHz
 - 208-pin BGA package
 - 25 MHz crystal
- Programmable VDDINT core power
 - Analog Devices AD5258 TWI digital potentiometer
 - Analog Devices ADP1715 low dropout linear regulator
- Battery-powered operation
 - 950 mAh lithium ion battery
 - Analog Devices ADP2291 battery charge circuit
 - Benchmarq BQ27500 fuel gauge for battery monitoring
- Mobile synchronous dynamic random access memory (SDRAM)
 - Micron MT48H32M16 – 64 MB (8M x 16 bits x 4 banks)
- Parallel flash memory
 - Numonyx M58WR032KB – 32 Mb (2M x 16 bits)
- NAND flash memory
 - Numonyx NAND02 – 2 Gb

Product Overview

- SPI flash memory
 - SST SST25WF040 – 4 Mb
- Analog audio interface
 - ADI SSM2603 low-power audio codec
 - One stereo LINE OUT jack
 - One headphone LINE IN
 - One input MIC jack
 - One input stereo LINE IN jack
- Ethernet interface
 - SMSC LAN8700 PHY device
 - 10-BaseT and 100-BaseTX Ethernet controller
 - Auto-MDIX
- Thumbwheel
 - Panasonic EVQ-WKA001 rotary encoder
- Universal asynchronous receiver/transmitter (UART)
 - ADM1385 RS-232 line driver/receiver
 - DB9 female connector

- LEDs
 - Nine LEDs: one board reset (red), three general-purpose (amber), one PHY link (amber), one PHY activity (green), one battery charging (amber), one battery low (amber), and one battery good (green)
- Push buttons
 - Five push buttons: one reset, two programmable flags with debounce logic, wake and sleep with debounce logic
- Expansion interface II™:
 - Next generation of the expansion interface design, provides access to most of the ADSP-BF526 processor signals
- Land grid array
 - Easy probing of all port pins and most EBIU signals
- Other features
 - JTAG ICE 14-pin header
 - USB on-the-go (OTG) connector
 - Host interface connector
 - Blackfin and SDRAM power measurement jumpers

For information about the hardware components of the EZ-Board, refer to [Chapter 2, “ADSP-BF526 EZ-Board Hardware Reference”](#).

Purpose of This Manual

The *ADSP-BF526 EZ-Board Evaluation System Manual* provides instructions for installing the product hardware (board). The text describes operation and configuration of the board components and provides guidelines for running your own code on the ADSP-BF526 EZ-Board. Finally, a schematic and a bill of materials are provided as a reference guide for future designs.

Intended Audience

The primary audience for this manual is a programmer who is familiar with Analog Devices processors. This manual assumes that the audience has a working knowledge of the appropriate processor architecture and instruction set.

Programmers who are unfamiliar with Analog Devices processors can use this manual, but should supplement it with other texts that describe your target architecture. For the locations of these documents, see [“Related Documents”](#).

Programmers who are unfamiliar with CCES or VisualDSP++ should refer to the online help and user’s manuals.

Manual Contents

The manual consists of:

- Chapter 1, “[Using The ADSP-BF526 EZ-Board](#)” on page 1-1
Describes EZ-Board functionality from a programmer’s perspective and provides an easy-to-access memory map.
- Chapter 2, “[ADSP-BF526 EZ-Board Hardware Reference](#)” on page 2-1
Provides information on the EZ-Board hardware components.
- Appendix A, “[ADSP-BF526 EZ-Board Bill Of Materials](#)” on page A-1
Provides a list of components used to manufacture the EZ-Board.
- Appendix B, “[ADSP-BF526 EZ-Board Schematic](#)” on page B-1
Provides resources for board-level debugging, can be used as a reference guide.

What’s New in This Manual

This is revision 1.2 of the *ADSP-BF526 EZ-Board Evaluation System Manual*. The manual has been updated to include CCES information. In addition, modifications and corrections based on errata reports against the previous manual revision have been made.

For the latest version of this manual, please refer to the Analog Devices Web site.

Technical Support

You can reach Analog Devices processors and DSP technical support in the following ways:

- Post your questions in the processors and DSP support community at EngineerZone®:
<http://ez.analog.com/community/dsp>
- Submit your questions to technical support directly at:
<http://www.analog.com/support>
- E-mail your questions about processors, DSPs, and tools development software from **CrossCore Embedded Studio** or **VisualDSP++**:

Choose **Help > Email Support**. This creates an e-mail to processor.tools.support@analog.com and automatically attaches your **CrossCore Embedded Studio** or **VisualDSP++** version information and `license.dat` file.

- E-mail your questions about processors and processor applications to:
processor.support@analog.com or
processor.china@analog.com (Greater China support)
- In the **USA only**, call **1-800-ANALOGD** (1-800-262-5643)
- Contact your Analog Devices sales office or authorized distributor. Locate one at:
www.analog.com/adi-sales

- Send questions by mail to:
Processors and DSP Technical Support
Analog Devices, Inc.
Three Technology Way
P.O. Box 9106
Norwood, MA 02062-9106
USA

Supported Processors

This evaluation system supports Analog Devices ADSP-BF526 Blackfin embedded processors.

Product Information

Product information can be obtained from the Analog Devices Web site and the online help system.

Analog Devices Web Site

The Analog Devices Web site, www.analog.com, provides information about a broad range of products—analogue integrated circuits, amplifiers, converters, and digital signal processors.

To access a complete technical library for each processor family, go to http://www.analog.com/processors/technical_library. The manuals selection opens a list of current manuals related to the product as well as a link to the previous revisions of the manuals. When locating your manual title, note a possible errata check mark next to the title that leads to the current correction report against the manual.

Product Information

Also note, [myAnalog](#) is a free feature of the Analog Devices Web site that allows customization of a Web page to display only the latest information about products you are interested in. You can choose to receive weekly e-mail notifications containing updates to the Web pages that meet your interests, including documentation errata against all manuals.

[myAnalog](#) provides access to books, application notes, data sheets, code examples, and more.

Visit [myAnalog](#) to sign up. If you are a registered user, just log on. Your user name is your e-mail address.

EngineerZone

EngineerZone is a technical support forum from Analog Devices. It allows you direct access to ADI technical support engineers. You can search FAQs and technical information to get quick answers to your embedded processing and DSP design questions.

Use EngineerZone to connect with other DSP developers who face similar design challenges. You can also use this open forum to share knowledge and collaborate with the ADI support team and your peers. Visit <http://ez.analog.com> to sign up.

Related Documents

For additional information about the product, refer to the following publications.

Table 1. Related Processor Publications



Title	Description
<i>ADSP-BF522/ADSP-BF523/ADSP-BF524/ ADSP-BF525/ADSP-BF526/ADSP-BF527 Blackfin Embedded Processor Data Sheet</i>	General functional description, pinout, and timing of the processor
<i>ADSP-BF52x Blackfin Processor Hardware Reference</i>	Description of internal processor architecture and all register functions
<i>Blackfin Processor Programming Reference</i>	Description of all allowed processor assembly instructions

Notation Conventions

Text conventions used in this manual are identified and described as follows.

Example	Description
Close command (File menu)	Titles in reference sections indicate the location of an item within the development environment's menu system (for example, the Close command appears on the File menu).
{this that}	Alternative required items in syntax descriptions appear within curly brackets and separated by vertical bars; read the example as <i>this</i> or <i>that</i> . One or the other is required.
[this that]	Optional items in syntax descriptions appear within brackets and separated by vertical bars; read the example as an optional <i>this</i> or <i>that</i> .
[this,...]	Optional item lists in syntax descriptions appear within brackets delimited by commas and terminated with an ellipse; read the example as an optional comma-separated list of <i>this</i> .

Notation Conventions

Example	Description
.SECTION	Commands, directives, keywords, and feature names are in text with letter gothic font.
<i>filename</i>	Non-keyword placeholders appear in text with italic style format.
	Note: For correct operation, ... A Note provides supplementary information on a related topic. In the online version of this book, the word Note appears instead of this symbol.
	Caution: Incorrect device operation may result if ... Caution: Device damage may result if ... A Caution identifies conditions or inappropriate usage of the product that could lead to undesirable results or product damage. In the online version of this book, the word Caution appears instead of this symbol.
	Warning: Injury to device users may result if ... A Warning identifies conditions or inappropriate usage of the product that could lead to conditions that are potentially hazardous for the devices users. In the online version of this book, the word Warning appears instead of this symbol.

1 USING THE ADSP-BF526 EZ-BOARD

This chapter provides specific information to assist you with development of programs for the ADSP-BF526 EZ-Board evaluation system.

The following topics are covered.

- “Package Contents” on page 1-3
- “Default Configuration” on page 1-3
- “CCES Install and Session Startup” on page 1-5
- “VisualDSP++ Install and Session Startup” on page 1-9
- “CCES Evaluation License” on page 1-12
- “VisualDSP++ Evaluation License” on page 1-13
- “Lockbox Key Security Features” on page 1-13
- “Memory Map” on page 1-14
- “SDRAM Interface” on page 1-16
- “Parallel Flash Memory Interface” on page 1-17
- “NAND Flash Interface” on page 1-18
- “SPI Interface” on page 1-19
- “Parallel Peripheral Interface (PPI)” on page 1-20
- “Rotary Encoder Interface” on page 1-20

- “Ethernet Interface” on page 1-21
- “Audio Interface” on page 1-22
- “USB OTG Interface” on page 1-23
- “UART Interface” on page 1-24
- “RTC Interface” on page 1-26
- “LEDs and Push Buttons” on page 1-26
- “JTAG Interface” on page 1-28
- “Land Grid Array” on page 1-29
- “Expansion Interface II” on page 1-29
- “Power Architecture” on page 1-30
- “Power Setup” on page 1-33
- “Power Saving Features” on page 1-35
- “Power Measurements” on page 1-36
- “Power-On-Self Test” on page 1-37
- “Board Design Database” on page 1-37
- “Example Programs” on page 1-37

For information about the graphical user interface, including boot loading, target options, and other facilities of the EZ-Board system, refer to the online help.

For more information about the ADSP-BF526 Blackfin processor, see documents referred to at [“Related Documents”](#).

Package Contents

Your ADSP-BF526 EZ-Board evaluation system package contains the following items.

- ADSP-BF526 EZ-Board
- Universal 5.0V DC power supply
- Ethernet patch cable
- Two 3.5 mm male-to-male audio cables
- Two mini USB 2.0 cables for USB on-the-go (OTG)

If any item is missing, contact the vendor where you purchased your EZ-Board or contact Analog Devices, Inc.

Default Configuration

The EZ-Board evaluation system contains ESD (electrostatic discharge) sensitive devices. Electrostatic charges readily accumulate on the human body and equipment and can discharge without detection. Permanent damage may occur on devices subjected to high-energy discharges. Proper ESD precautions are recommended to avoid performance degradation or loss of functionality. Store unused EZ-Boards in the protective shipping package.



The ADSP-BF526 EZ-Board is designed to run outside your personal computer as a standalone unit. You do not have to open your computer case.

When removing the EZ-Board from the package, handle the board carefully to avoid the discharge of static electricity, which can damage some components. [Figure 1-1](#) show the default jumper and switch settings, connector locations, and LEDs used in installation. Confirm that your board in the default configuration before using the board.

Default Configuration

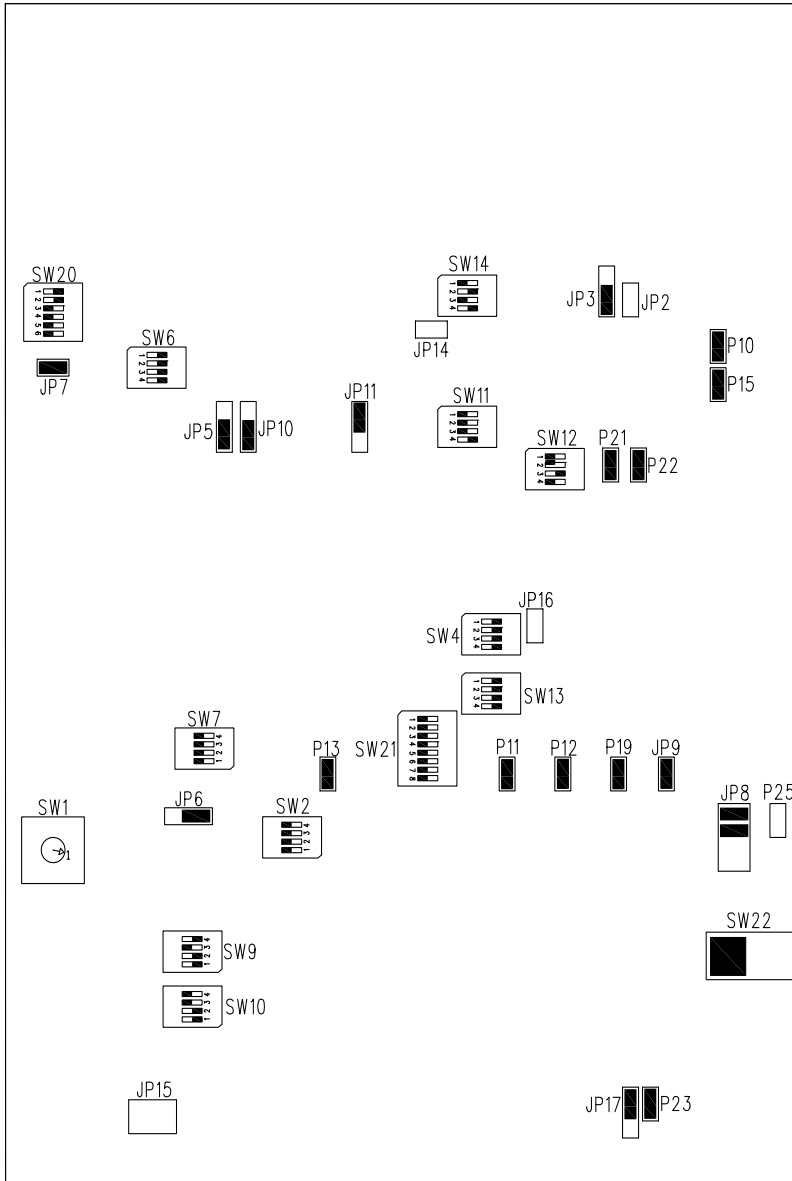

Figure 1-1. Default EZ-Board Hardware Setup

CCES Install and Session Startup

For information about CCES and to download the software, go to www.analog.com/CCES. A link for the ADSP-BF526 EZ-KIT Lite Board Support Package (BSP) for CCES can be found at <http://www.analog.com/Blackfin/EZKits>.

Follow these instructions to ensure correct operation of the product software and hardware.

Step 1: Connect the EZ-KIT Lite board to a personal computer (PC) running CCES using one of two options: an Analog Devices emulator or via the debug agent.

Using an Emulator:

1. Plug one side of the USB cable into the USB connector of the emulator. Plug the other side into a USB port of the PC running CCES.
2. Attach the emulator to the header connector P1 (labeled JTAG) on the EZ-Board.

Using the standalone Debug Agent:

1. Attach the standalone debug agent to connectors P1 (labeled JTAG) and ZP1 of the EZ-Board.
2. Plug one side of the USB cable into the USB connector of the debug agent P4. Plug the other side of the cable into a USB port of the PC running CCES.

CCES Install and Session Startup

Step 2: Attach the provided cord and appropriate plug to the power adaptor.

1. Plug the jack-end of the power adaptor into the power connector P14 (labeled 5.0V) on the EZ-Board.
2. Plug the other side of the power adaptor into a power outlet. The power LED (labeled LED4) is lit green when power is applied to the board.
3. Power the emulator (if used). Plug the jack-end of the assembled power adaptor into the emulator and plug the other side of the power adaptor into a power outlet. The enable/power is lit green when power is applied.

Step 3 (if connected through the debug agent): Verify that the yellow USB monitor LED (labeled LED2) and the green power LED (labeled LED1) on the debug agent are both on. This signifies that the board is communicating properly with the host PC and ready to run CCES.

Session Startup

It is assumed that the CrossCore Embedded Studio software is installed and running on your PC.



Note: If you connect the board or emulator first (before installing CCES) to the PC, the Windows driver wizard may not find the board drivers.

1. Navigate to the CCES environment via the **Start** menu.

Note that CCES is not connected to the target board.

2. Use the system configuration utility to connect to the EZ-Board.

If a debug configuration exists already, select the appropriate configuration and click **Apply and Debug** or **Debug**. Go to step 8.

To create a debug configuration, do one of the following:

- Click the down arrow next to the little bug icon, select **Debug Configurations**
- Choose **Run > Debug Configurations**.

The **Debug Configuration** dialog box appears.

3. Select **CrossCore Embedded Studio Application** and click  (New launch configuration).

The **Select Processor** page of the **Session Wizard** appears.

4. Ensure **Blackfin** is selected in **Processor family**. In **Processor type**, select **ADSP-BF526**. Click **Next**.

The **Select Connection Type** page of the **Session Wizard** appears.

5. Select one of the following:
 - For standalone debug agent connections, **EZ-Board** and click **Next**.
 - For emulator connections, **Emulator** and click **Next**.

The **Select Platform** page of the **Session Wizard** appears.



CCES Install and Session Startup

6. Do one of the following:
 - For standalone debug agent connections, ensure that the selected platform is **ADSP-BF526 EZ-Board** via Debug Agent.
 - For emulator connections, choose the type of emulator that is connected to the board.
7. Click **Finish** to close the wizard.

The new debug configuration is created and added to the program(s) to load list.

8. In the **Program(s) to load** section, choose the program to load when connecting to the board. If not loading any program upon connection to the target, do not make any changes.

Note that while connected to the target, there is no way to choose a program to download. To load a program once connected, terminate the session.

 To delete a configuration, go to the **Debug Configurations** dialog box and select the configuration to delete. Click  and choose **Yes** when asked if you wish to delete the selected launch configuration. Then **Close** the dialog box.

 To disconnect from the target board, click the terminate button (red box) or choose **Run > Terminate**.

To delete a session, choose **Target > Session > Session List**. Select the session name from the list and click **Delete**. Click **OK**.

VisualDSP++ Install and Session Startup

For information about VisualDSP++ and to download the software, go to www.analog.com/VisualDSP.

There are two options to connect the EZ-Board hardware to a personal computer (PC) running VisualDSP++: via an Analog Devices emulator or via a standalone debug agent module. The standalone debug agent allows a debug agent to interface to the ADSP-BF526 EZ-Board. The standalone debug agent is shipped with the kit.

To connect the EZ-Board to a PC via an emulator:

1. Set up the EZ-Board for either battery power or wall/USB power; see “Power Setup” on page 1-33.
2. Attach the emulator header to connector P1 (labeled JTAG) on the back side of the EZ-Board.
3. Depending on the power source for the EZ-Board, do one of the following.
 - Turn ON switch SW22 (battery)
 - Plug the 5V wall adaptor into connector P14 (labeled 5.0V)
4. Plug the mini plug of the provided USB cable into connector P8 (labelled USB OTG). Plug the standard USB plug into a USB port of the PC running VisualDSP++.

VisualDSP++ Install and Session Startup

To connect the EZ-Board to a PC via a standalone debug agent:



The debug agent can be used only when power is supplied from the wall adaptor.

1. Attach the standalone debug agent to connectors P1 (labeled JTAG) and ZP1 on the backside of the EZ-Board, watching for the keying pin of P1 to connect correctly. Plug the 5V adaptor into connector P14 (labeled 5.0V).
2. Plug one side of the provided USB cable into the USB connector (ZP1) of the standalone debug agent. Plug the other side of the cable into a USB port of the PC running VisualDSP++.

The other USB connector on the ADSP-BF526 EZ-Board (labelled USB OTG, P8) is for applications use.

3. Verify that the yellow USB monitor LED on the standalone debug agent (LED4, located near the USB connector) is lit. This signifies that the board is communicating properly with the host PC and ready to run VisualDSP++.

Session Startup

1. If you are running VisualDSP++ for the first time, navigate to the VisualDSP++ environment via the **Start > Programs** menu. The main window appears. Note that VisualDSP++ is not connected to any session. Skip the rest of this step to step 2.

If you have run VisualDSP++ previously, the last opened session appears on the screen. You can override the default behavior and force VisualDSP++ to start a new session by pressing and holding down the **Ctrl** key while starting VisualDSP++. Do not release the **Ctrl** key until the **Session Wizard** appears on the screen. Go to step 3.

2. To connect to a new EZ-Board session, start **Session Wizard** by selecting one of the following.
 - From the **Session** menu, **New Session**.
 - From the **Session** menu, **Session List**. Then click **New Session** from the **Session List** dialog box.
 - From the **Session** menu, **Connect to Target**.
3. The **Select Processor** page of the wizard appears on the screen. Ensure **Blackfin** is selected in **Processor family**. In **Choose a target processor**, select **ADSP-BF526**. Click **Next**.
4. The **Select Connection Type** page of the wizard appears on the screen. For standalone debug agent connections, select **EZ-Board** and click **Next**. For emulator connections select **Emulator**, and click **Next**.
5. The **Select Platform** page of the wizard appears on the screen. For standalone debug agent connections, ensure that the selected platform is **ADSP-BF526 EZ-Board via Debug Agent**. For emulator connections, choose the type of emulator that is connected. Specify your own **Session name** for the session or accept the default name.

The session name can be a string of any length; although, the box displays approximately 32 characters. The session name can include space characters. If you do not specify a session name, VisualDSP++ creates a session name by combining the name of the selected platform with the selected processor. The only way to change a session name later is to delete the session and open a new session.

Click **Next**.

CCES Evaluation License

6. The **Finish** page of the wizard appears on the screen. The page displays your selections. Check the selections. If you are not satisfied, click **Back** to make changes; otherwise, click **Finish**. VisualDSP++ creates the new session and connects to the EZ-Board. Once connected, the main window's title is changed to include the session name set in step 5.



To disconnect from a session, click the disconnect button  or select **Session > Disconnect from Target**.

To delete a session, select **Session > Session List**. Select the session name from the list and click **Delete**. Click **OK**.

CCES Evaluation License

The ADSP-BF526 EZ-Board software is part of the Board Support Package (BSP) for the Blackfin ADSP-BF52x family. The EZ-Board is a licensed product that offers an unrestricted evaluation license for 90 days after activation. Once the evaluation period ends, the evaluation license becomes permanently disabled. If the evaluation license is installed but not activated, it allows 10 days of unrestricted use and then becomes disabled. The license can be re-enabled by activation.

An evaluation license can be upgraded to a full license. Licenses can be purchased from:

- Analog Devices directly. Call (800) 262-5645 or 781-937-2384 or go to:
<http://www.analog.com/buyonline>.
- Analog Devices, Inc. local sales office or authorized distributor. To locate one, go to:
<http://www.analog.com/salesdir/continent.asp>.

-  The EZ-Board hardware must be connected and powered up to use CCES with a valid evaluation or full license.

VisualDSP++ Evaluation License

The ADSP-BF526 EZ-Board installation is part of the VisualDSP++ installation. The EZ-Board is a licensed product that offers an unrestricted evaluation license for the first 90 days. Once the initial unrestricted 90-day evaluation license expires:

- VisualDSP++ restricts a connection to the ADSP-BF526 EZ-Board via the USB port of the standalone debug agent interface only. Connections to simulators and emulation products are no longer allowed.
- The linker restricts a user's program to 20 KB of memory for code space with no restrictions for data space.

-  To avoid errors when opening VisualDSP++, the EZ-KIT Lite hardware must be connected and powered up. This is true for using VisualDSP++ with a valid evaluation or full license.

Lockbox Key Security Features

Blackfin processors feature Lockbox[®] secure technology: hardware-enabled code security and content protection for one-time programmable (OTP) memory. Customers purchasing Blackfin processors can program their own customer public key in OTP.

The ADSP-BF526 EZ-Boards are evaluation boards with the Lockbox key pre-programmed and publicly documented—the burden of key generation and OTP programming of public keys is removed from the customer. Customers can still program other areas of OTP memory on the ADSP-BF526 EZ-Board. Analog Devices publicly document the

Memory Map

EZ-Board's public and private key pair for customer evaluation and support of the Lockbox feature, all while avoiding any keys information exchange. As a result, there is no confidentiality associated with the Lockbox key on EZ-Boards.

To demonstrate Lockbox features using an EZ-Board, you must use the keys that are provided pre-programmed on your EZ-Board.

-  Use the EZ-Board key pair to generate a demo and then provide the keys to the demo users. Note that the EZ-Board cannot be used to secure any confidential information. If you wish to create a demo with confidential keys, you must build your own Blackfin board and personalize it with your own keys.

Memory Map

The ADSP-BF526 processor has internal static random access memory (SRAM) used for instructions and data storage. See [Table 1-1](#). The internal memory details can be found in the *ADSP-BF52x Blackfin Processor Hardware Reference*.

The ADSP-BF526 EZ-Board includes four types of external memory: synchronous dynamic random access memory (SDRAM), serial peripheral interconnect (SPI), parallel flash, and NAND flash. See [Table 1-2](#). For more information about a specific memory type, go to the respective section in this chapter.

Table 1-1. EZ-Board Internal Memory Map

Start Address	Content
0xEF00 0000	BOOT ROM (32K BYTE)
0xEF00 8000 0xFE80 0000 0xFE82 0000 0xFF40 0000 0xFF40 4000 0xFF40 8000 0xFF50 0000 0xFF50 4000 0xFF50 8000 0xFF60 0000 0xFF60 4000 0xFF60 8000 0xFF60 C000 0xFF61 0000 0xFF61 4000 0xFF70 0000 0xFF70 1000	Reserved
0xFF80 0000	L1 DATA BANKA SRAM (16K BYTE)
0xFF80 4000	L1 DATA BANKA SRAM/CACHE (16K BYTE)
0xFF80 8000	Reserved
0xFF90 0000	L1 DATA BANKB SRAM (16K BYTE)
0xFF90 4000	L1 DATA BANKB SRAM/CACHE (16K BYTE)
0xFF90 8000	Reserved
0xFFA0 0000	L1 INSTRUCTION BANKA LOWER SRAM (16K BYTE)
0xFFA0 4000	L1 INSTRUCTION BANKA UPPER SRAM (16K BYTE)
0xFFA0 8000	L1 INSTRUCTION BANKB LOWER SRAM (16K BYTE)
0xFFA0 C000	Reserved
0xFFA1 0000	L1 INSTRUCTION SRAM/CACHE (16K BYTE)

SDRAM Interface

Table 1-1. EZ-Board Internal Memory Map (Cont'd)

Start Address	Content
0xFFA1 4000 0xFFA1 8000 0xFFA1 C000 0xFFA2 0000 0xFFA2 4000	Reserved
0xFFB0 0000	L1 SCRATCHPAD SRAM (4K BYTE)
0xFFB0 1000	Reserved
0xFFC0 0000	SYSTEM MMR REGISTERS
0xFFE0 0000	CORE MMR REGISTERS

Table 1-2. EZ-Board External Memory Map

Start Address	End Address	Content
0x0000 0000	0x03FF FFFF	SDRAM bank 0 (SDRAM)
0x2000 0000	0x200F FFFF	ASYNC memory bank 0 (flash)
0x2010 0000	0x201F FFFF	ASYNC memory bank 1 (flash)
0x2020 0000	0x202F FFFF	ASYNC memory bank 2 (flash)
0x2030 0000	0x203F FFFF	ASYNC memory bank 3 (flash)
0x2040 0000	0xEEFF FFFF	Reserved

SDRAM Interface

The ADSP-BF526 processor connects to a 64 MB Micron MT48H32M16-75 chip through the external bus interface unit (EBIU). The SDRAM chip can operate at a maximum clock frequency of 80 MHz, which is the ADSP-BF526 processor limitation when operating VDDEXT at 1.8V.

With a CCES or VisualDSP++ session running and connected to the EZ-Board via the USB standalone debug agent, the SDRAM registers are

configured automatically each time the processor is reset. The values are used whenever SDRAM is accessed through the debugger (for example, when viewing memory windows or loading a program).

To disable the automatic setting of the SDRAM registers, do one of the following:

- CCES users, choose **Target > Settings > Target Options** and clear the **Use XML reset values** check box.
- VisualDSP++ users, choose **Settings > Target Options** and clear the **Use XML reset values** check box.

For more information on changing the reset values, refer to the online help.

An example program is included in the EZ-Board installation directory to demonstrate how to setup and access the SDRAM interface. For more information on how to initialize the registers after a reset, search the online help for “reset values”.

Parallel Flash Memory Interface

The parallel flash memory interface of the ADSP-BF526 EZ-Board contains a 4 MB (2M x 16 bits) 1.8V Numonyx M58WR032KB chip. Flash memory connects to the 16-bit data bus and address lines 1 through 19. Chip enable is decoded by the AMS0–3 select lines through NAND and AND gates. The address range for flash memory is 0x2000 0000 to 0x203F FFFF.

Flash memory is pre-loaded with boot code for the blink and power-on-self test (POST) programs. For more information, refer to [“Power-On-Self Test” on page 1-37](#). Flash memory also is preloaded with configuration flash information, which contains board revision, BOM revision, and other data.

NAND Flash Interface

By default, the EZ-Board boots from the 16-bit parallel flash memory. The processor boots from flash memory if the boot mode select switch (SW1) is set to a position of 1 (see “[Boot Mode Select Switch \(SW1\)](#)” on [page 2-10](#)).

Flash memory code can be modified. For instructions, refer to the online help and example program included in the EZ-Board installation directory.

NAND Flash Interface

The ADSP-BF526 processor is equipped with an internal NAND flash controller, which allows the 2 Gb 1.8V ST Micro’s NAND02 device to be attached gluelessly to the processor. NAND flash is attached via the processor’s specific NAND flash control and data lines. NAND flash shares pins with the Ethernet PHY, host connector, and expansion interface II.

The NAND chip enable signal (NDCE#_HOSTD10) can be disconnected from NAND flash by turning SW13.4 (switch 13 position 4) OFF. This ensures that NAND flash is not driving data when HOSTD10 changes state. See “[Rotary/NAND Enable Switch \(SW13\)](#)” on [page 2-14](#) for more information.

The Ethernet PHY (U29) must be disabled in order for NAND flash to function properly. This is accomplished by setting switch SW12 to OFF, OFF, ON, OFF.

For more information about the NAND02 device, refer to the Numonyx Web site: <http://www.numonyx.com>.

An example program is included in the EZ-Board installation directory to demonstrate how to setup and access the NAND flash interface.

SPI Interface

The ADSP-BF526 processor has one serial peripheral interface (SPI) port with multiple chip select lines. The SPI port connects directly to serial flash memory, audio codec, and expansion interface II.

Serial flash memory is a 4 Mb SST SST25WF040 device, which is selected using the `SPISEL1` line of the processor.

SPI flash memory is factory programmed with Das U-Boot—the universal boot loader. Das U-Boot (*U-Boot* for short) is open source firmware for embedded processors, including the ADSP-BF526 Blackfin processors. U-Boot can load files from a variety of peripherals, such as a serial connection, an Ethernet network connection, or flash memories. U-Boot is executed at system reset, which automatically loads up another application (such as the Linux kernel or a stand alone application). U-Boot can parse many types of files on many types of storage devices.

U-Boot is controlled via a serial communications, the default setting is 56700 baud, 8 data bits, No parity, 1 stop bit. See “[RS-232 Connector \(J2\)](#)” on [page 2-31](#) for information on the serial connector.

For more information about U-Boot, refer to the online documentation: <http://docs.blackfin.uclinux.org/doku.php?id=bootloaders:u-boot>.

For U-Boot support on the Blackfin processors, refer to the online help forums:

http://blackfin.uclinux.org/gf/project/u-boot/forum/?action=ForumBrowse&forum_id=51.

SPI flash can be modified. For instructions, refer to the online help, example program included in the EZ-Board installation directory, and U-Boot documentation. U-Boot includes an SPI flash driver and can be used to download a new file over Ethernet or serial connection, and write that to SPI flash.

Parallel Peripheral Interface (PPI)

By default, the EZ-Board boots from the 16-bit flash parallel memory. SPI flash can be selected as the boot source by setting the boot mode select switch (SW1) to position 3 (see “[Boot Mode Select Switch \(SW1\)](#)” on [page 2-10](#)).

Parallel Peripheral Interface (PPI)

The ADSP-BF526 processor provides a parallel peripheral interface (PPI), supporting data widths up to 16 bits. The PPI interface provides three multiplexed frame syncs, a dedicated clock input, and 16 data lines. The full PPI port is accessible on the expansion interface II connector (P3).

The PPI signals connect to multi-function pins; the upper eight data bit signals are configured for the rotary, SPI, UART1, and LED0 interfaces. To use the upper eight PPI data lines at connector P3, change the board as follows: disable rotary switch (SW13 positions 1–3 OFF) and disable the UART1 interface (remove a jumper from JP3). LED0 mimics the PPID8 data pin.

The PPI has a dedicated clock, generated from the expansion interface II. The PPI is not used on the EZ-Board, intended for use on the expansion interface II.

Rotary Encoder Interface

The ADSP-BF526 processor has a built-in, up-down counter with support for a rotary encoder. The three-wire rotary encoder interface connects to the thumbwheel rotary switch (SW13) and expansion interface II connector (P3). The rotary encoder can be turned clockwise for the up function, counter clockwise for the down function, or can be pushed towards the center of the board to clear the counter.

The rotary switch is a two-bit quadrature (gray code) counter with a detent, meaning that both the down signal (CDG) and up signal (CUD)

toggle when the count register increases on a rotation to the right. Upon rotating to the left, CDG and CUD toggle, and the overall count decreases.

If the processor pins are needed for the expansion interface II, disconnect the rotary encoder switch via the four-position rotary/NAND enable switch (SW13). [For more information, see “Rotary/NAND Enable Switch \(SW13\)” on page 2-14.](#)

An example program is included in the EZ-Board installation directory to demonstrate how to set up and access the rotary encoder interface.

Ethernet Interface

The ADSP-BF526 processor has an integrated Ethernet MAC with media independent interface (MII) and reduced media independent interface (RMII), which connects to an external PHY. The EZ-Board provides a SMSC LAN8700 RMII Ethernet PHY with Auto-MDIX, fully compliant with IEEE 802.2/802.2u standards. The SMSC LAN8700 chip supports 10BASE-T and 100BASE-TX operations. The part is attached gluelessly to the processor.

The Ethernet signals are shared with NAND flash; by default, the Ethernet mode is set OFF (SW12 OFF, OFF, ON, OFF). See [“ETH Enable Switch \(SW12\)” on page 2-14](#) for more information.



It is important not to run code that accesses NAND flash while using the Ethernet interface.

The Ethernet mode is set by the SW11 switch and defaults to all capable, auto negotiation with settings OFF, OFF, OFF, ON. See [“ETH Mode/Flash CS Switch \(SW11\)” on page 2-13](#) for more information.

The Ethernet chip is pre-loaded with a MAC address. The MAC address for the EZ-Board is stored in the configuration flash section of the parallel flash memory and can be found on a sticker on the bottom side of the board.

Audio Interface

The PHY portion of the Ethernet chip connects to a Pulse HX1188 magnetics (U28), then to a standard RJ-45 Ethernet connector (J5). [For more information, see “Ethernet Connector \(J5\)” on page 2-32.](#)

Example programs are included in the EZ-Board installation directory to demonstrate how to use the Ethernet interface.

In low-power consumption applications that do not require Ethernet, the P21–22 jumpers can be removed to disconnect the power from the LAN8700 PHY and Ethernet oscillator. [For more information, see “ETH PWR Jumpers \(P21–22\)” on page 2-25.](#)

Audio Interface

The audio interface of the EZ-Board consists of a low-power stereo codec, ADI SSM2603, with an integrated headphone driver and associated passive components. There are two inputs, a stereo line in, and a mono microphone, as well as two outputs, a headphone, and a stereo line out. The codec has integrated stereo analog-to-digital converters (ADCs) and digital-to-analog converters (DACs) and requires minimal external circuitry.

The codec connects to the ADSP-BF526 processor via the processor’s serial port 0A (alternate). The SPORT0A port and 2-wire interface (TWI) are disconnected from the codec by turning switches SW2 and SW7 OFF, which enable SPORT0A on the expansion interface II. See [“SPORT0A ENBL Switches/I2C ENBL \(SW2 and SW7\)” on page 2-11](#) for more information.

The TWI of the ADSP-BF526 processor is used to setup and control the codec. The default TWI address is 0011011. The TWI can be disconnected from the codec by turning positions 3 and 4 of SW2 OFF. Refer to [“SPORT0A ENBL Switches/I2C ENBL \(SW2 and SW7\)” on page 2-11](#) for more information.

Mic gain values of 14 dB, 0 dB, or –6 dB are selectable through the SW9 switch by turning ON position 1, 2, or 3 (respectively). All other positions must be OFF to achieve the desired gain. [For more information, see “MIC Gain Switch \(SW9\)” on page 2-12.](#)

Microphone bias is provided through a low-noise reference voltage. A jumper on positions 2 and 3 of JP6 connects the MICBIAS signal to the audio jack. Placing a jumper on positions 1 and 2 of JP6 connects the bias directly to the mic signal. [For more information, see “MIC Select Jumper \(JP6\)” on page 2-21.](#)

J3 and J4 are 3.5 mm connectors for the audio portion of the board. J4 connects the mic on the top portion and line-in on the bottom. J3 connects the headphone on the top portion and line-out on the bottom. If there is no 3.5 mm cable plugged into the bottom of either J3 or J4, the signals are looped back inside the connector. [For more information, see “Dual Audio Connectors \(J3–4\)” on page 2-31.](#)

For testing, SW10 positions 1 and 2 connect the MICIN signal to either the left or right headphone. Do not connect the left and right to the MICIN signal at the same time—only position 1 or 2 of SW10 should be ON at the same time. [For more information, see “Audio LPBK \(Loopback\) Switch \(SW10\)” on page 2-13.](#) Positions 3 and 4 of SW10 disconnect the line in from line out loopback.

The EZ-Board is shipped with two 3.5 mm cables, which allow you to run the example programs provided in the EZ-Board installation directory and learn about the audio interface.

USB OTG Interface

The ADSP-BF526 processor has a built-in, high-speed USB OTG interface and integrated PHY. The interface connects to a 24 MHz crystal (Y2), has a surge protector, and can be configured as a host or a device. When in

UART Interface

device mode, the USB 5V FET switch (U23) is turned OFF. When in host mode, the ADSP-BF526 EZ-Board can supply 5V to a device, if desired.

 A 5V, 500 mA current can be supplied only when the EZ-Board is powered from the 5V wall source.

The 5V supplied to an external USB device is controlled by the PG13 flag pin of the processor. PG13 must be connected on the board to signal USB_VRSEL through switch SW20. The USB_VRSEL signal controls an Analog Devices ADM869L p-channel FET, which has an active low ON pin. By default, USB_VRSEL is held high or a logic ‘1’ via a pull-up resistor and disconnects the 5V wall supply to VBUS. To set host mode and provide 5V to a device, set SW20 positions 2 and 5 OFF and position 6 ON. This disables push button 2. Note that signal HOSTADDR is shared with push button 2; do not use the push button when controlling the USB_VRSEL signal.

By default, SW20 positions 2, 5, and 6 are ON, OFF, and OFF (respectively) and shut off the p-channel FET (U23). [For more information, see “GPIO Enable Switch \(SW20\)” on page 2-16.](#)

The USB OTG interface has a mini-AB connector (P8); a cable that plugs into P8 is shipped with the EZ-Board.

Use the example programs in the EZ-Board installation directory to learn about the ADSP-BF526 processor’s device and host modes. For more information about the USB interface, refer to the *ADSP-BF52x Blackfin Processor Hardware Reference*.

UART Interface

The ADSP-BF526 processor has two built-in universal asynchronous receiver transmitters (UARTs). UART0–1 share the processor pins with other peripherals on the EZ-Board.

UART1 has full RS-232 functionality via the Analog Devices 3.3V ADM1385 line driver and receiver (U21). The ADSP-BF526 processor is

running at the VDDEXT voltage of 1.8V, requiring a voltage translator (U32) to translate the 1.8V processor signals to the UART 3.3V line transceiver.

The UART1 interface is disconnected from the ADM1385 transceiver by ensuring that no jumper is installed on JP3. The ADM1385 transceiver is shut down by placing a jumper on JP14. The UART1 interface is controlled by the inverted WAKEUP_OUT signal, $\overline{\text{WAKEUP_OUT}}$. To set up $\overline{\text{WAKEUP_OUT}}$, place a jumper on the JP3 positions 1 and 2. A jumper on positions 1 and 2 of JP3 disables the voltage translator, disconnecting the ADM1385 device from the UART1 interface of the processor. This JP3 setting does not shut down the transceiver. For more information on power saving capabilities of the EZ-Board, see [“UART Enable Jumper \(JP3\)” on page 2-20](#) and [“UART SD Jumper \(JP14\)” on page 2-23](#).

SW14 allows the flow control signals to be looped back. See [“UART Setup Switch \(SW14\)” on page 2-15](#) for more information.

When using UART1, do not install jumper JP2. JP2 is a UART loopback jumper and should be installed only when running the POST program. If signals RTS and CTS are needed for flow control, the UART1RTS port pin PF10 can be configured as a general-purpose I/O (GPIO) pin for RTS. The HWAIT port pin PG0 can be used for CTS by setting up the pin accordingly; see [“UART Loopback Jumper \(JP2\)” on page 2-20](#) and [“UART Enable Jumper \(JP3\)” on page 2-20](#) for more information.

UART0 and UART1 are connected to the expansion interface II at connectors P2 and P4. For more information, see [“Expansion Interface II Connectors \(P2 and P4\)” on page 2-33](#).

Example programs are included in the EZ-Board installation directory to demonstrate UART and RS-232 operations.



On the processor, UART1 shares pins with the PPI interface; consequently, do not use UART1 at the same time as the PPI interface. To disable the UART line drive, ensure that JP3 has no jumpers on.

RTC Interface

For more information on the UART interface, refer to the *ADSP-BF52x Blackfin Processor Hardware Reference*.

RTC Interface

The ADSP-BF526 processor has a real-time clock (RTC) and a watchdog timer. Typically, the RTC interface is used to implement a real-time watchdog or a life counter of the time elapsed since the last system reset. The EZ-Board is equipped with a Panasonic CR1632 lithium coin, 3V battery supplying 125 mAh. The 3V battery and 3.3V supply of the board connect to the RTC power pin of the processor. When the EZ-Board is powered, the RTC circuit uses the board power to supply voltage to the RTC pin. When the EZ-Board is not powered, the RTC circuit uses the lithium battery to maintain the power to the RTC pin. After removing the mylar, the battery lasts for about one year with the EZ-Board unpowered.

Example programs are included in the EZ-Board installation directory to demonstrate the RTC features.

 The EZ-Board is shipped with a protective Mylar sheet placed between the coin battery and positive pin of the battery holder. Remove the Mylar sheet before using the RTC in the processor.

For more information on the RTC and watchdog timer, refer to the *ADSP-BF52x Blackfin Processor Hardware Reference*.

LEDs and Push Buttons

The EZ-Board provides two push buttons and three LEDs for general-purpose I/O and two additional push buttons intended for power down and wake functionality, which also can be used as GPIO flag pins.

The three LEDs, labeled LED0 through LED2, are accessed via the PF8, PG11, and PG12 pins of the processor (respectively). For information on how to

program the flag pins, refer to the *ADSP-BF52x Blackfin Processor Hardware Reference*.

LED1 is shared with the HOSTWR# signal, while LED2 is shared with the HOSTACK signal. The LED0 signal is shared with the PPI D8 signal. When using the PPI 16-bit data interface, LED0 mimics PPI D8.

The LED1 and LED2 signals also connect to the expansion interface II (connectors J1, P2, and P4). See [“Expansion Interface II Connector \(J1\)” on page 2-31](#) and [“Expansion Interface II Connectors \(P2 and P4\)” on page 2-33](#) for more information.

The two general-purpose push buttons are labeled PB1 and PB2. The status of each individual button can be read through programmable flag inputs PG0 and PG13. The flag reads ‘1’ when a corresponding switch is being pressed. When the switch is released, the flag reads ‘0’. A connection between the push buttons and processor inputs is established through positions 1 and 2 of the DIP switch, SW20.

Push buttons 1 and 2 of SW20 are used as GPIO signals on the expansion interface II connectors (J1, P2, P4). To use the PG0 and PG13 port pins as GPIO signals on the expansion interface II, turn SW20 positions 1 and 2 OFF.

Push button 1 cannot be used when PG0 is set up to control the charge rate, when charging the battery over USB. To set this up, turn SW20.1 OFF. See [“CHG GPIO Jumper \(JP15\)” on page 2-23](#) for more information.

Push button 2 can be connected to the USB_VRSEL signal by setting switches SW13.2 OFF, SW20.5 OFF, and SW20.6 ON. The USB_VRSEL signal allows the USB OTG interface to power an external USB device with 5V. Push button 2 also can be connected to the OTP_FLAG signal, which is necessary to supply 7V for writing to OTP. To set up the EZ-Board to control the OTP_FLAG signal, set switches SW13.2 OFF, SW20.5 ON, and SW20.6 OFF. Push button 2 is shared with signal HOSTADDR. See [“USB OTG Interface” on page 1-23](#) and [“GPIO Enable Switch \(SW20\)” on page 2-16](#) for more information.

JTAG Interface

For a power down interrupt, signal `LED2_HOSTACK` is wired to `SW20.3` (GPIO enable switch), which allows a push button (`SW16`) to drive an interrupt to the ADSP-BF526 processor. The `PG12` port pin of the processor should be set up as a GPIO pin. Turning switch `SW20.3` ON connects the push button (`SW16`) to the processor. By default, `SW20.3` is OFF.

A wake interrupt can be set up by turning switch `SW20.4` ON and setting the processor's flag pin `PG15` as the wake interrupt. When push button `SW17` (labelled `WAKE`) is pressed, `PG15` receives a low-to-high transition. The `PG15` processor pin is shared with the audio codec (`U31`), Ethernet PHY (`U29`), and `HOSTCE` signal. Do not use these features when using the wake interrupt push button.

An example program is included in the ADSP-BF526 installation directory to demonstrate functionality of the LEDs and push buttons.

JTAG Interface

The JTAG connector (`P1`) allows the standalone debug agent to connect a debug session to the ADSP-BF526 processor. The debug agent operates only when the external 5V wall adaptor is used (`P14`). When operating the EZ-Board from a battery or USB bus power, the debug agent is not powered.

The standalone debug agent can be removed, and an external emulator can be attached to the EZ-Board. Be careful not to damage the connectors when removing the debug agent. The emulator connects to `P1` on the back side of the board. See [“CCES Install and Session Startup” on page 1-5](#) or [“VisualDSP++ Install and Session Startup” on page 1-9](#) for more information.

For more information about emulators, contact Analog Devices or go to: <http://www.analog.com/processors/tools/blackfin>.

Land Grid Array

The ADSP-BF526 EZ-Board has provisions for probing every port pin and the EBIU interface of the processor on connectors P5, P6, and P7. The connector locations are intended for use with a Tektronix DMAX logic analyzer connector, but can be probed with any oscilloscope or logic analyzer. Connectors P5 and P6 require the primary retention posts, while connector P7 can use either the primary or secondary retention post. For pinout information, refer to [“ADSP-BF526 EZ-Board Schematic” on page B-1](#).

For more information on the Tektronix DMAX logic analyzer interface, go to the Tektronix Web site.

Expansion Interface II

The expansion interface II allows an Analog Devices EZ-Extender[®] or a custom-design daughter board to be tested across various hardware platforms that have the same expansion interface.

The expansion interface II implemented on the ADSP-BF526 EZ-Board consists of four connectors, three of which are 0.1 in. shrouded headers (P2–4) and the last of which is a Samtec QMS series header (J1). The connectors contain a majority of the ADSP-BF526 processor signals. For the pinout of the connectors, go to [“ADSP-BF526 EZ-Board Schematic” on page B-1](#). The mechanical dimensions of the expansion connectors can be obtained by contacting [Technical Support](#).

For more information about daughter boards, visit the Analog Devices Web site at: <http://www.analog.com/processors/tools/blackfin>.

Limits to current and interface speed must be taken into consideration when using the expansion interface II. Current for the expansion interface II is sourced from the EZ-Board, therefore, the current should be limited to 1A for 5V and 500 mA for the 1.8V planes. When a battery supplies

Power Architecture

power to the EZ-Board, the expansion interface II 5V current is reduced to 400mA. If more current is required, then a separate power connector and a regulator must be designed on a daughter card. Additional circuitry can add extra loading to signals, decreasing their maximum effective speed.

 Analog Devices does not support and is not responsible for the effects of additional circuitry.

Power Architecture

The ADSP-BF526 EZ-Board has three primary voltage sources, a lithium ion battery (740 mAh), a 5V wall adaptor, and V_{BUS} supplied over a USB cable. There is an OR'ing opamp circuit, which allows the board to draw power from any supply source that has the highest voltage potential. For example, if the battery is turned on while the board is plugged into the 5V wall adaptor (P14), the board runs from the 5V wall adaptor.

The VDDEXT, VDDMEM, and SDRAM power are 1.8V and supplied by an ADP2105 regulator (VR3).

The ADSP-BF526 core voltage, VDDINT, is selected via the I²C interface of the processor. The default is 1.4V. An I²C voltage translator (U39) interfaces the 1.8V signals SDA and SCL of the processor to the AD5258 digital potentiometer (digipot, U34). The digipot sets the feedback resistors for a low drop-out (LDO) regulator ADP1715 (VR5). See the POST example located in the ADSP-BF526 directory of CCES or VisualDSP++ to learn how to change the VDDINT voltage. [Table 1-3](#) shows the appropriate step settings for the digipot and corresponding voltage values.

Table 1-3. Voltage Values

Step Value	Voltage (V)
57	1.10
46	1.15
36	1.20
27	1.25
18	1.30
10	1.35
3	1.40

The 3.3V power for the board is regulated by an ADP2105 converter (VR2).

The 1.8V power for the audio ADI SSM2603 audio codec (U31) is regulated by an ADP1205 device (VR1).

The expansion interface II is equipped with three voltage domains: 5V, 3.3V, and 1.8V. The 1.8V and 3.3V are provided directly through the VR2 and VR3 regulators. The 5V is sourced from the wall adaptor when jumper JP8 is set to positions 1, 2 and 3, 4, and JP9 is ON. The 5V also can be provided by the on-board ADP1611 converter when using the lithium ion battery. To set up the ADP1611 converter (VR7), install jumpers on positions 5, 6 and 7, 8 of JP8 and ensure JP9 is OFF.

To write to the OTP memory inside the processor, turn SW20.2 OFF, SW20.5 ON, and SW20.6 OFF. Also install a jumper on JP16. Now the PG13 flag pin of the processor, when driven high, provides a precise 7.0V for OTP writes. Ensure that the PG13 flag pin is driven low when not writing to the OTP memory: there is a limited amount of time that the OTP circuit can be supplied 7V. Refer to the *ADSP-BF522/523/524/525/526/527 Blackfin Embedded Processor Data Sheet* for more information.

Power Architecture



Leaving JP16 ON when not writing to the OTP memory can damage the processor. See the *ADSP-BF522/523/524/525/526/527 Blackfin Embedded Processor Data Sheet*.

In USB host mode, if the host must provide 5V to a device, the PG13 flag pin must be set low to turn on the p-channel mosfet (U23). To connect PG13 of the processor to the mosfet, set SW20.2 OFF, SW20.5 OFF, and SW20.6 ON.

The lithium ion battery leads are inserted into the P24 connector. The SW22 switch connects the battery to the EZ-Board when SW22 is ON. To change the battery, press in the white tabs and slide out the battery lead.



The EZ-Board is intended to be used at room temperature (approximately 21°C).

An ADP2291 lithium ion battery charger IC charges the 740 mAh battery. The charge rate is selected based on a jumper placement and whether the battery is charging from a wall adaptor or from a USB port. See [Table 1-4](#) for details.

The lithium battery is monitored by the BQ27500 fuel gauge (U38). All battery statistics can be read from the fuel gauge, including time to empty, current voltage, and current consumption rate. SW4 positions 1 and 2 disconnect the fuel gauge LED signals. SW4 positions 3 and 4 disconnect the TWI signals from the processor and fuel gauge. For more information about SW4, refer to [“Gauge Signals Switch \(SW4\)” on page 2-11](#). An example program in the POST directory of the ADSP-BF526 EZ-Board installation demonstrates how to use the fuel gauge.



Change jumper and switch settings only when power is OFF.

Table 1-4. Charge Rate Selection

Mode	WALL	USB	JP17	P23	Resistance	Charge Rate
Full Charge	YES	NO	X ¹	X	OPEN	750 mA
Low	NO	YES	OFF	OFF	32K	100 mA
Medium	NO	YES	2 and 3	X	169K	375 mA
Selectable ²	NO	YES	1 and 2	OFF	32/169K	100/375 mA
Shutdown	NO	YES	OFF	ON	0	NONE
Control Shut-down ³	NO	YES	1 and 2	ON	0/169K	0/375mA

- 1 Any jumper setting has no affect.
- 2 Rate is selectable by the processor's flag: use JP15 to chose the flag pin. Setting the flag high selects 83 mA and setting the flag low selects 375 mA charge rates.
- 3 JP15 needs to be set to positions 1 and 2 (PG0), 3 and 4 (PG11), or 5 and 6 (PG12), selecting the processor port pin to control the selection. See [“CHG GPIO Jumper \(JP15\)” on page 2-23](#) for more information.

Power Setup

The EZ-Board is shipped with the default configuration for 5V power from a wall adaptor or a USB port (see [Table 1-5](#)).



Change jumper and switch settings only when power is OFF.

Table 1-5. 5V Power Settings

Switch/Jumper	5V Setting
JP8	Positions 1 and 2, 3 and 4
JP9	Installed
JP10	Positions 2 and 3
JP15	Uninstalled
P17	Positions 1 and 2

Power Setup

Table 1-5. 5V Power Settings (Cont'd)

Switch/Jumper	5V Setting
P23	OFF
P25	OFF
SW22	OFF

To set up the board for battery operation, the settings in [Table 1-6](#) are a good starting point.

Table 1-6. Battery Power Settings

Switch/Jumper	Battery Setting
JP8 (if 5V needed on the expansion interface II)	Positions 5 and 6, 7 and 8
JP9 (if 5V needed on expansion interface II)	Uninstalled
JP10	Positions 1 and 2
JP15	See Table 1-4
P17	See Table 1-4
P23	OFF; see Table 1-4
P25	ON
SW22	ON

Refer to the individual switch and jumper descriptions for alternate settings.



Note that complying with USB current limitations requires limiting the charging rate and implementation of power saving features.

Power Saving Features

The ADSP-BF526 EZ-Board is designed for low-power application evaluations; use the following settings to enable the board's power saving features.

- Jumper-controlled power savings
 - The Ethernet PHY (SMSC LAN8700) can be totally powered down by removing jumpers P21 and P22.
 - The UART line drivers can be powered down by placing a jumper on JP14 and then removing any jumper from JP3.
 - The reset and Ethernet LED voltage translator can be disabled by removing any jumper from JP11.
 - The GPIO LED's and OTP flag voltage translator can be disabled by removing any jumper from JP5.
- Processor-controlled power savings

The VDDINT regulator (VR5) can be shut down with the EXT_WAKE signal of the processor. EXT_WAKE also controls:

- The OTP flag and LED voltage translator (U3) via JP5
- The Ethernet LED and reset voltage translator (U4) via JP11
- The UART1 voltage translator (U32) via JP3

Refer to the *ADSP-BF52x Blackfin Processor Hardware Reference* for more information about EXT_WAKE; refer to [“Jumpers” on page 2-19](#) for more information about the jumpers.

Power Measurements

- Low-power mode capable ICs of the EZ-Board
 - ADI SSM2603 audio codec (U31)
 - Micron MT48H32M16-75 SDRAM memory (U14)
 - Numonyx M58WR032KB parallel flash (U16)
 - SST 25WF040 SPI flash memory (U6)
 - Numonyx NAND02 flash memory (U15)

Some of the low-power modes are entered by inactivity on-chip select lines. Consult the product data sheets for details.

Power Measurements

Several locations are provided for measuring the current draw from various power planes. Precision 0.1 ohm shunt resistors are available on the VDDINT, VDDEXT, VDDMEM, and SDRAM voltage domains. For current draw measurements, the associated jumper (P13, P11, P12, or P19) should be removed. Once the jumper is removed, the voltage across the resistor can be measured using an oscilloscope. Once voltage is measured, current can be calculated by dividing the voltage by 0.1. For the highest accuracy, a differential probe should be used for measuring voltage across the resistor.

For more information, see [“VDDINT Power Jumper \(P13\)” on page 2-25](#), [“VDDEXT Power Jumper \(P11\)” on page 2-25](#), and [“VDD-MEM Power Jumper \(P12\)” on page 2-25](#).

Power-On-Self Test

The power-on-self-test program (POST) tests all EZ-Board peripherals and validates functionality as well as connectivity to the processor. Once assembled, each EZ-Board is fully tested for an extended period of time with a POST. All EZ-Boards are shipped with the POST preloaded into one of its on-board flash memories. The POST is executed by resetting the board and pressing the proper push button(s). The POST also can be used for reference for a custom software design or hardware troubleshooting. Note that the source code for the POST program is included in the installation directory along with the readme file, which describes how the board is configured to run POST.

 The POST program is only available when using VisualDSP++.

Board Design Database

A .zip file containing all of the electronic information required for the design, layout, fabrication and assembly of the product is available for download from the Analog Devices board design database at:

<http://www.analog.com/board-design-database>.

Example Programs

Example programs are provided with the ADSP-BF526 EZ-KIT Lite to demonstrate various capabilities of the product. The programs are included in the product installation kit and can be found in the `Examples` folder of the installation. Refer to a readme file provided with each example for more information.

CCES users are encouraged to use the example browser to find examples included with the EZ-KIT Lite Board Support Package.

Example Programs

2 ADSP-BF526 EZ-BOARD HARDWARE REFERENCE

This chapter describes the hardware design of the ADSP-BF526 EZ-Board.

The following topics are covered.

- [“System Architecture” on page 2-2](#)
Describes the ADSP-BF526 EZ-Board configuration and explains how the board components interface with the processor.
- [“Programmable Flags” on page 2-3](#)
Shows the locations and describes the programming flags (PFs).
- [“Push Button and Switch Settings” on page 2-9](#)
Shows the locations and describes the push buttons and switches.
- [“Jumpers” on page 2-19](#)
Shows the locations and describes the configuration jumpers.
- [“LEDs” on page 2-27](#)
Shows the locations and describes the LEDs.
- [“Connectors” on page 2-30](#)
Shows the locations and provides part numbers for the on-board connectors. In addition, the manufacturer and part number information is provided for the mating parts.

System Architecture

This section describes the processor's configuration on the EZ-Board (Figure 2-1).

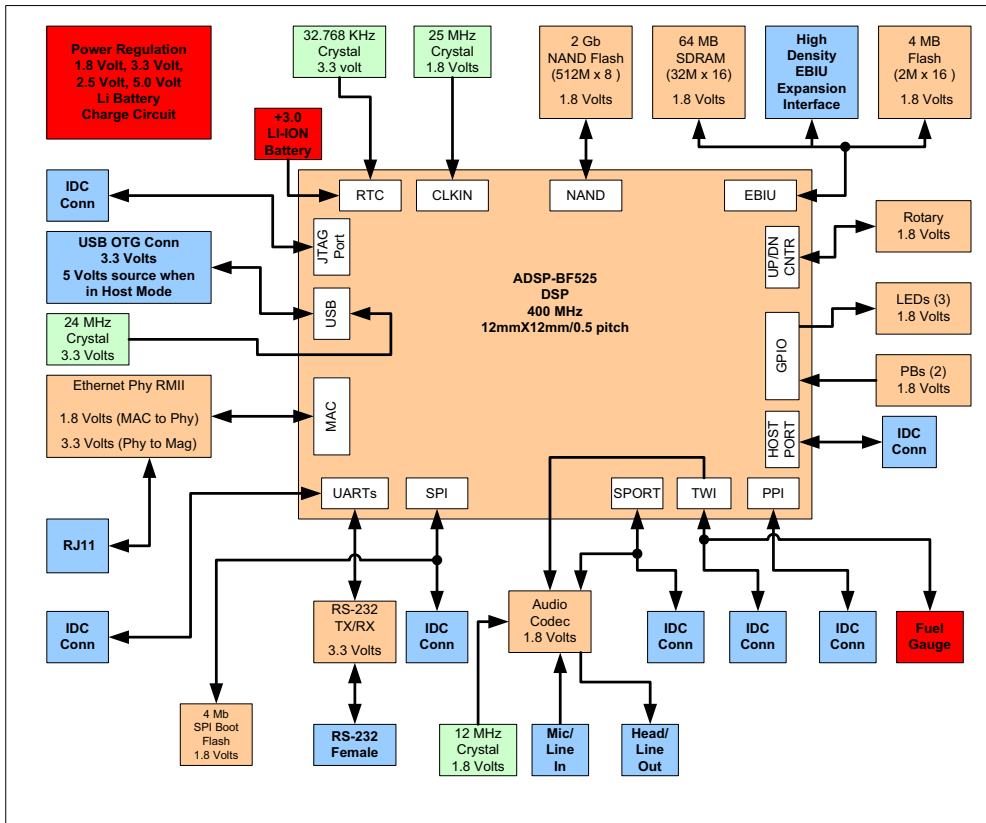

Figure 2-1. System Architecture

This EZ-Board is designed to demonstrate the capabilities of the ADSP-BF526 Blackfin processors. The processor has an I/O voltage of 1.8V. The core voltage of the processor is controlled by an Analog Devices ADP1715 low dropout regulator (LDO) and an Analog Devices AD5258

digipot, which is configurable over the 2-wire interface (TWI) signals. Refer to the power-on-self test (POST) example in the ADSP-BF526 installation directory for information on how to set up the TWI interface.

The core voltage and clock rate can be set on the fly by the processor. The input clock is 25 MHz. A 32.768 kHz crystal supplies the real-time clock (RTC) inputs of the processor. The default boot mode for the processor is external parallel flash boot. See [“Boot Mode Select Switch \(SW1\)”](#) on [page 2-10](#) for information on how to change the default boot mode.

Programmable Flags

The processor has 50 general-purpose input/output (GPIO) signals spread across four ports (PF, PG, PH, and PJ). The pins are multi-functional and depend on the ADSP-BF526 processor setup. The following tables show how the programmable flag pins are used on the EZ-Board.

- PF programmable flag pins in [Table 2-1](#)
- PG programmable flag pins in [Table 2-2](#)
- PH programmable flag pins in [Table 2-3](#)
- PJ programmable flag pins in [Table 2-4](#)

Table 2-1. PF Port Programmable Flag Connections

Processor Pin	Other Processor Function	EZ-Board Function
PF0	PPID0/DR0PRI/ND_D0A	Default: PPID0 on P3.18 via RN1. Land grid array via P7.A.
PF1	PPID1/RFS0/ND_D1A	Default: PPID1 on P3.17 via RN1. Land grid array via P7.A2.
PF2	PPID2/RSCLK0/ND_D2	Default: PPID2 on P3.20 via RN1. Land grid array via P7.A4.
PF3	PPID3/DTOPRI/ND_D3A	Default: PPID3 on P3.19 via RN1. Land grid array via P7.A5.

Programmable Flags

Table 2-1. PF Port Programmable Flag Connections (Cont'd)

Processor Pin	Other Processor Function	EZ-Board Function
PF4	PPID4/TFS0/ND_D4A/ TACLK0	Default: PPID4 on P3.22 via RN1. Land grid array via P7.A10.
PF5	PPID5/TSCLK0/ND_D5A/ TACLK1	Default: PPID5 on P3.21 via RN1. Land grid array via P7.A11.
PF6	PPID6/DT0SEC/ND_D6A/ TACIO	Default: PPID6 on P3.24 via RN1. Land grid array via P7.A13.
PF7	PPID7/DR0SEC/ND_D7A/ TACI1	Default: PPID7 on P3.23 via RN1. Land grid array via P7.A14.
PF8	PPID8/DR1PRI	Default: LED0 via RN2. Expansion interface II (P3.26 (PPID8), P4.14 via SW21.8, land grid array via P7.A16.
PF9	PPID9/RSCLK1/SPISEL6#	Default: PPID9 via RN2. Expansion interface II (P3.25, P4.18) via SW21.7, land grid array via P7.A17.
PF10	PPID10/PRFS1/SPISEL7#	Default: UART1RTS (U21) via U32, SW14.3 and RN2. Expansion interface II (P3.28, P4.20) via SW21.6, land grid array via P7.A17.
PF11	PPID11/TFS1/CZM	Default: CZM rotary (SW5) via SW13.3 and RN2. Expansion interface II (P3.27, P4.19) via SW21.5, land grid array via P7.A20.
PF12	PPID12/DT1PRI/ SPISEL2#/CDG	Default: CDG rotary (SW5) via SW13.2 and RN2. Expansion interface II (P3.30, P4.13) via SW21.4, land grid array via P7.A22.
PF13	PPID13/TSCLK1/ SPISEL3#/CUD	Default: CUD rotary (SW5) via SW13.1 and RN2. Expansion interface II (P3.29, P4.17) via SW21.3, land grid array via P7.A23.
PF14	PPID14/DT1SEC/UART1TX	Default: UAR1TX (U21) via U32 and RN2. Expansion interface II (P3.32, P4.15) via SW21.2, land grid array via P7.A25.
PF15	PPID15/DR1SEC/ UART1RX/TACI3	Default: UAR1RX (U21) via U32, SW14.2 and RN2. Expansion interface II (P3.31, P4.16 via SW21.1, P4.32) via SW21.1, land grid array via P7.A26.

ADSP-BF526 EZ-Board Hardware Reference

Table 2-2. PG Port Programmable Flag Connections

Processor Pin	Other Processor Function	EZ-Board Function
PG0	HWAIT	Default: PB1 via SW21.1 and RN5. UART1 CTS (HWAIT) via U32, SW14.1, host connector P9.12, CHG GPIO JP15.1, expansion interface II (P2.37, P4.37, J1.52), land grid array via P7.B27.
PG1	SPISS#/SPISEL1#	Default: SPI flash (U6) CS via SW11.4 and RN3. Expansion interface II (P2.21, P4.21, P4.26, P2.26), land grid array via P7.B26.
PG2	SPI SCK	Default: SPI flash (U6). Expansion interface II (P2.24, P4.24), land grid array via P7.B9.
PG3	SPIMISO/DROSECA	Default: SPI flash (U6) via RN3. Expansion interface II (P2.16, P2.27, P4.27), land grid array via P7.B23.
PG4	SPIMOSI/DTOSECA	Default: SPI flash (U6). Expansion interface II (P2.15, P2.25, P4.25), land grid array via P7.B24.
PG5	TMR1/PPIFS2/TFS0A	Default: PPIFS2 P3.14. Land grid array via P7.B17.
PG6	DTOPRIA/TMR2/PPIFS3	Default: DTOPRIA codec (U31) via SW7.2. Expansion interface II (P2.13, P3.15), land grid array via P7.B18.
PG7	TMR3/DROPRIA/UART0TX	Default: DROPRIA codec (U31) via SW7.3. Expansion interface II (P2.14, P2.31, P3.36), land grid array via P7.B14.
PG8	TMR4/RFS0A/UART0RX/ TACI4	Default: RFS0A codec (U31) via SW7.4. Expansion interface II (P3.35, P2.20, P2.32), land grid array via P7.B15.
PG9	TMR5/RSCLK0A/TACI5	Default: RSCLK0A codec (U31) via SW2.2. Expansion interface II (P2.18, P3.38), land grid array via P7.B11.
PG10	TMR6/TSCLK0A/TACI6	Default: TSCLK0A codec (U31) via SW2.1. Expansion interface II P2.17, land grid array via P7.B12.

Programmable Flags

Table 2-2. PG Port Programmable Flag Connections (Cont'd)

Processor Pin	Other Processor Function	EZ-Board Function
PG11	TMR7/HOST_WR#	Default: LED1 via U3 and RN5. CHG GPIO JP15.3, host connector P9.4, expansion interface II (J1.51, P2.28, P2.38, P4.28, P4.38), land grid array via P7.B6.
PG12	DMAR1/UART1TXA/ HOST_ACK	Default: LED2 via U3 and RN5. Power down PB via SW20.3, CHG GPIO JP15.5, host connector P9.10, expansion interface II (J1.54, P2.39, P4.39), land grid array via P7.B8.
PG13	DMAR0/UART1RXA/ HOST_ADDR/TACI2	Default: PB2 via SW21.2 and RN5. OTP_FLAG_1P8V via SW20.5, USB_VRSEL via SW20.6, host connector P9.8, expansion interface II (J1.53, P2.40, P4.40), land grid array via P7.B5.
PG14	TSCLK0A/MDC/HOST_RD#	Default: host connector P9.2. MDC PHY (U29) via SW12.2, land grid array via P7.B2.
PG15	TFS0A/MIIPHYINT#/ RMIIMDINT#/HOST_CE#	Default: TFS0A codec (U31) via SW7.1 and RN5 RMIIMDINT# PHY (U29), wake via SW20.4, host connector P9.6, expansion interface II P2.19, land grid array via P7.B3.

Table 2-3. PH Port Programmable Flag Connections

Processor Pin	Other Processor Function	EZ-Board Function
PH0	ND_D0/MIICRS/ RMIICRSDV/HOST_D0	Default: NAND data 0 (U15) via RN4. RMII carrier sense/receive data valid (U29.36), host connector data 0 (P9.31), land grid array via P6.B3.
PH1	ND_D1/ERXER/HOST_D1	Default: NAND data 1 (U15) via RN4. PHY receive error (U29.21), host connector data 1 (P9.29), land grid array via P6.B2
PH2	ND_D2/MDIO/HOST_D2	Default: NAND data 2 (U15) via RN4. PHY management bus MDIO U29 via SW12.1, host connector data 2 (P9.27), land grid array via P6.B6.
PH3	ND_D3/ETXEN/HOST_D3	Default: NAND data 3 (U15) via RN4. PHY transmit enable (U29.6), host connector data 3 (P9.25), land grid array via P6.B5.

ADSP-BF526 EZ-Board Hardware Reference

Table 2-3. PH Port Programmable Flag Connections (Cont'd)

Processor Pin	Other Processor Function	EZ-Board Function
PH4	ND_D4/MIITXCLK/ RMIIREF_CLK/HOST_D4	Default: NAND data 4 (U15) via RN4. PHY RMII ref clock U29 via SW12.3 and U20, host connector data 4 (P9.23), land grid array via P6.B9.
PH5	ND_D5/ETXD0/HOST_D5	Default: NAND data 5 (U15) via RN4. PHY RMII transmit data 0 (U29.23), host connector data 5 (P9.21), land grid array via P6.B8.
PH6	ND_D6/ERXD0/HOST_D6	Default: NAND data 6 (U15) via RN4. PHY RMII receive data 0 (U29.18), PHY mode via SW11.3, host connector data 6 (P9.19), land grid array via P6.B11.
PH7	ND_D7/ETXD1/HOST_D7	Default: NAND data 7 (U15) via RN4. PHY RMII transmit data 1 (U29.24), host connector data 7 (P9.17), land grid array via P6.B12.
PH8	SPISEL4#/ERXD1/ HOST_D8/TACLK2	Default: PHY RMII receive data 1 (U29.17) via RN5. PHY mode via SW11.2, host connector data 8 (P9.15), expansion interface II (P2.22, P4.22), land grid array via P6.B15.
PH9	SPISEL5#/ETXD2/ HOST_D9/TACLK3	Default: host connector P9.13, expansion interface II P2.23, P4.23, land grid array via P6.B27.
PH10	ND_CE#/ERXD2/HOST_D10	Default: NAND chip (U15) enable via SW13.4 Host connector data 10 (P9.11), land grid array via P6.B26.
PH11	ND_WE/ETXD3/HOST_D11	Default: NAND write enable (U15). Host connector data 11 (P9.9), land grid array via P6.B24.
PH12	ND_RE/ERXD3/HOST_D12	Default: NAND output enable (U15). Host connector data 12 (P9.7), land grid array via P6.B21.
PH13	ND_BUSY/ERXCLK/ HOST_D13	Default: NAND busy (U15). Host connector data 13 (P9.5), land grid array via P6.B23.

Programmable Flags

Table 2-3. PH Port Programmable Flag Connections (Cont'd)

Processor Pin	Other Processor Function	EZ-Board Function
PH14	ND_CLE/ERXDV/HOST_D14	Default: NAND command latch enable (U15). Host connector data 14 (P9.3), land grid array via P6.B18.
PH15	ND_ALE/COL/HOST_D15	Default: NAND address latch enable (U15). Host connector data 15 (P9.1), land grid array via P6.B17.

Table 2-4. PJ Port Programmable Flag Connections

Processor Pin	Other Processor Function	EZ-Board Function
PJ0	PPIFS1/TMRO	Default: PPIFS1 P3.13. Land grid array P7.B21.
PJ1	PPICLK/TMRCLK	Default: PPICLK P3.16. Land grid array P7.A7.
PJ2	SCL	Default: fuel gauge U38 via switch SW4.3, digipot U34 via U39 via RN5. Codec via SW2.4, expansion interface II (P2.29, P3.63, P4.29).
PJ3	SDA	Default: fuel gauge U38 via switch SW4.4, digipot U34 via U39 via RN5. Codec via SW2.2, expansion interface II (P2.30, P3.61, P4.30).

Push Button and Switch Settings

This section describes operation of the push buttons and switches. The push button and switch locations are shown in [Figure 2-2](#).

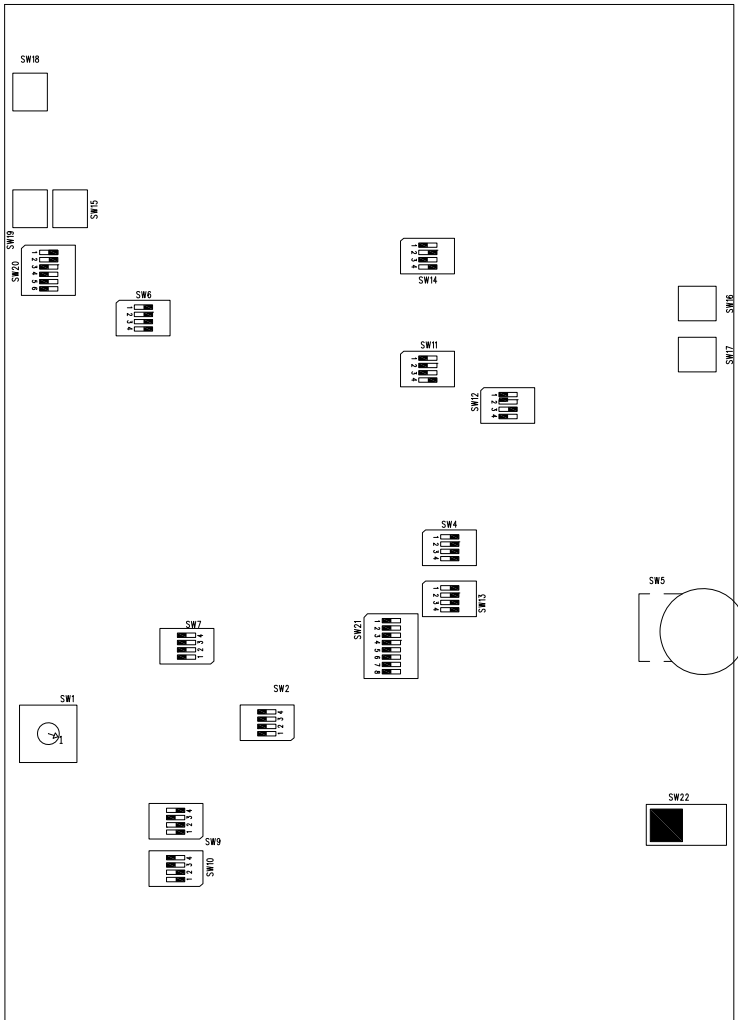

Figure 2-2. Push Button and Switch Locations

Boot Mode Select Switch (SW1)

The rotary switch (SW1) determines the boot mode of the processor. [Table 2-5](#) shows the available boot mode settings. By default, the ADSP-BF526 processor boots from the on-board parallel flash memory.

 The selected position of SW1 is marked by the notch down the entire rotating portion of the switch, not the small arrow.

Table 2-5. Boot Mode Select Switch (SW1)

SW1 Position	Processor Boot Mode
0	Reserved
1	Boot from 8-bit external flash memory (default)
2	Boot from 16-bit asynchronous FIFO
3	Boot from serial SPI memory
4	Boot from SPI host device
5	Boot from serial TWI memory
6	Boot from TWI host
7	Boot from UART0 host
8	Boot from UART1 host
9	Reserved
A	Boot from SDRAM
B	Boot from 8-bit NAND flash PORTF
C	Boot from 8-bit NAND flash PORTH
D	Reserved
E	Boot from 16-bit host DMA
F	Boot from 8-bit host DMA

SPORT0A ENBL Switches/I2C ENBL (SW2 and SW7)

The SPORT0A enable switches (SW2 and SW7) connect the SPORT0A and TWI interfaces of the processor to the audio codec, SSM2603 (U31). When the SPORT0A interface is used on the expansion interface II, turn SW2 and SW7 positions 1 and 2 all OFF. To disconnect TWI to the audio codec turn SW2 positions 3 and 4 OFF. By default, SW2 and SW7 are set to all ON.

Gauge Signals Switch (SW4)

The gauge signals switch (SW4) positions 1 and 2 disconnect the fuel gauge status LEDs from the BQ27500 fuel gauge device. Positions 3 and 4 disconnect the I²C signals from the fuel gauge. If the I²C bus hangs when performing fast bus operations, it may be necessary to turn positions 3 and 4 OFF. By default, SW4 is set to all ON.

Rotary Encoder with Momentary Switch (SW5)

The rotary encoder (SW5) can be turned clockwise for an up count or counter-clockwise for a down count. The encoder also features a momentary switch, activated by pushing the switch towards the processor, which resets the counter to zero. The rotary encoder is a two-bit quadrature (gray code) encoder. Refer to the Rotary Counter section of the *ADSP-BF52x Blackfin Processor Hardware Reference* for more information.

The rotary encoder is disconnected from the processor by setting SW13 positions 1, 2 and 3 to OFF. See [“Rotary/NAND Enable Switch \(SW13\)” on page 2-14](#) for more information.

Push Button and Switch Settings

Flash Enable Switch (SW6)

The flash enable switch (SW6) disconnects the $\overline{\text{AMSx}}$ signals from parallel flash memory (U16), allowing other devices to utilize the signals via the expansion interface II. For each switch listed in [Table 2-6](#) that is turned OFF, the size of available flash memory is reduced by 1 MB.

Table 2-6. Flash Enable Switch (SW6)

SW6 Switch Position (Default)	Processor Signal
1 (ON)	$\overline{\text{AMS0}}$
2 (ON)	$\overline{\text{AMS1}}$
3 (ON)	$\overline{\text{AMS2}}$
4 (ON)	$\overline{\text{AMS3}}$

MIC Gain Switch (SW9)

The microphone gain switch (SW9) sets the gain of the MIC signal, which is connected to the top 3.5 mm jack (J4). The gain can be set to 14 dB, 0 dB, or –6 dB by turning ON position 1, 2, or 3 of SW9 (see [Table 2-7](#)). When the corresponding position for the desired gain is ON, the remaining positions must be OFF. Refer to [“Audio Interface” on page 1-22](#) for more information about the audio codec.

Table 2-7. MIC Gain Switch (SW9)

Gain	SW9 Switch Settings
5 (14 dB)	ON, OFF, OFF, OFF
1 (0 dB)	OFF, ON, OFF, OFF
0.5 (–6 dB)	OFF, OFF, ON, OFF (default)
Unused	OFF, OFF, OFF, OFF

Audio LPBK (Loopback) Switch (SW10)

The SW10 switch places the EZ-Board in a loopback to test the board for signal/circuit continuity and functionality. SW10 positions 1 and 2 connect the MICIN signal to the headphone's left and right outputs for audio loopback. Do not turn SW10 positions 1 and 2 ON at the same time. See [“Power-On-Self Test” on page 1-37](#) for more information.

SW10 positions 3 and 4 connects the line in to line out loopback. By default, SW10 is set to OFF, OFF, ON, ON.

ETH Mode/Flash CS Switch (SW11)

The Ethernet mode flash CS switch (SW11) sets the bootstrapping option for the LAN8700 RMII PHY chip (U29). The mode settings for the PHY utilize internal chip pull-ups. Setting a position 1–3 of SW11 ON connects a pull-down resistor. [Table 2-8](#) shows the default as well as the alternate switch settings.

SW11 position 4 disconnects the SPISEL1 pin from the SPI flash chip (U6). Setting SW11 position 4 OFF is useful when using SPISEL1 on the expansion interface II. By default, SW11 is set to OFF, OFF, OFF, ON.

Table 2-8. ETH Mode Flash CS Switch (SW11 Positions 1–3)

MODE[2:0] Setting	Mode Definitions
OFF, OFF, OFF	All capable, auto negotiation (default)
OFF, OFF, ON	Power down mode
OFF, ON, OFF	Repeater mode, auto negotiation
OFF, ON, ON	100Base-TX half duplex advertised, auto negotiation
ON, OFF, OFF	100Base-TX full duplex
ON, OFF, ON	100Base-TX half duplex
ON, ON, OFF	10Base-T full duplex
ON, ON, ON	10Base-T half duplex

Push Button and Switch Settings

ETH Enable Switch (SW12)

The Ethernet enable switch (SW12) enables the Ethernet interface. The Ethernet and NAND flash share the same lines and cannot operate at the same time. By default, the SW12 settings are OFF, OFF, ON, OFF (see [Table 2-9](#)). Ethernet is enabled by setting the switch to ON, ON, OFF, ON. SW12 positions 1 and 2 connect the PHY management bus (MDIO and MDC). SW12 position 3 ON enables the 50 MHz RMI clock. SW12 position 4 holds the PHY in reset (set to OFF) or connects the PHY reset to the EZ-Board reset (set to ON).

Table 2-9. ETH Enable Switch (SW12)

SW12 Switch Setting	Ethernet Mode
OFF, OFF, ON, OFF	OFF (default)
ON, ON, OFF, ON	ON

Rotary/NAND Enable Switch (SW13)

The rotary/NAND enable switch (SW13) disconnects the rotary encoder signals from the GPIO pins of the processor. When SW13 is OFF, its associated GPIO signals can be used on the expansion interface II (see [Table 2-10](#)). Position 4 of SW13 disconnects the chip enable for the NAND flash memory (U4).

Table 2-10. Rotary NAND Enable Switch (SW13)

SW13 Position (Default)	From	To
1 (ON)	Encoder (SW5)	Processor (U1, PF13)
2 (ON)	Encoder (SW5)	Processor (U1, PF12)
3 (ON)	Encoder (SW5)	Processor (U1, PF11)
4 (ON)	Processor (U1, PH10)	NAND (U15)

UART Setup Switch (SW14)

The UART setup switch (SW14) configures the UART1 signals from the GPIO pins of the processor. By default, SW14 is OFF, ON, OFF, ON. Flow control is not implemented in the POST program, so SW14 positions 1 and 3 should be OFF and position 4 should be ON for loopback flow control. Refer to the ADM1385 data sheet on the Analog Devices Web Site for more information about the UART interface.

Programmable Flag Push Buttons (SW15 and SW19)

Two momentary push buttons (SW15 and SW19) are provided for general-purpose user input. The buttons connect to the PG0 and PG13 GPIO pins of the processor. The push buttons are active high and, when pressed, send a high (1) to the processor. The GPIO enable switch (SW20) disconnects the push buttons from the corresponding push button signals. Refer to [“GPIO Enable Switch \(SW20\)” on page 2-16](#) for more information.

Power-Down and Wake Push Buttons (SW16–17)

Two momentary push buttons (SW16–17) are provided for optional power feature inputs. The buttons connect to the PG12 and PG15 GPIO pins of the processor. The push buttons are active high and, when pressed, send a high (1) to the processor. The GPIO enable switch (SW20) disconnects the push buttons from the corresponding push buttons signals. Refer to [“GPIO Enable Switch \(SW20\)” on page 2-16](#) for more information.

The power-down push button (SW16) is intended as an GPIO input to the processor and can be configured to put the processor in any one of the sleep modes.

The wake push button (SW17) is connected to the flag pin (PG15), which can be configured as the dedicated WAKE input signal from hibernation. Refer to the *ADSP-BF52x Blackfin Processor Hardware Reference Manual* for more information.

Push Button and Switch Settings

Reset Push Button (SW18)

The reset push button (SW18) resets the following ICs.

- Processor (U1), parallel flash (U16), PHY (U29) if SW12 position 4 is ON, SPI flash (U6)

The reset push button does not reset the following ICs.

- SDRAM (U14), NAND flash (U15)
- Audio codec (U31), UART1 (U21), voltage translators (U3, U4, U32, U39) schmitt trigger hex inverter (U5)
- Fuel gauge (U38), digipot (U34), battery charger (U37), power (VR2–3, VR5, VR9, VR10, U23)

The reset push button does not reset the standalone debug agent once the debug agent is connected to a personal computer (PC). After communication between the debug agent and PC is initialized, pushing a reset button does not reset the USB chip on the debug agent. The only way to reset the USB chip on the debug agent is to power down the EZ-Board.

GPIO Enable Switch (SW20)

The general-purpose input/output switch (SW20) disconnects the associated push buttons and LED circuits from the GPIO pins of the processor and allows the signals to be used for other purposes. Depending on the switch configuration, the signals can be used as push buttons, one-time-programmable memory (OTP) flag for writing, or on-the-go (OTG) host mode 5V (see [Table 2-11](#)).

Table 2-11. GPIO Enable Switch (SW20)

SW20 Position (Default)	From	To	Function
1 (ON)	Push button 1 (SW19)	Processor (U1, PG0)	ON (PB1) OFF (UART1 CTS U21, host connector P9.12, expansion interface II P2.37, P4.37, J1.52)
2 (ON)	Push button 2 (SW15)	Processor (U1, PG13)	ON (PB2) OFF (host connector P9.8, OTP flag for writes SW20.8, OTG voltage select SW13.7, expansion interface II P2.40, P4.40, J1.53)
3 (OFF)	Power down push button (SW16)	Processor (U1, PG12)	OFF (LED2 not driven by the power down push button) ON (SW16 drives PG12)
4 (OFF)	Wake push button (SW17)	Processor (U1, PG15)	ON (connects the wake push button SW17 to PG15)
5 (OFF)	OTP_FLAG_1P8V (U3)	Processor (U1, PG13)	ON (PG13 controls the OTP flag for OTP writes) Requires SW20.2 OFF, SW20.6 OFF, and JP16 installed
6 (OFF)	USB_VRSEL (U23)	Processor (U1, PG13)	ON (PG13 controls USB_VRSEL PG13 for OTG host power) Requires SW20.2 OFF and SW20.5 OFF

The OTP memory writes require a precise 7V supply, which is turned on by setting high the `OTP_FLAG_1P8V` signal. The OTP flag is connected to the processor by setting positions 2 and 6 of SW20 to OFF and position 5 ON. These settings connect the PG13 flag pin of the processor to the shutdown pin of the precise 7V circuit VR9.

The `USB_VRSEL` provides 5V to a device connected over the USB OTG interface when running in host mode. A connection to the `USB_VRSEL` signal is set by the SW13 switch (positions 2 and 5 OFF and position 6 ON). Then the PG13 programmable flag pin of the processor can be used to control the p-channel mosfet (U23). Refer to [“USB OTG Interface” on page 1-23](#) for more information.

Push Button and Switch Settings

A power-down push button can be connected to the processor's flag pin PG12 if position 3 of SW20 is ON.



Turning SW20 position 2 ON allows the SW16 push button to control LED2.

A wake signal can be driven to the processor's dedicated hibernate wake flag PG15 by turning SW20 position 4 ON. This setting can conflict with the SPORT0A, Ethernet, and host interfaces. See [“Power-Down and Wake Push Buttons \(SW16–17\)” on page 2-15](#) for more information.

The PGO flag pin of the processor can be used as an GPIO or other functions if SW20 position 1 is turned OFF. By default, the SW20 is set to ON, ON, OFF, OFF, OFF, OFF.

SPORT1 Enable (SW21)

The SPORT1 enable switch (SW21) disconnects the following processor interfaces from the P4 connector of the EZ-Board expansion interface II: UART1RX, UART1TX, CUD, CDG, CZM, UART1RTS, PPID9, and LED0. To enable the SPORT1 interface at P4, turn SW21 all ON. By default, SW21 is all OFF.

Battery Switch (SW22)

The battery switch (SW22) connects and disconnects the ADP2291 lithium ion battery from the EZ-board power. When SW22 is ON, the board can run and charge from the battery attached to the back of the board. Jumper P25 should be removed when SW22 is OFF. SW22 is OFF by default.

Jumpers

This section describes functionality of the configuration jumpers. [Figure 2-2](#) shows the configuration jumper locations.

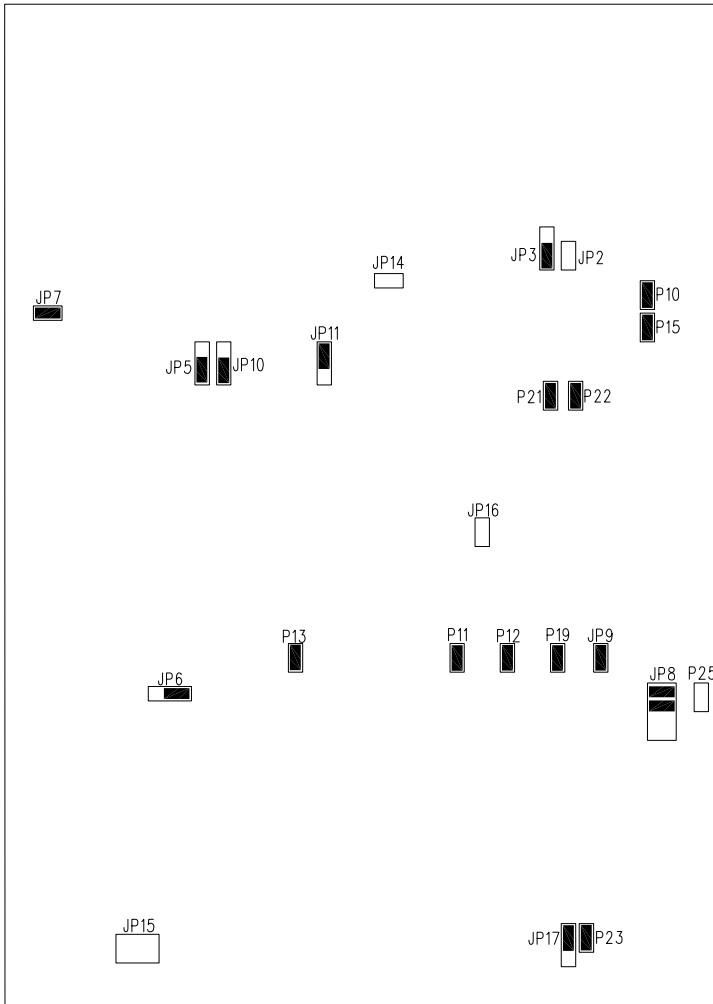

Figure 2-3. Configuration Jumper Locations

Jumpers

UART Loopback Jumper (JP2)

The UART loopback jumper (JP2) is used to place the UART1 port of the processor in a loopback condition. The jumper connects the UART1_TX line of the processor to the UART1_RX signal of the processor. The jumper is required when the POST program is run to test the serial port interface. By default, JP2 is uninstalled.

UART Enable Jumper (JP3)

The UART enable jumper (JP3) is a three-pin jumper that controls the output enable (\overline{OE}) of the UART1 voltage translator. When JP3 is uninstalled, the voltage translator outputs are tri-stated. When a jumper is placed on positions 1 and 2 of JP3, the inverted copy of the WAKEUP_OUT signal ($\overline{WAKEUP_OUT}$) controls the output enable of the voltage translator. When the EZ-board boots, the processor enables the voltage translator; when the processor is in hibernate, the translator outputs are tri-stated. A jumper on positions 2 and 3 of JP3 allows the translator to drive the outputs. See [“Power Architecture” on page 1-30](#) for more information on power saving capabilities of the ADSP-BF526 EZ-Board. By default, JP3 is installed on positions 1 and 2.

LED Enable Jumper (JP5)

The LED enable jumper (JP5) enables the power saving feature of the board through control of the voltage translator's output enable pins. When no jumper is installed on JP5, the voltage translator (U3), which controls the GPIO LEDs, and the OTP_FLAG signals are tri-stated. Placing a jumper on positions 1 and 2 of JP5 allows the inverted WAKEUP_OUT signal ($\overline{WAKEUP_OUT}$) to control the output enable of the translator. When the processor is not in hibernate, the translator is enabled; when the processor is in hibernate, the translator outputs are tri-stated. Placing a jumper on positions 2 and 3 of JP5 enables the translator outputs. See [“Power Architecture” on page 1-30](#) and [“Power Saving Features” on page 1-35](#) for more

information about the power saving capabilities of the EZ-Board. By default, JP5 is installed on positions 1 and 2.

MIC Select Jumper (JP6)

The microphone select jumper (JP6) connects the MICBIAS signal to the MICIN signal (JP6 on positions 1 and 2) or connects the MICBIAS signal to the 3.5 mm connector J4 (JP6 on positions 2 and 3). By default, JP6 is installed on positions 2 and 3.

CFG WP Jumper (JP7)

The CFG WP jumper (JP7) is used to write-protect block 70 of the parallel flash chip. Block 70 contains 64 KB of configuration data at address range 0x203 F0000–0x203 FFFFF. When a jumper is installed on JP7, and the parallel flash driver from Analog Devices is used, block 70 is read-only. By default, JP7 is installed.

EXP 5V Select Jumper (JP8)

The EXP 5V select jumper (JP8) selects the 5V voltage source for the expansion interface II connectors J1, P2, P3, and P4. JP8 must have either no jumpers or two jumpers installed, never one or three jumpers. When jumpers are placed on positions 1, 2 and 3, 4 of JP8, the 5V power rail for the expansion interface II is sourced from the wall adaptor. When jumpers are placed on positions 5, 6 and 7, 8 of JP8, 5V is sourced by the boost regulator VR7. By default, JP8 is installed on positions 1, 2 and 3, 4.

VR7 Enable Jumper (JP9)

The VR7 enable jumper (JP9) controls the shut-down pin of the ADP1611 boost regulator, which is a 5V source for the expansion interface II. When installed, JP9 disables VR7. Install JP9 when using positions 1,2 and 3,4 of JP8 because the 5V source for the expansion interface II is the wall

Jumpers

adaptor. Removing JP9 allows VR7 to drive 5V to the expansion interface II; the battery is providing the input to VR7. This setting drains the battery at a much faster rate. See [“EXP 5V Select Jumper \(JP8\)” on page 2-21](#) for more information. By default, JP9 is installed (VR7 is disabled).

SENSE2 Select Jumper (JP10)

The SENSE2 select jumper (JP10) selects between the 3.3V regulator (VR2) and battery voltage as a monitored input for the reset signal. When a jumper is on positions 1 and 2 of JP10, the BAT_P signal is monitored, which is useful when using the 740 mAh lithium ion battery. When a jumper is on positions 2 and 3 of JP10, the 3.3V regulator (VR2) is monitored. This setting must be used when no battery is wired to connector P24. The SENSE2 input pin of the ADM13305 voltage reset supervisor is set to drive the `RESET_3V` signal low when a voltage of less than 3.16V is measured. By default, JP10 is installed on positions 2 and 3.

RST/ETH LED Jumper (JP11)

The RST/ETH LED jumper (JP11) enables the power saving feature of the board through control of the voltage translator's output enable pins. When JP11 is not installed, the voltage translator (U4), which controls Ethernet LEDs, and `RESET_3V` signals are tri-stated. Placing a jumper on positions 1 and 2 of JP11 allows the inverted `WAKEUP_OUT` signal (`WAKEUP_OUT`) to control the output enable of the translator. When the processor is not in hibernate, the translator is enabled; when the processor is in hibernate, the translator outputs are tri-stated. Placing a jumper on positions 2 and 3 of JP11 enables the translator outputs. See [“Power Architecture” on page 1-30](#) and [“Power Saving Features” on page 1-35](#) for more information about the power saving capabilities of the EZ-Board. By default, JP11 is installed on positions 1 and 2.

UART SD Jumper (JP14)

The UART SD jumper (JP14) enables the power saving feature of the ADM1385 UART line driver by controlling the driver's shut-down pin. When installed, JP14 disables the transmitters and receivers of the UART line driver. See [“Power Architecture” on page 1-30](#) and [“Power Saving Features” on page 1-35](#) for more information on the power saving capabilities of the EZ-Board. By default, JP14 is uninstalled.

CHG GPIO Jumper (JP15)

The CHG GPIO jumper (JP15) selects the flag pin of the processor to control the ADP2291 single cell lithium ion charge rate (see [Table 2-12](#)). Note that only settings that are listed in the table are supported. For an explanation of each setting, see [“Power Architecture” on page 1-30](#). JP15 is used in conjunction with the P23 and JP17 jumper settings. See the following sections for more information: [“R274 JMP Jumper \(P23\)” on page 2-26](#), [“CHG Control Jumper \(JP17\)” on page 2-24](#), and [“Power Measurements” on page 1-36](#). By default, JP15 is uninstalled.

Table 2-12. CHG GPIO Settings

JP15 Setting	Signal	FLAG pin
Uninstalled	PUSHBUTTON1_HWAIT	Not applicable (default)
1 and 2	PUSHBUTTON1_HWAIT	PG0
3 and 4	LED1_HOSTWR#	PG11
5 and 6	LED2_HOSTACK	PG12

OTP Flag Enable Jumper (JP16)

The OTP flag enable jumper (JP16) controls the precise 7V OTP voltage regulator (VR9). When installed, JP16 allows OTP writes. JP16 must be used in conjunction with the SW20 GPIO enable switch. Refer to [“GPIO Enable Switch \(SW20\)” on page 2-16](#) for more information.

Jumpers

JP16 must be installed for OTP writes to be successful. The nominal 2.5V for OTP is temporarily raised to 7V when SW20 is configured properly and PG13 is set high. Care must be taken when SW20 is configured for the OTP_FLAG signal in order to avoid VR9 driving 7V for an extended amount of time.

 There is a limited amount of time that 7V can be applied to the processor's OTP interface. Violating the specifications listed in the *ADSP-BF522/523/524/525/526/527 Blackfin Embedded Processor Data Sheet* can damage the processor.

Configured properly, SW20 and JP16 connect the processor's PG13 flag pin to the shut-down pin of the ADP1611 switching converter (VR9). Refer to [“GPIO Enable Switch \(SW20\)” on page 2-16](#), the *ADSP-BF52x Blackfin Processor Hardware Reference Manual*, and the *ADSP-BF522/523/524/525/526/527 Blackfin Embedded Processor Data Sheet* for more information about OTP writes.

CHG Control Jumper (JP17)

The CHG control jumper (JP17) selects the control line for the mosfet attached to the charge rate adjustment pin of the ADP2291 linear charger. When no jumper is installed, the on-board pull-up holds the gate of the mosfet ON. Placing a jumper on positions 1 and 2 of JP17 allows the processor's flag pin, selectable by JP15, to control the gate of the mosfet. Placing a jumper on positions 2 and 3 of JP17 pulls the mosfet gate to ground, disconnecting the drain and the source. For more information on the ADP2291 single cell lithium ion battery charger, see [“Power Architecture” on page 1-30](#).

The JP17 jumper is used in conjunction with the P23 and JP15 jumpers; see the following sections for more information: [“R274 JMP Jumper \(P23\)” on page 2-26](#), [“CHG GPIO Jumper \(JP15\)” on page 2-23](#), and [“Power Measurements” on page 1-36](#). By default, JP17 is installed on positions 2 and 3.

VDDEXT Power Jumper (P11)

The VDDEXT power jumper (P11) is used to measure the processor's I/O voltage and current. By default, JP11 is ON: the power flows through the two-pin IDC header. To measure power, remove the jumper and measure voltage across the 0.1 ohm resistor. Once voltage is measured, power can be calculated. For more information, refer to [“Power Measurements” on page 1-36](#).

VDDMEM Power Jumper (P12)

The VDDMEM power jumper (P12) is used to measure the voltage and current supplied to the memory interface of the processor. By default, P12 is ON: the power flows through the two-pin IDC header. To measure power, remove P12 and measure voltage across the 0.1 ohm resistor. Once voltage is measured, power can be calculated. For more information, refer to [“Power Measurements” on page 1-36](#).

VDDINT Power Jumper (P13)

The VDDINT power jumper (P13) is used to measure the core voltage and current supplied to the processor core. P13 is ON by default, and the power flows through the two-pin IDC header. To measure power, remove P13 and measure voltage across the 0.1 ohm resistor. Once voltage is measured, power can be calculated. For more information, refer to [“Power Measurements” on page 1-36](#).

ETH PWR Jumpers (P21–22)

The ETH PWR jumpers (P21–22) disconnect the SMSC LAN8700 Ethernet PHY from the 1.8V and 3.3V power supplies. When P21–22 are removed, all power is disconnected from the PHY, which is a great benefit for low-power consumption applications that do not require Ethernet. See [“Power Architecture” on page 1-30](#) and [“Power Saving Features” on](#)

Jumpers

[page 1-35](#) for more information about the power saving capabilities of the EZ-Board. By default, P21–22 are installed.

R274 JMP Jumper (P23)

The R274 JMP jumper (P23) provides a means to short out a R274 set resistor in the charge rate circuit of the ADP2291 single cell lithium ion battery. P23 bypasses R274 when installed and effectively makes a zero ohm connection to the WALL_SENSE signal. For more information on the ADP2291 battery charger, see [“Power Architecture” on page 1-30](#). P23 is used in conjunction with the JP17 and JP15 jumpers; see the following sections for more information: [“CHG Control Jumper \(JP17\)” on page 2-24](#), [“CHG GPIO Jumper \(JP15\)” on page 2-23](#), and [“Power Measurements” on page 1-36](#). By default, P23 is uninstalled.

BATT Installed Jumper (P25)

The BATT installed jumper (P25) serves as an indication to the BQ27500 fuel gauge that a lithium ion battery is installed. When using the battery, install a jumper on P25 before turning ON the battery’s power switch (SW22). By default, P25 is uninstalled.

LEDs

This section describes the on-board LEDs. [Figure 2-4](#) shows the LED locations.

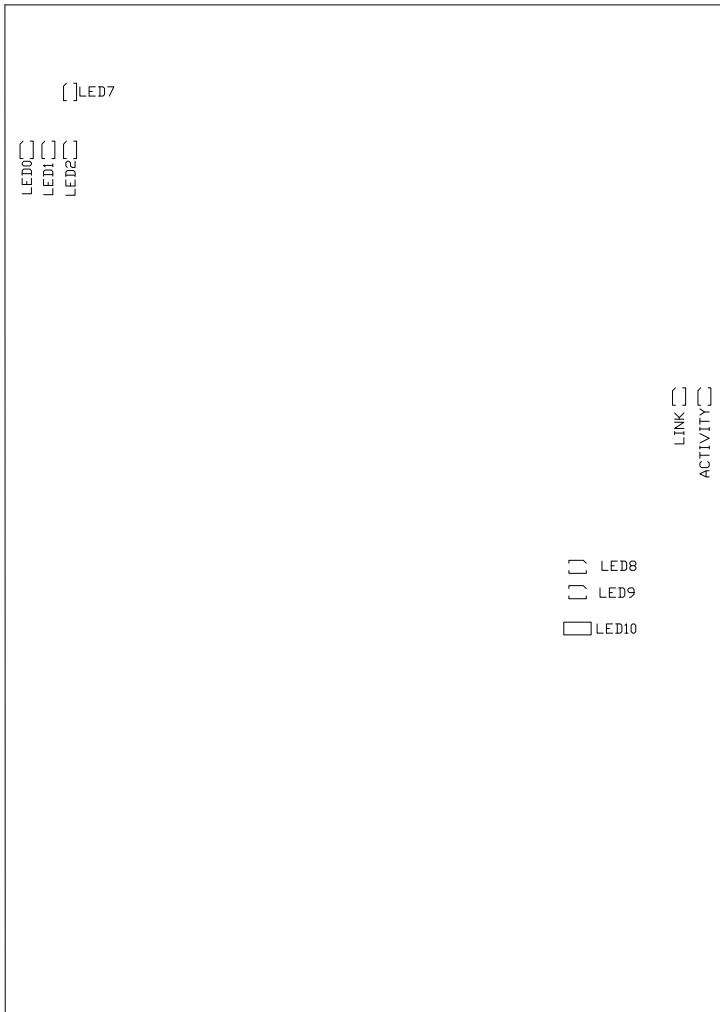

Figure 2-4. LED Locations

LEDs

Ethernet LEDs (LED1–2)

When LED2 is lit solid, it indicates that the SMSC LAN8700 chip (U29) detects a valid link. When transmit or receive activity is sensed, LED1 flashes as an activity indicator. For more information on the LEDs, refer to the LAN8700 chip data sheet provided by the product manufacturer.

GPIO LEDs (LED3–5)

Three LEDs connect to three general-purpose I/O pins of the processor (see [Table 2-13](#)). The LEDs are active high and are lit by writing a 1 to the correct programmable flag signal.

Table 2-13. GPIO LEDs

LED Reference Designator	Processor Programmable Flag Pin
LED0	PF8
LED1	PG11
LED2	PG12

Reset LED (LED7)

When LED7 is lit, it indicates that the master reset of all major ICs is active. The reset LED is controlled by the Analog Devices ADM13305 supervisory reset circuit. You can assert the reset push button (SW18) to assert a master reset and activate LED7. [For more information, see “Reset Push Button \(SW18\)” on page 2-16.](#)

Batt GD LED (LED8)

When LED8 is lit (green), it indicates that the BQ27500 fuel gauge (U38) has successfully initialized the lithium ion battery. This is not an indication of the battery capacity. When the battery switch (SW22) is OFF, but the

battery installed jumper (P25) is ON, the battery GD LED still illuminates. Ensure that P25 is installed only when SW22 is ON.

Batt Low LED (LED9)

When LED9 is lit (yellow), it indicates that the BQ27500 fuel gauge (U38) has detected that the lithium ion battery is low. The low threshold can be programmed; for more information, refer to the BQ27500 data sheet provided by the product manufacturer.

Charging LED (LED10)

When LED10 illuminates, it indicates that the lithium ion battery is receiving a charge from either the 5V wall adaptor (P14) or the USB OTG connector (P8).

Connectors

This section describes connector functionality and provides information about mating connectors. [Figure 2-5](#) shows the connector locations.

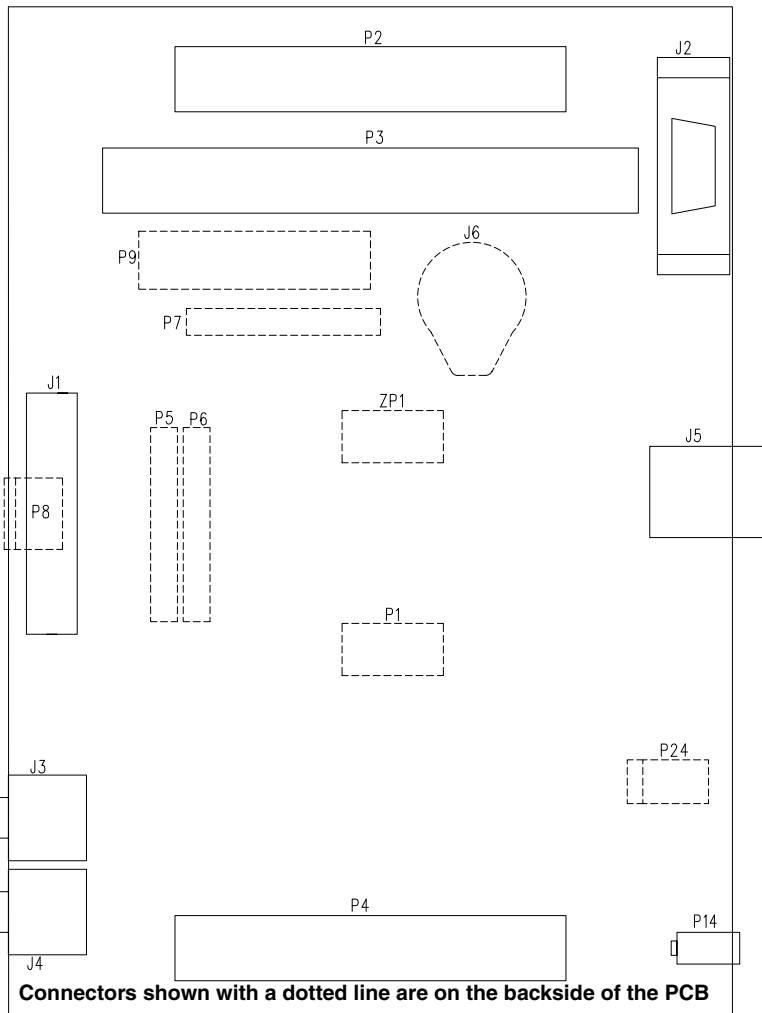

Figure 2-5. Connector Locations

Expansion Interface II Connector (J1)

J1 is a board-to-board connector providing signals from the external bus interface unit (EBIU) of the processor. The connector is located on the left edge of the board. For more information, see [“Expansion Interface II” on page 1-29](#). For availability and pricing of the connector, contact Samtec.

Part Description	Manufacturer	Part Number
104-position 0.025", SMT header	SAMTEC	QMS-052-11-L-D-A
Mating Connector		
104-position 0.025", SMT socket	SAMTEC	QFS-052-01-L-D-A

RS-232 Connector (J2)

Part Description	Manufacturer	Part Number
DB9, female, vertical mount	NORCOMP	191-009-213-L-571
Mating Cable		
2m female-to-female cable	DIGI-KEY	AE1020-ND

Dual Audio Connectors (J3-4)

Part Description	Manufacturer	Part Number
3.5 mm dual stereo jack	SWITCHCRAFT	35RAPC7JS
Mating Cable (shipped with EZ-Board)		
3.5 mm male/male 6' cable	RANDOM	10A3-01106

Connectors

Ethernet Connector (J5)

Part Description	Manufacturer	Part Number
RJ-45 Ethernet jack	STEWART	SS-6488-NF
Mating Cable (shipped with EZ-Board)		
Cat 5E patch cable	RANDOM	PC10/100T-007

Battery Holder (J6)

Part Description	Manufacturer	Part Number
16 mm battery holder	MEMORY PROTECTION	BH600
Mating Battery (shipped with EZ-Board)		
3V 125MAH 16 mm LI-COIN	PANASONIC	CR1632

JTAG Connector (P1)

The JTAG header is the connecting point for the JTAG interface to the ADSP-BF526 processor. The standalone debug agent requires both connectors P1 and ZP1.

Pin 3 is missing to provide keying. Pin 3 in the mating connector should have a plug.

When using an emulator with the EZ-Board, the standalone debug agent must be removed. Follow the installation instructions provided in [“CCES Install and Session Startup” on page 1-5](#) or [“VisualDSP++ Install and Session Startup” on page 1-9](#), using P1 as the JTAG connection point.

Expansion Interface II Connectors (P2 and P4)

P2 and P4 are board-to-board connectors providing signals for the SPI, TWI, UART, SPORT interfaces and GPIO signals of the processor. The connectors are located on the upper and lower edges of the board. For more information, see [“Expansion Interface II” on page 1-29](#). For availability and pricing of the connectors, contact Samtec.

Part Description	Manufacturer	Part Number
50-position 0.1”, SMT header	SAMTEC	TSSH-125-01-L-DV-A
Mating Connector		
50-position 0.1”, SMT socket	SAMTEC	SSW-125-22-F-D-VS

Expansion Interface II Connector (P3)

P3 is a board-to-board connector providing signals for the PPI, TWI, and GPIO signals of the processor. The connector is located on the upper edge of the board. For more information, see [“Expansion Interface II” on page 1-29](#). For availability and pricing of the connector, contact Samtec.

Part Description	Manufacturer	Part Number
70-position 0.1”, SMT header	SAMTEC	TSSH-135-01-L-DV-A
Mating Connector		
70-position 0.1”, SMT socket	SAMTEC	SSW-135-22-F-D-VS

DMAX Land Grid Array Connectors (P5–7)

The land grid array areas (P5–7) are intended for the probing of the processor signals. The pads are exposed and designed to attach a Tektronix logic analyzer to the connectors listed in [Table 2-14](#). P5 and P6 require the primary retention connectors, while P7 can connect to either the primary

Connectors

or alternate retention connectors. For more information about the land grid array, consult the Tektronix Web site.

Table 2-14. DMAX Land Grid Array Connectors (P5–7)

Part Description	Manufacturer	Part Number
Primary retention	TEKTRONIX	020290800
Alternate retention	TEKTRONIX	020291000

USB OTG Connector (P8)

The pinout of the P8 connector can be found in [“ADSP-BF526 EZ-Board Schematic” on page B-1](#).

Part Description	Manufacturer	Part Number
USB 5-pin mini AB	MOLEX	56579-0576
Mating Cable (shipped with EZ-Board)		
3M mini USB 2.0 cable	ASSMANN	AK672M/2-3

Host Interface Connector (P9)

The pinout of the P9 connector can be found in [“ADSP-BF526 EZ-Board Schematic” on page B-1](#).

Part Description	Manufacturer	Part Number
IDC header	SAMTEC	TSW-116-26-T-D
Mating Connector		
IDC socket	SAMTEC	TSW-116-01-T-D

Power Connector (P14)

The power connector (J6) provides all of the power necessary to operate the EZ-Board.

Part Description	Manufacturer	Part Number
0.65 mm power jack	CUI	045-0883R
Mating Power Supply (shipped with EZ-Board)		
5.0VDC@2.5A power supply	CUI STACK	DMS050260-P12P-SZ

Battery Connector (P24)

P24 is a connection point of a single 3.3V lithium ion battery. Ensure that the positive lead of the battery is inserted to the side labeled “+”, and the negative terminal is inserted to the side labeled “-”. To remove the battery leads, press the white plastic button in and slide out the lead. The battery is not connected until the SW22 switch is ON.

Part Description	Manufacturer	Part Number
Wire to board, push-in, 16–28 AWG	WEIDMULLER	281-2020-ND
Mating Battery (shipped with EZ-Board)		
3.7V lithium ion battery, 950 mAh	MOUSER	5169-UBP563450

Standalone Debug Agent Connector (ZP1)

ZP1 connects the standalone debug agent to the EZ-Board. The standalone debug agent requires both the ZP1 and P1 connectors. For more information, see [“CCES Install and Session Startup” on page 1-5](#) or [“VisualDSP++ Install and Session Startup” on page 1-9](#).

Connectors

A ADSP-BF526 EZ-BOARD BILL OF MATERIALS

The bill of materials corresponds to “[ADSP-BF526 EZ-Board Schematic](#)” on page B-1.

Ref.	Qty.	Description	Reference Designator	Manufacturer	Part Number
1	1	74LVC14A SOIC14	U5	TI	74LVC14AD
2	1	MMBT3904 SOT23	Q5	MOUSER	512-MMBT3904
3	1	32.768KHZ OSC008	U12	EPSON	MC-156-32.7680KA-A0:ROHS
4	4	SN74LVC1G08 SOT23-5	U24-27	TI	SN74LVC1G08DBVR
5	1	HX1188 ICS007	U28	DIGI-KEY	553-1340-ND
6	1	LAN8700 QFN3	U29	SMSC	LAN8700C-AEZG
7	1	NJT4030P SOT-223	VR8	ON SEMI	NJT4030PT1G
8	1	50MHZ OSC012	U20	ECS INC	ECS-3518-500-B-TR
9	1	SN74AUC1G00 SOT23-5	U9	TI	SN74AUC1G00DBVR
10	1	BF526 M58WR032KB “U16”	U16	NUMONYX	M58WR032KB70ZB6E F
11	1	BF526 BQ27500 “U33” OBS	U38	DIGI-KEY	296-22633-2-ND
12	1	BF526 SST25WF 040 “U6”	U6	SST	SST25WF040-40-5I- SAF

Ref.	Qty.	Description	Reference Designator	Manufacturer	Part Number
13	1	25MHz OSC013	Y1	DIGI-KEY	535-9140-1-ND
14	1	24MHz OSC013	Y2	DIGI-KEY	535-9138-2-ND
15	1	12MHz OSC014	Y3	DIGI-KEY	535-9100-1-ND
16	1	SI1012R SC-75A	Q1	VISHAY	SI1012R-T1-E3
17	4	SI2333DS SOT23D	Q2-4,Q6	VISHAY	SI2333DS-T1-E3
18	1	GTL2002DC VSSOP8	U39	DIGI-KEY	568-1869-1-ND
19	4	FXL2T245 MAC010A	U4,U32,U40-41	FAIRCHILD SEMI	FXL2T245L10X
20	1	FXL4T245 MLP014A	U3	FAIRCHILD SEMI	FXL4T245BQX
21	1	MIC2025-2 SOIC8	U2	MICREL	MIC2025-2YM
22	1	NAND02 TFBGA63_80_95 X120	U15	NUMONYX	NAND02GR3B2CZ A6E
23	1	MT48H32M16 VFBGA54_80x90	U14	DIGI-KEY	557-1390-1-ND
24	1	ADSP-BF526 BGA208	U1	ANALOG DEVICES	ADSP-BF526BBCZ- 4AX
25	1	ADP1715 MSOP8	VR5	ANALOG DEVICES	ADP1715ARMZ-R7
26	1	ADP1710 TSOT5	VR10	ANALOG DEVICES	ADP1710AUJZ-R7
27	1	ADR550B SOT23-3	U35	ANALOG DEVICES	ADR550BRTZ-REEL7
28	1	ADP2291 MSOP8	U37	ANALOG DEVICES	ADP2291ARMZ-R7
29	1	ADP2105-1.8V LFCSP16	VR3	ANALOG DEVICES	ADP2105ACPZ-1.8-R7

ADSP-BF526 EZ-Board Bill Of Materials

Ref.	Qty.	Description	Reference Designator	Manufacturer	Part Number
30	1	ADP2105-3.3V LFCSP16	VR2	ANALOG DEVICES	ADP2105ACPZ-3.3- R7
31	1	ADM13305-4 SOIC8	U22	ANALOG DEVICES	ADM13305-4ARZ
32	1	AD5258 MSOP10	U34	ANALOG DEVICES	AD5258BRMZ10
33	1	ADM1385ARSZ SSOP20	U21	ANALOG DEVICES	ADM1385ARSZ
34	1	AD8619ARUZ TSSOP14	U36	ANALOG DEVICES	AD8619ARUZ
35	2	ADP1610 MSOP8	VR7,VR9	ANALOG DEVICES	ADP1610ARMZ-R7
36	1	SSM2603 ICS009	U31	ANALOG DEVICES	SSM2603CPZ-R2
37	1	ADP120-AUJZ18 R7 TSOT5	VR1	ANALOG DEVICES	ADP120-AUJZ18R7
38	1	DIP8 SWT016	SW21	C&K	TDA08H0SB1
39	1	DIP6 SWT017	SW20	CTS	218-6LPST
40	10	DIP4 SWT018	SW2,SW4,SW6-7, SW9-14	ITT	TDA04HOSB1
41	1	DB9 9PIN CON038	J2	NORCOMP	191-009-213-L-571
42	10	IDC 2X1 IDC2X1	P10-13,P15,P19,P21- 23,P25	FCI	90726-402HLF
43	5	IDC 2X1 IDC2X1	JP2,JP7,JP9,JP14,JP16	FCI	90726-402HLF
44	6	IDC 3X1 IDC3X1	JP3,JP5-6,JP10-11,JP17	FCI	90726-403HLF
45	20	IDC 2PIN_JUMPER_ SHORT	SJ1-9,SJ11-14,SJ16, SJ21-22,SJ26-29	DIGI-KEY	S9001-ND

Ref.	Qty.	Description	Reference Designator	Manufacturer	Part Number
46	1	IDC 3X2 IDC3X2	JP15	BURG	54102-T08-03LF
47	1	PWR .65MM CON045	P14	DIG	CP1-023-ND
48	1	IDC 4X2 IDC4X2	JP8	SULLINS	GEC04DAAN
49	1	5A RESETABLE FUS005	F1	MOUSER	650-RGEF500
50	1	ROTARY SWT023	SW1	DIGI-KEY	563-1047-ND
51	2	3.5MM DUAL_STEREO CON050	J3-4	SWITCH- CRAFT	35RAPC7JS
52	1	USB_MINI-AB 5PIN CON052	P8	MOLEX	56579-0576
53	1	RJ45 8PIN CON_RJ45_12P	J5	DIGI-KEY	380-1022-ND
54	5	MOMENTARY SWT024	SW15-19	PANASONIC	EVQ-Q2K03W
55	1	ROTARY_ENC_ EDGE SWT025	SW5	PANASONIC	EVQ-WKA001
56	1	QMS 52x2 QMS52x2_SMT	J1	SAMTEC	QMS-052-06.75-L- D-A
57	1	IDC 16x2 IDC16x2_SMT	P9	SAMTEC	TSM-116-01-T-DV
58	2	IDC 25x2 IDC25x2_SMTA	P2,P4	SAMTEC	TSSH-125-01-L-DV-A
59	1	IDC 35x2 IDC35x2_SMTA	P3	SAMTEC	TSSH-135-01-L-DV-A
60	1	IDC 7x2 IDC7x2_SMTA	P1	SAMTEC	TSM-107-01-T-DV-A

ADSP-BF526 EZ-Board Bill Of Materials

Ref.	Qty.	Description	Reference Designator	Manufacturer	Part Number
61	1	BATT_HOLDER 16MM BATT_COI	J6	MEMORY PROTECTI	BH600
62	1	POWER 2X1 CON064	P24	WEID- MULLER	1824420000
63	1	SPDTSWT026	SW22	NKK SWITCHES	CS12ANW03
64	3	10 1/8W 5% 1206	R154-155,R310	KOA	RK73B2BTTD100J
65	5	YELLOW LED001	LED2-5,LED9	DIGI-KEY	P512TR-ND
66	1	600 100MHZ 200MA 0603	FER13	DIGI-KEY	490-1014-2-ND
67	3	600 100MHZ 500MA 1206	FER1,FER17-18	STEWART	HZ1206B601R-10
68	1	1UF 16V 10% 0805	C97	KEMET	C0805C105K4RAC TU
69	1	10 1/10W 5% 0805	R92	VISHAY	CRCW080510R0 FKEA
70	2	10UF 16V 20% CAP002	CT1-2	PANASONIC	EEE1CA100SR
71	1	0 1/10W 5% 0805	R65	VISHAY	CRCW08050000 Z0EA
72	1	190 100MHZ 5A FER002	FER19	MURATA	DLW5BSN191SQ2
73	1	YELLOW LED009	LED10	PANASONIC	LNJ416Q8YRA
74	10	10UF 6.3V 10% 0805	C8,C12,C18,C23,C34, C104,C108,C120, C122,C200	AVX	08056D106KAT2A

Ref.	Qty.	Description	Reference Designator	Manufacturer	Part Number
75	25	0.1UF 10V 10% 0402	C5-7,C17,C19-22,C48, C79-80,C87,C93, C105,C109,C119, C121,C144,C147-150, C205,C216,C237	AVX	0402ZD104KAT2A
76	62	0.01UF 16V 10% 0402	C9,C35-42,C51-52, C54-59,C73,C77-78, C81-86,C88-92,C96, C98,C133,C135,C138- 141,C146,C151-152, C156-158,C160,C199, C201-204,C212,C214- 215,C236,C262-268	AVX	0402YC103KAT2A
77	16	10K 1/16W 5% 0402	R36,R72,R99-102, R121,R124,R173, R185,R190,R204, R208,R245-246,R249	VISHAY	CRCW040210K0 FKED
78	10	4.7K 1/16W 5% 0402	R26,R35,R66-68,R73, R83-85,R95	VISHAY	CRCW04024K70 JNED
79	16	0 1/16W 5% 0402	R12,R14,R18,R98, R111,R168,R192-199, R244,R308	PANASONIC	ERJ-2GE0R00X
80	7	33 1/16W 5% 0402	R6,R10-11,R13,R82, R203,R309	VISHAY	CRCW040233R0 JNEA
81	1	150UF 10V 10% D	CT5	AVX	TPSD157K010R0050
82	5	1A SK12 DO-214AA	D13,D19-22	DIODES INC	B120B-13-F
83	8	0.1UF 16V 10%0603	C76,C184,C194,C245, C251,C254-255,C257	AVX	0603YC104KAT2A
84	1	10UF 10V +80/-20% 0805	C256	PANASONIC	ECJ-2FF1A106Z
85	7	1UF 16V 10% 0603	C11,C13,C112-114, C259,C269	KEMET	C0603C105K4PACTU

ADSP-BF526 EZ-Board Bill Of Materials

Ref.	Qty.	Description	Reference Designator	Manufacturer	Part Number
86	4	4.7UF 25V 20% 0805	C178-179,C188-189	AVX	0805ZD475KAT2A
87	1	68PF 50V 5% 0603	C195	AVX	06035A680JAT2A
88	5	4.7UF 6.3V 20% 0603	C143,C181,C234-235, C238	PANASONIC	ECJ-1VB0J475M
89	3	470PF 50V 5% 0603	C252,C258,C261	AVX	06033A471JAT2A
90	1	.022UF 16V 10% 0603	C145	AVX	06033C223KAT2A
91	2	220UF 6.3V 20% D2E	CT3-4	SANYO	10TPE220ML
92	1	10M 1/10W 5% 0603	R2	VISHAY	CRCW060310M0 FNEA
93	10	100K 1/10W 5% 0603	R175,R265,R268, R277,R279,R282, R286,R289-290,R293	VISHAY	CRCW0603100KJNEA
94	4	1M 1/10W 5% 0603	R40,R278,R283,R291	VISHAY	CRCW06031M00 FNEA
95	5	0 1/10W 5% 0603	R54-55,R136,R248, R261	PHYCOMP	232270296001L
96	10	49.9 1/16W 1% 0603	R74-76,R79-81,R88-91	VISHAY	CRCW060349R9 FNEA
97	4	10 1/10W 5% 0603	R115,R127,R130,R135	VISHAY	CRCW060310R0 JNEA
98	1	75.0K 1/16W 1% 0603	R164	VISHAY	CRCW060375K0FKEA
99	1	1K 1/10W 5% 0603	R276	DIGI-KEY	311-1.0KGRTR-ND
100	4	0.1 1/10W 1% 0603	R156-158,R188	PANASONIC	ERJ-3RSFR10V

Ref.	Qty.	Description	Reference Designator	Manufacturer	Part Number
101	1	10.0K 1/10W 1% 0603	R259	DIGI-KEY	311-10.0KHRTR-ND
102	1	120PF 50V 5% 0603	C185	AVX	06035A121JAT2A
103	9	100PF 50V 5% 0603	C100-103,C115-118, C209	PANASONIC	ECJ-1VC1H101J
104	2	1000PF 50V 5% 0603	C183,C193	PANASONIC	ECJ-1VC1H102J
105	1	12.4K 1/10W 1% 0603	R93	DIGI-KEY	311-12.4KHRTR-ND
106	1	2200PF 50V 5% 0603	C250	PANASONIC	ECJ-1VB1H222K
107	2	75.0 1/10W 1% 0603	R77-78	DALE	CRCW060375R0FKEA
108	6	100 1/16W 5% 0402	R51,R56,R116,R119, R129,R133	DIGI-KEY	311-100JRTR-ND
109	1	2.05K 1/16W 1% 0402	R306	VISHAY	CRCW04022K05FKED
110	1	4.99K 1/16W 1% 0603	R71	VISHAY	CRCW06034K99FKEA
111	3	10UF 10V 10% 0805	C94,C99,C142	PANASONIC	ECJ-2FB1A106K
112	1	2.0K 1/16W 1% 0603	R252	PANASONIC	ERJ-3EKF2001V
113	9	10UF 16V 10% 1210	C10,C191,C206-207, C243-244,C247,C249, C273	AVX	1210YD106KAT2A
114	2	GREEN LED001	LED1,LED8	PANASONIC	LN1361CTR
115	1	RED LED001	LED7	PANASONIC	LN1261CTR
116	2	1000PF 50V 5% 1206	C180,C182	AVX	12065A102JAT2A

ADSP-BF526 EZ-Board Bill Of Materials

Ref.	Qty.	Description	Reference Designator	Manufacturer	Part Number
117	2	18K 1/16W 5% 0402	R177,R270	DIGI-KEY	311-18KJRCT-ND
118	6	430 1/16W 1% 0402	R109-110,R114,R120, R262-263	DIGI-KEY	311-430LRCT-ND
119	2	22000PF 25V 10% 0402	C208,C241	DIGI-KEY	490-3252-1-ND
120	2	5A MBRS540T3G SMC	D7,D18	ON SEMI	MBRS540T3G
121	3	15KV PGB1010603 0603	D8-10	LITTLEFUSE	PGB1010603MR
122	1	VARISTOR V5.5MLA 30A 0603	R1	LITTLEFUSE	V5.5MLA0603
123	1	THERM 0.5A 0.4 1206	R167	LITTLEFUSE	1206L050-C
124	1	20MA MA3X717E DIO005	D1	PANASONIC	MA3X717E
125	2	330.0 1/16W 1% 0402	R94,R97	DIGI-KEY	541-330LCT-ND
126	1	33.0K 1/16W 1% 0402	R9	ROHM	MCR01MZPF3302
127	8	47.0K 1/16W 1% 0402	R39,R47-48,R50,R52- 53,R57,R61	ROHM	MCR01MZPF4702
128	2	3.01K 1/16W 1% 0402	R301-302	ROHM	MCR01MZPF3011
129	1	5.6K 1/16W 5% 0402	R307	PANASONIC	ERJ-2GEJ562X
130	4	1.0K 1/16W 1% 0402	R105-107,R237	PANASONIC	ERJ-2RKF1001X

Ref.	Qty.	Description	Reference Designator	Manufacturer	Part Number
131	2	1000PF 2000V 10% 1206	C131-132	AVX	1206GC102KAT1A
132	4	1UF 50V 10% 0603	C153-155,C159	DIGI-KEY	587-1257-2-ND
133	1	154.0K 1/16W 1% 0402	R165	DIGI-KEY	541-154KLCT-ND
134	10	10.0K 1/16W 1% 0402	R27-29,R58,R69-70, R86-87,R169,R172	DIGI-KEY	541-10.0KLCT-ND
135	4	5.6K 1/16W 0.5% 0402	R41,R44-46	SUSUMU	RR0510P-562-D
136	2	680 1/16W 1% 0402	R43,R273	BC COMPO- NENTS	2312 275 16801
137	1	90.9K 1/16W 5% 0402	R42	DIGI-KEY	541-90.9KLCT-ND
138	1	40.2K 1/16W 5% 0402	R49	DIGI-KEY	541-40.2KLCT-ND
139	34	100K 1/16W 5% 0402	R4-5,R8,R17,R20-25, R30-34,R59,R62-64, R96,R103-104,R117- 118,R122-123,R125- 126,R128,R131,R134, R171,R207,R305	DIGI-KEY	541-100KJTR-ND
140	1	3.3UF 16V 10% 0805	C125	DIGI-KEY	490-3337-2-ND
141	3	2.2UF 25V 10% 0805	C240,C246,C253	DIGI-KEY	490-3331-1-ND
142	3	22UF 16V 10% 1210	C177,C187,C190	YAIYO YUDEN	EMK325BJ226KM-T
143	6	1.00K 1/10W 0.1% 0603	R264,R266,R280-281, R288,R296	DIGI-KEY	RG16P1.0KBCT-ND
144	1	21.5K 1/10W 1% 0603	R260	DIGI-KEY	311-21.5KHRCT-ND

ADSP-BF526 EZ-Board Bill Of Materials

Ref.	Qty.	Description	Reference Designator	Manufacturer	Part Number
145	5	1A MBR130LSFT1G SOD-123FL	D12,D14-17	ON SEMI	MBR130LSFT1G
146	1	22UH 20% IND018	L7	COILCRAFT	MSS4020-223MLB
147	1	1UH 20% IND019	L6	COILCRAFT	ME3220-102MLB
148	1	0.2 1/4W 1% 0805	R285	SUSUMU	RL1220S-R20-F
149	1	40K 1/16W 0.1% 0402	R274	STACKPOLE	RNC 10 T9 40K 0.1% R
150	1	30.9K 1/16W 1% 0402	R174	DIGI-KEY	541-30.9KLCT-ND
151	1	1.8M 1/16W 1% 0402	R271	DIGI-KEY	541-1.80MLCT-ND
152	1	10K 1/100W 1% THERMAT-2	R300	SEMITEC	103AT-2
153	2	2.7UH 10.5% IND022	L3-4	COILCRAFT	1812PS-272JLB
154	1	76.8K 1/16W 1% 0402	R178	DIGI-KEY	541-76.8KLCT-ND
155	8	18PF 50V 5% 0402	C2-3,C219-224	AVX	04025A180JAT2A
156	12	33 1/16W 5% RNS003	RN2-13	PANASONIC	EXB-2HV330JV
157	1	33 1/32W 5% RNS005	RN14	PANASONIC	EXB-28V330JX
158	1	1.2K 1/16W 1% 0402	R234	VISHAY	CRCW04021K20FKED
159	2	4.3 1/4W 5% 1206	R233,R236	PANASONIC	ERJ-8GEYJ4R3V

Ref.	Qty.	Description	Reference Designator	Manufacturer	Part Number
160	1	2.67K 1/16W 1% 0402	R235	PANASONIC	ERJ-2RKF2671X
161	3	1.0M 1/16W 1% 0402	R312-314	VISHAY	CRCW04021M00 FKED
162	1	169.0K 1/16W 1% 0402	R275	VISHAY	CRCW0402169 KFKED
163	1	0.02 1/2W 1% 1206	R272	OHMITE	LVK12R020FER
164	1	200.0K 1/16W 1% 0402	R304	ROHM	MCR01MZPF2003
165	2	15K 1/16W 5% 0402	R160,R269	PANASONIC	ERJ-2GEJ153X
166	1	3.3uH 20% IND023	L5	COILCRAFT	LPS4018-332MLC
167	3	330 100MHZ 1.5A 0805	FER10-11,FER20	MURATA	BLM21PG331SN1D
168	1	24.0K 1/10W 1% 0603	R256	PANASONIC	ERJ-3EKF2402V
169	1	140.0K 1/10W 1% 0603	R257	PANASONIC	ERJ-3EKF1403V
170	1	1.91K 1/10W .1% 0603	R253	SUSUMU	RG1608P-1911-B-T5
171	1	3.01K 1/10W .1% 0603	R254	SUSUMU	RG1608P-3011-B-T1
172	3	30A GSOT05 SOT23-3	D6,D24-25	VISHAY	GSOT05-GS08
173	1	30A GSOT03 SOT23-3	D11	VISHAY	GSOT03-GS08
174	4	40A ESD5Z2.5 T1 SOD-523	D3-5,D23	ON SEMI	ESD5Z2.5T1G

3

4

A

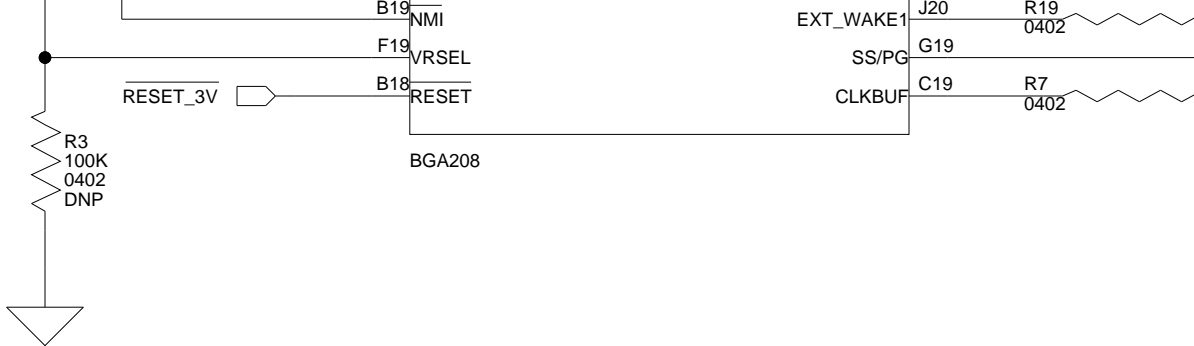

3

"DSP CLK"

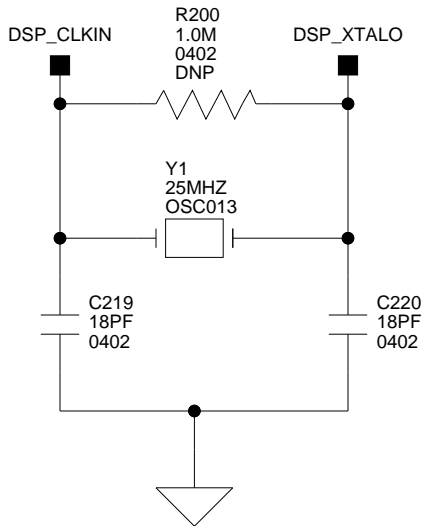

"RT"

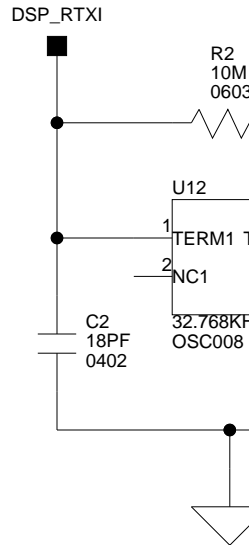

4

A

3

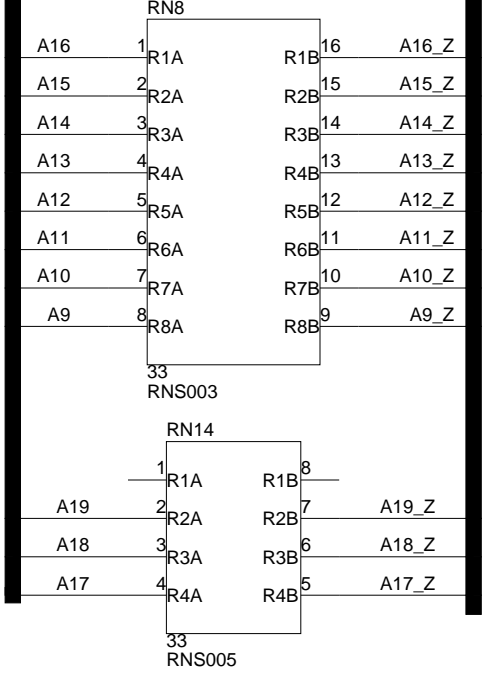

TFS0A_ PUSH

4

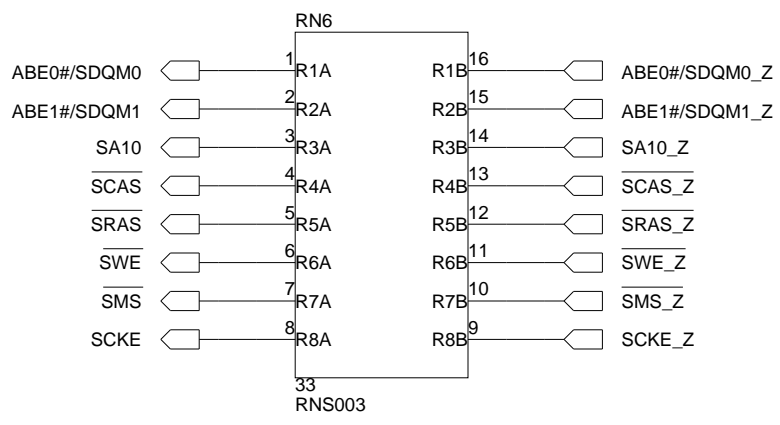
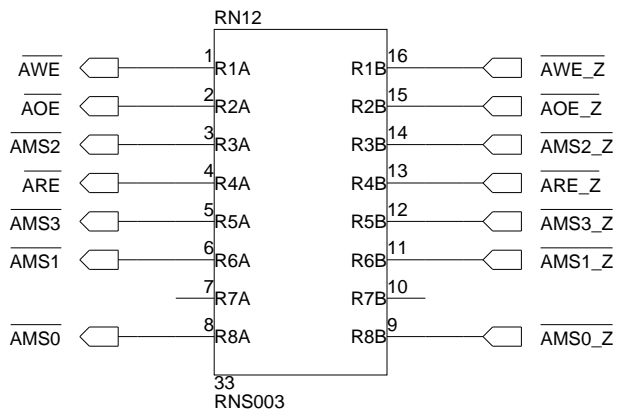

A

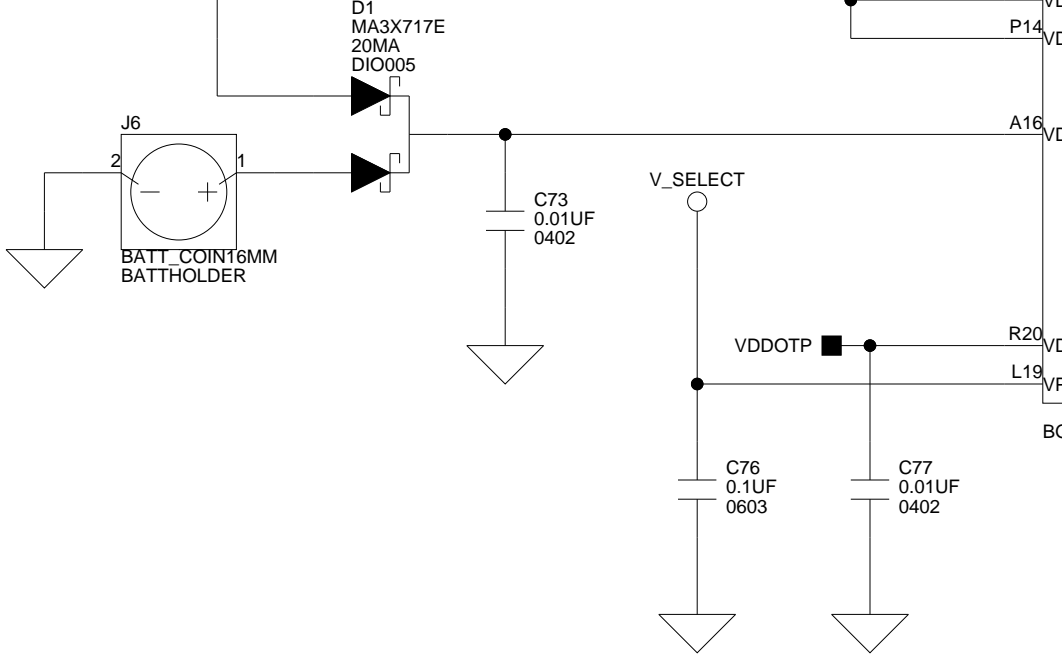

3

4

A

RESET_1P8V

ARE

AWE

SN74LVC1G08
SOT23-5

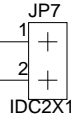

SHORTING
JUMPER
DEFAULT=INSTALLED

"CFG WP"

3

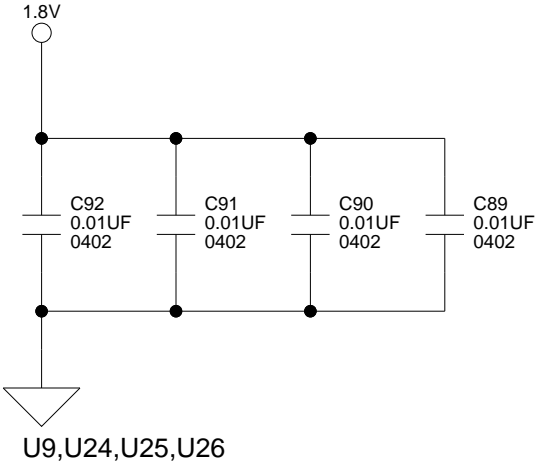

2Gb M

4

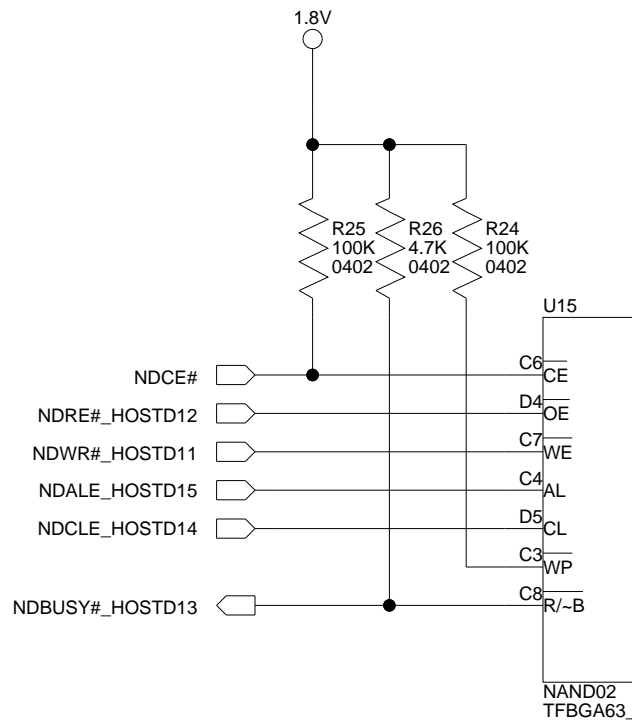
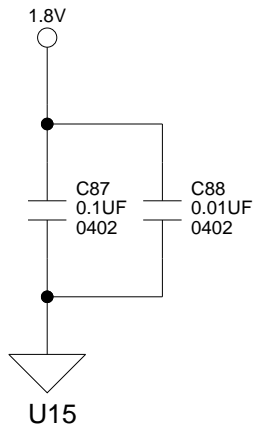

A

3

4

A

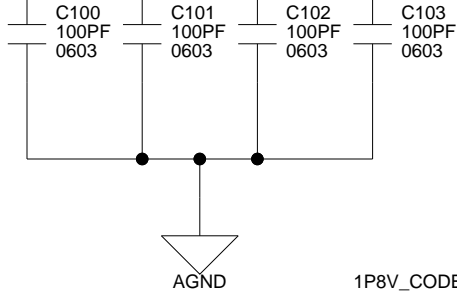

DEFAULT CODEC I2C ADDRESS 0011011

CAN BE CHANGED TO 0011010 IF R63 REMOVED AND PLACED ON R60

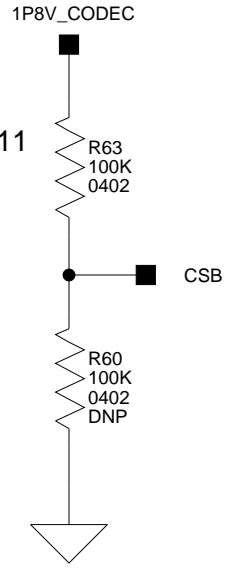

3

"SPORT"
"0A"
"ENBL"

"SPORT 0A E"
"I2C ENBL"

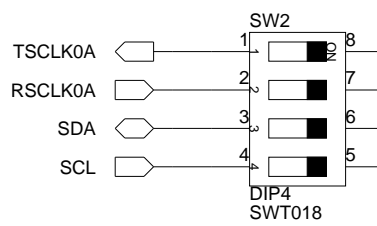
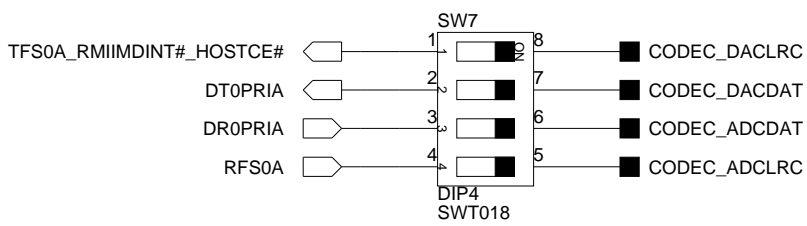

4

SW7 AND SW2 (POSITIONS 1 AND 2) DISCONNECT DSP SPORT
SW2 POSITIONS 3 AND 4 ALLOW I2C TO BE DISCONNECTED

3

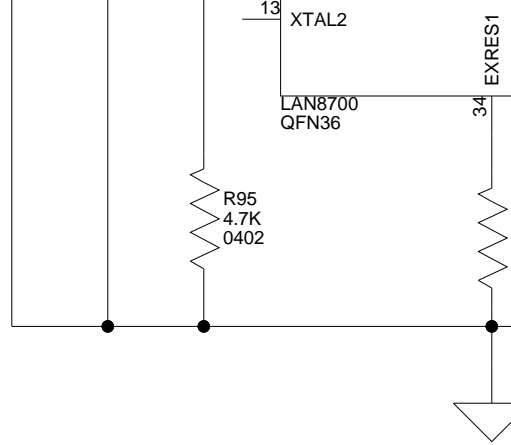

SW11: Ethernet Mode Select (SW9.1, SW9.2, SW9.3)

LAN8700 has internal mode pull-up pins. Setting of OFF = 1.

MODE[2:0]	MODE DEFINITIONS
111	All Capable, Auto Negotiation DEFAULT
110	Power Down Mode
101	Repeater Mode, Auto Negotiation
100	100Base-TX Half duplex Advertised, Auto Negotiaon
011	100Base-TX Full Duplex
010	100Base-TX Half Duplex
001	10Base-T Full Duplex
000	10Base-T Half Duplex

SW11.4 disconnects SPISEL1, for expansion interface (P1.26, P2.21)

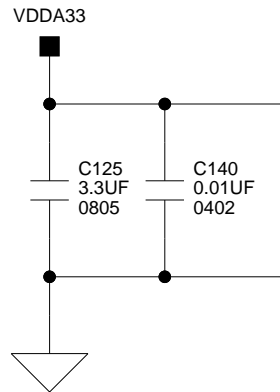

4

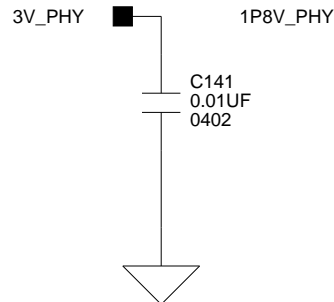
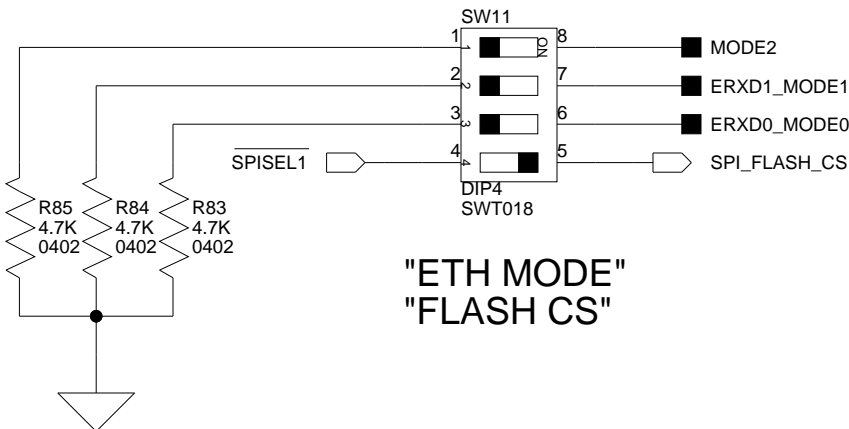

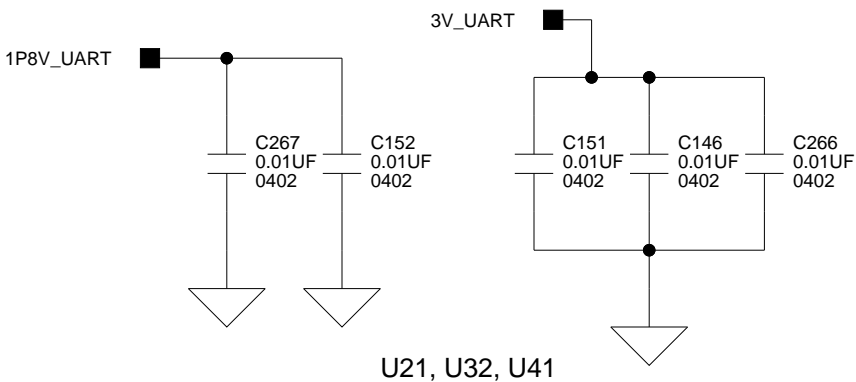
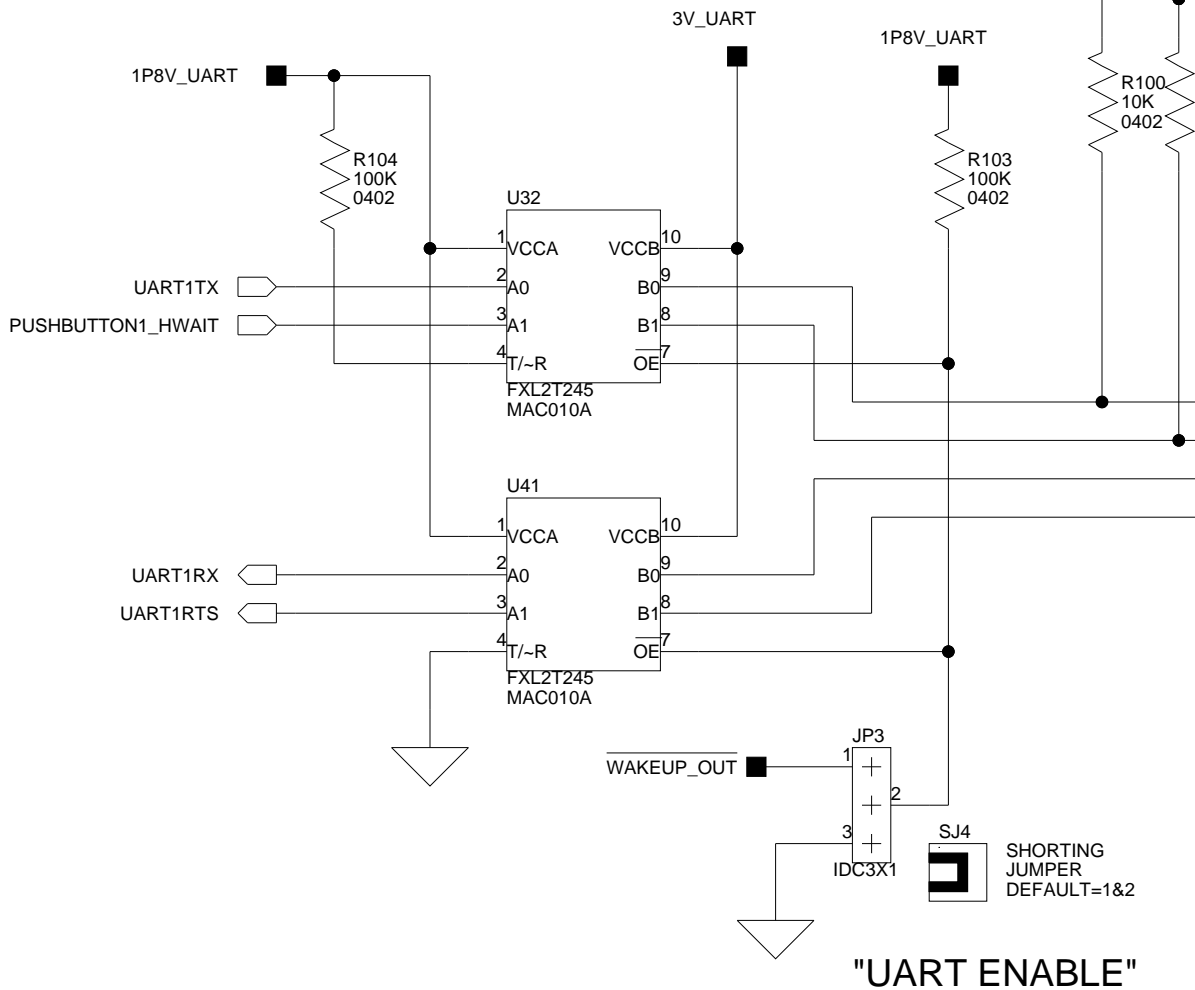

3

4

A

2 (ON)
3 (OFF)
4 (OFF)
5 (OFF)
6 (OFF)

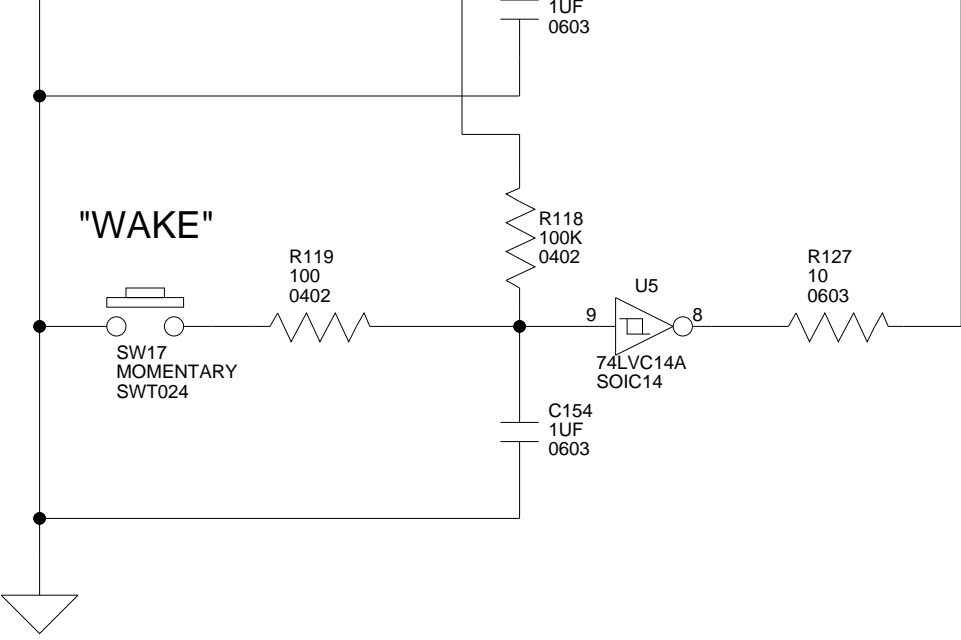

3

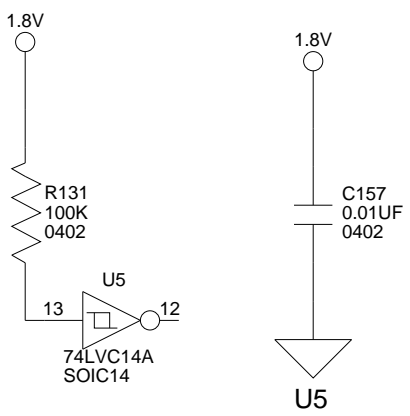
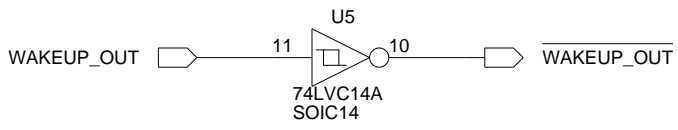

4

A

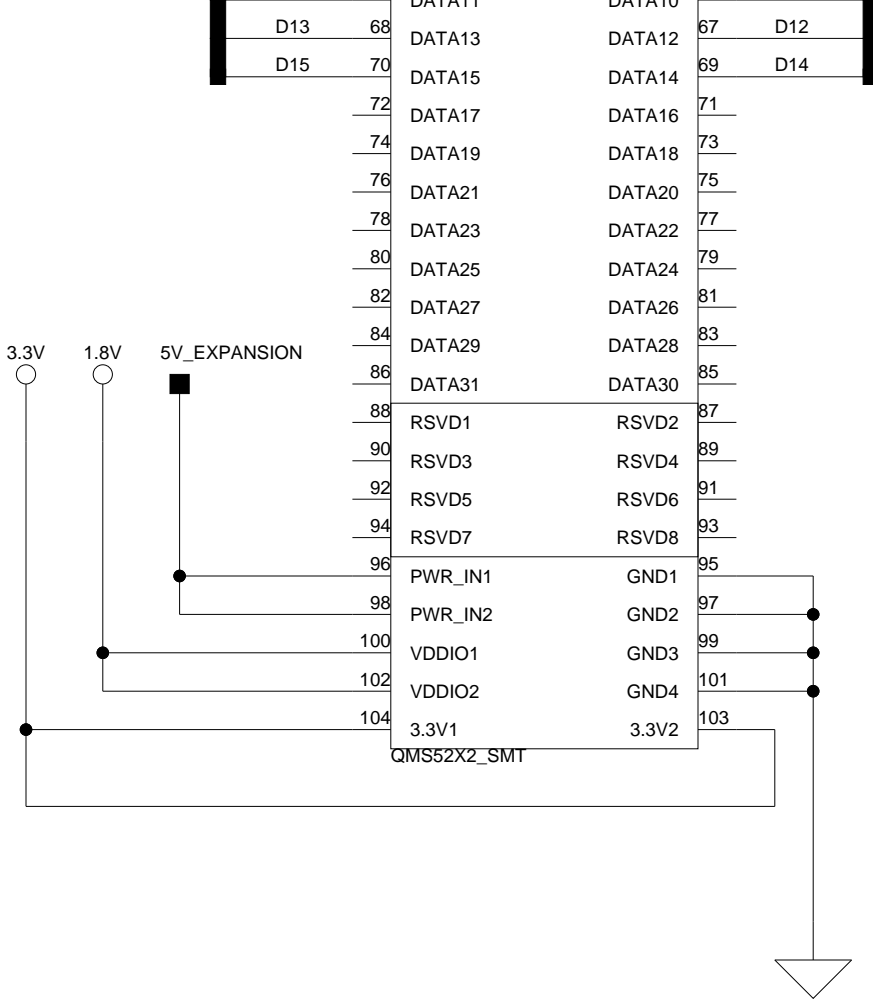

3

4

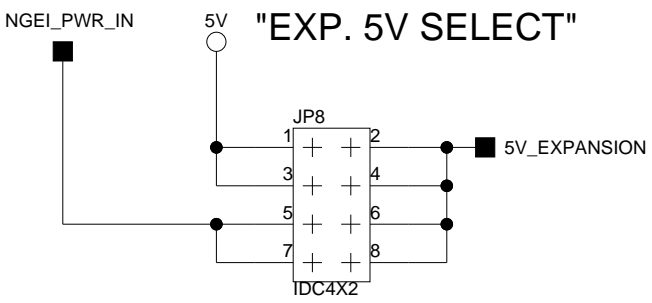

**JP8 SELECTS 5V SOURCE FOR EXPANSION CONNECTORS
EITHER WALL POWER(1&2, 3&4) OR VR7(5&6, 7&8)**

A

3

4

"VR7 ENABLE"

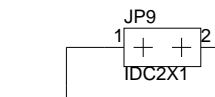

SJ9
SHORTING
JUMPER
DEFAULT=INSTALLED

REMOVE JP9 IF USING VR7 FOR
EXPANSION CONNECTOR 5V POWER

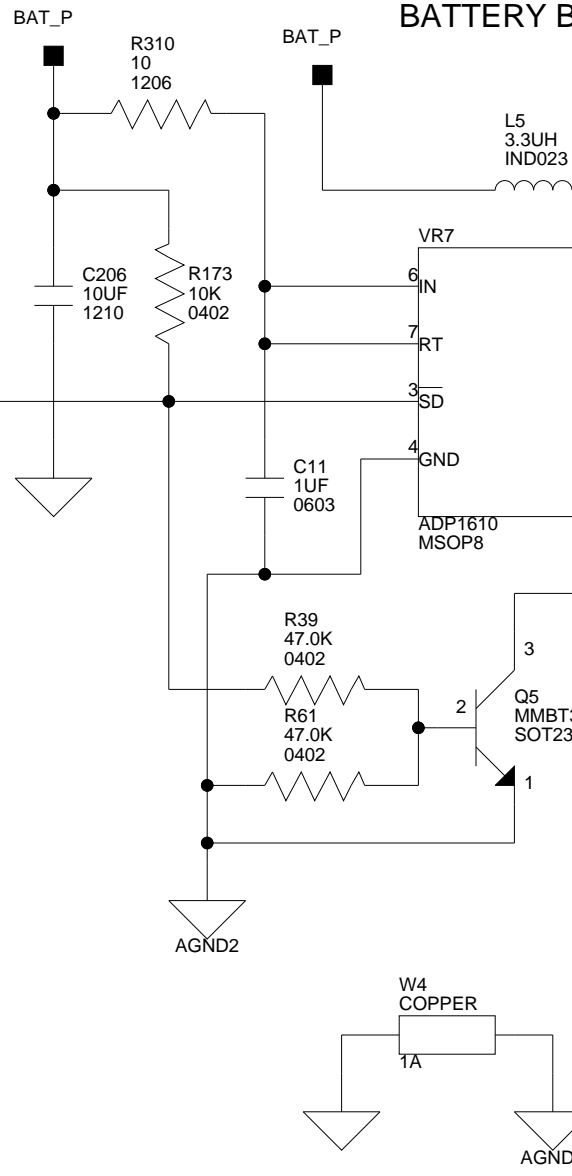

A

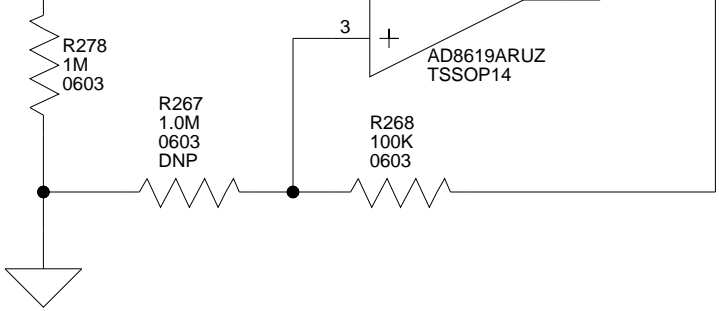

"BATT IN

3

FUEL_GAUGE_VCC

BAT_INSTALLED

FUEL GAUGE

"GAUGE SIGN

BAT_P

BAT_INSTALLED

FUEL_GAUGE_VCC

U38

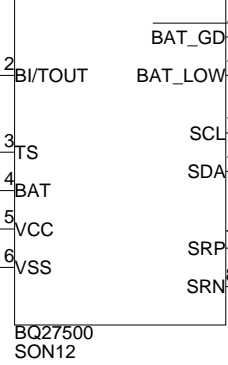

FUEL GAUGE ADDRESS 0xAA

4

A

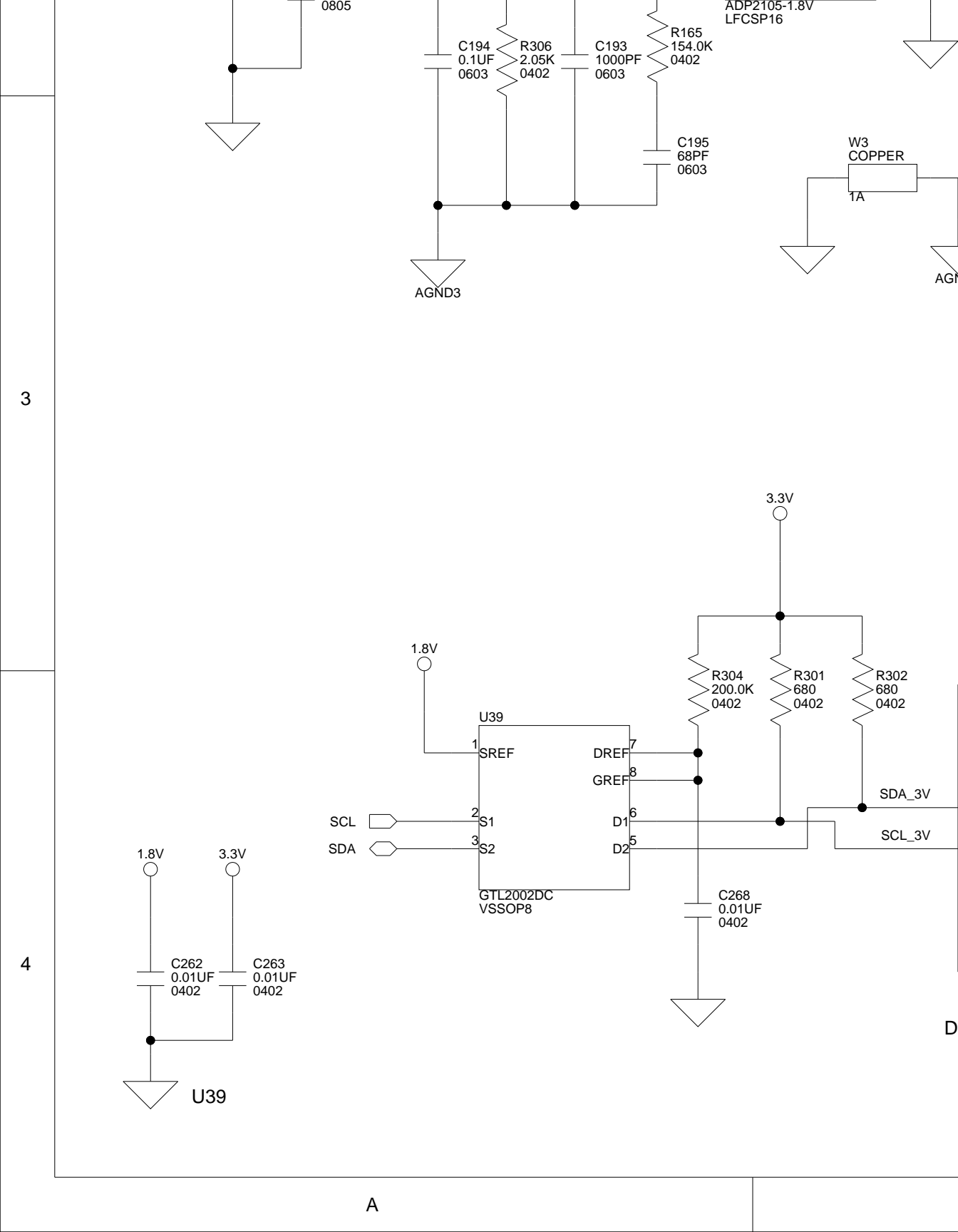

I INDEX

A

- ADM1385 line driver/receiver (U21), [1-24](#)
- ADP1715 linear regulator (VR5), [1-30](#)
- ADP2105 converter (VR2), [1-31](#)
- AMS0-3 select lines, [1-17](#)
- analog audio interface, *See* audio
- architecture, of this EZ-Board, [2-2](#)
- ASYNCR (asynchronous memory control)
 - external memory banks 0-3, [1-16](#)
- audio
 - interface, [1-22](#)
 - codec SPORT connect (SW2, SW7), [1-22](#), [2-11](#)
 - codec (U31), [1-19](#), [1-28](#)
 - dual connectors (J3-4), [1-23](#), [2-31](#)

B

- battery
 - ADP2291 battery charger, [1-32](#), [2-18](#), [2-24](#), [2-26](#)
 - charge LED (LED10), [2-29](#)
 - charge rate selection, [1-33](#)
 - connector (P24), [2-35](#)
 - GD LED (LED8), [2-28](#)
 - holder connector (J6), [2-32](#), [2-35](#)
 - installed jumper (P25), [2-18](#), [2-26](#), [2-29](#)
 - low LED (LED9), [2-29](#)
 - switch (SW22), [2-18](#)
- bill of materials, [A-1](#)
- board design database, [1-37](#)
- board schematic (ADSP-BF526), [B-1](#)

boot

- modes, [2-10](#)
- mode select switch (SW1), [1-18](#), [1-20](#)

burst flash memory, [xiii](#)

C

- CFG WP jumper (JP7), [2-21](#)
- CHG control jumper (JP17), [2-24](#)
- CHG GPIO jumper (JP15), [2-23](#)
- audio codec, *See* audio
- code security, [1-13](#)
- configuration, of this EZ-Board, [1-3](#)
- connectors
 - diagram of locations, [2-30](#)
 - J1 (expansion interface II), [1-29](#), [2-31](#)
 - J2 (RS-232), [2-31](#)
 - J3-4 (dual audio), [1-23](#), [2-31](#)
 - J5 (Ethernet), [1-22](#), [2-32](#)
 - J6 (battery holder), [2-32](#), [2-35](#)
 - P14 (power), [1-9](#), [1-10](#), [2-29](#), [2-35](#)
 - P1 (JTAG), [1-9](#), [1-28](#), [2-32](#)
 - P24 (battery), [2-35](#)
 - P2 (expansion interface II), [1-25](#), [1-29](#), [2-33](#)
 - P3 (PPI, expansion interface II), [1-20](#), [1-29](#), [2-33](#)
 - P4 (expansion interface II), [1-29](#), [2-33](#)
 - P5-7 (land grid array), [1-29](#), [2-33](#)
 - P8 (USB OTG), [1-10](#), [1-24](#), [2-29](#), [2-34](#)
 - P9 (host interface), [1-18](#), [2-34](#)
 - ZP1 (debug agent), [2-35](#)
- contents, of this EZ-Board package, [1-3](#)

Index

core voltage, [2-2](#)
CTS signal, [1-25](#)
CUD (up) signal, [1-20](#)

D

Das U-Boot, universal boot loader, [1-19](#)
debug agent connector (ZP1), [2-35](#)
default configuration, of this EZ-Board, [1-3](#)
DIP switch, *See* SW20
down signal (CDG), [1-20](#)

E

Ethernet

interface, [xiv](#), [1-21](#)
connector (J5), [1-22](#), [2-32](#)
enable switch (SW12), [1-18](#), [1-21](#), [2-14](#)
LEDs (LED1-2), [1-35](#), [2-28](#)
mode switch (SW11), [1-21](#), [2-13](#)
PHY IC (U29), [1-18](#)
PWR jumpers (P21-22), [1-35](#), [2-25](#)

evaluation license

CCES, [1-12](#)
example programs, [1-37](#)
EXP 5V select jumper (JP8), [2-21](#)
expansion interface II
connections, [1-18](#), [1-19](#)
J1 connector, [1-29](#), [2-31](#)
P2 connector, [1-25](#), [1-29](#), [2-33](#)
P3 connector, [1-20](#), [1-29](#), [2-33](#)
P4 connector, [1-29](#), [2-33](#)
UART0 (P2), [1-25](#)
UART1 (P4), [1-25](#)
external memory, [1-14](#), [1-16](#)
EXT_WAKE signal, [1-35](#)

F

features, of this EZ-Board, [xiii](#)
FET switch (U23), [1-24](#)
flag pins, *See* programmable flags by name (PFx, PGs, PHx, PJx)
flash memory enable switch (SW6), [2-12](#)
fuel gauge (U38), [1-32](#), [2-28](#)

G

general-purpose IO pins (GPIO), [1-26](#), [2-14](#),
[2-15](#), [2-16](#), [2-28](#)
GPIO enable switch, *See* SW20

H

HOSTACK signal, [1-27](#)
HOSTADDR signal, [1-24](#), [1-27](#)
HOSTD10 signal, [1-18](#)
host interface connector (P9), [1-18](#), [2-34](#)
HOSTWR signals, [1-27](#)
HWAIT port, [1-25](#)

I

I2C voltage translator, [1-30](#)
installation, of this EZ-Board, [1-9](#)
CCES, [1-5](#)
IO voltage, [2-2](#)

J

JTAG

interface, [1-28](#)
connector (P1), [1-9](#), [1-28](#), [2-32](#)

jumpers

- diagram of locations, 2-19
- JP10 (SENSE2 select), 2-22
- JP11 (RST/ETH LED), 1-35, 2-22
- JP14 (UART SD), 1-35, 2-23
- JP15 (CHG GPIO), 2-23
- JP16 (OTP flag enable), 2-23
- JP17 (CHG control), 2-24
- JP2 (UART1 loopback), 2-20
- JP3 (UART1 enable), 1-20, 1-25, 1-35, 2-20
- JP5 (LED enable), 1-35, 2-20
- JP6 (mic select), 1-23, 2-21
- JP7 (CFG WP), 2-21
- JP8 (EXP 5V select), 2-21
- JP9 (VR7 enable), 2-21
- P11 (VDDEXT power), 1-36, 2-25
- P12 (VDDMEM power), 1-36, 2-25
- P13 (VDDINT power), 1-36, 2-25
- P19 (SRAM power), 1-36
- P21-22 (ETH PWR), 1-35, 2-25
- P23 (R274 JMP), 2-26
- P25 (BATT installed), 2-18, 2-26, 2-29

L

- land grid array connectors (P5-7), 1-29, 2-33
- LED2_HOSTACK signal, 1-28
- LED enable jumper (JP5), 1-35, 2-20
- LEDs

- diagram of locations, 2-27
- LED10 (battery charge), 2-29
- LED1-2 (Ethernet), 1-35, 2-28
- LED3-5 (PF8, PG11-12), 1-26, 2-28
- LED4 (USB monitor), 1-10
- LED7 (reset), 2-28
- LED8 (batt GD), 2-28
- LED9 (battery low), 2-29

license restrictions, 1-13

Lockbox secure technology, 1-13

M

- MAC address, 1-21
- media independent interface (MII), 1-21
- Media Instruction Set Computing (MISC), xi
- memory map, of this EZ-Board, 1-14
- microphone
 - gain switch (SW9), 1-22, 2-12
 - headphone select (SW10), 1-23, 2-13
 - select jumper (JP6), 1-23, 2-21
- Micro Signal Architecture (MSA), xi

N

NAND

- flash memory interface, 1-18
- enable switch (SW3), 1-18
- NDCE#_HOSTD10 signal, 1-18
- notation conventions, xxi

O

- oscilloscope, 1-36
- OTP_FLAG signal, 1-27
- OTP memory
 - flag enable jumper (JP16), 2-23
 - writes, 1-31, 2-24

P

- package contents, 1-3
- parallel flash memory, 1-17
 - See also* NAND, flash memory
- parallel peripheral interface (PPI), *See* PPI interface
- PF0-7 programmable flags, 2-3
- PF8 programmable flag, 2-3, 2-28
- PF9-15 programmable flags, 2-3
- PG0-10 programmable flags, 2-5
- PG11 programmable flag, 2-5, 2-28
- PG12 programmable flag, 2-5, 2-28
- PG13-15 programmable flags, 2-5

Index

PH0-15 programmable flags, [2-6](#)
PJ0-3 programmable flags, [2-8](#)
POST (power-on-self test) program, [1-17](#), [1-25](#),
[1-37](#), [2-20](#)

power

5V wall adaptor (P14), [1-3](#), [1-9](#), [1-30](#), [2-29](#)
setup, [1-33](#)
connector (P14), [1-9](#), [2-29](#), [2-35](#)
down push buttons (SW16-17), [2-15](#)
measurements, [1-36](#)

power architecture, of this EZ-Board, [1-30](#)

power saving features, of this EZ-Board, [1-35](#)

PPI interface

connections, [1-20](#)
expansion interface II connector (P3), [1-20](#),
[2-4](#), [2-5](#), [2-8](#), [2-21](#), [2-33](#)

product overview, [xiii](#)

R

R274 JMP jumper (P23), [2-26](#)

real-time clock (RTC) interface, [1-26](#)

Reduced Instruction Set Computing (RISC), [xi](#)

reduced media independent interface (RMII),
[1-21](#)

reset

LED (LED7), [2-28](#)
push button (SW18), [2-16](#)

restrictions, of evaluation license, [1-13](#)

rotary encoder

interface, [1-20](#)
enable switch (SW13), [1-20](#), [2-14](#)
switch (SW5), [2-11](#)

RS-232 connector (J2), [2-31](#)

RST/ETH LED jumper (JP11), [1-35](#), [2-22](#)

RTS signal, [1-25](#)

S

schematic, of ADSP-BF526 EZ-Board, [B-1](#)

SCL signal, [1-30](#)

SDA signal, [1-30](#)

SDRAM interface, [1-16](#), [1-30](#)

SENSE2 select jumper (JP10), [2-22](#)

serial peripheral interconnect (SPI) ports, *See*
SPI interface

SPI interface

flash CS switch (SW3), [1-18](#)

SPISEL1 signal, [1-19](#)

SPORT0A enable switches (SW2, SW7), [1-22](#),
[2-11](#)

SPORT1 enable switch (SW21), [2-18](#)

SRAM memory

connections, [1-14](#)
power jumper (P19), [1-36](#)

standalone debug agent, [xii](#), [1-9](#), [1-10](#), [1-13](#),
[1-16](#), [1-28](#)

startup, of this EZ-Board

CCES, [1-5](#)

SW10 (mic select) switch, [1-23](#), [2-13](#)

SW11 (Ethernet mode) switch, [1-21](#), [2-13](#)

SW12 (Ethernet enable) switch, [1-18](#), [1-21](#),
[2-14](#)

SW13 (rotary/NAND) switch, [1-20](#), [2-14](#)

SW14 (UART1 setup) switch, [1-25](#), [2-15](#)

SW15 (IO) push button, [2-15](#)

SW16-17 (power down) push buttons, [2-15](#)

SW18 (reset) push button, [2-16](#)

SW19 (IO) push button, [2-15](#)

SW1 (boot mode select) switch, [1-18](#), [1-20](#),
[2-10](#)

SW20 (push button enable) switch, [1-24](#), [1-27](#),
[2-15](#), [2-16](#), [2-24](#)

SW21 (SPORT1 enable) switch, [2-18](#)

SW22 (battery) switch, [1-9](#), [2-18](#), [2-28](#)

SW2 (SPORT0 enable) switch, [1-22](#), [2-11](#)

SW3 (SPI flash CS) switch, [1-18](#)

SW5 (rotary encoder) switch, [2-11](#)

SW6 (flash enable) switch, [2-12](#)

SW7, [1-22](#)

SW7 (SPORT0 enable) switch, [1-22](#), [2-11](#)

SW9 (mic gain) switch, [1-23](#), [2-12](#)
switches, diagram of locations, [2-9](#)
synchronous dynamic random access memory,
 See SDRAM interface
system architecture, of this EZ-Board, [2-2](#)

T

technical support, [xviii](#)
thumbwheel control, [xiv](#)
TWI config switch (SW8), [1-22](#)

U

UART1 interface
 enable jumper (JP3), [1-20](#), [1-25](#), [1-35](#), [2-20](#)
 enable switch (SW14), [1-25](#), [2-15](#)
 loopback jumper (JP2), [2-20](#)
 UART1_RX signal, [2-20](#), [2-21](#), [2-24](#), [2-26](#)
 UART1_TX signal, [2-20](#), [2-21](#), [2-24](#), [2-26](#)
 voltage translator (U32) via JP3, [1-35](#)
UART interface
 connections, [1-24](#)
 expansion interface II connectors (P2, P4),
 [1-25](#)
 SD jumper (JP14), [1-35](#), [2-23](#)
U-Boot, universal boot loader, [1-19](#)
universal asynchronous receiver transmitter, *See*
 UART, UART1
USB host mode, [1-32](#)
USB monitor LED (LED4), [1-10](#)
USB on-the-go (OTG) interface
 connections, [1-23](#)
 connector (P8), [1-10](#), [1-24](#), [2-29](#), [2-34](#)
USB_VRSEL signal, [1-24](#), [1-27](#)

V

VDDEXT
 power jumper (P11), [1-36](#), [2-25](#)
 voltage, [1-25](#), [1-30](#)
VDDINT
 power jumper (P13), [1-36](#), [2-25](#)
 regulator (VR5), [1-35](#)
VDDMEM
 power jumper (P12), [1-36](#), [2-25](#)
 voltage, [1-30](#)
voltage planes, [1-29](#), [1-31](#), [2-16](#)
voltage translator (U4), [1-35](#)
VR7 enable jumper (JP9), [2-21](#)

W

WAKE signal, [1-28](#)
wall adaptor connector (P14), [1-10](#)
WALL_SENSE signal, [2-26](#)
watchdog timer, [1-26](#)

X-ON Electronics

Largest Supplier of Electrical and Electronic Components

Click to view similar products for [Development Boards & Kits - Other Processors](#) category:

Click to view products by [Analog Devices](#) manufacturer:

Other Similar products are found below :

[EVB-MEC1418MECC](#) [20-101-1252](#) [C29XPCIE-RDB](#) [CC-ACC-18M433](#) [MAX1464EVKIT](#) [RTE510Y470TGB00000R](#)
[RTK0EN0001D01001BZ](#) [MAXQ622-KIT#](#) [YR0K505231S000BE](#) [YR0K50571MS000BE](#) [YQB-R5F1057A-TB](#) [QB-R5F104PJ-TB](#) [CC-](#)
[ACC-ETHMX](#) [OV-7604-C7-EVALUATION-BOARD](#) [SK-AD02-D62Q1747TB](#) [SK-BS01-D62Q1577TB](#) [ST7MDT1-EMU2](#) [GROVE BASE](#)
[KIT FOR RASPBERRY PI](#) [CAB M-M\(40-17-RAINBOW\)](#) [CY8CKIT-143A](#) [EK-MPC5744P](#) [KITAURIXTC234TFTTOBO1](#) [ESP32-C3-](#)
[DEVKITC-02](#) [ENW89854AXKF](#) [ENWF9201AVEF](#) [QB-R5F104LE-TB](#) [LV18F V6 64-80-PIN TQFP MCU CARD EMPTY](#) [LV-24-33 V6](#)
[44-PIN TQFP MCU CARD EMPTY](#) [LV-24-33 V6 64-PIN TQFP MCU CARD EMPTY](#) [LV-24-33 V6 80-PIN TQFP 1 MCU CARD EMPTY](#)
[32X32 RGB LED MATRIX PANEL - 6MM PITCH](#) [3.3 - 5 VTRANSLATOR](#) [READY FOR XMEGA CASING \(WHITE\)](#) [RELAY4 BOARD](#)
[ETHERNET CONNECTOR](#) [RFID CARD 125KHZ - TAG](#) [RFID READER](#) [RFM12B-DEMO](#) [MAROON](#) [3G CLICK \(FOR EUROPE AND](#)
[AUSTRALIA\)](#) [MAX232](#) [MAX3232 BOARD](#) [ARTY S7-50](#) [THREE-AXIS ACCELEROMETER BOARD](#) [TINKERKIT HALL SENSOR](#)
[TOUCHPANEL](#) [TOUCHPANEL CONTROLLER](#) [MIKROBOARD FOR AVR WITH ATMEGA128](#) [MIKROBOARD FOR PSOC WITH](#)
[CY8C27643](#) [MIKROBUS CAPE](#)