

Blackfin Low Power Imaging Platform (BLIP)

A Revolutionary Advanced Occupancy Sensing Solution



Overview

Analog Devices has developed a low cost, low power embedded computer vision platform targeting a vast array of real-time sensing applications. The Blackfin® Low Power Imaging Platform (BLIP) leverages the latest entry within the industry-leading, low power Blackfin processor family as well as Analog Devices' optimized software library deliverables. This solution offers end equipment manufacturers an out of the box form factor development platform with multiple functional profiles covering intelligent motion sensing, people counting, vehicle detection, and face detection deployable in both indoor and outdoor use cases. The BLIP system includes an intuitive configuration GUI and enables real-time analysis of captured video, as well as video output/display through an on-board USB port, making it a highly valuable tool for product development. Additionally, the associated documentation package is well positioned to help customers accelerate their time to market.

Target Applications Include:

- Indoor/outdoor lighting control
- HVAC system control
- Access control systems
- Premise monitoring systems
- In-vehicle occupancy detection
- Logistics/retail analytics

BLIP Deployment Model

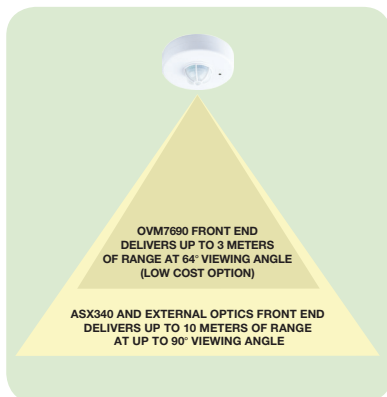

ADI and our partners can facilitate an application specific/custom BLIP implementation.

BLIP Appearance

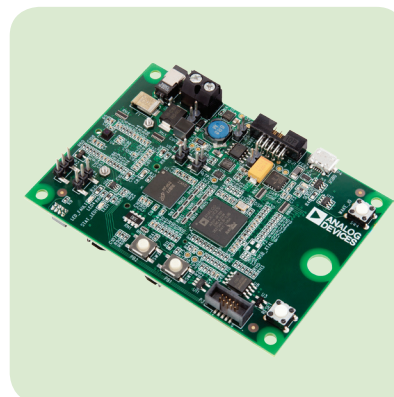

Top view.



Bottom view.

analog.com



BLIP Block Diagram

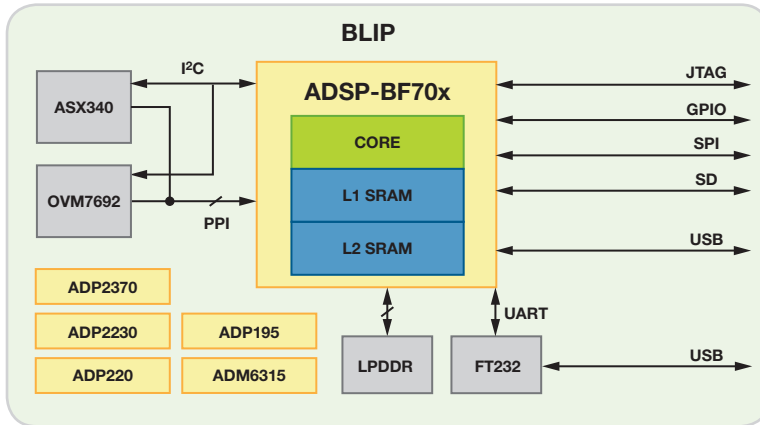

Video Occupancy Sensor Module

The Analog Devices BLIP hardware platform is delivered with a preloaded occupancy software module that has been optimized to detect the presence and behavior of humans or vehicles within indoor and outdoor environments. This advanced detection operation provides significantly improved performance compared to single pixel PIR sensor solutions targeting lighting control, climate control, and access control applications.

Blackfin Image Processing Toolbox

The Analog Devices video occupancy sensor software module and many other image analysis module deliverables are based upon the Blackfin image processing toolbox. This toolbox is a set of image processing primitives designed to enable faster development of complex image or video processing solutions for use on Blackfin processors. These primitive functions have been highly optimized to achieve the most efficient results possible on the Blackfin ADSP-BF5xx, ADSP-BF60x, and ADSP-BF70x families of devices. This toolbox library is MISRA-C compliant and also includes C reference code for the primitives and wrapper code layers for OpenCV like APIs.

Blackfin Low Power Imaging Platform Specifications and Details

Major Active System Components:

- Processor: ADSP-BF707BBCZ-4
- Imagers: OVM7692 (VGA SoC sensor with integrated lens), ASX-340 (VGA sensor)
- Memory: MT46H128M16LFB7 (256 MB)
- Flash: W25Q32 (32 MB)
- Power management: ADP2370, ADP2230, ADP220, ADP195, ADM6315
- Interface: FT232RQ

Specifications:

- Power consumption: <1 W
- Supply voltage: 3.2 V to 15 V
- Form factor: 2.5 inches × 3.5 inches

Board Support Package:

- Development tool chain: CrossCore® Embedded Studio™
- Application software: VOS 3.2.0 (indoor/outdoor)
- Documentation: user guide, PCB schematics

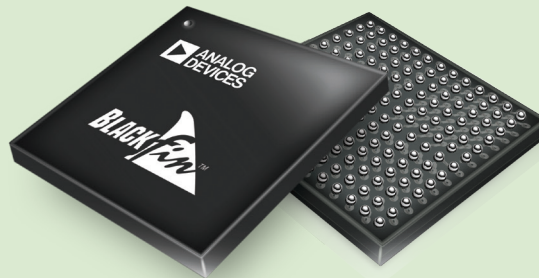

CrossCore®
Development Tools
by Analog Devices

**Analog Devices, Inc.
Worldwide Headquarters**
Analog Devices, Inc.
One Technology Way
P.O. Box 9106
Norwood, MA 02062-9106
U.S.A.
Tel: 781.329.4700
(800.262.5643,
U.S.A. only)
Fax: 781.461.3113

**Analog Devices, Inc.
Europe Headquarters**
Analog Devices, Inc.
Wilhelm-Wagenfeld-Str. 6
80807 Munich
Germany
Tel: 49.89.76903.0
Fax: 49.89.76903.157

**Analog Devices, Inc.
Japan Headquarters**
Analog Devices, KK
New Pier Takeshiba
South Tower Building
1-16-1 Kaigan, Minato-ku,
Tokyo, 105-6891
Japan
Tel: 813.5402.8200
Fax: 813.5402.1064

**Analog Devices, Inc.
Asia Pacific Headquarters**
Analog Devices
5F, Sandhill Plaza
2290 Zuchongzhi Road
Zhangjiang Hi-Tech Park
Pudong New District
Shanghai, China 201203
Tel: 86.21.2320.8000
Fax: 86.21.2320.8222

©2014 Analog Devices, Inc. All rights reserved.
Trademarks and registered trademarks are the
property of their respective owners.

Printed in the U.S.A. PH12140-1-11/14(A)

analog.com



X-ON Electronics

Largest Supplier of Electrical and Electronic Components

Click to view similar products for [Development Boards & Kits - Other Processors](#) category:

Click to view products by [Analog Devices](#) manufacturer:

Other Similar products are found below :

[EVB-MEC1418MECC](#) [20-101-1252](#) [C29XPCIE-RDB](#) [CC-ACC-18M433](#) [MAX1464EVKIT](#) [RTE510Y470TGB00000R](#)
[RTK0EN0001D01001BZ](#) [MAXQ622-KIT#](#) [YR0K505231S000BE](#) [YR0K50571MS000BE](#) [YQB-R5F1057A-TB](#) [QB-R5F104PJ-TB](#) [CC-](#)
[ACC-ETHMX](#) [OV-7604-C7-EVALUATION-BOARD](#) [SK-AD02-D62Q1747TB](#) [SK-BS01-D62Q1577TB](#) [ST7MDT1-EMU2](#) [GROVE BASE](#)
[KIT FOR RASPBERRY PI](#) [CAB M-M\(40-17-RAINBOW\)](#) [CY8CKIT-143A](#) [EK-MPC5744P](#) [KITAURIXTC234TFTTOBO1](#) [ESP32-C3-](#)
[DEVKITC-02](#) [ENW89854AXKF](#) [ENWF9201AVEF](#) [QB-R5F104LE-TB](#) [LV18F V6 64-80-PIN TQFP MCU CARD EMPTY](#) [LV-24-33 V6](#)
[44-PIN TQFP MCU CARD EMPTY](#) [LV-24-33 V6 64-PIN TQFP MCU CARD EMPTY](#) [LV-24-33 V6 80-PIN TQFP 1 MCU CARD EMPTY](#)
[32X32 RGB LED MATRIX PANEL - 6MM PITCH](#) [3.3 - 5 VTRANSLATOR](#) [READY FOR XMEGA CASING \(WHITE\)](#) [RELAY4 BOARD](#)
[ETHERNET CONNECTOR](#) [RFID CARD 125KHZ - TAG](#) [RFID READER](#) [RFM12B-DEMO](#) [MAROON](#) [3G CLICK \(FOR EUROPE AND](#)
[AUSTRALIA\)](#) [MAX232](#) [MAX3232 BOARD](#) [ARTY S7-50](#) [THREE-AXIS ACCELEROMETER BOARD](#) [TINKERKIT HALL SENSOR](#)
[TOUCHPANEL](#) [TOUCHPANEL CONTROLLER](#) [MIKROBOARD FOR AVR WITH ATMEGA128](#) [MIKROBOARD FOR PSOC WITH](#)
[CY8C27643](#) [MIKROBUS CAPE](#)