

BCD-to-Decimal Decoder

General Description

The CD4028B is a BCD-to-decimal or binary-to-octal decoder consisting of 4 inputs, decoding logic gates, and 10 output buffers. A BCD code applied to the 4 inputs, A, B, C, and D, results in a high level at the selected 1-of-10 decimal decoded outputs. Similarly, a 3-bit binary code applied to inputs A, B, and C is decoded in octal at outputs 0–7. A high level signal at the D input inhibits octal decoding and causes outputs 0–7 to go LOW.

All inputs are protected against static discharge damage by diode clamps to VDD and VSS.

Features

- Wide supply voltage range: 3.0V to 15V
- High noise immunity: 0.45 VDD (typ.)
- Low power TTL compatibility: fan out of 2 driving 74L or 1 driving 74LS
- Low power
- Glitch free outputs
- “Positive logic” on inputs and outputs

Applications

- Code conversion
- Address decoding
- Indicator-tube decode

ORDERING INFORMATION

DEVICE	Package Type	MARKING	Packing	Packing Qty
CD4028BEG	DIP16	CD4028BE	TUBE	1000pcs/box
CD4028BDRG	SOP16	CD4028B	REEL	2500pcs/reel

Connection Diagram

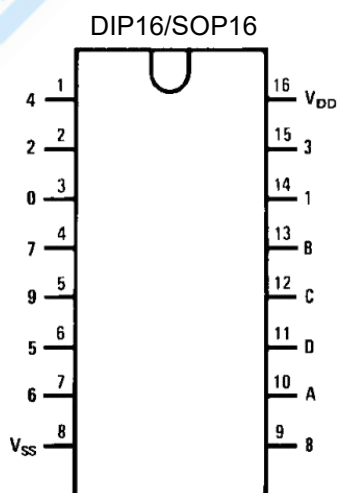

Truth Table

		D	C	B	A	0	1	2	3	4	5	6	7	8	9		
1 HIGH Level 0 LOW Level		0	0	0	0	1	0	0	0	0	0	0	0	0	0	0	BCD States
		0	0	0	1	0	1	0	0	0	0	0	0	0	0	0	
		0	0	1	0	0	0	1	0	0	0	0	0	0	0	0	
		0	0	1	1	0	0	0	0	1	0	0	0	0	0	0	
		0	1	0	0	0	0	0	0	1	0	0	0	0	0	0	
		0	1	0	1	0	0	0	0	0	1	0	0	0	0	0	
		0	1	1	0	0	0	0	0	0	0	1	0	0	0	0	
		0	1	1	1	0	0	0	0	0	0	0	1	0	0	0	
		1	0	0	0	0	0	0	0	0	0	0	0	0	1	0	
		1	0	0	1	0	0	0	0	0	0	0	0	0	0	1	
		1	0	1	0	0	0	0	0	0	0	0	0	1	0	Extraordinary States	
		1	0	1	1	0	0	0	0	0	0	0	0	0	1		
		1	1	0	0	0	0	0	0	0	0	0	0	1	0		
		1	1	0	1	0	0	0	0	0	0	0	0	0	1		
		1	1	1	0	0	0	0	0	0	0	0	0	1	0		
		1	1	1	1	0	0	0	0	0	0	0	0	0	1		

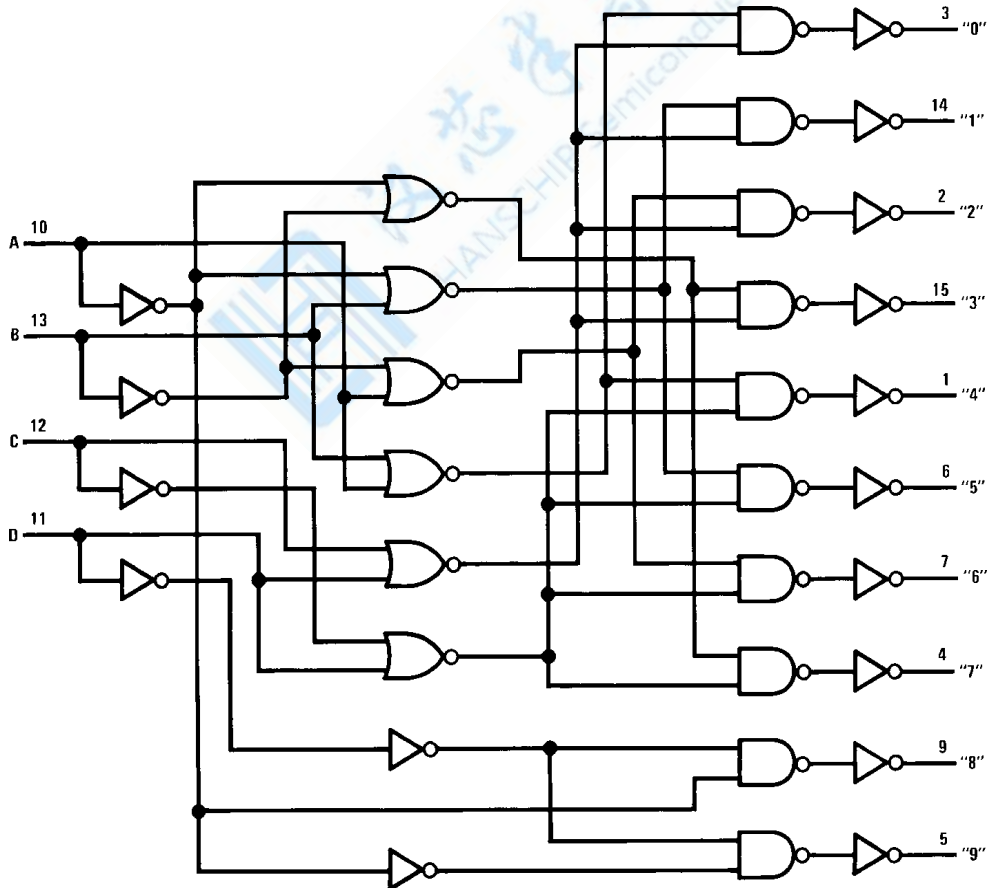
Logic Diagram

ABSOLUTE MAXIMUM RATINGS

CONDITION		MIN	MAX
Supply Voltage (V _{DD})		-0.5V	+18V
Input Voltage (V _{IN})		-0.5V	V _{DD} +0.5V
Storage Temperature Range (T _S)		-65°C	+150°C
Power Dissipation (P _D)	Dual-In-Line	700 mW	
	Small Outline	500 mW	
(Soldering, 10 seconds)		260°C	

RECOMMENDED OPERATING CONDITIONS

CHARACTERISTIC	Min.	Max.	Units
Supply Voltage (V _{DD})	3	15	V
Input Voltage (V _{IN})	0	V _{DD}	V
Operating Temperature Range (T _A)	-40	+85	°C

Note 1: “Absolute Maximum Ratings” are those values beyond which the safety of the device cannot be guaranteed, they are not meant to imply that the devices should be operated at these limits. The table of “Recommended Operating Conditions” and “Electrical Characteristics” provides conditions for actual device operation.

Note 2: V_{SS} = 0V unless otherwise specified.

DC Electrical Characteristics (Note 2)

Symbol	Parameter	Conditions	40°C		25°C		85°C		Units	
			Min	Max	Min	Typ	Max	Min		Max
I _{DD}	Quiescent Device Current	V _{DD} = 5V, V _{IN} = V _{DD} or V _{SS}		20		0.01	20		150	μA
		V _{DD} = 10V, V _{IN} = V _{DD} or V _{SS}		40		0.01	40		300	μA
		V _{DD} = 15V, V _{IN} = V _{DD} or V _{SS}		80		0.02	80		600	μA
V _{OL}	LOW Level Output Voltage	I _O < 1 μA, V _{IL} = 0V, V _{IH} = V _{DD}		0.05		0	0.05		0.05	V
		V _{DD} = 5V		0.05		0	0.05		0.05	V
		V _{DD} = 10V		0.05		0	0.05		0.05	V
V _{OH}	HIGH Level Output Voltage	I _O < 1 μA, V _{IL} = 0V, V _{IH} = V _{DD}	4.95		4.95	5		4.95		V
		V _{DD} = 5V	9.95		9.95	10		9.95		V
		V _{DD} = 10V	14.95		14.95	15		14.95		V
V _{IL}	LOW Level Input Voltage	I _O < 1 μA		1.5		2.25	1.5		1.5	V
		V _{DD} = 5V, V _O = 0.5V or 4.5V		3.0		4.5	3.0		3.0	V
		V _{DD} = 10V, V _O = 1V or 9V		4.0		6.75	4.0		4.0	V
V _{IH}	HIGH Level Input Voltage	I _O < 1 μA	3.5		3.5			3.5		V
		V _{DD} = 5V, V _O = 0.5V or 4.5V	7.0		7.0			7.0		V
		V _{DD} = 10V, V _O = 1V or 9V	11.0		11.0			11.0		V
I _{OL}	LOW Level Output Current (Note 3)	V _{IH} = V _{DD} , V _{IL} = 0V	0.52		0.44	0.88		0.36		mA
		V _{DD} = 5V, V _O = 0.4V	1.3		1.1	2.2		0.9		mA
		V _{DD} = 10V, V _O = 0.5V	3.6		3.0	6.0		2.4		mA
I _{OH}	HIGH Level Output Current (Note 3)	V _{IH} = V _{DD} , V _{IL} = 0V	-0.2		-0.16	-0.32		-0.12		mA
		V _{DD} = 5V, V _O = 4.6V	-0.5		-0.4	-0.8		-0.3		mA
		V _{DD} = 10V, V _O = 9.5V	-1.4		-1.2	-3.5		-1.0		mA
I _{IN}	Input Current	V _{DD} = 5V, V _{IN} = 0V		-0.3			-0.3		-1.0	μA
		V _{DD} = 15V, V _{IN} = 15V		-0.3			-0.3		-1.0	μA

Note 3: I_{OL} and I_{OH} are tested one output at a time.

AC Electrical Characteristics (Note 4)

TA = 25°C, CL = 50 pF, RL = 200k, Input tr = tf = 20 ns, unless otherwise specified

Symbol	Parameter	Conditions	Min	Typ	Max	Units
tPHL or tPLH	Propagation Delay Time	VCC = 5V		240	480	ns
		VCC = 10V		100	200	ns
		VCC = 15V		70	140	ns
tTHL or tTLH	Transition Time	VCC = 5V		175	350	ns
		VCC = 10V		75	150	ns
		VCC = 15V		60	110	ns
CIN	Input Capacitance	Any Input		5	7.5	pF

Note 4: AC Parameters are guaranteed by DC correlated testing.

Switching Time Waveforms

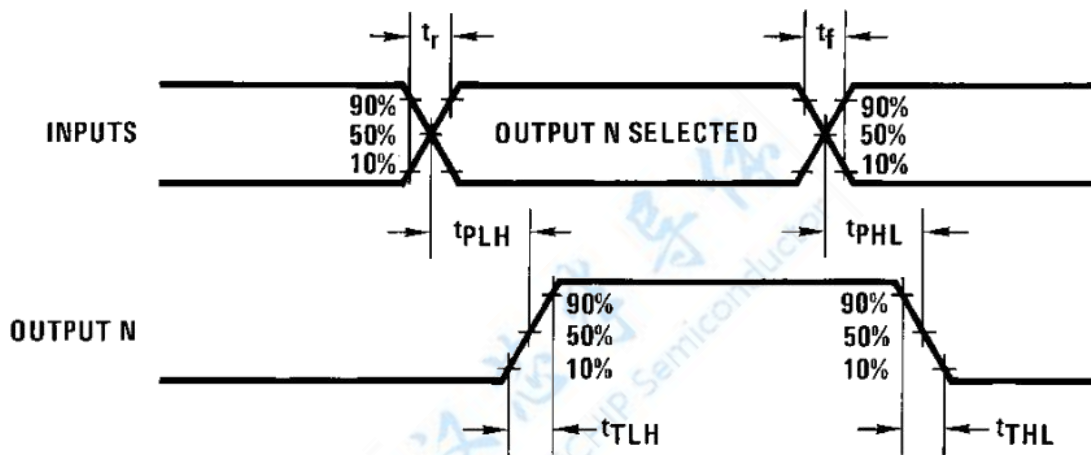

Physical Dimensions

SOP16

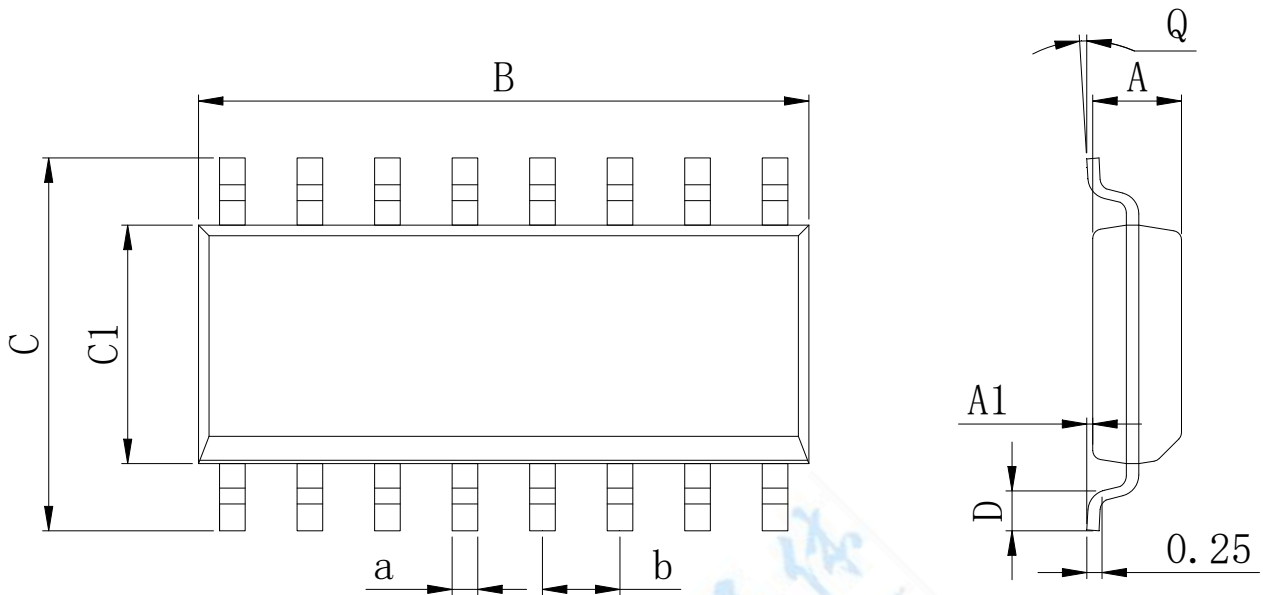
Dimensions In Millimeters(SOP16)

Symbol:	A	A1	B	C	C1	D	Q	a	b
Min:	1.35	0.05	9.80	5.80	3.80	0.40	0°	0.35	1.27 BSC
Max:	1.55	0.20	10.0	6.20	4.00	0.80	8°	0.45	

DIP16

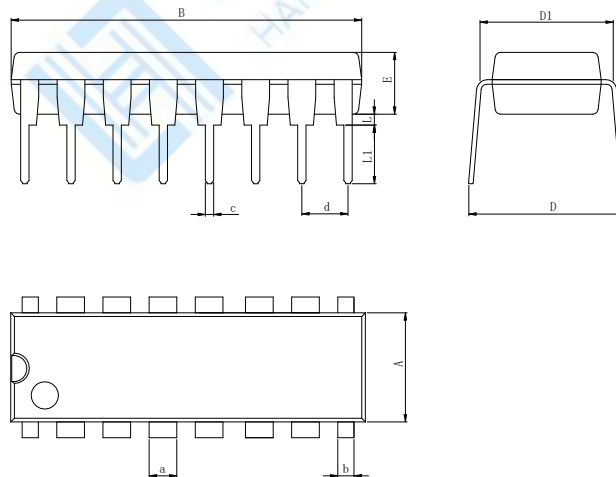
Dimensions In Millimeters(DIP16)

Symbol:	A	B	D	D1	E	L	L1	a	b	c	d
Min:	6.10	18.94	8.40	7.42	3.10	0.50	300	1.50	0.85	0.40	2.54 BSC
Max:	6.68	19.56	9.00	7.82	3.55	0.70	3.60	1.55	0.90	0.50	

IMPORTANT STATEMENT:

Shenzhen Hanschip semiconductor co.,ltd. reserves the right to change the products and services provided without notice. Customers should obtain the latest relevant information before ordering, and verify the timeliness and accuracy of this information.

Customers are responsible for complying with safety standards and taking safety measures when using our products for system design and machine manufacturing to avoid potential risks that may result in personal injury or property damage.

Our products are not licensed for applications in life support, military, aerospace, etc., so we do not bear the consequences of the application of these products in these fields.

Our documentation is only permitted to be copied without any tampering with the content, so we do not accept any responsibility or liability for the altered documents.

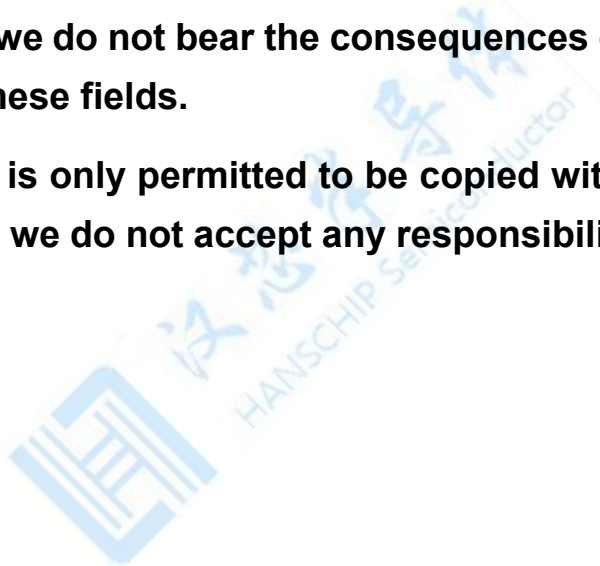

X-ON Electronics

Largest Supplier of Electrical and Electronic Components

Click to view similar products for [Counter ICs](#) category:

Click to view products by [Analog Devices](#) manufacturer:

Other Similar products are found below :

[CD4018BE](#) [CD4033BE](#) [CD4060BE](#) [CD4040BE](#) [NLV14040BDR2G](#) [RFDIP1607ALM9T21](#) [RFDIP1606L708D1T](#) [RFTIP2510T12A8Q1C](#)
[74HC161DT](#) [CD4028BM/TR](#) [CD4060DM/TR](#) [CD4022BE](#) [CD4060DMT/TR](#) [CD4020BE](#) [CD4060BMT/TR](#) [74HC192M/TR](#)
[CD4020BMT/TR](#) [CD4017CMT/TR](#) [74HC193M/TR](#) [CD4017CM/TR](#) [AiP74HC193SA16.TB](#) [CD4518BM/TR](#) [CD4060TA16.TB](#) [CD4060DE](#)
[CD4017CN](#) [CD4017BMT/TR](#) [U74HC4060G-S16-R](#) [CD4017SA.TB](#) [XD74LS160](#) [CD4017BM-MS](#) [CD4022BM/TR](#) [CD4022BMT/TR](#)
[CD4028BDRG](#) [CD4060BDRG](#) [CD4017DA.TB](#) [CD4520BDRG](#) [CD4520BM\(LX\)](#) [CD4518BM\(LX\)](#) [SN74HC393DR\(LX\)](#) [SN74HC393N\(LX\)](#)
[CD4060BM\(LX\)](#) [CD4060BE\(LX\)](#) [CD4518BE\(LX\)](#) [CD4520BE\(LX\)](#) [74VHC393FT\(BJ\)](#) [74VHC161FT\(BJ\)](#) [74VHC163FT\(BJ\)](#)
[74HC4040D.653](#) [74HC4060D.653](#) [74HCT4040D.653](#)