

QUICK START GUIDE FOR DEMONSTRATION CIRCUIT 1008

600MA SYNCHRONOUS STEP-DOWN REGULATOR WITH PLL, SOFT-START AND SPREAD SPECTRUM

LTC3543

DESCRIPTION

Demonstration circuit 1008 is a step-down converter, using the LTC3543 monolithic synchronous buck regulator. The DC1008 has an input voltage range of 2.5V to 5.5V, and is capable of delivering up to 600 mA of output current in a small 2mm x 3mm DFN package. The output voltage of the DC1008 can be set as low as 0.6V, the reference voltage of the LTC3543. At low load currents, the DC1008 can operate in either applications requiring high efficiency, due to the capability of the LTC3543 to operate in Burst Mode, or in noise sensitive applications, because the LTC3543 can also operate in pulse-skipping mode. Also in noise sensitive applications, since the LTC3543 has Spread Spectrum capability, the DC1008 can provide low noise on the input, as well as a lower noise regulated output. Of course, in

continuous mode, or large load current applications, the DC1008 is a high efficiency circuit - over 90% in some cases. The DC1008A consumes only 40 μ A during sleep mode operation, and during shutdown, it consumes less than 1 μ A. Because of the high switching frequency of the LTC3543 - 2.25 MHz - the DC1008 uses low profile surface mount components. These features, plus the LTC3543 coming in a tiny 6-Lead DFN package, make the DC1008A an ideal circuit for use in battery-powered, hand-held applications.

Design files for this circuit board are available. Call the LTC factory.

 , LTC and LT are registered trademarks of Linear Technology Corporation.

Table 1. Performance Summary ($T_A = 25^\circ\text{C}$)

PARAMETER	CONDITIONS	VALUE
Minimum Input Voltage		2.5V
Maximum Input Voltage		5.5V
Run/Shutdown	GND = Shutdown	
	$V_{IN} = \text{Run}$	
Output Voltage V_{OUT}	$V_{IN} = 2.5\text{V to } 5.5\text{V}$, $I_{OUT} = 0\text{A to } 600\text{ mA}$	$1.8\text{V} \pm 4\%$ (1.728V – 1.872V)
Typical Output Ripple V_{OUT}	$V_{IN} = 5\text{V}$, $I_{OUT} = 600\text{ mA}$ (20 MHz BW)	$< 20\text{mV}_{P-P}$
Output Regulation	Line	$\pm 1\%$ (1.782V – 1.818V)
	Load	$\pm 1\%$ (1.782V – 1.818V)
Nominal Switching Frequency		2.25 MHz
Operation Modes	Burst Mode - $V_{IN} = 3.3\text{V}$, $V_{OUT} = 1.8\text{V}$	$\sim 75\text{ mA} \pm 10\text{ mA}$
	Pulse-Skip - $V_{IN} = 3.3\text{V}$, $V_{OUT} = 1.8\text{V}$	$\sim 75\text{ mA} \pm 10\text{ mA}$
	Spread Spectrum	See Photo

QUICK START GUIDE FOR DEMONSTRATION CIRCUIT 1008

600MA SYNCHRONOUS STEP-DOWN REGULATOR WITH PLL, SOFT-START AND SPREAD SPECTRUM

QUICK START PROCEDURE

Demonstration Circuit 1008 is easy to set up to evaluate the performance of the LTC3543. For proper measurement equipment configuration, set up the circuit according to the diagram in **Figure 2**. Before proceeding to test, insert shunts into the OFF position of header JP1, which connects the RUN pin to ground (GND), and thus, shuts down the circuit, and the pulse-skip position (PS) of header JP2.

When measuring the input or output ripple voltage, care must be taken to avoid a long ground lead on the oscilloscope probe. Measure the input or output ripple voltage by touching the probe tip directly across the Vin or Vout and GND terminals. See **Figure 1** for proper scope probe measurement technique.

With the DC1008 set up according to the proper equipment measurement configuration in **Figure 2**, apply 3.3V at Vin (Do not hot-plug Vin or increase Vin over the rated maximum supply voltage of 5.5V, or the part may be damaged.). Measure Vout; it should read 0V. If desired, one can measure the shutdown supply current at this point. The supply current will be approximately 1 μ A, or less, in shutdown.

Turn on the circuit by inserting the shunt in header JP1 into the ON position. The output voltage should be regulating. Measure Vout - it should measure 1.8V +/- 2% (1.764V to 1.836V).

Vary the input voltage from 2.5V to 5.5V and adjust the load current from 0 to 600 mA. Vout should read between 1.8V +/- 4% (1.728V to 1.872V).

Measure the output ripple voltage at any output current level; it should measure less than 20 mVAC.

Observe the voltage waveform at the switch node. Verify the switching frequency is between 1.8 MHz and 2.7 MHz ($T = 0.555 \mu$ s and 0.37μ s), and that the switch node waveform is rectangular in shape in continuous mode at $I_{out} > 75$ mA. The circuit (and IC) should be in pulse-skip mode at $I_{out} < 75$ mA. Move the shunt in header JP2 to Burst Mode (BM): the circuit (and IC) should be in Burst Mode at $I_{out} < 75$ mA. Move the shunt in header JP2 to spread spectrum mode (SS): the circuit (and IC) should be in spread spectrum operation at any and all output current levels (see scope photo).

When finished, turn off the circuit by inserting the shunt in header JP1 into the OFF position.

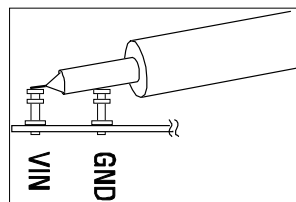

Figure 1. Measuring Input or Output Ripple Voltage

QUICK START GUIDE FOR DEMONSTRATION CIRCUIT 1008

600MA SYNCHRONOUS STEP-DOWN REGULATOR WITH PLL, SOFT-START AND SPREAD SPECTRUM

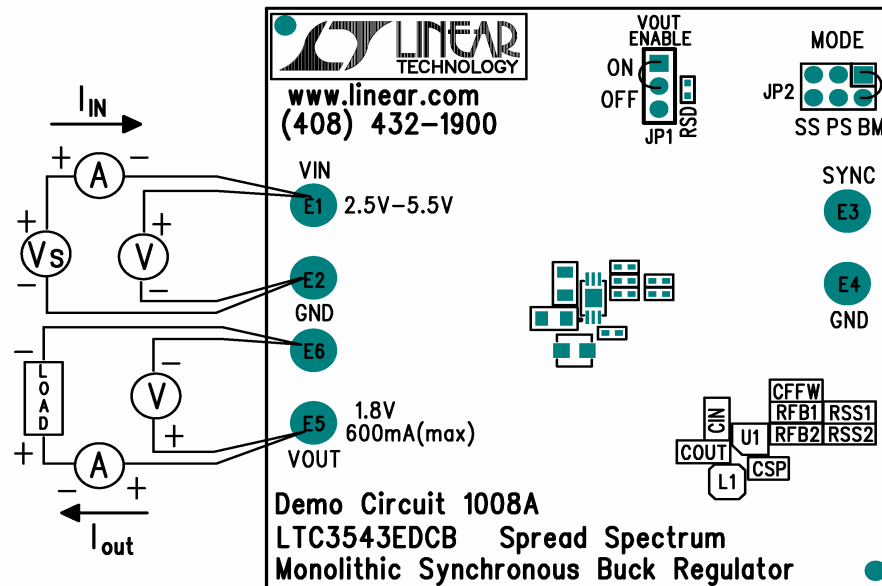

Figure 2. Proper Equipment Measurement Set-Up

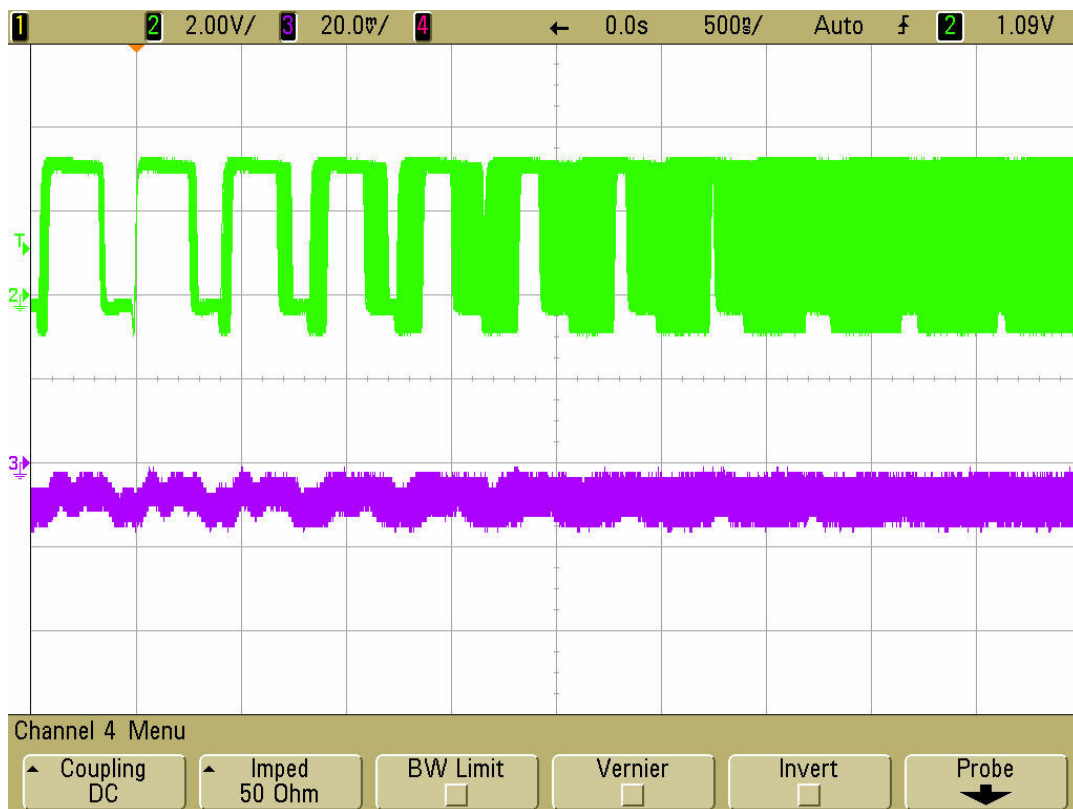
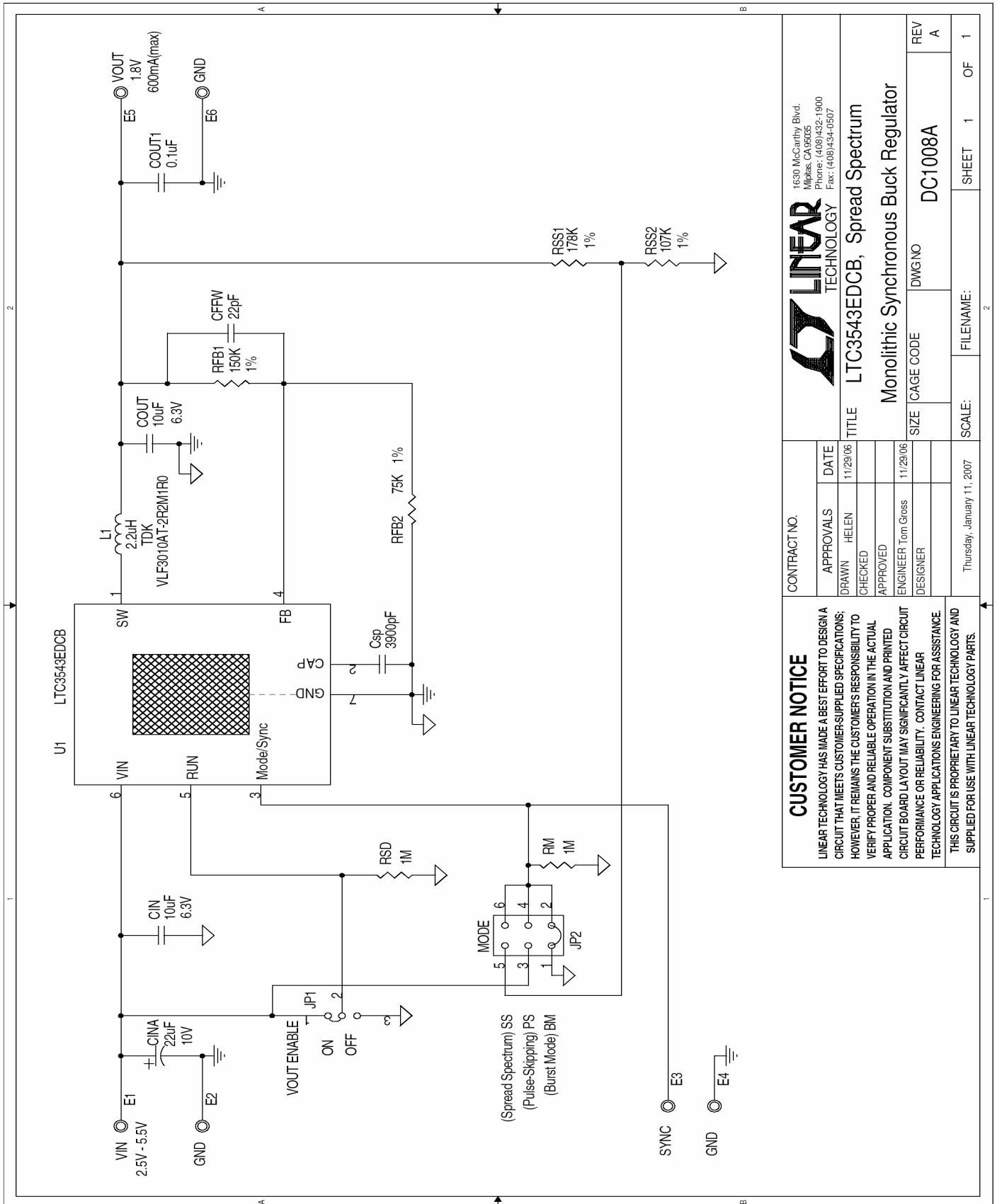

Figure 3. Spread Spectrum Operation: Vin - 3.3V, Vout - 1.8V, Iout - 600mA

QUICK START GUIDE FOR DEMONSTRATION CIRCUIT 1008

600mA SYNCHRONOUS STEP-DOWN REGULATOR

WITH PLL, SOFT-START AND SPREAD SPECTRUM



CUSTOMER NOTICE

LINEAR TECHNOLOGY HAS MADE A BEST EFFORT TO DESIGN A CIRCUIT THAT MEETS CUSTOMER-SUPPLIED SPECIFICATIONS; HOWEVER, IT REMAINS THE CUSTOMER'S RESPONSIBILITY TO VERIFY PROPER AND RELIABLE OPERATION IN THE ACTUAL APPLICATION. COMPONENT SUBSTITUTION AND PRINTED CIRCUIT BOARD LAYOUT MAY SIGNIFICANTLY AFFECT CIRCUIT PERFORMANCE OR RELIABILITY. CONTACT LINEAR TECHNOLOGY APPLICATIONS ENGINEERING FOR ASSISTANCE. THIS CIRCUIT IS PROPRIETARY TO LINEAR TECHNOLOGY AND SUPPLIED FOR USE WITH LINEAR TECHNOLOGY PARTS.

CONTRACT NO.

APPROVALS	DATE
DRAWN HELEN	11/29/06
CHECKED	
APPROVED	
ENGINEER Tom Gross	11/29/06
DESIGNER	



1630 McCarthy Blvd.
Milpitas, CA 95035
Phone: (408)432-1900
Fax: (408)434-0507

TITLE LTC3543EDCB, Spread Spectrum
Monolithic Synchronous Buck Regulator

SIZE	CAGE CODE	DWG NO	REV
		DC1008A	A

Thursday, January 11, 2007

SCALE:

FILENAME:

SHEET 1 OF 1

X-ON Electronics

Largest Supplier of Electrical and Electronic Components

Click to view similar products for [Power Management IC Development Tools](#) category:

Click to view products by [Analog Devices](#) manufacturer:

Other Similar products are found below :

[EVAL-ADM1168LQEBZ](#) [EVB-EP5348UI](#) [MIC23451-AAAYFL EV](#) [MIC5281YMME EV](#) [DA9063-EVAL](#) [ADP122-3.3-EVALZ](#) [ADP130-0.8-EVALZ](#) [ADP130-1.2-EVALZ](#) [ADP130-1.5-EVALZ](#) [ADP130-1.8-EVALZ](#) [ADP1714-3.3-EVALZ](#) [ADP1716-2.5-EVALZ](#) [ADP1740-1.5-EVALZ](#) [ADP1752-1.5-EVALZ](#) [ADP1828LC-EVALZ](#) [ADP1870-0.3-EVALZ](#) [ADP1871-0.6-EVALZ](#) [ADP1873-0.6-EVALZ](#) [ADP1874-0.3-EVALZ](#) [ADP1882-1.0-EVALZ](#) [ADP199CB-EVALZ](#) [ADP2102-1.25-EVALZ](#) [ADP2102-1.875EVALZ](#) [ADP2102-1.8-EVALZ](#) [ADP2102-2-EVALZ](#) [ADP2102-3-EVALZ](#) [ADP2102-4-EVALZ](#) [ADP2106-1.8-EVALZ](#) [ADP2147CB-110EVALZ](#) [AS3606-DB](#) [BQ24010EVM](#) [BQ24075TEVM](#) [BQ24155EVM](#) [BQ24157EVM-697](#) [BQ24160EVM-742](#) [BQ24296MEVM-655](#) [BQ25010EVM](#) [BQ3055EVM](#) [NCV891330PD50GEVB](#) [ISLUSBI2CKIT1Z](#) [LM2744EVAL](#) [LM2854EVAL](#) [LM3658SD-AEV/NOPB](#) [LM3658SDEV/NOPB](#) [LM3691TL-1.8EV/NOPB](#) [LM4510SDEV/NOPB](#) [LM5033SD-EVAL](#) [LP38512TS-1.8EV](#) [EVAL-ADM1186-1MBZ](#) [EVAL-ADM1186-2MBZ](#)